



*John*  
**BEAN**  
*Company*

**Model:** 600,700,EEBR300A  
Series Lathe

# Installation Instructions

## Lathe Cover

An optional lathe enclosure part number 91489 has been released for use with all brake lathes. The following is the correct procedure for installation.

**Safety Warning: Lathe and accessories are very heavy. The use of a hoist or other lifting device is strongly recommended.**

### INSTALLATION OVERVIEW:

1. Remove the lathe and rubber mat from bench, and discard old bolts.
2. Place the cover onto the bench and line up the mounting holes.
3. Place the rubber mat in its respective location.
4. Install the lathe onto the rubber mat while lining up the mounting holes.
5. Insert the supplied bolts through the mounting holes from the bottom.  
**Note: The 2 ¼ inch bolt is to be placed into the left front mounting hole with the threads facing upwards. The other 2 ½ inch bolts will be installed with the threads facing down.**
6. Insert the rubber hose and clamp onto the under side of the chip drain sleeve.
7. Tighten clamp.

**Caution:** This cover contains a small 17watt fan pulling .2 amps. The power cord for this fan must contain an earth ground.

**Note:** When installing this cover a foot extension must be installed on all 91218 benches. These benches have a 20-inch wide base, all other benches will not require the extension. This extension will bolt on the left side of the lathe bench; the hardware will come with the cover for mounting this extension.

### Service Parts

Description	Part Number	Qty
Top Cover (Fiberglass)	00092293000	1
Bottom Cover (Fiberglass)	00092294000	1
Guard – Cooling Fan	00092295000	1
Switch – On/Off 115volt	00092296000	1
Strain Relief	00092297000	1
Filter-Automotive(fram-ca192)	00092298000	1
Tube, Plastic Flexible	00092299000	1
Gas Spring	00092300000	2
Fan – Cooling	00040325000	1
Fuse holder	00064087000	1
Fuse 1.0 amp	00074105000	1
Leg Bracket	00091491000	1
Cable – Power SJO 18/3	00092301000	1

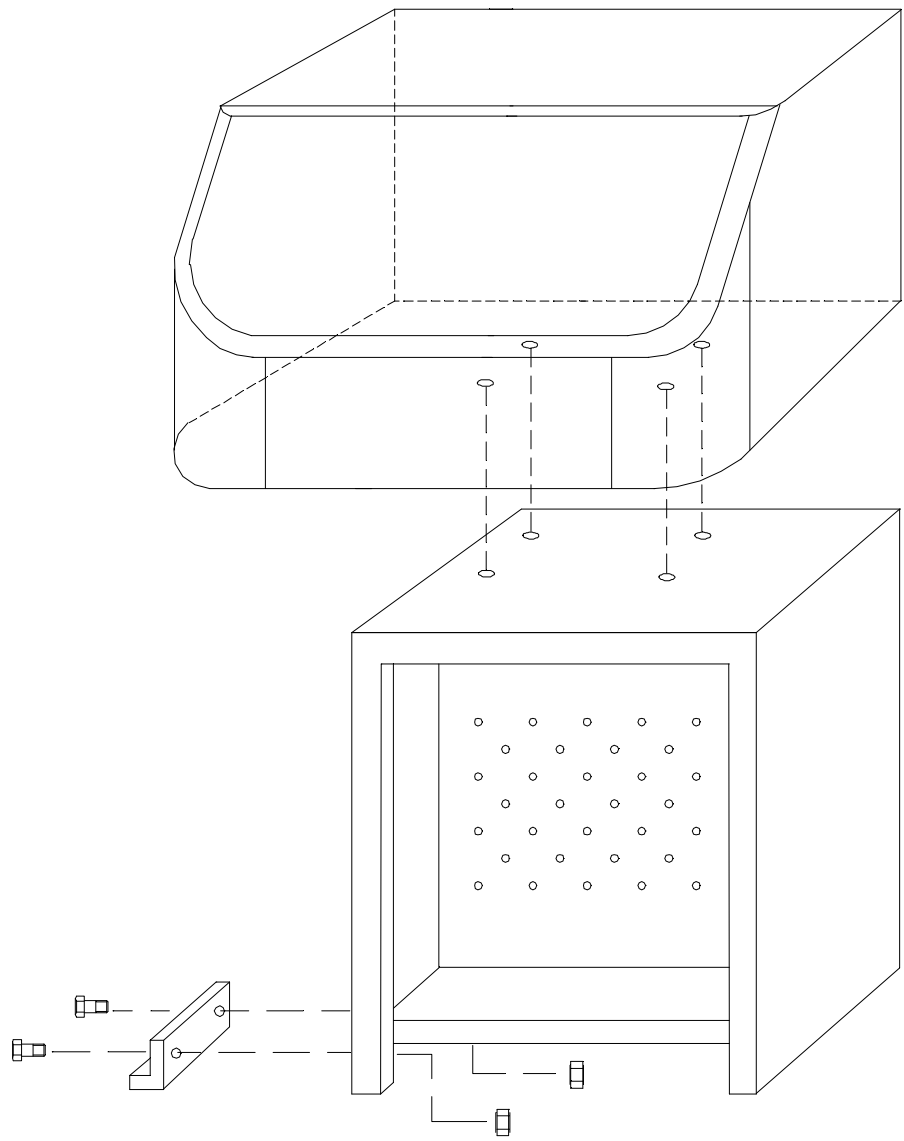

AX - 17221