



Model: EEEA116A
TEXAS, Service Inspection
System Analyzer Setup

Page: 1 of 6

Installation Instructions

**INSTALLATION MUST BE PERFORMED
BY
QUALIFIED PERSONNEL ONLY**

INSTALLATION OVERVIEW: _____

The John Bean Texas Analyzer is shipped as a fully assembled analyzer, with the exception of the Keyboard, Monitor, Printer and accessories. The following instructions, along with the Monitor Base Kit Instructions (EAK0185L00A), will provide you with the steps necessary to completely setup the analyzer.

PARTS & ACCESSORIES LIST: _____

PART NUMBER	DESCRIPTION	QTY
0131-0031-01	Gas Bottle Regulator	2
0271-0062-01	Low Scale, Calibration Gas	Local
0271-0066-01	Mid Scale, Calibration Gas	Local
0301-0944-01	Filter Element, 75 Micron	4
0301-0945-01	Filter Element, 8 Micron	4
0507-0025-01	Anti-Dilution Exhaust Probe	1
0528-0032-01	Printer, Okidata 390 Turbo	1
0528-1011-02	Printer Paper	1
0528-1094-01	Ribbon, Printer	2
0552-0072-01	1.44 Megabyte Floppy Unformatted	1
0552-0104-01	DOS 6.22 Package	1
0552-1086-01	Keyboard Cover Protector	1
0610-1511-04	Screw, Sheet Metal #8 X ¼	4
0692-1834-01	Quality Control Questionnaire, SEL 1043C	1
0692-2442-01	Operators Manual (Generic)	1
0692-2445-01	Installation Instruction	1
0692-2462-01	Vehicle Diagnostic Manual	1
0787-0035	Cap	2
1-4281	Filter, In-Line	2
1-7726	Screw, 10x32 x ½" HWHTT	6
2161-0023	Lead Hanger	6
3-606	Monitor, 15" SVGA Color	1
3988-0230-01	Hose Assembly, Exhaust 3/16	1
3988-0231-01	Hose Assembly, Exhaust Dual 3/16	1
5878-0016	Cable Tie, 14.5"	1
6004-0262-05	Cable Assembly, Trigger Pickup	1
6004-0462	Test Lead, Volt / Ohm	1

PART NUMBER	DESCRIPTION	QTY
6004-0566-01	Cable Assembly, Tachometer Lead	1
6004-0614-01	Antenna Cable	1
6005-0181-01	Adapter Assembly, Nissan Pulsar/Quad 4	1
6005-0184-01	Adapter, Rpm, BMW	1
6005-0184-02	Adapter, Rpm, Acura	1
7009-1869	Probe Exhaust Assembly.	2
7009-1929	Trigger Pickup Assembly.	1
7009-2037-01	Antenna, RPM (Figure 8)	1
7009-2223-01	Adapter, RPM, Nissan 300ZX Turbo	1
7049-0004-01	O2 Sensor	1
EAA0136C01A	Hose, Low Scale Gas ID Tag	1
EAA0136C02A	Hose, Mid Scale Gas ID Tag	1
EAA0190L10A	Hanger, Lead	4
EAK0185L00A	Monitor Base Kit	1
EAL0234C00A	Keyboard Label	1
EAL0264C00A	Label, Service Call	1
EASC071C82A	Bar Code Scanner Storage Bracket	1
EASC071C83A	Bar Code Scanner Mounting Bracket	1
EAW0096C00A	Monitor AC Power Cable	1
ZEEEE116A	Operator's Manual (Specifically For Texas)	1

REQUIRED TOOLS: _____

- MID GAS BOTTLE (0271-0066-01) LOW GAS BOTTLE (0271-0062-01)
- COMPLETE TOOL KIT ANTI-STATIC KIT
- SERVICE KEYS (from Technical Support (215, and 225))

INSTALLATION INSTRUCTIONS: _____



NOTE: *If the SIS was soft shipped (shipped without a carton) skip steps 1 through 4.*

1. Cut the Straps, and remove the top of the carton, top packing, and carton sides.
2. Slide the SIS and carton base off of the pallet, and split the corners of the base carton.
3. Lean the SIS so that one half of the foam base can be removed.
4. Lean the SIS so the other half of the foam base can be removed.
5. Remove all shipping tape from the SIS Cabinet.
6. Check for proper AC and GROUND connections at the outlet. This can be accomplished by using an AC outlet polarity checker, that can be obtained at a local hardware store.
7. Place the Operate/Standby switch into the operate position.
8. Verify that the parts and accessories listed are all present with the machine.
9. Following the instructions in the Monitor Base Kit (EAK0185L00A), attach the monitor to the SIS.
10. Remove and discard the Monitor AC Power Cable that was shipped with the monitor.
11. Connect the Monitor AC Power Cable (EAW0096C00A) to the back of the monitor, and to the AC port on the rear panel of the analyzer labeled "Video Power".

12. Connect the Data cable coming from the rear of the monitor to the port on the rear of the analyzer, below the monitor, labeled "Video".

NOTE: *The Blue and Red connectors, for the Speakers in the monitor, do not get connected. They can be tie wrapped to the Video Data Cable.*

13. Remove the bubble wrap from the keyboard, and ensure that it is plugged into the keyboard extension under the monitor.

NOTE: *The following step may be completed at the factory.*

14. Attach the Keyboard Label (EAL0234C00A) to the top of the keyboard (0552-0117-01).
15. Attach the Keyboard Cover (0552-1086-01) to the top of the keyboard.
16. In order to mount Velcro turn the keyboard upside down. Peel the backing off the hook side Velcro (0424-0804-02) and attach to keyboard. Attach soft side (Loop) Velcro (0424-0804-01) to Velcro Hook. Remove backing, exposing adhesive and place keyboard in its proper position and press firmly.
17. Place a package of printer paper (0528-1011-02), in the rectangular spot, under the slide out printer shelf.
18. Remove the Printer (0528-0032-01) from its carton. Remove all tape from the printer and remove the carriage cover to gain access to the print head. Referring to Figure 1, ensure that the printer ribbon cartridge is installed properly and remove the plastic stop that secures the print head.

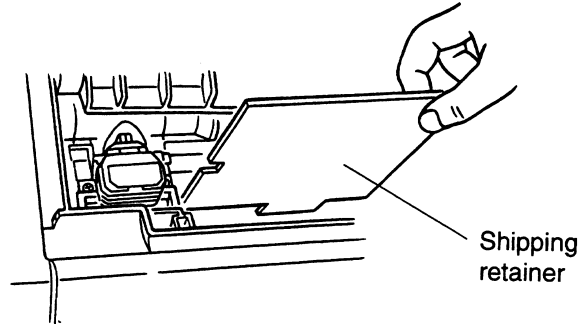

Figure 1, Shipping Retainer Removal

19. Load the printer paper, installed in step 16 into the Printer.
20. Referring to Figure 2, remove the Ribbon Cartridge Inspection Cover, by gently pulling up on the middle of this cover until it pops off.

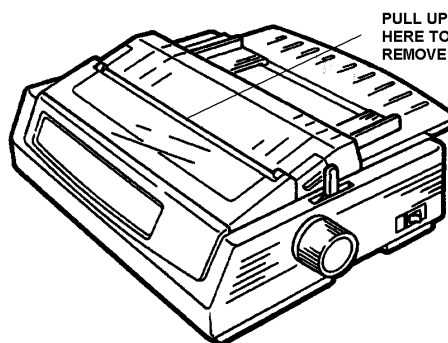

Figure 2, Ribbon Cartridge Inspection Cover Removal

21. Place the printer on the printer shelf, in the opening below the keyboard. Attach the power cable and data cable, already located in the analyzer, to their respective ports on the back of the printer.
22. Attach a wire tie to the rear of the printer, just behind the power connector of the printer to secure both the Printer Power and Data Cables. This will stop the cables from getting in the way of the paper.

23. Using the six 10-32x1/2" screws (1-7726), install the six hangers (2161-0023) into the slots on the rear corners of the Analyzer. Three slots are located on each corner of the tester's stand.
 24. Attach the four (4) Lead Hangers (EAA0190L00A) to the Unit Handles.
- NOTE: *The Bar Code Reader Bracket can be mounted on either side of the Analyzer.***
25. Mount the Bar Code Scanner Mounting Bracket (EASC071C83A) to the underside of the Computer Cabinet Sheet Metal Assembly, using two of the #8 X ¼ Sheet Metal Screws (0610-1511-04).
 26. Mount the Bar Code Scanner Storage Bracket (EASC071C82A) to the Mounting Bracket just installed, using two of the #8 X ¼ Sheet Metal Screws (0610-1511-04).
 27. Place the following items in the storage area:
 - (4) 75 Micron Filter Elements (0301-0944-01)
 - (4) 8 Micron Filter Elements (0301-0945-01)
 - (1) Printer Ribbon (0528-1094-01)
 - (1) DOS 6.22 Package (0552-0104-01)
 - (2) Exhaust Probe Leak Check Caps (0787-0035)
 - (1) Anti-Dilution Exhaust Probe Cap (0507-0025-01)
 - (1) BMW RPM Adapter (6005-0184-01)
 - (1) Acura RPM Adapter (6005-0184-02)
 - (1) Nissan 300ZX RPM Adapter (7009-2223-01)
 - (1) Quad 4 / Nissan RPM Adapter (6005-0181-01)
 - (2) In-Line Filter (1-4281)
 28. Connect the Antenna RPM Cable Assembly (6004-0614-01) to the Antenna Figure 8 Loop (7009-2037-01). Attach the other end of the Antenna RPM Cable Assembly to the "ANT." connector on the rear of the analyzer.
 29. Referring to Figure 3, measure back 4" from the connector that attaches to the Figure 8 Loop. Place that point on the cable next to the Figure 8 Loop and place a Cable Tie (5878-0016) on it. This will stop the cable from being pulled out of the Antenna Cable Connector.

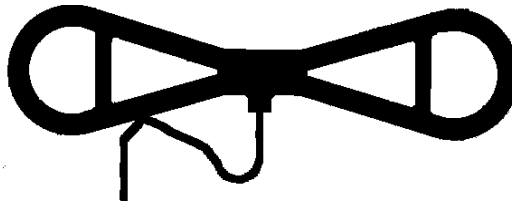

Figure 3, Antenna Tie Wrap Modification

30. Connect the Trigger Pickup (7009-1929) to the Trigger Pickup Adapter Lead (6004-0262-05).
31. Connect the 30 foot Blue Trigger Pickup Cable (6004-0566-01) to the Assembled pieces in step 30. Attach the other end of the 30 foot Blue Trigger Pickup Cable to the "TACH." connector on the rear of the analyzer.
32. Connect the Volt/Ohm Lead (6004-0462) to the "V / Ω" connector on the rear of the analyzer.
33. Connect the Exhaust Hose Assembly (3988-0230-01) to the filter bowls on the rear on the analyzer.
34. Connect the Dual Exhaust Hose (3988-0231-01) to the female quick disconnect fitting on the Exhaust Hose Assembly, installed previously.
35. Connect an Exhaust Probe (7009-1869) to both fittings on the end of the exhaust hoses.
36. Attach the two brass fittings (0647-0069) to the regulators (0131-0024).

37. Attach the regulators to the gas bottles (supplied locally).
38. Attach the hoses (EAA0136C0*A), with label, to the proper calibration tank brass fitting.
39. Attach the aspirator hose to the Aspirator (located below the primary filter bowl). Route the other end of the aspirator hose through the base of the analyzer. Ensure that the hose goes through the top and bottom holes of the base.
40. Unpack the Gas Cap Pressure Tester Assembly (EAA0144C00A), and place all the accessories to that unit in the storage drawer.
41. Connect the Gas Cap Pressure Tester Cable to the Gas Cap Pressure Tester and the other end to the port on the rear of the SIS label "**COM F**".
42. Remove the Oxygen Sensor cover, retain the hardware.
43. Screw Oxygen Sensor into Oxygen Block and attach the Oxygen Sensor Harness to the Oxygen Sensor.
44. Re-mount the Oxygen Sensor Cover.
45. Give the Product and Warranty Registration documentation to the Analyzer Owner and ensure that it is filled out and mailed.
46. Place the Service Call Label (EAL0264C00A) on the rear of the machine, in a place that is easily readable by the customer.
47. Provide the Owner with the Operators' Manuals.
48. Completely fill out the Quality Control Questionnaire (0692-1834-01) and mail it according to the instructions printed on the form.
49. Power up the analyzer and wait until the analyzer boots.
50. Ensure the printer is on and press and hold **<SHIFT>**, and press **<SEL>**. This puts you in the Menu Mode.
51. Press **<GROUP>** until "**Rear Feed**" is displayed.
52. Press **<ITEM>** until "**Rear Feed, Form Tear-Off, Off**" is printed.
53. Press **<SET>** twice and it will print "**Rear Feed, Form Tear-Off, 1 sec**". This advances the paper to the tear bar automatically after printing a page.
54. Press **<PRINT>**, and ensure the printout matches Table 1, on the next page. Press and hold **<SHIFT>**, and press **<SEL>**, to return back to the Print Mode.
55. Reference the Texas Auditors Manual for installation and Setup of System Software.

Printer Control	Emulation Mode	IBM PPR
Font	Print Mode	LQ Courier
Font	Pitch	10 CPI
Font	Proportional Spacing	No
Font	Style	Normal
Font	Size	Single
Symbol Sets	Character Set	Set I
Symbol Sets	Language Set	American
Symbol Sets	Zero Character	Slashed
Symbol Sets	Code Page	USA
Rear Feed	Line Spacing	6 LPI
Rear Feed	Form Tear-Off	1 sec
Rear Feed	Skip Over Perforation	No
Rear Feed	Page Length	11 "
Bottom Feed	Line Spacing	6 LPI
Bottom Feed	Form Tear-Off	Off
Bottom Feed	Skip Over Perforation	No
Bottom Feed	Page Length	11 "
Top Feed	Line Spacing	6 LPI
Top Feed	Bottom Margin	Valid
Top Feed	Page Length	11 "
Top Feed	Wait Time	1 sec
Top Feed	Page Length Control	by MENU Setting
Set-Up	Graphics	Uni-directional
Set-Up	Receive Buffer Size	8K
Set-Up	Paper Out Override	No
Set-Up	Print Registration	0
<pre> SET <-----> </pre>		<pre> SHIFT+SET -----> </pre>
Set-Up	Operator Panel Function	Full Operation
Set-Up	Reset Inhibit	No
Set-Up	Print Suppress Effective	Yes
Set-Up	Auto LF	No
Set-Up	Auto CR	No
Set-Up	SI Select Pitch (10CPI)	17.1 CPI
Set-Up	SI Select Pitch (12CPI)	12 CPI
Set-Up	Time Out Print	Valid
Set-Up	Auto Select	No
Set-Up	Graphics Speed	Low
Set-Up	Centering Position	DEFAULT
Set-Up	Decollator	No
Parallel I/F	I-Prime	Buffer Print
Parallel I/F	Pin 18	+5v
Printer Control	Emulation Mode	IBM PPR

Table 1, Printer Menu Selections

SETUP COMPLETE