



**Model:** EEEA117A  
California  
Service Inspection System  
Analyzer Setup

**Page:** 1 of 6

# Installation Instructions

**INSTALLATION MUST BE PERFORMED  
BY  
QUALIFIED JOHN BEAN/EQUISERV PERSONNEL ONLY**

## INSTALLATION OVERVIEW:

The California Analyzer is shipped as a fully assembled analyzer, with the exception of the Keyboard, Monitor, Printer and accessories. The following instructions, along with the Monitor Base Kit Instructions (EAK0185L00A), and the Zero Air Kit Instructions (EAK0097C00AF) will provide you with the steps necessary to completely setup the analyzer.

## PARTS & ACCESSORIES:

PART NUMBER	DESCRIPTION	QTY
0131-0031-01	Gas Bottle Regulator	2
0301-0944-01	Filter Element, 75 Micron	4
0301-0945-01	Filter Element, 8 Micron	4
0424-0804-01	Velcro, Loop	18"
0424-0804-02	Velcro, Hook	18"
0507-0025-01	Probe, Anti-Dilution	1
0528-0033-01	Printer, HP Desk Jet	1
0528-1088-01	Printer Paper	1
0528-1095-01	Printer Ribbon Cartridge	1
0552-0072-01	1.44 Megabyte Floppy Unformatted	1
0552-0104-01	DOS 6.22 Package	1
0552-0117-01	Keyboard	1
0552-1086-01	Keyboard Cover Protector	1
0610-1511-04	Screw, Sheet Metal #8 X ¼	4
0647-0069	Brass Fitting	2
0692-1834-01	Quality Control Questionnaire, SEL 1043C	1
0692-2453-01	SIS Generic Banner	1
0692-2459-01	Installation Instruction	1
0692-2462-01	Operators Manual (Generic)	1
0787-0035	Probe Caps	2
1-4281	Filter, In-Line	2
1-7726	Screw, 10x32 x ½" HWHTT	6
2161-0023	Lead Hanger	6
3-608	Monitor, 15" SVGA Color	1
3988-0230-01	Hose Assembly, Exhaust 3/16	1
3988-0231-01	Hose Assembly, Exhaust Dual 3/16	1
5-2645	Clamp, Cable	1
5878-0016	Cable Tie, 14.5"	1

PART NUMBER	DESCRIPTION	QTY
6004-0262-05	Cable Assembly, Trigger Pickup	1
6004-0462	Test Lead, Volt / Ohm	1
6004-0566-01	Cable Assembly, Tachometer Lead	1
6004-0614-01	Antenna Cable	1
6005-0181-01	Adapter Assembly, Nissan Pulsar/Quad 4	1
6005-0184-01	Adapter, Rpm, BMW	1
6005-0184-02	Adapter, Rpm, Acura	1
6-622	Cable, OBD II Communications	1
7009-1869	Probe Exhaust Assembly.	2
7009-1929	Trigger Pickup Assembly.	1
7009-2037-01	Antenna, RPM (Figure 8)	1
7009-2223-01	Adapter, RPM, Nissan 300ZX Turbo	1
EAA0136C01A	Hose, Low Scale Gas ID Tag	1
EAA0136C02A	Hose, Mid Scale Gas ID Tag	1
EAA0145C00A	Gas Cap Tester	1
EAA0190L10A	Hanger, Lead	4
EAK0097C00AF	Kit, Zero Air Kit	1
EAK0185L00A	Kit, Monitor Base	1
EAL0234C00A	Label, Keyboard	1
EAL0264C00A	Label, Service Call	1
EASC071C82A	Bracket, Bar Code Scanner Storage	1
EASC071C83A	Bracket, Bar Code Scanner Mounting	1
EAW0096C00A	Monitor AC Power Cable	1
EAW0166L03A	Cable, Gas Cap Tester Interface	1
EAW0179L00A	Cable, Dyno Interface	1
EERC102A	Remote Control	1
EESP107FD	Windows 95	1
YA9020	Wheel Chock	1
ZEEEE117A	Operator's Manual	1

**REQUIRED TOOLS:** \_\_\_\_\_

- **GAS BOTTLE (0271-0062-01, 0271-0066-01)**
- **COMPLETE TOOL KIT**
- **ANTI-STATIC KIT**
- **SERVICE KEYS (from Technical Support), (215 and 225)**

**INSTALLATION INSTRUCTIONS:** \_\_\_\_\_



**NOTE:** *If the SIS was soft shipped (shipped without a carton) skip steps 1 through 4.*

1. Cut the Straps, and remove the top of the carton, top packing, and carton sides.
2. Slide the SIS and carton base off of the pallet, and split the corners of the base carton.
3. Lean the SIS so that one half of the foam base can be removed.
4. Lean the SIS so the other half of the foam base can be removed.
5. Remove all shipping tape from the SIS Cabinet.
6. Check for proper AC and GROUND connections at the outlet. This can be accomplished by using an AC outlet polarity checker, that can be obtained at a local hardware store.
7. Place the Operate/Standby switch into the operate position.

8. Verify that the parts and accessories listed are all present with the Analyzer.
9. Following the instructions in the Monitor Base Kit (EAK0185L00A), attach the (3-608) to the SIS.
10. Remove and discard the Monitor AC Power Cable that was shipped with the monitor.
11. Connect the Monitor AC Power Cable (EAW0096C00A) to the back of the monitor, and to the AC port on the rear panel of the analyzer labeled "**Video Power**".
12. Connect the Data cable coming from the rear of the monitor to the port on the rear of the analyzer, below the monitor, labeled "**Video**".

**NOTE:** *The Blue and Red connectors, for the Speakers in the monitor, do not get connected. They can be tie wrapped to the Video Data Cable.*

13. Remove the bubble wrap from the keyboard, and ensure that it is plugged into the keyboard extension under the monitor.

**NOTE:** *The following step may be complete at the factory.*

14. Attach the Keyboard Label (EAL0234C00A) to the top of the keyboard (0552-0117-01).
15. Attach the Keyboard Cover (0552-1086-01) to the top of the keyboard.

**NOTE:** *In the following step the velcro may already be placed on the keyboard.*

16. In order to mount the Velcro, turn the keyboard upside down. Peel the backing off the hook side of a 14" piece of Velcro (0424-0804-02) and attach to keyboard. Attach soft side (Loop) of a 14" piece of Velcro (0424-0804-01) to Velcro Hook. Remove backing, exposing adhesive and place keyboard in its proper position and press firmly.
17. Cut the two 4" pieces of Velcro (0428-0804-01 and 0428-0804-02) in half, such that you are left with four pieces of Velcro 2" long.
18. Peel the backing off the hook side of a 2" piece of Velcro (0424-0804-02) and attach to the bottom of the printer power supply. Attach soft side (Loop) of a 2" piece of Velcro (0424-0804-01) to Velcro Hook. Remove backing, exposing adhesive and place power supply in the back left hand corner of the printer compartment.
19. Route the AC Wall Receptacle end of the printers power supply cord, through the divider panel between the computer and the printer. Plug the power cord into the power adapter cable attached to the computers power supply.
20. Remove the Printer (0528-0033-01) from its carton. Referring to Figure 1, remove all tape from the printer and remove the carriage cover to gain access to the print head. Remove the plastic stop that secures the print head.

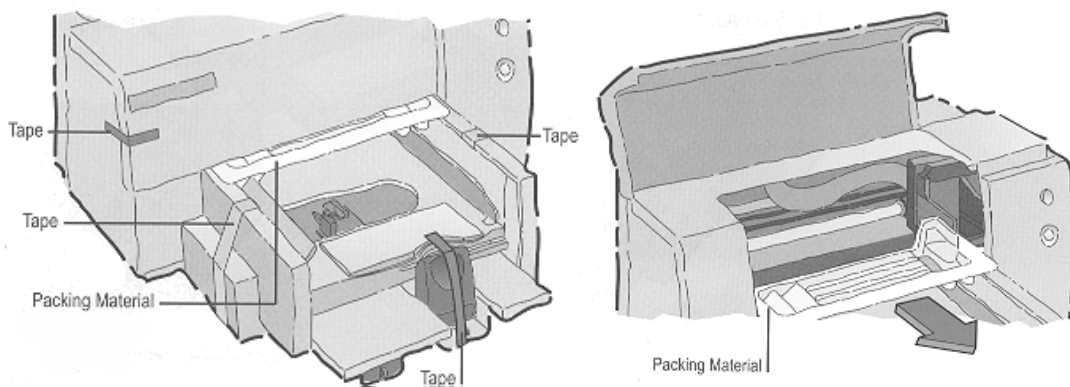
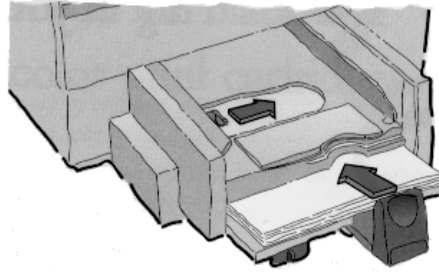

Figure 1, Packing Material Removal

21. Referring to Figure 2, Load the printer paper into the Printer.



**Figure 2, Printer Paper Installation**

19. Place the printer in the opening below the keyboard. Attach the power cable and data cable, already located in the analyzer, to their respective ports on the back of the printer.
20. Attach a wire tie to the rear of the printer, just behind the power connector of the printer to secure both the Printer Power and Data Cables.
21. Press the power button to turn on the printer.
22. Carefully remove the tape from the bottom of the printer cartridges.
23. Referring to Figure 3, place the printer cartridges into their cradles. Push the Printer Cartridges back toward the printer to snap them into place.

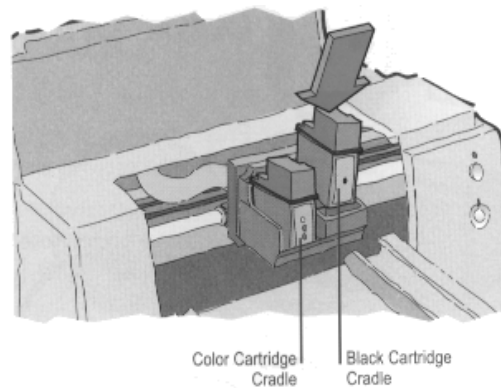

**Figure 3, Printer Cartridge Installation**

24. Close the printer cover.
25. Using the six 10-32x1/2" screws (1-7726), install the six hangers (2161-0023) into the slots on the rear corners of the Analyzer. Three slots are located on each corner of the tester's stand.
26. Attach the four (4) Lead Hangers (EAA0190L00A) to the Unit Handles.

**NOTE:** *The Bar Code Reader Bracket can be mounted on either side of the Analyzer.*

27. Mount the Bar Code Scanner Mounting Bracket (EASC071C83A) to the underside of the Computer Cabinet Sheet Metal Assembly, using two of the #8 X 1/4 Sheet Metal Screws (0610-1511-04).
28. Mount the Bar Code Scanner Storage Bracket (EASC071C82A) to the Mounting Bracket just installed, using two of the #8 X 1/4 Sheet Metal Screws (0610-1511-04).
29. Remove the Gas Cap Tester (EAA0145C00A) from its packaging.
30. Attach the RJ45 end of the Gas Cap Tester Interface Adapter Cable (EAW0166L03A) to the RJ45 connector on the Gas Cap Tester.
31. Measure back two inches on the end of the Gas Cap Tester Cable just connected. Attach the Cable Clamp (5-2645) at this point on the cable.

32. Remove the screw in the bottom left hand corner of the control panel on the Gas Cap Tester. Using the Screw just removed attach the secure the cable clamp to the Gas Cap Tester.
33. Attach the other end of the Gas Cap Tester Cable to the port labeled "**COM A2**" on the rear of the analyzer.
34. Place the following items in the storage drawer below the computer and printer section:
  - (4) 75 Micron Filter Elements (0301-0944-01)
  - (4) 8 Micron Filter Elements (0301-0945-01)
  - (1) Anti-Dilution Probe (0507-0025-01)
  - (1) Printer Cartridge (0528-1095-01)
  - (1) DOS 6.22 Package (0552-0104-01)
  - (2) Exhaust Probe Leak Check Caps (0787-0035)
  - (1) BMW RPM Adapter (6005-0184-01)
  - (1) Acura RPM Adapter (6005-0184-02)
  - (1) Nissan 300ZX RPM Adapter (7009-2223-01)
  - (1) Quad 4 / Nissan RPM Adapter (6005-0181-01)
  - (1) Remote Control (EERC102A)
  - (1) Windows 95 (EESP107FD)
  - (2) In-Line Filter (1-4281)
35. Connect the Antenna RPM Cable Assembly (6004-0614-01) to the Antenna Figure 8 Loop (7009-2037-01). Attach the other end of the Antenna RPM Cable Assembly to the "**ANT.**" connector on the rear of the analyzer.
36. Referring to Figure 4, measure back 4" from the connector that attaches to the Figure 8 Loop. Place that point on the cable next to the Figure 8 Loop and place a Cable Tie (5878-0016) on it. This will stop the cable from being pulled out of the Antenna Cable Connector.



**Figure 4, Antenna Tie Wrap Modification**

37. Connect the Trigger Pickup (7009-1929) to the Trigger Pickup Adapter Lead (6004-0262-05).
38. Connect the 30 foot Blue Trigger Pickup Cable (6004-0566-01) to the assembled pieces in step 38. Attach the other end of the 30 foot Blue Trigger Pickup Cable to the "**TACH.**" connector on the rear of the analyzer.
39. Connect the Volt/Ohm Lead (6004-0462) to the "**V /  $\Omega$** " connector on the rear of the analyzer.
40. Connect the OBD II Communications Cable (6-622) to the rear panel connector labeled "**COM A3**".
41. Connect the Exhaust Hose Assembly (3988-0230-01) to the filter bowls on the rear on the analyzer.
42. Connect the Dual Exhaust Hose (3988-0231-01) to the female quick disconnect fitting on the Exhaust Hose Assembly, installed previously.
43. Following the instructions in the Zero Air Kit (EAK0097C00AF), to mount the Zero Air Bottle to the Analyzer.
44. Connect an Exhaust Probes (7009-1869) to both fittings on the end of the exhaust hoses.

45. Attach the two brass fittings (0647-0069) to the regulators (0131-0031-01).
46. Attach the regulators to the gas bottles (supplied locally).
47. Attach the hoses (EAA0136C0\*A), with label, to a calibration tank brass fitting, and attach the other end to the rear panel calibration ports.
48. Place the Service Call Label (EAL0264C00A) on the rear of the machine, in a place that is easily readable by the customer.
49. Present the SIS Banner (0692-2453-01) to the customer and offer to hang it in a central location.
50. Provide the Owner with the Operators' Manuals.
51. Completely fill out the Quality Control Questionnaire (0692-1834-01) and mail it according to the instructions printed on the form.
52. Power up the analyzer and wait until the analyzer boots.
53. Reference the California's Auditors Manual for installation and Setup of System Software.

**NOTE:**     *The Wheel Chock and Dyno Interface Cable will be used in conjunction with the Dynamometer.*

**NOTE:**     *The 1.44 Megabyte Unformatted Floppy Disk (0552-0072-01) will be used when installing software into the Service Inspection System.*

**SETUP COMPLETE**