

ECO-134™ BID SPECIFICATION

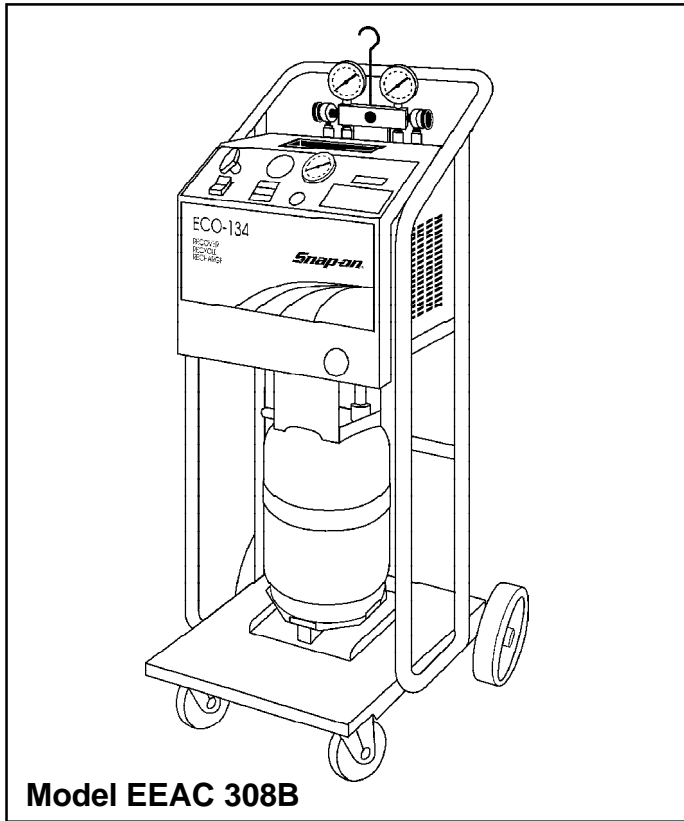

Model EEAC 308B

PRODUCT FUNCTIONS/FEATURES

- Recover/recycle, evacuation and recharge of auto A/C systems (R-134a refrigerant)
- Microprocessor-controlled
- Meets all current SAE, UL and CSA standards for operation, performance and purity
- Electronic scale for measurement of recovery tank amounts (dispensed, recycled and remaining)
- Manual recover/recycle sequence with oil capture procedure
- Single pass recycling system
- Manual purge of non-condensable gases
- Sight glass with color eye moisture indicator for refrigerant quality
- Manual A/C system evacuation sequence with leak test procedure
- Manual recharge sequence with charge amount measured by weight
- Filter/dryer for removal of moisture and particulate matter
- Hour meter indicates filter dryer change
- Oil separator for removal of oil and other contaminants
- Oil drain valve with graduated oil cup
- High pressure shut-off
- Automatic tank full shut-off for recovery tank
- Warning Indicators:
 - High pressure
 - Tank full
 - Overload
- Reflective liquid crystal display
- LCD displays:
 - recovery tank status (full/empty)
 - gross weight
 - amount charged/recovered
- Recovery tank amount display in lbs.-ozs.
- Standard and optional tool trays

- Optional Refrigerant Identifier attaches laterally to unit and verifies purity of refrigerants in vehicles, storage containers and A/C service equipment to 98% accuracy.

PERFORMANCE SPECIFICATIONS

- Operating Temperature Range: 50 - 120 degrees F.
- Relative Humidity: Up to 80% non-condensing
- Unit Operating Pressure Range: 30 in.Hg to 300 psi
- Manifold Gauge Set Ranges:
 - High Side: max. 500 psi
 - Low Side: max. 300 psi
- Refrigerant Charge Amount: 0 - 25 lbs
- Recovery Amount: 0 - 25 lbs.
- Compressor: 1/3 hp reciprocating
- Condenser: fan-cooled
- Recovery Rate: 1 lb. per min. maximum
- Control Panel Pressure Gauge: max. 400 psi
- Control Panel Temperature Gauge : -58 - 302 deg F.

CAPACITIES

- Recovery: up to 25 pounds
- Pump displacement: 1.12 CFM
- Vacuum: 29 in Hg
- Oil separator: 12 oz.

POWER/WEIGHT/DIMENSIONS

- Dimensions: 45" H x 18" W x 24" D
- Shipping Weight: 128 pounds
- Power: Model EEAC 308B -- 108 - 132 VAC, 1 PH, 50/60 Hz @ 4 amps

STANDARD PARTS/ACCESSORIES

- 0647-0287-08 Service Fitting, low side
- 1-15080 Adapter Fitting, low side
- 0647-0287-07 Service Fitting, high side
- EAAO158C00A Recovery Tank, 30lb.
- 4719-0055-02 R-134a anti-blowback valve
- EAH0014C01A Gauge Assembly R-134a with hoses (USA, Japan)

OPTIONAL PARTS/ACCESSORIES

- EAK0095C01AB Filter/Dryer Kit
- EAK0029C00AB Oil Change Kit
- EAH0014C12A Gauge Assembly with hoses (Europe)
- EAK0027C00AS Vehicle Adaptor Repair Kit (O-rings)
- 1091-0301-01 Oil Injection Kit
- EAK0155L02A Refrigerant Identifier Kit
- EAK0139L01AB Tool Tray
- EAKAC307ACV Polyester Protective Cover

SAFETY INFORMATION

- Products may have inherent risk to the user.
- Read, understand and follow all safety messages on the product, user manual and vehicle to be serviced before operating ECO-134a.
- Improper use may result in injury.

Snap-on Diagnostics

Specifications are subject to change without notice.
Snap-on is a registered trademark of Snap-on Technologies, Inc.
ECO is a trademark of Snap-on Technologies, Inc.