

Table of Contents

| | |
|--|------|
| Safety | I |
| Introduction | 1-1 |
| Refrigerant Gases | 1-2 |
| Refrigerant Handling | 1-3 |
| Refrigerant Safety | 1-3 |
| Refrigerant Substitute Warning | 1-4 |
| Functional Description | 1-5 |
| Front Panel | 1-5 |
| Back Panel | 1-8 |
| R-12 Accessories | 1-10 |
| R-134a Accessories | 1-11 |
| Specifications | 1-12 |
| General | 1-12 |
| Operating | 1-12 |
| Storage | 1-13 |
| Capacities | 1-13 |
| Installation and Operation | 2-1 |
| Connecting Service Hoses To ECO | 2-1 |
| Component Identification | 2-2 |
| Preparing and Installing Recovery Tank | 2-3 |
| Operation | 2-6 |
| Preliminary Checks | 2-7 |
| Connecting Service Hoses To Vehicle | 2-9 |
| Recover/Recycle Refrigerant From Vehicle | 2-10 |
| Purging Non-condensable Gas | 2-11 |
| Evacuating A/C System | 2-12 |
| Charging A/C System | 2-13 |
| Displaying Refrigerant Amount | 2-14 |
| Tank Full/Empty | 2-14 |
| Removing Recovery Tank | 2-14 |
| Evacuating Service Hoses | 2-14 |
| Adding Refrigerant To ECO | 2-15 |
| Maintenance | 3-1 |
| Equipment Tips | 3-1 |
| Master Filter | 3-2 |
| Moisture Indicator | 3-2 |
| Master Filter Maintenance Schedule | 3-3 |
| Changing the Master Filter | 3-4 |
| Pump | 3-5 |
| Maintaining the Pump | 3-5 |
| Prolonged Storage of Kool Kare | 3-7 |
| Troubleshooting | 3-8 |
| Replacement Parts | 3-9 |
| Optional Accessories | 3-9 |

Table of Contents

Table of Illustrations

Introduction

| | |
|---|------|
| <i>Figure 1-1: Front Panel</i> | 1-5 |
| <i>Figure 1-2: Back Panel</i> | 1-8 |
| <i>Figure 1-3: R-12 Accessories</i> | 1-10 |
| <i>Figure 1-4: R-134a Accessories</i> | 1-11 |

Installation and Operation

| | |
|--|-----|
| <i>Figure 2-1: Service Hoses and Gauge Sets</i> | 2-2 |
| <i>Figure 2-2: Recovery Tank and Temperature Probe</i> | 2-6 |
| <i>Figure 2-3: Service Hose Connections to Vehicle</i> | 2-9 |

Maintenance

| | |
|---|-----|
| <i>Figure 3-1: Moisture Indicator Chart</i> | 3-2 |
| <i>Figure 3-2: Master Filter Maintenance Schedule</i> | 3-3 |
| <i>Figure 3-3: Master Filter</i> | 3-4 |
| <i>Figure 3-4: Pump</i> | 3-5 |

Trademark Acknowledgements

Snap-on[®] is a trademark of Snap-on Technologies Incorporated.

Sun[®] is a trademark of Snap-on Tools Company.

ECO is a registered trademark of **Snap-on** Tools Co.

Copyright Information

ECO User's Manual ©1996 **Snap-on** Incorporated.

The information, specifications and illustrations in this manual are based on the latest information available at the time of printing. **Sun** reserves the right to make changes at any time without notice.

Using this Manual

This manual contains instructions for use and setup of the unit. A table of contents and table of illustrations are provided to make this manual easy to use.

Some of the information shown in text or illustrations is obtained using optional equipment. A **Snap-on/Sun** Sales Representative can determine option availability.

Conventions

This section contains a list of conventions used in text.

Service and Manifold Hand Valves

References in text to opening and closing manifold hand valves assume:

- Clockwise closes valves, and
- Counterclockwise opens valves.

References in text to opening and closing service hose valves assume:

- Valve is open with lever parallel to hose, and
- Valve is closed with lever perpendicular to hose.

References in text to opening and closing 134a couplers assume:

- Counterclockwise closes valves, and
- Clockwise opens valves.

Check Note

A check note provides additional information about the subject in the preceding paragraph.

Example:

- ✓ For additional information refer to *Chapter 2—Connecting Service Hoses to **ECO*** and *Chapter 2—Connecting Service Hoses to Vehicle*.

Equipment Tips

Equipment tips provide information that applies to specific equipment. Each tip is introduced by this icon for easy identification.

Example:

- Never attempt to change the recovery tank during unit operation. For additional information refer to *Chapter 2—Removing Recovery Tank*.

Equipment Damage

Situations arise during testing that could damage the vehicle or the test equipment. The word **IMPORTANT** signals these situations.

Example:

IMPORTANT

Failure to follow these instructions could damage compressor.

Safety Messages

Safety messages are provided to help prevent personal injury and equipment damage. All safety messages are introduced by a signal word indicating the hazard level. The types of safety messages are:

▲ DANGER

Indicates an imminently hazardous situation which, if not avoided, will result in death or serious injury to the operator or to bystanders.

▲ WARNING

Indicates a potential hazard which, if not avoided, could result in death or serious injury to the operator or to bystanders.

▲ CAUTION

Indicates a potential hazard which, if not avoided, may result in minor or moderate injury to the operator or to bystanders.

Some safety messages contain visual symbols with signal words.

Example:



Engine systems can malfunction expelling fuel, oil vapors, hot steam, hot toxic exhaust gases, acid, refrigerant and other debris.

Wear safety goggles and protective gloves, user and bystander.

Engine systems that malfunction can cause injury.

Terms

Use the following definitions as a foundation to help understand **ECO** processes and/or components.

Virgin Tank

A refrigerant tank, disposable or refillable, that contains new refrigerant. When empty, disposable virgin tank must be evacuated and cannot be refilled. Dispose of evacuated tank in accordance with local, state and federal regulations that apply in your area. A refillable virgin tank should be returned to your supplier.

Recovery Tank

A refrigerant tank designed to store refrigerant recovered from a vehicle or transferred from a virgin tank.

Recover

The process of removing refrigerant from a system to prevent release of refrigerant into the atmosphere. On **ECO**, this process is part of recycle.

Recycle

On **ECO**, the process of removing refrigerant from a system, filtering, drying and storing it in the recovery tank.

- ✓ Recycle is the only process that removes refrigerant. There is not a separate recovery process.
- ✓ ECO is a single pass unit. This means refrigerant is filtered and dried before reaching the recovery tank. Once in the recovery tank, it is ready for reuse, after manual purging, if necessary. There is no separate "recycle" process to perform.

Evacuate

The process of drawing a vacuum on a refrigerant system to remove air and moisture. On **ECO**, this process is known as vacuum.

Charge

The process of filling an air conditioning system with refrigerant.

Purging

The process of bleeding off non-condensable gases from the recovery tank.

Stable Scale

Situation where reading from refrigerant weight measuring device is steady. Moving **ECO** causes liquid refrigerant to slosh in recovery tank, resulting in unsteady scale reading. Avoid moving **ECO** before taking scale readings.

Safety Information

Safety Notice

For your safety, read this manual thoroughly before operating **ECO**.

ECO is intended for use by properly trained, skilled professional automotive technicians. The safety messages presented below and throughout this user's manual are reminders to the operator to exercise care when using this unit.

There are many variations in procedures, techniques, tools, and parts for servicing vehicles, as well as in the skill of the individual doing the work. Because of the vast number of test applications and variations in the products that can be tested with this instrument, **Sun** Electric cannot possibly anticipate or provide advice or safety messages to cover every situation. It is the automotive technician's responsibility to be knowledgeable of the system that is to be tested. It is essential to use proper service methods and test procedures and to perform tests in an appropriate and acceptable manner that does not endanger your safety, the safety of others in the work area, or the vehicle or equipment being tested.

It is assumed that the operator has a thorough understanding of vehicle air conditioning systems before using **ECO**. This understanding of principles and operating theories is necessary for competent, safe and accurate use of this instrument.

Before using **ECO**, always refer to and follow safety messages and applicable test procedures provided by the manufacturer of the vehicle or equipment being tested.

Read All Instructions

Read, understand and follow all safety messages and instructions in this manual and on the test equipment. Safety messages in this section of the manual contain a signal word with a three-part message and, in some instances, an icon.

The signal word indicates the level of hazard in a situation.

- **DANGER** indicates an imminently hazardous situation which, if not avoided, will result in death or serious injury to the operator or bystanders.
- **WARNING** indicates a potentially hazardous situation which, if not avoided, could result in death or serious injury to the operator or bystanders.
- **CAUTION** indicates a potentially hazardous situation which, if not avoided, may result in moderate or minor injury to the operator or bystanders.

Safety messages in this section contain three different type styles.

- Normal type states the hazard.
- **Bold type** states how to avoid the hazard.
- *Italic type* states the possible consequences of not avoiding the hazard.

An icon, when present, gives a graphical description of the potential hazard.

IMPORTANT SAFETY INSTRUCTIONS



Risk of suffocation.

- Vehicle exhaust gases contain carbon monoxide.
- Refrigerant gas can displace air in work area.

Use ECO in locations with mechanical ventilation providing at least four air changes per hour.

Suffocation will cause injury.

Power



Risk of electric shock and fire.

- **To avoid electric shock the power cord protective grounding conductor must be connected to a properly grounded AC outlet.**
- **Use proper A.C. outlet for unit to operate correctly. See unit ID plate on back of unit. Extension cords are not recommended. If an extension cord must be used, use:**
 - **16 AWG for cords up to 50', and**
 - **14 AWG for cords greater than 50' but less than 100'.**
- **Connect power cord to properly grounded outlet. Do not remove or bypass the grounding pin.**

Electric shock and fire can cause injury.

Refrigerant



Risk of expelling refrigerant under pressure.

- **Wear safety goggles and protective gloves, user and bystander.** If any refrigerant gets into eyes, flush with water and seek a doctor's aid immediately, even though irritation may cease.
- **Do not remove master filter while under pressure.** Perform maintenance procedure for removing master filter in *Chapter 3—Changing the Master Filter*.
- **Prevent refrigerant from contacting the skin.**
Expelled refrigerate can cause injury.



Risk of explosion.

- **Do not use compressed shop air for leak detection or to pressure test a system containing refrigerant.** Refrigerant can form combustible mixtures at pressures above atmospheric and with air concentrations greater than 60% by volume.
- **Do not heat a container of refrigerant above 125°F (52°C).**

Explosion can cause injury.



Risk of fire.

- **Do not use this equipment in the vicinity of spilled or opened containers of gasoline.**
- **Do not use ECO or leak detector equipment if R-12 substitutes are suspected.** R-12 refrigerant substitutes may be flammable.

Fire can cause injury.



Risk of poison.

- **Avoid breathing air conditioning refrigerant and lubricant vapor or mist.**
- **Do not allow refrigerant to contact open flame or be drawn into a running engine.** This can cause refrigerant to become poisonous phosgene gas.
- **Use ECO to remove refrigerant from air conditioning systems.**

Exposure can irritate eyes, nose and throat.

Safety Information

General



Engine systems can malfunction expelling fuel, oil vapors, hot steam, hot toxic exhaust gases, acid, refrigerant and other debris.

Wear safety goggles and protective gloves, user and bystander.

Engine systems that malfunction can cause injury.



Engine compartment contains electrical connections and hot or moving parts.

- **Keep yourself, test leads, clothing and other objects clear of electrical connections and hot or moving engine parts.**
- **Do not place test equipment or tools on fenders or other places in the engine compartment.**

Contact with electrical connections and hot or moving parts can cause injury.



Service hoses can not withstand high temperatures or severe mechanical stress.

Keep the service hoses away from moving or hot engine parts.

Service hoses can split or burst causing injury.



Risk of explosion if improper tank is used.

Do not use any tank with this equipment other than part number EAA0157C00A for R-12 or EAA0158C00A for R-134a. These tanks are D.O.T. certified for refilling. D.O.T certified tanks are marked "D.O.T. 4BA 350" or "D.O.T. 4BA 400".

Explosion can cause injury.



Removing tubing assemblies from the pump may discharge refrigerant.

Wear safety goggles and protective gloves, user and bystander.

Refrigerant may cause injury.

WARNING

A test vehicle may move if not properly prepared.

- **Block the drive wheels before performing a test with the engine running. Unless instructed otherwise, set the parking brake and put the gear selector in neutral (manual transmission) or park (automatic transmission). If the vehicle has an automatic parking brake release, disconnect the release mechanism for testing and reconnect when testing is completed.**
- **Do not leave a running engine unattended.**

A moving vehicle can cause injury.

CAUTION

Risk of injury.

This equipment should be operated by qualified personnel.

*Operation of **ECO** by anyone other than qualified personnel may result in injury.*

CAUTION

Hose couplings are not self closing.

Always close the valves on the gauge set before disconnecting a hose.

Loosened hose couplings can leak refrigerant to the atmosphere.

CAUTION

Misdiagnosis may lead to incorrect or improper repair and/or adjustment.

Do not rely on erratic, questionable, or obviously erroneous test information or results. If test information or results are erratic, questionable, or obviously erroneous, make sure that all connections are correct and that the test procedure was performed correctly. Refer also to the Maintenance/Troubleshooting section and perform tests and make repairs as required. If test information or results are still suspicious, do not use them for diagnosis. Contact your *Snap-on/Sun* Representative.

Improper repair and/or adjustment may cause vehicle or equipment damage or unsafe operation.

SAVE THESE INSTRUCTIONS

Introduction

Use **ECO** on automotive air conditioning systems to:

- Recover,
 - Remove refrigerant from vehicle,
- Recycle,
 - Filter, dry and store recovered refrigerant in a refillable tank,
- Evacuate,
 - Remove air and moisture from air conditioning system using a vacuum pump to draw the system into a deep vacuum, and
- Recharge,
 - Refill the air conditioning system with a specified amount of refrigerant.

ECO is a single pass design. This means recovered refrigerant is filtered and dried before entering the recovery tank. Refrigerant in the tank is always ready for use, after manual purging, if necessary. *See Chapter 2 - Recovering Refrigerant From Vehicle.* There is no need to perform a separate recycle function. Recover, evacuate and recharge functions are performed manually.

This manual applies to the following **ECO** models:

| Model Number | Refrigerant Type | Voltage |
|--------------|------------------|---------|
| EEAC107A | R-12 | 120 VAC |
| EEAC108A | R-134a | 120 VAC |

References in text to **ECO** apply to all models. When a difference exists, the difference is specified.

ECO includes:

- A Liquid Crystal Display (LCD),
 - Standard gauge set with service hoses, fittings, and adaptors,
 - 30 pound capacity recovery tank and electronic scale,
 - Master filter, and
 - Oil cup.
- ✓ Recovery tank is temperature-monitored to maintain accurate purging of non-condensable gases under all conditions.

Refrigerant Gases

Halogens are any of the five elements (fluorine, chlorine, bromine, iodine and astatine) that form part of group 7a of the Periodic Table of Elements. The fluorine and chlorine elements of this family are used to create a methane organic compound used to form dichlorodifluoromethane (CCL_2F_2), a halogenated hydrocarbon called CFC-12 (chlorofluorocarbon 12). This refrigerant gas is commonly known as Refrigerant-12, or R-12, and has been used as a refrigerant in mobile air conditioning systems for many years.

The new refrigerant in the halogenated hydrocarbon family, HFC-134a (CH_2FCF_3), or R-134a, is now being incorporated in mobile air conditioning systems. HFC stands for hydrofluorocarbon.

The environmental impact of mobile air conditioning refrigerant containing chlorine (R-12) has caused regulatory action that will eventually eliminate the use of such products. Regulatory action is necessary because when the chlorine content in R-12 is exposed to the atmosphere:

- It depletes the protective ozone layer in the atmosphere,
- It has relatively high global warming potential, and
- Its long atmospheric lifetime is approximately 120 years.

R-134a has been developed for new vehicle production but does not replace or directly substitute for R-12 in existing vehicles. R-134a does not contain chlorine, does not deplete the ozone layer in the atmosphere and has an atmospheric lifetime of about 15.5 years.

Environmental Protection Agency (EPA) and state regulations specify that:

- Provisions be made to certify all air conditioning service, installation and repair personnel,
- Refrigerant be recovered, recycled or reclaimed from automotive air conditioning systems, instead of allowing vapors to be expelled, or vented, into the atmosphere, and
- Refrigerant be recycled and reused, or properly disposed of, instead of allowing vapors to be expelled, or vented, into the atmosphere.

Mobile air conditioning service, installation and repair technicians must be qualified and certified.

Refrigerant Handling

Mobile air conditioning systems contain chemical mixtures that require special handling to avoid injury and to avoid venting refrigerant into the atmosphere.

Do not discharge any refrigerant gas, vapor or liquid from a refrigeration system into the atmosphere. If service is required that involves opening the refrigerant system, use a certified recovery system.

Refrigerant Safety



- Wear safety goggles and protective gloves, user and bystander. If any refrigerant gets into eyes, flush with water and seek a doctor's aid immediately, even though irritation may cease.
- Do not remove master filter while under pressure. Follow instructions for removing master filter. For additional information refer to *Chapter 3—Changing the Master Filter*.
- Prevent refrigerant from contacting the skin.
- Read, understand and follow *Safety Information* in the front of this manual.

WARNING

- Use *ECO* in locations with mechanical ventilation providing at least four air changes per hour.
- Avoid breathing air conditioning refrigerant and lubricant vapor or mist.
- Do not allow refrigerant to contact open flame or be drawn into a running engine. This can cause refrigerant to become poisonous phosgene gas.
- Use *ECO* to remove refrigerant from air conditioning systems.
- Read, understand and follow *Safety Information* in the front of this manual.

IMPORTANT

Tighten all tubing connections properly. Insufficient or excessive torque can result in loose joints or deformed parts. Either condition can result in refrigerant leakage.

Refrigerant Substitute Warning



- Do not use *ECO* or leak detector equipment if R-12 substitutes are suspected. R-12 refrigerant substitutes may be flammable.
- Read, understand and follow *Safety Information* in the front of this manual.

Aftermarket R-12 refrigerant substitutes are being sold that are dangerous or potentially flammable gases. These products contain a blend of butane, isobutane and propane and have the potential for explosion. Some of these products are:

- OZ-12,
- Refrigerant-176,
- Arctic Chill R-176, and
- GHG Refrigerant 12.

Some vehicles using OZ-12 can be identified by a label that may be placed in the engine compartment, but many cannot be identified. Studies are currently being conducted to develop a procedure to identify the type of refrigerant in a refrigerant system. State agencies and the Environmental Protection Agency (EPA) are moving to ban flammable substitutes.

If it is suspected that a refrigerant system contains a product of this type:

- Question customers about previous service,
- Be aware of any unfamiliar odor from the system,
- Do not use a leak detector,
- Do not use recycling equipment, and
- Contact your state fire marshall or local EPA office.

Functional Description

Front Panel

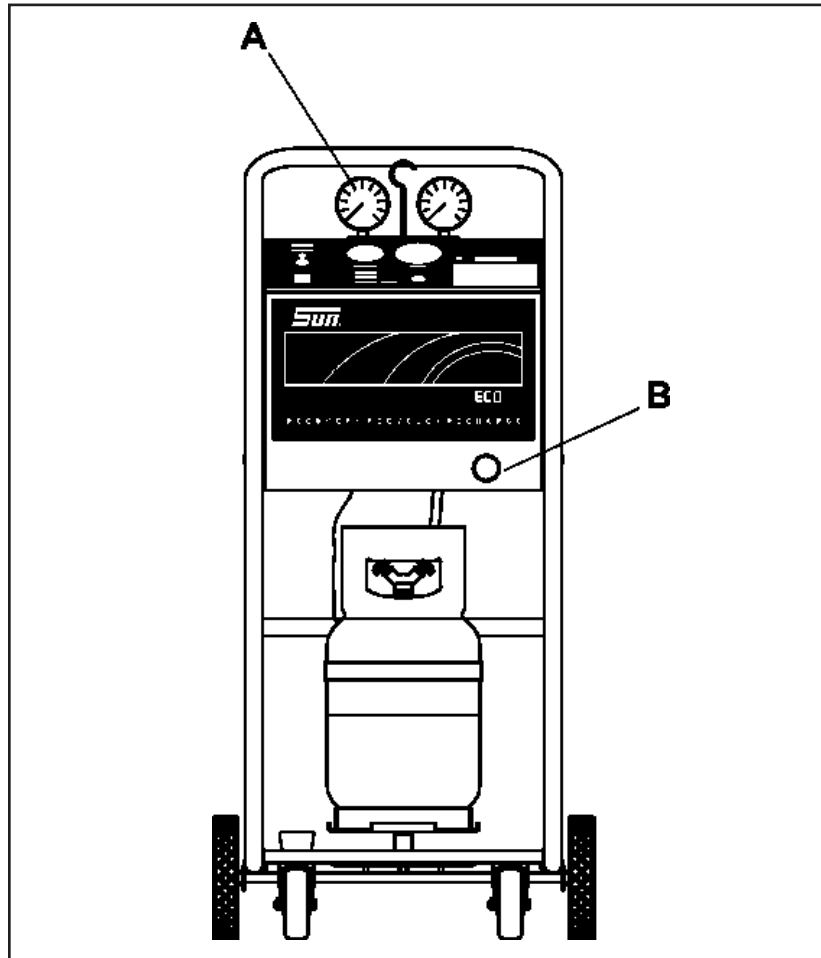

Figure 1-1: ECO R-12 Front View, ECO R-134a Similar

A — Gauge Set

High and low pressure gauge manifold set for monitoring air conditioning system pressures. Right hand valve opens and closes the high-side service hose passage to *ECO*. Left hand valve opens and closes the low-side service hose passage to *ECO*.

Control Panel

Houses display screen and control buttons.

Mode Button

Toggles LCD display between gross weight of recovery tank and tare weight, which zeroes the display for indication of charged or recycled amount.

Control Knob

Use to select Vacuum, Off, or Recycle.

Compressor Power Switch

Turns recovery compressor on and off. Must be on (I) for unit operation.

Unit On Indicator

Lights when power cord is connected to A.C. power.

Compressor On Indicator

Lights when compressor is running.

High Pressure Indicator

Lights when recovery tank pressure is above 300 psi. Tank pressure above 300 typically means non-condensable gas should be vented from recovery tank. For additional information refer to *Chapter 2–Purging Non-condensable Gas*.

Tank Full Indicator

Lights when recovery tank weight reaches 40 pounds.

Overload Indicator

Lights when compressor approaches a stall condition. End procedure in process to prevent compressor damage when overload indicator lights.

Temperature Display

Shows recovery tank temperature. Use this along with pressure/temperature chart on front panel when purging non-condensable gas. For additional information refer to *Chapter 2–Purging Non-condensable Gas*.

Pressure Gauge

Shows recovery tank pressure. Use this along with pressure/temperature chart on front panel when purging non-condensable gas. For additional information refer to *Chapter 2–Purging Non-condensable Gas*.

Purge Button

Use when purging non-condensable gas from recovery tank. For additional information refer to *Chapter 2–Purging Non-condensable Gas*.

LCD Display

Shows charged, recovered amounts or gross weight of recovery tank. Also Indicates software version, “Tank Full” and “Tank Empty” conditions.

B — Moisture Indicator

Shows moisture level in recycled refrigerant. When moisture indicator changes color, master filter maintenance is required. For additional information refer to *Chapter 3–Master Filter*.

Hour Meter (on left side of unit)

Registers recovery compressor run time to guide master filter maintenance. For additional information refer to *Chapter 3–Master Filter*.

Back Panel

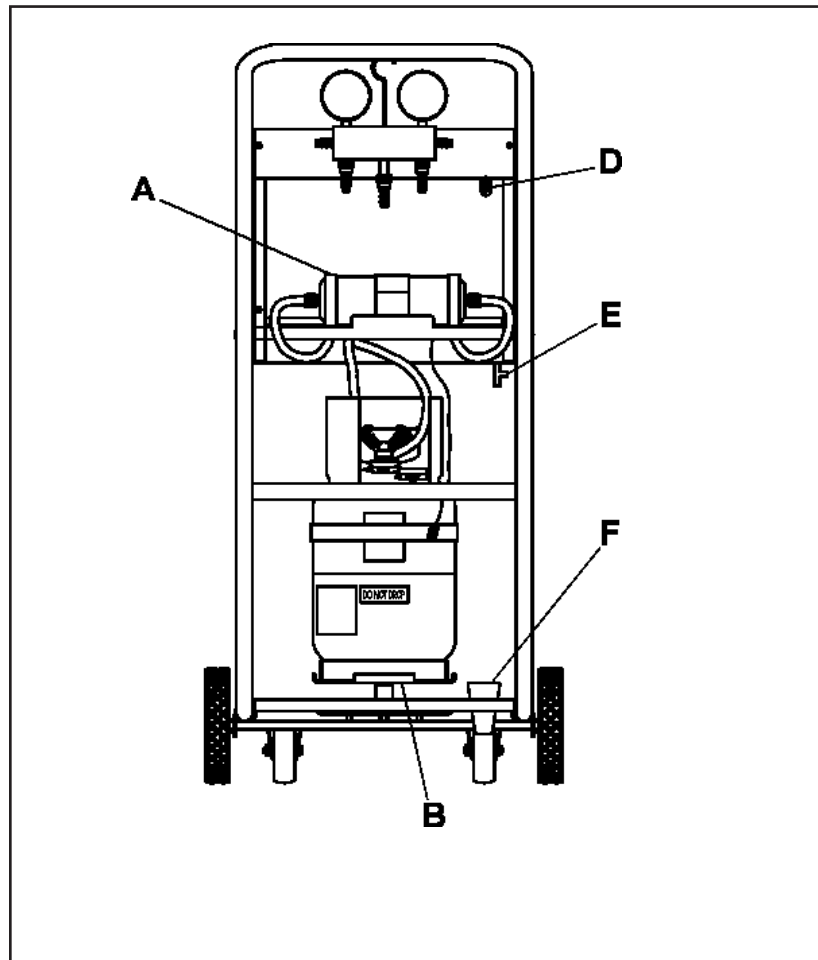

Figure 1-2: Back View

A — Master Filter

Consists of a 10 micron particulate filter and desiccant to remove moisture. For additional information refer to *Chapter 3—Changing the Master Filter*.

B — Scale

Electronically measures the amount of refrigerant dispensed, recycled, and remaining in the recovery tank.

C — Oil Separator (internal)

Removes oil and other contaminants from the refrigerant being recycled.

D — Service Port

The yellow service hose from the gauge set attaches to the service port.

E — Oil Drain Valve

Used to drain recovered oil from unit after every recover/recycle operation.

F — Oil Cup

Used to measure recovered oil.

R-12 Accessories

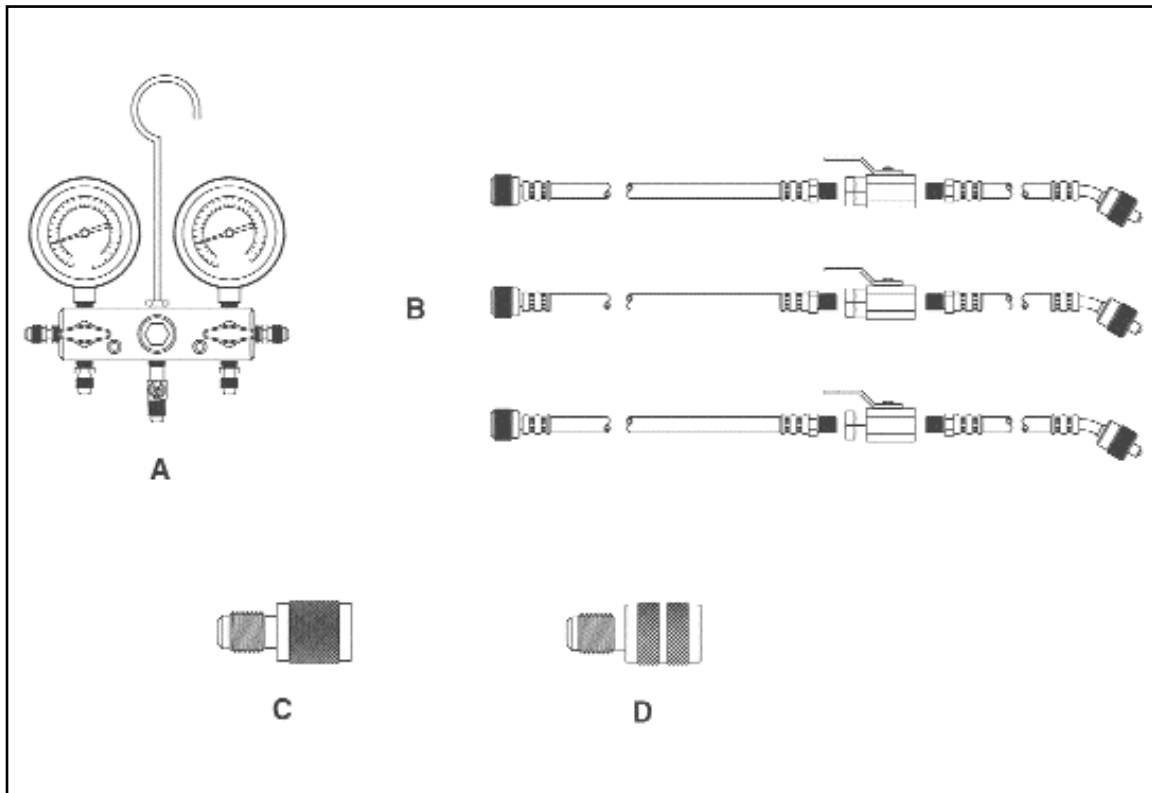

Figure 1-3: R-12 Accessories

A — Gauge Set

High and low pressure gauge manifold set monitors air conditioning system pressures. Right hand valve opens and closes the high-side service hose passage to **ECO**. Left hand valve opens and closes the low-side service hose passage to **ECO**.

B — Service Hoses

Red, blue and yellow hoses for connecting gauge set to vehicle and **ECO**. For additional information refer to *Chapter 2—Connecting Service Hoses to ECO* and *Chapter 2—Connecting Service Hoses to Vehicle*.

C — GM Adaptor

Connects to high-side service port on GM vehicles.

D — Ford Adaptor

Connects to high-side service port on Ford vehicles.

R-134a Accessories

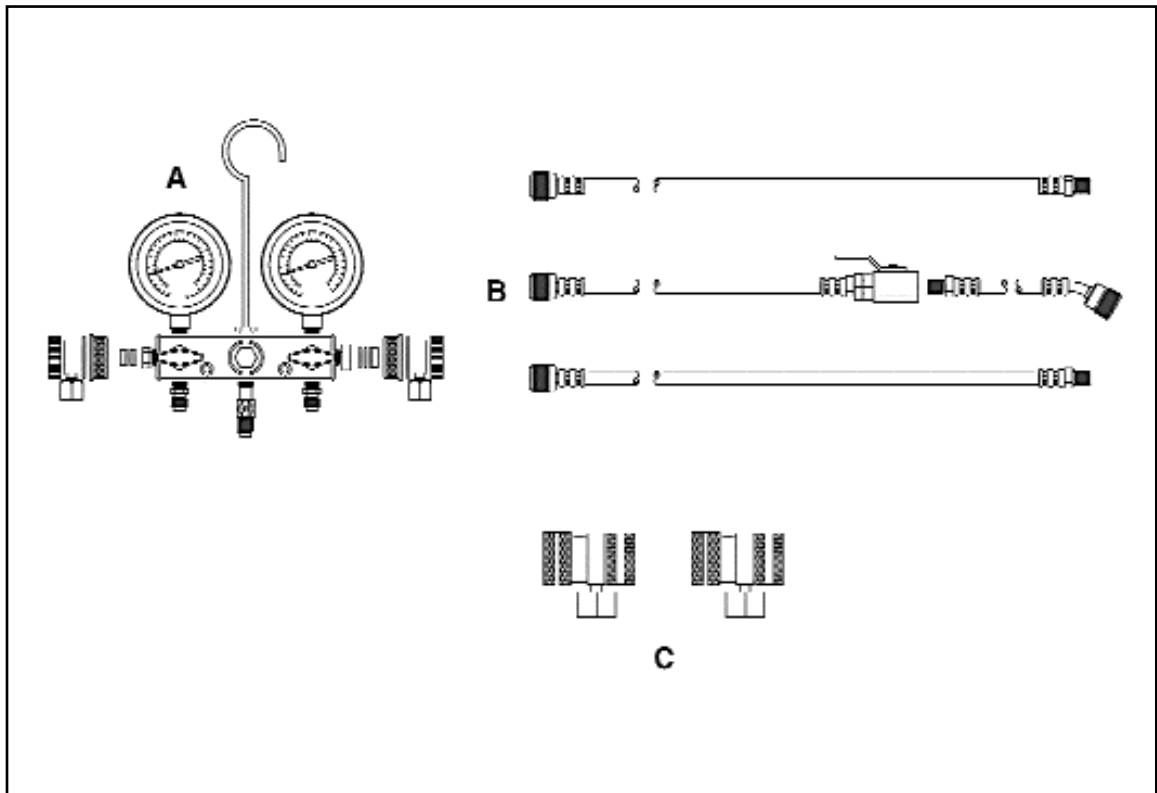

Figure 1-4: R-134a Accessories

A — Gauge Set

High and low pressure gauge manifold set monitors air conditioning system pressures. Right hand valve opens and closes the high-side service hose passage to **ECO**. Left hand valve opens and closes the low-side service hose passage to **ECO**.

B — Service Hoses

Red, blue and yellow hoses for connecting gauge set to vehicle and **ECO**. For additional information refer to *Chapter 2—Connecting Service Hoses to ECO* and *Chapter 2—Connecting Service Hoses to Vehicle*.

C — Shut-off Adaptors

Connects to high-side and low-side service ports of vehicle.

Specifications

General

Power

EEAC107A and EEAC108A
120 VAC, 50/60 Hz, 4 amps

Shipping Weight

120 pounds

Dimensions

| | |
|--------|-----|
| Depth | 12" |
| Height | 45" |
| Width | 18" |

Operating

Operating Temperature Range

50–120°F ambient

Maximum Operating Pressure

High
300 psig
Low
85 psig

Pressure Range

30 inHg–300 psi

Refrigerant Charge Amount

0–25 pounds

Recovery Amount

0–25 pounds

Recovery Rate

1 pound/minute, maximum

Recycled Refrigerant Tank

30 lb. with purge port

Storage

Temperature

-4–158°F

Relative Humidity

Up to 80%, non-condensing

Capacities

Recovery Tank

Up to 25 lbs total

Installation and Operation

Use information in this chapter to:

- Prepare **ECO** for initial use,
- Recover vehicle refrigerant,
- Create a vacuum before recharging, and
- Recharge with recycled refrigerant.

Connecting Service Hoses to **ECO**

Use the following procedure to connect service hoses to **ECO**. Refer to *Figure 2-1*.



- Do not use **ECO** or leak detector equipment if R-12 substitutes are suspected. R-12 refrigerant substitutes may be flammable.
 - Read, understand and follow **Safety Information** in the front of this manual.
 - Refer to *Page 1-4*
- ✓ Always lubricate rubber gaskets and seals at hose connections with fresh refrigerant oil before connecting.
 - ✓ Tighten hose connections finger tight. Use electronic leak detector to insure connections are leak free.
1. Connect one anti-blowback valve, found in unit accessories, to end of yellow service hose with hand valve.
 2. Attach end of yellow hose without hand valve to center port of manifold gauge assembly.
 3. Attach end of yellow hose with hand valve to port on rear panel.
 4. Attach end of blue hose to low side (left) port of manifold gauge assembly.
 5. Attach end of red hose without hand valve to high side (right) port of manifold gauge assembly.
 6. 134a unit only – connect high (red) and low (blue) couplers to their respective hoses. Rotate coupler knobs fully CCW (closed).

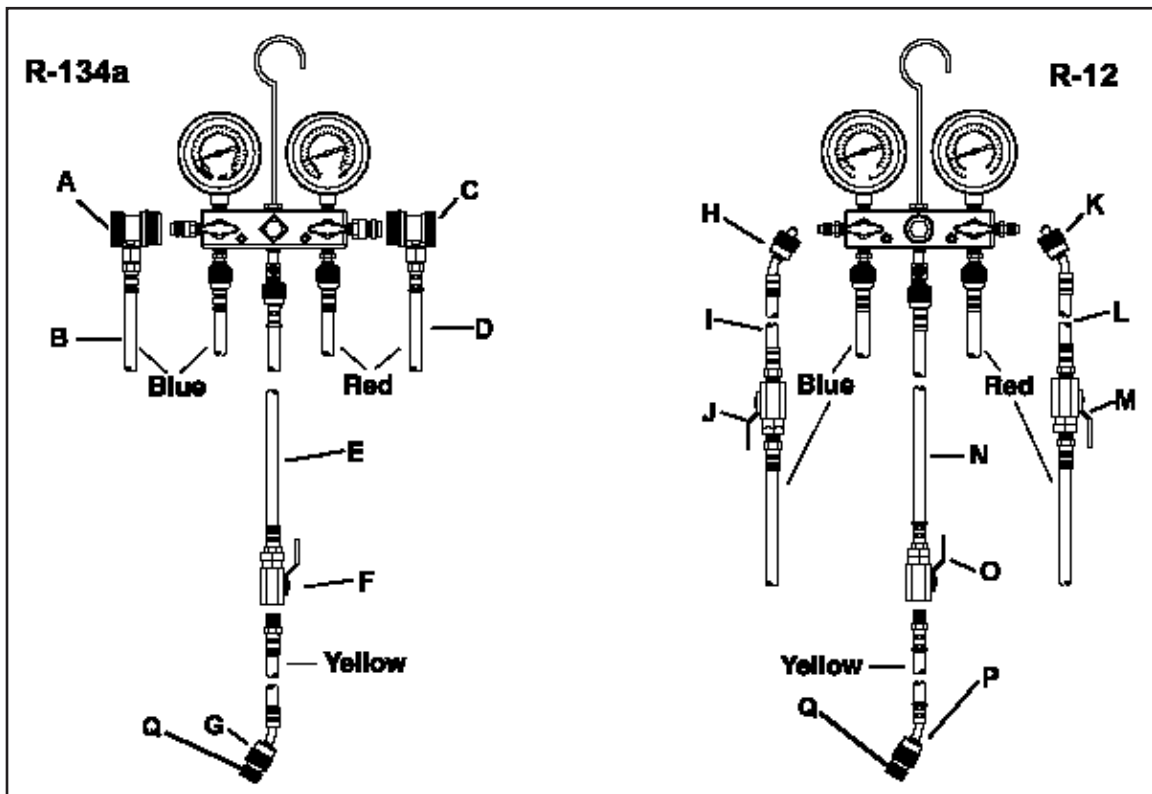

Figure 2-1: Service Hoses and Gauge Sets

R-134a

- A – Low-Side Blue Hose Coupler with valve
- B – Blue Hose
- C – High-Side Red Hose Coupler with valve
- D – Red Hose
- E – Yellow Hose
- F – Hand Valve
- G – Service Port Fitting
- Q – Anti-Blowback Valve

R-12

- H – Low-Side Blue Hose Fitting
- I – Blue Hose
- J – Hand Valve
- K – High-Side Red Hose Fitting
- L – Red Hose
- M – Hand Valve
- N – Yellow Hose
- O – Hand Valve
- P – Service Port Fitting
- Q – Anti-Blowback Valve

Preparing and Installing Recovery Tank

The recovery tank is shipped with a dry air charge. The charge must be vented and the tank evacuated before use. Use the following procedure to evacuate the dry air from the recovery tank and install the tank in *ECO*.



- Do not use any tank with this equipment other than part number EAA0157C00A for R-12 or EAA0158C00A for R-134a. These tanks are D.O.T. certified for refilling. D.O.T. certified tanks are marked "D.O.T. 4BA 350" or "D.O.T. 4BA 400".
- Read, understand and follow *Safety Information* in the front of this manual.



Vent and evacuate tank before first use. Unprepared tank can cause compressor burnout.

- ✓ The recovery tank must have a minimum of 25 inHg vacuum when evacuation is complete. If there is not 25 inHg vacuum, check connections and repeat the procedure.

Tank Preparation

Follow this procedure to install a new recovery tank in *ECO*. New tanks are charged with dry air which must be vented before using tank.



- Wear safety goggles, user and bystander.
- Cover blue hand valve port with shop towel to help prevent debris from becoming projectile.

1. Vent dry air by slowly opening blue hand valve on tank.
2. Gently set tank on scale with hand valves up.

Installation and Operation

3. Place elastic strap around tank so that bottom of strap is 2" above tank center weld.
4. Slide temperature probe, extending from the cabinet, between tank and strap.
5. Connect end of blue service hose leading from bottom of manifold gauge assembly to blue (liquid) tank port.
 - ✓ For model EEAC108A for R134a, install supplied tank adapter, part number 1-15080, between tank valve and blue hose.
6. Open blue (liquid) tank valve, turn fully counterclockwise.
7. Identify red hose leading from bottom of unit. Connect hose end with anti-blowback valve to red (vapor) tank port.
8. Close red (vapor) tank valve, turn fully clockwise.
9. Identify yellow hose leading from bottom of unit. Connect hose end with anti-blowback valve to tank purge port. Rotate tank so yellow hose goes straight up into cabinet.
10. Close hand valve on red service hose.
11. Open the following:
 - Yellow service hose hand valve,
 - Blue service hose hand valve, or coupler (CW)
 - High side manifold hand valve, and
 - Low side low manifold hand valve.
12. Turn compressor switch OFF.
13. Turn vacuum/recycle valve OFF.
14. Connect power cord to wall outlet having correct voltage for unit. For additional information refer to *Chapter 2—Specifications*.
UNIT ON indicator illuminates.
15. Turn compressor switch ON.
COMPRESSOR ON indicator illuminates and compressor activates.
16. Turn vacuum/recycle valve to VACUUM.
Low side manifold gauge shows vacuum increasing.
17. Monitor low side manifold gauge until a minimum of 25 inches of mercury is reached.
18. Turn vacuum/recycle valve OFF.

19. Turn compressor switch OFF.
COMPRESSOR ON indicator goes out and compressor stops running.
20. Close the following:
 - Blue (liquid) tank hand valve, and
 - Blue service hose hand valve, or coupler (CCW).
21. Remove blue service hose from tank. Remove tank adapter 1-15080 if used.
22. Open red (vapor) valve on recovery tank.
23. Connect blue service hose from manifold gauge assembly to tank of virgin refrigerant.
 - ✓ For model EEAC108A for R134a, install supplied tank adapter between tank valve and blue hose.
24. Open the:
 - Virgin tank valve,
 - Blue service hose hand valve, or coupler (CW)
 - Blue manifold hand valve, and
25. Turn compressor switch ON.
COMPRESSOR ON indicator illuminates and compressor activates.
26. Turn vacuum/recycle valve to RECYCLE.
Refrigerant flows from virgin tank through **ECO** and into prepared recovery tank.
 - ✓ Press mode button until *Tare Weight* is displayed. Monitor weight on LCD display until desired amount of virgin refrigerant has been transferred. Refer to *Tank Full/Empty* in this Chapter.
27. When desired amount of refrigerant has been transferred into recovery tank, close:
 - Virgin tank hand valve, and
28. Allow recycler to run until 15”Hg vacuum is reached. Then close:
 - Blue service hose valve or coupler.
29. Turn vacuum/recycle valve OFF.
30. Turn compressor switch OFF.
31. Compare recovery tank pressure/temperature relationship with the chart and bleed off any non-condensables (air) by pressing PURGE button. Refer to *Purging non-condensable gas* in this chapter.

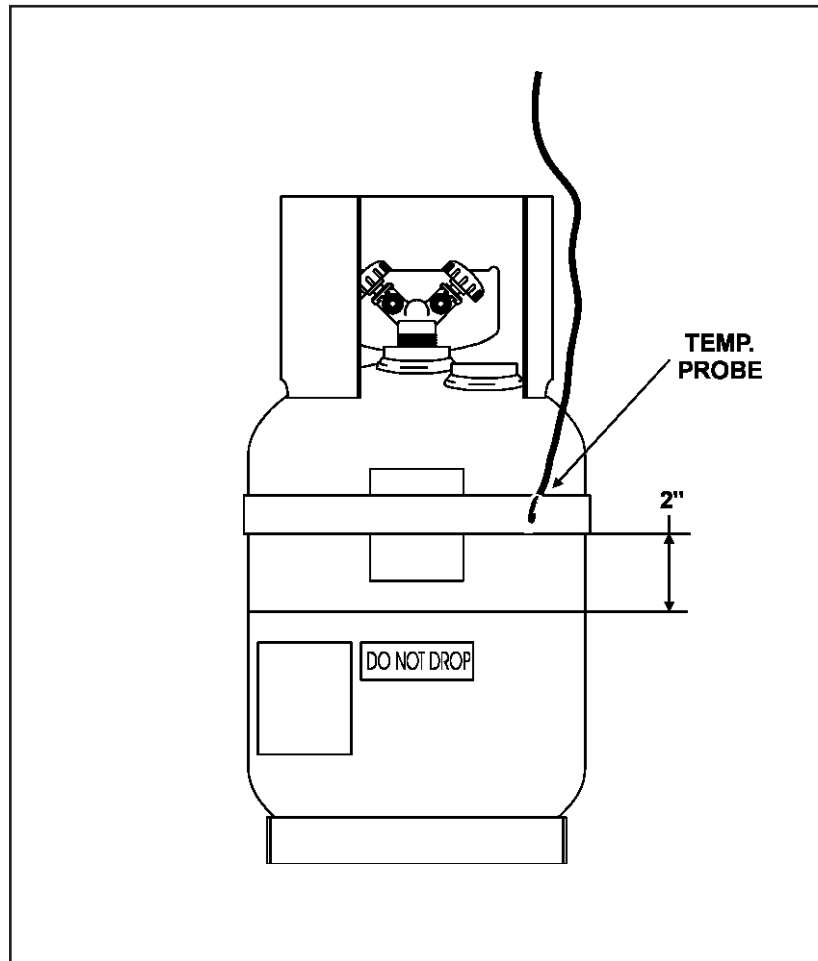

Figure 2-2: Recovery Tank and Temperature Probe

- ✓ Use only the 30 pound capacity recovery tank supplied with **ECO** or one indicated by the warning label on the back of the unit. Using any other type or capacity tank could create the danger of explosion and potential for personal injury. Inaccurate refrigerant amount may display if the correct tank is not used.

Operation

This section contains:

- Procedures for connecting service hoses to the vehicle, and
- Procedures to:
 - Recycle vehicle refrigerant,
 - Create a vacuum in the A/C system before recharging, and
 - Recharge the A/C system with recycled refrigerant.

After performing all installation procedures, follow these recommended vehicle service procedures before using **ECO** for A/C work.

Preliminary Checks

Successful use of **ECO** depends on several external factors. The following information explains these.

Precondition Vehicle

Refrigerant in vehicle A/C system is recovered more completely when components are warm.

To efficiently recover refrigerant, the vehicle should be at normal operating temperature. Run engine until normal operating temperature is reached, with

- A/C system off, and
- Hood closed.

- ✓ Sometimes a small amount of refrigerant is left in the vehicle A/C system that is not practical to recover. If recovery time is too short or if vehicle components are cold, this parasitic refrigerant can expand during a vacuum hold test, reducing the vacuum in vehicle A/C system. This could be interpreted as a leak, yet none exists.

Allow Adequate Evacuation Time

Evacuate the vehicle system for a minimum of 30 minutes. This helps ensure vehicle A/C system is free of non-condensable gas (mostly air) and moisture.

Follow Vehicle Manufacturer's A/C Service Procedures

When charging, a slow charge condition may occur due to pressure equalization between **ECO** and vehicle A/C system. Finish charging by:

- Closing high-side manifold valve,
- Starting engine, and
- Turning A/C system ON.

- ✓ It is the technician's responsibility to be familiar with vehicle manufacturer recommended service procedures.

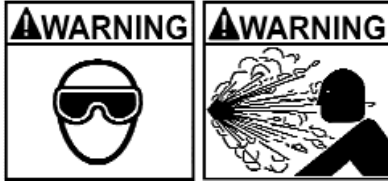

Keep the service hoses away from moving or hot engine parts. Service hoses can not withstand high temperatures or severe mechanical stress.

IMPORTANT

- Close tank valves when not using ECO. Leaving tank valves open may result in refrigerant loss from tank.
- Do not use *ECO* outside of the following limits:
 - Warmer than 49°C (120°F),
 - Colder than 10°C (50°F), and or
 - Relative humidity greater than 80%.
- Stabilize *ECO* to a moderate temperature and inspect for abnormalities.
- Contact your *Snap-on/Sun* representative before operating if unsure of condition.
- Operating *ECO* with the following conditions may reduce its functionality:
 - Visible evidence of damage,
 - Has been subjected to prolonged storage under unfavorable conditions, or
 - Has been subjected to severe transportation stresses.

Connecting Service Hoses to Vehicle

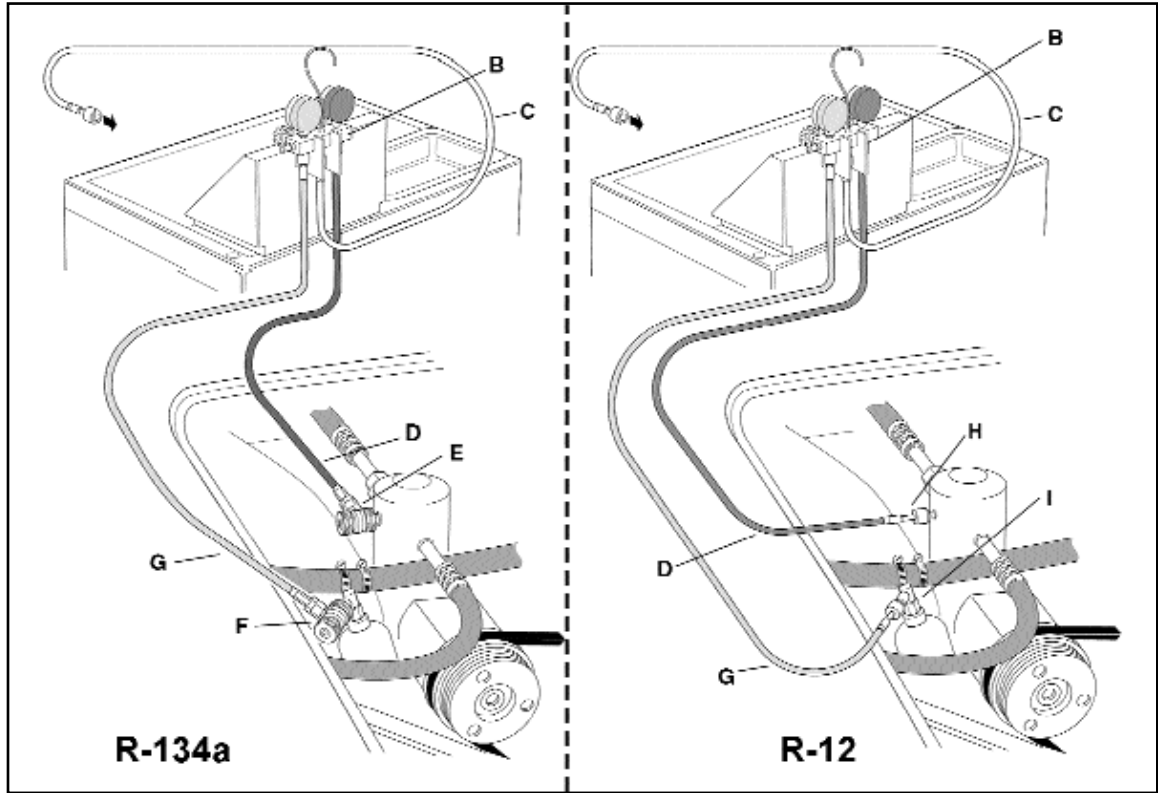

Figure 2-3: Service Hose Connections to Vehicle

- B – Manifold Gauge Set*
- C – Yellow Hose*
- D – Blue Hose*
- E – Low-Side Blue Hose Coupler*
- F – High-Side Red Hose Coupler*
- G – Red Hose*
- H – Low-Side Blue Hose Fitting*
- I – High-Side Red Hose Fitting*

Follow this procedure to connect the service hoses to the vehicle.

1. Connect red high-side hose with service fitting adaptor, if applicable, from manifold gauge set to high-side service port on vehicle.
 2. Connect blue low-side hose with service fitting adaptor, if applicable, from manifold gauge set to low-side service port on vehicle.
- ✓ If the vehicle has more than one low-side service port, use the service port closest to the evaporator.

3. Open hose hand valves or service couplers.
 - Refer to the vehicle manufacturer's service manual for proper diagnostic procedures and specifications.

Recover/Recycle Refrigerant from Vehicle

- ✓ Be sure vehicle is at operating temperature before recovering refrigerant.
1. Open red (vapor) recovery tank valve.
 2. Connect service hoses to vehicle. For additional information refer to *Connecting Service Hoses to Vehicle* in this chapter.
 3. Open:
 - High (red) side service hose valve or coupler
 - Low (blue) side service hose valve or coupler
 - High (red) manifold hand valve
 - Low (blue) manifold hand valve
 4. Turn compressor ON.
COMPRESSOR ON indicator illuminates and compressor activates.
 5. Turn vacuum/recycle valve to RECYCLE.
Refrigerant flows from vehicle, through **ECO**, and into recovery tank.

As refrigerant is recovered, the low side manifold gauge shows increasing vacuum. Continue recovering until low side manifold gauge indicates 15 inHg.
 6. Close:
 - High side manifold hand valve, and
 - Low side manifold hand valve.
 7. Turn vacuum/recycle valve to OFF.
 8. Turn compressor switch OFF.
 9. Monitor low side manifold pressure gauge for about 2 minutes.
 - No change indicates recovery is complete. Continue with system repair and/or evacuation.
 - Pressure increase indicates more recovery time required or vehicle A/C system has leak. Repeat steps 3 through 9.

If gauge reading still increases, add partial charge to system and leak test with electronic leak detector to find leak.

10. Close red and blue service hose hand valves or couplers.
11. Purge noncondensables.
 - ✓ For additional information refer to *Purging Non-condensable gas* in this chapter.

Compare the recovery tank pressure/temperature relationship with the chart and bleed off any non-condensables (air) by pressing the Purge valve button.
12. Remove graduated cup from lower shelf and hold it under the Oil Drain valve.
13. Slowly open oil drain valve. Any accumulated oil expels into cup.
14. Close valve immediately when all oil is expelled. Amount indicated on cup is amount to add back into vehicle system when recharging.
 - ✓ Discard refrigerant oil in accordance with laws in your area.

Purging Non-condensable Gas

- ✓ Be sure to purge non-condensable gases immediately after each recovery and before each charge.
1. Using the pressure/temperature chart located on the front panel of the unit, find the temperature that is the same as the reading on the temperature gauge. Next to the temperature is a pressure reading. That pressure reading should be what the pressure gauge indicates.
 2. If the pressure is higher, press the purge button on the front of the unit until the pressure on the gauge is the same as what is on the chart.
 3. Wait a minute and monitor temperature and pressure again. If they do not correspond to the chart, purge again until they do.

Evacuating A/C System

Use this procedure to remove air and moisture from vehicle A/C system.

- ✓ If gauges indicate pressure, recover refrigerant from service hoses before proceeding. Refer to *Evacuating Service Hoses* in this Chapter.
1. Open the following:
 - Red service hose hand valve or coupler,
 - Blue service hose hand valve or coupler,
 - High side manifold hand valve, and
 - Low side manifold hand valve.
 2. Turn Compressor switch ON.
 3. Turn vacuum/recycle valve to VACUUM.
Low side manifold gauge shows vacuum increasing.
- ✓ Follow manufacturer recommendations for evacuation time, usually at least 30 minutes.
4. Close manifold hand valves when desired vacuum and duration have been reached.
 5. Turn Vacuum/Recycle valve OFF.
 6. Turn compressor switch OFF.
COMPRESSOR ON indicator goes out and compressor stops running.
 7. Monitor low side pressure for 5 minutes.
Any rise in vacuum indicates a leak in vehicle system.
- ✓ If source of leak cannot be determined, partially charge system and perform leak test using electronic leak detector.
8. When leak is identified, repeat Recover/Recycle procedure, repair leak and attempt Evacuation procedure again.

Evacuation is complete.

Charging A/C System

1. Close the yellow service hose hand valve.
2. Remove yellow hose with anti-blowback valve from the service port and connect it to blue (liquid) recovery tank port.
3. Open blue (liquid) tank valve.
4. Press Mode Button so a tare weight of 0.0 is displayed.
5. Connect service hoses to vehicle. Open hand valves or couplers.
6. Open yellow service hose hand valve. Refrigerant flows from tank into vehicle.
7. Monitor tank weight. When desired charge amount is reached, close yellow service hose hand valve or coupler. Refrigerant flow stops.
 - ✓ If desired charge amount cannot be reached:
 - Close yellow service hose hand valve,
 - Run A/C system,
 - Open yellow service hand valve,
 - Monitor tank weight and close hand valve when desired charge amount is reached.
8. Close blue (liquid) recovery tank hand valve.
9. Reattach yellow service hose with anti-blowback valve to service port.
10. Monitor high and low side system pressures. Refer to manufacturer specifications for proper operation and diagnosis.

Charge complete.

- ✓ When charging a vehicle after evacuation, allow for the capacity of the hoses. Each hose holds approximately two ounces, so the charge amount should be increased by two ounces for each hose used.
 - If there is not enough refrigerant in the tank to charge, refer to *Adding Refrigerant to ECO* in this chapter.

Displaying Refrigerant Amount

Use this procedure to determine the amount of refrigerant in recovery tank and amount able to be charged.

1. Press Mode button until Gross weight displays on LCD.
2. This is the total weight of the recovery tank plus recycled refrigerant. The tank itself weighs approximately 16 lbs. approximately 3 lbs of refrigerant is needed to meet the quill tube in the tank. This makes the "Tank Empty" point 19 lbs. Any refrigerant over this amount is usable for charging.

Tank Full/Empty

Messages display when the recovery tank is full or empty.

- ✓ The unit may be used to evacuate or charge an A/C system when recovery tank is full.
- ✓ The unit may be used to recycle or evacuate an A/C system when recovery tank is empty.
- ✓ "Tank Empty" is displayed when the Gross weight of the recovery tank is approximately less than 19 lbs.
- ✓ "Tank Full" is displayed when the Gross weight of the recovery tank is 40 lbs.

Removing Recovery Tank

1. Close both valves on recovery tank.
2. Disconnect hoses from recovery tank.
3. Remove elastic band and temperature probe from tank.
4. Gently remove tank from scale.

Evacuating Service Hoses

Evacuate the service hoses before removing them from the manifold gauge assembly and whenever contamination is suspected. Service hoses are not connected to a vehicle during this procedure.

1. Close red and blue service hose hand valves.
2. Open manifold valves.

3. Plug power cord into properly grounded supply line. See ID plate for proper supply voltage.
4. Turn compressor switch on.
5. Turn vacuum/recycle valve to RECYCLE.
6. Monitor manifold gauges.

Hose evacuation is complete when 15"Hg of vacuum is reached.

7. Turn vacuum/recycle valve to OFF.
8. Turn compressor switch to OFF.

Hose evacuation is complete.

Adding Refrigerant to *ECO*

Follow this procedure to add virgin refrigerant to *ECO*.

- ✓ Recovery tank should have at least six pounds of refrigerant or charge procedure may not be completed.
1. Refer to *Preparing and Installing Recovery Tank* in this chapter.
 2. Open red (vapor) valve on recovery tank.
 3. Connect blue service hose from manifold gauge assembly to tank of virgin refrigerant.
 - ✓ For model EEAC108A for R134a, install supplied tank adapter between tank valve and blue hose. Virgin tank should be upright (valve up).
 4. Open the:
 - Virgin tank valve,
 - Blue service hose hand valve,
 - Blue manifold hand valve, and
 5. Turn compressor switch ON.
COMPRESSOR ON indicator illuminates and compressor activates.
 6. Turn vacuum/recycle valve to RECYCLE.
Refrigerant flows from virgin tank through *ECO* and into prepared recovery tank.
 - ✓ Monitor weight on LCD display until desired amount of virgin refrigerant has been transferred. Refer to *Tank Full/Empty* in this Chapter.

7. When desired amount of refrigerant has been transferred into recovery tank, close:
 - Virgin tank hand valve, and
8. Allow recycler to run until 15”Hg vacuum is reached. Then close:
 - Blue service hose valve.
9. Turn vacuum/recycle valve OFF.
10. Turn compressor switch OFF.
 - ✓ Compare recovery tank pressure/temperature relationship with the chart and bleed off any non-condensables (air) by pressing PURGE button. Refer to *Purging Non-condensable Gas* in this chapter.

Maintenance

Use this chapter to maintain **ECO**:

- Master filter,
- Pump, and
- When stored for prolonged periods.

Troubleshooting information and a list of parts and accessories are also included.

Equipment Tips

- A stable scale weight reading, with the refrigerant not moving around in the recovery tank, is needed at the beginning and end of a recycle or charge program. Do not lean on or move the unit at these times.
- Never attempt to change the recovery tank during unit operation.
- Always evacuate service hoses before disconnecting from **ECO** or manifold gauge set. For additional information refer to *Chapter 2–Evacuating Service Hoses*.
- Never drop a recovery tank onto scale. This may damage scale assembly.
- Always oil seals before connection to any tank, filter or fitting. A leaky connection or no-flow condition may result if connection is assembled dry.
- Always close both tank valves—clockwise—on the recovery tank when **ECO** is not in use.
- Non-condensable gasses must be purged from the recovery tank. For additional information refer to *Chapter 2–Purging Non-condensable Gas*.

Master Filter

Change the master filter when the moisture indicator is violet or when the hour meter has accumulated **20** additional hours since the last master filter change. Any hours already showing on the meter when unit is originally un-boxed and setup should be noted on the next page as the first entry. These should not be included in the first filter change interval, but considered the starting point. Refer to the Moisture Indicator Chart below. Complete the *Master Filter Maintenance Schedule* on the following page to track when to change master filter.

Moisture Indicator

| Moisture Indicator Chart | | | | |
|-------------------------------------|--------|-------------|------------|------------|
| Indicator Color | Model | Temperature | | |
| | | 75°F/24°C | 100°F/38°C | 125°F/52°C |
| Purple <i>Very Dry</i> | R-12 | 1.4 ppm | 2.5 ppm | 4 ppm |
| | R-134a | 20 ppm | 35 ppm | 60 ppm |
| Violet <i>Dry/Caution</i> | R-12 | 5 ppm | 9 ppm | 15 ppm |
| | R-134a | 35 ppm | 55 ppm | 85 ppm |
| Pink <i>Caution/Wet</i> | R-12 | 15 ppm | 27 ppm | 45 ppm |
| | R-134a | 90 ppm | 120 ppm | 150 ppm |
| Orange <i>Very Wet</i> | R-12 | 25 ppm | 43 ppm | 70 ppm |
| | R-134a | 130 ppm | 160 ppm | 190 ppm |

Figure 3-1: Moisture Indicator Chart

Changing the Master Filter

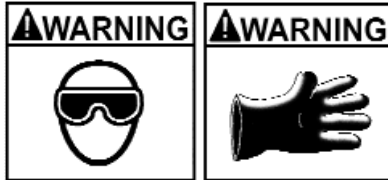

Use the procedure in this section to change the master filter.

- **Wear safety goggles and protective gloves, user and bystander. If any refrigerant gets into eyes, flush with water and seek a doctor's aid immediately, even though irritation may cease.**
- **Do not remove master filter while under pressure. Perform maintenance procedure for removing master filter in this section.**
- **Prevent refrigerant from contacting the skin.**
- **Read, understand and follow *Safety Information* in the front of this manual.**

1. Evacuate service hoses. For additional information refer to *Chapter 2-Evacuating Service Hoses*.
2. Remove power cord from wall outlet.
3. Release hook and loop strap securing master filter.

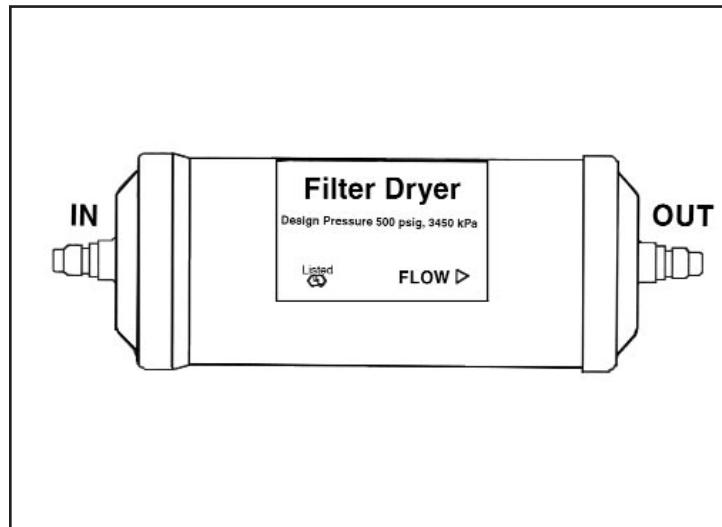

Figure 3-3: Master Filter

4. Unscrew two hose fittings from master filter.
5. Remove master filter.
 - ✓ Dispose of the filter according to local, state and federal regulations that apply in your area.
6. Install new master filter, matching direction of FLOW on filter with flow decal on cabinet.
7. Attach fittings hand tight.
8. Mount master filter securely by tightening hook and loop strap.

8. Check for leaks.

Pump

The oil in the pump assembly must be changed quarterly to prolong pump life. The optional oil change kit is recommended. For additional information refer to *Replacement Parts* in this chapter. All parts necessary to change the pump oil are included in this kit.

Maintaining the Pump

1. Perform a Recycle on the service hoses, if necessary. For additional information refer to *Chapter 2—Evacuating Service Hoses*.
2. Unplug **ECO** from electrical outlet.
3. Remove screws holding rear cover.
4. Remove rear cover.

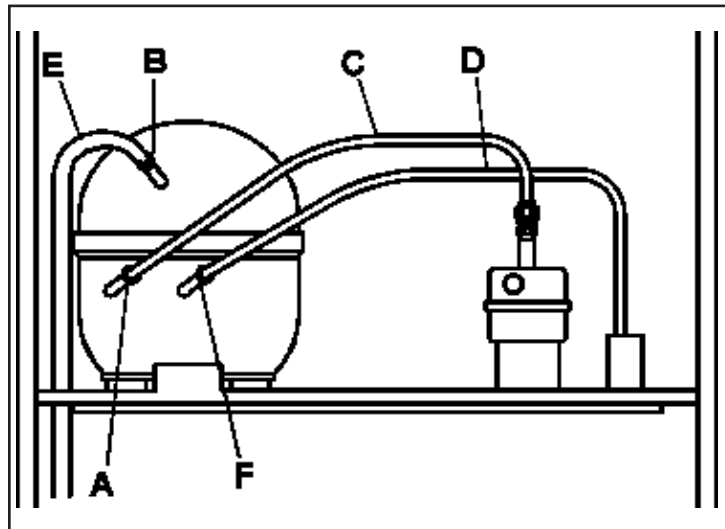
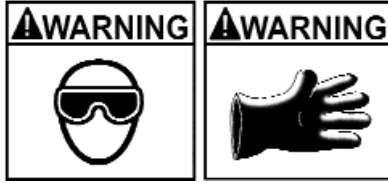

Figure 3-4: Pump

- A – Outlet Line Connection at Pump
- B – Input Line Connection at Pump
- C – Outlet Line (Tube)
- D – Process Line (Tube)
- E – Input Line (Hose)
- F – Process Line Connection at Pump



- Wear safety goggles and protective gloves, user and bystander.
- Read, understand and follow *Safety Information* in the front of this manual.

5. Disconnect blue hose (E) from input line pump connection (B).
6. Disconnect process line connection (F) and move slightly from pump.
 - ✓ Discard the O-rings from hose tube ends.
7. Remove the recovery tank. Refer to *Chapter 2-Removing Recovery Tank*.
8. Tilt unit onto it's back and over an oil drain pan. Approximately 9 oz. of oil should be recovered.
9. Tilt unit to normal upright position. If approximately 9 oz. of oil is not recovered, repeat steps 8 and 9.
10. Use plastic bottle supplied with oil change kit to pour 9.3 oz (275 cc) of 3GS compressor oil, part number 681-0179-2, into input port of pump (top port).
11. Install new O-rings on ends of the tubing and hose assemblies.
12. Place a small amount of compressor oil on O-rings and reinstall tubing assemblies. Torque to 65 in. lbs..
13. Replace rear cover.

Storing *ECO*

Follow this procedure when storing *ECO* for prolonged periods, (3 months or more).

1. Change pump oil using *Maintaining the Pump* procedure in this chapter.
2. Close both hand valves on recovery tank.
3. Close service hose, coupling and manifold valves.

Troubleshooting

| Symptom | Possible Cause | Remedy |
|--|---|--|
| Machine does not turn on | • Power cord not plugged in | – Plug in cord |
| | • No power in AC outlet | – Check power source |
| Refrigerant not being removed from vehicle | • Hand valves not open | – Open hand valves |
| | • Recovery tank full. | – Change tank or Charge refrigerant |
| Excessive purging of non-condensables | • Fitting(s) not properly connected to master filter | – Tighten fitting(s) finger tight |
| | • Leaky service hose or adaptor connection drawing in air | – Tighten fittings or replace seals in finger tight fittings |
| Does not charge | • Blue hand valve on recovery tank not open | – Open blue hand valve |
| | • Fitting not properly connected to recovery tank | – Tighten fitting finger tight |
| | • No refrigerant in tank | – Fill tank with refrigerant |
| Machine does not draw a vacuum | • Loose hose connection | – Tighten loose hose connections |
| | • Oil drain valve open | – Close oil drain valve |
| Hissing noise from oil separator during recycle and/or vacuum mode | • Oil drain valve open | – Close oil drain valve |
| Refrigerant losses from tank on scale over time | • Leaky hand valve(s) on tank | – Make sure hand valves are either open completely (CCW) or closed completely (CW) and leak test |
| | • Leaky fitting(s) | – Oil seal with refrigerant oil and reconnect OR, replace fitting, oil seal and reconnect |
| Long recycle times | • System being recycled is cold and has components that hold a substantial amount of liquid refrigerant | – Heat A/C system by running engine with A/C OFF and keep hood closed as much as practical to hold in heat |

Replacement Parts

Model EEAC107A for R-12

| Part Number | Description |
|--------------------|------------------------------------|
| 0647-0196-01 | GM Adaptor, high-side |
| 0647-0197-01 | GM/Ford Adaptor, Quick Disconnect |
| 0647-0199-01 | Large GM Adaptor, Quick Disconnect |
| 0647-0200-01 | Ford Adaptor |
| EAA0157C00A | Recovery Tank, 30 pound |
| EAH0013C00A | Gauge Assembly with hoses—USA |
| 4719-0055-01 | R-12 Anti-blowback Valve |

Model EEAC108A for R-134a

| Part Number | Description |
|--------------------|--------------------------------------|
| 0647-0287-08 | Service Fitting, low-side |
| 0647-0287-07 | Service Fitting, high-side |
| EAA0158C00A | Recovery Tank, 30 pound |
| EAH0014C01A | Gauge Assembly with hoses—USA, Japan |
| 4719-0055-02 | 134a Anti-blowback Valve |

Optional Accessories

Model EEAC107A for R-12

| | |
|-------------------|-------------------------------------|
| EAH0013C21A | Gauge Assembly with hoses—Europe |
| EAH0013C22A | Gauge Assembly with hoses—Japan |
| 0647-281-01 | GM Adaptor for A, F, U and W Bodies |
| ACT-111B | 2 oz. Oil Charge Kit for R-12 |

Model EEAC108A for R-134a

| | |
|--------------------|--------------------------------------|
| EAK0027C00AS | Vehicle Adaptor Repair Kit (O-rings) |
| EAH0014C12A | Gauge Assembly with hoses—Europe |
| 1-15080 | Low Side Adapter Fitting |
| 1091-0301-01 | 2 oz. Oil Charge Kit for 134a |

Both Models

| | |
|--------------------|------------------|
| EEAC107ACV | Protective Cover |
| EAK0030C03AB | Master Drier Kit |
| EAK0029C00AB | Oil Change Kit |

For service or to order replacement parts or optional accessories, contact your **Snap-on/Sun** Representative or call 1-800-CALL-**SUN** (1-800-225-5786).

