

**WHEELTRONIC**  **LTD.**

# INSTALLATION and OPERATION MANUAL



**4-POST**  
**MODEL 10424AF**  
**(20" RUNWAYS)**  
**10,000 LB.**

---

**READ and SAVE THIS  
INSTRUCTION MANUAL**

**AUG 2007 REV.A 6-1586**

**WHEELTRONIC**  **LTD.**

6500 Millcreek Drive  
Mississauga, Ontario, Canada  
L5N 2W6  
Phone: 1-800-268-7959  
Fax: 905-826-7800

## THE FOLLOWING APPLIES TO ALL LIFTS

### IMPORTANT SAFETY INSTRUCTIONS

1. When using this lift, basic safety precautions should always be followed, including the following:
2. Read all instructions in this manual and on the lift.
3. Inspect lift daily. Do not operate if it malfunctions or problems have been encountered.
4. Never attempt to overload the lift. The manufacturer's rated capacity is shown on the identification label on the power side column. Do not override the operating controls or the warranty will be void.
5. Only trained and authorized personnel should operate the lift. Do not allow customers or bystanders to operate the lift or be in the lift area.
6. **Caution! Never work under the lift unless the mechanical safety locks are engaged.**
7. Always keep the lift area free of obstruction and debris. Grease and oil spills should always be cleaned up immediately.
8. Never raise vehicle with passengers inside.
9. Before lowering check area for any obstructions
10. To protect against the risk of fire, do not operate lift in the vicinity of open containers of flammable liquids.
11. Adequate ventilation should be provided when working on internal combustion engines.

### SAVE THESE INSTRUCTIONS

## TABLE OF CONTENTS

1. SPECIFICATIONS	4
2. TOOLS REQUIRED	4
3. CONTENTS	5
4. INSTALLATION INSTRUCTIONS	7
- Chalk Line Layout	7
- Front and Rear Crossmember Identification	9
- Sheaves Installation	10
- Cable Installation	11
- Power Pack Installation	13
- Electrical Connections	14
- Hydraulic Installation	15
- Air Installation	15
- Leveling Procedure Cables	16
- Anchor Installation	18
- Leveling Procedure Safety Ladders	19
5. SAFETY AND OPERATING INSTRUCTIONS	20
6. LIFT MAINTENANCE GUIDELINES	21
7. PARTS MANUAL	23
- Lift Assembly	24
- Lift Part List	25
- Hydraulic and Air Kits	27
- Hydraulic and Air Kits Part List	28
- Cable Routing Diagram	29
- Cable Routing Part List	30
- Power Pack	31
- Power Pack Part List	32

## 1. GENERAL SPECIFICATIONS

Maximum Capacity:	10000 lbs.	4536 kg
Overall Length:	224"	5690mm
Overall Width:	125"	3175mm
Down Position Height:	9.5"	241mm
Maximum Lifting Height:	71"	1803mm
Maximum Wheel Base:	144"	3658mm
Power Requirements:	230 Volts AC, 1Ph., 20 Amp, 60Hz.	
Shipping Weight:	3750 lbs.	1705kg

### **CHECK CONTENTS OF ACCESSORY BOX WITH THE PACKING LIST ENCLOSED**

## 2. TOOLS REQUIRED FOR INSTALLATION

ROTARY HAMMER DRILL  
3/4" CONCRETE DRILL BIT  
SOCKET FOR TIGHTENING ANCHORS  
4' LEVEL  
HAMMER (for anchor installation)  
PRY BAR (for shim installation)  
CHALK LINE (lift location)  
FISH (mechanics wire to feed cable through crossmember assembly)  
TAPE MEASURE  
ELECTRICAL TAPE  
STEP LADDER (adjusting cables and/or safety ladder in posts)  
SIDE CUTTERS (for cutting shipping straps)  
BAR (4' long)  
4 WORK STANDS (set up)  
STANDARD SOCKETS AND WRENCHES

**It is the user's responsibility to provide a satisfactory installation area for the lift. Lifts should only be installed on level concrete floors with a minimum thickness of five (5) inches or 130 mm. Concrete must have a minimum strength of 4000 psi or 30 MPa and should be aged thirty (30) days prior to installation. Please consult the architect, contractor or engineer if doubt exists as to the strength and feasibility of the floor to enable proper lift installation and operation.**

**It is the user's responsibility to provide all wiring for electrical hook-up prior to installation and to insure that the electrical installation conforms to local building codes. Where required, it is the user's responsibility to provide an electrical isolation switch located in close proximity to the lift that will enable emergency stop capability and isolate electrical power from the lift for any servicing requirements.**

### **3. CONTENTS**

The lift is packaged to prevent any damage that may occur during shipping. The two deck assemblies and crossmembers are packaged together with the accessory boxes strapped to them.

#### **Main Structural Components:**

- 1 - Left Side Deck Assembly (complete with hydraulic cylinder)
- 1 - Right Side Deck Assembly
- 1 - Front Crossmember Assembly (with air cylinder release locks and sheaves)
- 1 - Rear Crossmember Assembly (with air cylinder release locks and sheaves)

#### **Accessory Box Components**

##### **Box 1 Contents:**

- 1 - Power Post (with safety ladder)
- 3 - Post (with safety ladder)

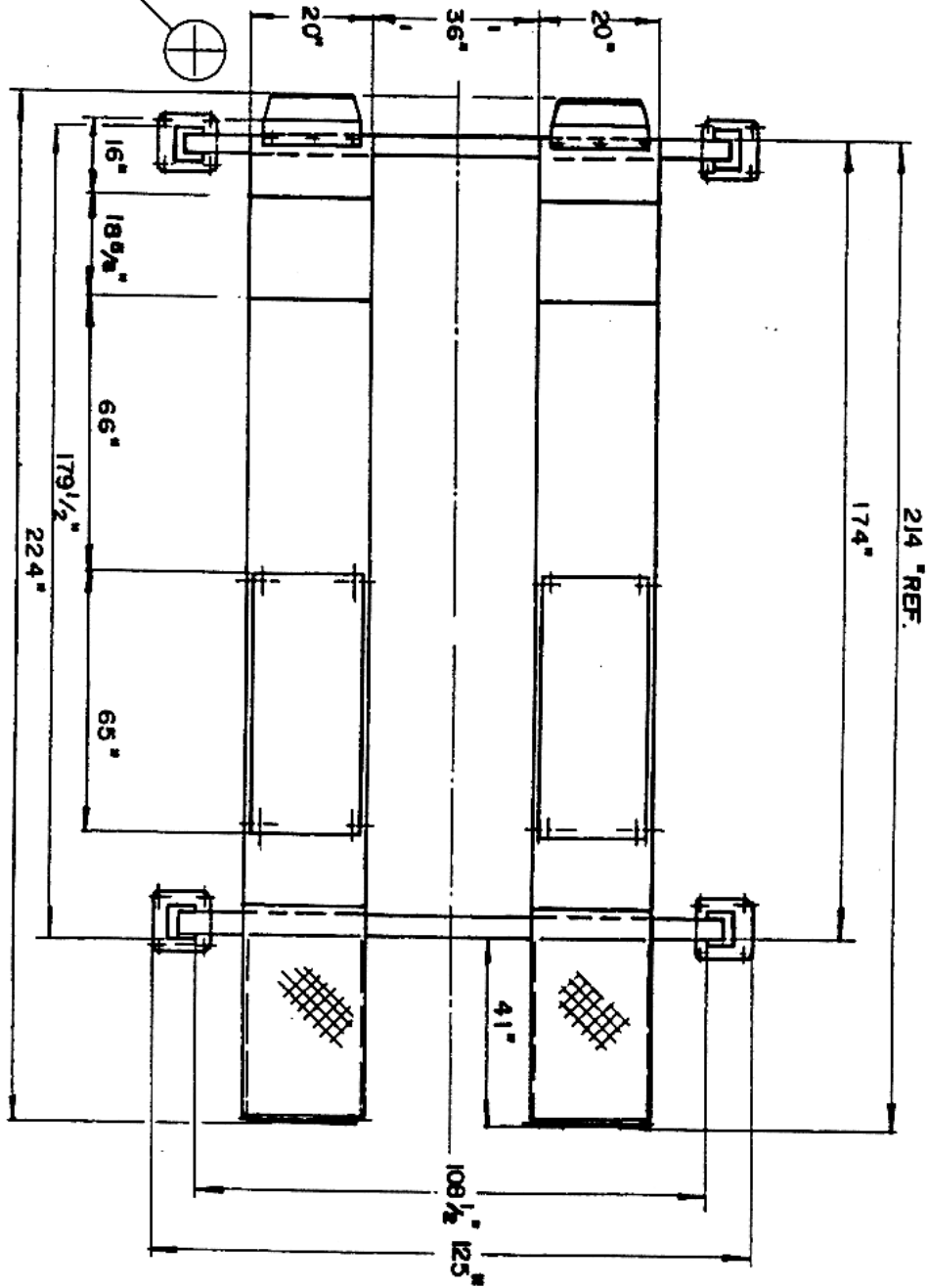
##### **Box 2 Contents:**

- 1 - Power Pack Assembly complete with Flow Control
- 2 - Approach Ramps
- 7 - Sheave Assemblies
- 1 - Set of Cables (set contains 4 cables with nuts and spacers)
- 7 - Sheave Spacers (different sizes)
- 2 - Front Wheel Stops
- 2 - Ramp Pins
- 4 - Deck Sheave Pins
- 1 - Air Kit (with 1/4" and 3/8" polytube and fittings)
- 1 - Hydraulic Hose (with fittings)
- 1 - Hose Guard
- 4 - Sheave Covers
- 3 - Cable Tie (for attachment of hydraulic hose to cylinder)
- 2 - Recoiled Air Hoses 12' long
- 1 - Coupler 1/4" NPT
- 1 - Package of Hardware (with its own packaging list)
- 1 - Owner's manual
- 1 - ALI manual "Lifting It Right"
- 1 - Automotive Lift Safety Tips
- 1 - Automotive Lift, Operation, Inspection and Maintenance manual

# GENERAL SPECIFICATIONS

## FRONT

POWER PACK  
LEFT SIDE



REAR

#### 4. INSTALLATION INSTRUCTIONS

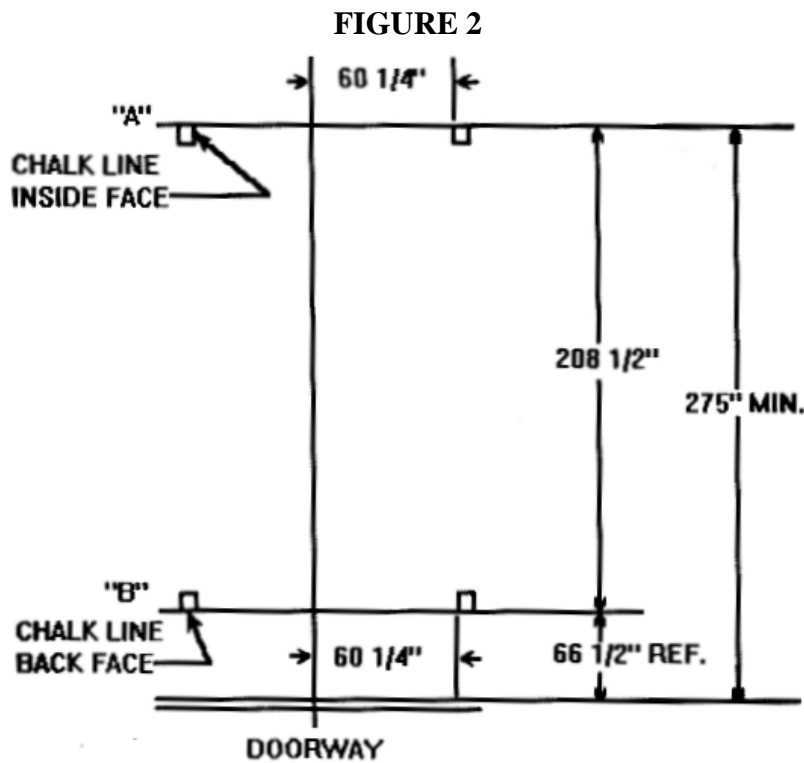
**PLEASE TAKE THE TIME TO READ THESE INSTRUCTIONS COMPLETELY. A QUICK CHECK OF THE CONTENTS OF THE ACCESSORY BOX WOULD ALSO DECREASE THE OVERALL TIME OF THE INSTALLATION.**

1. Gather the tools and materials required for the installation.
2. Select the location best suited for your lift.

**NOTE:** In determining lift area, check for the following:

- Ease of driving a vehicle on and off the lift.
- Overhead obstructions, low ceiling height, overhead doors, overhead heaters, etc.
- Floor obstructions, uneven floor in lift area, floor drains, work benches, electrical wiring in floor, etc.
- An outline matching the dimensions listed below will need to be marked on the floor. Refer to Figure 2 for outline dimensions. Refer to General Lift Specifications for overall lift dimensions. Figure 1.

##### 4.1 CHALK LINE LAYOUT



Refer to Figure 2. Make a chalk line parallel to the doorway at least 235" in from the doorway. This will be the furthest front face of the front post location. Call this line "A". Determine the center of the doorway and bay. Make a centerline to intersect with line "A". Measure from the centerline along line "A" 54 1/4" in both directions. This will be the location of the inside face and front face of the front posts. Measure back from this line "A" 179 1/2". Make a chalk line parallel to line "A". Call this line "B". This will be the location for the back face of the rear posts. Measure from the centerline along line "B" 54 1/4" in both directions. This will be the location of the inside face and back face of the rear posts. Position work stands inside of line "A" and "B" of outline, to support the front and rear of each deck assembly.

### **IMPORTANT**

**NOTE:** To determine the front, rear, left side and right side of the decks check the following:

4. The left deck has the hydraulic cylinder mounted to its underside. The rear of the decks have approach ramp brackets to install the drive on approach ramps. The work steps, attached to the turn plate pocket cutouts will face towards the front outside of the lift.
5. Position decks on work stands.

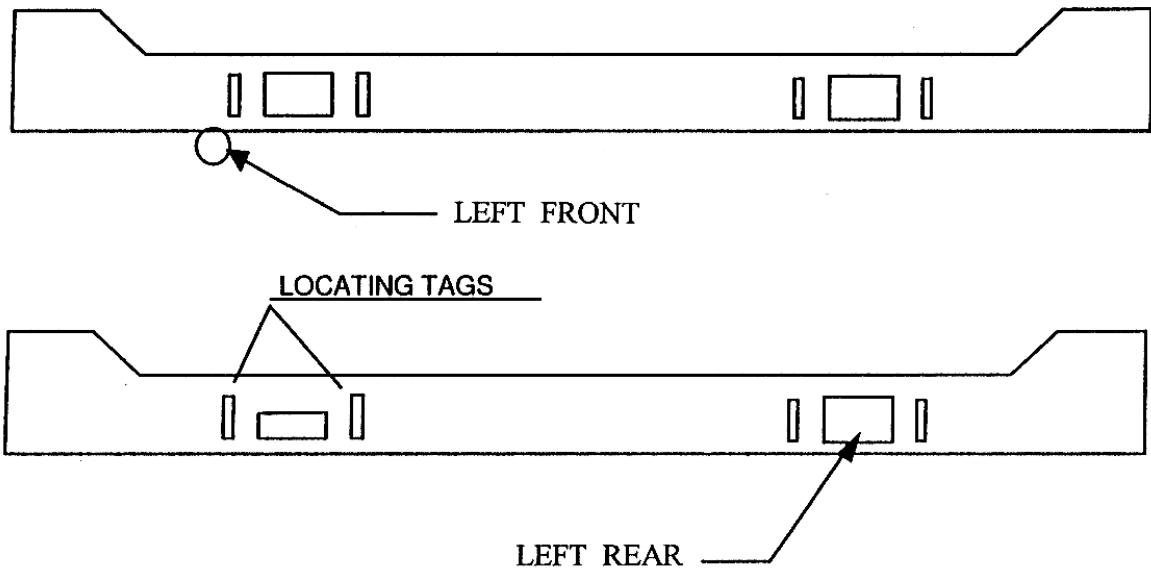
**NOTE:** To determine the front and rear crossmember assembly see Figure 3, and check the following:

6. The front crossmember assembly will have two (2) small openings for cable routing. The openings will face the rear of the lift.
7. The rear crossmember assembly will have one (1) small opening and one (1) larger opening for cable routing. These openings will face the front of the lift.
8. The crossmember assemblies are fully assembled and the PULLEYS DO NOT NEED TO BE REMOVED FOR CABLE INSTALLATION. ALIGN CROSS-MEMBER ASSEMBLIES SO THAT THE DIAGONALS MEASURE WITHIN HALF AN INCH SQUARE.
9. Install the crossmember assemblies under the front and rear of each deck assembly. The decks will fit inside the locating tabs of the crossmember assemblies. Install eight (8) 1/2 - 13 UNC x 1" lg. set screws to hold the decks to the crossmember assemblies. One set screw to the front and rear of each deck and one set screw into the four outer locating tabs on the front and rear crossmember assemblies.
10. Reposition work stands under front and rear crossmember assemblies.



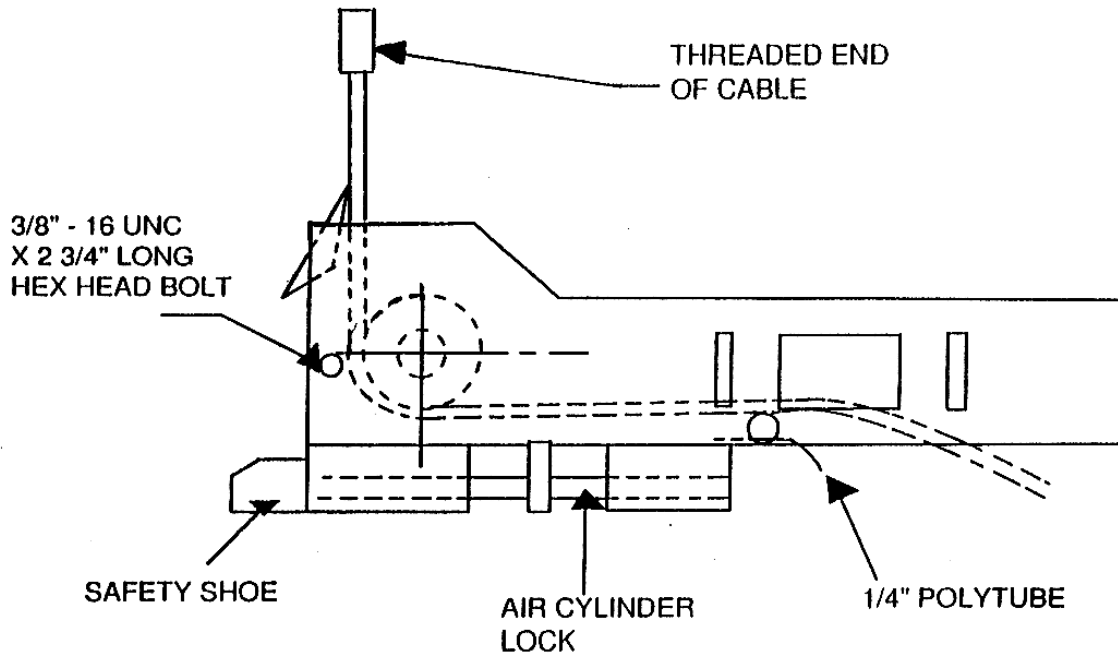
4.2 FRONT AND REAR CROSSMEMBER ASSEMBLY

FIGURE 3

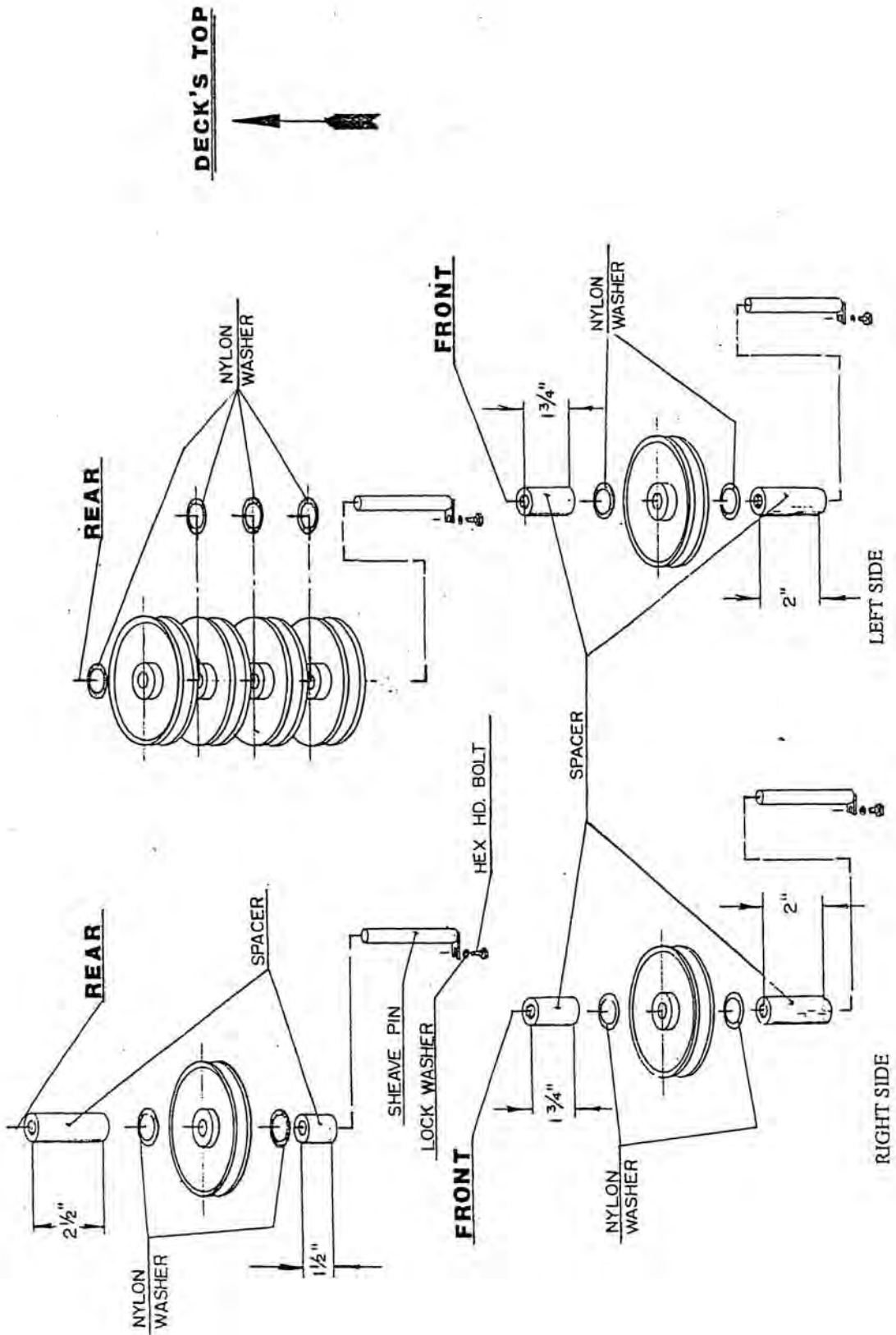


CABLE AND ROUTING IN CROSSMEMBER ASSEMBLY TYPICAL

FIGURE 4



### 4.3 SHEAVES INSTALLATION



#### 4.4 CABLE INSTALLATION

1. Locate the cables and lay them out on the floor. Check part numbers located on each stud of each cable.

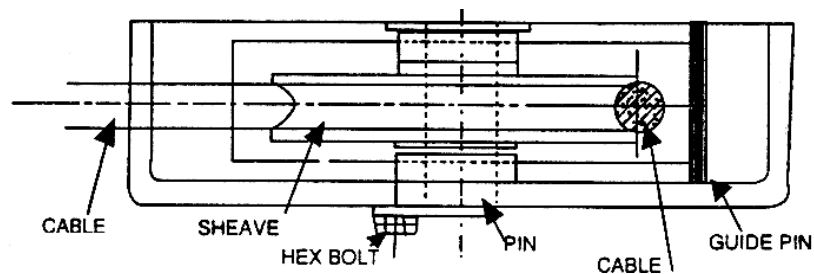
CABLE #1.....PART #2-0943 (314" lg. - L.F.)  
CABLE #2.....PART #2-0944 (144" lg. - L.R.)  
CABLE #3.....PART #2-0945 (194" lg. - R.R.)  
CABLE #4.....PART #2-0946 (361" lg. - R.F.)

**NOTE: THE PULLEYS (SHEAVES) ON THE CROSSMEMBERS DO NOT HAVE TO BE REMOVED FOR CABLE INSTALLATION. A 3/8" - 16 UNC × 2 3/4" LG. HEX HEAD BOLT MUST BE REMOVED FROM THE CROSSMEMBERS TO ALLOW CABLE INSTALLATION AROUND THE PULLEYS. THIS 3/8" - 16 UNC × 2 3/4" LG. HEX HEAD BOLT MUST BE REINSTALLED AFTER THE CABLES ARE ROUTED THROUGH THE CROSSMEMBER ASSEMBLIES.**

**WARNING!!! DO NOT APPLY LUBRICANT TO SHEAVE ASSEMBLY. FIBRE BUSHING IS PTFE SELF-LUBRICATING. THE ADDITION OF LUBRICANT WILL SHORTEN THE LIFE OF THE FIBRE BUSHING.**

2. Before beginning cable routing, refer to Figure 4, Cable and Routing Diagram.
3. Begin routing cable #4 (part #2-0946) from the right side of the front crossmember assembly using the non threaded end of the cable as described in Figure 4, and out through the opening under the front of the right deck.
4. CHECK FOR CORRECT ARRANGEMENT OF SPACERS ON SHEAVE STACKS, FIGURE 5.
5. Install the sheave into the front of the right deck as shown in Figure 5.

**NOTE: MAKE CERTAIN THAT THE CABLE RUNS BETWEEN THE WELDED GUIDE PIN AND THE GROOVE IN THE PULLEY.**



**NOTE:** Typical deck sheave arrangement. Left and right front deck shown; cable must run between the welded guide pin and the groove in the sheave. Left and right front spacers have equal top and bottom sizes.

**NOTE:** Similar arrangement for sheave stack. Right deck rear spacer sizes are not equal - the larger one goes on top of stack.

## **SHEAVE STACK FIGURE 6**

6. Continue to pull cable #4 over the center support of the right deck.
  7. Begin routing cable #3 (Part # 2-0945) from the right rear crossmember assembly using the non threaded end of the cable as described in figure 4, and out through the crossmember assembly to the opening under the rear of the right deck.
- TIP:** TAPE THE TWO CABLES TOGETHER, CABLE #3 ON TOP OF CABLE #4. THIS WILL KEEP THE TWO CABLES FROM TWISTING IN THE REAR CROSSMEMBER ASSEMBLIES.
8. Continue to feed cables #3 and #4 through the rear crossmember assembly and out of the opening under the rear of the left deck.
  9. Install the sheave into the rear of the right deck as shown in figure 5.
  10. Route cable #2 (Part # 2-0944) from the left side of the rear crossmember assembly using the non threaded end of the cable as described in figure 4, and out through the crossmember assembly to the opening under the rear of the left deck.
  11. Route cable #1 (Part # 2-0943) from the left side of the front crossmember assembly using the non threaded end of the cable as described in figure 4, and out through the crossmember assembly to the opening under the front of the left deck.
  12. Install the sheave into the front of the left deck as shown in figure 5.
- NOTE:** MAKE CERTAIN THAT ALL CABLES ARE IN THE RIGHT POSITIONS AND ARE NOT TWISTED. VERIFY THAT ALL FOUR (4) OF THE 3/8"-16 UNC x 2 3/4" LG. HEX HEAD BOLTS ARE REINSTALLED ON THE CROSSMEMBER ASSEMBLIES.
13. Install the sheave stack assembly at the rear of the left deck as shown in figure 5, Sheave Installation.
- NOTE:** ALL POSTS HAVE SAFETY RACKS ALREADY INSTALLED. THE LEFT FRONT POST WILL HAVE A MOUNTING BRACKET FOR THE POWER PACK INSTALLATION.
14. Stand posts into position according to figures 1 and 2.
  15. Install the threaded stud end of the cables through the top of the post. Use a 7/8" flat washer, and two (2) 7/8"-14 UNF hex nuts with cable spacers as required, to compensate for uneven floors.

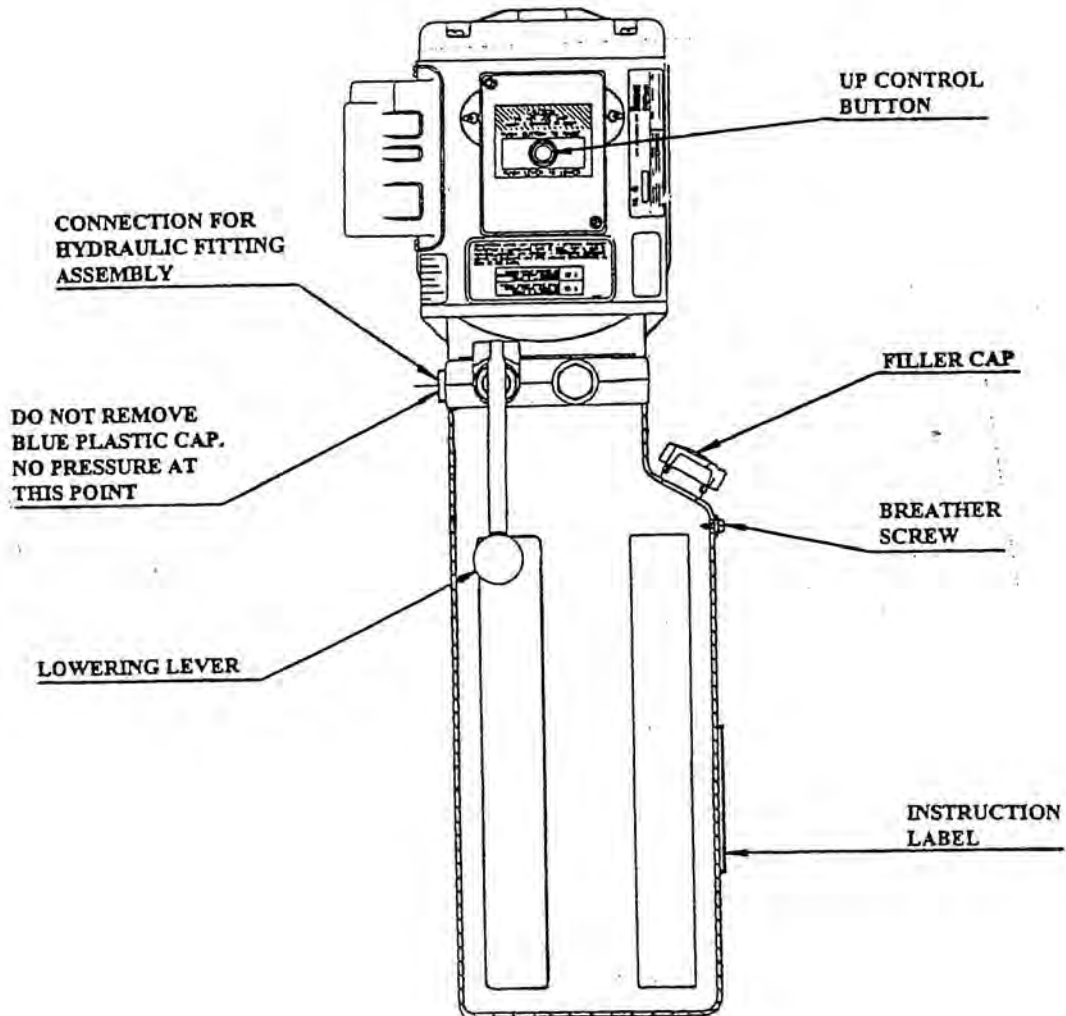
**NOTE:** Hydraulic cylinder is precharged with hydraulic fluid. Install power pack and hydraulic hose before attempting to extend cylinder rod for cable installation.

## POWER PACK INSTALLATION

1. Bolt the power pack to the mounting bracket on the front face of the left front post using four (4) 5/16"-18UNC x 1"LG. hex head bolts and four 5/16" lockwashers. Refer to Figure 7.

**NOTE: WHEN WORKING WITH HYDRAULIC LINES AND VALVES, IT IS IMPORTANT TO KEEP ALL COMPONENTS CLEAN AND FREE OF DIRT.**

**POWER PACK DETAILS  
FIGURE 7**

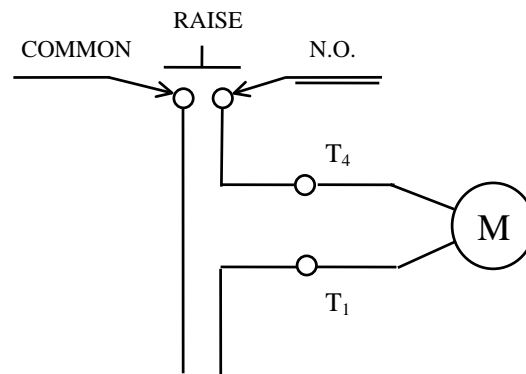


## 4.6 ELECTRICAL CONNECTIONS

**CAUTION:** ALL ELECTRICAL CONNECTIONS SHOULD BE MADE BY A QUALIFIED ELECTRICIAN.

Please refer to Figure 8, Electrical Diagram for 220 volts/single phase, electrical connections. Electrical Breaker Size Recommendation: 20Amps

### Electrical Diagram for 220V/1ph.



**FIGURE 8**

**NOTE:** THE CYLINDER ROD MUST BE EXTENDED IN ORDER TO INSTALL THE NON-THREADED END OF THE CABLES TO THE CABLE FLANGE ON THE ROD.

Remove the hydraulic cap from the fitting at the base of the hydraulic cylinder.

Use an air chuck and blow air into the fitting in the breather hole in the base of the cylinder to extend the rod.

**NOTE:** AS ROD EXTENDS, OIL FROM CYLINDER RETURNS TO POWER PACK.

Continue to extend the rod until the non-threaded end of the cables are reached.

Remove the clamp from the cable flange.

Install the cables as shown in Figure 4, Cable and Routing Diagram.

Reinstall the clamp to the cable flange.

## HYDRAULIC AND AIR KITS INSTALLATIONS

1. Locate the supply lines: 1/4" and 3/8" polytube, 3/8" flexible hydraulic line, and the black plastic piping.
2. Install the black plastic piping to the steel pipe welded to the underside of the front left side crossmember assembly.

### 4.7 HYDRAULIC INSTALLATION

1. Refer to Parts Manual, and Hydraulic and Air Kit Diagram

**TIP:** TAPE ONE END OF THE HYDRAULIC HOSE TO THE TWO POLYTUBES AND FEED THEM THROUGH THE BLACK PLASTIC PIPING. THEN REMOVE THE TAPE.

2. Connect 3/8" JIC, M end of the flexible hydraulic hose to the fitting at the cylinder.

**DO NOT OVER TIGHTEN.**

3. Install flow control assembly.
4. Attach the other end 3/8" JIC, F of the flexible hydraulic hose to the adapter fitting on the power pack (3/8" JIC, M).

**NOTE:** THE HYDRAULIC CYLINDER IS NOT EMPTY.

**NOTE:** THE PLASTIC PLUG ON THE POWER PACK IS NOT USED. THERE IS NO HYDRAULIC PRESSURE.

### 4.8 AIR INSTALLATIONS

1. Attach the air valve assembly using two (2) #8 - 32 UNC × 1" lg. Phil. HD. screws to the two (2) #8 - 32 UNC hex nuts on the outside face of the left front post.

**NOTE:** MOST OF THE 1/4" AND 3/8" POLYTUBE CONNECTIONS HAVE BEEN MADE IN THE CROSSMEMBERS ASSEMBLIES AND LEFT DECK. ONLY FINAL CONNECTIONS ARE REQUIRED TO BE MADE. THE 1/4" POLYTUBE WILL BE USED FOR THE AIR CYLINDER LOCKS AND THE 3/8" POLYTUBE WILL BE USED FOR THE AIR OUTLETS TO THE JACKING BEAMS.

**CAUTION:** DO NOT OVER TIGHTEN CONNECTORS.

2. Connect all of the 1/4" polytubes, coming out of the black plastic piping at the left front crossmember assembly, to the bolted manifolds at the front and rear of the left deck.

3. Connect the opposite end of the 1/4" polytube, coming out of the black plastic piping, to the air valve on the outside face of the left front post.
4. Connect the 3/8" polytube, coming out of the black plastic piping at the left front crossmember assembly, to the 3/8" polytube fitting located under the front inside of the left deck.
5. Connect the opposite end of the 3/8" polytube, coming out of the black plastic piping, to the air valve outlet on the outside face of the left post.

**NOTE:** FOR THOSE UNITS EQUIPPED WITH JACKING BEAMS, THIS WOULD BE THE TIME TO INSTALL THEM. CONSULT THE JACKING BEAM INSTRUCTIONS MANUAL FOUND IN EACH JACK BEAM BOX.

6. Hook up an air supply to the inlet of the water trap on the air valve assembly located on the outside of the left post. Check for air leaks.
7. Check the operation of the air cylinder locks by depressing the air valve on the outside of the left front post.
8. Press the "UP" button on the hydraulic power pack. Continue raising until the lift is supported by the cables.

**NOTE:** MAKE CERTAIN THAT THE MECHANICAL SAFETY LOCKS AND CABLE ROLLERS ARE WORKING PROPERLY.

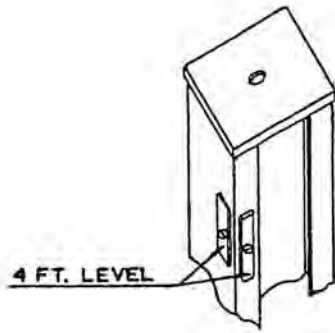
#### **4.9 LEVELING PROCEDURE - CABLES**

**NOTE:** A four (4) foot level is required. Adjust the cables to level the decks side-to-side and front-to-rear. All cable adjustments can be made at the threaded end of the cable at the top of each of the four (4) posts.

1. Tighten the two (2) 7/8" - 14 UNF hex nuts on each cable at the top of each post.
2. Raise the lift to check operation.
3. To lower, first raise lift off safety stops then lower lift by depressing the air valve while pulling down on the release lever of the power pack.
4. Remove hand from air valve and allow the lift to hang on the cables.
5. Use a four (4) foot level to square and level all four posts.
6. Begin leveling the highest post. Figure 9.

### **POST LEVELING**

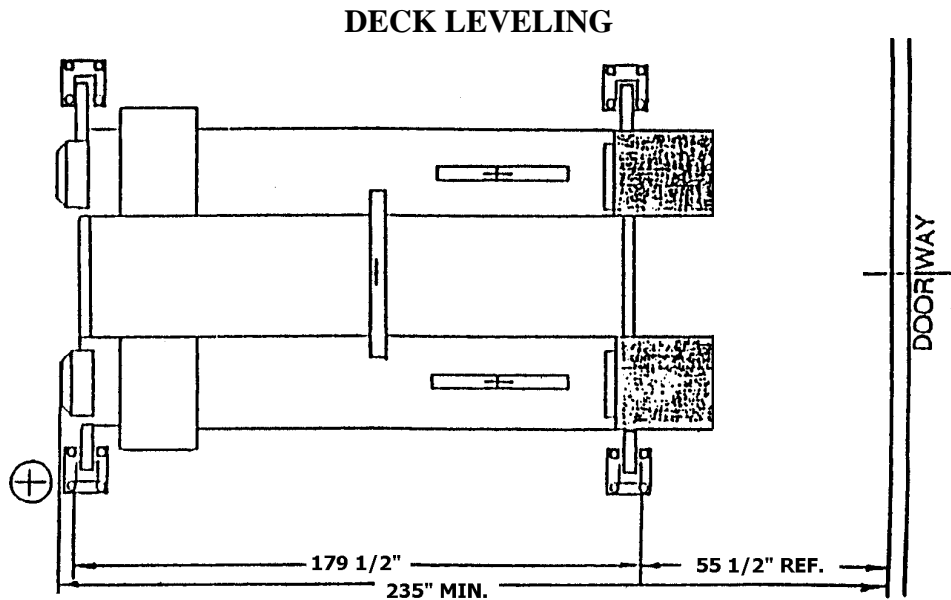




**FIGURE 9**

**NOTE:** MAKE CERTAIN THAT THE SAFETY RACK IN EACH OF THE POSTS IS SQUARE TO THE CROSSMEMBER ASSEMBLY AND THAT A MINIMUM CLEARANCE OF 1/8" IS MAINTAINED BETWEEN THE INSIDE FACE OF THE POSTS AND THE PLASTIC GUIDES ON THE CROSSMEMBER ASSEMBLY.

**CAUTION:** USE THE CORRECT WEDGE ANCHOR BOLTS. (SUPPLIED)



**FIGURE 10**

**NOTE:** Check and adjust the decks for level using the 4' level. Both the front plate cut-outs and rear steer plates should be checked.

#### 4.10 ANCHOR INSTALLATION

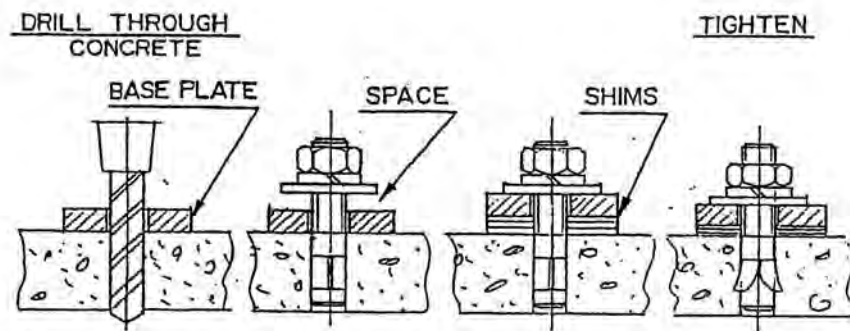
1. The 3/4" × 4 3/4" lg. wedge anchor bolts supplied allow for the thickness of the base plates plus a maximum of 1" of shim stock. **DO NOT USE ANCHORS SUPPLIED IF MORE THAN 1 INCH OF SHIM STOCK IS USED.**
2. Recheck all measurements before anchoring posts.

**Note: First anchor the power post, and then work clockwise.**

3. Using a 3/4" concrete drill bit and rotary hammer drill, drill through the concrete floor in the four (4) anchor bolt location holes positioned on the base of each post.

**Concrete grade: Lifts should only be installed on level concrete floors with a minimum thickness of five (5) inches. Concrete must have a minimum strength of 4,000 p.s.i. and should be aged 30 days prior to the installation of the lift.**

#### ANCHOR INSTALLATION



**FIGURE 11**

4. Tighten all anchor bolts to a torque of 150 ft. lbs.
5. Recheck and adjust the level of post(s) and cable(s) if necessary.

**NOTE: IN CASES WHERE THE FLOOR IS EXTREMELY OUT OF LEVEL, THE MECHANICAL SAFETIES MAY NOT ENGAGE ON THE SAME LOCK.**

#### **4.11 LEVELING PROCEDURE - SAFETY LADDERS**

1. After the lift has been leveled on the cables, adjust the safety racks.
2. To check the mechanical safety locks, raise the lift up; make sure all locks engage at the same time making one noise. If the safeties are off slightly, gently bump the up button until you hear the first safety lock engage. Determine at which post the safety engaged; adjust each of the other safety racks until you hear the safety engage. Recheck to make certain that the safeties are engaging together.
3. To do this loosen the 3/8" - 16 UNC × 1" lg. hex bolt at the bottom back of each post and pull safety racks up until they come into full contact with each of the safety shoes on the crossmember assembly.
4. When level, tighten the two (2) 5/8" - 11 UNC hex nuts at the top of each safety rack and the 3/8" - 16 UNC × 1" lg. hex bolts at the bottom back of each post.
5. Raise the lift to check for full operating height of 71". This measurement is taken from the top of the decks to the floor.
6. Install the approach ramps using ramp pins, cotter pins, and ramps provided. Ensure the proper operation of the ramps.
7. Install the front wheel stops using six (6) 1/2" - 13 UNC × 1" lg. hex bolts and six 1/2" lockwashers.
8. Install the four (4) sheave covers over the sheaves in the crossmember assembly.
9. Cycle the lift several times to check proper operation of the cables, safety lock, air locks, etc...

**STOP IMMEDIATELY IF THE LIFT IS NOT OPERATING PROPERLY.**  
Adjust and recheck for proper operation.

## 5. SAFETY AND OPERATING INSTRUCTIONS

1. **Inspect** your lift daily. Do not operate it if malfunctions occur or damaged parts have been found.
2. **Never** attempt to overload the lift. The manufacturer's rated capacity is shown on the serial number tag on the power post.
3. **Operating controls, DO NOT OVERRIDE** the safeties. The mechanical safeties are designed to engage automatically on the way up. Press the up switch of the power pack to go up. When the desired height is reached, lower onto the safety. To lower, raise off of the safety locks, then press the air release valve and the lowering release lever at the same time.
4. **Only trained** and authorized personnel should operate the lift. Do **not** allow customers or bystanders to operate the lift or be in the lift area.
5. **Caution**, never work under the lift unless the mechanical safety locks are engaged.
6. **Before** driving vehicle on, make sure lift is in the fully down position.
7. **Before** removing the vehicle from the lift, make sure the lift is in the fully down position and ensure that all tools have been removed from the deck surfaces.
8. **Always** keep the lift area free from debris. Grease and oil spills should always be cleaned up immediately. **Never** leave any tools or parts laying on the decks.
9. **Never** operate lift with passengers in vehicle.

**NOTE: DO NOT ATTEMPT TO OPERATE THIS LIFT IF ANY PART IS NOT WORKING PROPERLY OR YOU HAVE NOT READ THE COMPLETE OPERATING INSTRUCTION MANUAL.**

## 6. RECOMMENDED MAINTENANCE GUIDELINES

### **Safety Instructions**

- Read operating and safety manuals before using any lift
- Do not operate a lift that has been damaged or is in disrepair.
- Proper inspection and maintenance is necessary for safe operation.
- An in-line filter/regulator/lubricator should be installed on all airlines and maintained weekly.

### **4-Post Lift: Daily**

- Check general operation of lift.
- Check operations of mechanical safety locks.
- Check all air and hydraulic lines and fittings for pinch points, damage, cracks or leaks.
- Check all electrical wiring for pinch points, cracks or damage.
- Check operation of cables and pulleys.
- Check and drain water trapped in filter bowl.
- Check all moving parts for uneven or excessive wear.
- Repair or replace all damaged, defective, worn or broken components Immediately.
- Clean roller jack rails

### **4-Post Lift: Monthly**

- Check anchor bolts (if loose re-torque to 150 ft. lbs.). Replace concrete if anchors continue to loosen.
- Check all air and hydraulic hoses, fittings and cylinders for leaks.
- Check level of oil in power pack reservoir when lift is in the lowered position. Add if required.
- Check cables for fraying and adjustment. Lubricate cables with cable or penetrating oil every six months.
- Check all fasteners and tighten as required.
- Check all sheaves on crossmember assembly and under the runways for wear or play. Replace immediately. Pulley pins are held in place by 3/8" - 16UNC x 1"lg. Hex Hd. bolts. Make certain that these bolts are in position and tight.

### **WARNING!!!**

**DO NOT APPLY LUBRICANT TO SHEAVE ASSEMBLY. FIBRE BUSHING IS PTFE SELF-LUBRICATING. THE ADDITION OF LUBRICANT WILL SHORTEN THE LIFE OF THE FIBRE BUSHING.**

- Check and adjust safety racks if lift is not level on safety, or if safeties do not engage properly.
- If lift is equipped with rear slip plates > dismantle, clean, touch up deck surface if required, and rotate bearing cage every four months ( more frequent if necessary )
- Lubricate all safety shoes and locks every six months.
- Clean front turntable bearing cage with air.
- If lift is equipped with slide blocks, clean and re-grease slide block channels in each column every two months
- Change hydraulic oil every two years.

### **Quarterly Slip Plate Maintenance**

- Remove top Slip Plate covers by first removing the four (4) shoulder bolts on each cover.
- Remove polyethylene-bearing cages insuring that all the delrin bearings remain in the cages. Additional delrin bearings may be purchased if required.
- Clean runway surface and touch up any paint wear with a rust resistant paint. Allow paint to dry thoroughly.
- To obtain optimum performance, the position of the slip plate bearing cage should be rotated every quarter to change the wear pattern. With the first quarter maintenance, flip the bearing cage over to the opposite side. With the second quarter maintenance, rotate the bearing cage end-to-end. With the third quarter maintenance, flip bearing cage over to the opposite side. Fourth quarter maintenance should see the bearing cage rotated back to the position it started in.
- Quarterly maintenance will optimize performance and contribute to longer slip plate life.

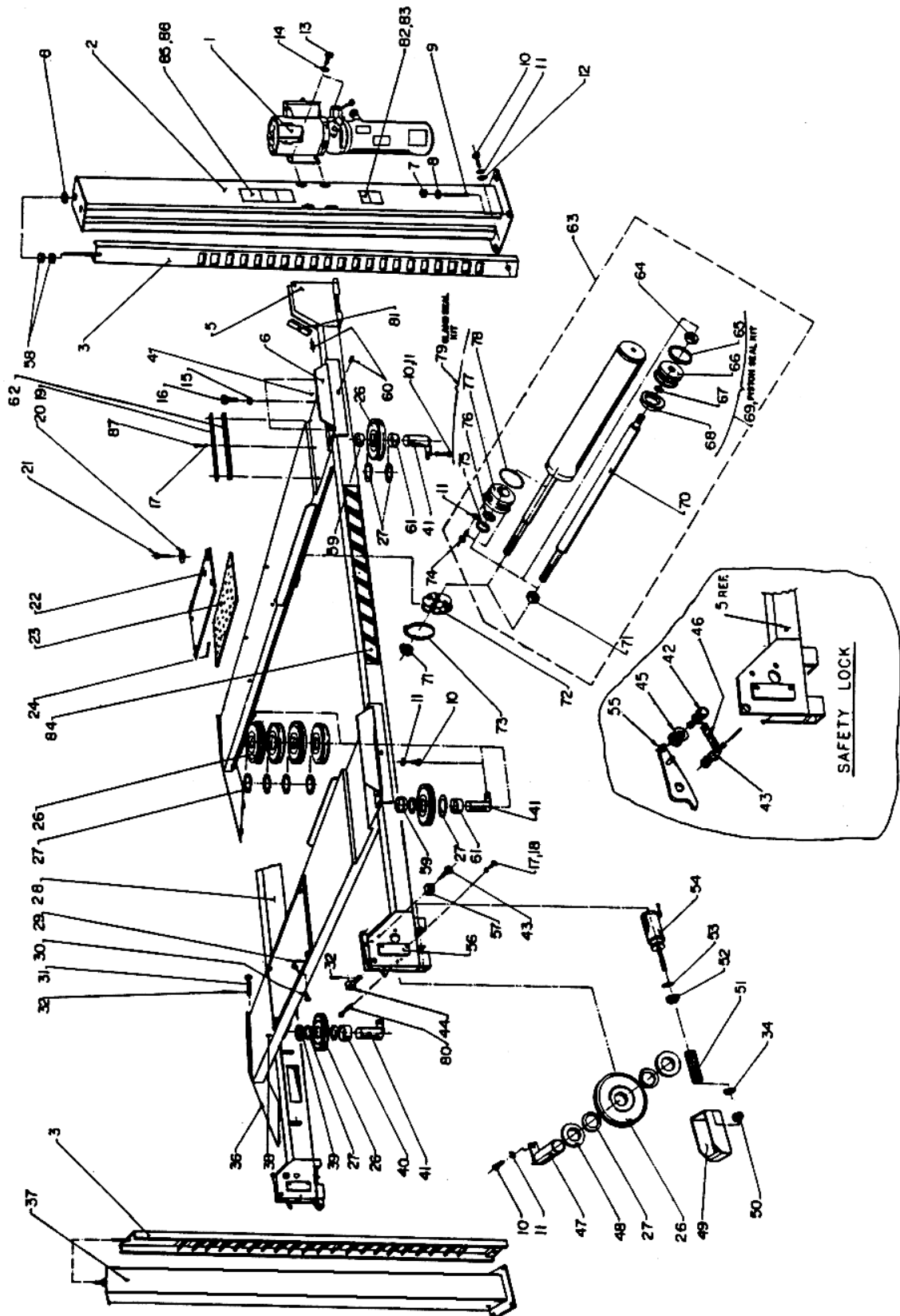
### **Rolling Air Jacks**

- An in-line filter/regulator/lubricator should be installed close to the pump . Add a few drops of oil to the air intake weekly if no lubricator is used or when idle for a long period of time.
- Lubricate roller bearings and roller guide springs every two months
- Dismantle and clean lift arms every four months
- Clean and lubricate lower cam rollers and hinge points every six months
- Clean and lubricate safety mechanism every six months
- Change hydraulic oil every two years

### **Lubrication**

- |                                   |  |
|-----------------------------------|--|
| Where grease is required          | > multi-purpose lithium grease             |
| Where lubricating oil is required | > multi-purpose SAE 30 lubricating oil     |
| Where hydraulic oil is required   | > ISO 32 10W - non detergent hydraulic oil |

# 7. PARTS LIST



## PARTS LIST

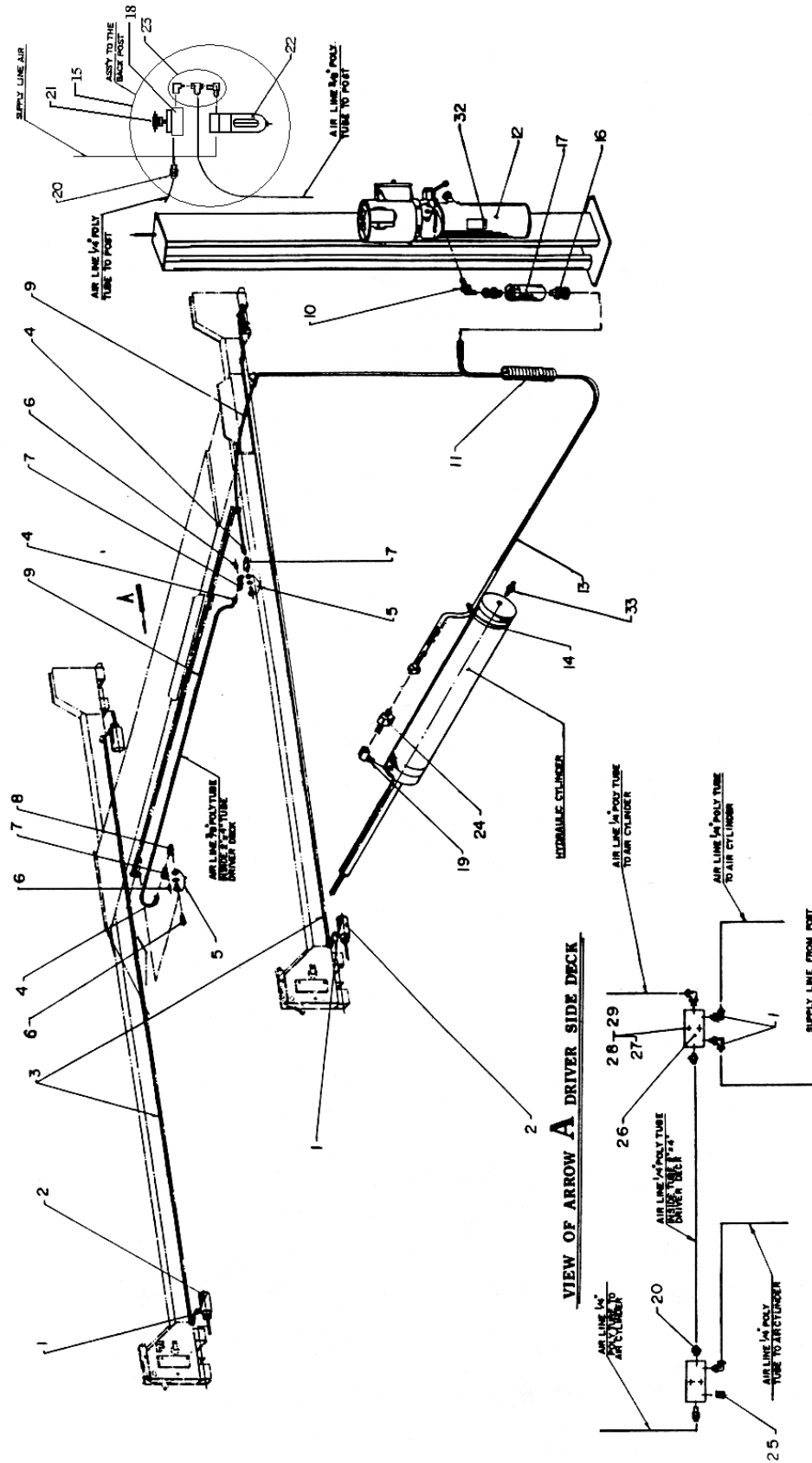
ITEM	QTY.	DESCRIPTION	PART#
1	1	POWER PACK, 220V/1PH/60HZ.	6-1936
2	1	POWER POST	4-0186
3	4	SAFETY RACK	3-0487
4	1	ALIGNMENT DECK WLDMT, (LEFT SIDE)	4-0357
5	1	FRONT CROSSMEMBER WELDMENT	4-0342
6	2	FRONT WHEEL STOP WELDMENT	2-0989
7	16	HEX NUT, 3/4"-10UNC	6-0737
8	24	FLAT WASHER, 3/4" I.D.	6-0738
9	16	WEDGE ANCHOR, 3/4"-10UNC X 4 3/4" LG.	6-0736
10	12	HEX HD. BOLT, 3/8"-16UNC X 1" LG. GR.8	6-0668
11	14	LOCKWASHER, 3/8" I.D.	6-0058
12	4	FLAT WASHER, 3/8" I.D.	6-0625
13	4	HEX HD. BOLT, 5/16"-18UNC X 3/4" LG.	6-0423
14	4	LOCKWASHER, 5/16" I.D.	6-0674
15	6	LOCKWASHER, 1/2" I.D.	6-0059
16	6	HEX HD. BOLT, 1/2"-13UNC X 1" LG.	6-0045
17	28	LOCKWASHER, 1/4" I.D.	6-0056
18	16	HEX HD. BOLT, 1/4"-20UNC X 3/4" LG.	6-0178
19	4	RETAINING BAR	2-0635
20	8	FLAT WASHER, 13/32" I.D. X 2" O.D.	6-0426
21	8	SHOULDER BOLT, 3/8" DIA. X 5/8" LG.	6-0069
22	2	REAR SLIP PLATE WELDMENT	3-0503
23	2	BEARING CAGE	2-0967
24	1	BALL BEARING SET	6-0829
26	11	SHEAVE ASSEMBLY	2-0557
27	19	NYLON THRUST WASHER	1-0757
28	1	REAR CROSSMEMBER WELDMENT	4-0341
29	4	LOCKING PIN ASSEMBLY	2-0637
30	4	SELF TAPPING SCREW, #10 X 1/2" LG.	6-0505
31	4	RAMP PIN	1-1887
32	4	COTTER PIN, 1/8" X 1 1/2" LG.	6-0978
34	8	FLAT WASHER, 1/4" I.D.	6-0060
36	2	APPROACH RAMP WELDMENT	3-0502
37	3	POST	3-0347
38	1	ALIGNMENT DECK WLDMT, (RIGHT SIDE)	4-0358
39	1	SHEAVE SPACER, 2 1/2" LG.	1-0798
40	1	SHEAVE SPACER, 1 1/2" LG.	1-0788



ITEM	QTY.	DESCRIPTION	PART#
41	4	DECK SHEAVE PIN	2-0566
42	4	SHOULDER BOLT, 3/8"DIA. X 1 1/2"LG.	6-0801
43	12	SHOULDER BOLT, 3/8"DIA. X 5/8"LG.	6-0069
44	4	LOCK SAFETY PIN	1-0769
45	4	CABLE ROLLER	1-0766
46	8	TENSION SPRING	1-0768
47	4	CROSSMEMBER SHEAVE PIN	1-0771
48	8	SHEAVE SPACER, 3/8"LG.	1-0786
49	4	SAFETY SHOE WELDMENT	2-0990
50	4	HEX NYLON LOCKNUT, 1/4"-28UNF	6-1563
51	4	COMPRESSION SPRING	1-0767
52	4	HEX NUT, 5/8"-18UNF	6-0662
53	4	INTERNAL TOOTH LOCKWASHER, 5/8"I.D.	6-0663
54	4	AIR CYLINDER, 5 1/2" ROD LG. (SPR-12)	6-0651
55	2	SAFETY LOCK WLDMT. LS	2-0567
	2	SAFETY LOCK WLDMT. RS	2-1475
56	8	PLASTIC BRACKET	1-0775
57	8	PLASTIC GUIDE	1-0776
58	8	HEX NUT, 5/8"-11UNC, GR.8	6-0036
59	2	SHEAVE SPACER, 1 3/4"LG.	1-0799
60	8	SET SCREW, 1/2"-13UNC X 1"LG. GR.8	6-0726
61	2	SHEAVE SPACER, 2"LG.	1-0943
62	4	SPACER BAR	2-0636
63	1	HYDRAULIC CYLINDER	4-0187
64	1	LOCKNUT, 7/8"- 14UNF, NYLON INSERT	6-1160
65	1	WEAR RING	6-0004
66	1	PISTON	2-0564
67	1	"O" RING	6-1305
68	1	PISTON SEAL	6-0003
69	1	PISTON SEAL KIT	0-0169
70	1	PISTON ROD	2-0565
71	2	HEX NUT, 1"-14UNF-2A, GR.8	6-0664
72	1	CABLE FLANGE	2-0561
73	1	CLAMP	6-0665
74	2	HEX HD. BOLT, 3/8"-16UNC X 1 1/4"LG. GR.8	6-0666
75	1	ROD WIPER	6-0653
76	1	ROD SEAL	6-0654
77	1	GLAND	3-0348
78	1	"O" RING	6-0655
79	1	GLAND SEAL KIT	0-0170
80	4	HEX HD. BOLT, 3/8"-16UNC X 2 3/4"LG.	6-0730
81	4	SHEAVE COVER	2-0575

<b>ITEM</b>	<b>QTY.</b>	<b>DESCRIPTION</b>	<b>PART#</b>
82	1	SERIAL TAG	6-1114
83	1	“ALI/ETL” TAG	6-0996
84	2	“CAUTION” TAPE, (40”LG.)	6-1125
85	1	DECAL SET, ALI/WL 200	6-0988
87	12	HEX HD. BOLT, 1/4”-20UNC X 1 1/4”LG.	6-0027
88	1	“ATTENTION” DECAL	6-1637

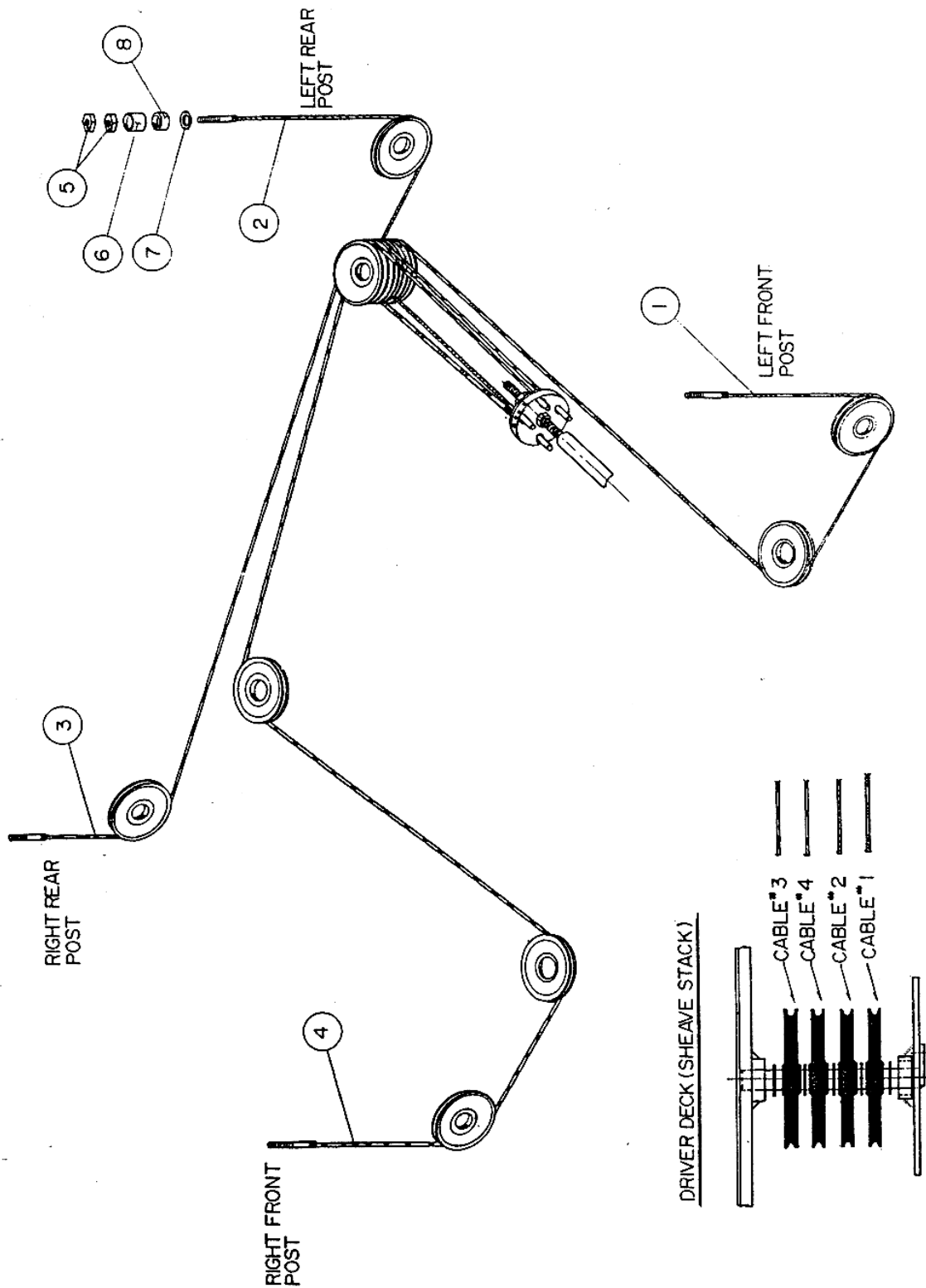
# HYDRAULIC AND AIR KITS ASSEMBLY



## HYDRAULIC AND AIR KITS PART LIST

ITEM	QTY.	DESCRIPTION	PART#
1	8	90° ELBOW, 1/8"NPT X 1/4"POLY TUBE	6-0709
2	4	AIR CYLINDER	6-0651
3	50 FT.	1/4" DIA. POLY TUBE	6-0706
4	3	ADAPTER, 3/8" POLY TUBE X 1/4"NPT	6-0710
5	2	TERMINAL BOLT, 3/4"	6-0713
6	2	PLUG, 1/4"NPT	6-0282
7	3	1/4" NPT STREET TEE	6-0014
8	1	1/4" NPT STREET ELBOW	6-0015
9	25 FT.	3/8" DIA. POLY TUBE	6-0707
10	1	90° ADAPTER, 3/8"JIC M X 9/16"-18 M	6-0804
11	4 FT.	HOSE GUARD	6-0714
12	1	POWER PACK 230V/1 PH/60HZ.	6-1936
13	1	HYD.HOSE ASS'Y, 3/8"SWIVELx3/8"JICM,147"LG.	6-0715
14	3	CABLE TIE	6-0731
15	1	AIR VALVE & FILTER ASS'Y	2-1394
16	2	ADAPTER, 3/8"NPT M X 3/8"JIC F, SWIVEL	6-0797
17	1	FLOW CONTROL	6-1937
18	1	3-WAY AIR VALVE	6-1775
19	1	90° ELBOW, 1/4"NPT M X 3/8"NPT F	6-0796
20	4	ADAPTER, 1/4" POLY TUBE X 1/8"NPT	6-0708
21	1	AIR VALVE PUSHBUTTON KIT	6-1777
22	1	AIR FILTER ASSEMBLY	6-0772
	1	AIR FILTER ELEMENT, (REPLACEMENT)	6-0180
23	1	AIR VALVE FITTING KIT	0-0405
24	1	VELOCITY FUSE	6-1684
25	1	PLUG, 1/8" NPT	6-0182
26	2	MANIFOLD	1-1057
27	4	HEX HD.CAP SCREW, 1/4"-20UNC X 1 1/2"LG.	6-0205
28	4	HEX NUT, 1/4"-20UNC	6-0032
29	4	LOCKWASHER, 1/4" I.D.	6-0056
32	1	"LIFT OPERATION" DECAL	6-0593
33	1	ADAPTER, 1/8"NPT M X 1/4"JIC M	6-0280

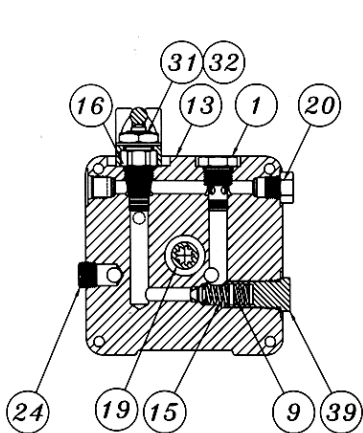
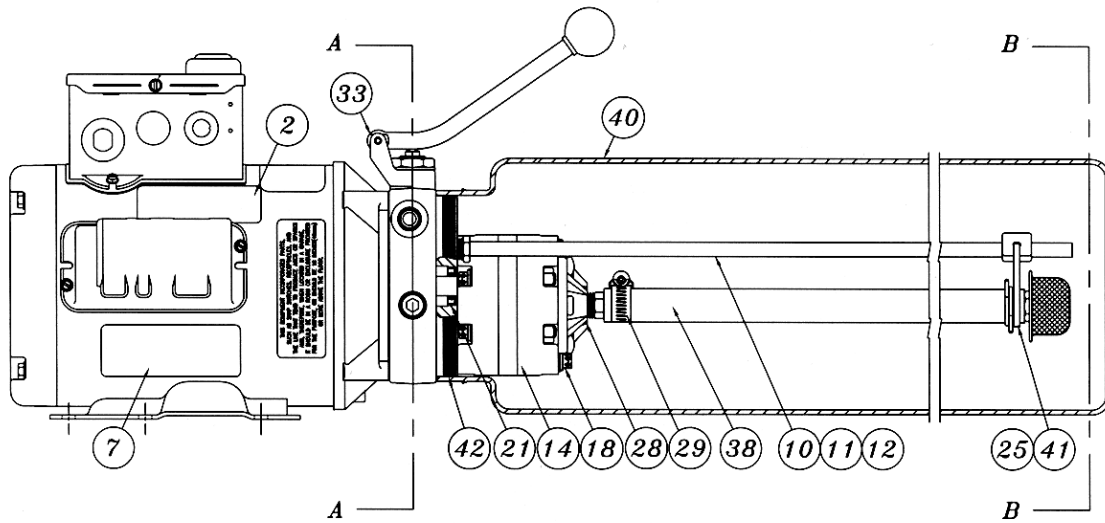
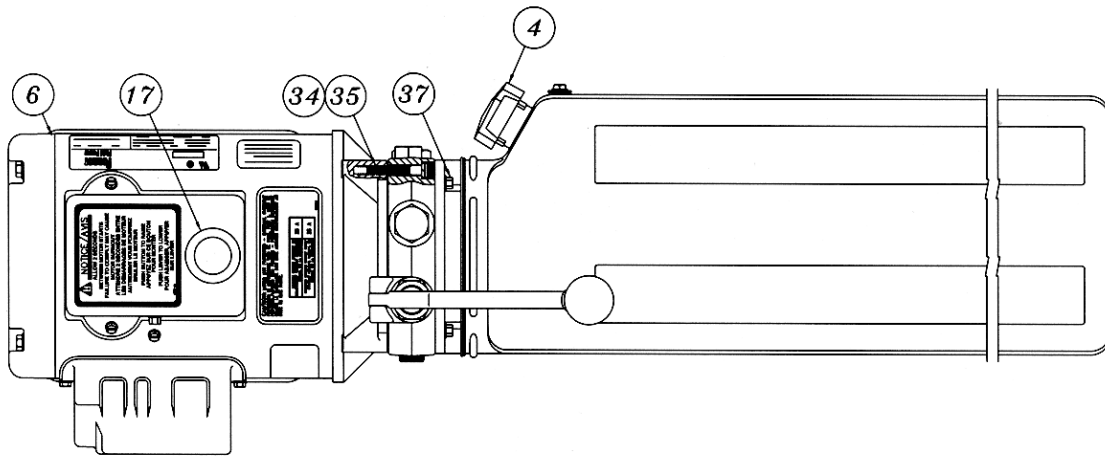
# CABLE ROUTING DIAGRAM



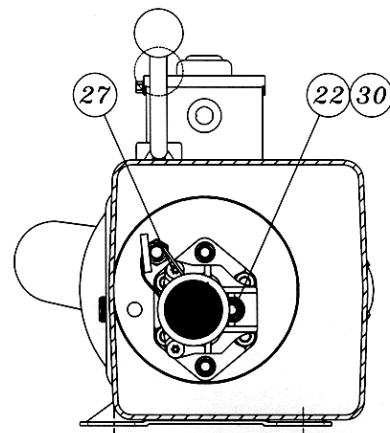
## CABLE ROUTING PARTS LIST

<b>ITEM</b>	<b>QTY.</b>	<b>DESCRIPTION</b>	<b>PART#</b>
1	1	CABLE ASSEMBLY, 314"LG. (LEFT-FRONT)	2-0943
2	1	CABLE ASSEMBLY, 144"LG. (LEFT-REAR)	2-0944
3	1	CABLE ASSEMBLY, 194"LG. (RIGHT-REAR)	2-0945
4	1	CABLE ASSEMBLY, 364"LG. (RIGHT-FRONT)	2-0946
5	8	HEX NUT, 7/8"-14UNF, GR.8	6-0724
6	4	CABLE SPACER, 2"LG.	1-0800
7	4	FLAT WASHER, 7/8" I.D.	6-0725
8	4	CABLE SPACER, 1"LG.	1-0801

**POWER PACK: #6-1936 (AB-1400) 208-230V/1PH/60Hz**



A-A



B-B

**POWER PACK PARTS LIST: #6-1936 (AB-1400) 208-230V/1PH/60Hz**

ITEM	QTY.	DESCRIPTION	PART #
1	1	VALVE CARTRIDGE CHECK	6-1087
2	1	LABEL INSTALLATION AUTOHOIST	6-2136
4	1	BREATHER CAP & BLADDER	6-1376
6	1	MOTOR AC 208-230V. 2HP/1PH/60Hz, BLK	6-2139
7	1	LABEL WARNING AUTOHOIST	6-2149
9	1	SPRING 0.480" x 0.063" x 0.42" COMP	6-2151
10	1	RETURN HOSE 3/8" OD x 21.5"	6-2152
11	1	COMPRESSION TUBE NUT	6-2153
12	1	COMPRESSION TUBE SLEEVE	6-2154
13	1	ENDHEAD UNIVERSAL AUTOHOIST	6-2155
14	1	PUMPASSY 3.1 CC/REV. SHORT SPLINE	6-1688
15	1	RELIEF ASSEMBLY FIXED 170 BAR	6-1317
16	1	VALVE CARTRIDGE RELEASE MANUAL	6-0880
17	1	WIRING ASSEMBLY AC 1PH FENNER	6-2156
18	2	BOLT 5/16"-24 x 3.00" TORX G8	6-1090
19	1	COUPLING SAE 9T-20/40 1.260"	6-0774
20	1	PLUMBING PLUG 9/16" SAE	6-2157
21	1	SEAL SHAFT 0.500" x 1.00" x 0.25"	6-2158
22	1	WASHER 0.338" x 0.625" x 0.060" STEEL	6-2159
24	1	PLUMBING PLUG 3/8" NPT	6-2161
25	1	PLUMBING MAGNET	6-2162
27	2	SCREW TAPTITE M6 x 1.0 12MM TORX	6-2164
28	1	COVER ASS'Y SUCTION	6-2165
29	1	PLUMBING CLAMP HOSE ADJ. INLET	6-2166
30	1	BOLT 5/16"-18 x 1.00" SHCS	6-1392
31	1	NUT 3/4"-16 x 1" HEX x 0.250" STEEL	6-2167
32	1	WASHER 3/4" INT. TOOTH LOCK	6-2168
33	1	BRACKET - HANDLE ASSY REL BLACK	6-0776
34	4	BOLT M6 x 1.0 35MM SOC HD	6-2169
35	4	WASHER 1/4" LOCK HI-COLLAR	6-2170
37	4	BOLT #12-24 x 0.50" HEX WSHRHD	6-1091
38	1	PLUMBING ASSY INLET 17.24 (3)	6-0786
39	1	RELIEF VALVE CAP ASSEMBLY	6-1089
40	1	TANK PLASTIC 6.7 OS 22.50" BLK	6-1399
41	1	CABLE TIE 8" LONG WHITE	6-1846
42	1	O-RING 2-348 BUNA	6-0875



# CAUTION

ALL SAFETY LADDERS USED ON 4-POST LIFTS ARE PRELOADED.

**REMOVING THE BOLT HOLDING THE BOTTOM PORTION OF THE SAFETY LADDER WITHOUT PROPER PRECAUTIONS CAN RESULT IN INJURY.**

PLEASE CONTACT CUSTOMER SERVICE FOR PROPER REMOVAL INSTRUCTIONS.

