

INSTALLATION and OPERATION MANUAL

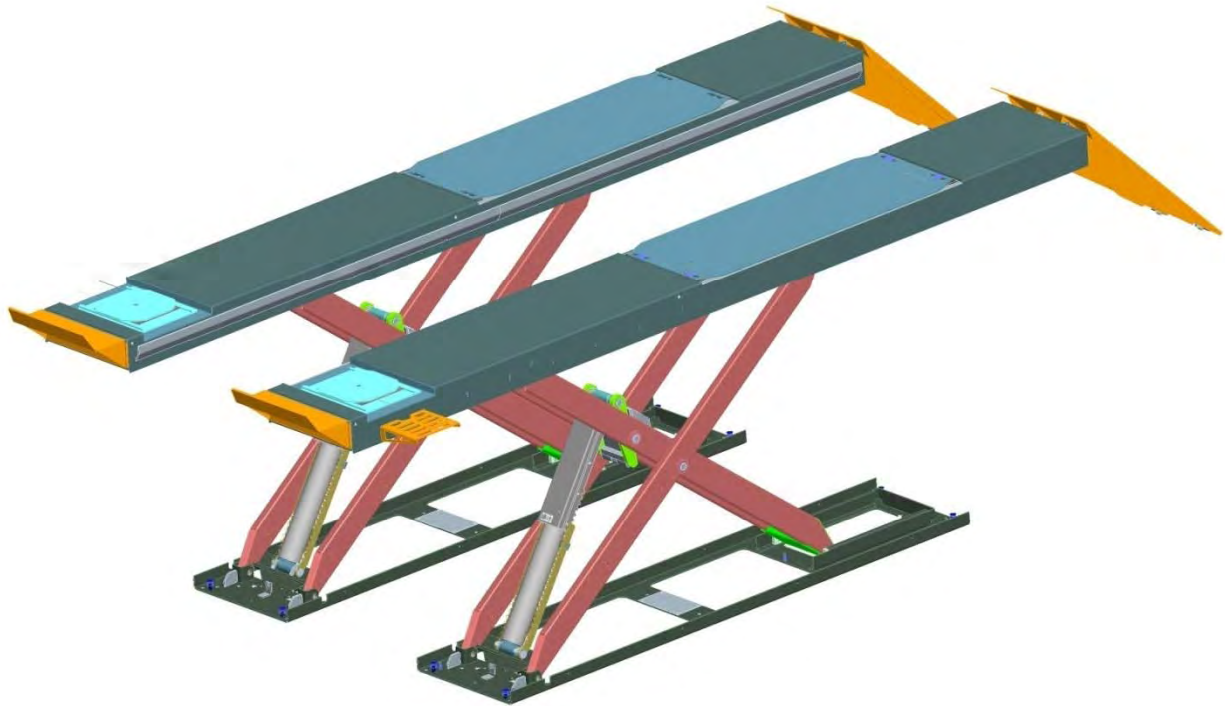

10K SCISSOR LIFT MODEL: 10605A_(F,FM,FX,FMX)

**READ THIS INSTRUCTION MANUAL THOROUGHLY BEFORE
INSTALLING, OPERATING, SERVICING OR MAINTAINING
THE LIFT.**

SAVE THIS MANUAL.

Table of Contents

1.0 SAFETY INSTRUCTIONS.....	4
2.0 SAFETY WARNING DECALS.....	6
3.0 SPECIFICATIONS	7
4.0 CONTENTS.....	8
5.0 TOOLS REQUIRED FOR INSTALL	8
6.0 INSTALLATION OVERVIEW.....	9
7.0 INSTALLATION INSTRUCTIONS	10
7.1 Flushmount Bay Layout	11
7.2 Surfacemount Bay Layout.....	12
7.3 Baseframe Location	13
7.4 Unpacking the Lift	14
7.5 Hydraulic Connections	15
7.6 Air Safety and Auxiliary Air Connection.....	16
7.7 Electrical Connection	17
7.8 Initial Run	18
7.9 Level and Support.....	19
7.10 Anchoring Procedure	21
7.11 Grouting Procedure (Optional)	22
8.0 ACCESSORY INSTALLATION	23
8.1 LINE COVER INSTALLATION.....	25
9.0 LOCKING FRONT TURNPLATES & REAR SLIP PLATES (OPTIONAL)	26
9.1 Installation of Front Turnplates.....	26
9.2 Console Connections for Locking & Lights.....	27
10.0 FINAL PROCEDURES	29
10.1 Check of Assembled Lift	29
10.2 Operation Test with Vehicle	29
11.0 LIFT OPERATION	30
11.1 Raising the Lift	30
11.2 Lowering the Lift.....	30
12.0 RECOMMENDED MAINTENANCE	31
12.1 Kicker Greasing Procedure	32
12.2 Checking Oil Level for Air Lubricator.....	32
12.3 Maintenance of Turnplate & Slip Plate Locking System (Opt.).....	33
12.4 Adjustment of Safety Locks.....	34
12.5 Maintenance Schedule.....	35
13.0 TROUBLE SHOOTING	36
14.0 LIFT ASSEMBLY.....	37
14.1 Lift Parts List	38
15.0 HYDRAULIC/AIR PARTS ASSEMBLY	40
15.1 Hydraulic/Air Parts List.....	41
16.0 Accessory assembly.....	42
16.1 Front Turnplate	42
16.2 Rear Slip Plate Locking Mechanism	44
16.3 Airline Routing for Locking Turnplates and Rear Slip Plates.....	45
16.4 Rear LED Light Assembly: Exploded View	47
16.5 Air Switch for Light Kit.....	49
17.0 CONSOLE ASSEMBLY	50

17.1 Console Parts List.....	51
17.2 Console Pneumatic / Filtering System	52
17.3 Console: Pneumatic & Filtering System - Locking & Light System (Optional).....	53
17.4 Console Labeling	54
18.0 POWER PACK ASSEMBLY.....	55
19.0 AVAILABLE ACCESSORIES	58

1.0 SAFETY INSTRUCTIONS

When using this lift, basic safety precautions should always be followed, including the following:

1. Read all instructions and safety information in this manual and on the lift thoroughly before installing, operating, servicing, or maintaining the lift.
2. Inspect the lift DAILY. Do not operate if it malfunctions or problems have been encountered.
3. Never attempt to overload the lift. The manufacturer's rated capacity is shown on the identification label on side of the deck. Do not override the operating controls or safety devices.
4. Only trained and authorized personnel should operate the lift. Do not allow customers or bystanders to operate the lift or be in the lift area.
5. **CAUTION! Never work under the lift unless mechanical safety locks are engaged.**
6. Always keep the lift area free of obstruction and debris. Grease and oil spills should always be cleaned up immediately.
7. Never raise a vehicle with passengers inside.
8. Always chock vehicle wheels before raising or lowering the lift.
9. Before lowering check the area for any obstructions including people.
10. To protect against risk of fire, do not operate the lift in the vicinity of open containers of flammable liquids.
11. Adequate ventilation should be provided when working on internal combustion engines.
12. Never open hydraulic lines under pressure.
13. Do not raise or lower the lift with the vehicle on the Jack Beam.

READ AND SAVE THESE INSTRUCTIONS

Installation shall be performed in accordance with ANSO/ALI ALIS, Safety Requirements for Installation and Service of Automotive Lifts.

For additional safety instructions regarding lifting, lift types, warning labels, preparing to lift, vehicle spotting, vehicle lifting, maintaining load stability, emergency procedures, vehicle lowering, lift limitations, lift maintenance, good shop practices, installation, operator training and owner/employer responsibilities, please refer to “Lifting It Right” (ALI/SM) and “Safety Tips” (ALI/ST).

For additional instruction on general requirements for lift operation, please refer to “Automotive Lift-Safety Requirements For Operation, Inspection and Maintenance” (ANSI/ALI ALOIM).



ATTENTION! This lift is intended for indoor installation only. It is prohibited to install this product outdoors. Operating environment temperature range should be 41 – 104 °F (5 – 40 °C). Failure to adhere will result in desertification, loss of warranty, and possible damage to the equipment.

SAFETY INSTRUCTIONS

If attachments, accessories or configuration modifying components that are located in the load path, affect operation of the lift, affect the lift electrical listing or affect intended vehicle accommodation are used on this lift and, if they are not certified for use on this lift, then the certification of this lift shall become null and void. Contact the participant for information pertaining to certified attachments, accessories or configuration modifying components.

www.autolift.org

©2007 by ALI, Inc.

ALI / WLSIAO1

+ 070126-Quadra-WLSIAO1

2.0 SAFETY WARNING DECALS

Be sure the operator is aware and understands all safety warning labels and follows them accordingly.

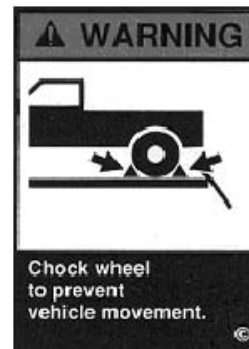
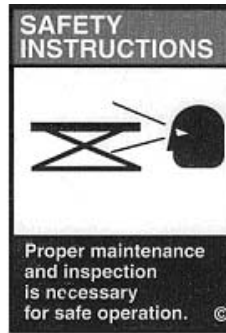

3.0 SPECIFICATIONS

Maximum Capacity:	10 000 lbs	4536 kg	
Overall Width (min-max):	92-1/2 -94-1/2 Inches	2350-2400 mm	
Overall Length:	172" W/B	265-3/8 Inches	6741mm
	155" W/B	255-3/8 Inches	6486mm
Maximum Raised Height:	72 Inches	1829 mm	
Minimum Lowered Height:	9 Inches	229 mm	
Runway Width	26 Inches	660 mm	
Lifting Time (approx.):	65 seconds at max. capacity		
Power Requirements:	230V, 1 Ph, 60 Hz, 18A		
Air Supply requirements:	90 to 120 PSI		
Pneumatic Filtration Oil Type:	Snap-On #IM6 or Equivalent		
Hydraulic Oil Capacity:	Tank size: 4.0 gal	Lift uses: 3.0 gal	
Hydraulic Oil Type:	ISO 32 (10 weight) hydraulic oil		
Shipping Weight:	4724 lbs	2143 kg	

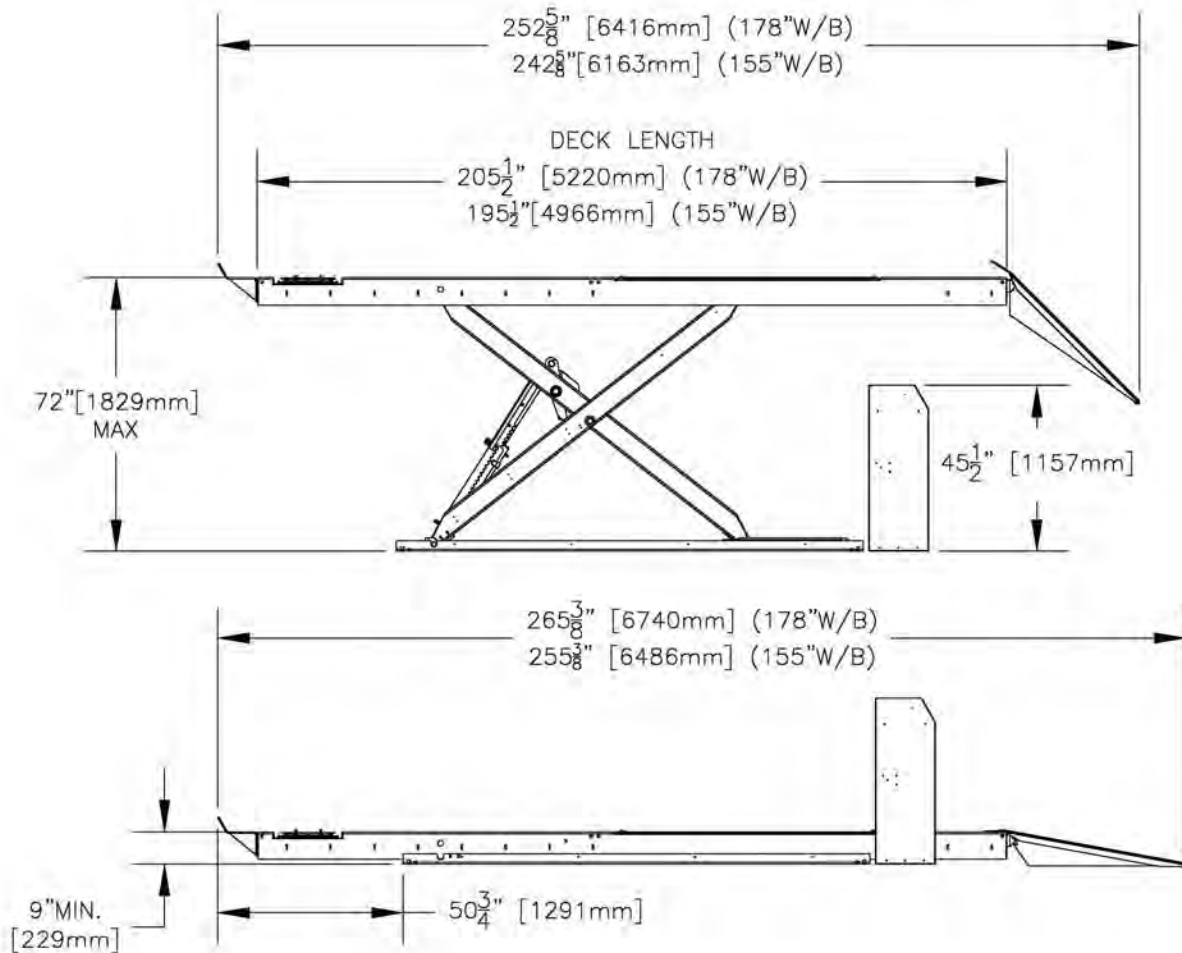

Figure 1 Lift Dimensions

4.0 CONTENTS

The complete lift is contained in two (2) packages:

1. The main structural components are pre-assembled and packaged on top of each other.
2. The remaining parts are packed in a console/accessory box. Refer to the packing slip inside for a list of contents.

Components include:

- 1pc. – Left Side Main Frame Assembly: Runway, Scissors and Base Frame
- 1pc. – Right Side Main Frame Assembly: Runway, Scissors and Base Frame
- 1pc. – Console and accessory box. (See accessory box list for contents)
- 1pc. – Grout container
- 1pc. – Customer care kit including manuals

5.0 TOOLS REQUIRED FOR INSTALL

Hammer Drill or similar, 1/4" and 1/2" Concrete Drill Bits
4' Level
SAE Wrenches and Sockets
Hammer
Pry Bar – 5' Long
Chalk Line
Tape Measure
Side Cutters
Screw Drivers
Funnel
Utility Knife
Torque Wrench

Recommended:

Laser Leveler
Plumb Bob
Impact Gun
Boom and/or Engine Hoist
8' Sling
Engine Crane

Note: Apply LOCTITE #242 on required fasteners where symbol is shown.
If fasteners are removed reapply LOCTITE before re-installing.



6.0 INSTALLATION OVERVIEW

This is the order in which this installation is to take place:

1. Layout the Bay
2. Unpacking of Lift
3. Inspect Lift
4. Connect Air Lines
5. Connect Hydraulic Lines
6. Connect Electrical
7. Temporary shimming under Kicker area. **IMPORTANT!!**
8. Initial Run of Lift
9. Level, Shim & Anchor
10. Install Accessories
11. Final Check
12. Clean
13. Train customer on operation of Lift

7.0 INSTALLATION INSTRUCTIONS

When the lift arrives on site, please read the Installation Manual completely. Check the contents to make sure no parts are missing before starting installation. Gather all of the tools listed and make sure that the instructions are fully understood before commencing with the installation.



IMPORTANT: It is the user's responsibility to provide a satisfactory installation area for the lift. Lifts should only be installed on a level concrete floor with a minimum thickness of four and a quarter inches (4¼") or 108 mm. Concrete must have a minimum strength of 3000 PSI or 21 MPa and should be aged thirty (30) days prior to installation. Please consult the architect, contractor or engineer if doubt exists as to the strength and feasibility of the floor to enable proper lift installation and operation.



IMPORTANT: It is the user's responsibility to provide all wiring for electrical hook-up prior to installation and to ensure that the electrical installation conforms to local building codes. Where required, it is the user's responsibility to provide an electrical isolation switch located in close proximity to the lift that will enable emergency stop capability and isolate electrical power from the lift for any servicing requirements.



WARNING: The floor surface must be inspected and the below requirements must be met.

NO Drains.

NO Depressions.

NO Holes or Pits.

In shaded area around lift



If more than ¼" depression in the kicker area (10" span), this area must be filled and leveled.

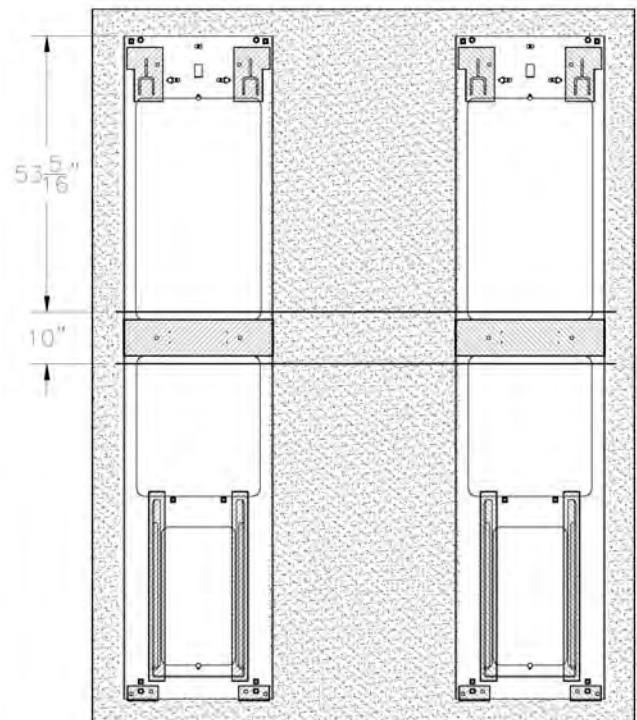
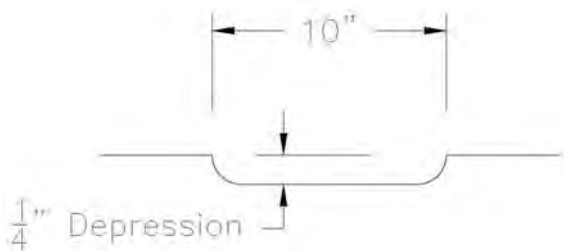

7.1 Flushmount Bay Layout

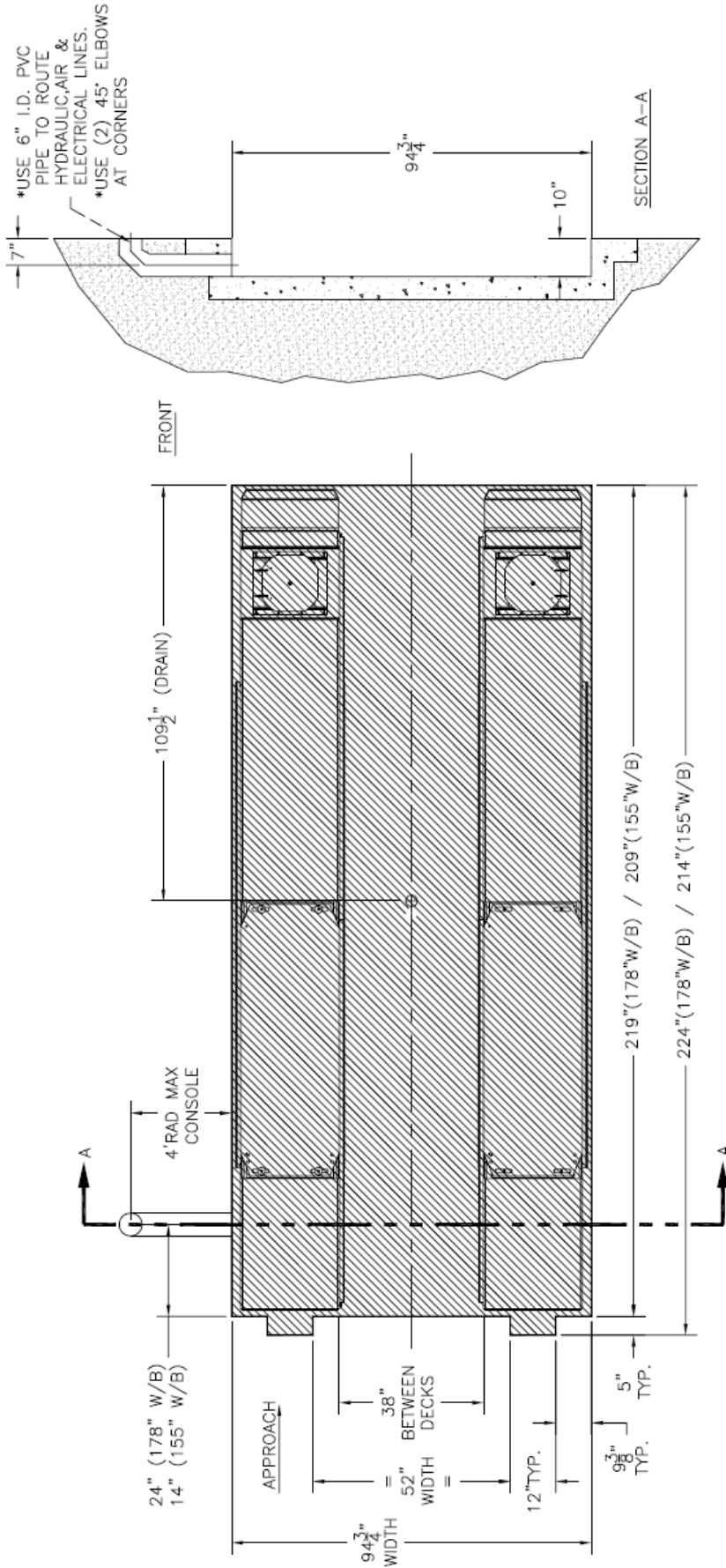

Note: Leave any additional room for any desired aisle or work area. Recommended clearance around the lift is three (3) feet. Ensure clearance conforms to local building and fire codes.

Recommended overhead clearance is a minimum twelve (12) foot ceiling providing 6 feet for the maximum lift height and 6 feet for the supported vehicle. For vehicles taller than 6 feet it is recommended that the user provides additional overhead clearance or a shut off mechanism to stop the lift from raising the vehicle too high.

Please contact customer service for latest installation diagram as it may change without notice.

Figure 2 - Typical Bay Layout (Flush Mount)

7.2 Surfacemount Bay Layout

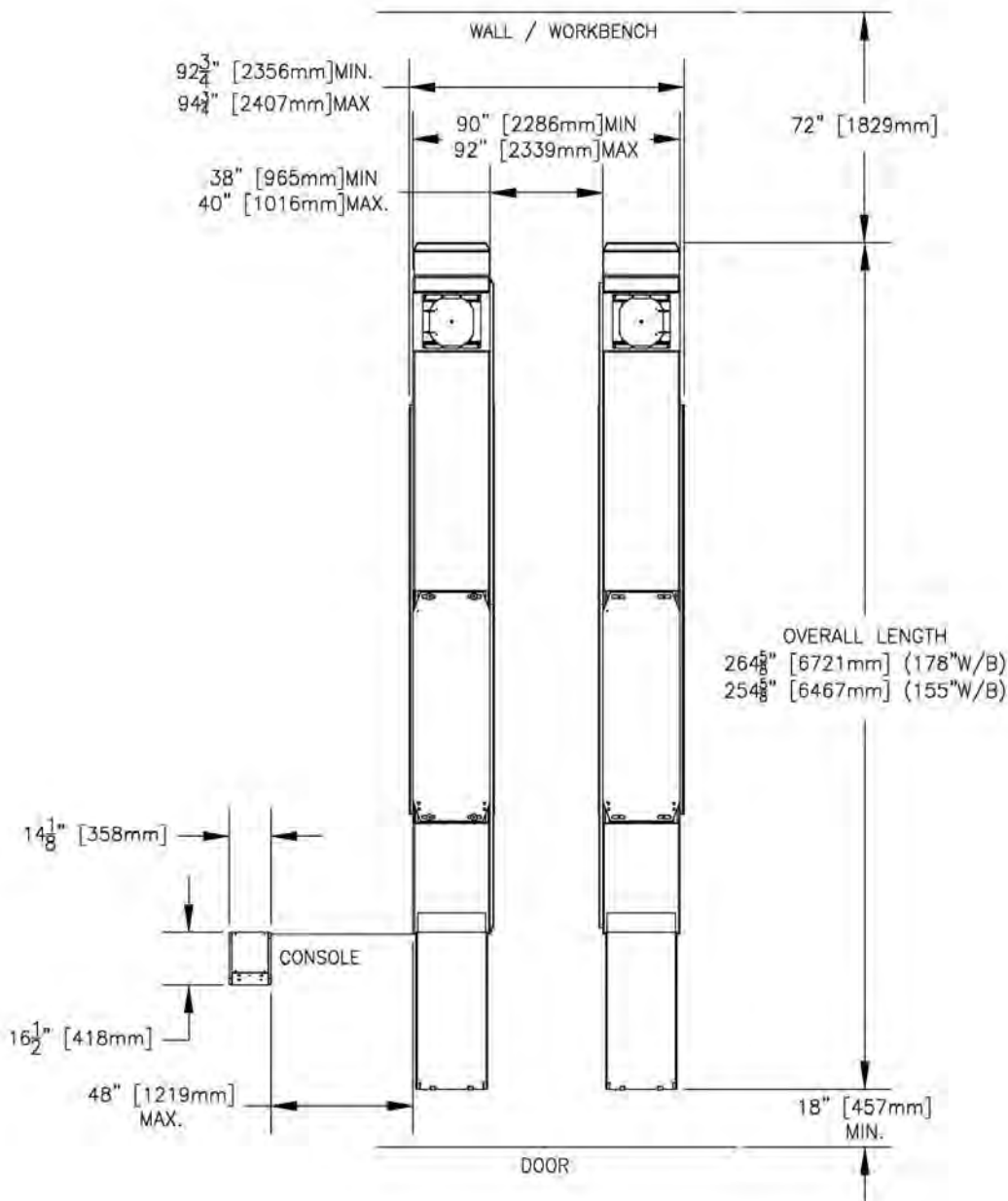

Note: Leave any additional room for any desired aisle or work area.

Recommended clearance around the lift is three (3) feet. Ensure clearance conforms to local building and fire codes.

Recommended overhead clearance is a minimum twelve (12) foot ceiling providing 6 feet for the maximum lift height and 6 feet for the supported vehicle. For vehicles taller than 6 feet it is recommended that the user provides additional overhead clearance or a shut off mechanism to stop the lift from raising the vehicle too high.

Figure 3 - Typical Bay Layout (Surface Mount)

7.3 Baseframe Location

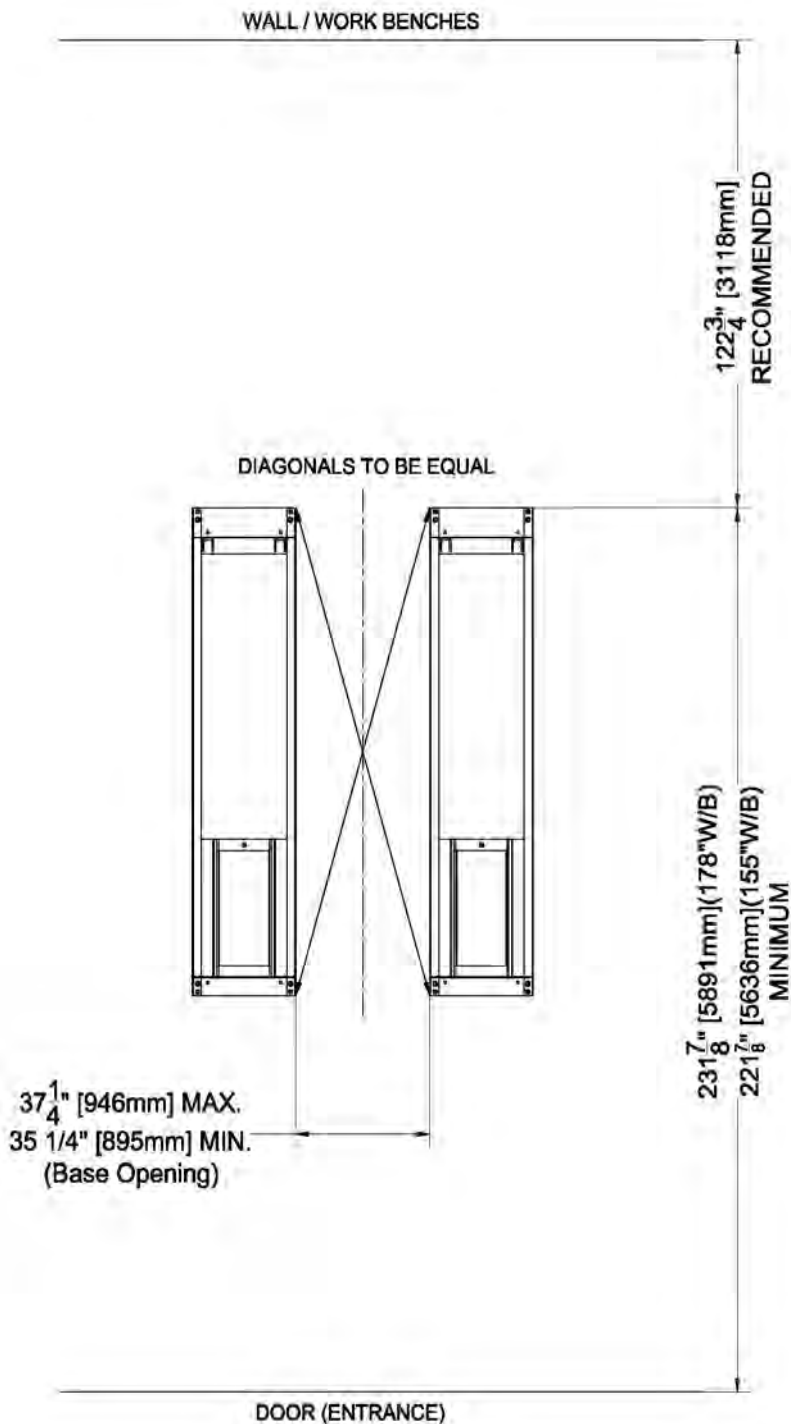

IMPORTANT: DO NOT CUT THE SHIPPING STRAPS HOLDING EACH SCISSOR ASSEMBLY TOGETHER UNTIL INSTRUCTED TO DO SO.

1. With reference to **Figure 3**, the installer should locate the most suitable location in the shop for the lift.
2. Snap a chalk line for the centerline of the lift ensuring that it matches the centerline of the bay door.

*** See Section 6.0 Installation Instructions for the floor surface requirements.**

3. Measure and snap two (2) parallel chalk lines on either side the centerline for the inside edges of the baseframes. Refer to **Figure 4** for the dimensions necessary to provide the desired width between the two runways. A distance of 35-¹/₄" between the baseframes will provide the standard width of 38" between the inside of the runways. This can go to a maximum of 37-¹/₄" to provide 40" between insides of runway.
4. Measure and snap a chalk line parallel to the shop door for the front of the baseframes, a minimum distance of 231-¹/₈" (178"W/B) / 221-¹/₈" (155"W/B) is recommended.
5. Before proceeding, ensure that once the runways are installed adequate workspace will remain in front of the lift.

Figure 4: Baseframe Locations



Refer to the minimum requirements listed in the installation and operation manual of any alignment equipment as needed.

7.4 Unpacking the Lift

1. Unpack the console and place it in the desired location at the rear of the lift. The console can be placed on either the left or right hand side of the lift. The console must be located so the operator is always facing the lift.
2. Unpack the runways and lay each baseframe along the chalk lines.



Do not remove the individual strapping on the runways until they have been positioned on the chalk lines.

3. Position the baseframes on chalk lines, and ensure that the runways are parallel. Ensure that both the inside dimensions (front and back) of the baseframes as well as the diagonal distances are equal.
4. Remove the remaining packing straps, and remove the hydraulic hoses and polytubes from under the runway. Hoses are located under the rear portion of the runway and are factory pre-installed.
5. Inspect lift for damage or any irregularities. If any are found, please contact customer service before proceeding.

Note: Do not pull excessively on the hoses as it may strain the connections to the baseframes.

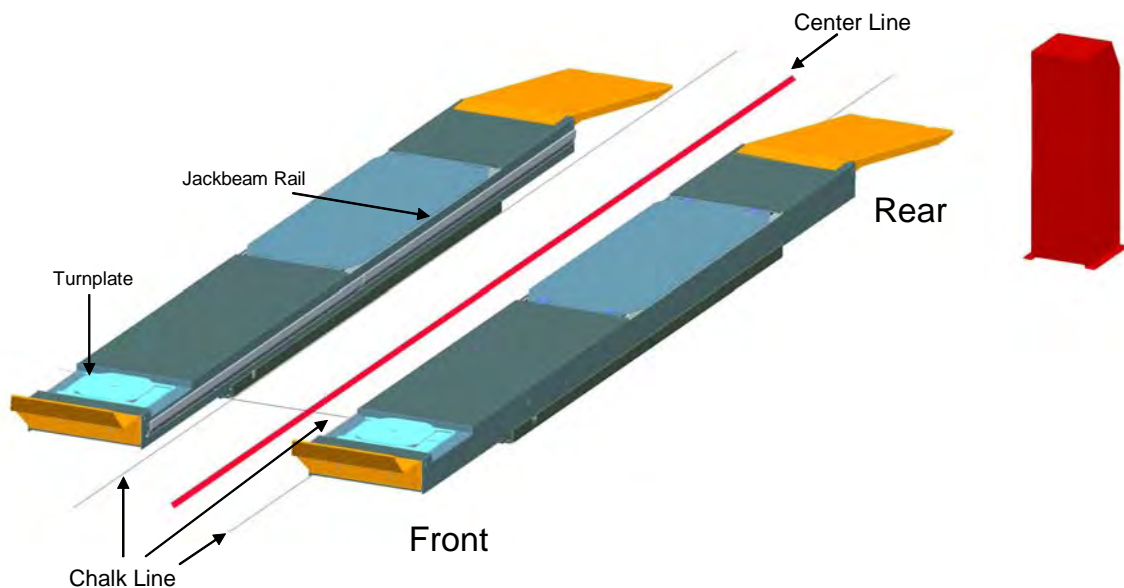

Ensure that the turnplate pockets are at the front, and that Jack Beam rails for each runway face each other.



Ensure there are no holes, depressions, or drains inside the installation area. See Section 6.0 for requirements.

7.5 Hydraulic Connections

1. Open the rear access covers of the console.
2. Unravel all hoses and air lines from each runway and connect the hydraulic lines as shown in **Figure 6**.



- Always make sure that the connections are clean to avoid contaminating the hydraulic system.
- Do not kink hydraulic hoses or air lines.
- Do not remove hydraulic fittings while under pressure..

3. Connect the cylinder hoses (2-2177) to the pump manifold.

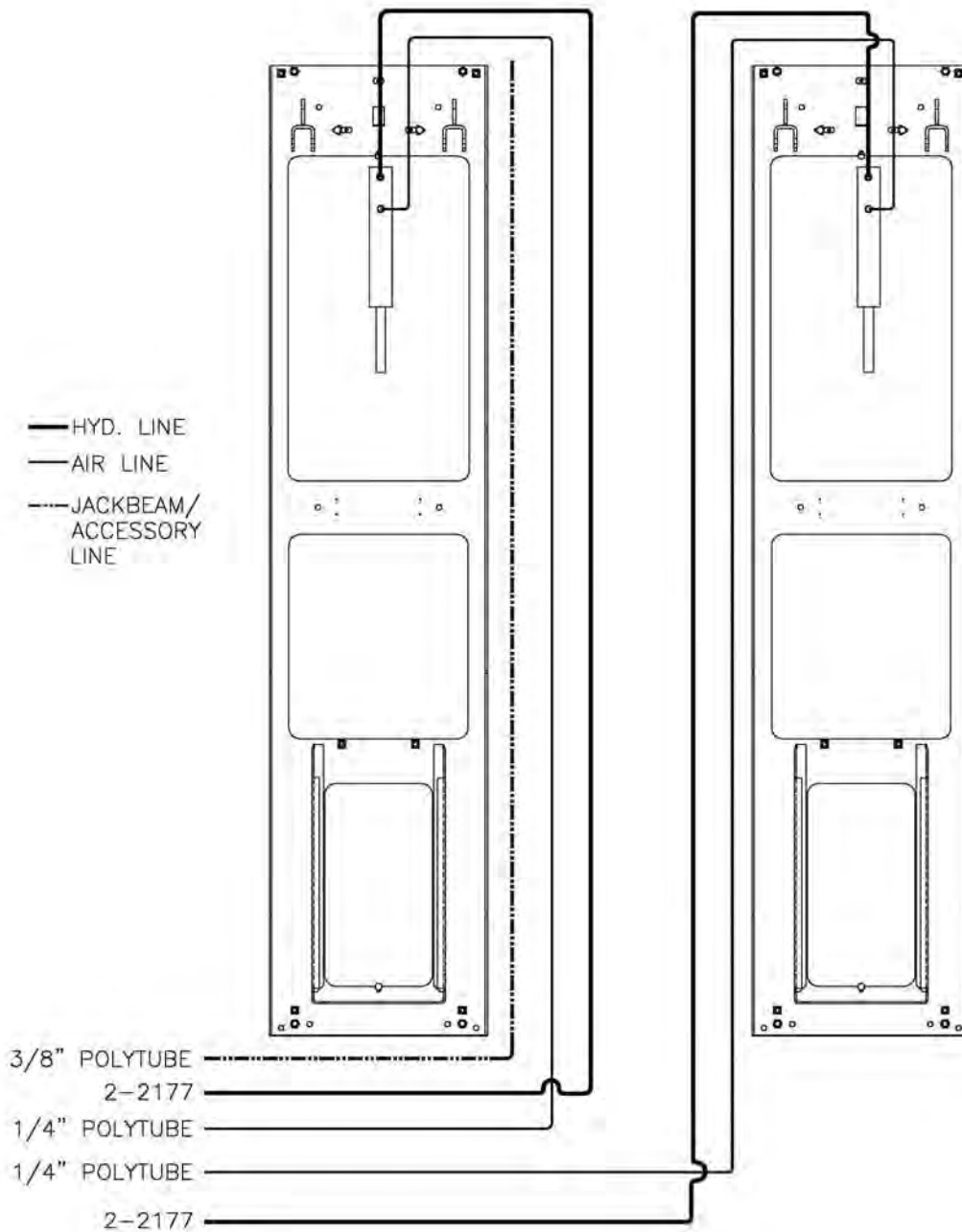

Figure 6 - Air Safety, Auxiliary Air and Hydraulic Connections

7.6 Air Safety and Auxiliary Air Connection



WARNING! WEAR SAFETY GOGGLES AND PRACTICE CAUTION WHILE WORKING WITH COMPRESSED AIR.

1. Uncoil the ¼" polytube under each deck that is connected to the air release cylinder. Cut to desired length and connected to the union "Y" inside the console.
2. Assemble the FRL unit to the side of the console with the hardware provided on the FRL unit. Orient with supply port to the rear of the console and 90° fitting lined up with the hole in the side of the console.
3. Secure the T-fitting inside the console to the 90° fitting on the FRL unit.
4. The 3/8" polytube for the auxiliary air connections is coiled under the right side runway. Route this hose to the console and connect it to the tee fitting at the back of the FRL unit.
5. Connect the compressed air line from the shop to the FRL unit located on the outside of the console.
6. Fill the Lubricator Reservoir with Snap-On Air Motor Oil #IM6 or Equivalent.
 - The console is equipped with an Air Filter / Lubricator / and Regulator to ensure a clean air supply is provided to the safety release cylinders, jackbeams, and any other air tools connected to the lift. The Air Regulator should be set between 90-120 psi.

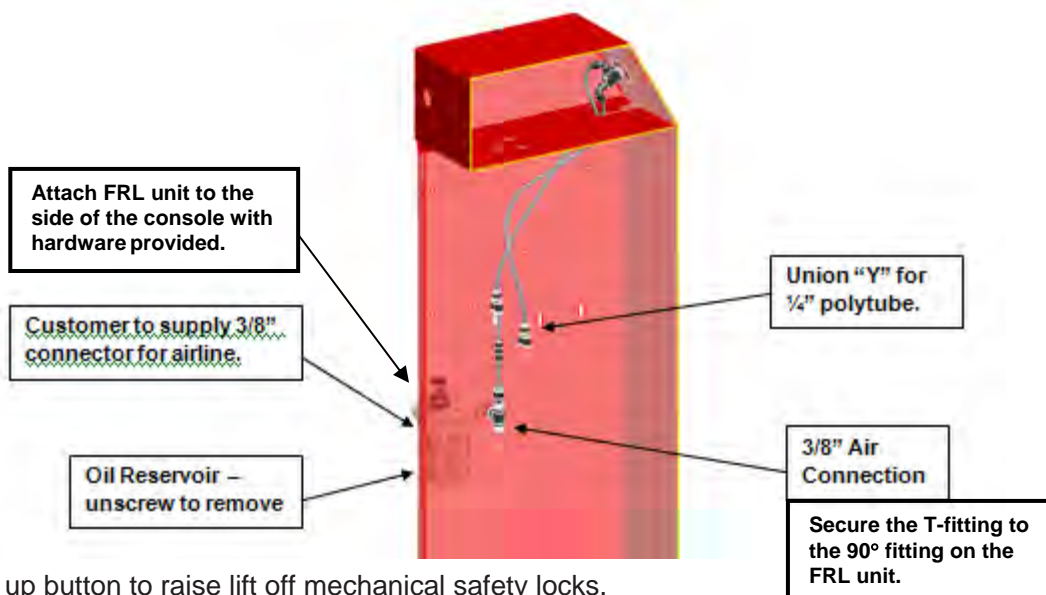

7. Press up button to raise lift off mechanical safety locks.
 - While holding the air safety release button, press the down button and lower the lift completely to the ground.



8. Check the air system for any leaks.

7.7 Electrical Connection



DANGER! ENSURE THAT ELECTRICAL CONNECTIONS ARE COMPLETED BY A LICENSED ELECTRICIAN! ELECTRICAL SHOCKS CAN CAUSE SERIOUS INJURY OR EVEN DEATH.

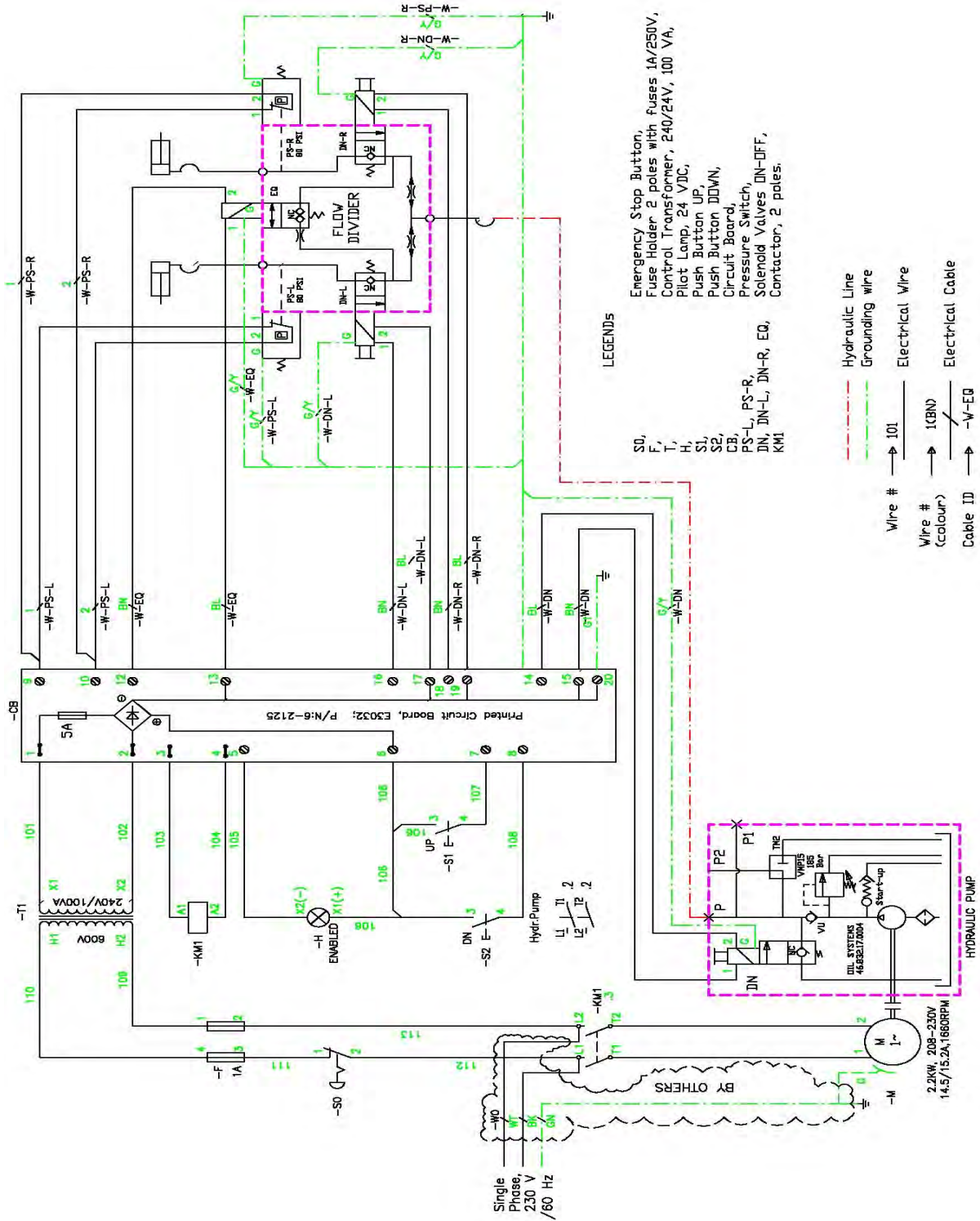

NOTE: Overload fuse does not come with single phase power unit

Figure 5 - Electrical Connections

7.8 Initial Run



IMPORTANT! BEFORE STARTING THIS PROCEDURE, TEMPORARILY SHIM THE KICKER AREA, IF NEEDED. FAILURE TO DO SO WILL CAUSE DAMAGE TO THE LIFT. (SEE DIAGRAM IN SECTION 7.0)

1. Once the main electrical power supply has been connected, remove console top cover. Remove (3) screw completely and loosen the forth until you are able to rotate the cover out of the way.
2. Using a funnel with a screen filter, add 15 liters / 4 gallons hydraulic fluid (refer to **Section 3.0** for recommended type).
3. Turn the potentiometer adjustment fully clockwise.
⤵ **Do not use excessive force to turn screw.**
The potentiometer adjustment is located on the PCB board.
4. Press the UP button until the LED illuminates.
(Approximately 12"-14" high)
5. Press and hold the Safety Release button and the DOWN button simultaneously to lower the lift to the ground, until the green LED light goes off. This will release air from the hydraulic system.

Note: If the LED is not illuminated, the lift will not lower – press the up button and raise the lift until the LED comes on. Once the LED is illuminated, the lift can be lowered.

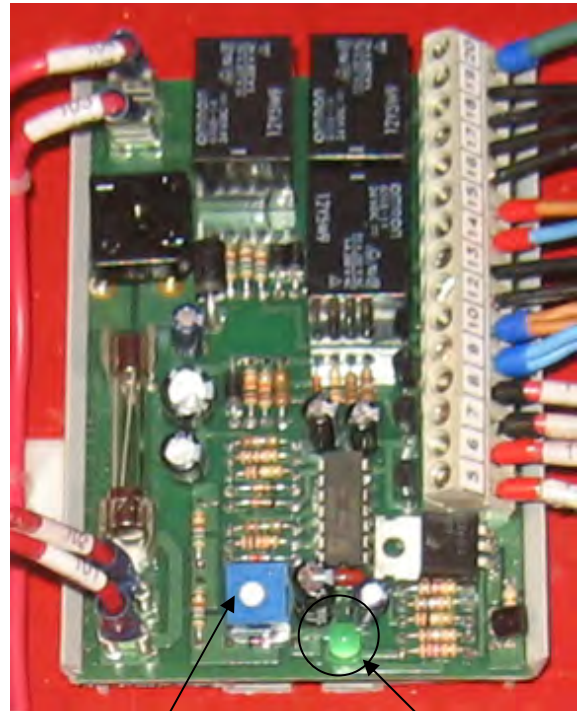

Potentiometer

LED

6. Repeat these steps 5-6 times to completely bleed the system of air. Check the lift for hydraulic leaks at all connections. When complete, turn the potentiometer adjustment fully counter clockwise. ⤴
7. After bleeding, it is recommended that the fitting assemblies located on the flow divider valve, where hydraulic hoses from lift attached be cleaned. **Note: Place the fitting on a workbench and use an air gun to blow through the filter in the opposite direction to flow from the lift.**
8. Reinstall fitting assemblies and connect hydraulic hoses.
9. Reinstall the console top cover.



Fitting Assembly

7.9 Level and Support



NOTICE: CORRECT LEVELING IS IMPORTANT TO ENSURE THE PROPER OPERATION OF THE LIFT. TAKE PRECAUTIONS TO ENSURE ACCURATE LEVEL READINGS WHEN PERFORMING THIS PROCEDURE.

Side-to-side leveling measurements should be taken off the baseframe, and measurements should be taken on each baseframe as well as between the two baseframes. Front-to-back level measurements should be taken on the runways.

1. Press the UP button and raise the lift approximately 3-4 ft off the ground. Check the location of the baseframes compared to **Figure 4**, and make minor adjustments as required.
2. Level the baseframes using the 5/8" leveling bolts provided at each of the four (4) corners.

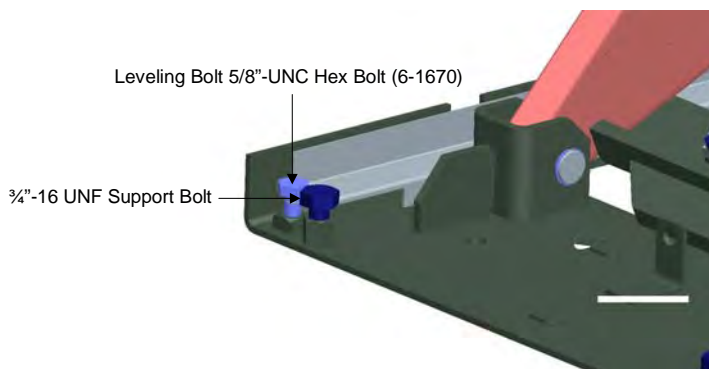

3. Use shims provided to support under glide block area, the kicker area of baseframe and under front hinges. See **Figure 7**.

Note: See section 6.0 Installation Instructions for floor requirements.

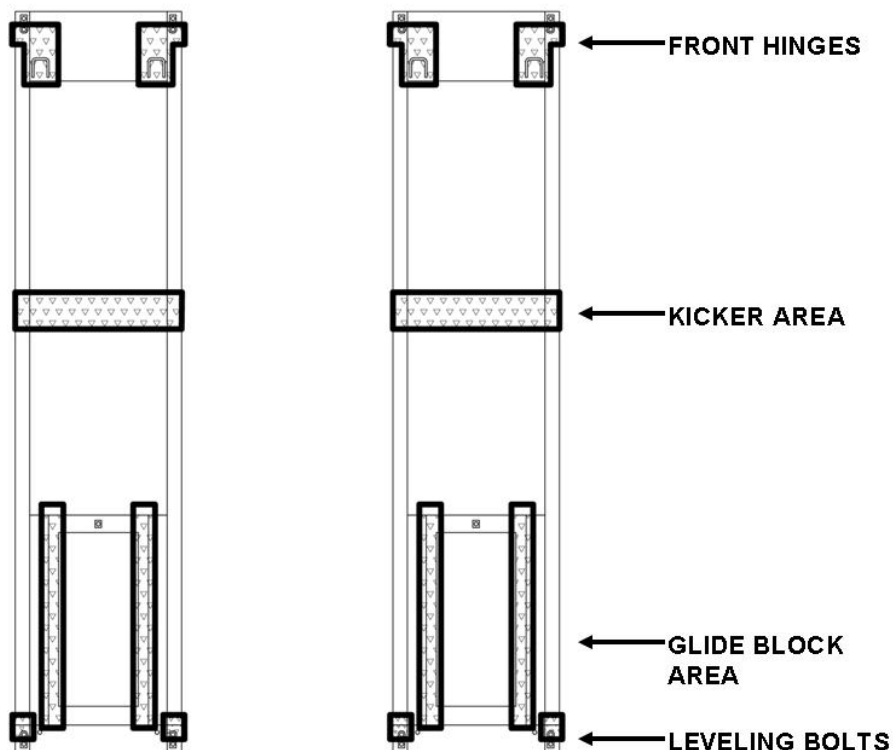
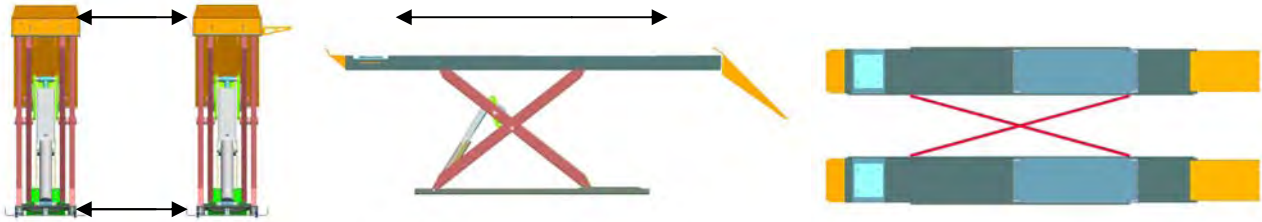

Figure 7 – Shimming

4. Verify that the baseframes are level side-to-side and that the runways are level front-to-back. The front turnplate and rear slip plate are the areas of interest. Check that the spacing between the runways is as desired, and that this spacing is equal at both the front and rear of the lift.



*Check that the diagonal measurements between opposite corners of the baseframes are equal.
Lower and raise the lift and repeat these measurements.

5. Once lift is level, back off 5/8" leveling bolts so that the base is firmly sitting on the shims. Recheck to make sure the lift is still level and shims are holding properly.

Note: These bolts must be removed once the shims are installed under the base correctly.

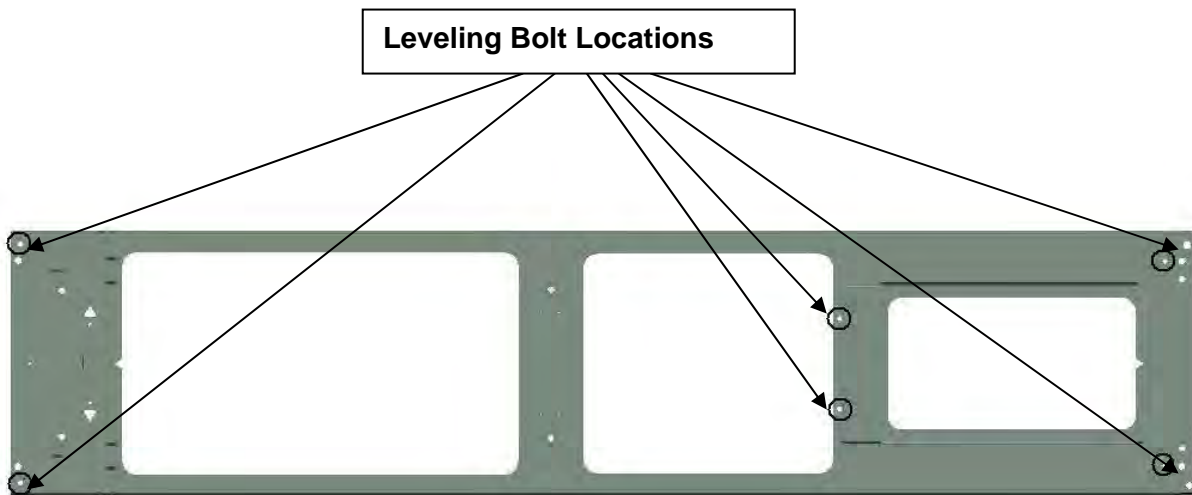

7.10 Anchoring Procedure

1. Lower the lift and measure the distance between the Jackbeam rails at front and rear of the lift.
2. Raise the lift to full height and repeat the measurements, and ensure there are no differences.
3. Using a hammer drill and a 1/2" concrete bit, drill through the floor at each of the six (6) anchor bolt locations on each of the base frames. Make sure that the 1/2" concrete drill bit is in good condition. Refer to **Figure 9** (next page).

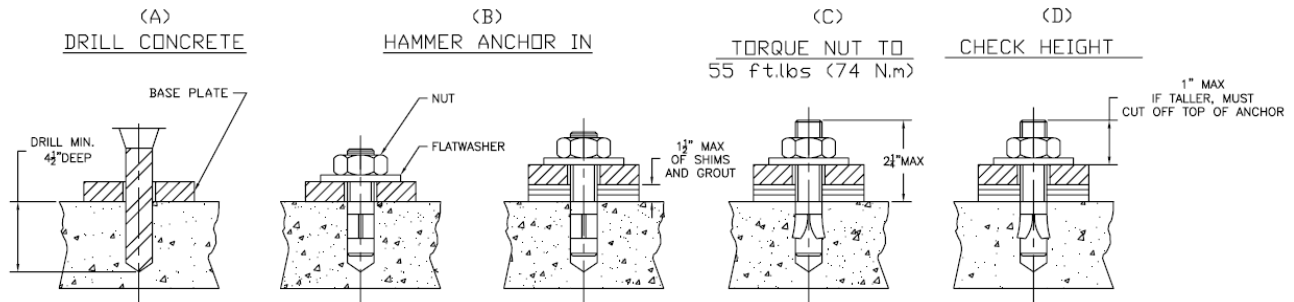

4. Assemble the nuts and washers on the 1/2" x 4 1/2" long wedge anchor bolts supplied ensuring a minimum of six threads are visible below the nut, and hammer in the anchors leaving space for shimming.

NOTE: If more than 1" of the anchor is above ground, the top of the anchor must be trimmed in order for the front cover 22795 to fit.

5. Use shims provided to support around anchor position and hammer anchors until they make contact with the baseplate.
6. Torque all anchor bolts to 40 ft- lbs (54 Nm).

NOTE: The 1/2" x 4 1/2" long wedge anchor bolts supplied must have a maximum of 2 1/4" exposed above the concrete.

NOTE: The wedge anchor must be a minimum of 6 1/8" away from any cracks, edges and joints.

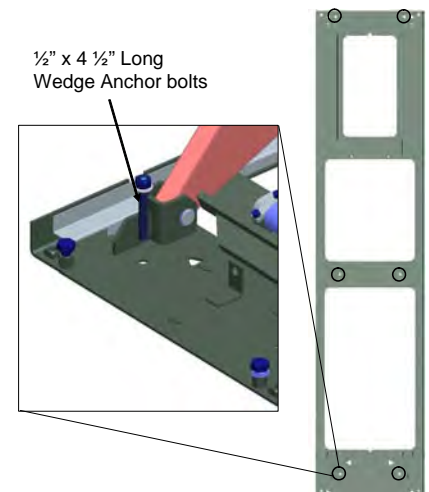

7. Position the console in the final desired location. Refer to **Figure 3**. Using a hammer drill and a 1/4" concrete bit, drill and anchor the console to the floor using the **Nail in Anchors** located in the hardware kit.

8. Check that the 3/4" support bolts on the four (4) corners of the baseframes are adjusted to ensure that the runway is level at fully collapsed position. (9 inches).

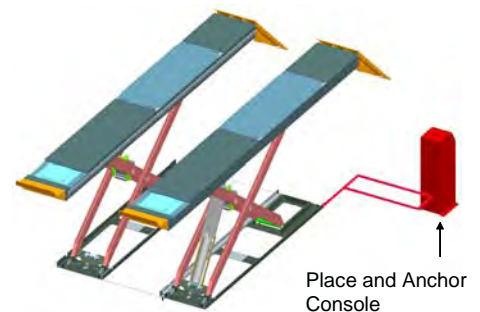
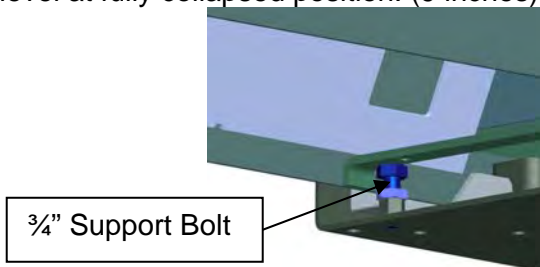

9. Clean kicker area and grease kicker using multipurpose, extreme pressure grease such as Megaplex XD5, NLGI Grade 2 or equivalent. Refer to **Maintenance Section 10.1** for procedure.

7.11 Grouting Procedure (Optional)

1. Pour grouting under the load area of each base frame as shown in **Figure 9**. Ensure that grout is evenly distributed under the frame and finish the edges with a 45 degree chamfer. Refer to specific grouting instructions on the package. Leave a drain area to allow any liquids to escape.
2. **GROUTING MUST FULLY CURE BEFORE PROCEEDING.** Do not operate the lift while grout is curing. Refer to instructions on the package for recommended cure times. [Non-Shrink Grout (3000psi min. in 24hrs, 7000psi min. in 30 days)]

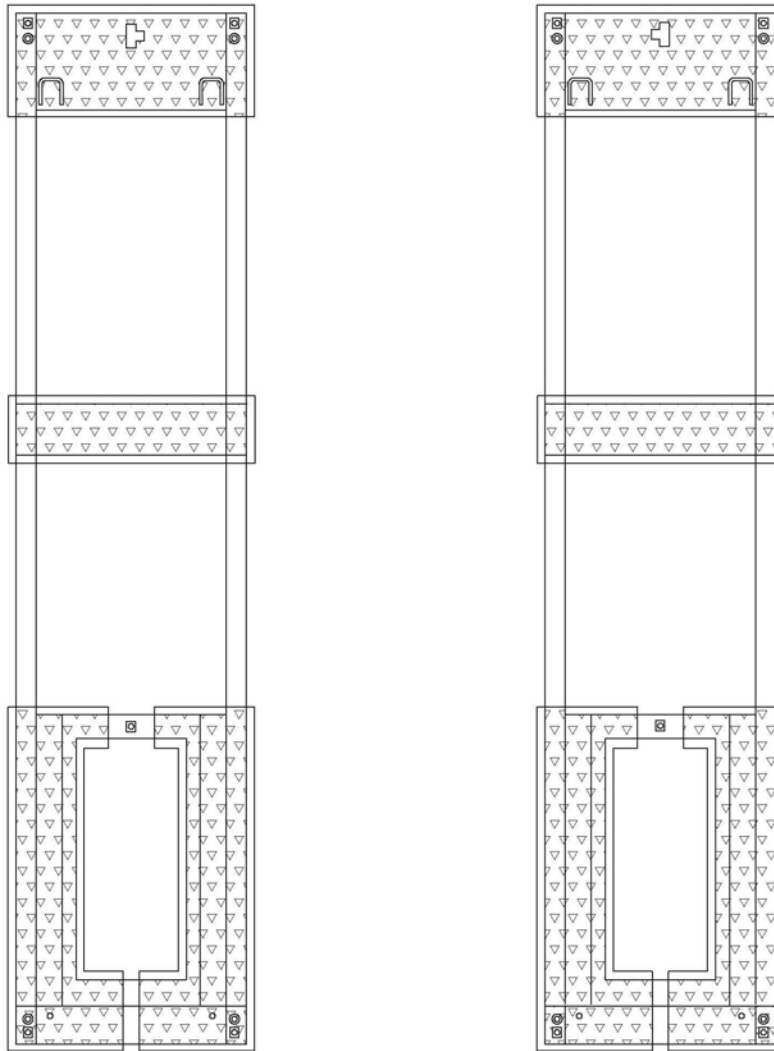
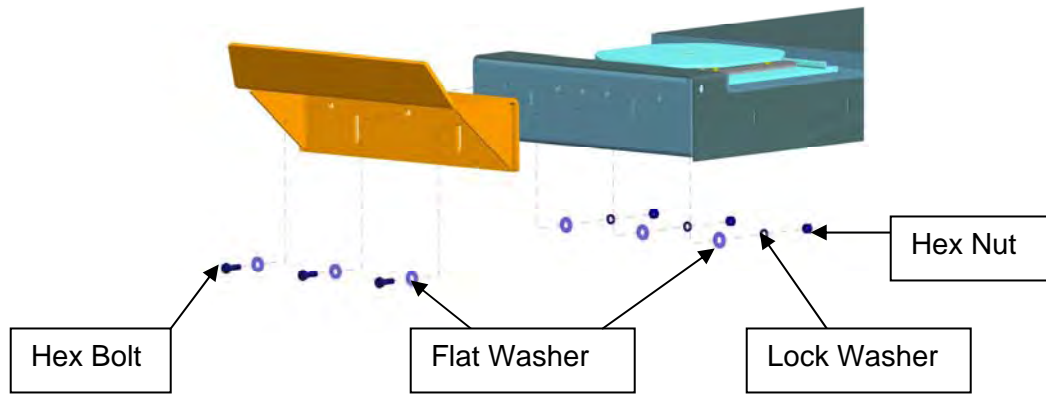

Figure 9 - Grouting Locations

8.0 ACCESSORY INSTALLATION

1. Install the front runway stops located in the accessory box using the ½” hex bolts, washers, lock washers, and hex nuts located in the hardware kit.



The runway stops are designed as a secondary means to restrain a vehicle from inadvertently rolling off the runways. Property damage and physical injuries may occur if this warning is not adhered to.

2. Install the mounting bracket and then the rear approach ramps using the Approach Ramp Pins located in the accessory box, and the hex head bolts, flat washers, lock washers, hex nuts and cotter pins located in the hardware kit.

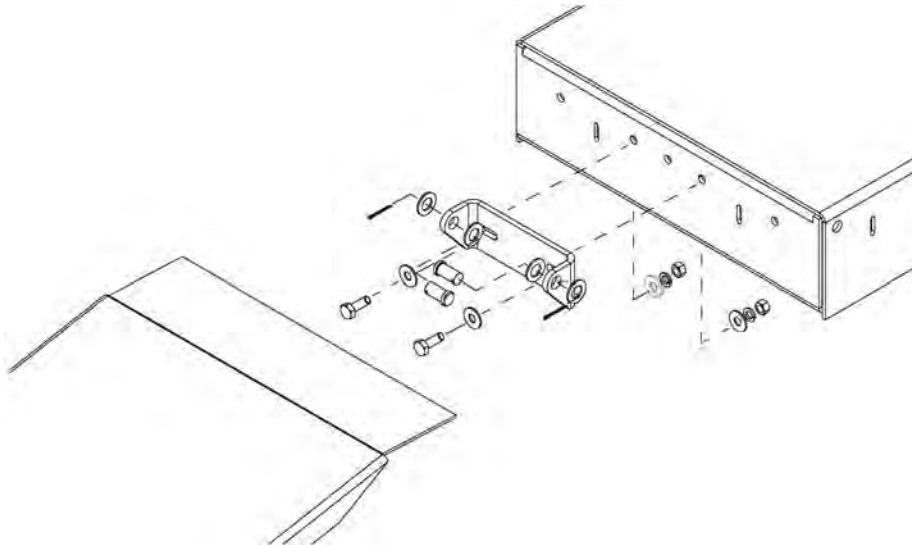

3. Install Jackbeams with reference to the Jackbeam user manual.

4. Position the moveable workstep in the desired location. There are slots along the span of each runway where the workstep can be mounted. When not in use, the workstep can be stored under the front section of the runway.

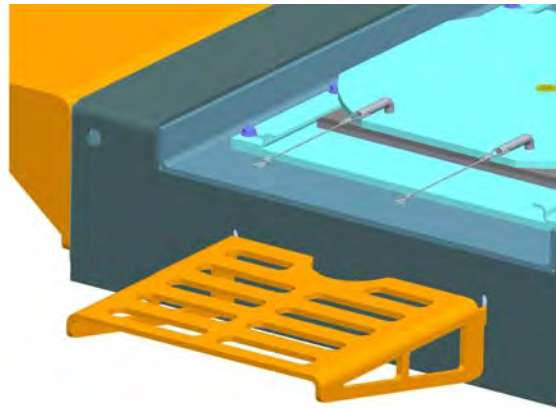

WARNING!! ENSURE THE WORKSTEP IS FULLY ENGAGED PRIOR TO USE. IF MORE THAN ONE WORKSTEP IS IN USE, DO NOT TRY TO STEP ACROSS OR JUMP FROM ONE STEP TO ANOTHER. NEVER USE THE WORKSTEP WHILE THE LIFT IS IN OPERATION. SERIOUS INJURY COULD RESULT FROM IMPROPER USAGE OF THE WORKSTEPS.



WARNING! WORKSTEP MAXIMUM CAPACITY IS 250 LBS.

WARNING! FOR FLUSHMOUNT INSTALLATIONS ENSURE WORKSTEP IS REMOVED BEFORE RAISING OR LOWERING THE LIFT.

8.1 LINE COVER INSTALLATION

1. Install line covers once console is installed and hydraulic lines are routed.
2. Position line cover "C" behind the right baseframe as shown.
3. Cut 11-3/8" off length of line cover "B" and position it behind the left baseframe as shown. Do not discard the cut piece as it will be used in step 4.

Note: It is important to create square cuts. The use of a sliding miter saw or a simple miter box is recommended.

4. Position the line covers "A" between line cover "C" & "B" and mark where they overlap. Cut each to fit.
5. Using the remaining piece of Line cover "B" from step 2, place as shown below.
6. Position line covers "D" to the console. Cut if required.
7. The number along each side of the line covers represents the quantity of fasteners required to secure them in place. Using a 1/4" concrete drill bit, drill holes as required and install the supplied 1/4" x 1" long nail in anchors (6-0141).

Note: Tapcon or equivalent concrete screws can be used as an option for future removal.

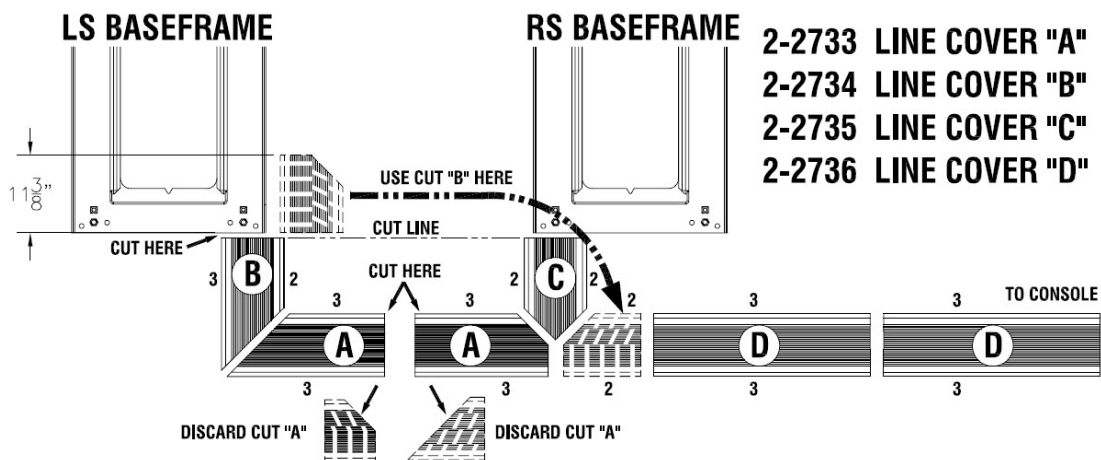

Optional: To locate the consoles on left side of lift, the setup is mirrored with the following changes to the above installation steps:

- Step 3 – use line cover A instead of B.
- Step 4 – use (2) of line cover B.
- Step 5 – use remainder of line cover A from step 3.

Note: If baseframe is shimmed to a point where the line cover does not sit flush due to interference with hoses, the line cover can be heated with a heat gun and then placed over the hoses for a cleaner look.



9.0 LOCKING FRONT TURNPLATES & REAR SLIP PLATES (OPTIONAL)

9.1 Installation of Front Turnplates



Avoid inserting fingers in the front alignment pan cut-out, if position of the turnplate assembly exposes such openings.



Ensure that air supply to the lift is turned off and no person is operating on the console during maintenance of clamping elements of the locking system.



During normal use, the front turnplates and rear slip plates may move rapidly, when locking system is activated. This creates pinch points for your fingers or hands. Keep hands clear of these pinch points when lift air supply is connected. No person shall operate console while maintenance or inspection of the slip plates is in process.

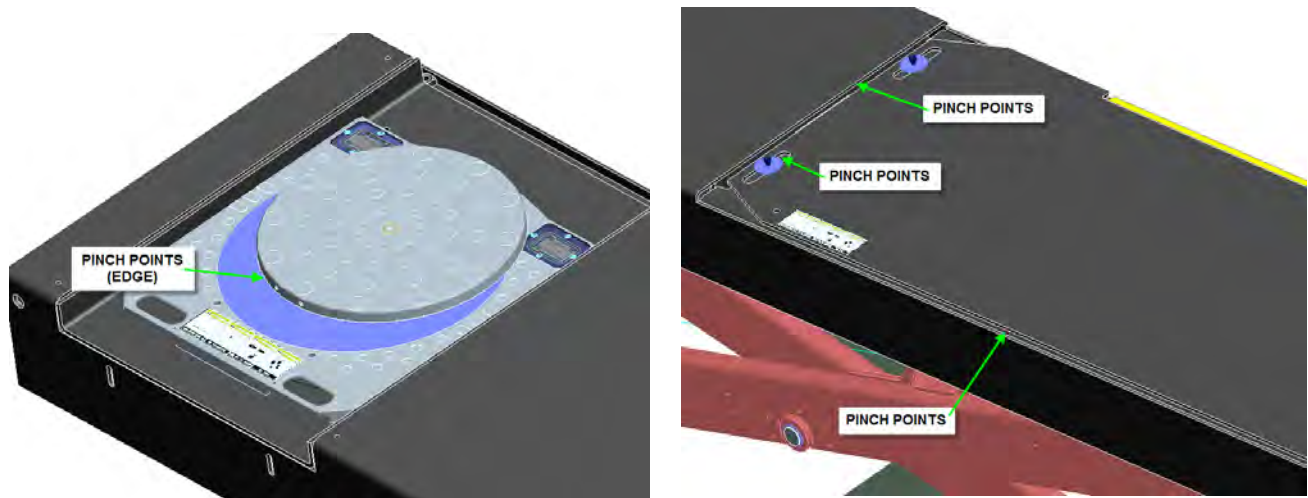

1. Lower lift to a comfort height.
2. Place each front turnplate assembly, one by one, on the front alignment pan on runway. Moving handles of the turn tables should be oriented to the outside of lift [Fig.1].

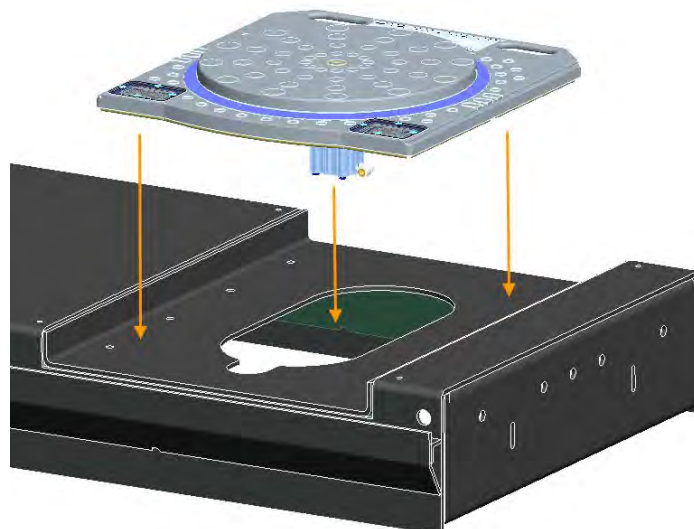

Ensure that the locking system components on the bottom of the turnplate (air cylinder, fittings, and plastic clamping parts) are not hit against the runway during placement.

3. Verify that the turnplate assembly is completely seated in the front alignment pan. Gently slide each turnplate in the alignment pan, left and right, to verify that they can be positioned for different car widths. Do not hit plastic locking ring [Fig.2] forcefully against the edges of the cut-out in the front alignment pan.
4. Connect free ends of front air lines to the turnplate locking cylinder: blue air line to the cylinder port marked with a blue dot and red air line to the cylinder port marked with a red dot [Fig.2].
5. Plug the blue ends of the electrical connector on the turnplate light cord into the electrical connector on the cable at the front [Fig.2].

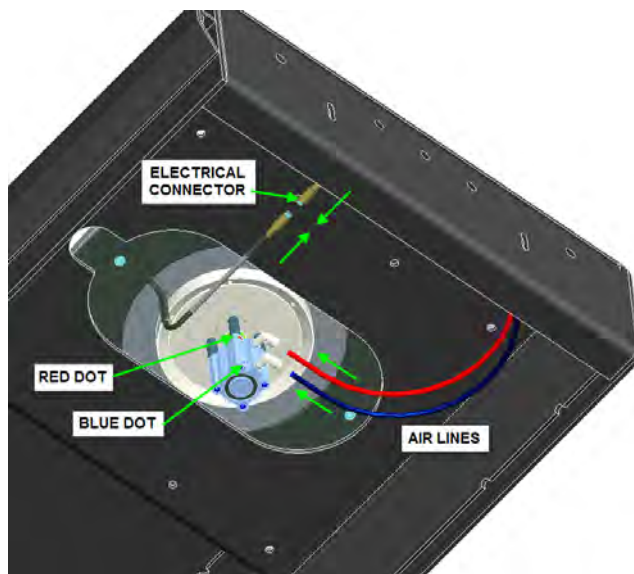

9.2 Console Connections for Locking & Lights

Locking & Light System

1. Connect the (2) red & blue polytubes from lift to corresponding “y” fitting in the console (see Detail C).
2. Connect the 4mm polytube labeled “Return” to pushlock fitting on the LED driver box. Connect the other 4mm polytube labeled “Supply” to the pushlock “Tee” w/ reducer (see Detail “A”)
3. Connect the (2) red & blue female electrical connectors from lift to corresponding red & blue male electrical connectors from the LED driver box (see Detail B).

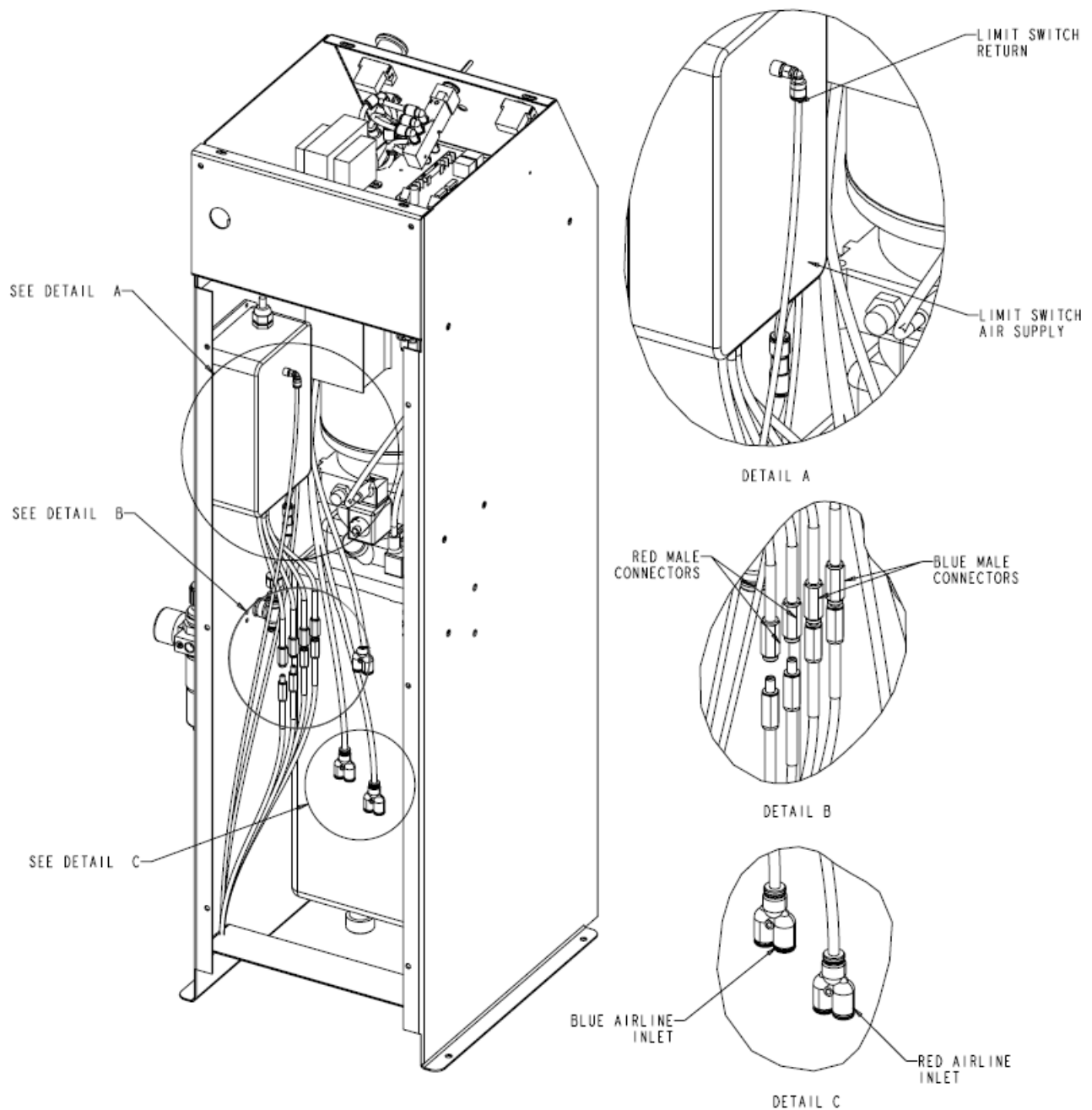

1. Once all connections are made, test system as follows:

- a. **Light System** – **Lift must be fully collapsed.** Start raising lift, at approximately 30” from the ground, the lights will illuminate. If not, please check that the 4mm polytube connections are correct as they may be reversed.
- b. **Locking System** – On front of console, switch the Slip Plate lever to “Unlock”. All locking plates should be free to move, please verify. Now switch the lever to “Lock”, all locking plates should be centered and locked, please verify. If not, check that all polytube connections are correct and there is 90-120 psi of air pressure.

10.0 FINAL PROCEDURES

10.1 Check of Assembled Lift

1. Final dimension check after anchoring. _____
2. Check for air and hydraulic leaks. _____
3. Re-check level of decks, front to rear, side to side. _____
4. Check all fasteners, tighten if necessary. _____
5. Check torque of anchor bolts (Sect. 7.10) _____
6. Operate lift to full stroke then lower to ground while checking
for proper functionality. Ensure Safety Release is operational. _____
7. Ensure Customer Care Kit is complete and given to operator. _____
 - a. Operation Manual _____
 - b. ANSI / ALI Lift It Right Manual _____
 - c. ANSI / ALI Safety Tip Card _____
 - d. ANSI / ALI ALIS Safety Requirements for Installation
and Service of Automotive Lifts _____
 - e. ANSI / ALI Quick Reference Guide _____
8. Ensure Oil has been added to the Filter / Regulator / Lubricator (Sect. 7.6) _____
9. Train end user on operation of lift. _____

10.2 Operation Test with Vehicle

1. Lower lift to the ground. (Make sure Green Light is OFF) _____
2. Drive vehicle on to lift. _____
3. Raise the lift, and lower onto 3-4 different locking positions until the
full lifting height is reached. Check that all locks are working correctly. _____
4. Check lowering speed and smooth decent rate. _____
5. Lower lift to the ground and drive vehicle off lift. _____

If any problems occur during the final checkout or operation of the lift please contact customer service at 1-800-225-5786

11.0 LIFT OPERATION

11.1 Raising the Lift

1. If the lift is equipped with sliding Jack Beam(s), be sure that the Beam(s) are positioned at the front or mid travel of the lift, fully down, and with the risers removed and stored. Never store Jack Beams at the rear of the lift.
2. Ensure that the lift is fully lowered before attempting to load or unload a vehicle.
3. Ensure that locking pins are in the front turnplates and rear slip plates before driving a vehicle onto the lift.
4. Position the vehicle on the lift ensuring the resulting load on the deck is distributed as evenly as possible. Under no circumstances should a vehicle be lifted if the weight distribution is unbalanced by more than 10% on either side.

NOTE: THE VEHICLE IS POSITIONED CORRECTLY WHEN THE DISTANCE FROM THE CENTER OF THE TIRES TO THE INSIDE EDGE OF THE RUNWAYS IS EQUAL ON BOTH RUNWAYS, FOR BOTH THE FRONT AND REAR TIRES.

5. Chock the vehicle using the wheel chocks provided.
6. Check that there are no obstructions above the lift that could damage the lift or vehicles.
7. Raise the lift by pressing the up button on the control console. Raise the lift until the green light is illuminated. (The lift can only be lowered if the green light is on).
8. Lower the lift onto a mechanical safety lock by pressing the down button. Continue to hold the DOWN button until the green light goes off. (Approx. 3-10 seconds)
9. Do not raise or lower the lift with the vehicle on the Jack Beam.



WARNING! NEVER WORK UNDER A VEHICLE OR THE LIFT UNLESS IT IS POSITIONED ON BOTH MECHANICAL SAFETIES!

11.2 Lowering the Lift

NOTE: The lift can only be lowered if the green light is on. If the light is not on, raise the lift until the light turns on. If the lift is at its maximum lifting height, a change in tone may be noticed while raising the lift (This change is the pump working at max relief pressure). Only press the up button until the green light comes on.

1. Lower the vehicle from the Jack beams and remove lift pads and store. If removing the vehicle from the lift, slide Jack Beams to their appropriate position, at the front or mid section of the lift. Check that there are no other obstructions under the lift or vehicle.
2. Raise the lift by pressing the up button until both runways are clear of their mechanical safety locks.
3. Press the air safety release button to release the mechanical safeties.
4. While holding the air safety release button, press the down button and lower the lift to the completely collapsed position.
5. Remove wheel chocks and ensure that locking pins are in the front turnplates and rear slip plates before driving a vehicle off the lift.
6. Be certain that the lift is completely lowered before removing the vehicle from the lift.
7. Do not raise or lower the lift with the vehicle on the Jack Beam.



ATTENTION! THE OPERATOR MUST ALWAYS KEEP THEIR ATTENTION ON THE OPERATION OF THE LIFT WHILE RAISING OR LOWERING. IF AN OBSTRUCTION IS SEEN, RELEASE BOTH THE AIR SAFETY RELEASE BUTTON AND THE DOWN BUTTON TO STOP THE LIFT.

12.0 RECOMMENDED MAINTENANCE

The following maintenance schedule is recommended for ensuring the operation of the lift. A record of maintenance performed should be maintained and any items that resulted in additional service should be noted.

Schedule	Maintenance Required
Daily	Check that the upper and lower glide tracks are clean and free of debris. This area should be checked before raising or lowering the lift.
	Inspect the operation of the lift by raising and lowering the lift fully.
	Check for the proper engagement and release of mechanical safety locks. If bolts are removed for maintenance re-apply LOCTITE #242 before re-assembly
	Check hydraulic lines for leaks and fraying. Frayed hoses must be replaced immediately.
Weekly	Check the fluid level in the reservoir with the lift fully lowered. Top up reservoir with ISO 32 (10 weight) hydraulic oil as needed.
	Check Oil Level in Air Line Lubricator and refill if required (See 11.2)
Monthly	Check anchor bolts for tightness. Torque to 40 ft-lbs if needed.
	Inspect the electrical and mechanical operation of all switches.
	Clean kicker plate and re-grease. See Section 11.1 for procedure and grease requirements. (See Figure 7 for kicker area).
	Inspect runway stop fasteners monthly.
Yearly	Fitting assembly on Flow Divider to be removed and cleaned. See Section 7.8, step 7 for procedure.
5 Year	Change the hydraulic fluid every five years. Use only ISO 32 (10 weight) hydraulic oil.

NOTE: FAILURE TO FOLLOW RECOMMENDATION MAY AFFECT WARRANTY OF LIFT

12.1 Kicker Greasing Procedure

1. Clean both the kicker and the kicker area on the baseframe.
2. Grease kicker using multipurpose, extreme pressure grease such as Megaplex XD5, NLGI Grade 2 or equivalent.
3. Locations to be cleaned and greased are as shown below:

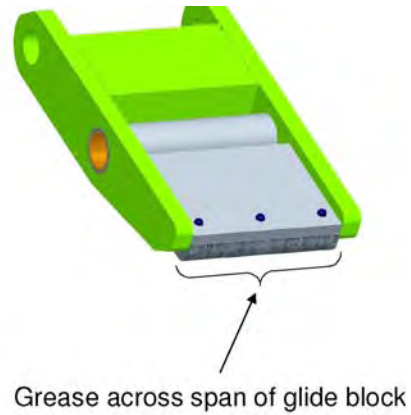
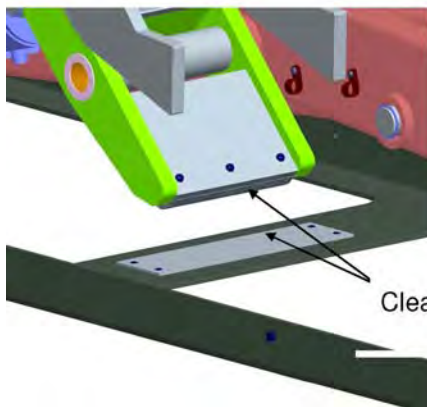

12.2 Checking Oil Level for Air Lubricator

1. The Air Lubricator is located on the outside of the console which allows for easy monitoring of the oil level.
2. If oil level is low:
 - a. Unscrew reservoir from the Lubricator.
 - b. Refill using Snap-On Air Oil #IM6 or equivalent.
 - c. Reinstall reservoir.

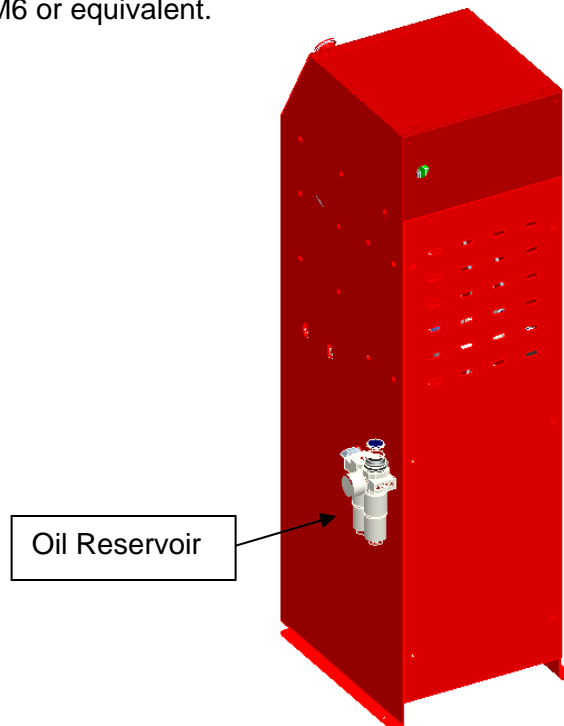

12.3 Maintenance of Turnplate & Slip Plate Locking System (Opt.)

1. Observe locking mechanisms with every lift rise for air line connection integrity. Also ensure that no foreign objects were trapped in the clamping components.
2. Once a week inspect the mating conical surfaces of the front turnplate locking mechanism [Fig.3]. If necessary, blow with compressed air or wipe with a clean cloth any road dust, salt or other contaminants, including liquids. Greasing of these surfaces is not required and not recommended.

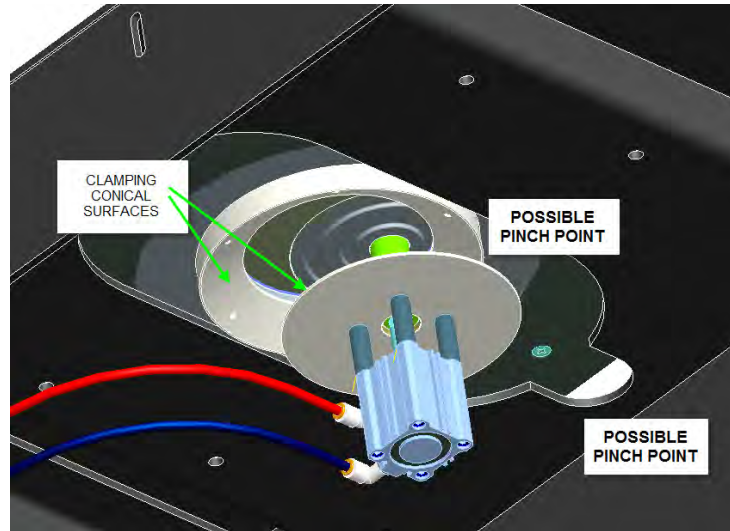

3. After extended use, it may be required that some components of the front turnplate will need replacement, due to normal wear. Please ensure to re-apply *Loctite* where needed, as detailed in the exploded view of the front turnplate [Fig.4].
4. Once a week inspect locking mechanisms of the rear slip plates. Ensure that clamping jaws are securely attached to cylinder clevises and to pivot pins, and that mounting hardware and air fittings are properly fastened.
5. If replacement of rear clamping components becomes necessary after extended use, re-apply *Loctite* to the threads of the rear cylinder shoulder bolts. Exploded view of one set of the 4 rear clamps on the lift is shown in Section 17.2.

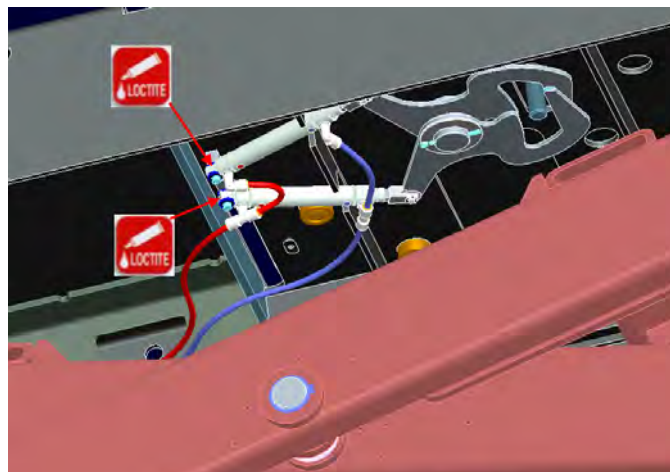

** Re-apply *Loctite* to bolt threads if removing bolts. Tighten shoulder bolts completely in their sockets

12.4 Adjustment of Safety Locks

1. Loosen all the bolts with an 9/16" open wrench

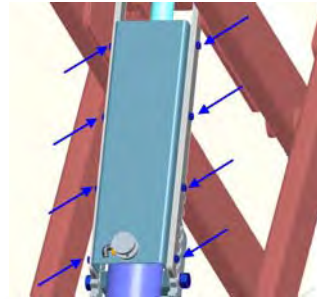

2. Raise lift the lift to its highest position

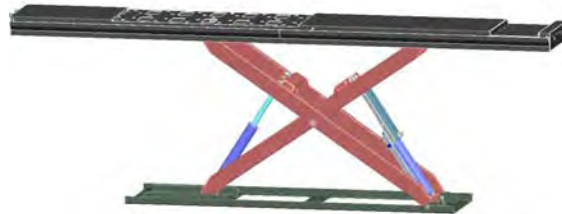

3. Center the top safety rack in between the bottom safety rack.

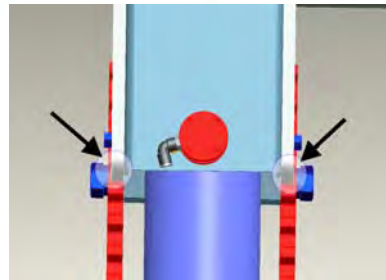

4. Tighten each bolt in sequence as shown in the figure below. Check the alignment after tightening each bolt.

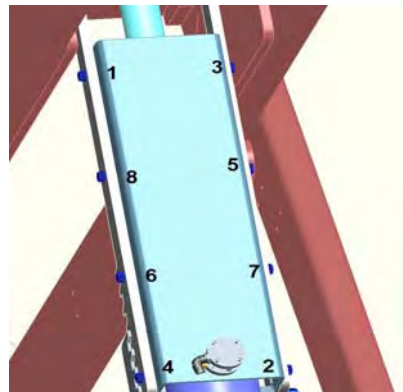

6. Raise the lift and then lower it down, and visually inspect to make sure the adjustment is even. If the adjustment is not even, follow each step again until safety locks touch evenly.

12.5 Maintenance Schedule

Records of all lift maintenance and operator training should be recorded in the following table.

Maintenance and Training Performed	Date	By	Notes

13.0 TROUBLE SHOOTING

PROBLEM	REASON	SOLUTION
Motor does no turn.	Bad fuse or circuit breaker.	Re place fuse or reset breaker.
	Incorrect voltage to motor.	Provide proper voltage to motor.
	Incorrect wiring.	Have certified electrician check
	Motor switch is malfunctioning	Replace motor switch.
	Motor burned out	Re place motor.
Motor runs but lift doesn't go up .	L ow oil level	Fill reservoir with proper hydraulic oil.
	Wrong rotation	Check for oil flow & reverse electrical leads
Lift doesn't come down.	Dirt in hydraulic lines	*Secure vehicle on lift, and clean hydraulic lines.
	Check power to hydraulic lines	
	No power to solenoids	Check power to solenoids
Safety doesn't disengage .	Lift not raised high enough for disengagement	Press Up button for longer period of time .
	Air not supplied to air cylinder	Check if supply line has air.
	Air cylinder malfunctioning	Replace air cylinder.
Lift goes up un-level.	Flow-divider defective	Reverse hydraulic connections
	Blockage in hydraulic hose	Remove & inspect flow through line
Anchor Bolts do not stay tight	Holes are to large.	Relocate lift using proper drill Size.
	Incorrect concrete floor specification. (Thickness and Strength)	Concrete should be replaced by an appropriate concrete pad . (Consult Product Manufacturer / Supplier for further details)
Noise	Squeaking noise during first few inches o f rise	Clean kicker and area. Grease kicker (see Section 11.1 for Greasing Procedure)

14.0 LIFT ASSEMBLY

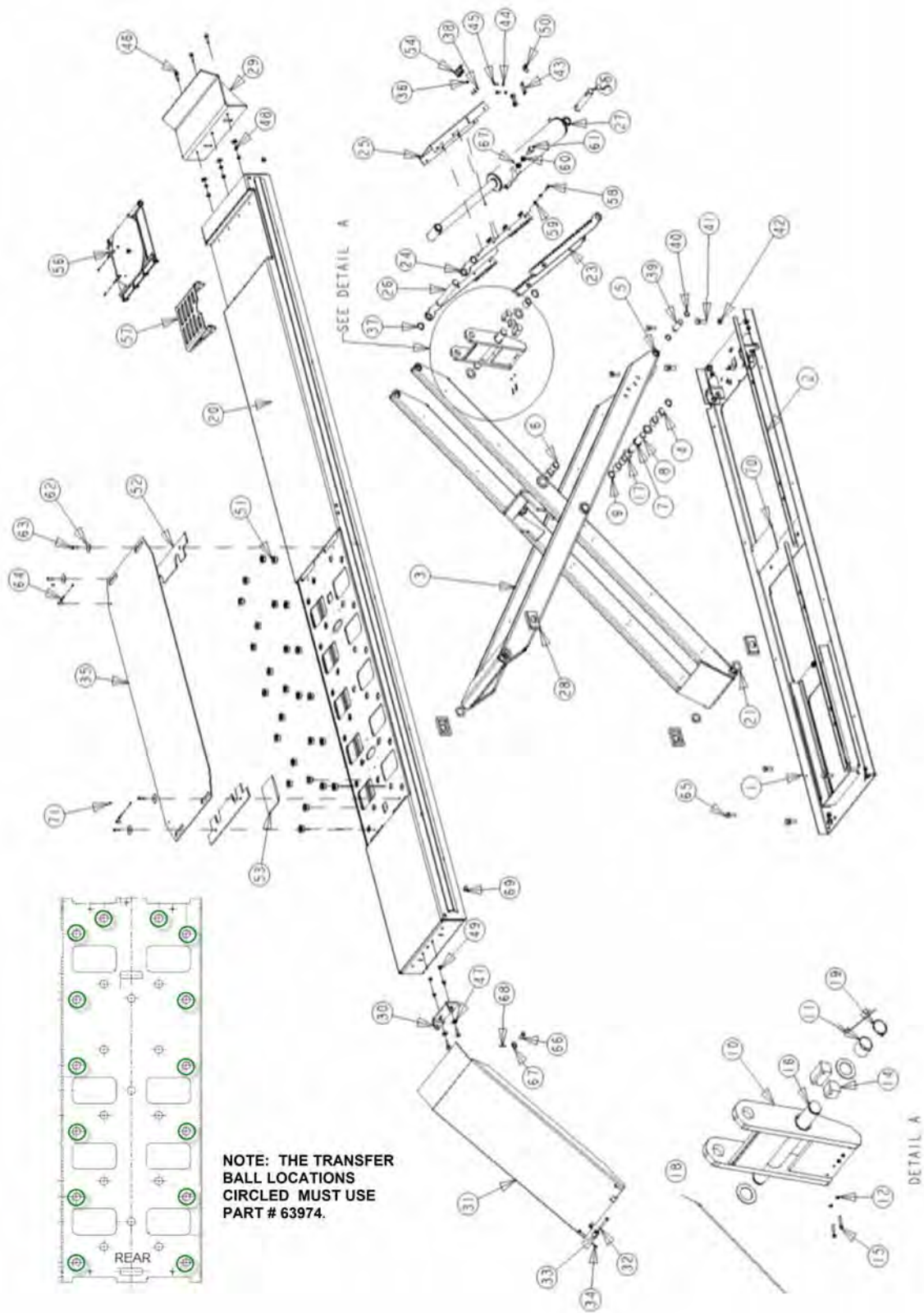

NOTE: THE TRANSFER BALL LOCATIONS CIRCLED MUST USE PART # 63974.

14.1 Lift Parts List

Item#	Part #	Description	Qty.
1	3-0978	BASEFRAME WELDMENT	1
2	2-2301	BASE FRAME COVER (L)	2
3	2-2599	SCISSOR ASSEMBLY	1
4	6-2899	BUSHING, PIVOT, 1-1/2" ID, 24TH24	2
5	6-3087	BUSHING 1-1/4"	2
6	6-3419	1-5/8 SELF-LUBRICATING BUSHING, 26TH24	2
7	1-2795	SCISSOR SPACER	2
8	1-2791	SCISSOR PIN	2
9	6-0233	SNAP RING, #5100-150	4
10	2-2470	KICKER ASSEMBLY	1
11	1-3284	Scissor spacer 10K	2
12	6-0816	Flat Washer, #10	5
14	1-3223	BEARING BLOCK, INNER	1
15	6-1523	SCREW, #10 X 1-1/2, SELF-TAP	5
16	1-3185	KICKER PIVOT PIN	1
17	1-0757	NYLON THRUST WASHER	4
18	1-3171	THRUST WASHER	8
19	6-3418	SNAP RING, #5100-163	2
20	4-1181	DECK WELDMENT, LH (173")	1
	4-1191	DECK WELDMENT, RH (173")	1
	41274	DECK WELDMENT, LH (173") – LOCKING & LIGHTS OPTION	1
	41273	DECK WELDMENT, RH (173") – LOCKING & LIGHTS OPTION	1
	4-1227	DECK WELDMENT, LH (155")	1
	4-1228	DECK WELDMENT, RH (155")	1
	4-1282	DECK WELDMENT, LH (155") – LOCKING & LIGHTS OPTION	1
	4-1281	DECK WELDMENT, RH (155") – LOCKING & LIGHTS OPTION	1
21	1-3171	THRUST WASHER	4
23	2-2111	SAFETY BAR BOTTOM (LASER CUT)	2
24	2-2112	SAFETY BAR, TOP (LASER CUT)	2
25	2-2183	SCISSOR SAFETY COVER	1
26	1-3186	KICKER CLEVIS PIN	1
27	4-1171	CYLINDER ASSEMBLY	1
28	2-2725	SLIDER BLOCK	4
29	2-2117	WHEELSTOP WELDMENT	1
30	1-3159	ADAPTOR PLATE	1
31	3-0905	APPROACH RAMP ASSEMBLY (SURFACE MOUNT)	1
	3-0698	APPROACH RAMP ASSEMBLY (FLUSH MOUNT)	1
32	1-1099	CLEVIS PIN	2
33	1-3062	RAMP ROLLER	2
34	6-0267	Cotter Pin, 1/8" Dia. x 1" LG.	2
35	2-2505	REAR SLIP PLATE	1
	2-2721	REAR SLIP PLATE WELDMENT – LS (LOCKING & LIGHTS)	1
	2-2740	REAR SLIP PLATE WELDMENT – RS (LOCKING & LIGHTS)	1
36	2-1733	ROD END	1
37	6-0233	SNAP RING, #5100-150	2
38	6-2281	PHILIPS SCREW #6	4
39	1-2788	HINGE PIN	2
40	6-0340	CIRCLIP TRU-ARC #5100-125	4
41	6-2936	HEX HEAD GR5 BOLT, 3/4-16 UNF X 1-1/2 LG	4
42	80259000	HEX JAM NUT, 3/4"-NF	4

43	1-2793	CYLINDER RETAINER	2
44	6-0058	LOCK WASHER, 3/8"	12
45	6-0067	HEX BOLT, 3/8" NC X 1" LG	4
46	6-0291	Hex Bolt, 1/2"-13UNC X 1 1/2 LG.	5
47	6-0063	Flat Washer, 1/2"	5
48	6-0059	Lock Washer, 1/2"	5
49	6-0035	NUT, 1/2-13 UNC, HEX	5
50	6-2956	90 HYD ELBOW VELOCITY FUSE 4GPM	1
51	6-2940	BALL BEARINGS, INTERIOR	13
	6-3974	BALL BEARINGS, PERIMETER	14
52	1-3033	SLIDER PLATE	2
53	1-3032	SLIDER PLATE INSERT	10
54	3-0812	AIR CYLINDER ASSEMBLY	1
55	1-2789	CYLINDER PIN	1
57	2-2119	WORKSTEP	1
58	6-0666	HEX BOLT 3/8 UNC X 1-1/4 LG, GR8	8
59	6-0034	HEX NUT, 3/8" NC	8
60	6-0259	LOCK WASHER, 3/4	2
61	6-2936	HHCS, 3/4-16 UNF X 1-1/2 LG	2
62	6-0426	FLAT WASHER	4
63	6-0206	Shoulder Bolt, 3/8" DIA. X 1" LG.	4
64	2-0637	LOCKING PIN ASSEMBLY	2
65	6-1670	HEX BOLT GR5, 5/8"-NC x 2" LG	6
66	1-1887	HEADED PIN	2
67	6-0738	FLAT WASHER 3/4" SAE	6
68	6-0978	Cotter Pin, 1/8" DIA. X 1 1/2" LG.	2
70	2-2409	WEAR PLATE	1
71	6-1134	SELF TAPPING SCREW, #12 X 1/2" LG	4
72	1-1384	TUBE END COVER	2

OPTIONS

56

TURNPLATE ASSEMBLY

- Contact your local sales personnel for part number and cost.

*** NOTE: QUANTITIES LISTED ARE ONLY FOR SINGLE SIDE.**

- LEFT SIDE ASS'Y #4-1192
- RIGHT SIDE ASS'Y #4-1193

OPPOSITE SIDES ARE SYMMETRICAL

15.0 HYDRAULIC/AIR PARTS ASSEMBLY

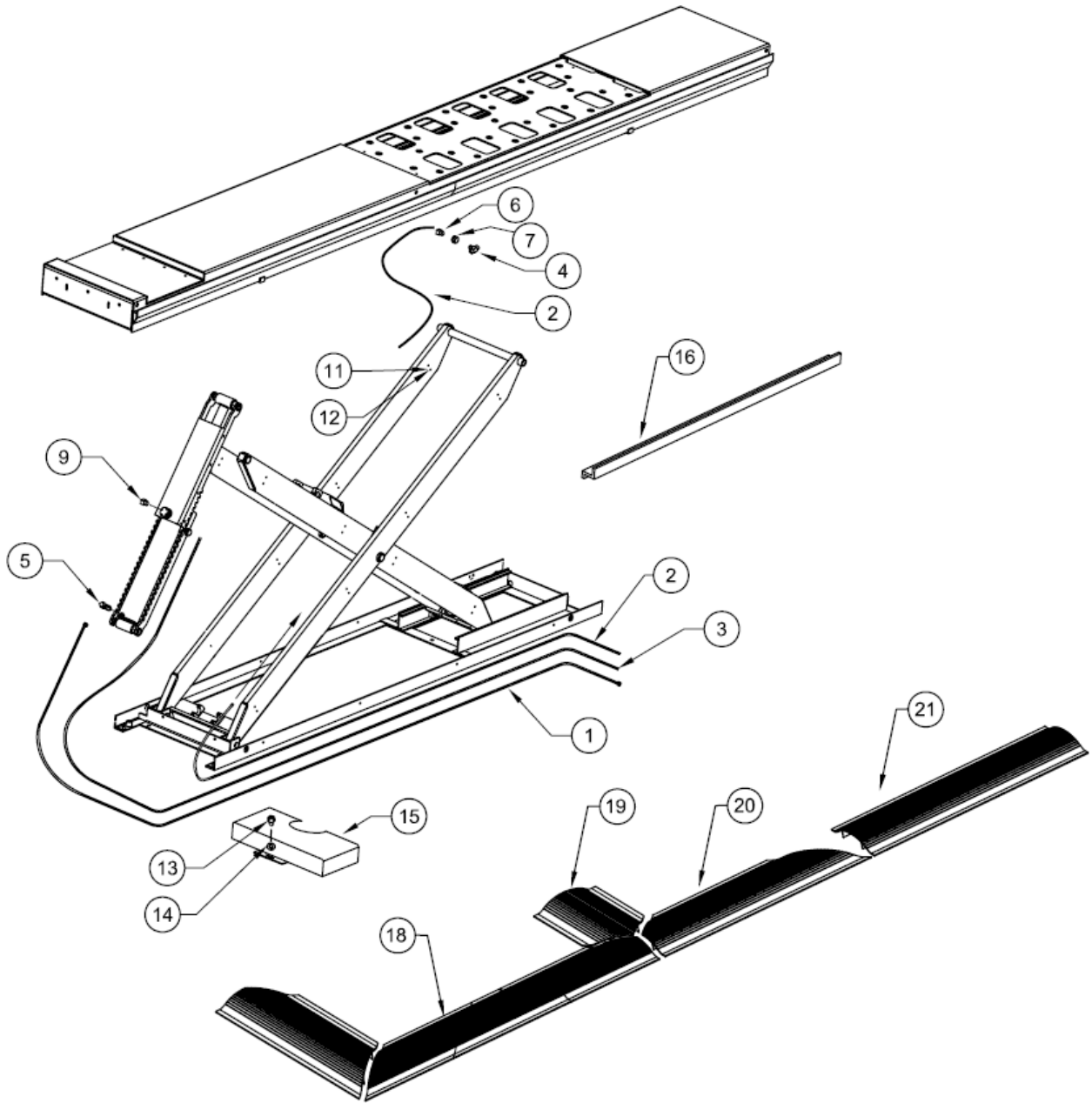

15.1 Hydraulic/Air Parts List

Item	Part #	Description	Qty
1	2-2717	3/8" Hydraulic Hose	2
2	6-3019	3/8" Polytube, 480" LG	1
3	6-3020	1/4" Air Hose, 350" LG	2
4	6-3896	Branch Tee Fitting ¼ NPT, F-F-M	1
5	6-2956	Velocity Fuse	2
6	6-3010	90 DEG Elbow, 1/4" NPT-M, 3/8" Polytube	1
7	6-0167	Terminal Bolt, 3/4"	1
9	6-0709	90 DEG Elbow, 1/8" NPT, 1/4" Polytube	2
11	6-0170	Pipe Clamp, 3/8"	8
12	6-1134	Self Threading Screw	8
13	6-0178	1/4" Hex HD Bolt x 3/4"	6
14	6-0060	1/4" SAE, Flat Washer	6
15	2-2795	Front Cover	2
16	2-2519	Baseframe, Line Cover	1
17	2-2520	Baseframe, Line Cover	1
18	2-2733	Floor Line Cover "A"	2
19	2-2735	Floor Line Cover "C"	1
20	2-2734	Floor Line Cover "B"	2
21	2-2736	Floor Line Cover "D"	2
	6-0141	Nail-in Anchors, ¼" x 1" Lg.	37

16.0 Accessory assembly

16.1 Front Turnplate

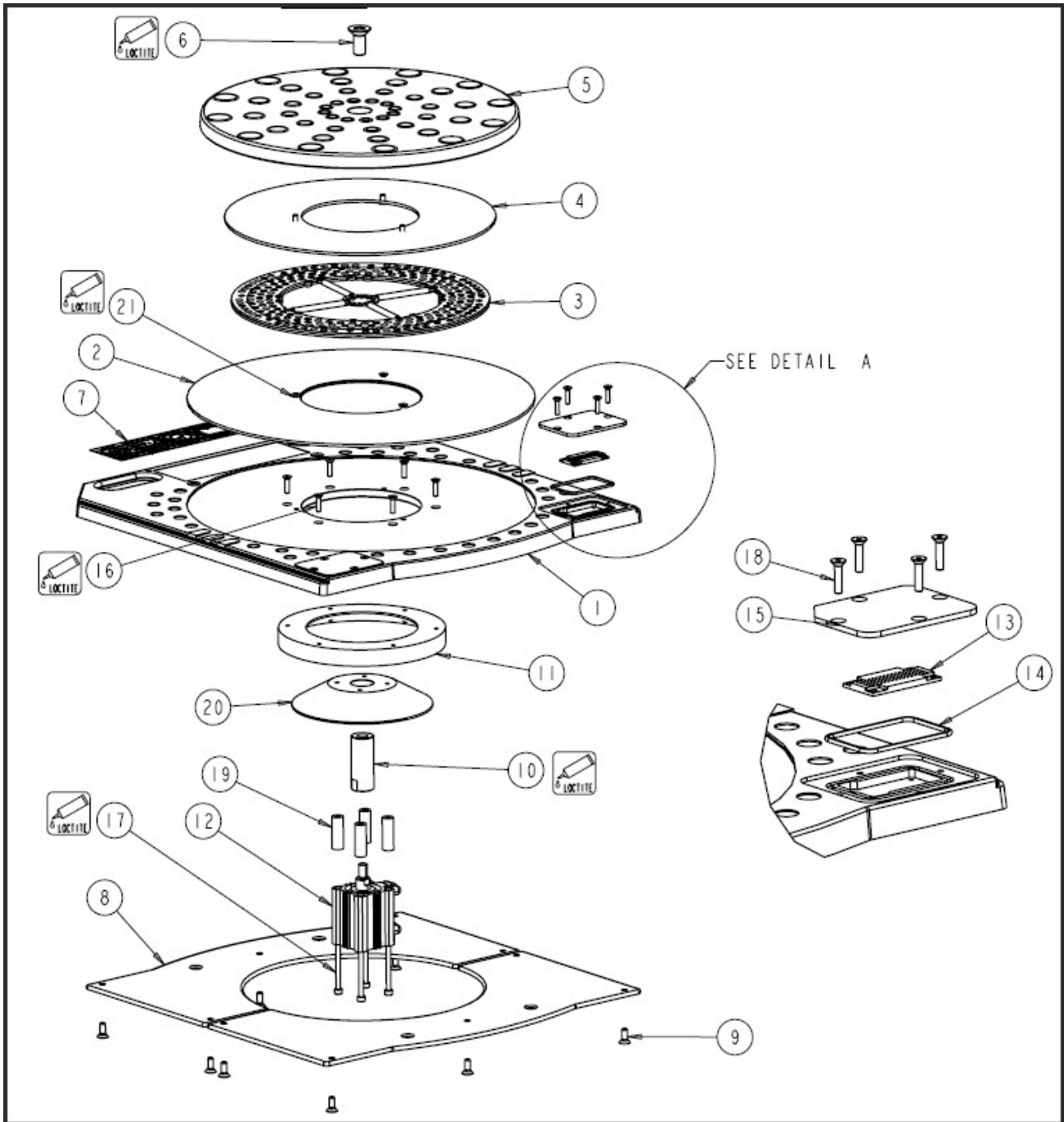

TURNPLATE ASSEMBLY: PARTS LIST

Item #	Part #	Description	Qty.
1	2-2727 **	Turnplate Assembly (Complete)	1
2	EAM0047J58A	Bottom Wear Plate	1
4	EAM0047J57A	Wear Plate, Top	1
5	EAM0047J60A	Turnplate Top	1
7	1-3719	Label	1
8	EAM0047J52A	Wear Pad, Bottom	10
10	1-3678	Stub Shaft	1
11	2-2711	Centering Ring	1
12	6-3899	Locking Cylinder Assembly	1
13	6-3912	LED Light Pad	2
14	6-3906	O-Ring Seal	2
15	1-3682	Plastic Lens Cover	2
16	6-3904	FHCS, #10-32 UNF x ¾", SS	6
17	6-3902	SHCS, M5-0.8 x 120mm Lg	4
18	6-3903	FHCS, #8-32 UNC x ¾", SS	8
19	1-3677	Cylinder Stand-off	4
20	2-2709	Centering Cone	1
22	6-3925*	Cable Assembly, LED light (not shown)	1

* Not shown

** Must include in order 1 x EAK0289J05A with every order of 22727.

Note: Please contact customer service for items not listed.

16.2 Rear Slip Plate Locking Mechanism

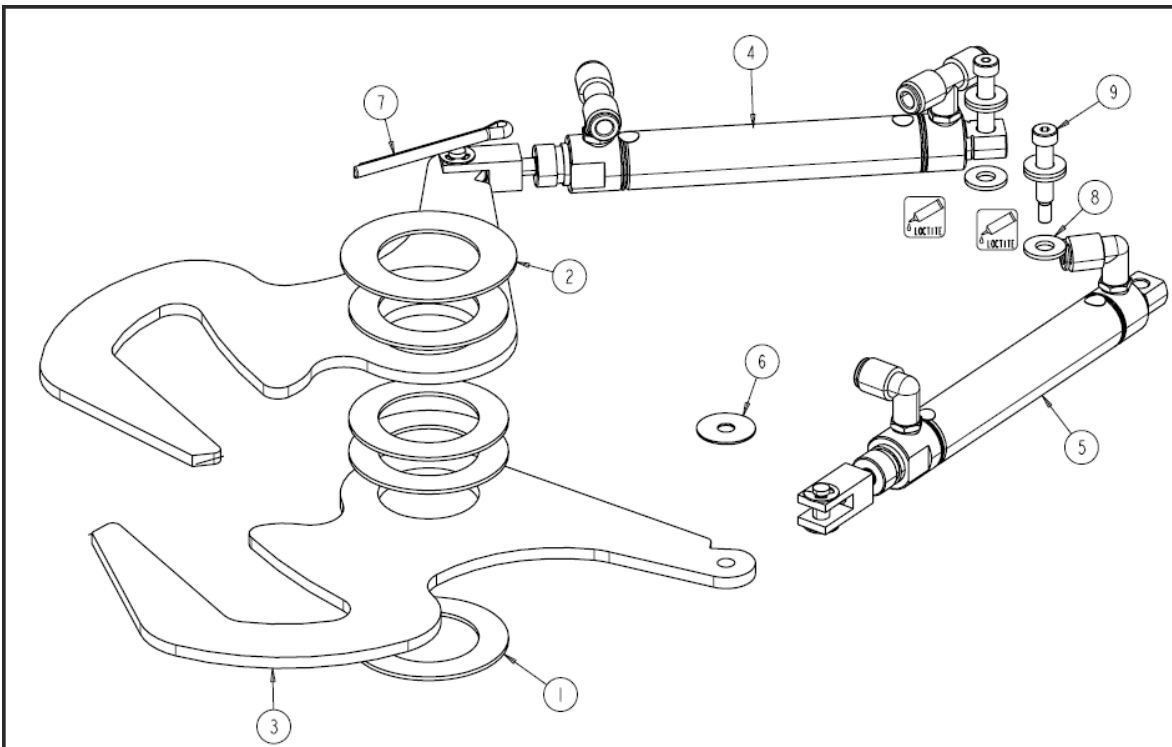

Item #	Part #	Description	Qty.
1	1-0757	Nylon Thrust Washer	4
2	1-3686	Spacer	1
3	2-2712	Retainer Jaw	2
4	6-3900	Cylinder Assembly	1
5	6-3883	Cylinder Assembly	1
6	6-3882	Washer, Nylon 1/4" ID 5/8" OD	2
7	6-3929	Cotter Pin, 3/16" x 2" lg, SS	1
8	6-0060	Flat Washer, 1/4" ID	6
9	6-3907	Shoulder Bolt, 1/4" x 5/8" lg. SS	2

16.3 Airline Routing for Locking Turnplates and Rear Slip Plates

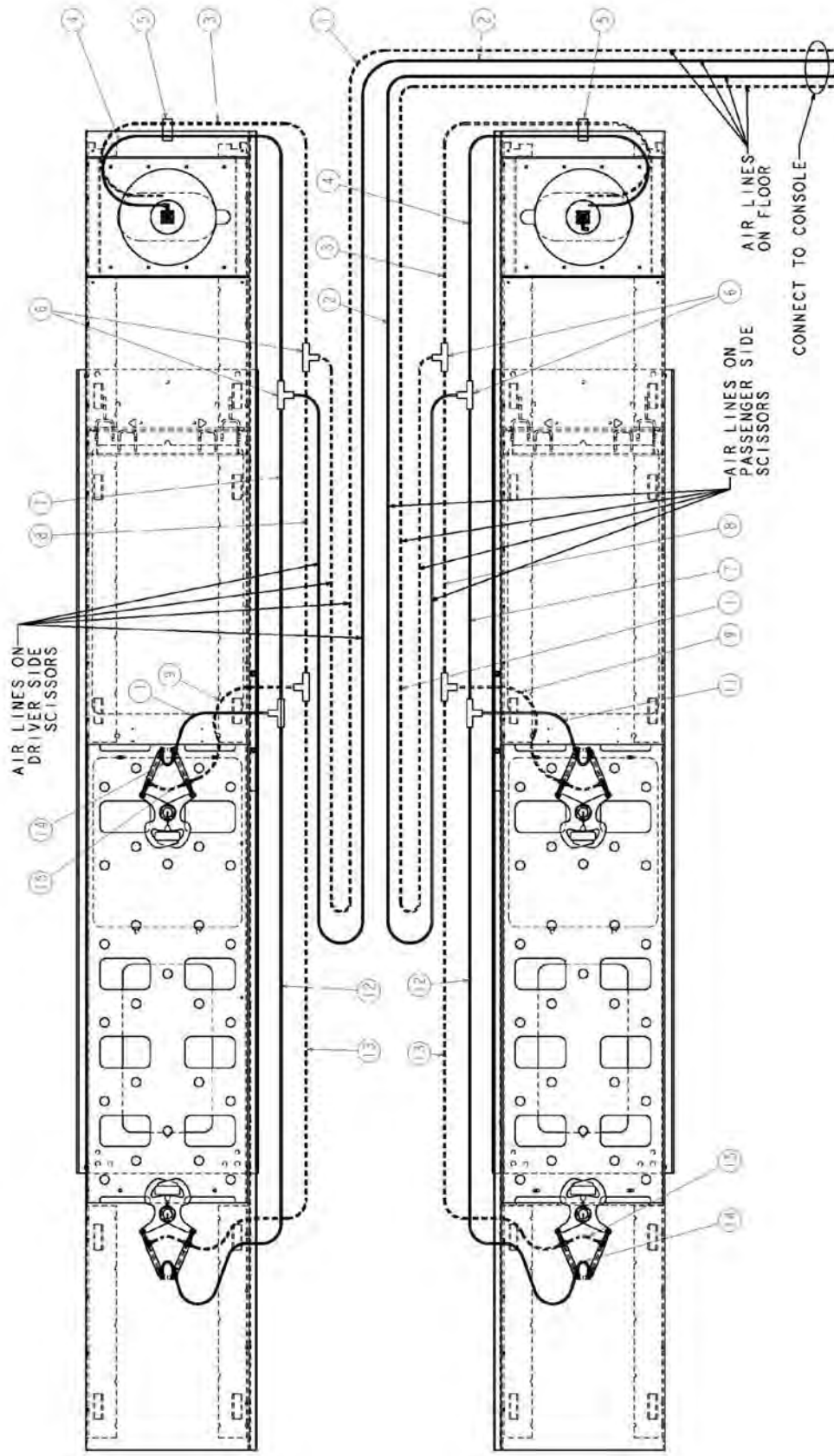

Airline Parts List

Item	Part Number	Description	Location	Qty/Lift
1	1-3733	Air Line, Blue, 1/4", 45'	From Console, on floor, on scissors, up to deck hinge	2
2	1-3732	Air Line, Red, 1/4", 45'	From Console, on floor, on scissors, up to deck hinge	2
3	1-3735	Air Line, Blue, 1/4", 7.8'	On decks, from hinge to front	2
4	1-3734	Air Line, Red, 1/4", 7.8'	On decks, from hinge to front	2
5	6-3950	Tube Clamp	On decks, at front	2
6	6-2971	Fitting, Tee, 1/4"	On decks	8
7	1-3736	Air Line, Red, 1/4", 3.1'	On decks, from hinge to middle	2
8	1-3737	Air Line, Blue, 1/4", 3.1'	On decks, from hinge to middle	2
9	1-3741	Air Line, Blue, 1/4", 1.1'	On decks, feeding middle clamp	2
11	1-3740	Air Line, Red, 1/4", 1.1'	On decks, feeding middle clamp	2
12	1-3738	Air Line, Red, 1/4", 8.25'	On decks, middle to rear	2
13	1-3739	Air Line, Blue, 1/4", 8.25'	On decks, middle to rear	2
14	1-3742	Air Line, Red, 1/4", 5"	Between clamp cylinders, rear and middle	4
15	1-3743	Air Line, Blue, 1/4", 7"	Between clamp cylinders, rear and middle	4

16.4 Rear LED Light Assembly: Exploded View

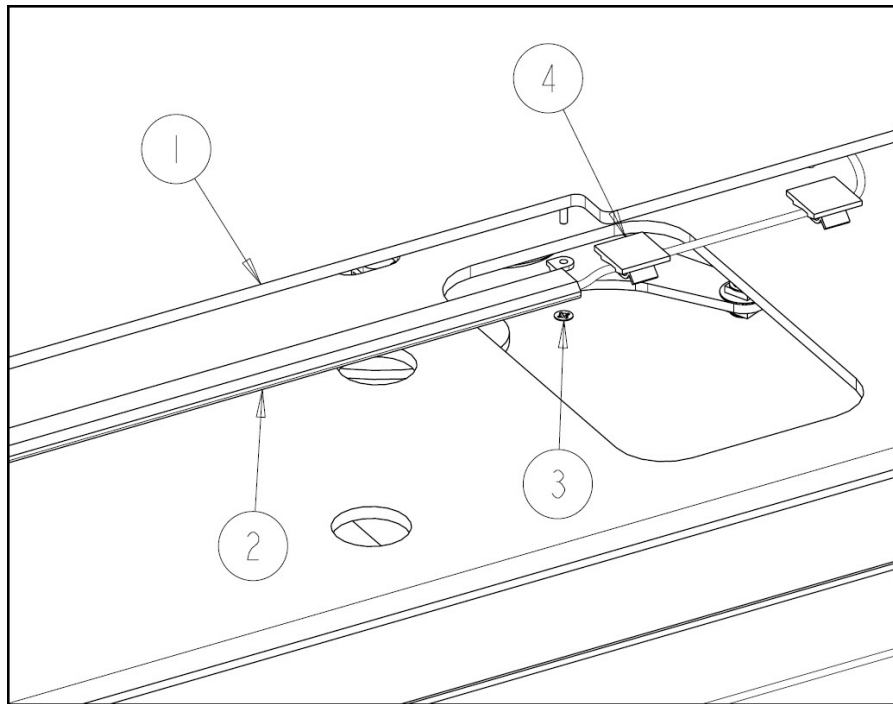

Top of Deck – Rear Slip Plate

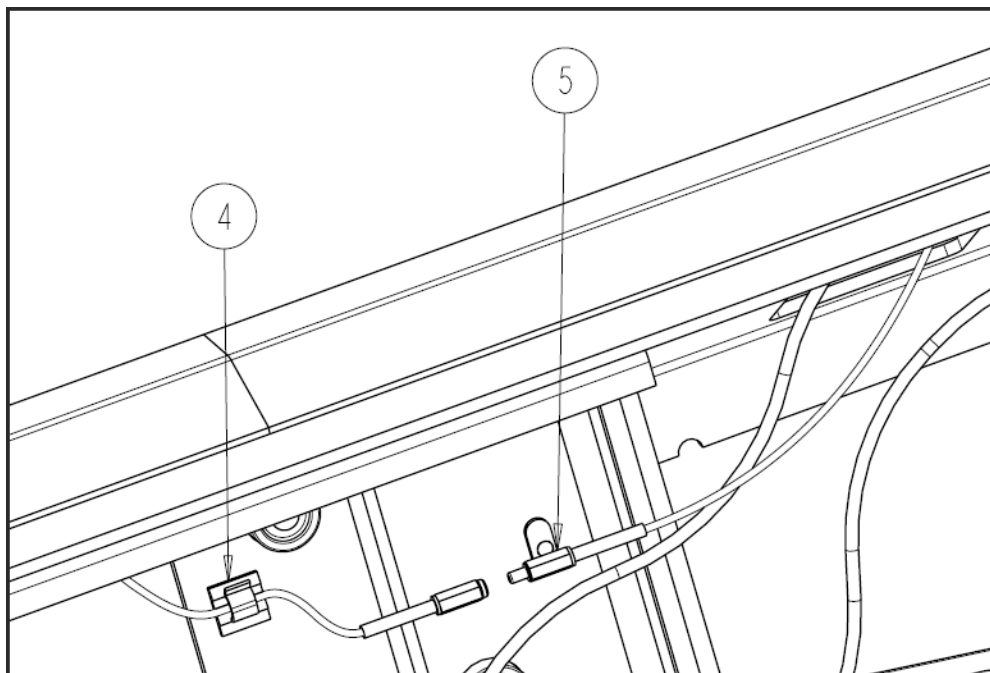

Underside of Deck – Connection of LED Light Bar

REAR LED LIGHT ASSEMBLY: Parts List

Item #	Part #	Description	Qty.
1	2-2721	Rear Slip Plate Weldment, LS	1
	2-2740	Rear Slip Plate Weldment, RS	1
2	6-4020	LED Light Bar w/ mounts & connector (Left side)	1
	6-3922	LED Light Bar w/ mounts & connector (Right side)	1
3	6-3936	Push Retainer	2
4	6-3940	Adhesive Back Clamps	3
5	6-3924	Cable Extension Assembly (F&R)	1

Note:

- Cable Extension Assembly contains Front and Rear cables grouped as an assembly. For single cable replacements, please order part # 6-3949 and specify required color (Red or Blue).

16.5 Air Switch for Light Kit

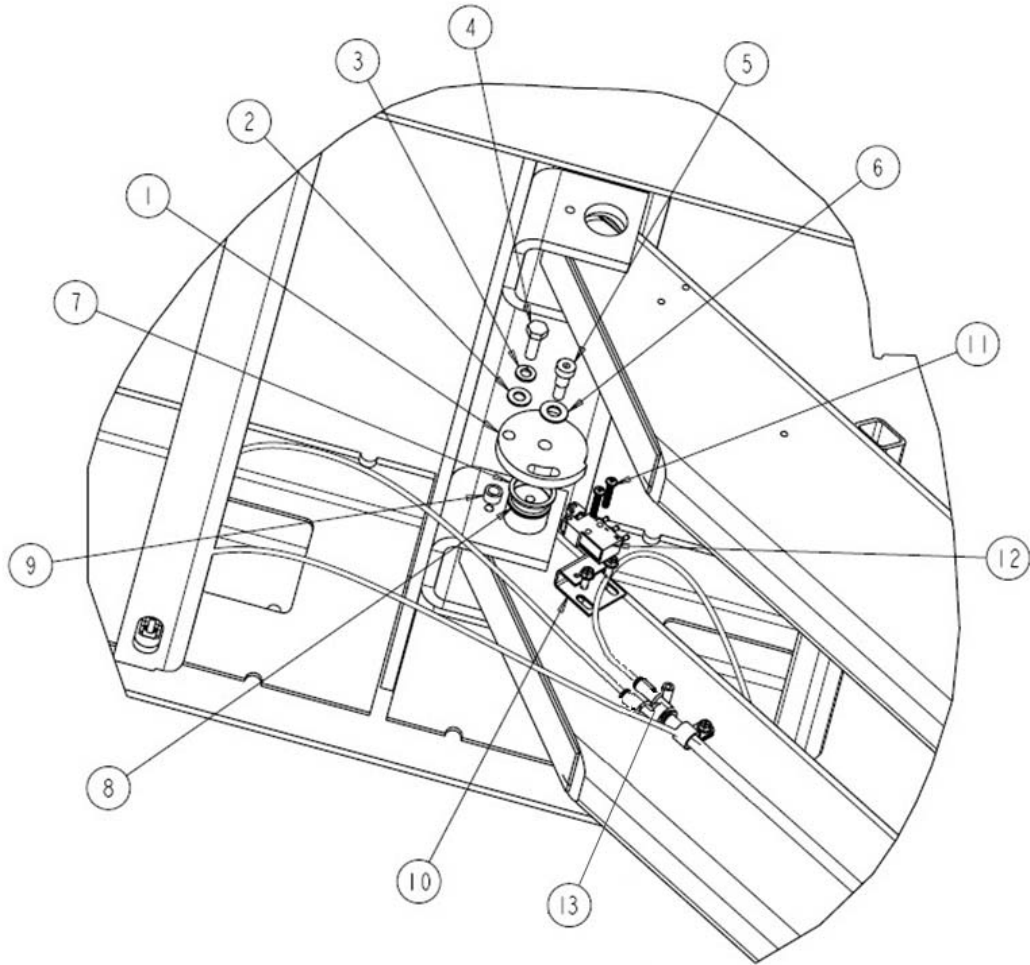

Item #	Part #	Description	Qty.
1	2-2757	Plastic Cam	1
2	6-0295	Flat Washer, 5/16"	1
3	6-0674	Lock Washer, 5/16"	1
4	6-0293	Hex Head bolt, 5/16"-18UNC x 1" Lg.	1
5	6-1792	Shoulder Bolt, 3/8" x 1/2" Lg.	1
6	6-0062	Flat Washer, 3/8"	1
7	6-0340	Circlip	2
8	1-3754	Hinge Pin, Cam	1
9	1-3752	Spacer	1
10	1-3771	Sensor Bracket	1
11	6-3965	Machine screw, #8-32 x 1"lg	2
12	6-3964	Limit Switch w/ Roller Lever	1
13	6-3944	Union, 'Y', 5/32" (4mm) Polytube	1
*	8-0378	4mm Polytube Blue	40 ft
*	8-0377	4mm Polytube Red	40 ft

Note: Light Kit Sensor Assembly is located under Passenger Side Deck.

17.0 CONSOLE ASSEMBLY

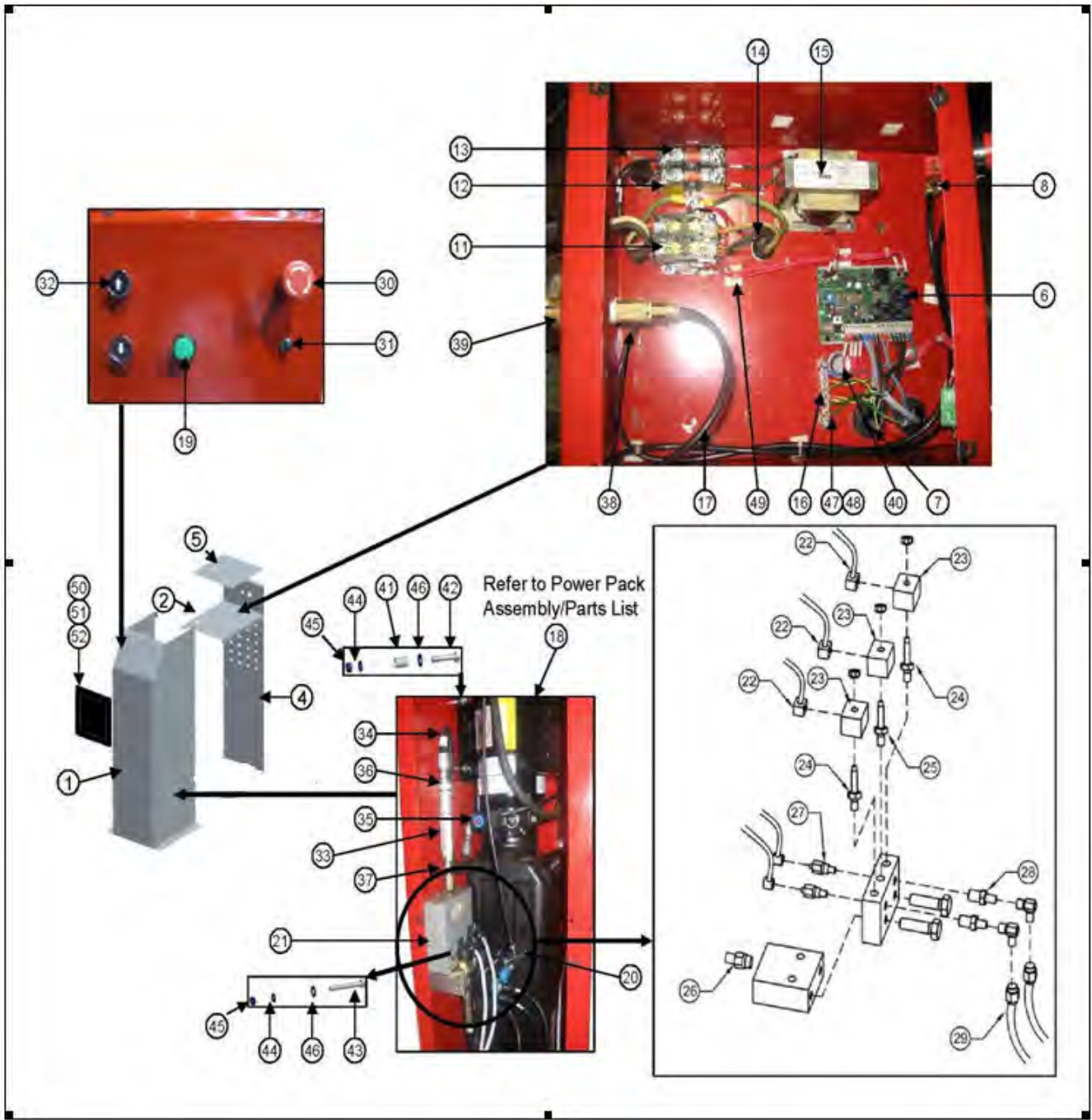

17.1 Console Parts List

Item	Part #	Description	Qty
1	3-0973	Front Side Panel	1
2	3-0974	Back Electrical Plate Cover	1
4	2-2512	Rear Cover	1
5	2-2513	Top Cover	1
6	6-2125	Printed Circuit Board	1
7	6-3409	Multihole, 3 holes x 7 mm 189.637	2
8	6-0709	Elbow, 90 deg.	1
11	6-3406	Contactora Tayco P/N 3100-20	1
12	6-3266	Fuse Holder 2-Pole Open Style	1
13	6-3597	Fuse, 1A 250V	2
14	6-3410	Bushing Heyco P/N 184.175	1
15	6-2126	Transformer	1
16	6-3415	Grounding Bar	1
17	8-0141	1/4" Polytube, 2 ft.	1
18	6-3720	PowerPack Assy. 230V/1PH/60Hz	1
19	6-3580	Green LED pilot lamp	1
20	6-2971	1/4" Polytube Tee Pushlock	1
21	6-3665	Flow Divider c/w Solenoids	1
22	1-3625	Din Connector High Body Small Conduit	4
23	6-2128	Coil S8 24VDC	4
24	6-2129	Cartridge Valve N/C with manual override	3
25	6-1364	Cartridge Valve Equalize VEI DT	1
26	6-2553	Filter fitting 1/2 BSP #6 JIC c/w Bonded Seal	1
27	6-3684	Pressure SW 80 psi	2
28	6-2127	Filter fitting 3/8 BSP #6 JIC c/w Bonded Seal	2
29	2-2177	Hydraulic Hose	2
30	6-2922	Emergency Pushbutton Contact	1
31	6-1055	Air Release Button	1
32	6-1247	Pushbutton	2
33	6-0090	Flow Control	1
34	2-2592	Hydraulic Hose Ass'y	1
35	6-0804	Elbow, 90 deg.	1
36	6-0011	Adapter, 3/8" M NPT x 3/8" M JIC	1
37	6-0797	Adapter 3/8" NPT M x 3/8"	1
38	6-0710	Adapter 3/8" x 3/8" Polytube	1
39	6-0713	Terminal Bolt, 3/4" (Short)	1
40	6-2314	Electrical Knockout Plug	1
41	1-3282	Power Pack mounting spacer	4
42	6-3421	Screw BHCS 5/16"-18 x 1 1/2"	4
43	6-3422	Screw BHCS 5/16"-18 x 2 1/2"	2
44	6-0674	Washer, Lock 5/16" ID	6
45	6-0294	Nut, 5-16" - 18 UNC Hex	6
46	6-0295	Washer, Flat 5/16" SAE	6
47	6-3423	Screw Pan Sq. SEFL 8 x 1/2" Zinc	15
48	6-3424	Screw 10 x 3/4" Zinc	3
49	6-3305	Hold Down Adhesive Mount Base	5
50	6-0988	Decal Set, ALI/WL 200	1
51	6-2481	Decal, Elec 208 - 230, 60 Hz 1PH 20A	1
52	6-1766	Decal, Capacity 10000lb/4550kg	1

17.2 Console Pneumatic / Filtering System

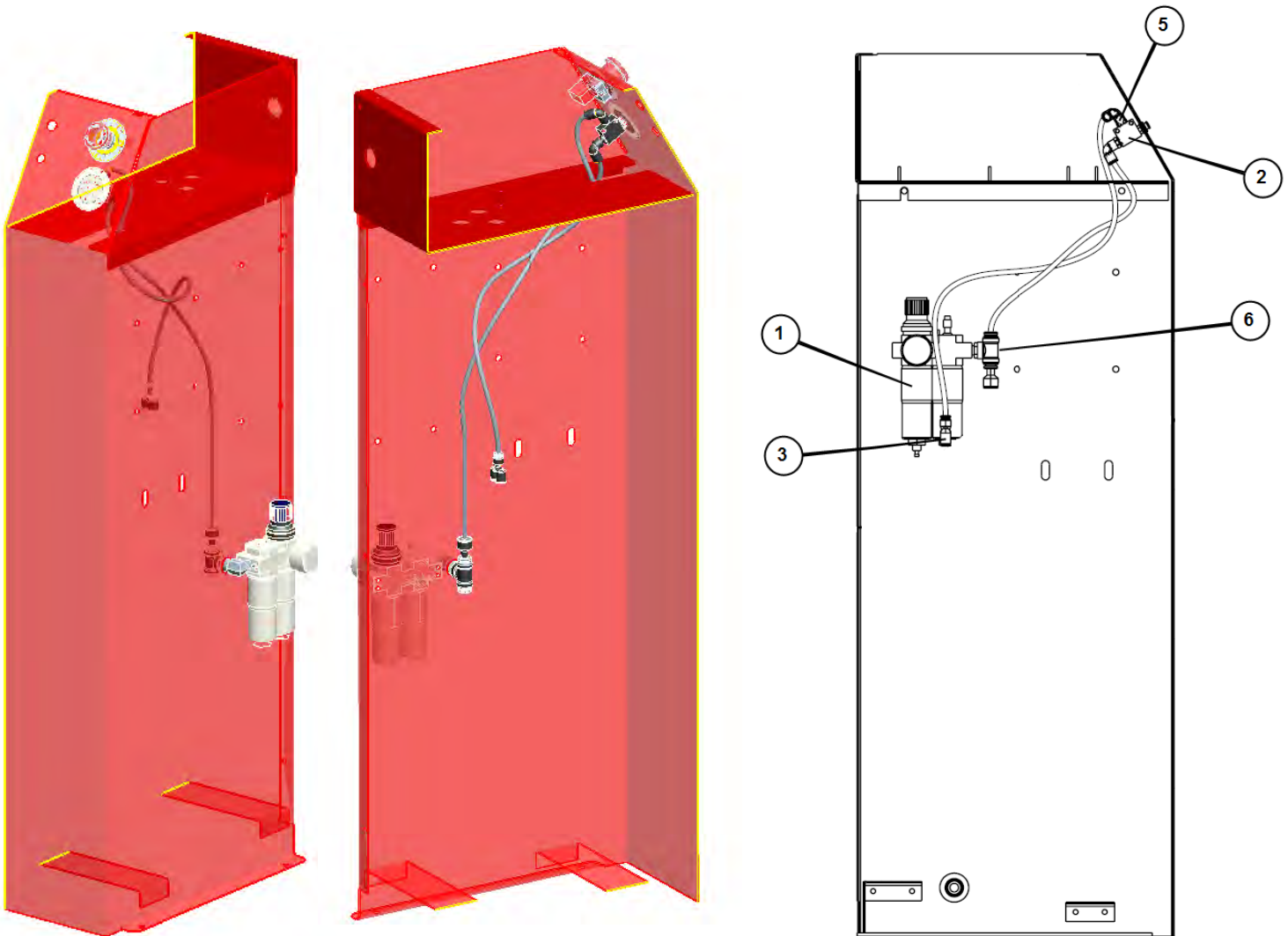

ITEM	PART #	DESCRIPTION	QTY
1	0-1693	Water Separator / Regulator / Lubricator Kit	1
2	6-1055	Control Valve	1
3	6-3729	Union 'Y', 1/4" Poly	1
4	6-0015	90° Elbow 1/4 NPT	1
5	6-0709	Swl Elbow, 1/4" POLY x 1/8" NPT M	2
6	6-3730	Swl Tee Adapter, 3/8 Poly X 3/8 Poly X 1/4 NPT	1

17.3 Console: Pneumatic & Filtering System - Locking & Light System (Optional)

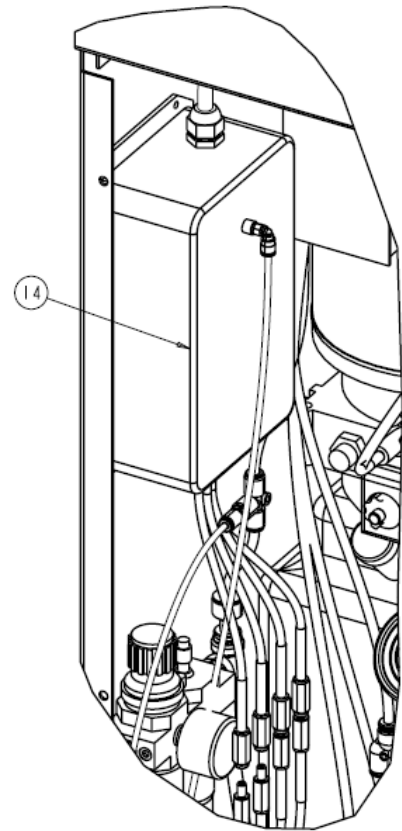
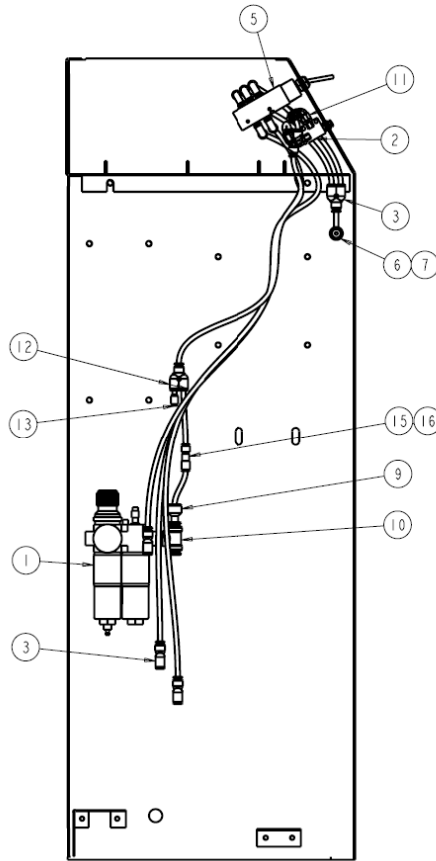

Item #	Part #	Description	Qty.
1	6-3680	Water Separator/Regulator/Lubricator Ass'y	1
2	6-1055	Control Valve (Safety Release)	1
3	6-3729	Union 'Y', 1/4" Poly	5
5	6-3919	Valve Assembly (Locking Plates)	1
6	6-0708	Adapter, 1/8" NPT - 1/4" Poly	1
7	6-3977	Breather - Female 1/8" NPT	1
9	6-3731	Reducer, 3/8" Stem x 1/4" Poly	1
10	6-3730	Swivel Tee Adapter, 1/4"NPT x 3/8" Poly	1
11	6-0709	Swivel Elbow, 1/8" NPT M x 1/4" Poly	2
12	6-3729	Union 'Y', 1/4" Poly	1
13	6-3928	Reducer, 1/4" Stem x 5/32" (4mm) Poly	1
14	6-3923	LED Driver Box Assembly	1
15	6-3952	Check Valve, 1/4" Poly	1
16	6-0015	90° Elbow 1/4 NPT	1

17.4 Console Labeling

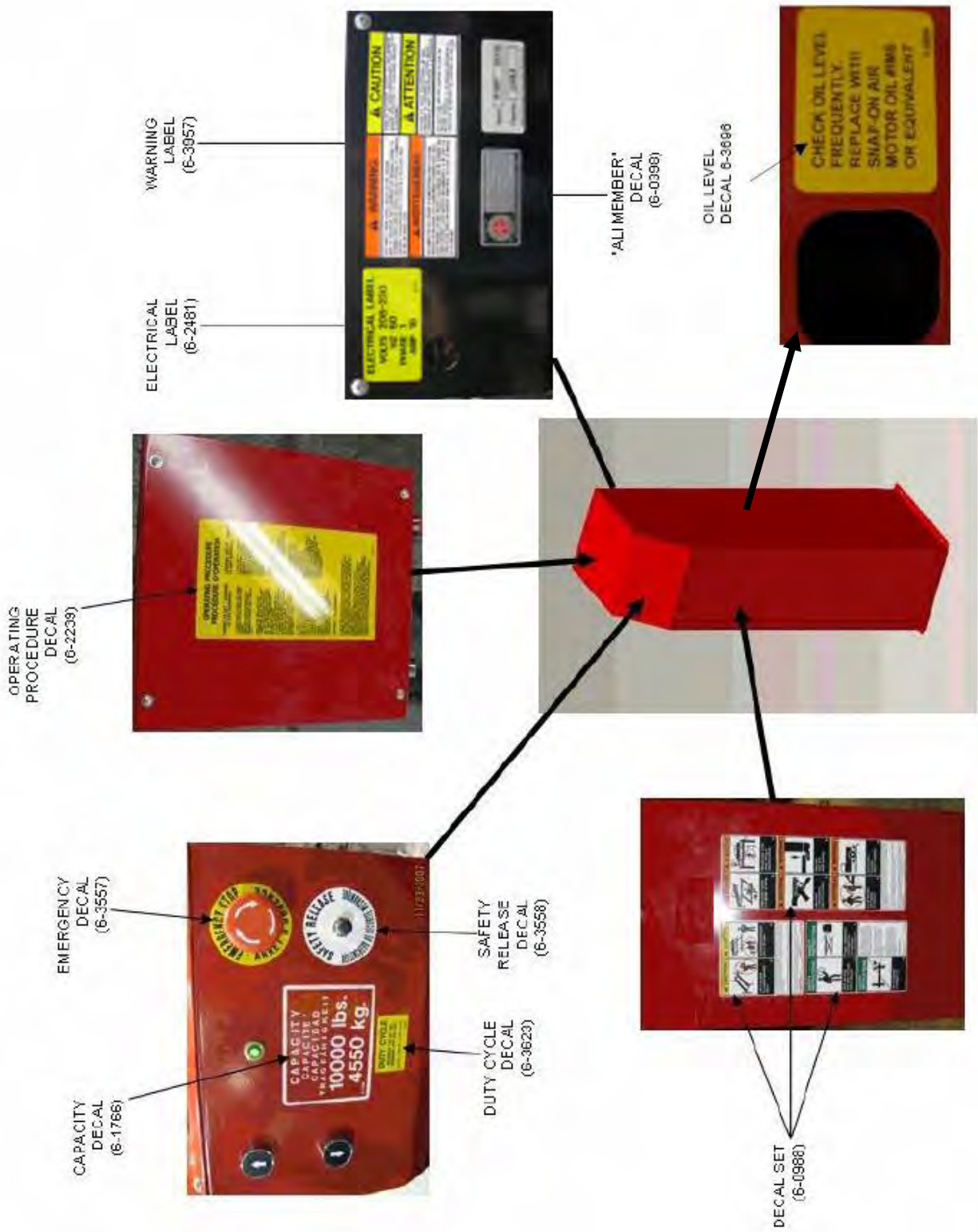

18.0 POWER PACK ASSEMBLY

NOTE: THERE ARE 2 TYPES OF POWERPACKS USED WITH THIS LIFT.

TYPE 1:

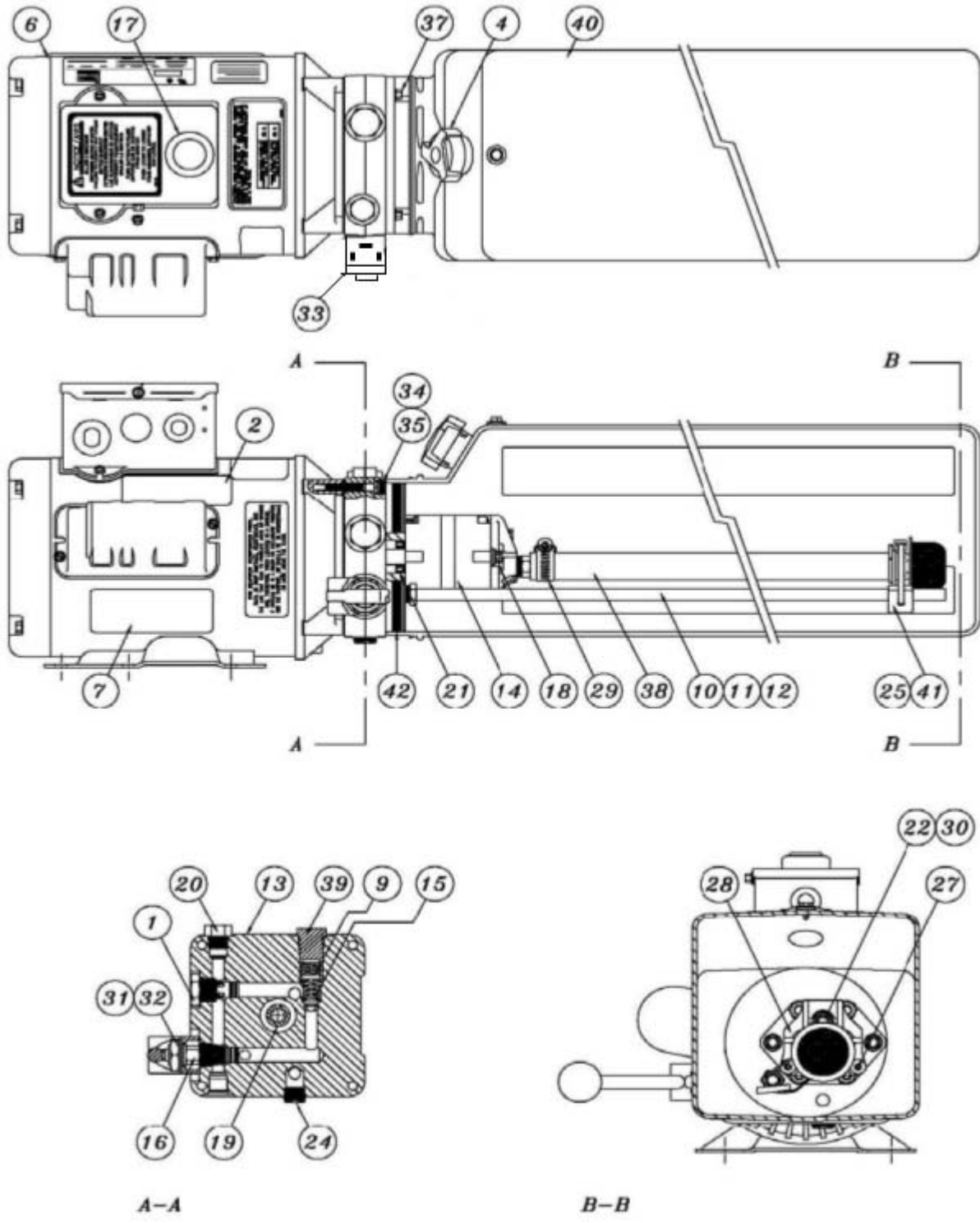

#6-3484 (AB-6842) 230V/1PH/60Hz

Item	Part #	Description	Qty
1	6-1087	VALVE CARTRIDGE CHECK	1
2	6-2136	LABEL INSTALLATION AUTOHOIST	1
4	6-1376	BREATHER CAP & BLADDER	1
6	6-2139	MOTOR AC 208-230V. 2HP/1PH/60HZ, BLK	1
	6-1079	MOTOR AC 208-230V. 2HP/3PH/60HZ, BLK	1
7	6-2149	LABEL WARNING AUTOHOIST	1
9	6-2151	SPRING 0.480" X 0.063" X 0.42" COMP	1
10	6-2152	RETURN HOSE 3/8" OD X 21.5"	1
11	6-2153	COMPRESSION TUBE NUT	1
12	6-2154	COMPRESSION TUBE SLEEVE	1
13	6-2155	ENDHEAD UNIVERSAL AUTOHOIST	1
14	6-1958	PUMP ASS'Y 2.5 CC/REV. SHORT SLINE	1
15	6-1319	RELIEF ASSEMBLY FIXED 190 BAR	1
16	6-0880	VALVE CARTRIDGE RELEASE MANUAL	1
17	6-2156	WIRING ASSEMBLY AC 1PH FENNER	1
18	6-1090	BOLT 5/16"-24 X 3.00" TORX G8	2
19	6-0774	COUPLING SAE 9T-20/40 1.260"	1
20	6-2157	PLUMBING PLUG 9/16" SAE	1
21	6-2158	SEAL SHAFT 0.500" X 1.00" X 0.25"	1
22	6-2159	WASHER 0.338" X 0.625" X 0.060" STEEL	1
24	6-2161	PLUMBING PLUG 3/8" NPT	1
25	6-2162	PLUMBING MAGNET	1
27	6-2164	SCREW TAPTITE M6 X 1.0 12MM TORX	2
28	6-2165	COVER ASS'Y SUCTION	1
29	6-2166	PLUMBING CLAMP HOSE ADJ. INLET	1
30	6-1392	BOLT 5/16" - 18 X 1.00" SHCS	1
31	6-2167	NUT 3/4" -16 X 1" HEX X 0.25" STEEL	1
32	6-2168	WASHER 3/4" INT. TOOTH LOCK	1
33	6-2129	CARTRIDGE	1
	6-2128	COIL 24V	1
34	6-2169	BOLT M6 X 1.0 35MM SOC HD	4
35	6-2170	WASHER 1/4" LOCK HI-COLLAR	4
37	6-1091	BOLT #12-24 X 0.50" HEX HD WASHER	4
38	6-0786	PLUMBING ASS'Y INLET 17.24 (3)	1
39	6-1089	RELIEF VALVE CAP ASSEMBLY	1
40	6-1399	TANK PLASTIC 6.7 OS 22.50" BLK	1
41	6-1846	CABLE TIE 8" LONG WHITE	1
42	6-0875	O-RING 2-348 BUNA	1

TYPE 2:

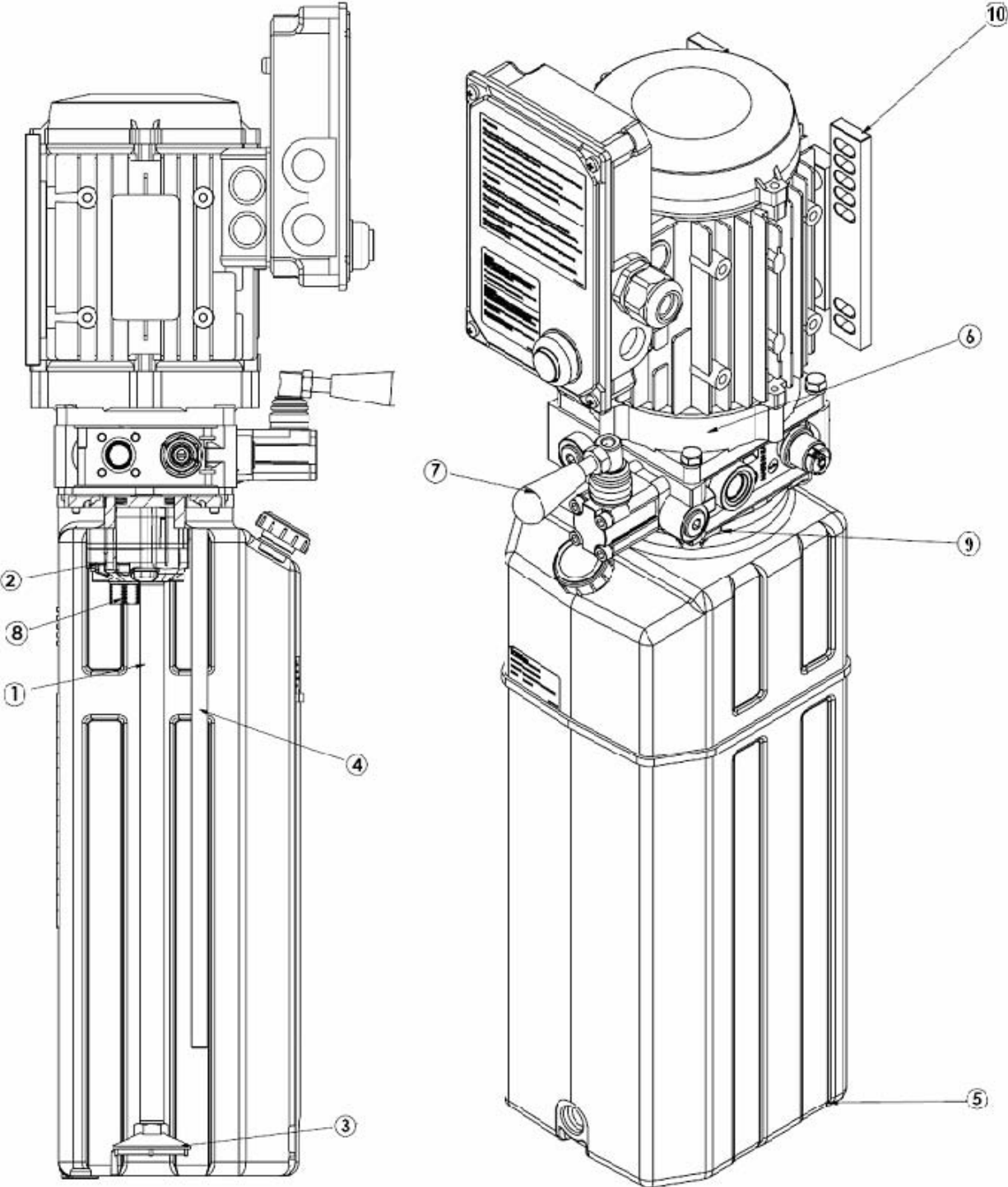

6-2055 (46.832.17.0004) 230 V / 1 PH / 60 HZ

Item	Part #	Description	Qty
1	6-3442	Pump 6.7G, 16 Gear	1
2	6-3443	Suction Pipe 3/8"	1
3	6-3444	Suction Filter 3/8" Female 15 L/min	1
4	6-3445	Return Pipe	1
5	6-3446	Plastic tank 12L	1
6	6-3447	Motor Shaft Coupling Pump	1
7	6-3448	Manual Valve	1
8	6-3452	Start Up Valve	1
9	6-3449	Tank Bracket With Screws	1
10	6-3450	Motor Brackets	1

19.0 AVAILABLE ACCESSORIES

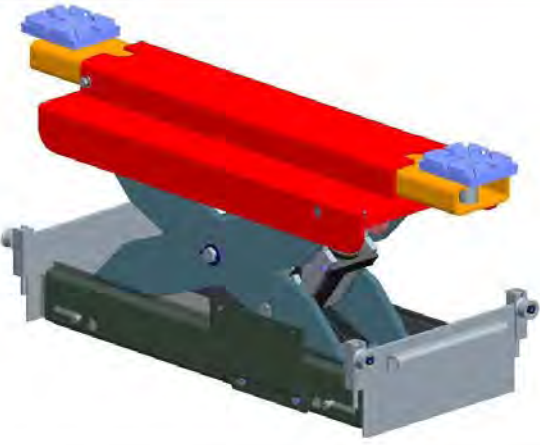
	<p>5K Jackbeam</p> <ul style="list-style-type: none"> • Air/Hydraulic Pump • 2 Safety locking Positions • 3" & 6" Adapter • Adjustable width
<p>5000 lb max capacity each</p>	

Contact supplier for availability and part numbers.

Max capacity is for 10,000 Lb Lifts.