

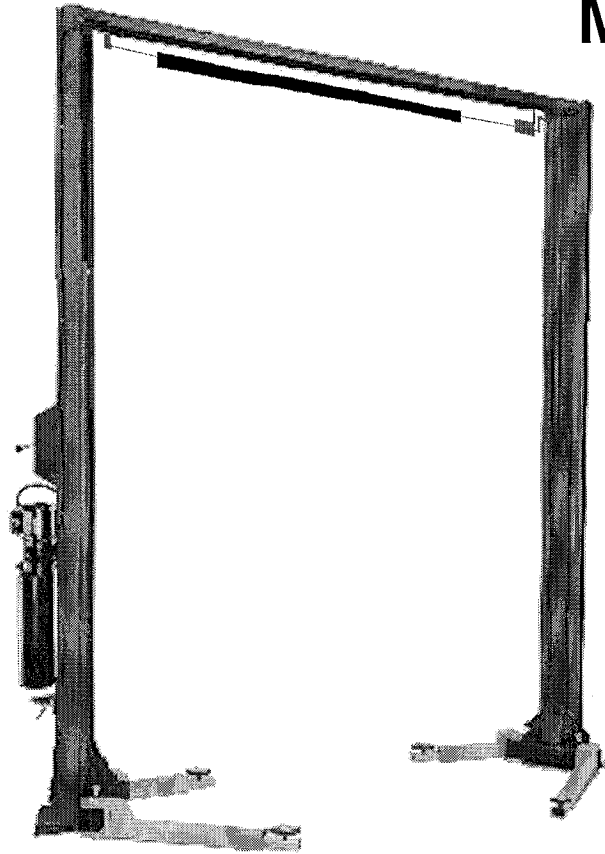

WHEELTRONIC LTD.

INSTALLATION and OPERATION MANUAL



CE



VECTOR
(MODEL 11168VS)
11000 LB.

**READ and SAVE THIS
INSTRUCTION MANUAL**

OCT. 1999 6-1617

WHEELTRONIC LTD.

**EXPLODED
VIEWS AND
PARTS LISTS**

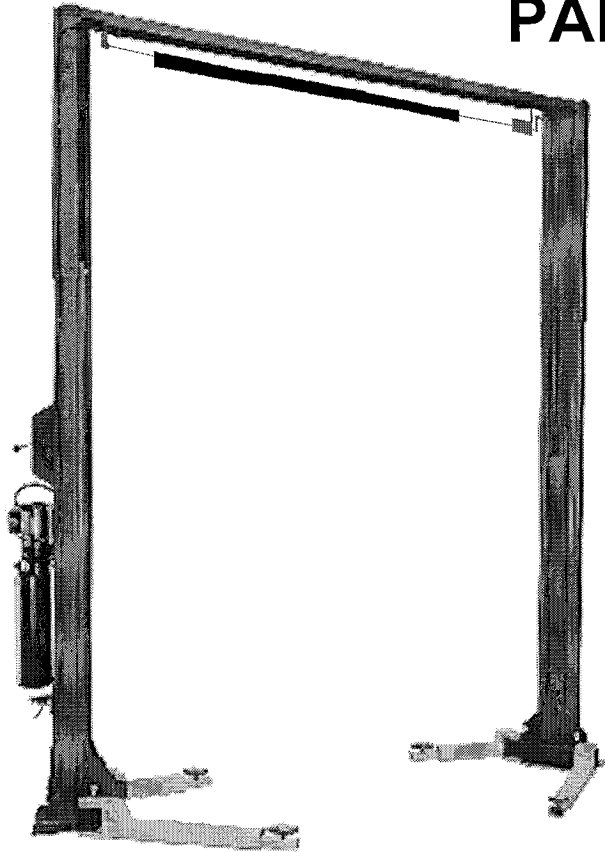

CE



**VECTOR
(MODEL 11168VS)
11000 LB.**

**READ and SAVE THIS
INSTRUCTION MANUAL**

OCT. 1999 6-1617

TABLE OF CONTENTS

PAGE

1. SAFETY AND OPERATING INSTRUCTIONS	1
2. SPECIFICATIONS	2
3. CONTENTS	3
4. INSTALLATION REQUIREMENTS AND TOOLS	4
5. INSTALLATION INSTRUCTIONS	5
5.1 BAY LAYOUT	6
5.2 SAFETY SHUT-OFF BAR INSTALLATION	7
5.3 SAFETY SHUT-OFF BAR ADJUSTMENT	8
5.4 TOWER POSITIONING AND SETUP	9
5.5 ARM INSTALLATION	10
5.6 POWER PACK INSTALLATION	11
5.7 HYDRAULIC SYSTEM INSTALLATION.....	13
5.8 SAFETY RELEASE CABLE ROUTING AND ADJUSTMENT.....	15
5.9 HYDRAULIC SYSTEM BLEEDING AND LEVELING PROCEDURE	17
5.10 HYDRAULIC ADJUSTMENT PROCEDURE.....	18
5.11 TOWER POSITIONING AND ANCHORING	19
5.12 SHIMMING OF THE REMAINING TOWER.....	20
5.13 ARM LOCKS ADJUSTMENT	21
6. PERIODIC MAINTENANCE.....	22
7. SAFETY AWARENESS - AUTOMOTIVE LIFT INSTITUTE (ALI).....	23
8. PARTS MANUAL	
8.1 LIFT ASSEMBLY DIAGRAM.....	25
8.2 LIFT PARTS LIST.....	26
8.3 HYDRAULIC SYSTEM DIAGRAM.....	28
8.4 HYDRAULIC PART LIST.....	29
8.5 POWER PACK DIAGRAM.....	30
8.6 POWER PACK PART LIST.....	31

1. SAFETY AND OPERATING INSTRUCTIONS

1. Read all instructions.
2. Inspect lift daily. Do not operate if it malfunctions or problems have been encountered.
3. Never attempt to overload the lift. The manufacturer's rated capacity is shown on the identification label on the power side column.
Do not override the operating controls or the warranty will be void.
4. Only trained and authorized personnel should operate the lift. Do not allow customers or bystanders to operate the lift or be in the lift area.
5. Position the lift support pads to contact the vehicle manufacturer's recommended lifting points. Raise the lift until the pads contact the vehicle. Check pads for secure contact with the vehicle, then raise the lift to the desired working height.
6. Some pickup trucks may require an optional truck adapter to clear running boards or other accessories.
NOTE: Always use all 4 arms to raise and support vehicle.
7. **Caution! Never work under the lift unless the mechanical safety locks are engaged.**
8. Note that the removal or installation of some vehicle parts may cause a critical load shift in the center of gravity and may cause the vehicle to become unstable. Refer to the vehicle manufacturer's service manual for recommended procedures.
9. Always keep the lift area free of obstruction and debris. Grease and oil spills should always be cleaned up immediately.
10. Never raise vehicle with passengers inside.
11. Before lowering check area for any obstructions.
12. Before driving vehicle between the towers, position the arms to the drive-through position to ensure unobstructed clearance. Do not hit or run over arms as this could damage the lift and/or vehicle.
13. Before removing the vehicle from the lift area, position the arms to the drive-through position to prevent damage to the lift and /or vehicle.
14. Care must be taken as burns can occur from touching hot parts.
15. Do not operate equipment with a damaged cord or if the equipment has been dropped or damaged – until a qualified serviceman has examined it.
16. Do not let cord hang over table, bench or counter or come in contact with hot manifolds or moving fan blades.
17. If an extension cord is necessary, a cord with a current rating of two or more than that of the equipment should be used. Cords rated for less current than the equipment may overheat. Care should be taken to arrange the cord so that it will not be tripped over or pulled.
18. Always unplug the equipment from electrical outlet when not in use. Never use the cord to pull the plug from the outlet. Grasp plug and pull to disconnect.

2. SPECIFICATIONS

Capacity:
 Overall Width:
 Width Between Columns:
 Drive-Thru Width:
 Overall Height:
 Under Bar Clearance:
 Height to Lowered Lift Pads:
 Height to Raised Low Lift Pad:
 Height to Raised High Lift Pad:
 Retracted Arm Length:
 Extended Arm Length:
 Maximum Lifting Height:
 Lift Time:
 Power Requirements (Standard):

11000 lbs.	5000 kg
140 3/4"	3575mm
120"	3048mm
106 1/2"	2705mm
168"	4267mm
164 1/4"	4172mm
5"	127mm
6 3/4"	171mm
9 3/4"	248mm
32 1/4"	819mm
51"	1295mm
78 1/4"	1988mm
45 seconds	
230 Volts AC, 1 Ph., 60Hz.	

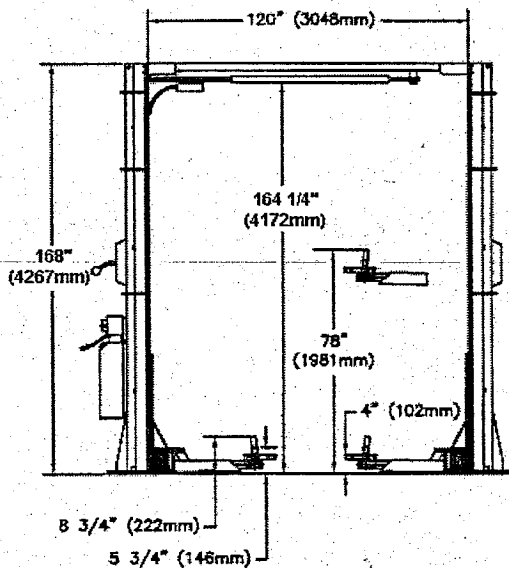

Figure 1

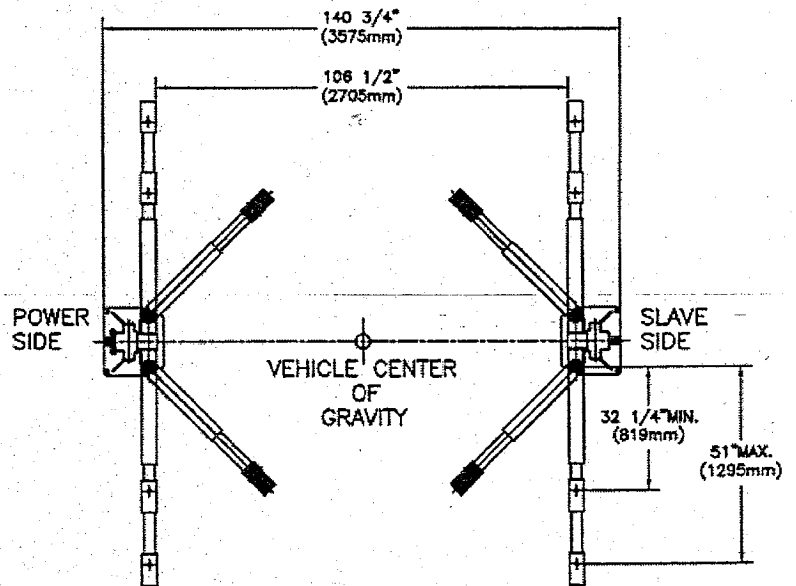

Figure 2

3. CONTENTS

The complete lift is contained in two (2) packages:

1. The **main structural components** are packed in a steel frame.
2. The remaining parts are packed in an **accessory box**.

Main Structural Components includes:

- 1pc. Power side tower and carriage assembly
- 1pc. Slave side tower and carriage assembly
- 1pc. Crossmember
- 1pc. Hydraulic line for crossmember

Accessory box contents:

- 4pcs. Locking arm ass'y w/arm pins
- 2pcs. Safety Covers w/Decals
- 1pc. Power Pack
- 1pc. Safety release cable assembly
- 1pc. Valve Block (C/W Fittings)
- 1pc. Safety shut-off microswitch assembly
- 1pc. Hardware package w/Packing List
- 1pc. Owner's manual
- 1pc. ALI manual "Lifting It Right"
- 1pc. Automotive Lift Safety Tips
- 1pc. Automotive Lift, Operation, Inspection and Maintenance manual
- 1pc. "ALI" Quick Reference Guide

4. INSTALLATION REQUIREMENTS AND TOOLS

IMPORTANT: It is the user's responsibility to provide a satisfactory installation area for the lift. Lifts should only be installed on level concrete floors with a minimum thickness of five (5) inches or 130 mm. Concrete must have a minimum strength of 4000 psi or 30 MPa and should be aged thirty (30) days prior to installation. Please consult the architect, contractor or engineer if doubt exists as to the strength and feasibility of the floor to enable proper lift installation and operation.

It is the user's responsibility to provide all wiring for electrical hook-up prior to installation and to insure that the electrical installation conforms to local building codes. Where required, it is the user's responsibility to provide an electrical isolation switch located in close proximity to the lift that will enable emergency stop capability and isolate electrical power from the lift for any servicing requirements.

Tools Required:

1. 16ft. Measuring Tape
2. Chalk Line
3. Rotary Hammer Drill
4. diameter Masonry Drill Bit
5. Hammer
6. SAE Wrenches and Ratchet Set
7. 2ft. Level
8. 4ft. Level
9. Crow Bar
10. One 12ft. Step Ladder
11. Side Cutters
12. Screwdrivers
13. 15ft. Bleeder Hose (Clear) w/ 3/8" JIC Swivel F fitting on one end
14. 4"x4" Wooden Blocks (for unpackaging)

5. INSTALLATION INSTRUCTIONS

When the lift arrives on site, please read the owner's manual and check for any freight damages. Also, check the contents to make sure no parts are missing before starting installation. Gather all the tools listed and make sure the installation instructions are fully understood before commencing installation.

UNPACKING PROCEDURE

1. **Important!** Place the main structural components on wooden blocks so that the steel frames can be removed.
2. Remove plastic wrapping.
3. Remove crossmember, and hydraulic line.
4. Remove steel frames.
5. Lay towers on floor with the carriage side up.
6. Check the installation area for obstructions. (Lights, Heating Ducts, Ceiling, Floor Drains...etc.)
7. Prepare the bay by selecting the location of the lift relative to the walls. Clear area of all packaging materials to avoid trip hazards. Draw a chalk line on the floor to represent the center line of the bay and a second chalk line crossing at 90° for locating the lift towers. Refer to **Figure 3**.

5.1 BAY LAYOUT

Figure 3

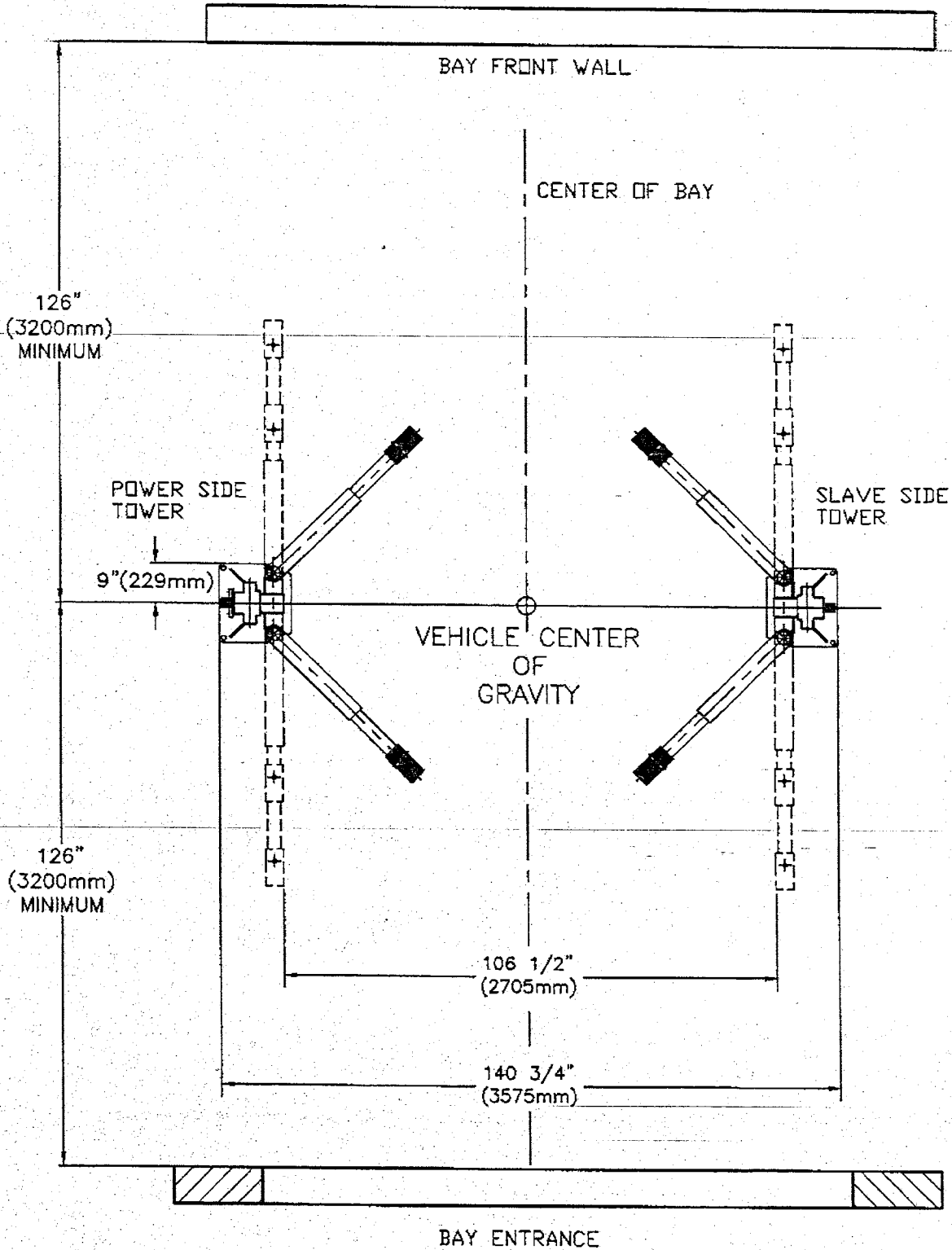

5.2 SAFETY SHUT-OFF BAR INSTALLATION

Note: The safety shut off will disconnect the power to the power pack when an obstruction touches the padded bar or the carriages reach their maximum extension. The safety shut off switch is factory pre-wired. Refer to Figure 4 and Figure 5.

Note: This procedure can be done on the floor.

1. Attach the actuator mounting bracket (1-1378) to the crossmember using hex head bolt 1/4" NC x 3/4" lg. bolt (6-0178), lockwasher 1/4" dia. (6-0056), and hex nut 1/4" NC (6-0032).
2. Attach the actuator bar assembly to the actuator mounting bracket assembly using hex head bolt 1/4" NC x 1 1/4" lg. (6-0027), lockwasher (6-0056), and hex nut 1/4" NC (6-0032).
3. Slide the safety shut-off microswitch assembly over open end of actuator bar and bolt the assembly to the crossmember using hex head bolt 1/4" NC x 3/4" lg. (6-0178), lockwasher (6-0056), and hex nut 1/4" NC (6-0032).
4. Bolt actuator extension (1-1379) onto open end of actuator bar using (2x) hex head bolt 1/4" NC x 1 1/4" lg. (6-0027), lockwasher (6-0056), and hex nut 1/4" NC (6-0032).

Figure 4

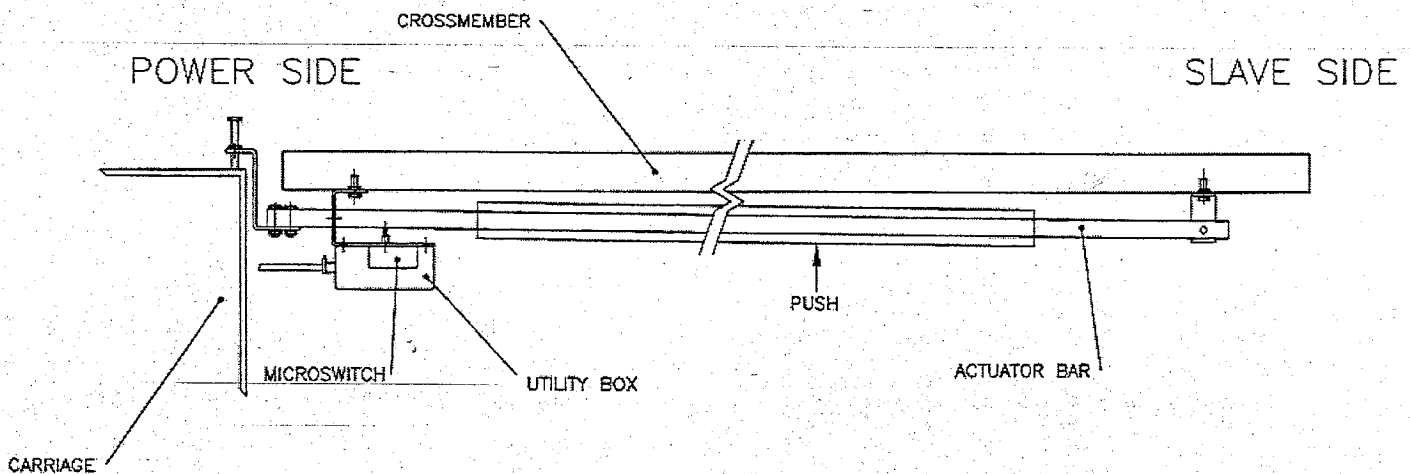

5.3 SAFETY SHUT-OFF BAR ADJUSTMENT

Note: This procedure must be done last.

1. When the lift is fully installed, leveled, and operational, extend the carriages to their full upper limit.
2. Lower the carriages about 1/4" to 1/2".
3. Adjust the stopper bolt by threading the upper nut towards the head, and the lower nut towards the bottom.
4. The bottom of the bolt should be touching the top of the carriage.
5. Tighten both stopper nuts onto the actuator bar extension.

Figure 5

POWER SIDE

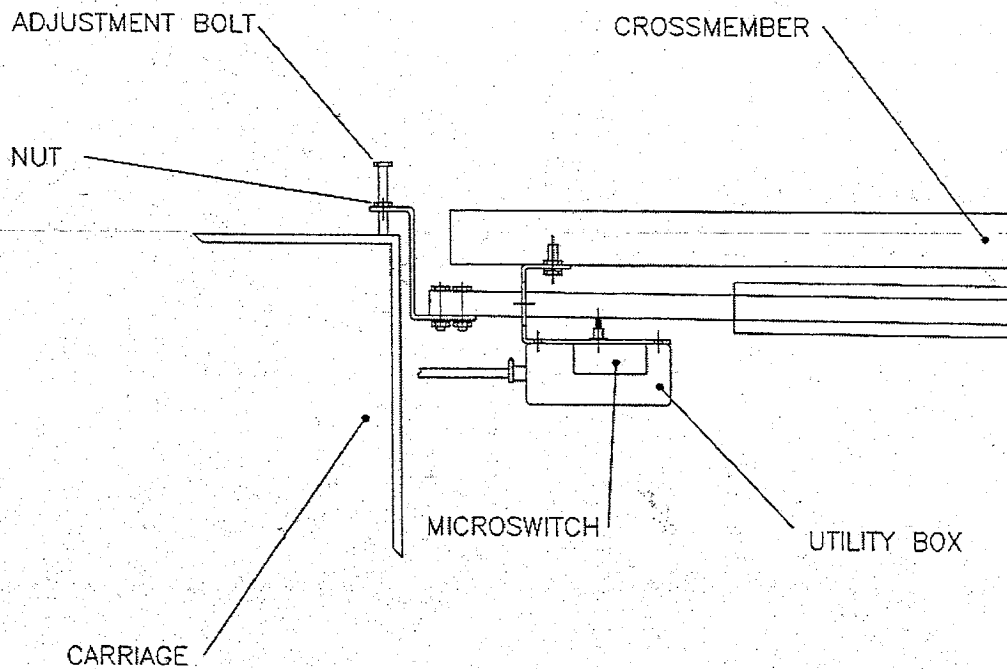

5.4 TOWER POSITIONING AND SETUP

1. Locate the power side and slave side tower to the relative position as shown on **Figure 3**. Double check all dimensions.
2. Using a step ladder, install the crossmember. Raise and place the crossmember mounting hooks over the top of the tower. Install and **tighten** the crossmember using eight (8) 1/2"-13UNC x 1 1/4"LG. hex head bolts, flat washers, lockwashers and hex nuts.
3. Check the towers to make sure they are located, and positioned in the correct location. Refer to **Figure 3**.

5.5 ARM INSTALLATION

1. Remove (4) 5/16"-18UNC x 3/4" LG. hex head bolts that are locking the arm pins to the arm. Install arms to carriages. Install so that the shorter arms (with the 30° bend) are on the front, and the long arms on the rear. Refer to **Figure 6**.
2. Grease and insert arm pins. Align notch on arm pins to the tapped hole on the arm. Using the 5/16" hex head bolts removed in previous step, reinstall and tighten securely.

NOTE: Arm locking device to be installed in Section 5.13.

ARM INSTALLATION

Figure 6

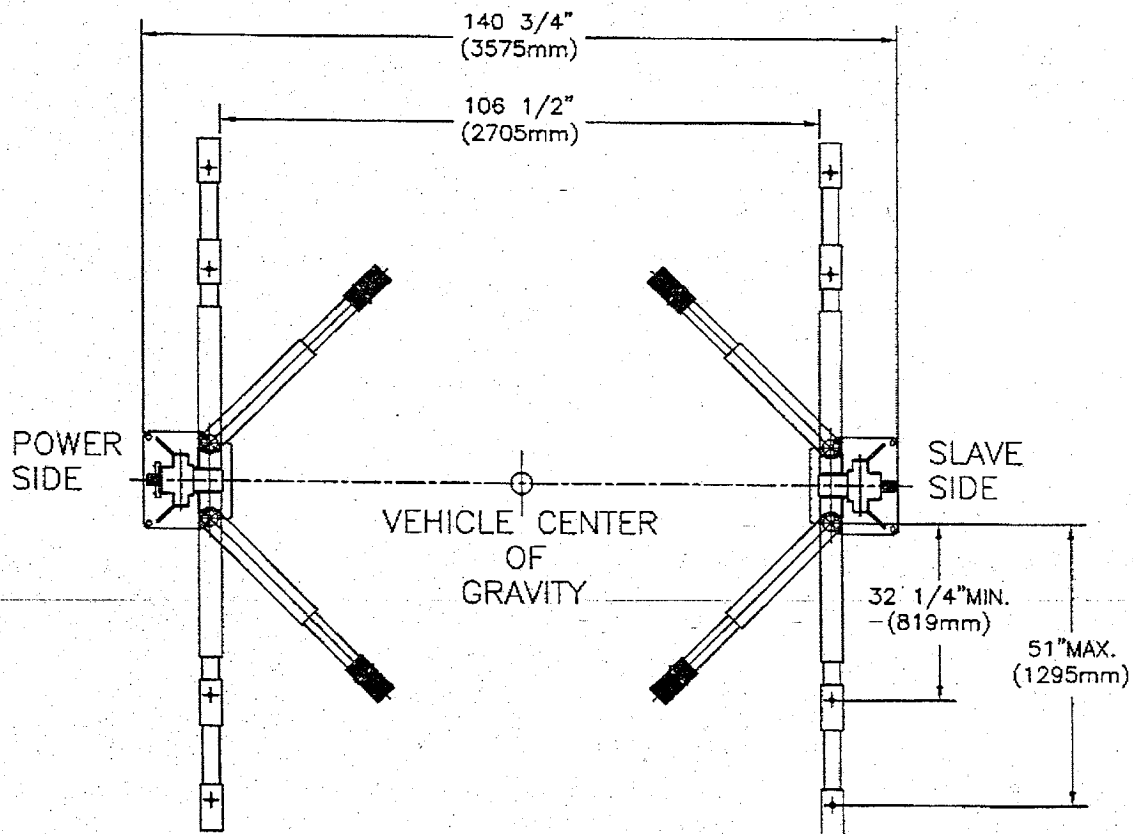

5.6 POWER PACK INSTALLATION

1. Remove the red plastic cap located at the rear of the power pack, and install the 90° fitting (page 28, item 18) located in the hardware kit.
2. Bolt power pack to the mounting bracket on the power side tower using four (4) 5/16"-18UNC x 1" LG. hex head bolts, lock washers, flat washers and nuts. Do not tighten.
3. A **certified electrician** must connect the 230 Volt/Single phase power to the motor. The electrical diagram is provided, refer to **Figure 8**.

POWER PACK DETAILS

Figure 7

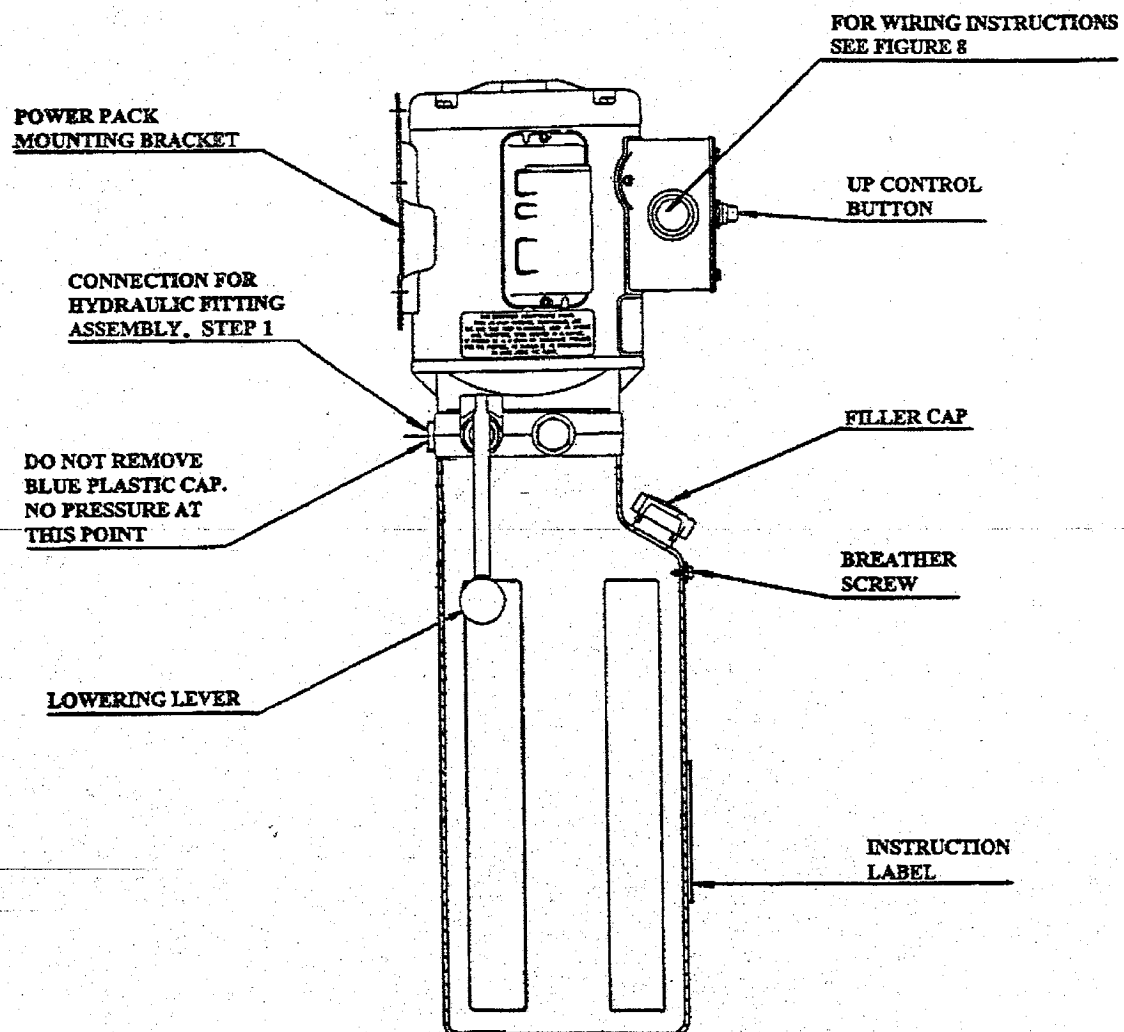

ELECTRICAL DIAGRAM

Figure 8

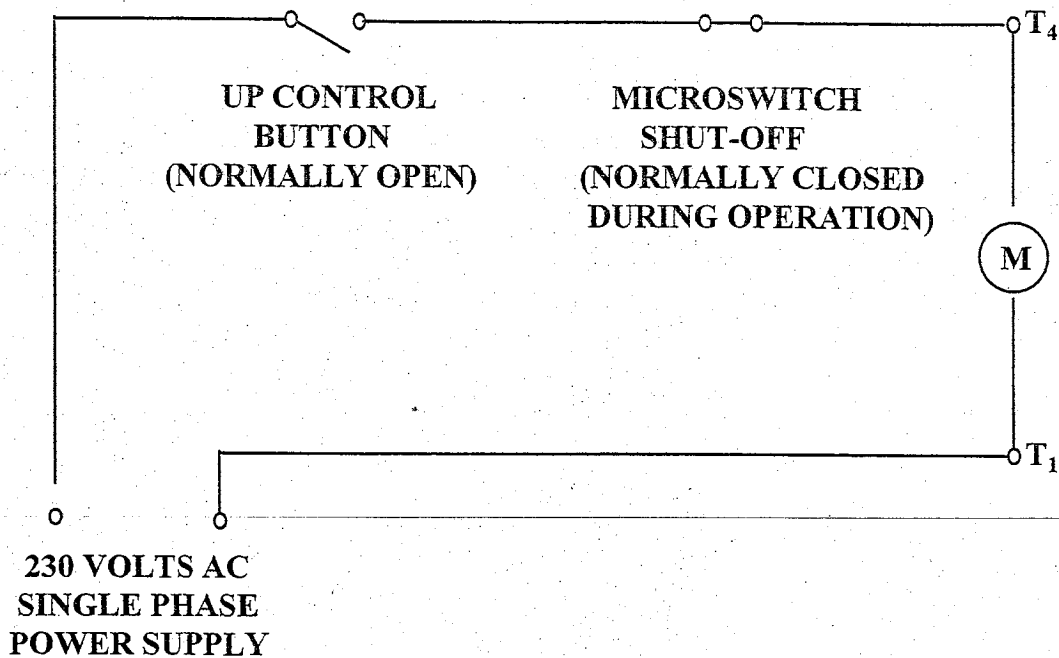

HYDRAULIC SYSTEM CONNECTIONS

Figure 9

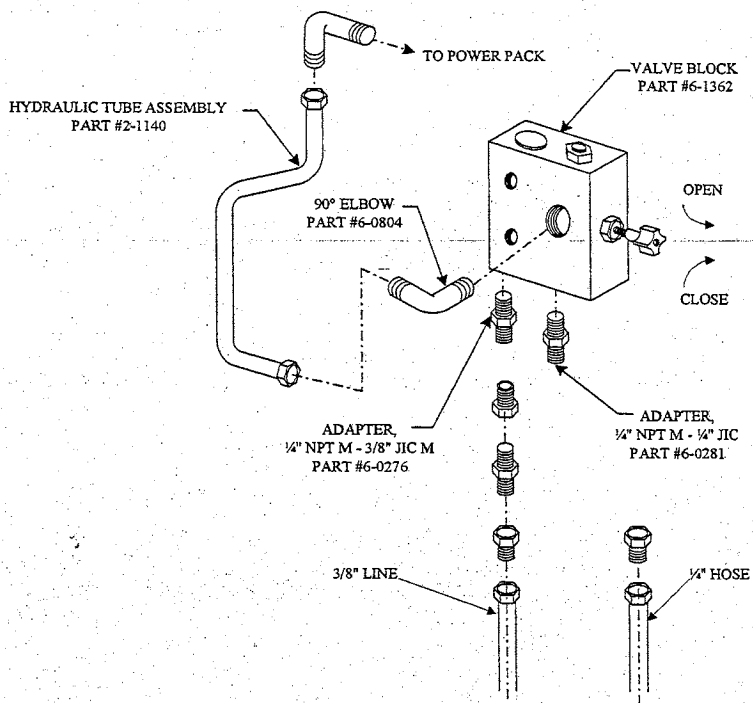

5.7 HYDRAULIC SYSTEM INSTALLATION

Refer to **Figure 9** and **10**, and page 28 on the Hydraulic System Part List.

Note: Save hydraulic caps and plugs for future use.

1. Do not tighten any hydraulic fittings until all connections have been made.
2. Remove plug from item 17. Install item 17 (page 28) to the 90° fitting on the power pack (item 18).
3. Install the valve block to the power side tower using items 23 & 5.
4. On the power side cylinder, remove the cap off item 28 at the bottom rear and install item 27.
5. Attach item 27 to item 53 on the valve block.
6. At the bottom of the power side cylinder, remove the 1/4" cap from item 25 and attach it to item 51 on valve block.
7. Attach the other end of item 17 to the 90° fitting (item 18) on the valve block.
8. Remove the two caps on item 39 and place it in the crossmember. Connect the slave side end of this line to a bulkhead fitting (item 1) attached to the hydraulic line (item 6).
9. Connect the power side end to the bulkhead fitting (item 1) attached to the hydraulic line (item 30).
10. TIGHTEN ALL HYDRAULIC CONNECTIONS.
Caution: Over tightening could cause the flare seal to break.
11. Remove filler cap from power pack, and fill reservoir with 3.5 Gal. (13.2 L) of ISO32 hydraulic oil (10 weight hydraulic oil). Remove breather screw when filling and replace when full. Refer to **Figure 7**.

HYDRAULIC SYSTEM SCHEMATIC

Figure 10

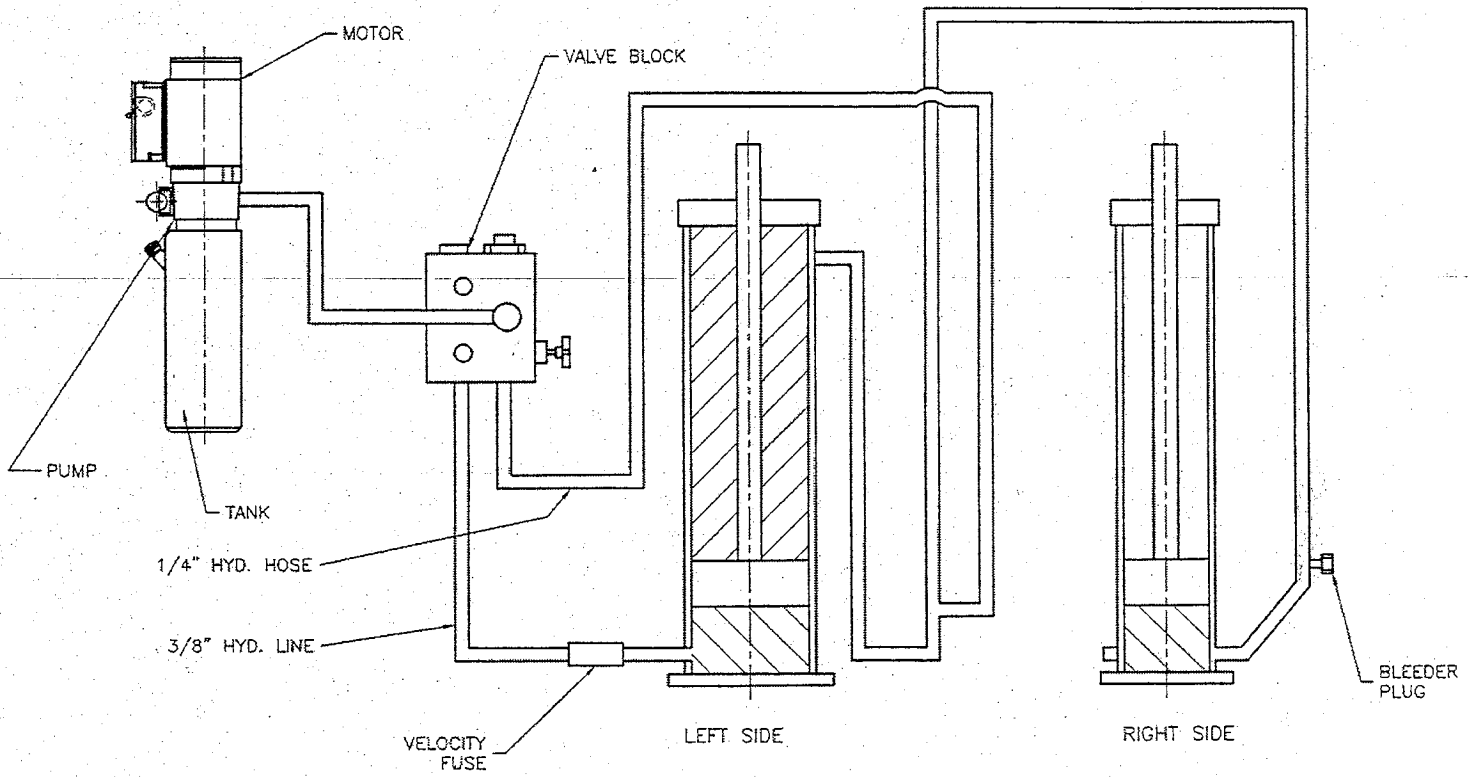

5.8 SAFETY RELEASE CABLE ROUTING AND ADJUSTMENT

The mechanical safety automatically engages. To release the mechanical safety, you must first raise the lift approximately 2", then pull the safety release lever down. This disengages the power side safety dog and activates the safety cable to release the slave side safety dog.

1. Refer to **Figure 11** for safety release cable routing. The cable end which has a collar belongs to the slave side tower. The threaded end belongs to the power side tower.
2. Start routing from the slave side of crossmember. Feed the cable over the small pulley, then guide the cable down along the inside of the slave side roll formed tower channel. Pull the cable out through the opening in the back of the slave side tower near the safety dog.
3. Guide the cable up under the pulley towards the end of the safety dog. Use a 1/4" shoulder bolt to mount the collar end of the cable to the safety dog. Tighten the shoulder bolt securely.
4. Repeat step 2 for the power side tower.
5. Install one 1/4"-20unc hex nut on the threaded end of the cable. Feed the threaded end of the cable through the hole in the bracket attached at the end of the safety dog. Install another 1/4"-20unc hex nut as shown in **Figure 12**. **Do not tighten at this stage.**
6. Install safety release handle onto the power side safety dog. Lock into position using one 1/2"-13unc hex nut.
7. Adjust the safety release cable on the power side mechanism by loosening the two
8. hex nuts so that the cable lengths can be adjusted. Adjust cable lengths so that both safety dogs travel from full engagement position to full release position when the safety
9. release handle is pulled. **Tighten both hex nuts against the bracket firmly when adjustment is completed.**

SAFETY RELEASE CABLE ROUTING AND ADJUSTMENT

Figure 11

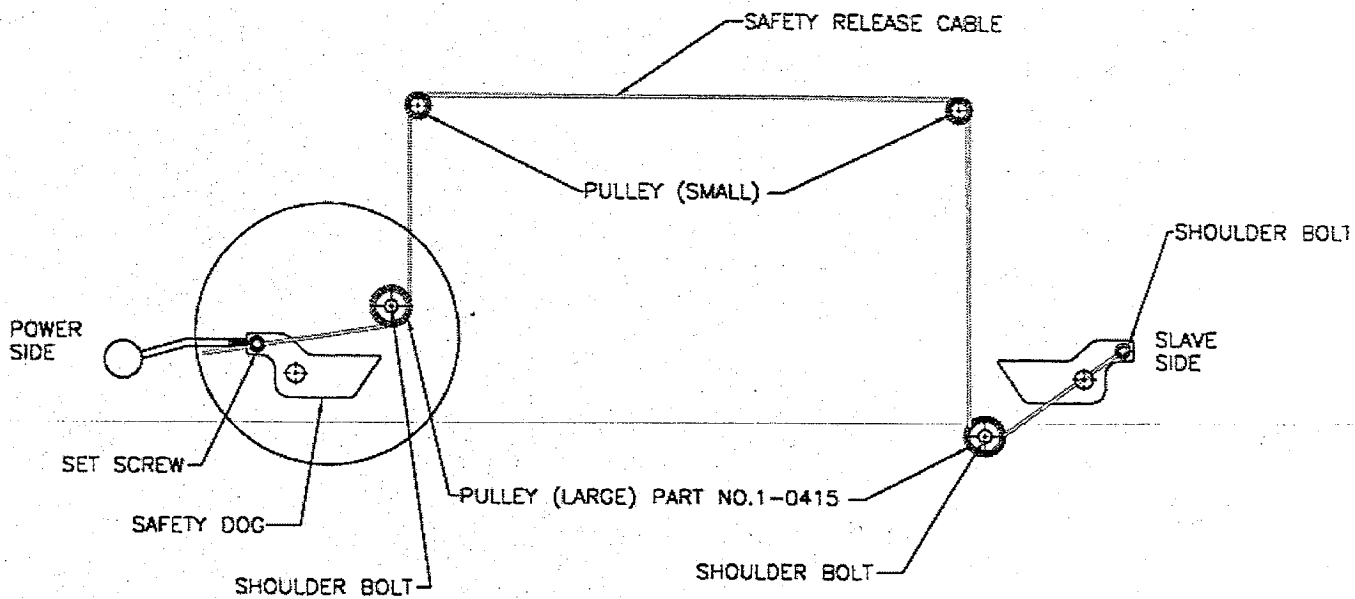
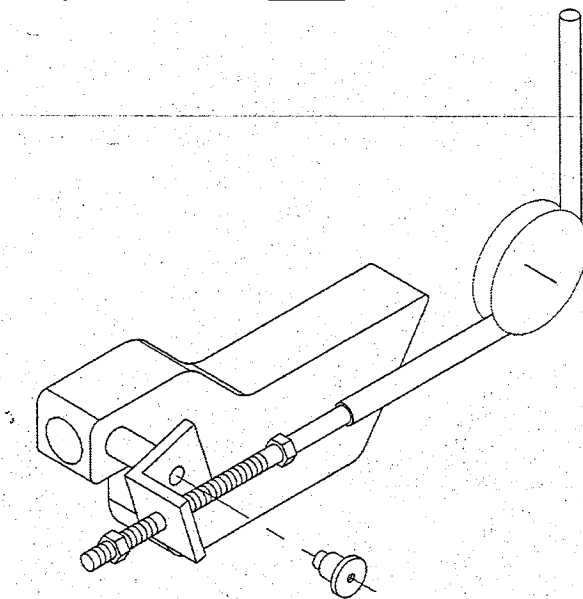

Figure 12

POWER SIDE



5.9 HYDRAULIC SYSTEM BLEEDING AND LEVELING PROCEDURE

1. Ensure that both carriages are fully lowered.
2. Remove the bleeder cap from the "T" fitting at the bottom of the slave side cylinder.
3. Attach a 15ft. clear bleeding hose to the same fitting, and place the open end of the hose into the power pack's reservoir's filler neck or in a container in which the oil came in for reuse. Hose should be secured during the bleeding procedure.
4. Close the by-pass valve, and power up until the power side carriage reaches the carriage stops.
5. Open the by-pass valve, and power up until oil is seen flowing out of the bleeder hose. (No Air Bubbles). Bleed at least 1 gal. of hydraulic fluid through the system.
6. Remove the bleeding hose and reinstall the bleeder cap. Replace breather/filler cap.
7. Power up until slave side carriage reaches the carriage stops.
8. Close the by-pass valve and lower lift (both sides) until both carriages are fully collapsed. Power up and lower (14") lift a few times. When lift is fully down, open the by-pass valve and raise the slave side 2-3" higher than the power side. Close the by-pass valve.
9. Power up, and lower lift onto the first safety, on the power side. Open the by-pass valve and lower slave side onto the same first safety. Close the by-pass valve. Lift is now synchronized hydraulically.
10. Both power and slave sides must be completely down.
11. Check and add hydraulic fluid to power pack before cycling lift.
12. Install safety covers, and safety release lever knob. Securely.
13. Set up a vehicle on the lift after anchoring to make sure hydraulics are operating properly.

5.10 HYDRAULIC ADJUSTMENT PROCEDURE

Important! Should your lift come out of synchronization, i.e. one carriage is higher than the other, it is necessary to level the lift hydraulically.

When **slave** side is **higher** than the power side:

1. Lower lift on to the first safety on the power side.
2. Open by-pass valve. Push the down control lever. This will cause the slave side carriage to be lowered. Stop lowering when the slave side carriage stops on the first safety.

When **power** side is **higher** than the slave side:

1. Open the by-pass valve, raise lift until the slave side carriage is approximately 1-2" higher than the power side carriage. Stop raising and close by-pass valve.
2. Lower lift by pushing the down control lever. Stop lowering when the power side carriage touches the first safety.
3. Next, open the by-pass valve. Push the down control lever so that the slave side carriage lowers. Stop lowering when the slave side carriage touches the first safety. Close the by-pass valve.

5.12 TOWER POSITIONING AND ANCHORING

WARNING! Failure to follow these instructions may cause an unsafe operating condition.

WARNING! Before proceeding with installation, review Section 4: Installation & Tools.

1. Using a 4ft. level on top of the crossmember, determine which column is higher (Fig. 13).
2. Using 2 ft. level on the sides of the high column, ensure that the column is level in the vertical position (Fig. 14). Use shims under the column baseplate to hold the column level. Ensure that the base plate is completely supported by shims where it does not contact the floor (Fig. 15).

WARNING! Do not use more than $\frac{1}{2}$ " (13mm) of shims. Anchor bolts supplied allow for a maximum of $\frac{1}{2}$ " (13mm) of shim. If more than $\frac{1}{2}$ " (13mm) of shims are required, **DO NOT** proceed with installation and contact Product Manufacturer / Supplier for further details.

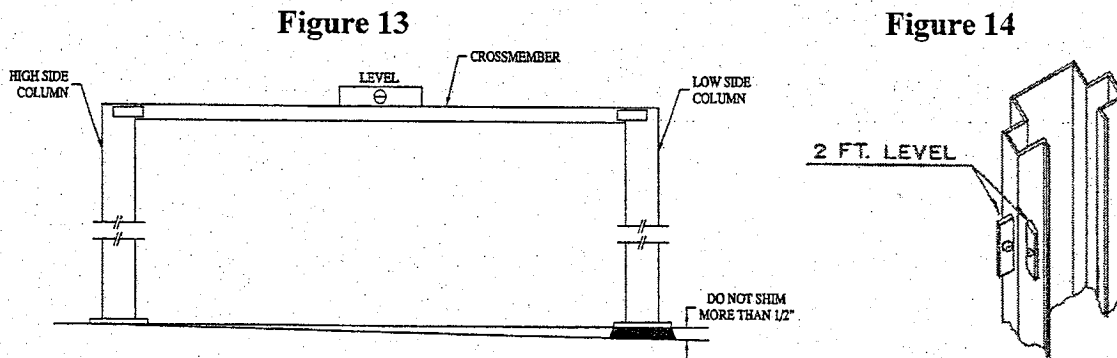

Figure 15

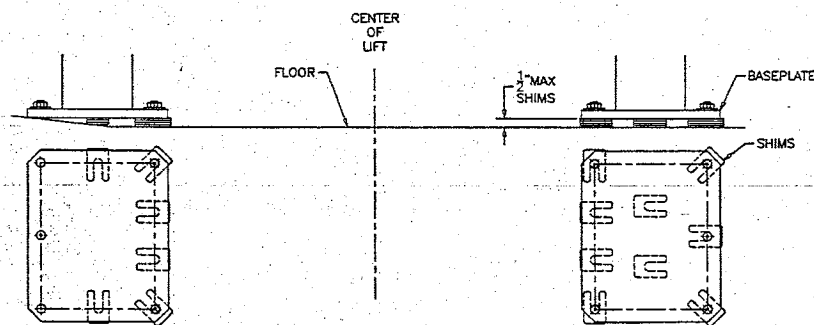
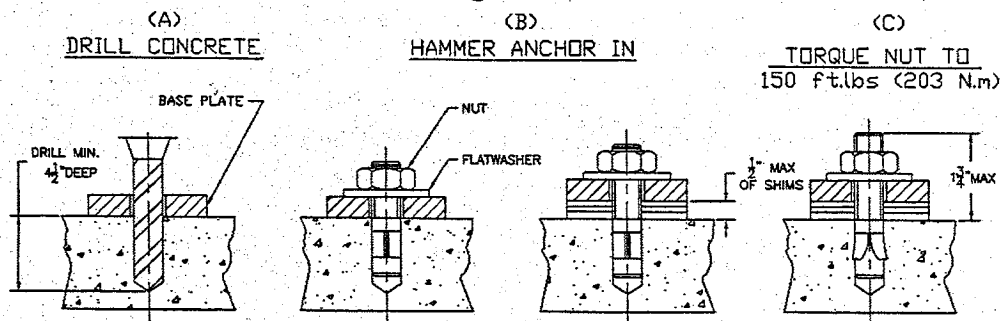

Figure 16



3. Refer to Bay Layout (**Fig. 3**) to ensure that the column is still in the proper position. Using a rotary hammer drill with a 3/4" masonry drill bit, drill holes in the floor on the high side column using the tower baseplate as a template. Make sure that the 3/4" masonry drill is in good condition (**Fig 16 (A)**).
4. Carefully clean out drilling dust from the anchor holes. Hammer in the anchor bolts (**Fig. 16(B)**). Hand tighten all anchor bolts.
5. Reconfirm that the column is level front to rear and side to side (**Fig. 14**). Add or remove shims as required.
6. Torque all anchor bolts to 150 ft-lbs. (203 Nm), continually checking that the column is level as you proceed. If anchor bolts do not tighten to 150 ft-lbs. OR project more than 1 3/4" above the concrete surface (**Fig 16(C)**), the concrete MUST be replaced by an appropriate concrete pad. (*Consult Product Manufacturer / Supplier for further details*).

5.13 SHIMMING OF THE REMAINING TOWER

1. Using a 4ft. level on the crossmember (**Fig. 13**) and a 2ft. level on the low side column (**Fig. 14**), shim underneath the baseplate until the crossmember and column are level. Ensure that the baseplate is completely supported by shims where it does not contact the floor (**Fig 15**).

WARNING! *Do not use more than 1/2" (13mm) of shims. Anchor bolts supplied allow for a maximum of 1/2" (13mm) of shim. If more than 1/2" (13mm) of shims are required, DO NOT proceed with installation and contact Product Manufacturer / Supplier for further details.*

2. Refer to Bay Layout (**Fig. 3**) to ensure that the column is still in the proper position. Using a rotary hammer drill with a 3/4" masonry drill bit, drill holes in the floor on the low side column using the column baseplate as a template. Make sure that the 3/4" masonry drill is in good condition (**Fig 16 (A)**).
3. Carefully clean out drilling dust from the anchor holes. Hammer in the anchor bolts (**Fig. 16(B)**). Hand tighten all anchor bolts.
4. Reconfirm that the crossmember is level (**Fig. 13**) and that the column is level front to rear and side to side (**Fig. 14**). Add or remove shims as required.
5. Torque all anchor bolts to 150 ft-lbs. (203 Nm), continually checking that the crossmember and column are level as you proceed. If anchor bolts do not tighten to 150 ft-lbs. OR project more than 1 3/4" above the concrete surface (**Fig 16(C)**), the concrete MUST be replaced by an appropriate concrete pad. (*Consult Product Manufacturer / Supplier for further details*).
6. Verify that the entire lift is level both horizontally and vertically to ensure optimum lifting performance.

***Perform a monthly inspection and torque all anchor bolts to 150 ft-lbs. (203 Nm).**

3.13 ARM LOCKS ADJUSTMENT

The arm locks are designed to automatically engage when the lift is raised and disengage when the lift is fully lowered. To adjust, refer to **Figure 17**.

ARM LOCK ADJUSTMENT

Figure 17

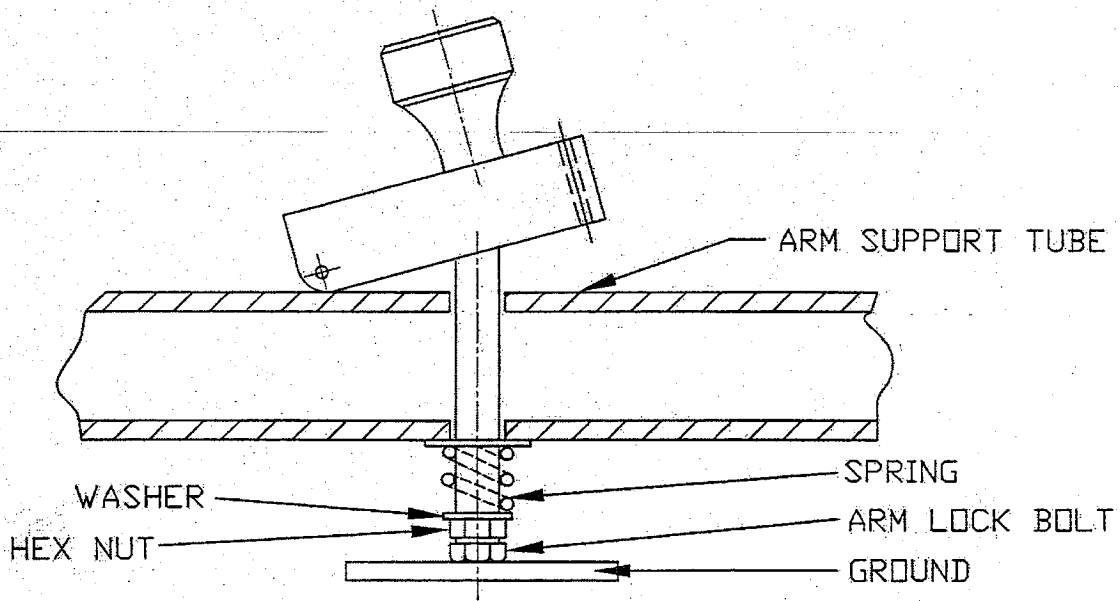

6. PERIODIC MAINTENANCE

1. Inspect lift daily, to assure the mechanical safety is operating properly.
2. Check the telescopic arms for movement. Clean any grease or oil from the lifting adapters.
3. Raise and lower the lift at the beginning of each shift, without a vehicle on, to verify the lift is leveled and operating properly. Perform hydraulic leveling procedure when the lift is out of level.
4. Lubricate safety dog mechanisms with penetrating oil monthly.
5. Grease arm pins supports monthly.
6. Check hydraulic fittings for tightness.
7. Annual lift inspection as per Automotive Lift Operation, Inspection and Maintenance (ALOIM).
8. Apply a small amount of grease to glide bearing tracks periodically.
9. Check bolts on the carriage stops for tightness. Note: The carriage stop on the slave side tower should have the thicker side facing downwards, and on the power side facing upwards. Refer to **Figure 18**.

Figure 18

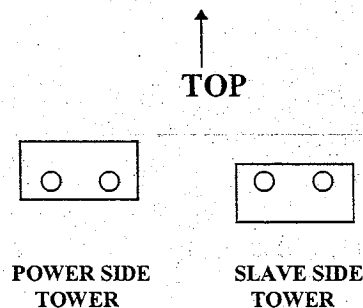

10. Check lift for synchronization periodically.
11. Change hydraulic oil every two years.

NOTE: If lift locks while in the fully raised position this will indicate that the hydraulic system has not been inspected or maintained as recommended. This is a safety back-up system. If you are unclear call your local representative immediately.

7. SAFETY AWARENESS - AUTOMOTIVE LIFT INSTITUTE (ALI)

<p>⚠ WARNING Clear area if vehicle is in danger of falling.</p>	<p>⚠ WARNING Position vehicle with center of gravity midway between adapters.</p>	<p>⚠ CAUTION Lift to be used by trained operator only.</p>	<p>⚠ CAUTION Authorized personnel only in lift area.</p>	<p>SAFETY INSTRUCTIONS Read operating and safety manuals before using lift.</p>	<p>SAFETY INSTRUCTIONS Proper maintenance and inspection is necessary for safe operation.</p>
					<p>The messages and pictographs shown are generic in nature and are meant to generally represent hazards common to all lifts of this type regardless of specific style.</p> <p>Funding for the development and validation of these safety signs provided by the Automobile Lift Institute, P.O. Box 33118, Indianton, FL 32903-3118. They are protected by copyright. Set of labels may be obtained from ALI or its member companies.</p>
<p>⚠ WARNING Remain clear of lift when raising or lowering vehicle.</p>	<p>⚠ WARNING Avoid excessive rocking of vehicle while on lift.</p>	<p>⚠ CAUTION Use vehicle manufacturer's lift points.</p>	<p>⚠ CAUTION Always use safety stands when removing or installing heavy components.</p>	<p>SAFETY INSTRUCTIONS Do not operate a damaged lift.</p>	
<p>⚠ WARNING Do not override self-closing lift controls.</p>	<p>⚠ WARNING Keep feet clear of lift while lowering.</p>	<p>⚠ CAUTION Use height extenders when necessary to ensure good contact.</p>	<p>⚠ CAUTION Auxiliary adapters may reduce load capacity.</p>	<p>Warning Labels for 2-post surface mounted lifts. Daily review of these Safety Messages and Warnings is suggested.</p>	

TWIN POST PARTS LIST

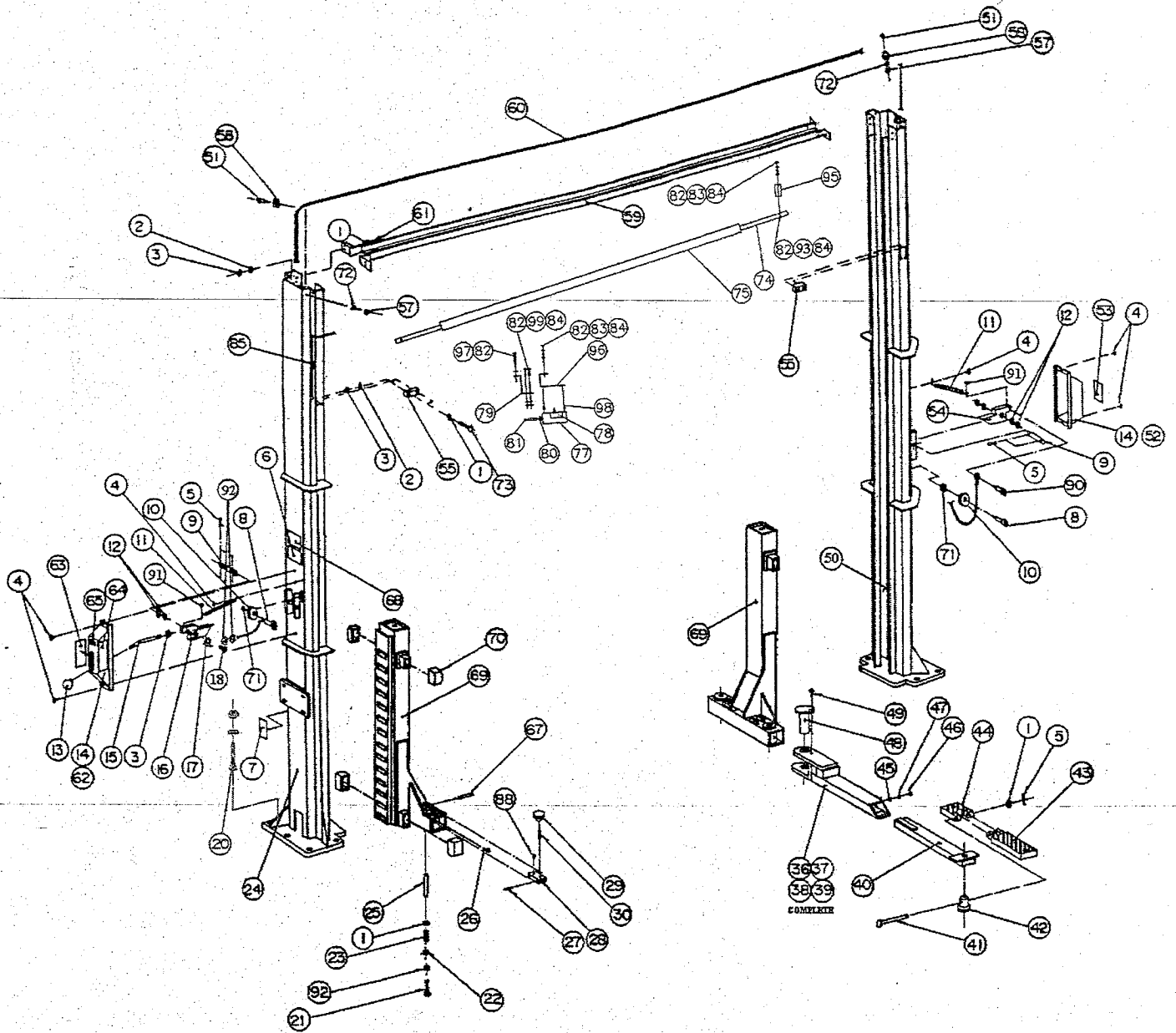

TWIN POST PART LIST

ITEM	QTY.	DESCRIPTION	PART #
1	24	FLAT WASHER, 1/2"ID SAE	6-0248
2	16	LOCKWASHER, 1/2"ID	6-0059
3	17	HEX NUT, 1/2"-13UNC	6-0035
4	6	SELF TAPPING SCREW, #12 x 1/2"LG.	6-1134
5	8	COTTER PIN, 1/8"DIA. x 1"LG.	6-0267
6	1	ALI/ETL DECAL	6-0996
7	1	"HYDRAULIC LEVELING " DECAL	6-1583
8	2	SHOULDER BOLT, 3/8"DIA. x 1"LG.	6-0206
9	2	SAFETY PIN	1-0938
10	2	SAFETY PULLEY	1-0415
11	2	SAFETY SPRING	1-1115
12	8	FLAT WASHER, 51/64"ID x 1"OD x 1/16"THK.	6-0808
13	1	PLASTIC KNOB	6-1135
14	2	SAFETY COVER	3-0439
15	1	SAFETY RELEASE HANDLE	1-1113
16	1	SAFETY DOG, POWER SIDE	2-0902
17	1	CABLE CONNECTING BRACKET	1-1291
18	4	COTTER PIN, 1/8" x 2"LG.	6-0115
20	10	WEDGE ANCHOR, 3/4"-10UNC x 5 1/2"LG. (c/w washers & nuts)	6-1379
21	4	HEX BOLT, 1/4"-20UNC x 2"LG.	6-0741
22	4	1/4"ID FENDER WASHER	6-0626
23	4	PLUNGER SPRING	1-0939
24	1	TOWER WELDMENT, LEFT SIDE	4-0621
25	4	PIVOT PLUNGER	1-0745
26	4	GREASE FITTING	6-0000
27	4	ROLL PIN, 1/8"DIA. X 1"LG.	6-0437
28	4	RACK	2-0249
29	4	KNOB	1-0208
30	4	THREADED ROD, 3/8"-16UNC x 1 1/2"LG.	1-1135
36	2	LONG OUTER ARM TUBE WELDMENT, F.L., R.R.	3-0657
37	2	LONG OUTER ARM TUBE WELDMENT, F.R., R.L.	3-0656
38	2	LONG LOCKING ARM ASSEMBLY, F.L., R.R.	4-0616
39	2	LONG LOCKING ARM ASSEMBLY, F.R., R.L.	4-0617
40	4	LONG INNER ARM WELDMENT	2-1273
41	4	CENTER PIN	1-1099
42	4	ADAPTER PIN	1-1091
43	4	HIGH STEP POSITION ADAPTER	3-0582
44	4	LOW POSITION ADAPTER	3-0583
45	4	FLATWASHER, 3/8"ID.	6-0062
46	4	HEX BOLT, 3/8"-16UNC x 3/4"LG.	6-0030
47	4	LOCKWASHER, 3/8"ID.	6-0058
48	4	ARM PIN WELDMENT	2-0929

ITEM	QTY.	DESCRIPTION	PART #
49	4	HEX BOLT, 5/16"-18UNC x 3/4"LG.	6-0423
50	1	TOWER WELDMENT, RIGHT SIDE	4-0620
51	2	SHOULDER BOLT, 3/8"DIA. x 5/8"LG.	6-0069
52	1	SAFETY COVER w/DECALS, SLAVE SIDE	0-0203
53	1	"SAFETY INSTRUCTIONS" DECAL	6-0594
54	1	SAFETY DOG, SLAVE SIDE	2-0872
55	4	CARRIAGE STOP	1-1119
57	2	HEX NUT, 5/16"-18UNC	6-0294
58	2	SAFETY CABLE PULLEY	1-1116
59	1	CROSSMEMBER WELDMENT	2-1281
60	1	SAFETY RELEASE CABLE, 341 1/2"LG.	1-1647
61	8	HEX BOLT, 1/2"-13UNC x 1 1/4"LG.	6-0046
62	1	SAFETY COVER w/DECALS, POWER SIDE	0-0204
63	1	"WARNING" DECAL	6-0595
64	1	"CAUTION" DECAL	6-0592
65	1	"SAFETY RELEASE" DECAL	6-0603
67	4	PIVOT PIN	1-0333
68	1	SERIAL # TAG	6-1172
69	2	CARRIAGE WELDMENT	4-0613
70	8	GLIDE BEARING	2-0772
71	2	FLAT WASHER, 5/16" I.D.	6-0295
72	2	LOCKWASHER, 5/16" I.D.	6-0296
73	8	HEX BOLT, 1/2" - 13UNC x 2 1/4"LG.	6-0315
74	1	ACTUATOR BAR	1-1439
75	1	FOAM GUARD	6-1404
77	1	ELECTRICAL UTILITY BOX	6-1403
78	1	MICROSWITCH	6-0916
79	1	ACTUATOR EXTENSION	1-1823
80	1	CABLE CONNECTOR	6-1133
81	1	ELEC. CABLE 16/3 x 141"LG.	6-1513
82	7	HEX HD. NUT 1/4"NC	6-0032
83	3	HEX HD. BOLT, 1/4"NC x 3/4"LG.	6-0178
84	6	LOCKWASHER 1/4" DIA	6-0056
85	3	ELECTRICAL CABLE CLIP, 3/8"	6-1230
88	4	SET SCREW., 1/4"-20UNC X 1/2"LG.	6-0438
90	1	SHOULDER BOLT, 3/8"DIA. X 1 1/2"LG.	6-0801
91	2	SELF-TAPPING SCREW, #10 X 3/8"LG.	6-0169
92	6	HEX NUT, 1/4"NC	6-0032
93	1	HEX HD. BOLT, 1/4"NC X 1 1/2"LG.	6-0205
95	1	ACTUATOR MTG. BRACKET	1-1378
96	1	LIMIT SWITCH MTG. BRACKET	2-1143
97	1	HEX HD. BOLT 1/4" - 20UNC X 2"LG.	6-0741
98	2	6/32 SCREW (ELECTRICAL BOX)	6-1466
99	2	HEX HD. BOLT, 1/4" NC x 1 1/4"LG.	6-0027

TWIN POST HYDRAULICS

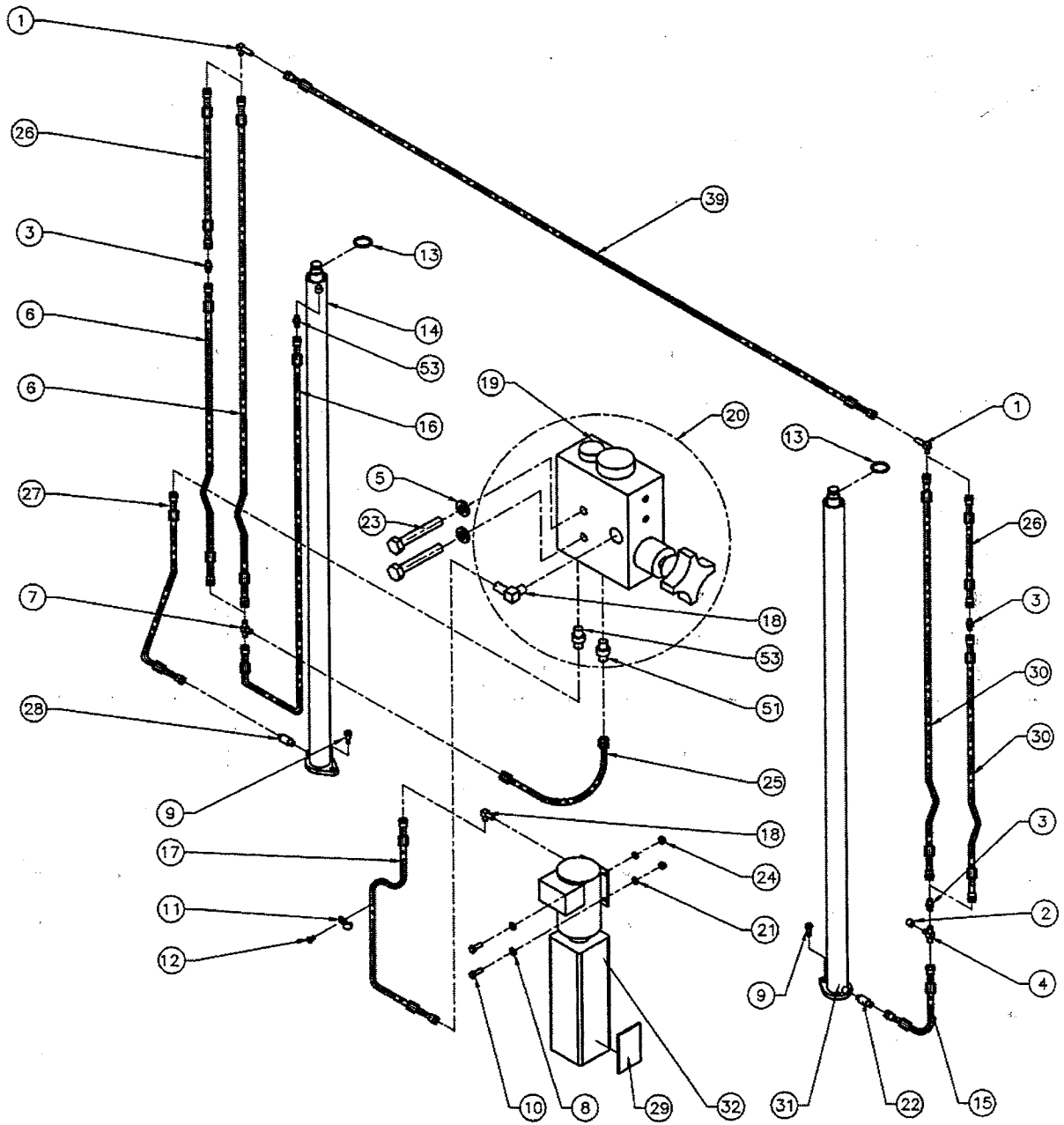

TWIN POST HYDRAULIC PART LIST

ITEM	QTY.	DESCRIPTION	PART #
1	2	ELBOW BULKHEAD 90°, 3/8"JIC-3/8"JIC	6-0012
2	1	CAP, 3/8"JIC	6-0021
3	3	UNION, 3/8"JIC MALE	6-0286
4	1	TEE, 3/8" SWIVEL NUT JIC MALE	6-0284
5	2	LOCKWASHER, 1/4" I.D.	6-0056
6	1	HYDRAULIC TUBE ASS'Y (2PC. TOWERS)	2-0719
	1	HYDRAULIC TUBE ASS'Y (12FT. TOWERS)	2-0961
	1	HYDRAULIC TUBE ASS'Y (14FT. TOWERS)	2-1065
7	1	BRANCH "T" JIC ALL ENDS	6-1372
8	4	FLAT WASHER, 5/16"ID	6-0061
9	2	SHOULDER BOLT, 1/2" x 5/8"LG.	6-0425
10	4	HEX BOLT, 5/16"-18UNC x 1"LG.	6-0293
11	7	TUBE CLAMP	6-0170
12	7	ROUND HD. BOLT, 1/4"-20UNC x 3/8"LG.	6-1353
13	2	CIRCLIP	6-0340
14	1	HYDRAULIC CYLINDER ASS'Y, LEFT SIDE	4-0289
15	1	HYDRAULIC TUBE ASS'Y	1-0102
16	1	HYDRAULIC TUBE ASS'Y	2-0887
17	1	HYDRAULIC TUBE ASS'Y	2-1140
18	2	ELBOW 90°, 9/16"SAE M-3/8"JIC M	6-0804
19	1	HYDRAULIC VALVE BLOCK	6-1362
20	1	HYDRAULIC VALVE BLOCK ASS'Y (C/W FITTINGS)	6-1389
21	4	LOCKWASHER, 5/16"ID	6-0674
22	1	ADAPTER, 3/8"NPT - 3/8"JIC x 2 1/4"LG.	6-0345
23	2	HEX HD. BOLT, 1/4"-20UNC x 1 3/4"LG.	6-0028
24	4	HEX NUT, 5/16"-18UNC	6-0294
25	1	HYDRAULIC HOSE ASS'Y	1-1341
26	2	HYDRAULIC TUBE ASS'Y (2PC. TOWERS)	2-0878
27	1	HYDRAULIC TUBE ASS'Y	2-0886
28	1	VELOCITY FUSE, 4GPM	6-0422
29	1	"LIFT OPERATION" DECAL (8K)	6-1265
	1	"LIFT OPERATION" DECAL (9K)	6-1639
	1	"LIFT OPERATION" DECAL (11K)	6-1266
30	1	HYDRAULIC TUBE ASS'Y (2PC. TOWERS)	2-0716
	1	HYDRAULIC TUBE ASS'Y (12FT. TOWERS)	2-0960
	1	HYDRAULIC TUBE ASS'Y (14FT. TOWERS)	2-1064
31	1	HYDRAULIC CYLINDER ASS'Y, RIGHT SIDE	3-0735
32	1	POWER PACK (8K)	6-1956
	1	POWER PACK (9K)	6-1957
	1	POWER PACK (11K)	6-1176
39	1	HYDRAULIC TUBE ASS'Y (8/9K)	2-1537
	1	HYDRAULIC TUBE ASS'Y (11K ASYM.)	2-0959
	1	HYDRAULIC TUBE ASS'Y (11K SYM.)	2-1286
51	1	ADAPTER, 1/4" NPT MALE - 1/4"JIC MALE	6-0281
53	2	ADAPTER, 1/4"NPT MALE - 3/8"JIC MALE	6-0276
		GLAND SEAL KIT, RIGHT SIDE (8/9/11K)	0-0551
		PISTON SEAL KIT, RIGHT SIDE (8/9/11K)	0-0159
		GLAND SEAL KIT, LEFT SIDE (8/9/11K)	0-0206
		PISTON SEAL KIT, LEFT SIDE (8/9/11K)	0-0160

POWER PACK

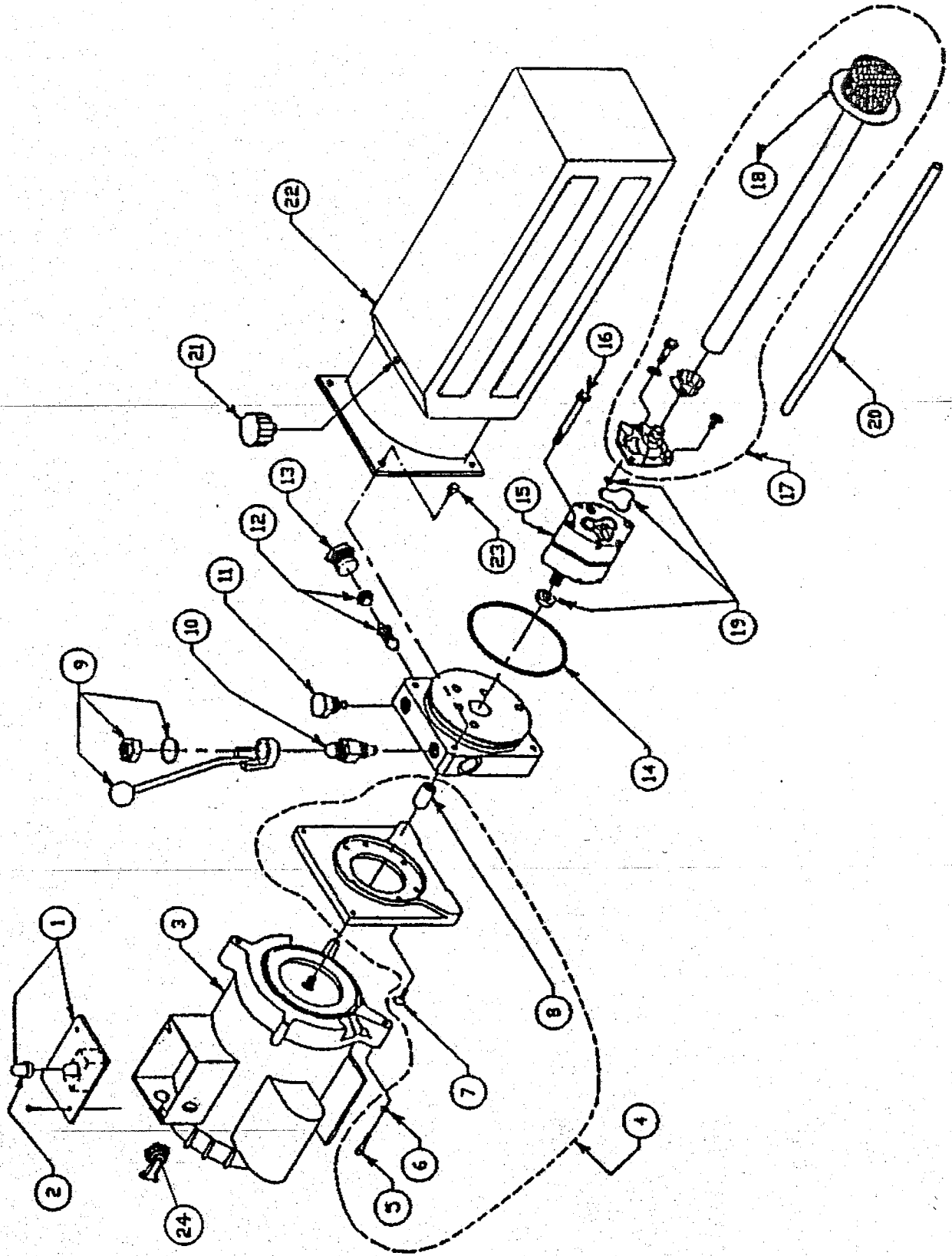

TWIN POST POWER PACK PART LIST

ITEM	QTY.	DESCRIPTION	PART #
1	1	MICROSWITCH	6-0881
2	1	MICROSWITCH BOOT	6-1084
3	1	MOTOR 230 VAC, 1PH, 60 HZ	6-0773
4	1	MOTOR ADAPTER	0-0197
5	4	SOCKET HD.CAP SCW, 1/4"-20UNC X 5/8"LG.	6-1085
6	4	LOCKWASHER, 1/4" I.D.	6-0056
7	4	ALLEN HD. FLAT SCW, 1/4"-20UNC X 3/4"LG.	6-1086
8	1	COUPLING	6-0774
9	1	RELEASE BRACKET & HANDLE ASSEMBLY	6-0776
10	1	VALVE CARTRIDGE RELEASE	6-0880
11	1	VALVE CARTRIDGE CHECK	6-1087
12	1	FIXED RELIEF VALVE, RV24	6-1324
13	1	RELIEF VALVE CAP	6-1089
14	1	RESERVOIR "O"RING	6-0875
15	1	PUMP ASSEMBLY	6-1960
16	2	PUMP MOUNTING BOLT	6-1090
17	1	INLET PLUMBING KIT	0-0198
18	1	INLET HOSE / FILTER ASSEMBLY	6-0786
19	1	PUMP "O" RING KIT	0-0199
20	1	RETURN TUBE	6-0783
21	1	BREATHER-FILLER CAP (PLASTIC)	6-1376
22	1	RESERVOIR (PLASTIC)	6-1399
23	4	RESERVOIR SCREW	6-1091
24	1	CABLE CONNECTOR, 3/8"	6-1133

Product Manual Approval Form

Issued by: HELON R.

Date: OCT. 13/99

Manual # 6-1617, 6-1616, 6-2117
6-2124

Manual Date: OCT. 1999

Product: 11168VS, 42011SS14, 63-189VS, DLS11014

Approval: *Helon R. R.*
Engineering Representative

Details of Change:

- NEW MANUAL FOR BEAR (#6-2117)
 - NEW MANUAL FOR HOFMANN (#6-2124)
 - NEW HYDRAULICS PARTS LIST.
-
-
-
-
-
-
-