



4-POST
MODEL 12405ST/12406ST
12000 LB.

**READ and SAVE THIS
INSTRUCTION MANUAL**

MAY 2012 REV.-

6-2628

WHEELTRONIC LTD.

6500 Millcreek Drive
Mississauga, Ontario, Canada
L5N 2W6
Phone: 1-800-268-7959
Fax: 905-826-7800

1.0 OWNER / EMPLOYER OBLIGATIONS

1. The Owner/Employer shall ensure that lift operators are qualified and that they are trained in the safe use and operation of the lift using the manufacturer's operating instructions; ALI/SM 93-1, **ALI Lifting it Right** safety manual; ALI/ST-90 **ALI Safety Tips** card; ANSI/ALI ALOIM-2008, **American National Standard for Automotive Lifts - Safety Requirements for Operation, Inspection and Maintenance, Appendix A (Operator Training Log)**; ALI/WL Series, **ALI Uniform Warning Label Decals/Placards**; and in the case of frame engaging lifts, ALI/LP-GUIDE, **Vehicle Lifting Points/Quick Reference Guide for Frame Engaging Lifts**.
2. The Owner/Employer shall establish procedures to periodically inspect the lift in accordance with the lift manufacturer's instructions or ANSI/ALI ALOIM-2008, **American National Standard for Automotive Lifts - Safety Requirements for Operation, Inspection and Maintenance, Appendix B and Appendixes C through F**; and the Employer shall ensure that the lift inspectors are qualified and that they are adequately trained in the inspection of the lift.
3. The Owner/Employer shall establish procedures to periodically maintain the lift in accordance with the lift manufacturer's instructions or ANSI/ALI ALOIM-2008, **American National Standard for Automotive Lifts - Safety Requirements for Operation, Inspection and Maintenance, Appendix G (Planned Maintenance Log)**; and the Employer shall ensure that the lift maintenance personnel are qualified and that they are adequately trained in the maintenance of the lift.
4. The Owner/Employer shall maintain the periodic inspection and maintenance records recommended by the lift manufacturer's instructions or ANSI/ALI ALOIM-2008, **American National Standard for Automotive Lifts - Safety Requirements for Operation, Inspection and Maintenance**
5. The Owner/Employer shall display the lift manufacturer's operating instructions; ALI/SM 93-1, **ALI Lifting it Right** safety manual; ALI/ST-90 **ALI Safety Tips** card; ANSI/ALI ALOIM-2008, **American National Standard for Automotive Lifts - Safety Requirements for Operation, Inspection and Maintenance**; ALI/WL Series, **ALI Uniform Warning Label Decals/Placards**; and in the case of frame engaging lifts, ALI/LP-GUIDE, **Vehicle Lifting Points/Quick Reference Guide for Frame Engaging Lifts** in a conspicuous location in the lift area convenient to the operator.
6. The Owner/Operator shall provide necessary lockout/tagout means for energy sources per ANSI Z244.1-1982 (R1993), **Safety Requirements for the Lockout/Tagout of Energy Sources**, before beginning any lift repairs and maintenance.
7. The Owner/Employer shall not modify the lift in any manner without the prior written consent of the manufacturer.



DO NOT ATTEMPT TO OPERATE THIS LIFT IF ANY PART IS NOT WORKING PROPERLY OR YOU HAVE NOT READ THE COMPLETE OPERATING INSTRUCTION MANUAL.

2.0 IMPORTANT SAFETY INSTRUCTIONS

When using this lift, basic safety precautions should always be followed, including the following:

1. Only trained and authorized personnel should operate the lift or rolling jacks. Do not allow customers or bystanders to operate the lift or be in the shop area while lift is in use.
2. Read all instructions in this manual and on the lift. Thoroughly train all employees in the use and care of lift and rolling jacks.
3. Inspect lift daily. Do not operate if it malfunctions or problems have been encountered.
4. Ensure no one is standing in front or behind the lift while vehicle is being driven onto, or backed off the lift.
5. Before driving vehicle on, make sure lift is in the fully down position.
6. Before removing the vehicle from the lift, make sure the lift is in the fully down position and ensure that all tools have been removed from the deck surfaces.
7. Always raise the lift off safety locks before lowering.
8. Do not allow rear tires or portion of the vehicle to interfere with approach ramp.
9. Be sure front wheel stops are always installed on the lift.
10. Never allow front wheels to strike the front wheel stops.
11. Do not permit employees or customers on lift when it is either being raised or lowered.
12. Never raise vehicle with passengers inside.
13. Always stand clear of lift when raising or lowering and observe "Pinch points" warning.
14. Before lowering the lift, check area for any obstructions
15. Never attempt to overload the lift. The manufacturer's rated capacity is shown on the identification label on the power side column.
16. Do not override the operating controls or safety mechanisms, or the warranty will be void. The mechanical safeties are designed to engage automatically on the way up.
17. Always use wheel chocks to keep the vehicle from rolling freely on the runways. Wheel chocks should be used at the front and back of the same wheel.
18. Always use Personal Protective Equipment (PPE) when installing or servicing the lift.
- 19. Caution! Never work under the lift unless the mechanical safety locks are engaged.**
20. Always keep the lift area free of obstruction, tools and debris. Grease and oil spills should always be cleaned up immediately.
21. Always keep runways clean.
22. To protect against the risk of fire, do not operate lift in the vicinity of open containers of flammable liquids.
23. Adequate ventilation should be provided when working on internal combustion engines.
24. Replace all caution, warning, or safety related decals on the lift when unable to read or missing.
25. For Rolling Jack Safety Instructions, see Rolling Jack Installation, Operation and Maintenance Instructions in the Rolling Jack box.

SAFETY INSTRUCTIONS

If attachments, accessories or configuration modifying components that are located in the

load path, affect operation of the lift, affect the lift electrical listing or affect intended vehicle accommodation are used on this lift and, if they are not certified for use on this lift, then the certification of this lift shall become null and void. Contact the participant for information pertaining to certified attachments, accessories or configuration modifying components.

www.autolift.org

©2007 by ALI, Inc.

ALI / WLSIAO1

TABLE OF CONTENTS**PAGE**

1.0	OWNER / EMPLOYER OBLIGATIONS.....	2
2.0	IMPORTANT SAFETY INSTRUCTIONS	3
3.0	GENERAL SPECIFICATION	6
4.0	TOOLS REQUIRED FOR INSTALLATION	6
5.0	CONTENTS	7
6.0	GENERAL LIFT SPECIFICATIONS	8
7.0	INSTALLATION INSTRUCTIONS	9
7.1	CHALK LINE LAYOUT	9
7.2	FRONT AND REAR CROSSMEMBER ASSEMBLY	11
7.3	SHEAVE INSTALLATION	12
7.4	CABLE INSTALLATION	13
7.5	POWER PACK INSTALLATION.....	15
7.6	ELECTRICAL CONNECTIONS	16
7.7	HYDRAULIC INSTALLATION	16
7.8	AIR INSTALLATIONS	17
7.9	SAFETY RETAINING SYSTEM	18
7.9	LEVELING PROCEDURE	19
7.9.1	LEVELING LIFT TO FLOOR.....	19
7.9.2	DECK LEVELING PROCEDURE	19
7.9.3	LEVELING PROCEDURE - SAFETY LADDERS.....	20
7.10	APPROACH RAMPS, WHEELSTOPS, PULLEY COVERS.....	21
7.11	ANCHOR INSTALLATION	21
7.12	SAFETY AND OPERATING INSTRUCTIONS.....	23
7.13	FINAL CHECK OF ASSEMBLED LIFT.....	24
7.14	OPERATION TEST WITH VEHICLE.....	25
8.0	RECOMMENDED INSPECTION AND MAINTENANCE	25
8.1	LUBRICATION SPECS	25
8.2	WIRE ROPES.....	27
8.2.1	WIRE ROPE CONDITIONS GUIDE.....	27
8.2.2	WIRE ROPE REPLACEMENT CRITERIA:	28
8.2.3	WIRE ROPE INSPECTION	28
8.2.4	WIRE ROPE LUBRICATION.....	28
8.2.5	WIRE ROPE ADJUSTMENT.....	28
8.2.6	INSPECT CABLE FLANGE.....	29
8.3	FASTENERS.....	29
8.4	SHEAVES AND PINS.....	29
8.4.1	VISUAL INSPECTION OF SHEAVES.....	29
8.4.2	MEASURE SHEAVE WEAR	29
8.4.3	SHEAVE PINS.....	30
8.5	MECHANICAL SAFETY LATCHES (DOGS)	30

8.6	CABLE BREAK SAFETY MECHANISM	30
8.7	AIR CYLINDERS, AIR LINES, VALVE AND FITTINGS	30
8.8	HYDRAULIC POWER PACK AND HOSE	30
8.9	HYDRAULIC CYLINDER	31
8.10	RUNWAYS	31
	8.10.1 CHECK RUNWAYS	31
	8.10.2 INSPECT JACK BEAM TRACKS	31
8.11	COLUMNS	31
	8.11.1 CHECK COLUMNS	31
	8.11.2 CHECK COLUMN ANCHORS	31
8.12	APPROACH RAMPS, CHOCKS, FRONT WHEEL STOPS	32
8.13	FRONT AND REAR STEER PLATES.....	32
	8.13.1 VISUAL INSPECTION	32
	8.13.2 CLEAN REAR SLIP PLATES AND FRONT TURN TABLES	32
	8.13.3 MAINTENANCE OF REAR STEER PLATES.....	32
	8.13.4 MAINTENANCE OF REAR STEER PLATES - IF EQUIPPED WITH PLASTIC BEARING CAGE.	32
	8.13.5 ANTI-SKID COATING ON REAR STEER PLATES	32
8.14	ROLLING AIR JACKS.....	33
8.15	ENTIRE LIFT	33
9.0	LIFT ASSEMBLY	34
10.0	HYDRAULIC AND AIR KITS ASSEMBLY.....	37
11.0	CABLE ROUTING DIAGRAM	39
12.0	SAFETY RETAINER BRACKET	41
13.0	POWER PACK: #6-1936 (AB-1400) 208-230V/1PH/60HZ.....	42

3.0 GENERAL SPECIFICATION

Maximum Capacity:	12000 lbs.	5443 kg
Overall Length:	235"	5969mm
Overall Width:	137"	3480mm
Down Position Height:	9.5"	241mm
Maximum Lifting Height:	71"	1803mm
Maximum Wheel Base:	144"	3658mm
Rise Time:	60 Seconds	
Power Rating:	230 Volts AC, 1Ph., 20 Amp, 60Hz.	
Air Requirements:	90-120 psi Shop Air	
Shipping Weight:	3450 lbs.	1565kg

CHECK CONTENTS OF ACCESSORY BOX WITH THE PACKING LIST ENCLOSED

4.0 TOOLS REQUIRED FOR INSTALLATION

ROTARY HAMMER DRILL
1/2" CONCRETE DRILL BIT
SOCKET FOR TIGHTENING ANCHORS
4' LEVEL
HAMMER (for anchor installation)
PRY BAR (for shim installation)
CHALK LINE (lift location)
FISH (mechanics wire to feed cable through crossmember assembly)
TAPE MEASURE
ELECTRICAL TAPE
STEP LADDER (adjusting cables and/or safety ladder in posts)
SIDE CUTTERS (for cutting shipping straps)
BAR (4' long)
4 WORK STANDS (set up)
STANDARD SOCKETS AND WRENCHES

IMPORTANT: It is the user's responsibility to provide a satisfactory installation area for the lift. Lifts should only be installed on level concrete floors with a minimum thickness of five (5) inches or 130 mm. Concrete must have a minimum strength of 4000 psi or 30 MPa and should be aged thirty (30) days prior to installation. Please consult the architect, contractor or engineer if doubt exists as to the strength and feasibility of the floor to enable proper lift installation and operation.

It is the user's responsibility to provide all wiring for electrical hook-up prior to installation and to insure that the electrical installation conforms to local building codes. Where required, it is the user's responsibility to provide an electrical isolation switch located in close proximity to the lift that will enable emergency stop capability and isolate electrical power from the lift for any servicing requirements.



ATTENTION! This lift is intended for indoor installation only. It is prohibited to install this product outdoors. Operating environment temperature range should be 41 – 104 °F (5 – 40 °C). Failure to adhere will result in decertification, loss of warranty, and possible damage to the equipment.

5.0 CONTENTS

The lift is packaged to protect from any damage that may occur in shipping. The two deck assemblies and crossmembers are packaged together with the accessory boxes strapped to them.

Main Structural Components:

- 1 - Left Side Deck Assembly (complete with hydraulic cylinder)
- 1 - Right Side Deck Assembly
- 1 - Front Crossmember Assembly (with air cylinder release locks and sheaves)
- 1 - Rear Crossmember Assembly (with air cylinder release locks and sheaves)

Accessory Box Components:

Box 1: Contents:

- 1 - Power Post (with safety ladder)
- 3 - Post (with safety ladder)

Box 2: Contents:

- 1 - Power Pack Assembly complete with Flow Control
- 2 - Approach Ramps
- 7 - Sheave Assemblies
- 1 - Set of Cables (set contains 4 cables with nuts and spacers)
- 7 - Sheave Spacers (different sizes)
- 2 - Front Wheel Stops
- 2 - Ramp Pins
- 4 - Deck Sheave Pins
- 1 - Air Kit (with 1/4" and 3/8" polytube and fittings)
- 1 - Hydraulic Hose (with fittings)
- 1 - Hose Guard
- 4 - Sheave Covers
- 3 - Cable Tie (for attachment of hydraulic hose to cylinder)
- 2 - Recoiled Air Hoses 12' long
- 1 - Coupler 1/4" NPT
- 1 - Package of Hardware (with its own packaging list)
- 1 - Owner's manual
- 1 - ALI manual "Lifting It Right"
- 1 - Automotive Lift Safety Tips
- 1 - Automotive Lift, Operation, Inspection and Maintenance manual

6.0 GENERAL LIFT SPECIFICATIONS

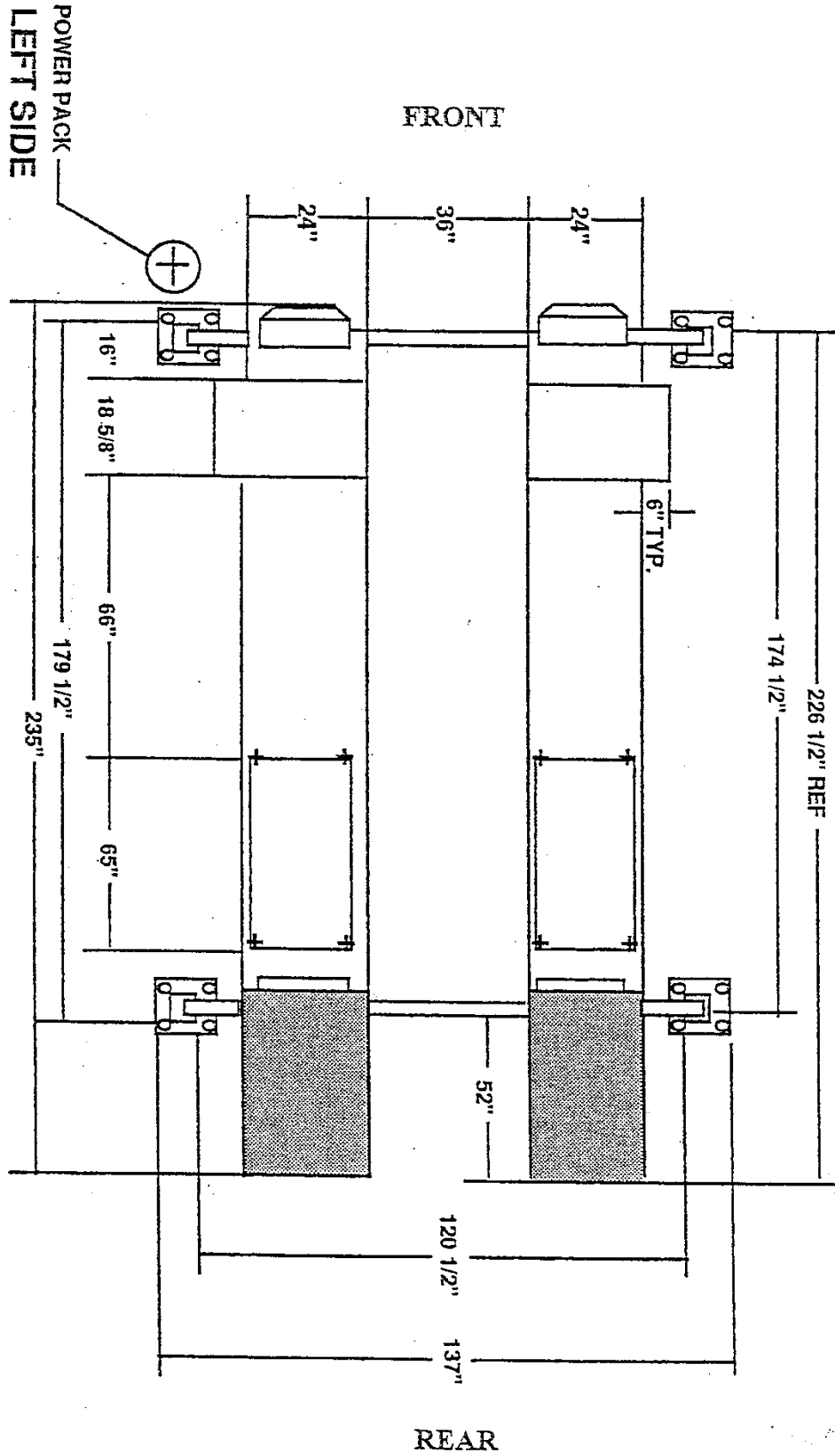

Figure 1

7.0 INSTALLATION INSTRUCTIONS

PLEASE TAKE THE TIME TO READ THESE INSTRUCTIONS COMPLETELY. A QUICK CHECK OF THE CONTENTS OF THE ACCESSORY BOX WOULD ALSO DECREASE THE OVERALL TIME OF THE INSTALLATION.

- Gather the tools and materials required for the installation.
- Select the location best suited for your lift.

NOTE: In determining lift area check for the following:

- Ease of driving a vehicle on and off the lift.
- Overhead obstructions, low ceiling height, overhead doors, overhead heaters, etc.
- Floor obstructions, uneven floor in lift area, floor drains, work benches, electrical in floor, etc.
- An outline matching the dimensions listed below will need to be marked on the floor. Refer to Figure 2 for outline dimensions. Refer to General Lift Specifications for overall lift dimensions. Figure 1.

7.1 CHALK LINE LAYOUT

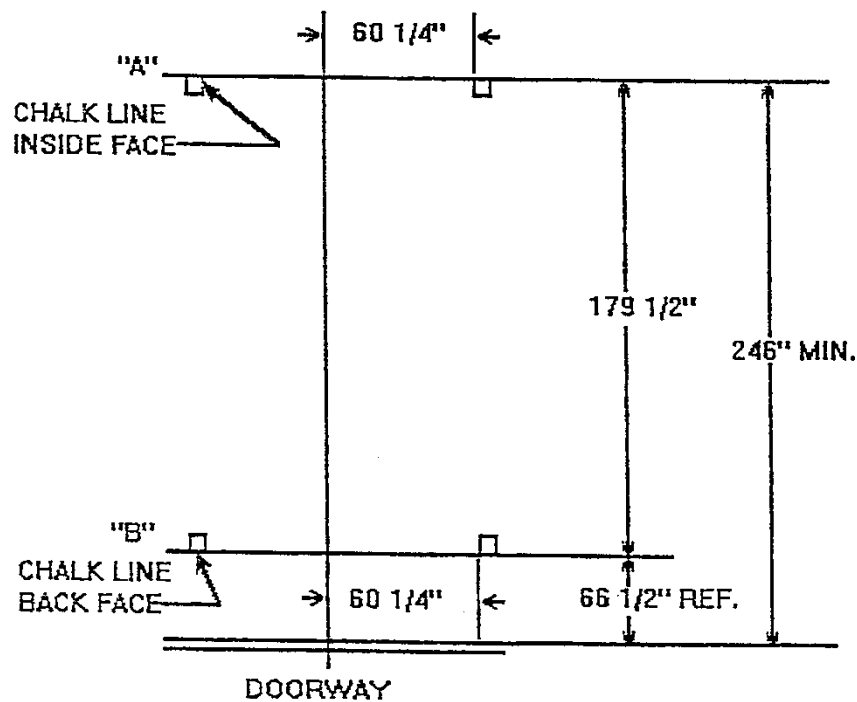

Figure 2

Refer to Figure 2. Make a chalk line parallel to the doorway at least 246 inches in from the doorway. This will be the furthest front face of the front post location. Call this line "A". Determine the center of the doorway and bay. Make a centerline to intersect with line "A". Measure from the centerline along line "A" 60 1/4 inches in both directions. This will be the location of the inside face and front face of the front posts. Measure back from this line "A" 179 1/2 inches. Make a chalk line parallel to line "A". Call this line "B". This will be the location for the back face of the rear posts. Measure from the centerline along line "B" 60 1/4 inches in both directions. This will be the location of the inside face and back face of the rear posts. Position work stands inside of line "A" and "B" of outline, to support the front and rear of each deck assembly.

IMPORTANT

NOTE: To determine the front, rear, left side and right side of the decks check the following:

- The left deck has the hydraulic cylinder mounted to its underside. The rear of the decks have approach ramp brackets to install the drive on approach ramps. The work steps, attached to the turn plate pocket cutouts will face towards the front outside of the lift.
- Position decks on work stands.

NOTE: To determine the front and rear crossmember assembly see Figure 3, and check the following:

- The front crossmember assembly will have two (2) small openings for the cable routing. The openings will face the rear of the lift.
- The rear crossmember assembly will have one (1) small opening and one (1) larger opening for cable routing. These openings will face the front of the lift.
- The crossmember assemblies are fully assembled and the PULLEYS DO NOT NEED TO BE REMOVED FOR CABLE INSTALLATION. ALIGN CROSS-MEMBER ASSEMBLIES SO THAT THE DIAGONALS MEASURE WITHIN HALF AN INCH SQUARE.
- Install the crossmember assemblies under the front and rear of each deck assembly. The decks will fit inside the locating tabs of the crossmember assemblies. Install eight (8) 1/2 - 13 UNC x 1" lg. set screws to hold the decks to the crossmember assemblies. One set screw to the front and rear of each deck and one set screw into the four outer locating tabs on the front and rear crossmember assemblies.
- Reposition work stands under front and rear crossmember assemblies.

7.2 FRONT AND REAR CROSSMEMBER ASSEMBLY

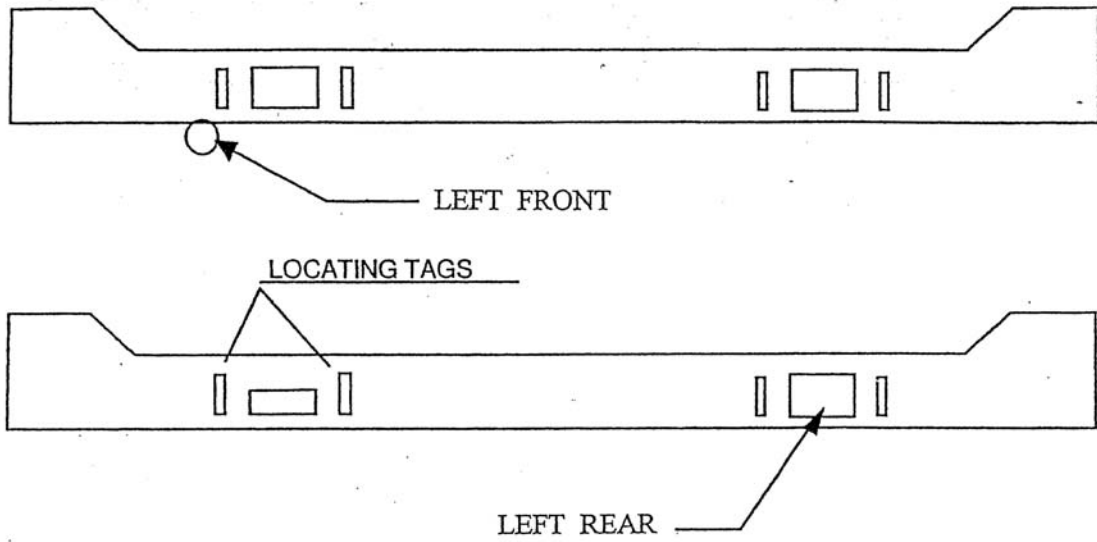

Figure 3

CABLE AND ROUTING IN CROSSMEMBER ASSEMBLY TYPICAL

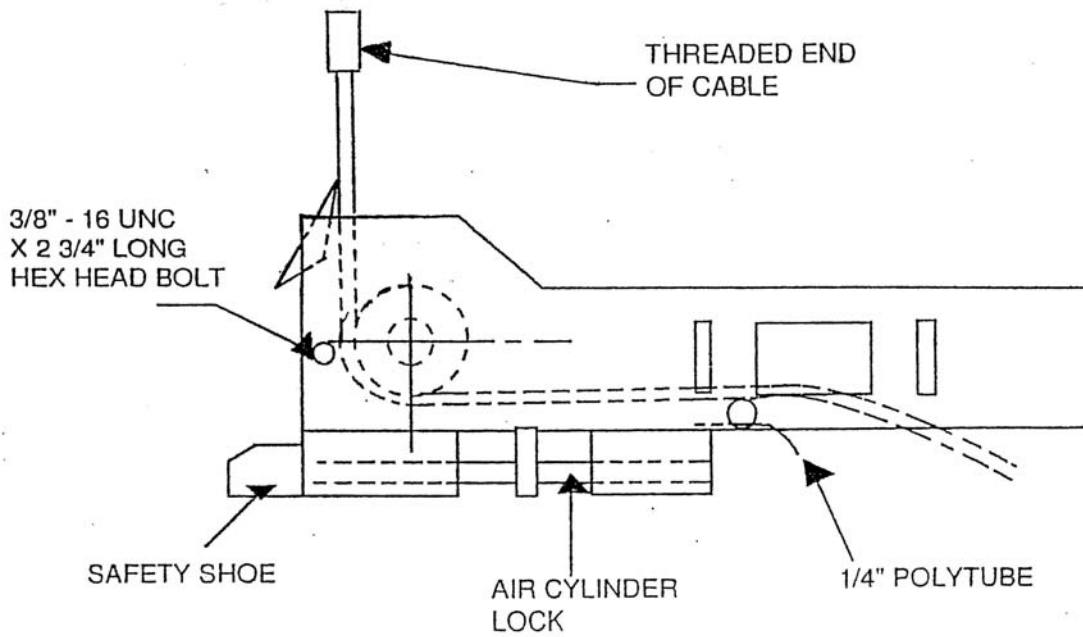

Figure 4

7.3 SHEAVE INSTALLATION

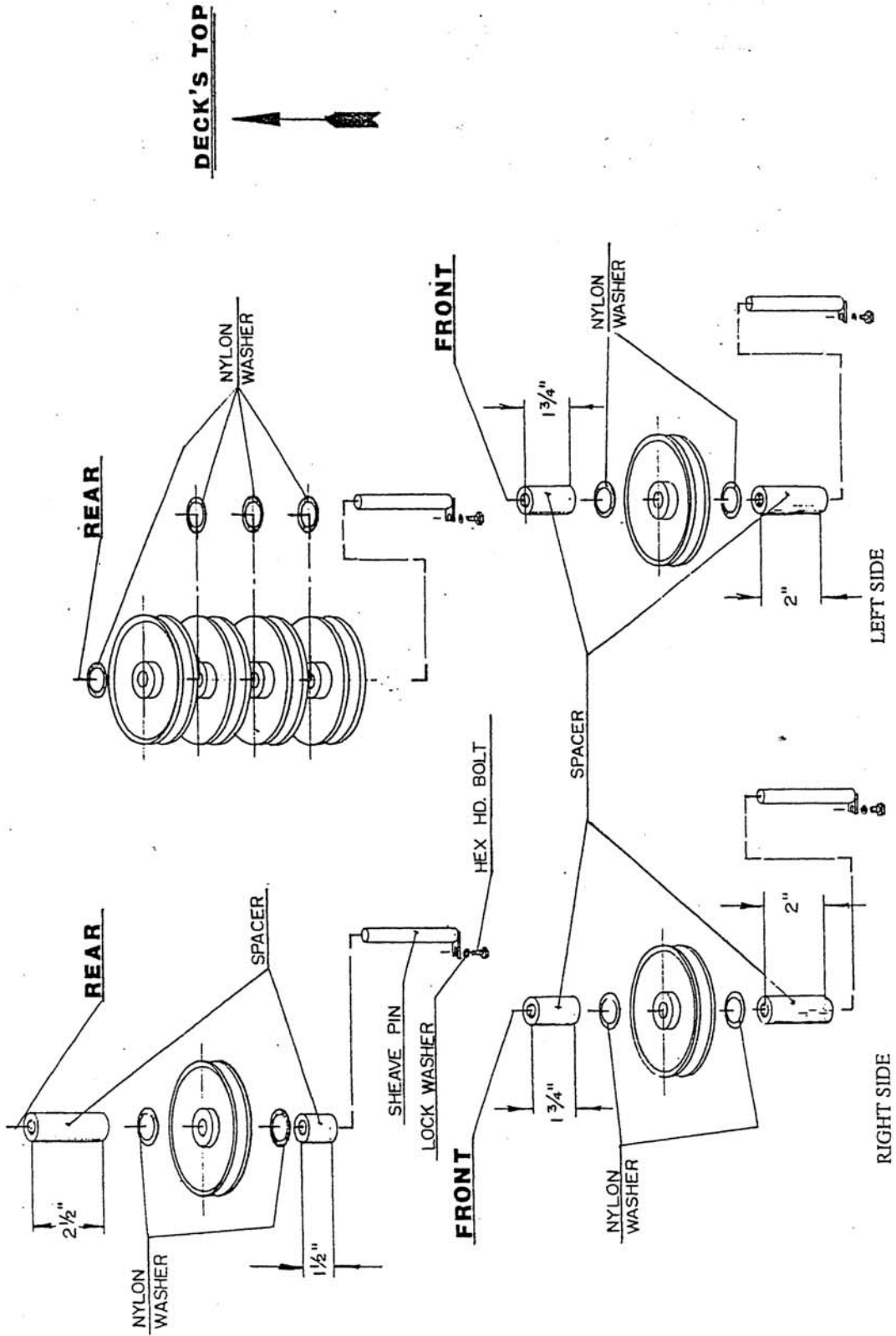

Figure 5

7.4 CABLE INSTALLATION

- Locate cables and set out on the floor. Check the part numbers located on each stud of each cable.

CABLE #1.....PART #2-0643 (318"LG. - L.F.)
CABLE #2.....PART #2-0644 (151"LG. - L.R.)
CABLE #3.....PART #2-0645 (203"LG. - R.R.)
CABLE #4.....PART #2-0646 (367"LG. - R.F.)

NOTE: THE PULLEYS (SHEAVES) ON THE CROSSMEMBERS DO NOT HAVE TO BE REMOVED FOR CABLE INSTALLATION. A 3/8" - 16 UNC × 2 3/4" LG. HEX HEAD BOLT MUST BE REMOVED FROM THE CROSSMEMBERS TO ALLOW CABLE INSTALLATION AROUND THE PULLEYS. THIS 3/8" - 16 UNC × 2 3/4" LG. HEX HEAD BOLT MUST BE REINSTALLED AFTER THE CABLES ARE ROUTED THROUGH THE CROSSMEMBER ASSEMBLIES.

WARNING!!!

DO NOT APPLY LUBRICANT TO SHEAVE ASSEMBLY. FIBRE BUSHING IS PTFE SELF-LUBRICATING. THE ADDITION OF LUBRICANT WILL SHORTEN THE LIFE OF THE FIBRE BUSHING.

- Before beginning cable routing, refer to Figure 4 Cable and Routing Diagram.
- Begin routing cable #4 (part #2-0646) from the right side of the front crossmember assembly using the non threaded end of the cable as described in Figure 4, and out through the opening under the front of the right deck.
- CHECK FOR CORRECT ARRANGEMENT OF SPACERS ON SHEAVE STACKS, FIGURE 5.
- Install the sheave into the front of the right deck as shown in Figure 5.

NOTE: MAKE CERTAIN THAT THE CABLE RUNS BETWEEN THE WELDED GUIDE PIN AND THE GROOVE IN THE PULLEY.

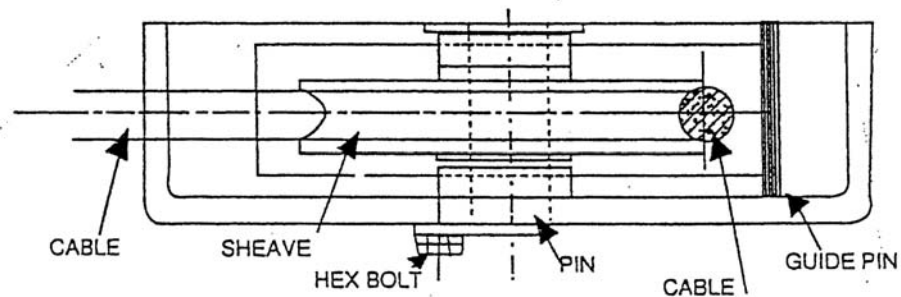

SHEAVE STACK

Figure 6

NOTE: Typical deck sheave arrangement. Left and right front deck shown; cable must run between the welded guide pin and the groove in the sheave. Left and right front spacers have equal top and bottom sizes.

NOTE: Similar arrangement for sheave stack. Right deck rear spacer sizes are not equal - larger goes on top of stack.

- Continue to pull cable #4 over the center support of the right deck.
- Begin routing cable #3 (Part # 2-0645) from the right rear crossmember assembly using the non threaded end of the cable as described in figure 4, and out through the crossmember assembly to the opening under the rear of the right deck.

TIP: TAPE THE TWO CABLES TOGETHER, CABLE #3 ON TOP OF CABLE #4. THIS WILL KEEP THE TWO CABLES FROM TWISTING IN THE REAR CROSSMEMBER ASSEMBLIES.

- Continue to feed cables #3 and #4 through the rear crossmember assembly and out of the opening under the rear of the left deck.
- Install the sheave into the rear of the right deck as shown in figure 5.
- Route cable #2 (Part # 2-0644) from the left side of the rear crossmember assembly using the non threaded end of the cable as described in figure 4, and out through the crossmember assembly to the opening under the rear of the left deck.
- Route cable #1 (Part # 2-0643) from the left side of the front crossmember assembly using the non threaded end of the cable as described in figure 4, and out through the crossmember assembly to the opening under the front of the left deck.
- Install the sheave into the front of the left deck as shown in figure 5.

NOTE: MAKE CERTAIN THAT ALL CABLES ARE IN THE RIGHT POSITIONS AND ARE NOT TWISTED. VERIFY THAT ALL FOUR (4) OF THE 3/8"-16 UNC × 2 3/4" LG. HEX HEAD BOLTS ARE REINSTALLED ON THE CROSSMEMBER ASSEMBLIES.

- Install the sheave stack assembly at the rear of the left deck as shown in figure 5, Sheave Installation.

NOTE: ALL POSTS HAVE THE SAFETY RACKS ALREADY INSTALLED. THE LEFT FRONT POST WILL HAVE A MOUNTING BRACKET FOR THE POWER PACK INSTALLATION.

- Stand posts into position according to Figure 1 and 2.
- Install the threaded stud end of the cables through the top of the post. Use a 7/8" flat washer, and two (2) 7/8"-14 UNF hex nuts with cable spacers as required, to compensate for uneven floors.

7.5 POWER PACK INSTALLATION

- Bolt the power pack to the mounting bracket on the front face of the left front post using four (4) 5/16"-18UNC x 1"LG. hex head bolts and four 5/16" lockwashers. Refer to Figure 7.

NOTE: WHEN WORKING WITH HYDRAULIC LINES AND VALVES, IT IS IMPORTANT TO KEEP ALL COMPONENTS CLEAN AND FREE OF DIRT.

POWER PACK DETAILS

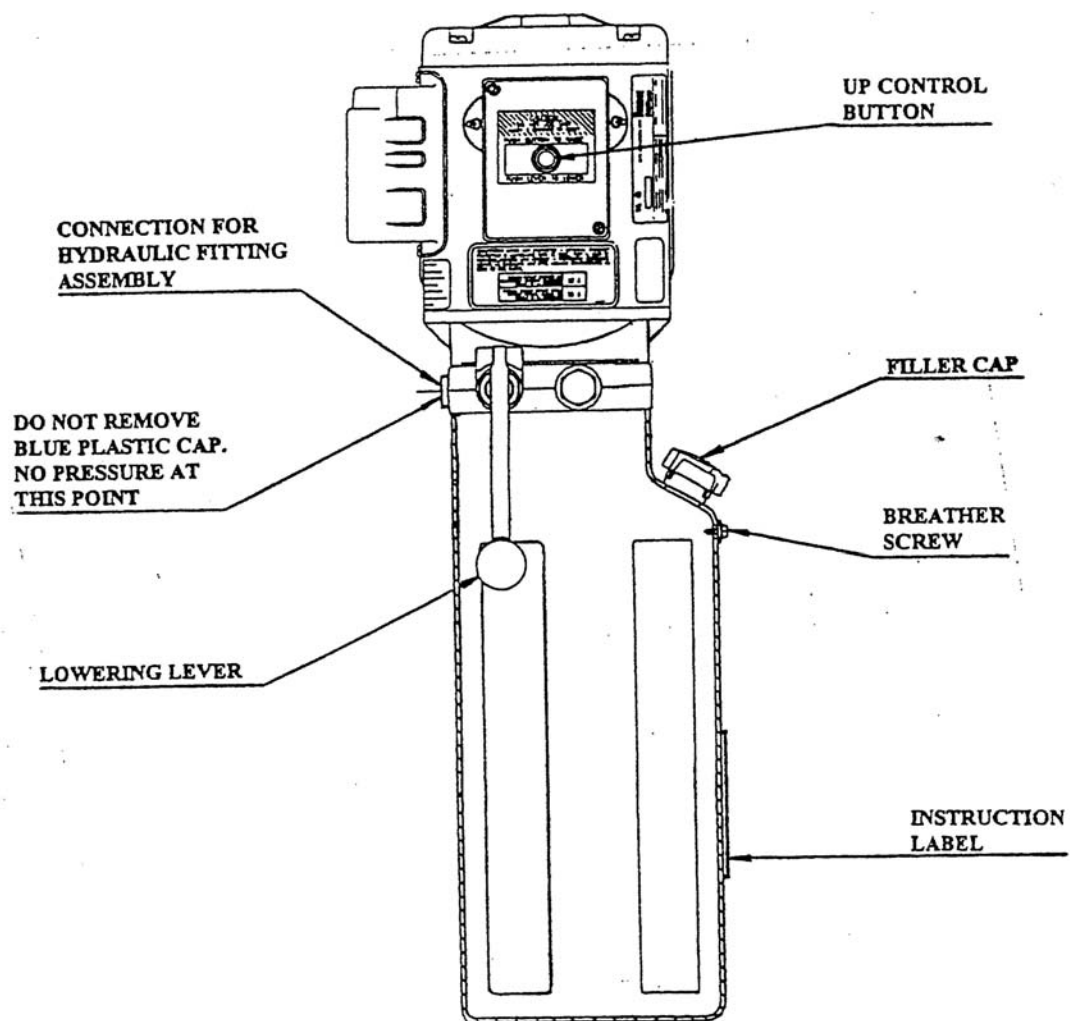

Figure 7

7.6 ELECTRICAL CONNECTIONS

CAUTION: ALL ELECTRICAL CONNECTIONS SHOULD BE MADE BY A QUALIFIED ELECTRICIAN.

Please refer to Figure 8, Electrical Diagram for 230 volts/1 phase electrical connections.
Electrical Breaker Size Recommendation: 20Amps

Electrical Diagram for 208-230V/1Ph/60Hz

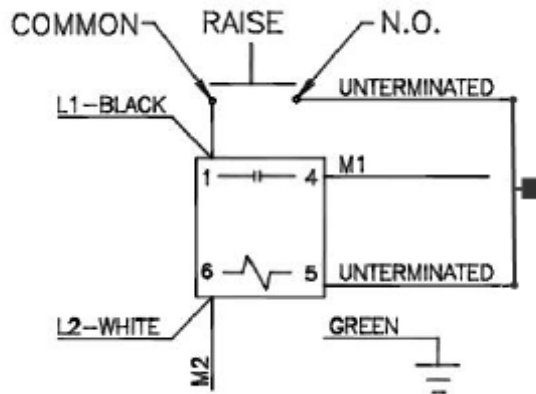

Figure 8

7.7 HYDRAULIC INSTALLATION

- Refer to Parts Manual, Hydraulic and Air Kit Diagram

TIP: TAPE ONE END OF THE HYDRAULIC HOSE TO THE TWO POLYTUBES AND FEED THEM THROUGH THE BLACK PLASTIC PIPING. THEN REMOVE THE TAPE.

- Connect 3/8" JIC, M end of the flexible hydraulic hose to the fitting at the cylinder.

DO NOT OVER TIGHTEN.

- Install flow control assembly.
- Attach the other end 3/8" JIC, F of the flexible hydraulic hose to the adapter fitting on the power pack (3/8" JIC, M).

NOTE: THE HYDRAULIC CYLINDER IS NOT EMPTY

NOTE: THE PLASTIC PLUG ON THE POWER PACK IS NOT USED. THERE IS NO HYDRAULIC PRESSURE.

NOTE: THE CYLINDER ROD MUST BE EXTENDED IN ORDER TO INSTALL THE NON-THREADED END OF THE CABLES TO THE CABLE FLANGE ON THE ROD.

- Remove the hydraulic cap from the fitting at the base of the hydraulic cylinder.
- Use an air chuck and blow air into the fitting in the breather hole in the base of the cylinder to extend the rod.

NOTE: AS ROD EXTENDS, OIL FROM CYLINDER RETURNS TO POWER PACK. RELEASE HANDLE ON POWER PACK NEEDS TO BE HELD DOWN (OPEN) TO ALLOW OIL TO RETURN TO POWER PACK.

- Continue to extend the rod until the non-threaded end of the cables are reached.
- Remove the clamp from the cable flange.
- Install the cables as shown in Figure 4, Cable and Routing Diagram.
- Reinstall the clamp to the cable flange.

HYDRAULIC AND AIR KITS INSTALLATIONS

- Locate the supply lines: 1/4" and 3/8" polytube, 3/8" flexible hydraulic line, and the black plastic piping.
- Install the black plastic piping to the steel pipe welded to the underside of the front left side crossmember assembly.

7.8 AIR INSTALLATIONS

- Attach the air valve assembly using two (2) #8 - 32 UNC × 1"lg. Phil. HD. screws to the two (2) #8 - 32 UNC hex nuts on the outside face of the left front post.

NOTE: MOST OF THE 1/4" AND 3/8" POLYTUBE CONNECTIONS HAVE BEEN MADE IN THE CROSSMEMBERS ASSEMBLIES AND LEFT DECK. ONLY FINAL CONNECTIONS ARE REQUIRED TO BE MADE. THE 1/4" POLYTUBE WILL BE USED FOR THE AIR CYLINDER LOCKS AND THE 3/8" POLYTUBE WILL BE USED FOR THE AIR OUTLETS TO THE JACKING BEAMS.

CAUTION: DO NOT OVER TIGHTEN CONNECTORS.

- Connect all of the 1/4" polytubes, which have been previously installed, coming out of the black plastic piping at the left front crossmember assembly, to the cross and tee pushlock fittings at the front and rear of the left deck. See Hydraulic & Air diagram (Page 27).
- Connect the opposite end of the 1/4" polytube, coming out of the black plastic piping, to the air valve on the outside face of the left front post.
- Connect the 3/8" polytube, coming out of the black plastic piping at the left front crossmember assembly, to the 3/8" polytube fitting at the front inside under the left deck.
- Connect the opposite end of the 3/8" polytube, coming out of the black plastic piping, to the air valve outlet on the outside face of the left post.

NOTE: FOR THOSE UNITS EQUIPPED WITH JACKING BEAMS, THIS WOULD BE THE TIME TO INSTALL THEM. CONSULT THE JACKING BEAM INSTRUCTIONS MANUAL FOUND IN EACH JACK BEAM BOX.

- IF JACK BEAMS ARE INSTALLED, PLUG THE ONE REMAINING OUTLET AT THE FRONT AND REAR OF THE LIFT.
- IF JACK BEAMS ARE NOT INSTALLED, USE PLUGS AND/OR COUPLERS TO PLUG AIR OUTLETS.

- Hook up an air supply to the inlet of the water trap on the air valve assembly located on the outside of the left post.
- Check for air leaks.
- Check the operation of the air cylinder locks by depressing the air valve on the outside of the left front post.
- Press the “UP” button on the hydraulic ALL power pack. Continue raising until the lift is supported by the cables.

NOTE: MAKE CERTAIN THAT THE MECHANICAL SAFETY LOCKS AND CABLE ROLLERS ARE WORKING PROPERLY.

4.9 SAFETY RETAINING SYSTEM

- Assemble the safety retainer bracket assemblies using the supplied hardware as shown in Section 10.
- Install one 5/16”x 3/4” long hex head bolt with one 5/16” lock washer and one 5/16” flat washer into the top mounting hole location on the crossmember but do not tighten. Leave at least 3/16” space between the lock washer and the crossmember.
- Insert the bracket assembly inside the post and slide up into place between the post and the crossmember so that the bolt and washers slide into the upper slot.
- Install the second 5/16”x 3/4” long hex head bolt and 5/16” lock washer and flat washer through the lower slot and into the bottom mounting hole in the crossmember. Tighten both of the bolts. See Figure 9.
- Repeat for all sides of crossmembers.

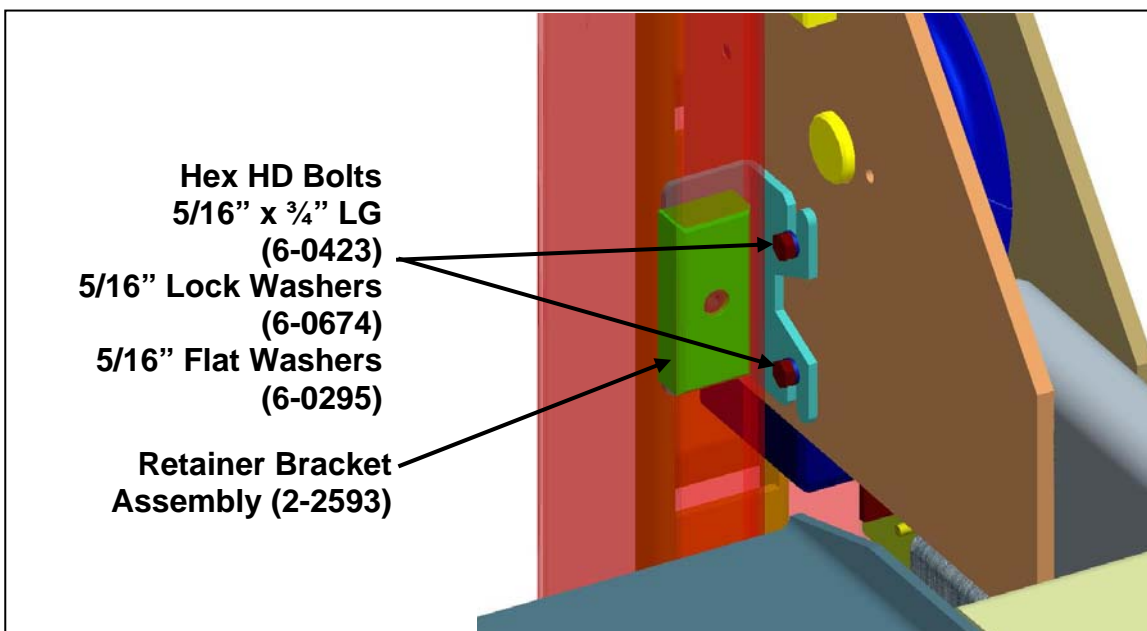

Figure 9. Retainer bracket installation

7.9 LEVELING PROCEDURE

7.9.1 LEVELING LIFT TO FLOOR

- Lower the lift completely to the floor.
- Determine the highest corner of the lift and adjust remaining towers to level the lift, front-to-back and side-to-side (See positions 1, 2, 3 and 4 in **Fig. 11**). Use shims under tower base plate, as needed.

7.9.2 DECK LEVELING PROCEDURE

NOTE: Use a four (4) foot level to adjust the cables to level the decks side-to-side and front-to-rear. All cable adjustments can be made at the threaded end of the cable at the top of each of the four (4) posts.

- Tighten the two (2) 7/8" - 14 UNF hex nuts on each cable at the top of each post.
- Raise the lift to check operation.
- Lower lift by depressing the air valve while pulling down on the release lever of the power pack.
- Remove hand from air valve and allow the lift to hang on the cables.
- Use a four (4) foot level. Level and square all four posts.
- Begin leveling the highest post.

POST LEVELING

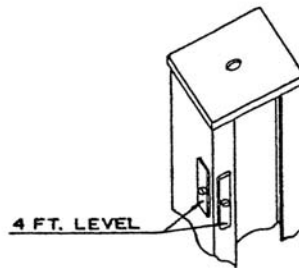

Figure 10

NOTE: MAKE CERTAIN THAT THE SAFETY RACK IN EACH OF THE POSTS IS SQUARE TO THE CROSSMEMBER ASSEMBLY AND THAT A MINIMUM CLEARANCE OF 1/8" IS MAINTAINED BETWEEN THE INSIDE FACE OF THE POSTS AND THE PLASTIC GUIDES ON THE CROSSMEMBER ASSEMBLY.

CAUTION: USE THE CORRECT WEDGE ANCHOR BOLTS. (SUPPLIED)

DECK LEVELING

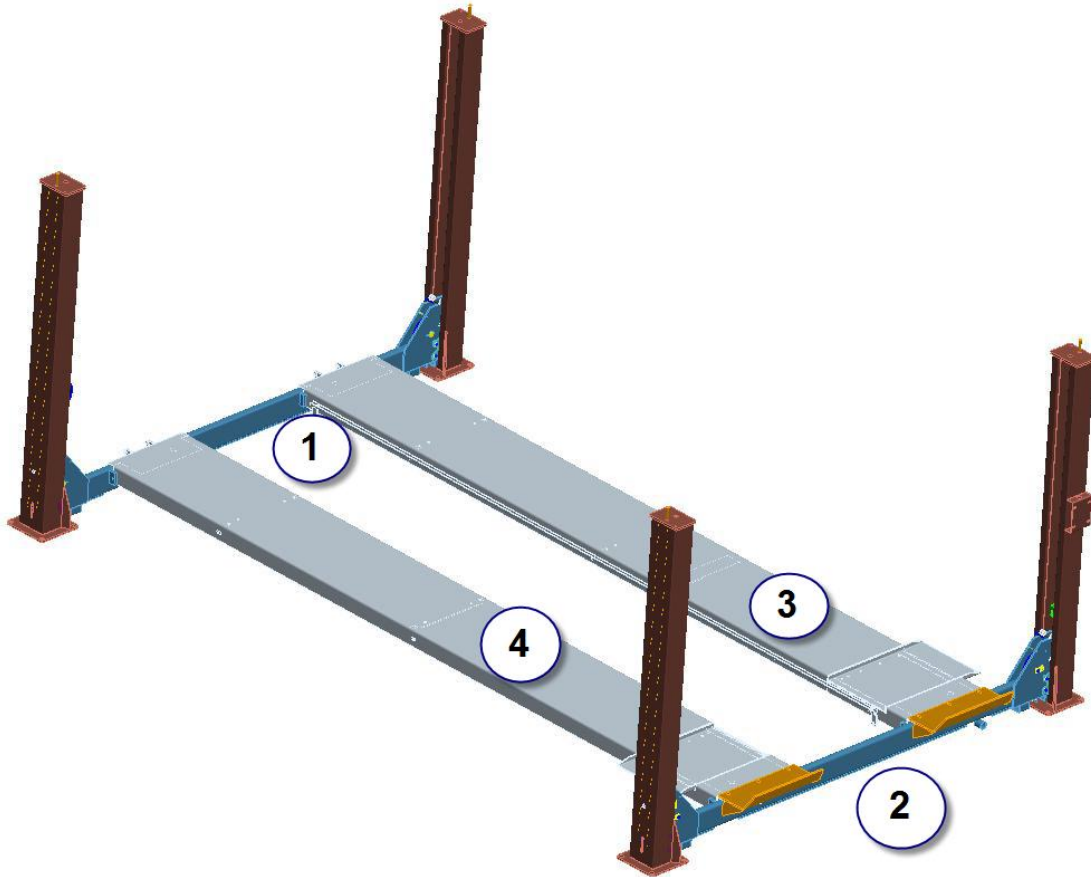

Figure 11
(Lift may not be as shown)

NOTE: Check and adjust the decks for level using the 4' level. Both the front plate cut-outs and rear steer plates should be checked.

7.9.3 LEVELING PROCEDURE - SAFETY LADDERS

1. After the lift has been leveled on the cables, adjust the safety racks.
2. To check the mechanical safety locks, raise the lift up; make sure all locks engage at the same time making one noise. If the safeties are off slightly, gently bump the up button until you hear the first safety lock engage. Determine at which post the safety engaged; adjust each of the other safety racks until you hear the safety engage. Recheck to make certain that the safeties are engaging together.
3. To do this loosen the $3/8'' - 16 \text{ UNC} \times 1''$ lg. hex bolt at the bottom back of each post and pull safety racks up until they come into full contact with each of the safety shoes on the crossmember assembly.

4. When level, tighten the two (2) 5/8" - 11 UNC hex nuts at the top of each safety rack and the 3/8" - 16 UNC × 1" lg. hex bolts at the bottom back of each post.
5. Raise the lift to check for full operating height of 71". This measurement is taken from the top of the decks to the floor.

7.10 APPROACH RAMPS, WHEELSTOPS, PULLEY COVERS

1. Install approach ramps using ramp pins and cotter pins provided. Ensure the proper operation of the ramps.
2. Install front wheel stops using six (6) 1/2" - 13 UNC × 1" lg. hex bolts and 1/2" lockwashers.
3. Install the four (4) sheave covers over the sheaves in the crossmember assembly.
4. Cycle the lift several times to check proper operation of the cables, safety lock, air locks, etc...

STOP IMMEDIATELY IF THE LIFT IS NOT OPERATING PROPERLY. Adjust and recheck for proper operation.

7.11 ANCHOR INSTALLATION

- The 1/2" × 4 1/2" lg. wedge anchor bolts supplied allow for the thickness of the base plates plus a maximum of 3/4" of shim stock. **DO NOT USE ANCHORS SUPPLIED IF MORE THAN 3/4" INCH OF SHIM STOCK IS USED.**
- Recheck all measurements before anchoring posts.

Note: First anchor the power post, and then work clockwise.

- Using a 1/2" concrete drill bit and rotary hammer drill, drill through the concrete floor in the four (4) anchor bolt location holes positioned on the base of each post.

ANCHOR INSTALLATION

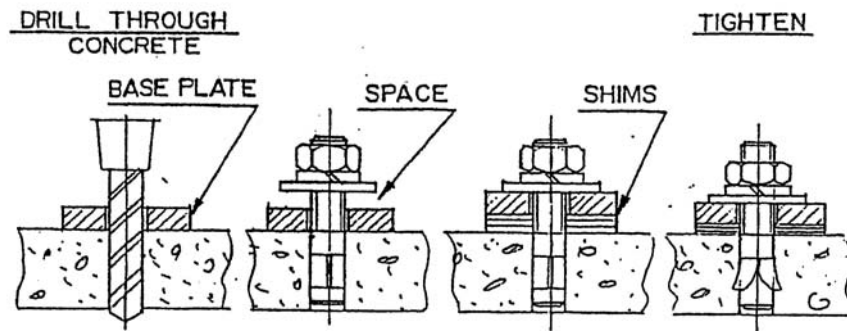

- Tighten all anchor bolts to a torque of 55 ft. lbs.
- Recheck and adjust the level of post(s) and cable(s) if necessary.

NOTE: IN CASES WHERE THE FLOOR IS EXTREMELY OUT OF LEVEL, THE MECHANICAL SAFETIES MAY NOT ENGAGE ON THE SAME LOCK.

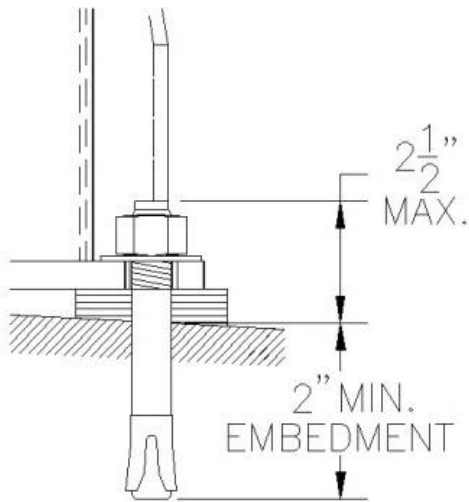

NOTE: THE 1/2" × 4 1/2" LG. WEDGE ANCHOR BOLTS SUPPLIED MUST HAVE A MINIMUM EMBEDMENT OF 2" INTO CONCRETE FLOOR.

NOTE: IN CASES WHERE THE FLOOR IS EXTREMELY OUT OF LEVEL, THE MECHANICAL SAFETIES MAY NOT ENGAGE ON THE SAME LOCK.

7.12 SAFETY AND OPERATING INSTRUCTIONS

1. **Inspect** your lift daily. Do not operate it if malfunctions occur or damaged parts have been found.
2. **Never** attempt to overload the lift. The manufacturer's rated capacity is shown on the serial number tag on the power post.
3. **Operating controls, DO NOT OVERRIDE** the safeties. The mechanical safeties are designed to engage automatically on the way up. Press the up switch of the power pack to go up. When the desired height is reached, lower onto the safety. To lower, raise off of the safety locks, then press the air release valve and the lowering release lever at the same time.
4. **Only trained** and authorized personnel should operate the lift. Do **not** allow customers or bystanders to operate the lift or be in the lift area.
5. **Caution**, never work under the lift unless the mechanical safety locks are engaged.
6. **Before** driving vehicle on, make sure lift is in the fully down position.
7. **Before** removing the vehicle from the lift, make sure the lift is in the fully down position and ensure that all tools have been removed from the deck surfaces.
8. **Always** keep the lift area free from debris. Grease and oil spills should always be cleaned up immediately. **Never** leave any tools or parts lying on the decks.
9. **Never** operate lift with passengers in vehicle.

NOTE: DO NOT ATTEMPT TO OPERATE THIS LIFT IF ANY PART IS NOT WORKING PROPERLY OR YOU HAVE NOT READ THE COMPLETE OPERATING INSTRUCTION MANUAL.

7.13 FINAL CHECK OF ASSEMBLED LIFT

1. Final dimension check after anchoring. _____
2. Check for air and hydraulic leaks. _____
3. Ensure cables are properly routed and free from obstructions. _____
4. Ensure all safety lock mechanism are working correctly. _____
5. Re-check level of post and decks. _____
6. Makes sure ramps are secured correctly with cotter pins and washers. _____
7. Check all fasteners, tighten if necessary. _____
8. Check direction of flow control (arrow pointed toward power unit). _____
9. If jack beams are supplied, ensure keeper bracket are installed. _____
10. Check jam nuts on cables and safety ladders are tightened. _____
11. Ensure cable flange clamp is installed correctly and tighten. _____
12. Ensure cylinder shaft Jam Nuts are installed as per instructions. _____
13. Ensure wheelstops are installed. _____
14. Ensure wheel chocks are provided. _____
15. Operate lift to full stroke then lower to ground while checking for proper functionality. _____
16. Ensure Customer Care Kit is complete and given to operator. _____
 - a. Operation Manual _____
 - b. ANSI / ALI Lift It Right Manual _____
 - c. ANSI / ALI Safety Tip Card _____
 - d. ANSI / ALI ALIS Safety Requirements for Installation and Service of Automotive Lifts _____
 - e. ANSI / ALI Quick Reference Guide _____
17. Train end user on operation of the lift. _____

7.14 OPERATION TEST WITH VEHICLE

1. Lower lift to ground.
2. Drive vehicle on to lift, install wheel chocks (Front & Back).
3. Raise lift to and lower onto 3-4 lock positions during full rise to ensure all locks are working correctly.
4. Double check level of runways, front to rear and side to side while on locks.
5. Re-adjust cables if necessary while vehicle is on.
6. Check lowering speed and smooth decent rate.
7. Lower lift to ground, remove wheel chocks and drive vehicle off lift.

If any problems occur during the final checkout or operation of the lift please contact customer service at 1-800-268-7959

8.0 RECOMMENDED INSPECTION AND MAINTENANCE

8.1 LUBRICATION SPECS

Where hydraulic oil is required	> ISO 32 10W - non detergent hydraulic oil
Where grease is required	> multi-purpose lithium grease
Where multipurpose lube is required	> multi-purpose SAE 30 lubricating oil
Where pneumatic oil is required	> Snap-On air motor oil IM1PT
Where cable lube is required	> 2001 MONOLEC [®] wire rope lubricant or equivalent

WARNING

If you are not completely familiar with automotive lift maintenance procedures, STOP. Contact Snap-on Equipment Technical Support for instructions. To avoid personal injury, permit only qualified lift service personnel to perform maintenance on this equipment.

Always raise lift when cleaning floor area with solvents and/or cleaning compounds.

Always replace cable break safety springs when replacing cables.

Please refer to the following table for specific inspection and maintenance frequency.

COMPONENT	INSPECTION FREQUENCY						
	DAILY	WEEKLY	MONTHLY	QUARTERLY	SEMI-ANNUALY	ANNUALY	
Entire Lift and surrounding area	8.15					As shown before, and ALL Standard	
Entire Lift Operation	8.15						
Fasteners		8.3					
Wire Ropes		8.2.3	8.2.4	8.2.5			
Sheaves		8.4.1		8.4.2			
Sheave Pins		8.4.3		8.4.2			
Safety Dogs	8.5		8.3				
Slack Cable Devices	8.6						
Latch Plates (Ladders)			8.6				
Air Filter, Regulator, Lubricator	8.7						
Approach Ramps, Chocks, Wheel Stops	8.12						
Anchor Bolts			8.11.2				
Turn Tables and Rear Slip Plates	8.13.1		8.13.2	8.13.3	8.13.5		
Bearing Cage / Rear Slip Plates	8.13.1		8.13.2	8.13.4	8.13.5		
Edges of Cable Flange Slots	8.2.6						
Runways			8.10.1				
Columns			8.11.1				
Air cylinders, Lines, Fittings			8.7				
Hydraulic Power Pack, Hose, Fittings			8.8				8.8
Hydraulic Cylinder				8.9			
Jack Beam Rails, Oil Drain Pan				8.10.2			
Anti-skid Surfaces				8.13.5			
Rolling Air Jacks			8.14				

8.2 WIRE ROPES

⚠ WARNING

- Wire ropes are critical to safe and reliable performance of your lift.
- Cables are expendable items and should be replaced as a set.

8.2.1 WIRE ROPE CONDITIONS GUIDE

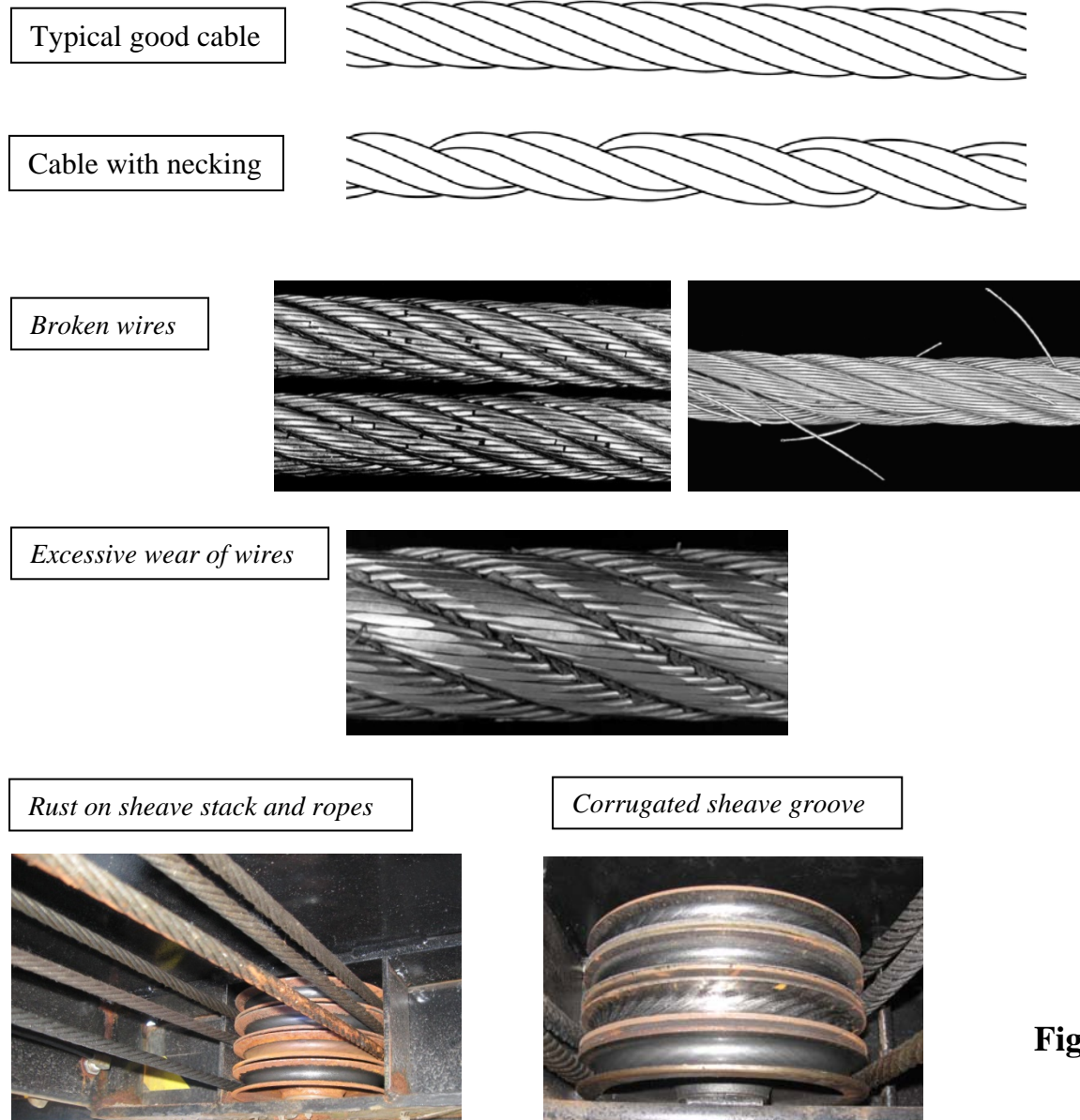

Figure 15

8.2.2 WIRE ROPE REPLACEMENT CRITERIA:

⚠ WARNING

If any cable is found to be in need of replacement, the entire cable set, pulleys and safety rollers must be replaced immediately.

See 8.2.1, cable conditions guide.

In the following table, "lay" means the distance measured along a line parallel to the axis of the rope in which the strand makes one complete turn about the axis of the rope, or the wires make a complete turn about the axis of the strand.

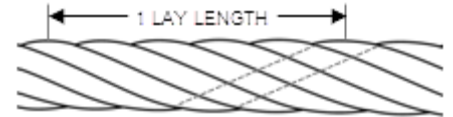

<i>The wire rope must be removed from service if one or more of the following criteria are met:</i>
1. More than six randomly distributed broken wires in one rope lay or $6 \times d$ length.
2. More than three broken wires in one strand in one rope lay or $6 \times d$ length.
3. Three or more broken wires at rope terminations.
4. One outer wire broken at the point of contact with the core of the rope which has worked its way out of the rope structure and protrudes or loops out from the rope structure
5. Heavy rusting, corrosion, or pitting. A light surface corrosion on outer wires is normal.
6. Wear or scraping of one-third of the original diameter of outside individual wires
7. Excessive stretch. It is normal for new cable to require adjustment during "break-in", after which small periodic adjustments may be required. However, if a cable that has been in service for 6 months should suddenly require frequent adjustments or has used all the cable adjustment available, all cables must be replaced immediately.
8. Deformed strands, kinking, crushing, birdcaging, or any other damage in distortion of wire rope structure
9. Variations in diameter (necking) or any change from normal appearance
10. Reductions from nominal diameter of more than $1/32$ " (for cables $3/8$ " to $1/2$ " dia. inclusive)
11. End attachments cracked, deformed or worn

8.2.3 WIRE ROPE INSPECTION

Inspect wire rope cables for wear or damage. Wipe cables with a rag to detect hard to see small broken or frayed cable strands. See chapter 8.2, Fig.15 and ANSI/ALI ALOIM standard.

8.2.4 WIRE ROPE LUBRICATION

Lubricate wire ropes with lift in both lowered and raised position, by spraying them with wire rope lubricant (i.e. 2001 MONOLEC®) and wiping the cable down.

8.2.5 WIRE ROPE ADJUSTMENT

Adjust cables if lifting is uneven or lift is not level (See chapter 6.10.3). Never make adjustments with weight on lift. If running out of adjustment threads, cables need to be replaced. Do not add washers or other spacers to re-use previously used adjustment threads.

Wire rope tension adjustment should be performed when installing the lift and every three months.

8.2.6 INSPECT CABLE FLANGE

Make sure the edges of the counter-bores in the cable flange are not damaged or worn, indicating that cable sleeves may not be properly seated at all times.



8.3 FASTENERS

Check all the attaching bolts and nuts for tightness.

Note: Air cylinder bolts and nuts should allow movement of the cylinder.

8.4 SHEAVES AND PINS

Sheaves and pins are expendable items. Sheaves and pins should be replaced when worn. Use of sheaves and pins with excessive wear will lead to reduced service life of the cables.

⚠ WARNING

Bushings inside sheaves work best in “dry” condition. Applying oil will diminish their performance and greases will degrade performance even further. DO NOT GREASE SHEAVE BUSHINGS OR SHAFTS.

8.4.1 VISUAL INSPECTION OF SHEAVES

- Check sheaves and replace if cracks or other damage are found.
- Visually inspect alignment of sheaves. Misalignment of sheaves indicates excessive wear. Remove, inspect, and, if needed replace sheave and pin.

8.4.2 MEASURE SHEAVE WEAR

- Inspect sheaves in cross-members with lift in lowered position and resting on safety latches
- Place safety stands under front and rear cross-members. Stop lift on mechanical safety locks. One person should hold the lowering handle on power unit down while another person pulls on cables in each column to create slack in cables.
- Check for ease of rotation. If sheaves do not turn freely, the sheave and sheave pin should be removed, inspected, fixed or replaced.
- Fully raise the lift, to inspect sheaves in runways. Hold lowering handle down to lower lift onto safety latches
- Pull on cables in runway to create slack in cables.
- Check all sheaves for excessive wobble, or movement. Grasp rim of sheave and attempt to wobble (tilt) side to side. If sheaves wobble (tilt) more than 3/16” (1.6 mm) side to

side, or move in and out more than 1/32 (0.8 mm), the sheave and sheave pin (shaft) should be replaced. Replace immediately if needed.

8.4.3 SHEAVE PINS

Sheave pins are held in place by a Hex Head Bolt, washer and lock washer. Check for loose sheave pins, loose or missing fasteners to hold sheave pins in place. Remediate situation immediately.

8.5 MECHANICAL SAFETY LATCHES (DOGS)

Watch and listen to safety latch operation during lift operation, to ensure that latches move as required, have not lost spring preload, and line up with slots in latch plates (safety ladders) in columns. Watch for broken traction springs on safety latches.

Check and adjust safety ladders if lift is not level on safety, or if safeties do not engage properly. Stop using the lift if any malfunction or damage is observed.

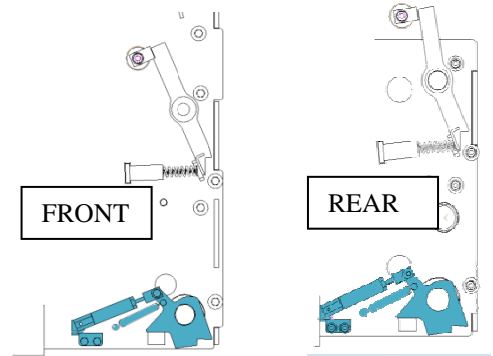

Mechanism may not be as shown.

8.6 CABLE BREAK SAFETY MECHANISM

With lift not loaded, all four cable break levers should produce deflection of the lift cables.

Inspect slack cable device as follows:

Check for missing or damaged parts. Watch for broken springs.

Check if the spring is properly seated in the support tube and in the holder on the cable break safety lever. Watch cable tracking properly on cable break safety roller. Check if the safety roller and bolt are properly attached to the cable break safety lever. Verify that the cable break safety lever is centered within the cross-member, and that it lines up with the openings in the safety ladder. Verify using hand force or a light lever that the cable break safety lever pivots on the shaft.

Lubricate with light lubricant if required.

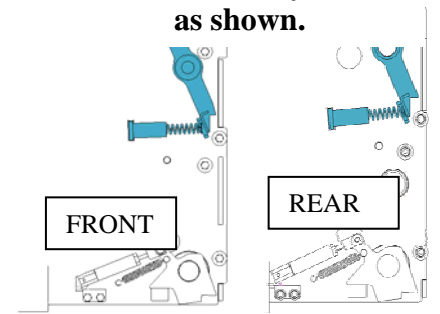

Mechanism may not be as shown.

8.7 AIR CYLINDERS, AIR LINES, VALVE AND FITTINGS

Check filter/regulator/lubricator in supply line to lift. (customer supplied, typically at compressor). Drain water trap filter bowl and adjust oil feed according to manufacturer's instructions.

Drain water bowl on lift supplied water separator. Press valve at the bottom of the bowl to clear.

Check operation of air release valve for air leaks.

Check air cylinders for visible damage.

Check air lines for leaks, wear or kinks.

8.8 HYDRAULIC POWER PACK AND HOSE

Check all air and hydraulic hoses, fittings and cylinders for leaks.

Check level of oil in power pack reservoir when lift is in the lowered position. Add if required.

Check fluid level of lift power unit and refill if needed. If refill was needed, inspect all fittings, hoses and seals. Tighten, repair or replace as required.
Change hydraulic fluid every 2 years.

8.9 HYDRAULIC CYLINDER

Inspect the hydraulic cylinder mounting to the runway. Inspect cylinder and hydraulic hose for leaks. Repair or replace as required.

Check and tighten the hydraulic cylinder rod nuts holding the cable flange.

Inspect bolts holding anti-rotation bar onto cable flange and tighten if required. (If applicable)

Inspect sliders on anti-rotation bar for excessive wear or damage. Replace if required. (If applicable)

WARNING

Failure to do so will lead to reduced service life, which could result in property damage and/or personal injury.

8.10 RUNWAYS

8.10.1 CHECK RUNWAYS

Check level of runways on the floor, on the locks and on the cables: Refer to **Section 6.10**.

Adjust as required.

Check runways for damage or abnormal deformation. If such conditions exist, contact Snap-on Equipment Technical Support.

8.10.2 INSPECT JACK BEAM TRACKS

Inspect rolling jack / oil drain pan tracks for cleanliness, corrosion, excessive wear or damage. Clean dirty tracks. Worn or damaged tracks should be repaired immediately.

8.11 COLUMNS

8.11.1 CHECK COLUMNS

Check columns for corrosion, giving special attention to the area at the base of the column. Check severely corroded areas by pecking with an awl or welder's chipping hammer. If column is corroded through at any point, it must be replaced immediately. If not corroded through, remove old paint and rust scale, then coat with a high quality corrosion resistant paint. Clean and lubricate glide blocks.

8.11.2 CHECK COLUMN ANCHORS

Check column anchor bolts for tightness (if loose, re-torque to 55 ft-lb). If anchors do not tighten to required torque, or continue to loosen, contact Snap-on Equipment Technical Support.

Verify proper embedment of anchors after tightening.

NOTE: The $1/2'' \times 4 \frac{1}{2}''$ lg. wedge anchor bolts supplied must have a minimum embedment of 2'' into concrete floor.

NOTE: If anchors do not tighten to required torque, OR project more than $1 \frac{1}{2}''$ above the concrete surface due to floor slope, contact a foundation engineer to determine the best course of

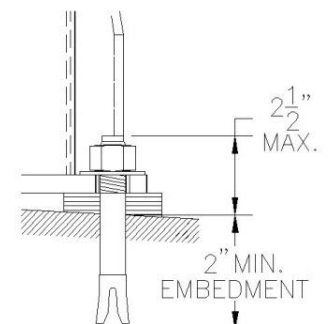

8.12 APPROACH RAMPS, CHOCKS, FRONT WHEEL STOPS

Inspect for excessive wear or damage. Repair or replace if required.

Inspect hinge pins. Replace if excessively worn. Lubricate if in good condition

8.13 FRONT AND REAR STEER PLATES

8.13.1 VISUAL INSPECTION

Check front turn tables and rear slip plates for unusual deflection, damage, fluid spills. Clean or further inspect if needed.

8.13.2 CLEAN REAR SLIP PLATES AND FRONT TURN TABLES

Clean foreign debris from front turn tables and rear slip plates by blowing out with compressed air.

Check and clean steer plates. Lubricate with oil or light grease.

8.13.3 MAINTENANCE OF REAR STEER PLATES

Inspect the non-skid coating on rear slip plates for wear. All areas found to be worn smooth should be resurfaced with an Anti-Slip abrasive floor tread tape or a heavy duty Anti-Slip Floor Coating.

Remove rear slip plate covers. Clean runway surface and touch up any paint wear with a rust resistant paint. Allow paint to dry thoroughly. Inspect transfer balls for excessive wear, deformations or corrosion. Inspect plastic pads (pucks) for excessive wear or deformation. Replace if needed.

8.13.4 MAINTENANCE OF REAR STEER PLATES - IF EQUIPPED WITH PLASTIC BEARING CAGE.

Remove top Slip Plate covers by first removing the four (4) shoulder bolts on each cover. Remove polyethylene-bearing cages insuring that all the Delrin bearings remain in the cages. Additional Delrin bearings may be purchased if required.

Clean runway surface and touch up any paint wear with a rust resistant paint. Allow paint to dry thoroughly.

To obtain optimum performance, the position of the slip-plate bearing cage should be rotated every quarter to change the wear pattern.

With the first quarter maintenance, flip the bearing cage over to the opposite side.

With the second quarter maintenance, rotate the bearing cage end-to-end.

With the third quarter maintenance, flip bearing cage over to the opposite side.

Fourth quarter maintenance should see the bearing cage rotated back to the original position.

Quarterly maintenance will optimize performance and contribute to longer slip plate life.

8.13.5 ANTI-SKID COATING ON REAR STEER PLATES

Inspect the non-skid coating on rear steer plates for wear. All areas found to be worn smooth should be resurfaced with an Anti-Slip abrasive floor tread tape or a heavy duty Anti-Slip Floor Coating.

8.14 ROLLING AIR JACKS

Lubricate roller bearings and roller guide springs.

Dismantle and clean lift arms.

Clean and lubricate rollers/sliders and hinge points.

Clean and lubricate safety mechanism.

Change hydraulic oil every two years

8.15 ENTIRE LIFT

Wire ropes, columns, runways and other lift parts should be kept free of corrosive agents, solvents, and road salts. If such agents are spilled or splashed on any lift component, immediately rinse thoroughly with water and wipe down with a clean rag. Lubricate again wire rope as shown at **8.2.4**.

Check general operation of lift. Observe any structural noise, imbalance, binding, or other malfunctions.

WARNING

Failure to keep the lift free of corrosive agents and solvents will lead to reduced component service life, cable failure, etc., which could result in property damage and/or personal injury.

9.0 LIFT ASSEMBLY

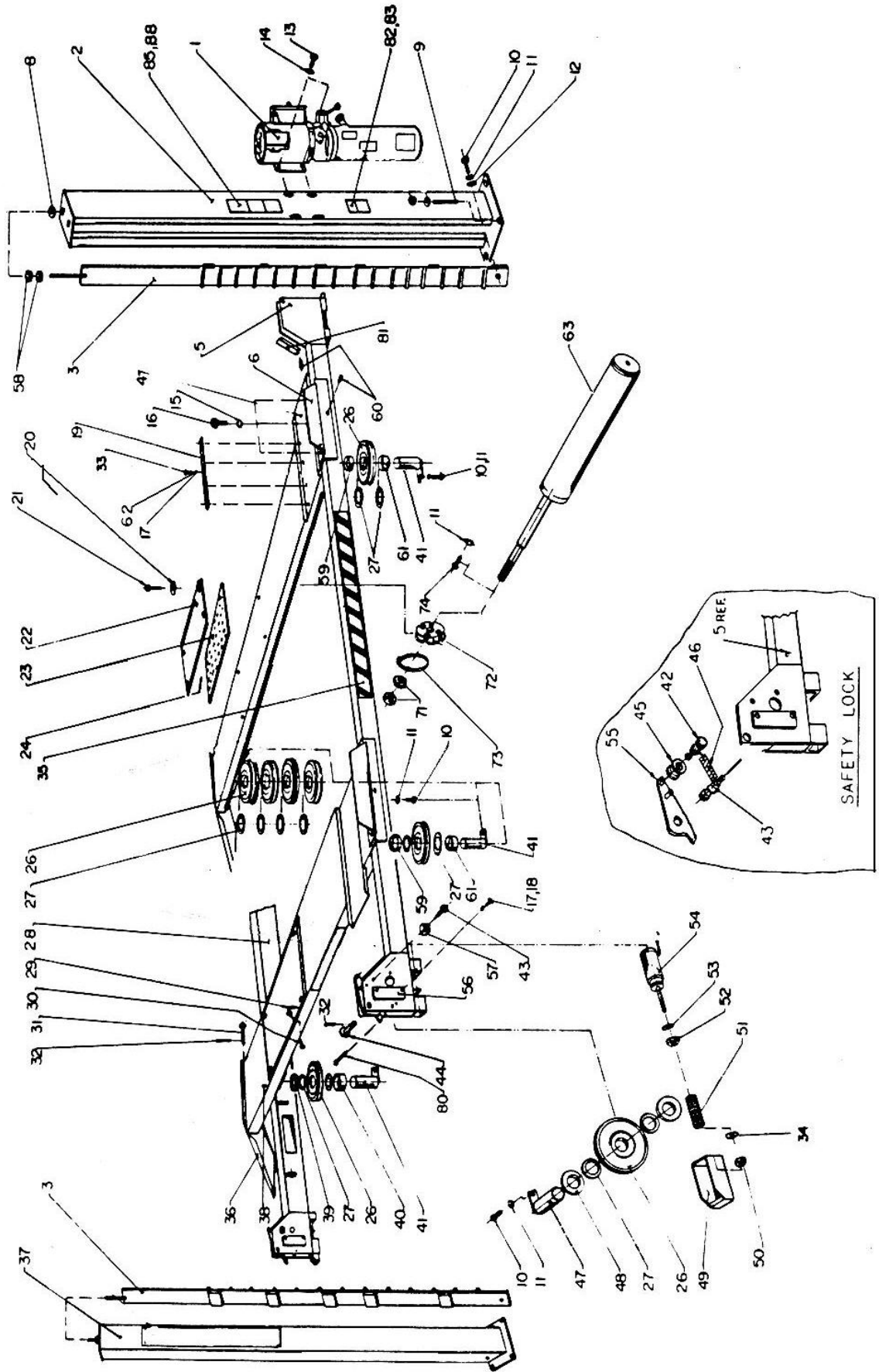

PARTS LIST

ITEM	QTY.	DESCRIPTION	PART#
1	1	POWER PACK, 230V/1PH/60HZ	6-1936
2	1	POWER POST	4-1361
3	4	SAFETY RACK	3-0487
4*	1	ALIGNMENT DECK WLDMT, (LEFT SIDE)	4-0222
5	1	FRONT CROSSMEMBER WELDMENT	4-0190
6	2	FRONT WHEEL STOP	2-0998
8	8	FLAT WASHER, 3/4" I.D.	6-0738
9	16	WEDGE ANCHOR, 1/2" X 4 1/2" LG.	6-0140
10	12	HEX HD. BOLT, 3/8"-16UNC X 1" LG. GR.8	6-0668
11	14	LOCKWASHER, 3/8" I.D.	6-0058
12	8	FLAT WASHER, 3/8" I.D.	6-0625
13	4	HEX HD. BOLT, 5/16"-18UNC X 3/4" LG.	6-0423
14	4	LOCKWASHER, 5/16" I.D.	6-0674
15	6	LOCKWASHER, 1/2" I.D.	6-0059
16	6	HEX HD. BOLT, 1/2"-13UNC X 1" LG.	6-0045
17	32	LOCKWASHER, 1/4" I.D.	6-0056
18	16	HEX HD. BOLT, 1/4"-20UNC X 3/4" LG.	6-0178
19	4	RETAINING BAR	2-1391
20	8	FLAT WASHER, 13/32" I.D. X 2" O.D.	6-0426
21	8	SHOULDER BOLT, 3/8" DIA. X 5/8" LG.	6-0069
22	2	REAR SLIP PLATE	3-0197
23	2	BEARING CAGE	3-0196
24	1 SET	BALL BEARING	6-0829
26	11	SHEAVE ASSEMBLY	2-0557
27	21	NYLON THRUST WASHER	1-0757
28	1	REAR CROSSMEMBER WELDMENT	4-0188
29	4	LOCKING PIN ASSEMBLY	2-0637
30	4	SELF TAPPING SCREW, #10 X 1/2" LG.	6-0505
31	4	RAMP PIN	1-1887
32	4	COTTER PIN, 1/8" X 1 1/2" LG.	6-0978
33	16	HEX HD. BOLT, 1/4" - 20UNC X 3/4" LG.	6-0178
34	8	FLAT WASHER, 1/4" I.D.	6-0060
35	2	"CAUTION" TAPE, (40" LG.)	6-1125
36	2	RAMP ASSEMBLY W/ ROLLER	3-0905
37	3	POST	3-1114
38**	1	ALIGNMENT DECK WLDMT, (RIGHT SIDE)	4-0221
39	1	SHEAVE SPACER, 2 1/2" LG.	1-0798
40	1	SHEAVE SPACER, 1 1/2" LG.	1-0788

ITEM	QTY.	DESCRIPTION	PART#
41	4	DECK SHEAVE PIN	2-0566
42	4	SHOULDER BOLT, 3/8" DIA. X 1 1/2" LG.	6-0801
43	12	SHOULDER BOLT, 3/8" DIA. X 5/8" LG.	6-0069
44	4	LOCK SAFETY PIN	1-0769
45	4	CABLE ROLLER	1-0766
46	8	TENSION SPRING	1-0768
47	4	CROSSMEMBER SHEAVE PIN	1-0771
48	8	SHEAVE SPACER, 13/32" LG.	1-0786
49	4	SAFETY SHOE WLDMT.	2-0990
50	4	HEX NYLON LOCKNUT, 1/4"-28UNF	6-1563
51	4	COMPRESSION SPRING	1-0767
52	4	HEX NUT, 5/8"-18UNF	6-0662
53	4	INTERNAL TOOTH LOCKWASHER, 5/8" I.D.	6-0663
54	4	AIR CYLINDER, 5 1/2" ROD LGTH. (SPR-12)	6-0651
55	2	SAFETY LOCK WLDMT. LS	2-0567
	2	SAFETY LOCK WLDMT. RS	2-1475
56	8	PLASTIC BRACKET	1-0775
57	8	PLASTIC GUIDE	1-0776
58	8	HEX NUT, 5/8"-11UNC, GR.8	6-0036
59	2	SHEAVE SPACER, 1 3/4" LG.	1-0799
60	8	SET SCREW, 1/2"-13UNC X 1" LG. GR.8	6-0726
61	2	SHEAVE SPACER, 2" LG.	1-0943
62	16	FLAT WASHER, 1/4" ID x 3/4" OD, PLATED	2-0060
63	1	HYDRAULIC CYLINDER	4-0393
71	2	HEX NUT, 1"-14UNF-2A, GR.8	6-0664
72	1	CABLE FLANGE	2-0561
73	1	CLAMP	6-0665
74	2	HEX HD. BOLT, 3/8"-16UNC X 1 1/4" LG. GR.8	6-0666
80	4	HEX HD. BOLT, 3/8"-16UNC X 2 3/4" LG.	6-0730
81	4	SHEAVE COVER	2-0575
82	1	SERIAL TAG	6-1114
83	1	ALI/ETL DECAL	6-0996
85	1	DECAL SET, ALI/WL 200	6-0988
88	1	"ATTENTION" DECAL	6-1637

FOR SERVICE MODEL

*	1	SERVICE DECK WLDMT., (LEFT SIDE)	4-0272
**	1	SERVICE DECK WLDMT., (RIGHT SIDE)	4-0305

10.0 HYDRAULIC AND AIR KITS ASSEMBLY

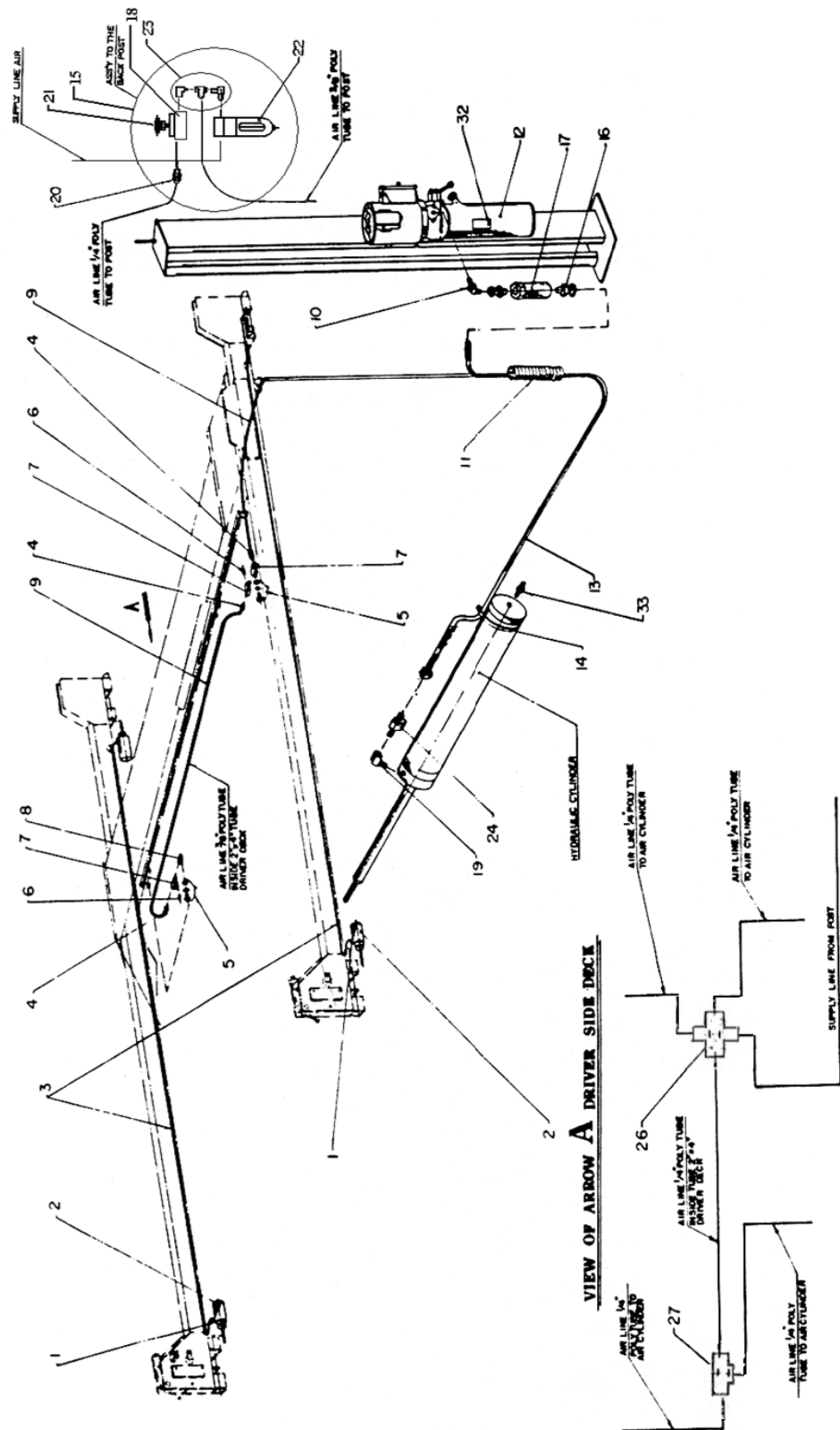

HYDRAULIC AND AIR KITS PART LIST

ITEM	QTY.	DESCRIPTION	PART#
1	4	90° ELBOW, 1/8" NPT X 1/4" POLY TUBE	6-0709
2	4	AIR CYLINDER	6-0651
3	50 FT.	1/4" DIA. POLY TUBE	6-0706
4	3	ADAPTER, 3/8" POLY TUBE X 1/4" NPT	6-0710
5	2	TERMINAL BOLT, 3/4"	6-0713
6	2	PLUG, 1/4" NPT	6-0282
7	3	1/4" NPT STREET TEE	6-0014
8	1	1/4" NPT STREET ELBOW	6-0015
9	25 FT.	3/8" DIA. POLY TUBE	6-0707
10	1	90° ADAPTER, 3/8" JIC M X 9/16"-18 M	6-0804
11	4 FT.	HOSE GUARD	6-0714
12	1	POWER PACK 230V/1PH/60HZ	6-1936
13	1	HYD.HOSE ASS'Y, 3/8" SWIVEL X 3/8" JIC M, 147" LG.	6-0715
14	3	CABLE TIE	6-0731
15	1	AIR VALVE & FILTER ASS'Y	2-1394
16	2	ADAPTER, 3/8" NPT M X 3/8" JIC F, SWIVEL	6-0797
17	1	FLOW CONTROL	6-1937
18	1	3-WAY AIR VALVE	6-1775
19	1	90° ELBOW, 1/4" NPT M X 3/8" NPT F	6-0796
20	1	ADAPTER, 1/4" POLY TUBE X 1/8" NPT	6-0708
21	1	AIR VALVE PUSHBUTTON KIT	6-1777
22	1	AIR FILTER ASSEMBLY	6-0772
	1	AIR FILTER ELEMENT, (REPLACEMENT)	6-0180
23	1	AIR VALVE FITTING KIT	0-0405
24	1	VELOCITY FUSE	6-1684
25	1	PLUG, 1/8" NPT	6-0182
26	1	1/4" POLYTUBE PUSHLOCK CROSS	6-3869
27	1	1/4" POLYTUBE PUSHLOCK TEE	6-2971
32	1	"LIFT OPERATION" DECAL	6-0593
33	1	ADAPTER, 1/8" NPT M X 1/4" JIC M	6-0280

11.0 CABLE ROUTING DIAGRAM

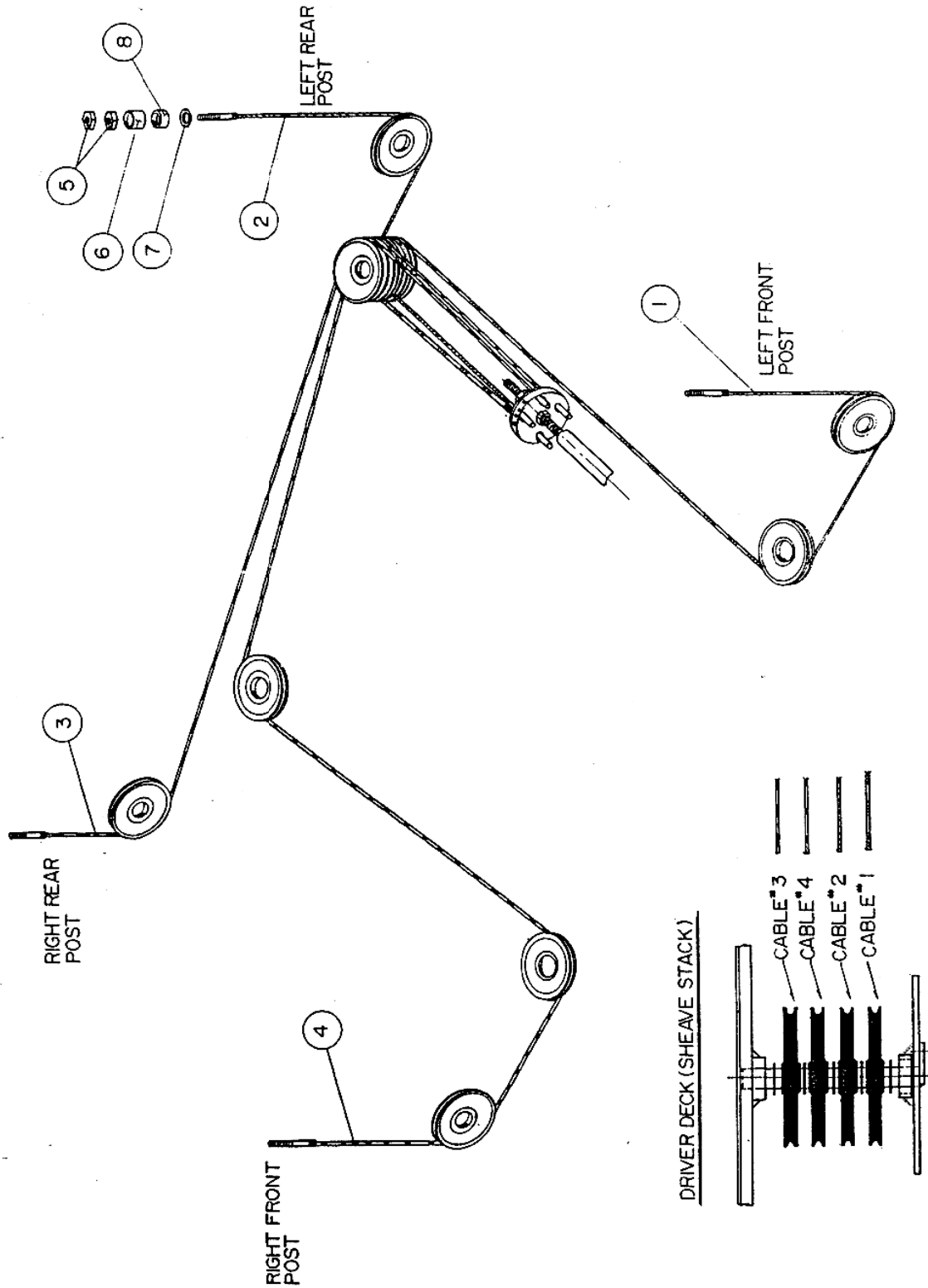

PARTS LIST

ITEM	QTY.	DESCRIPTION	PART#
1	1	CABLE ASSEMBLY, 318"LG. (LEFT-FRONT)	2-0643
2	1	CABLE ASSEMBLY, 151"LG. (LEFT-REAR)	2-0644
3	1	CABLE ASSEMBLY, 203"LG. (RIGHT-REAR)	2-0645
4	1	CABLE ASSEMBLY, 367"LG. (RIGHT-FRONT)	2-0646
5	8	HEX NUT, 7/8"-14UNF, GR.5	6-0724
6	4	CABLE SPACER, 2"LG.	1-0800
7	4	FLAT WASHER, 7/8" I.D.	6-0725
8	4	CABLE SPACER, 1"LG.	1-0801

12.0 SAFETY RETAINER BRACKET

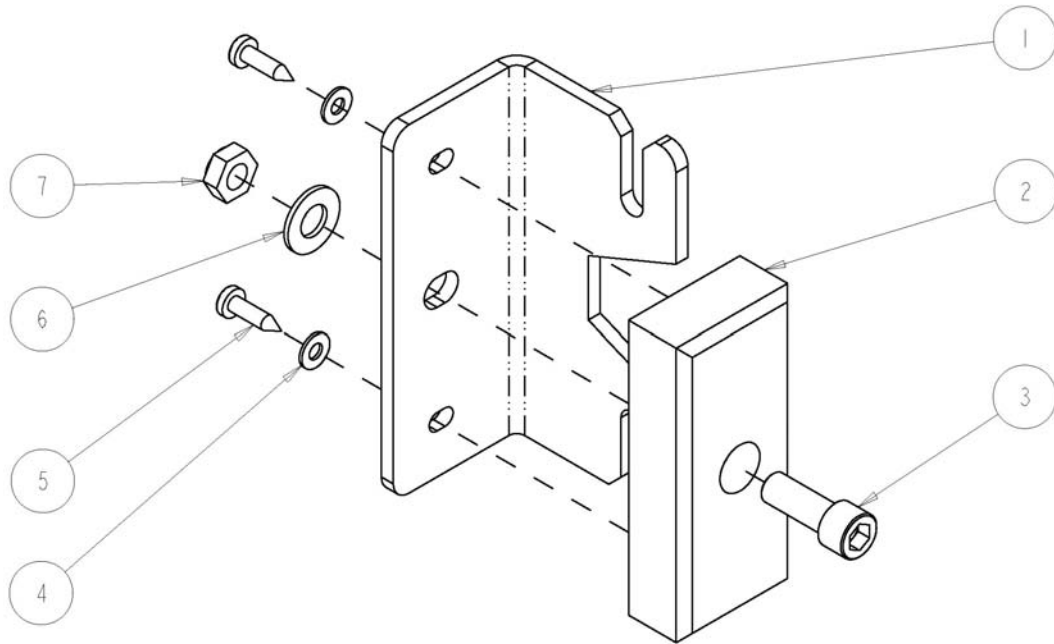

ITEM	QTY.	DESCRIPTION	PART #
1	8	SAFETY RETAINER BRACKET	2-2589
2	8	SAFETY RETAINER PAD	1-1674
3	8	SHCS 3/8" NC x 1" LG	6-2048
4	16	FLAT WASHER #10	6-0816
5	16	SCREW, SELF TAPPING, #10 x 3/4" LG	6-0297
6	8	LOCK WASHER 3/8"	6-0058
7	8	HEX NUT 3/8"-16 UNC GR5 PL	6-0034

13.0 POWER PACK: #6-1936 (AB-1400) 208-230V/1PH/60HZ

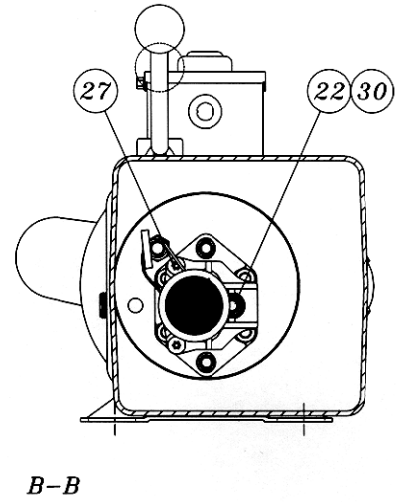
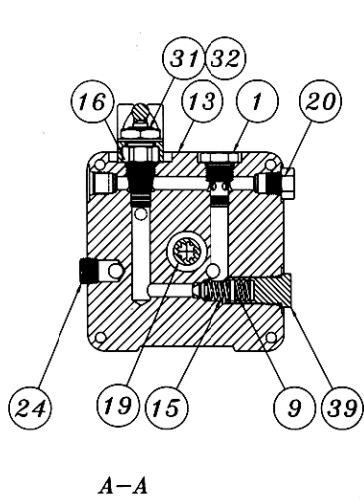
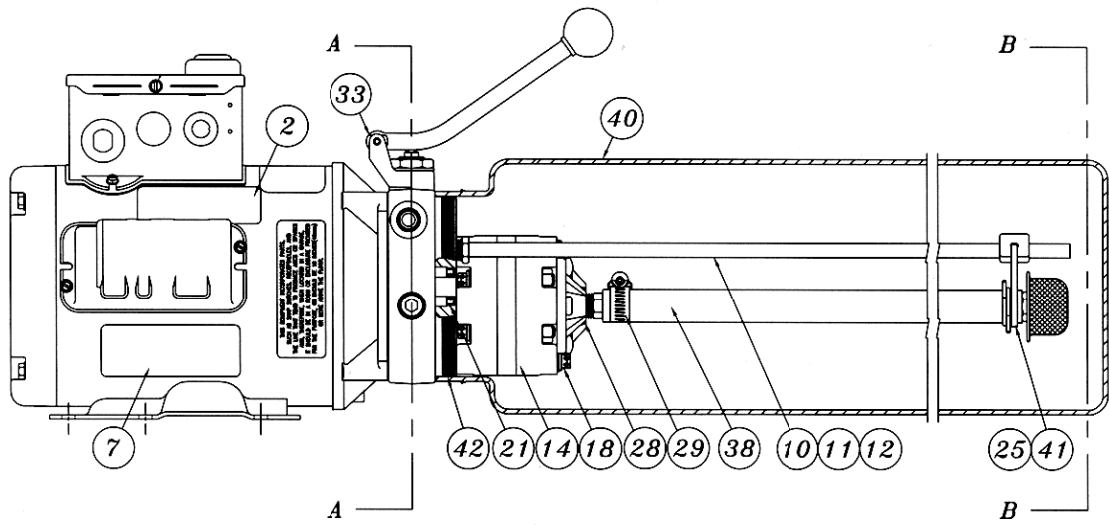
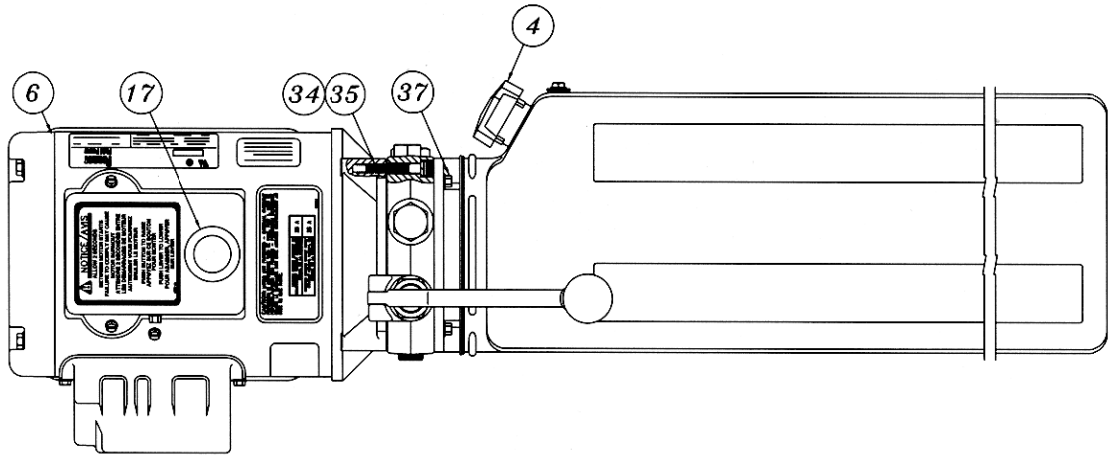

POWER PACK PARTS LIST: #6-1936 (AB-1400) 208-230V/1PH/60Hz

ITEM	QTY.	DESCRIPTION	PART #
1	1	VALVE CARTRIDGE CHECK	6-1087
2	1	LABEL INSTALLATION AUTOHOIST	6-2136
4	1	BREATHER CAP & BLADDER	6-1376
6	1	MOTOR AC 208-230V. 2HP/1PH/60Hz, BLK	6-2139
7	1	LABEL WARNING AUTOHOIST	6-2149
9	1	SPRING 0.480" x 0.063" x 0.42" COMP	6-2151
10	1	RETURN HOSE 3/8" OD x 21.5"	6-2152
11	1	COMPRESSION TUBE NUT	6-2153
12	1	COMPRESSION TUBE SLEEVE	6-2154
13	1	ENDHEAD UNIVERSAL AUTOHOIST	6-2155
14	1	PUMPASSY 3.1 CC/REV. SHORT SPLINE	6-1688
15	1	RELIEF ASSEMBLY FIXED 170 BAR	6-1317
16	1	VALVE CARTRIDGE RELEASE MANUAL	6-0880
17	1	WIRING ASSEMBLY AC 1PH FENNER	6-2156
18	2	BOLT 5/16"-24 x 3.00" TORX G8	6-1090
19	1	COUPLING SAE 9T-20/40 1.260"	6-0774
20	1	PLUMBING PLUG 9/16" SAE	6-2157
21	1	SEAL SHAFT 0.500" x 1.00" x 0.25"	6-2158
22	1	WASHER 0.338" x 0.625" x 0.060" STEEL	6-2159
24	1	PLUMBING PLUG 3/8" NPT	6-2161
25	1	PLUMBING MAGNET	6-2162
27	2	SCREW TAPTITE M6 x 1.0 12MM TORX	6-2164
28	1	COVER ASSY SUCTION	6-2165
29	1	PLUMBING CLAMP HOSE ADJ. INLET	6-2166
30	1	BOLT 5/16"-18 x 1.00" SHCS	6-1392
31	1	NUT 3/4"-16 x 1" HEX x 0.250" STEEL	6-2167
32	1	WASHER 3/4" INT. TOOTH LOCK	6-2168
33	1	BRACKET – HANDLE ASSY REL BLACK	6-0776
34	4	BOLT M6 x 1.0 35MM SOC HD	6-2169
35	4	WASHER 1/4" LOCK HI-COLLAR	6-2170
37	4	BOLT #12-24 x 0.50' HEX WSHRHD	6-1091
38	1	PLUMBING ASSY INLET 17.24 (3)	6-0786
39	1	RELIEF VALVE CAP ASSEMBLY	6-1089
40	1	TANK PLASTIC 6.7 OS 22.50" BLK	6-1399
41	1	CABLE TIE 8" LONG WHITE	6-1846
42	1	O-RING 2-348 BUNA	6-0875

CAUTION

ALL SAFETY LADDERS USED ON 4-POST LIFTS ARE PRELOADED.

REMOVING THE BOLT HOLDING THE BOTTOM PORTION OF THE SAFETY LADDER WITHOUT PROPER PRECAUTIONS CAN RESULT IN INJURY.

PLEASE CONTACT CUSTOMER SERVICE FOR PROPER REMOVAL INSTRUCTIONS.

