



**AIR-HYDRAULIC  
SLIDING JACKBEAM  
4500 lbs.**

**INSTALLATION AND OPERATION MANUAL**

---

**SAVE ALL INSTRUCTIONS  
READ ALL INSTRUCTIONS  
THOROUGHLY BEFORE  
INSTALLING, OPERATING,  
SERVICING, OR  
MAINTAINING THE LIFT.**



**6500 Millcreek Drive, Mississauga, Ontario, L5N 2W6  
Tel: (905) 826-8600  
Fax: (905) 826-7800**

**AUG 2009 REV. - 6-1477**

# JACKING BEAM INSTALLATION AND OPERATION MANUAL

The jacking beam should only be used with lifts installed on level concrete floors conforming to the installation instructions for the lift. Consult lift installation instructions for concrete thickness and strength requirements. Ensure clearance around and above lift conforms to installation instructions for the lift.



**ATTENTION!** This lift is intended for indoor installation only. It is prohibited to install this product outdoors. Operating environment temperature range should be 41 – 104 °F (5 – 40 °C). Failure to adhere will result in decertification, loss of warranty, and possible damage to the equipment.

Installation of lifts shall be performed in accordance with ANSO/ALI ALIS, Safety Requirements for Installation and Service of Automotive Lifts

For additional safety instructions regarding lifting, lift types, warning labels, preparing to lift, vehicle spotting, vehicle lifting, maintaining load stability, emergency procedures, vehicle lowering, lift limitations, lift maintenance, good shop practices, installation, operator training and owner/employer responsibilities, please refer to “Lifting It Right” (ALI/SM) and “Safety Tips” (ALI/ST).

For additional instruction on general requirements for lift operation, please refer to “Automotive Lift-Safety Requirements For Operation, Inspection and Maintenance” (ANSI/ALI ALOIM).

+ 070126-Quadra-WLSIA01

## SAFETY INSTRUCTIONS

If attachments, accessories or configuration modifying components that are located in the load path, affect operation of the lift, affect the lift electrical listing or affect intended vehicle accommodation are used on this lift and, if they are not certified for use on this lift, then the certification of this lift shall become null and void. Contact the participant for information pertaining to certified attachments, accessories or configuration modifying components.

[www.autolift.org](http://www.autolift.org)

©2007 by ALI, Inc.

ALI / WLSIA01

## Specifications

Maximum Capacity:	4500 lbs	2041 kg
Width Rail to Rail:	35-1/8"	892 mm
Down Position Height:	10-1/8"	257 mm
Maximum Raised Height:	20-5/8"	524 mm
Power Requirements:	90 – 120 psi Shop Air	
Shipping Weight:	290 lbs	132 kg

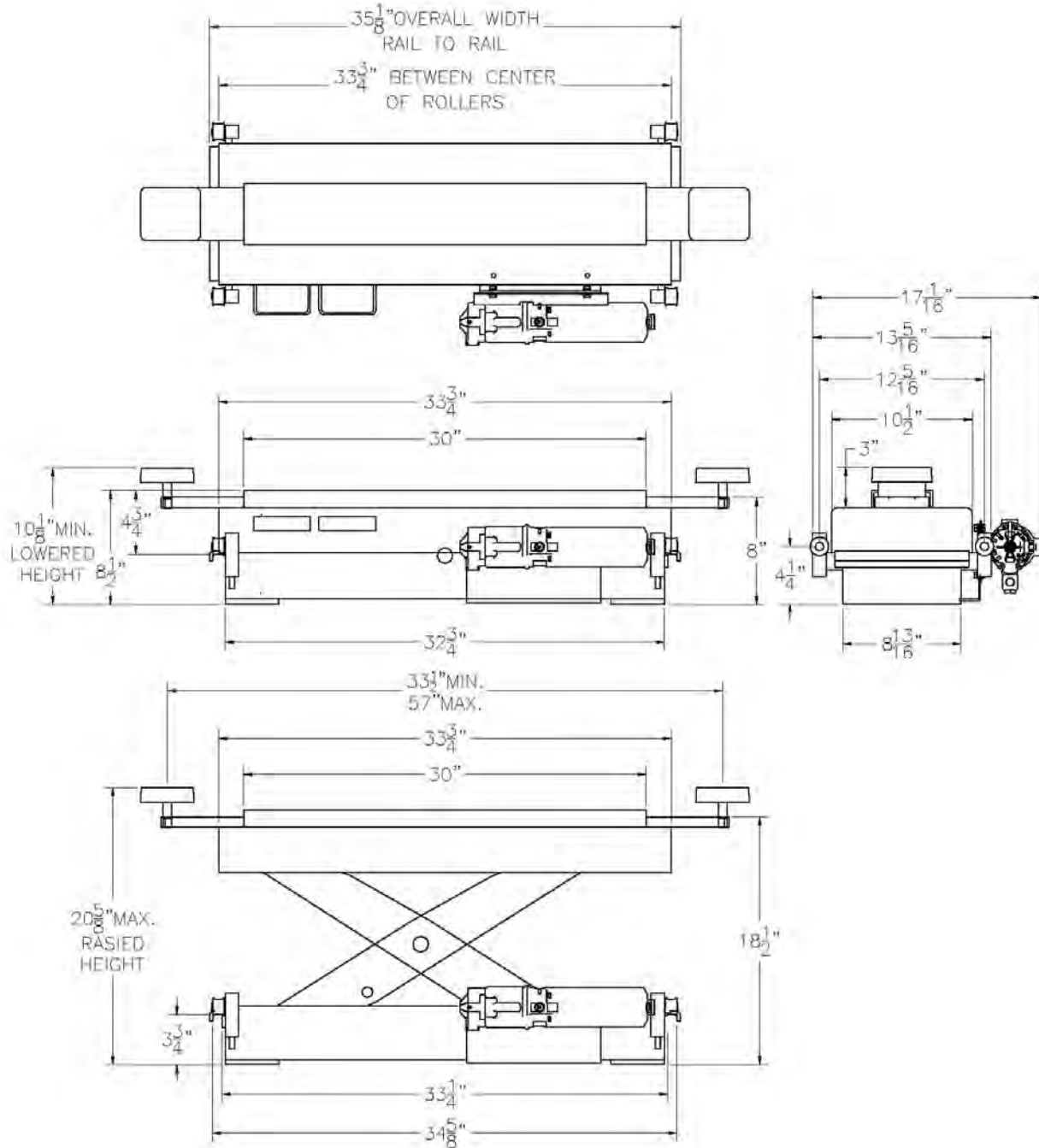

Figure 1- Jacking beam plan and elevation views

## **Contents**

The jacking beam is fully assembled and packaged to protect it from any damage that may occur during shipping. Included are the following components:

- Jacking beam assembly
- Jacking beam keeper kit

## **Installation**

1. Position the jacking beam on the lift so that the rollers rest on the rails on the inside edges of the runways. The pump side of the jacking beam should face outwards.
2. Bolt on the keeper brackets using the supplied hardware in the keeper kit.
3. The jacking beam must be connected to the air supply in order to operate. Install the ¼” nipple from the keeper kit on to the pump.
4. Attach ¼” NPT 90° elbow in the keeper kit to the ¼” nipple.
5. Attach the recoil hose to the ¼” NPT 90° elbow.
6. Attach the other end of the recoil hose to the air fitting on the side of the lift runway.

## Positioning of Vehicle on Jacking Beam

1. The vehicle must be positioned correctly on the lift prior to raising the vehicle with the jacking beam.

**LIFTING AN IMPROPERLY POSITIONED VEHICLE WITH THE JACK BEAM INCREASES THE POSSIBILITY OF ONE DECK LEADING OR LAGGING THE OTHER DECK.**

**NOTE: USE ONLY THE SAME LIFTING PADS ON BOTH ARMS.**

2. Move the jacking beam to the desired pickup area and connect the air line (if not permanently connected).

**NOTE: EASE OF POSITIONING WHILE JACKING BEAM IS NOT UNDER LOAD IS DUE TO THE TRACK ROLLER ASSEMBLIES. THE ROLLER ASSEMBLIES ARE SPRING LOADED TO CARRY THE WEIGHT OF THE JACK ONLY. WHEN THE JACKING BEAM IS UNDER LOAD THE JACK RESTS ON ITS STRUCTURE AND CANNOT BE MOVED.**

3. With the jacking beam positioned at the desired working location, select the proper lifting pads. Insert the lifting pads into the arms.

**NOTE: LIFT VEHICLE AT MANUFACTURER'S RECOMMENDED PICKUP POINTS ONLY. PLEASE REFER TO "LIFTING IT RIGHT" (ALI/SM).**

4. With the vehicle's center of gravity equally spaced between the decks, the jacking beam can be used to lift the vehicle. Select lifting points that are the same distance from the centerline of the vehicle, i.e. position the jack beam pads so that they make contact at the same point on each side of the vehicle.

## Raising the Jack Beam

1. Press the up button and hold until jacking beam is at full working height and the automatic safety is in place. Lower the jack beam onto the safety

**NOTE: NEVER WORK ON A VEHICLE UNLESS THE SAFETY LOCK IS ENGAGED AND THE JACKING BEAM CANNOT BE LOWERED.**

## **Lowering the Jack Beam**

1. To lower the jacking beam, first raise the jack up off the mechanical safety lock and release the safety lock using the safety release lever.

**NOTE: THE SAFETY LEVER MUST BE MANUALLY HELD IN THE RELEASED POSITION.**

2. Press the down button to release pressure allowing the jacking beam to lower to its full down position.
3. Never operate a jacking beam that is not in proper working order or in a manner not recommended by the vehicle or jacking beam manufacturer.

**ALWAYS ENSURE THAT THE MECHANICAL SAFETY IS ENGAGED WHENEVER A VEHICLE IS SUPPORTED BY THE JACKING BEAM.**

## **Recommended Maintenance**

1. Inspect the jacking beam on a daily basis to ensure the jacking beam is in proper working condition.
2. Make certain that the automatic safety drops into place when the jacking beam is raised and that it will release when held in the down position during lowering.
3. Check the hydraulic fluid when jacking beam is in the lowered position by removing the filler breather cap.
4. Keep the air source clean and make certain that an air filter is used to keep dirt out of the air motor.
5. Keep the entire jacking beam as clean as possible at all times.
6. To maintain a clean shop air supply, (oil, lube, filter and regulator) should always be in good working order in conjunction with the use of an oiler/separator.



ITEM	QTY.	DESCRIPTION	PART #
1	1	HYDRAULIC CYLINDER ASSEMBLY	3-0362
2	4	SLEEVE BEARING	6-0800
3	1	SLEEVE BEARING *	6-0799
4	1	WIPER RING *	6-0798
5	1	GLAND *	1-0880
6	1	PISTON ROD WELDMENT	2-0616
7	1	PISTON	1-0881
8	1	SEAL & WIPER RING *	6-0579
9	1	KEEPER WASHER *	1-0725
10	1	EXTERNAL SNAP RING *	6-0581
11	1	CYLINDER TUBE WELDMENT	2-0614
-	-	-	-
13	1	VELOCITY FUSE ASSEMBLY	1-1726
14	2	NEOPRENE RISER	2-1174
15	2	RISER, SHORT	2-0163
16	2	RISER, TALL	2-0164
17	2	LIFTING ARM	1-0047
18	1	SCISSOR PIN "B"	1-0584
19	2	UPPER CAM FOLLOWER	6-0076
20	4	SPACER	1-0228
21	2	HEX NUT, 5/8"-18UNF	6-0672
22	1	SAFETY PIN	1-0561
23	1	SAFETY STOP	1-0562
24	2	JAM NUT, 5/8"-18UNF	6-0040
25	4	ROLLER ASSEMBLY	2-0259
31	2	LOCKWASHER, 1/4"	6-0056
32	2	HEX HEAD BOLT, 1/4" - 20UNC x 3/4" LG.	6-0178
33	2	ARM STOP	1-0262
34	2	CAM FOLLOWER	1-0130
35	2	CLIP	6-0671
36	4	SPRING	6-0081
37	4	NYLON LOCKNUT, 3/8"UNC	6-0042
38	4	HEX HEAD BOLT, 3/8"-16UNC x 3/4" LG	6-0030
39	4	LOCKWASHER, 3/8"	6-0058
40	2	KEEPER BRACKET	1-0608
41	1	SNAP-IN GROMET	6-0670
42	1	BOTTOM FRAME WELDMENT	4-0154
43	1	LEVER WELDMENT	1-0589
44	1	KNOB	6-0251



ITEM	QTY.	DESCRIPTION	PART #
57	1	ADAPTER, W/ RESTRICTOR	1-1079
58	1	HYDRAULIC HOSE ASSEMBLY	1-0765
59	1	SCISSOR PIN "A"	1-0583
60	1	CENTER SHAFT	1-0574
61	2	RETAINING RING	6-0329
62	2	BOTTOM HINGE PIN	1-0599
63	6	SETSCREW, 1/4" - 20 UNC x 1/2" LG.	6-0438
64	4	RETAINING RING	6-0072
65	2	TOP HINGE PIN	1-0598
66	4	BUTTON HD SOC CS 1/4 x 3/8 NF	6-1881
67	2	THRUST WASHER	6-0328
68	1	TOP COVER WELDMENT	3-0433
69	1	SCISSOR ARM ASSEMBLY	3-0287
70	1	HYDRAULIC CYLINDER SEAL KIT *	0-0190
		<b>PARTS TO ATTACH PUMP</b>	
	1	AIR/HYDRAULIC PUMP	6-1428
	1	-ADAPTER, 3/8" POLY TO 1/4" NPT MALE	6-0710
	4	1/4"-20 x 3/4" LG GR8 HEX HEAD BOLT	6-0178
	4	1/4" SAE FLAT WASHER	6-0060
	4	1/4" LOCK WASHER	6-0056
	4	1/4"-20 HEX NUT	6-0032
	1	1/4" CLOSE NIPPLE	B7025371
	1	ELBOW 90° 1/4 NPT F X 1/4 NPT	60967

- **ITEMS LISTED WITH \* ARE INCLUDED IN ITEM 70 (SEAL KIT)**

# AIR / HYDRAULIC PUMP

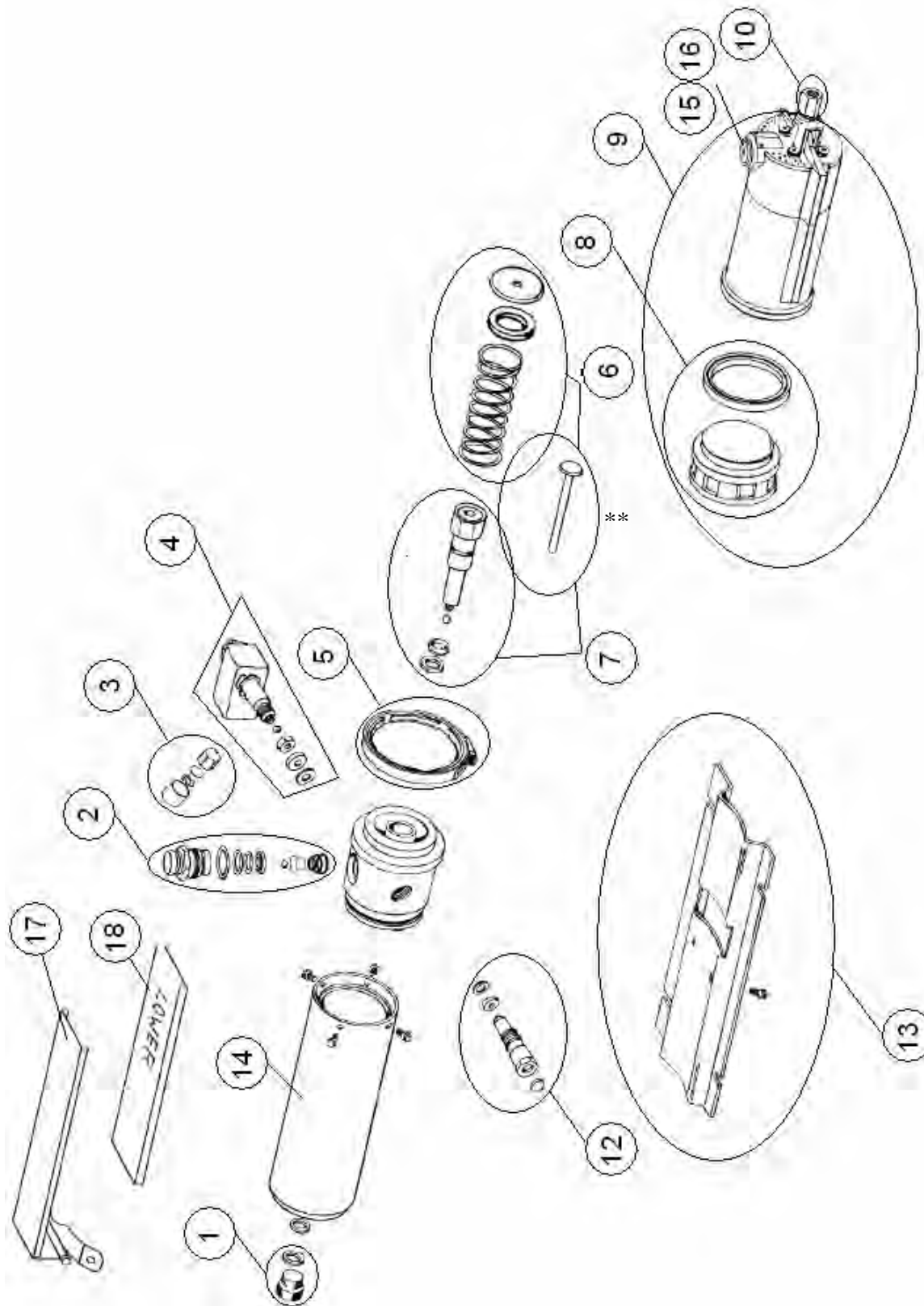

<b>ITEM</b>	<b>QTY.</b>	<b>DESCRIPTION</b>	<b>PART #</b>
1	1	RESEVOIR CAP ASSEMBLY	6-3348
2	1	RELEASE GUIDE ASSEMBLY	6-3349
3	1	FLOW RESTRICTOR ASSEMBLY	6-3350
4	1	COUPLER ASSEMBLY	6-3351
5	1	COUPLING V-RETAINER	6-3352
6	1	PLUNGER & SPRING KIT	6-3353
7	1	HYDRAULIC CYLINDER ASSEMBLY	6-3354
8	1	AIR PISTON ASSEMBLY	6-3355
9	1	AIR MOTOR ASSEMBLY	6-3356
10	1	COUPLER KIT	6-3357
12	1	RELIEF VALVE ASSEMBLY	6-3359
13	1	BASE	6-3360
14	1	RESERVOIR	6-3361
15	1	POPPET GUIDE ASSEMBLY	6-3365
16	1	BOOT	6-3368
17	1	RUBBER SLEEVE	6-3366
18	1	HANDLE	6-3367

\*\* The Plunger is included with both kits 6-3353 and 6-3354.