



Model 1800A
10 000 LB.
(ASYMMETRICAL)

**READ THIS INSTRUCTION MANUAL THOROUGHLY BEFORE
INSTALLING, OPERATING, SERVICING OR MAINTAINING THE
LIFT. SAVE THIS MANUAL.**

Table of Contents

1.0 SAFETY AND OPERATING INSTRUCTIONS	3
2.0 SPECIFICATIONS	5
3.0 PACKING LIST	6
3.1 MAIN STRUCTURAL COMPONENTS	6
3.2 ACCESSORY BOX.....	6
4.0 INSTALLATION REQUIREMENTS AND TOOLS	7
4.1 FOUNDATION	7
4.2 TOOLS	7
5.0 INSTALLATION INSTRUCTIONS	8
5.1 UNPACKING PROCEDURE	8
5.2 BAY LAYOUT	9
5.3 CROSSMEMBER INSTALLATION	10
5.4 SAFETY SHUT-OFF BAR INSTALLATION	12
5.5 ROUTING OF EQUALIZATION CABLE	13
5.6 ARM INSTALLATION	16
5.7 ARM RESTRAINT INSTALLATION	17
5.8 SAFETY RELEASE CABLE ROUTING AND ADJUSTMENT	18
5.9 POWER PACK INSTALLATION	20
5.10 HYDRAULIC SYSTEM INSTALLATION	21
5.11 HYDRAULIC SYSTEM BLEEDING	24
5.12 TOWER POSITIONING AND ANCHORING	25
5.13 POSITION AND ANCHORING OF REMAINING TOWER.....	27
5.14 SAFETY SHUT-OFF BAR ADJUSTMENT	30
5.15 FINAL CHECK OF ASSEMBLED LIFT	31
5.16 OPERATION TEST WITH VEHICLE	32
6.0 LIFT MAINTENANCE GUIDELINES	33
6.1 SAFETY INSTRUCTIONS	33
6.2 PERIODIC MAINTENANCE.....	33
7.0 SAFETY AWARENESS	34
8.0 PARTS LIST	35
8.1 HYDRAULIC SYSTEM	38
8.2 POWERPACK PARTS LIST.....	40
9.0 AVAILABLE ACCESSORIES	42

1.0 SAFETY AND OPERATING INSTRUCTIONS

1. When using this lift, basic safety precautions should always be followed, including the following.
2. Read all instructions in this manual and on the lift thoroughly before installing, operating, servicing or maintaining the lift.
3. Inspect lift daily. Do not operate if it malfunctions or problems have been encountered.
4. Never attempt to overload the lift. The manufacturer's rated capacity is shown on the identification label on the power side column. Do not override the operating controls or the warranty will be void.
5. Before driving vehicle between the towers, position the arms to the drive-through position to ensure unobstructed clearance. Do not hit or run over arms as this could damage the lift and/or vehicle.
6. Only trained and authorized personnel should operate the lift. Do not allow customers or bystanders to operate the lift or be in the lift area.
7. Position the lift support pads to contact the vehicle manufacturers recommended lifting points. Raise the lift until the pads contact the vehicle. Check pads for secure contact with the vehicle. Check all arm restraints and insure they are properly engaged. Raise the lift to the desired working height.
8. Some pickup trucks may require an optional truck adapter to clear running boards or other accessories.
9. **NOTE:** Always use all 4 arms to raise and support vehicle.
10. **Caution! Never work under the lift unless the mechanical safety locks are engaged.**
11. Note that the removal or installation of some vehicle parts may cause a critical load shift in the center of gravity and may cause the vehicle to become unstable. Refer to the vehicle manufacturer's service manual for recommended procedures.
12. Always keep the lift area free of obstruction and debris. Grease and oil spills should always be cleaned up immediately.
13. Never raise vehicle with passengers inside.
14. Before lowering check area for any obstructions.
15. Before removing the vehicle from the lift area, position the arms to the drivethru position to prevent damage to the lift and /or vehicle.
16. Do not remove hydraulic fittings while under pressure.
17. Flip pads must be positioned to flip down in opposite directions (mirror image) from front to back and side to side to prevent accidental vehicle shifting.

For additional safety instructions regarding lifting, lift types, warning labels, preparing to lift, vehicle spotting, vehicle lifting, maintaining load stability, emergency procedures, vehicle lowering, lift limitations, lift maintenance, good shop practices, installation, operator training and owner/employer responsibilities, please refer to “Lifting It Right” (ALI/SM) and “Safety Tips” (ALI/ST).

For additional instruction on general requirements for lift operation, please refer to “Automotive Lift-Safety Requirements For Operation, Inspection and Maintenance” (ANSI/ALI ALOIM).

Installation shall be performed in accordance with ANSO/ALI ALIS, Safety Requirements for Installation and Service of Automotive Lifts.



ATTENTION! This lift is intended for indoor installation only. It is prohibited to install this product outdoors. Operating environment temperature range should be 41 – 104 °F (5 – 40 °C). Failure to adhere will result in decertification, loss of warranty, and possible damage to the equipment.

+ 070126-Quadra-WLSIA01

SAFETY INSTRUCTIONS

If attachments, accessories or configuration modifying components that are located in the load path, affect operation of the lift, affect the lift electrical listing or affect intended vehicle accommodation are used on this lift and, if they are not certified for use on this lift, then the certification of this lift shall become null and void. Contact the participant for information pertaining to certified attachments, accessories or configuration modifying components.

www.autolift.org

©2007 by ALI, Inc.

ALI / WLSIA01

2.0 SPECIFICATIONS

Capacity:
 Capacity per arm:
 Overall Width:
 Width Between Columns:
 Drive-Thru Width:
 Overall Height:
 Under bar Clearance:
 Height to Lowered Lift Pads
 Height to Lift Pad (3" Adapter):
 Height to Lift Pad (6" Adapter):
 Rear Arm Retracted Length:
 Rear Arm Extended Length:
 Front Arm Retracted Length:
 Front Arm Extended Length:
 Maximum Lifting Height (6" Adapter):
 Lift Time:
 Power Requirements (Standard):

10000 lbs.	4536 kg
2500 lbs	1134 kg
138 5/8"	3520 mm
106 5/8"	2708 mm
87"	2201 mm
144"	3658 mm
140"	3556 mm
4 1/2"	114 mm
6 3/8"	162 mm
9 1/4"	235 mm
35 1/4"	896 mm
57 1/2"	1461 mm
21 7/8"	555 mm
32 7/8"	834 mm
78 1/2"	1194 mm
45 seconds	
208-230 Volts AC, 1 Ph., 60 Hz.	

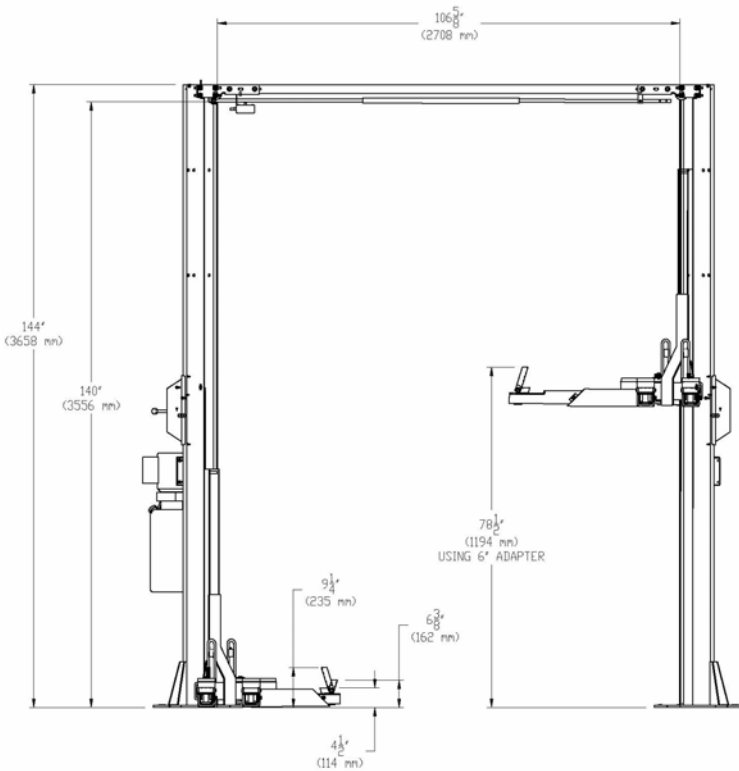

Figure 1 - Front View

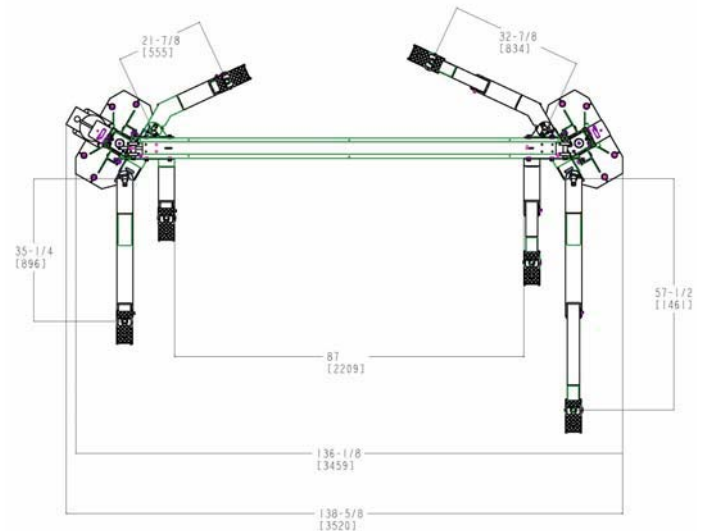

Figure 2 - Top View

3.0 PACKING LIST

The complete lift is contained in two (2) packages:

1. The **main structural components** are packed in a steel frame.
2. The remaining parts are packed in an **accessory box**.

3.1 MAIN STRUCTURAL COMPONENTS

- 1pc. - Power side tower and carriage assembly
- 1pc. - Slave side tower and carriage assembly
- 1pc. - Crossmember
- 1pc. - Actuator Bar w/ foam

3.2 ACCESSORY BOX

- 4pcs. - Locking Arm Assembly w/arm pins
- 2pcs. - Safety Covers w/Decals
- 1pc. - Hardware Package w/Packing List
- 1pc. - Actuator Extension
- 1pc. - Actuator Mounting Bracket
- 1pc. - Power Pack
- 4pc. - Arm Restraint
- 1pc. - Safety Release Cable
- 1pc. - Hydraulic Hose (Long)
- 1pc. - Hydraulic Hose (Short)
- 2pcs. - Equalizing Cable w/Hex Nuts
- 1pc. - ALI manual "Lifting It Right"
- 1pc. - Automotive Lift Safety Tips
- 1pc. - Automotive Lift, Operation, Inspection and Maintenance manual
- 1pc. - "ALI" Quick Reference Guide
- 1pc. - Owner's manual
- 1pc. - Safety Shut-off Microswitch Assembly (Components)

4.0 INSTALLATION REQUIREMENTS AND TOOLS

4.1 FOUNDATION

IMPORTANT: It is the user's responsibility to provide a satisfactory installation area for the lift. Lifts should only be installed on level concrete floors with a minimum thickness of four and a quarter inches (4 $\frac{1}{4}$ ") or 108 mm. Concrete must have a minimum strength of 3000 psi or 21 MPa and should be aged thirty (30) days prior to installation. Please consult the architect, contractor or engineer if doubt exists as to the strength and feasibility of the floor to enable proper lift installation and operation.

It is the user's responsibility to provide all wiring for electrical hook-up prior to installation and to insure that the electrical installation conforms to local building codes. Where required, it is the user's responsibility to provide an electrical isolation switch located in close proximity to the lift that will enable emergency stop capability and isolate electrical power from the lift for any servicing requirements.

4.2 TOOLS

Tools Required

- a. 16ft. Measuring Tape
- b. Chalk Line
- c. Rotary Hammer Drill
- d. 3/4" diameter Masonry Drill Bit
- e. Hammer
- f. SAE Wrenches and Ratchet Set
- g. 2ft. Level
- h. 4ft. Level
- i. Crow Bar
- j. 12ft. Step Ladder
- k. Side Cutters
- l. Screwdrivers
- m. 4" x 4" Wooden Blocks (for unpacking)
- n. Wherever LOCTITE symbol is shown, apply LOCTITE #242 on required fasteners. If fasteners are removed reapply LOCTITE before re-installing.



5.0 INSTALLATION INSTRUCTIONS

When the lift arrives on site:

- Read the owner's manual and make sure the installation instructions are fully understood.
- Check for any freight damages.
- Check the contents of the accessory and hardware boxes to make sure no parts are missing.
- Gather all the tools listed above.

5.1 UNPACKING PROCEDURE

- 5.1.1 **Important!** Place the main structural components on wooden blocks so that the steel shipping frames can be removed.
- 5.1.2 Remove the plastic wrapping.
- 5.1.3 Remove the crossmember, and the actuator bar.
- 5.1.4 Unbolt the steel shipping frames.
- 5.1.5 Lay each tower on the floor with the carriage side up.
- 5.1.6 Check the installation area for obstructions. (Lights, Heating Ducts, Ceiling, Floor Drains, etc.)

5.2 BAY LAYOUT

- 5.2.1 Prepare the bay by selecting the location of the lift relative to the walls.
- 5.2.2 Clear the installation area of all packaging materials to avoid trip hazards.
- 5.2.3 Measure midpoint of door.
- 5.2.4 Using measuring tape scribe two arcs, equal distance from the midpoint.
- 5.2.5 The centerline of the lift occurs between the intersection of the arcs and the midpoint of the door. Refer to Figure 3.

Note: Leave any additional room for any desired aisle or work area. Recommended minimum clearance around lift is three feet (3 ft) and above lift is four inches (4"). Ensure clearance conforms to local building and fire codes.

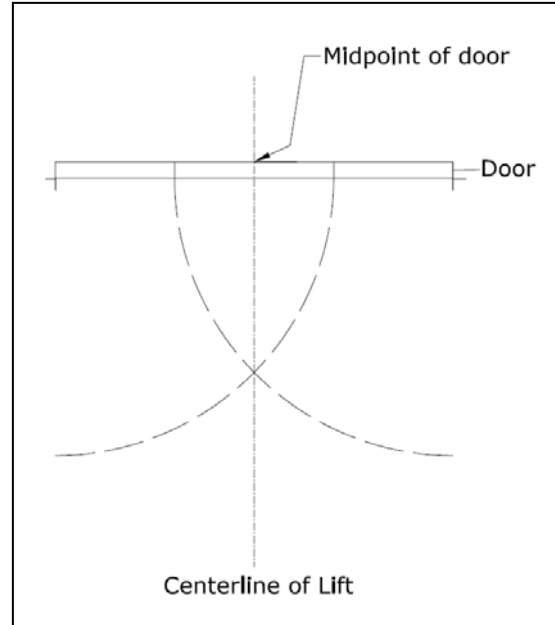

Figure 3. Chalk line

- 5.2.6 Measure the specified distance (") to draw a second chalk line at 90° for locating the lift towers. Refer to Figure 4.
- 5.2.7 The lift is centered between the door and the walls of the area.

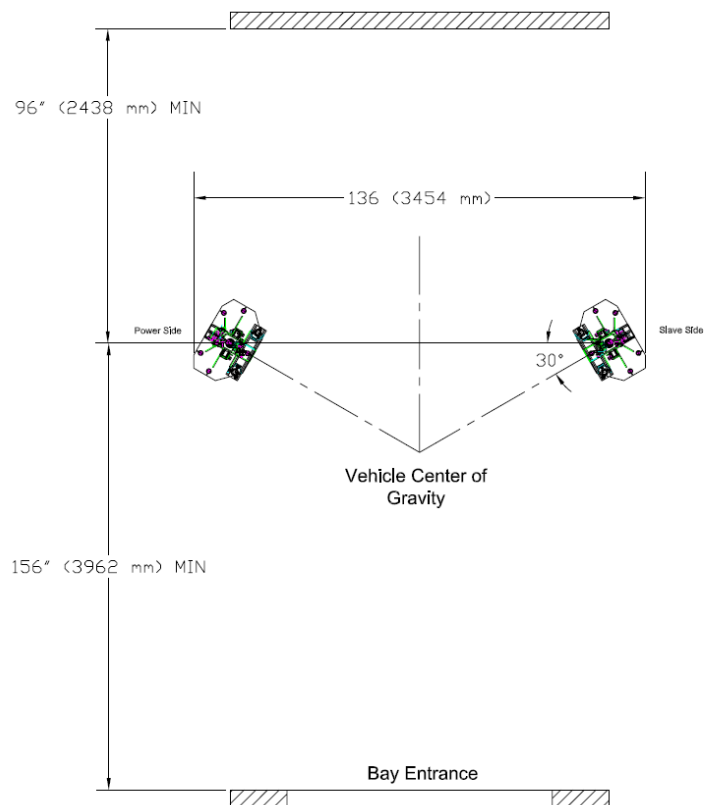
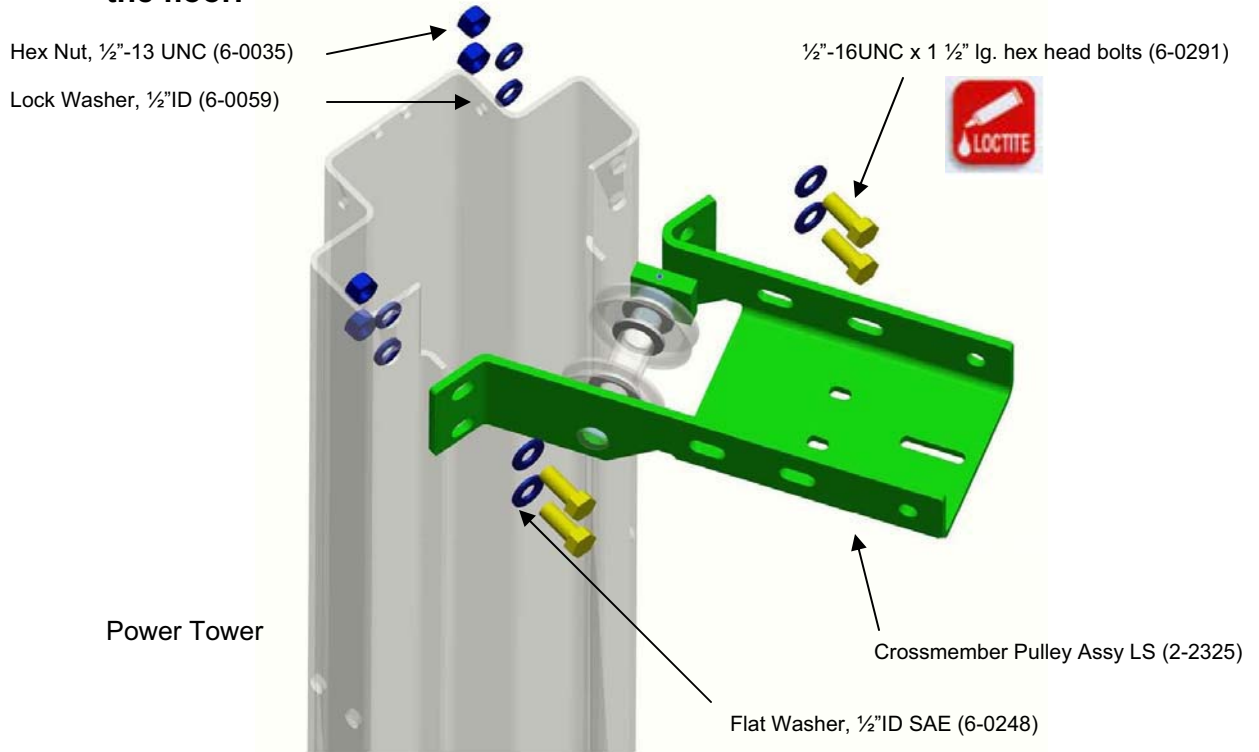

Figure 4. Bay Layout

5.3 CROSSMEMBER INSTALLATION

5.3.1 Install the cross member bracket to the two towers. **While it is still on the floor.**



5.3.2 Install the safety pulley bracket complete with pulley on each tower.

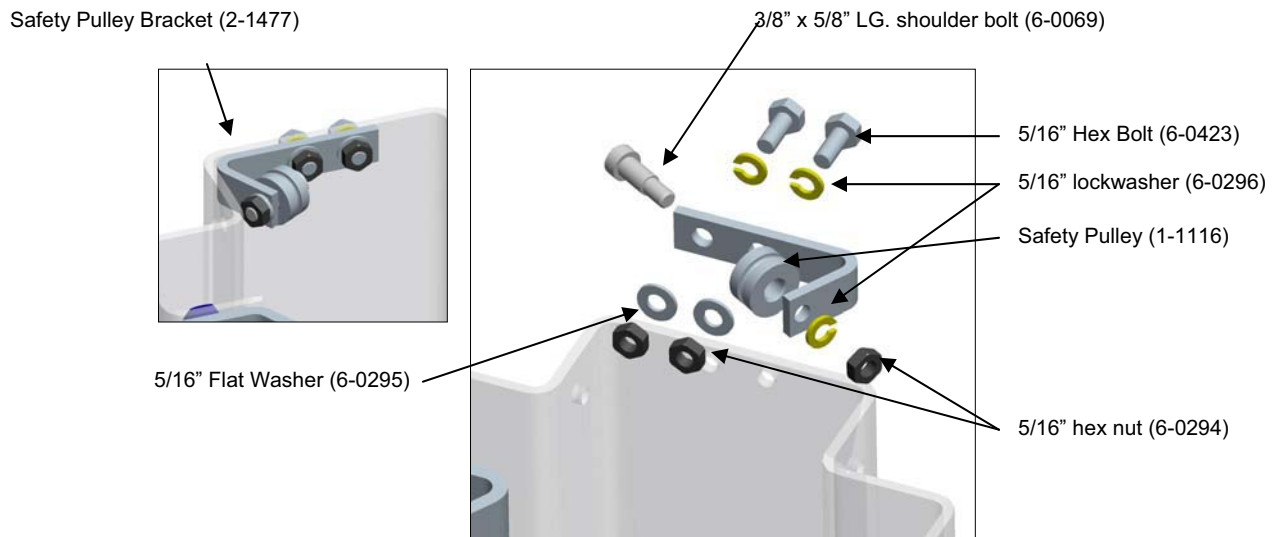

5.3.3 Stand towers in the position shown.

5.3.4 Using a stepladder, install the crossmember. Install and tighten bolts.

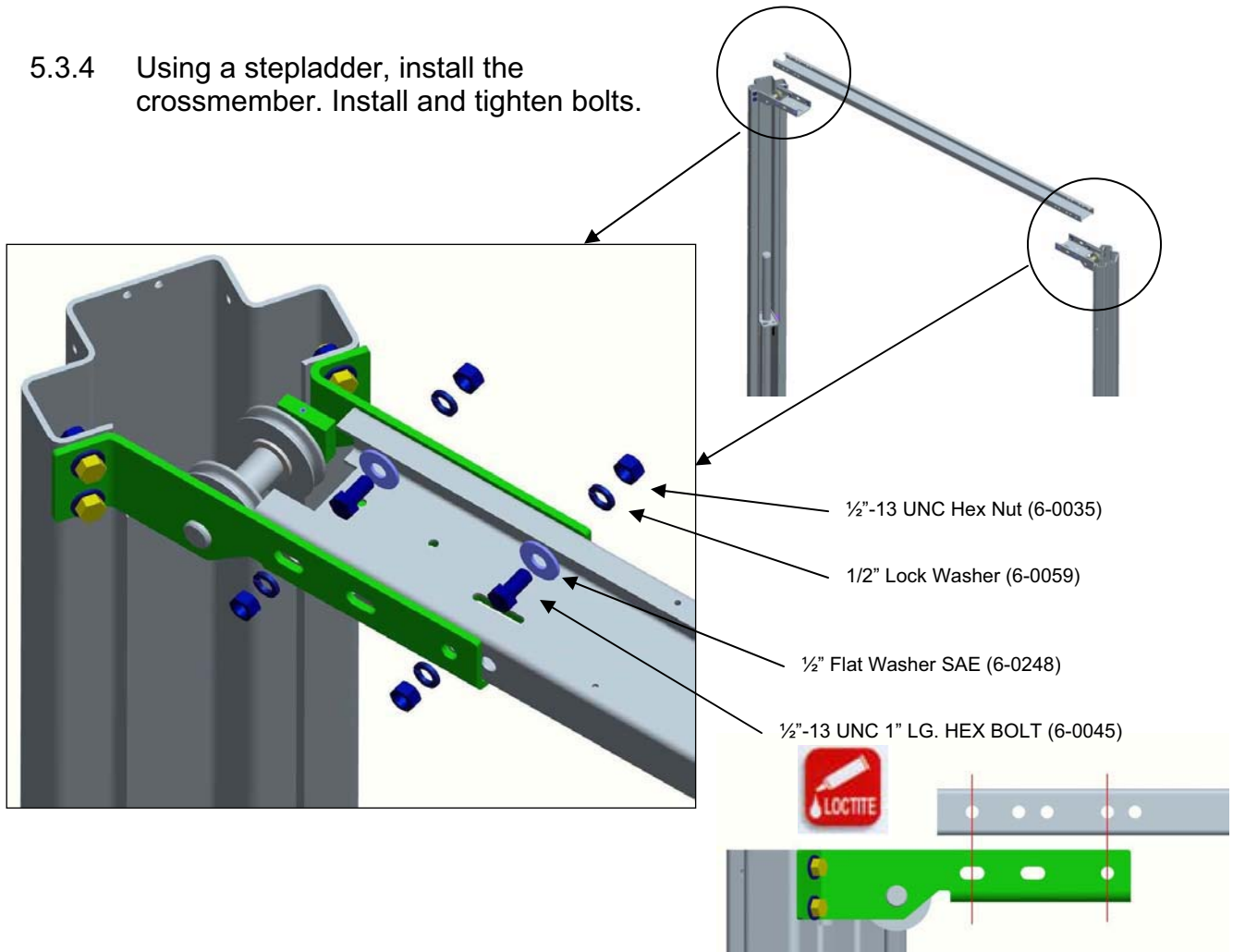

5.4 SAFETY SHUT-OFF BAR INSTALLATION

The safety shut off will disconnect the power to the power pack when an obstruction touches the padded bar or the carriages reach their maximum height. The safety shut off switch is factory pre-wired.

5.4.1 Attach the Actuator Mounting Bracket (1-1378) to the crossmember

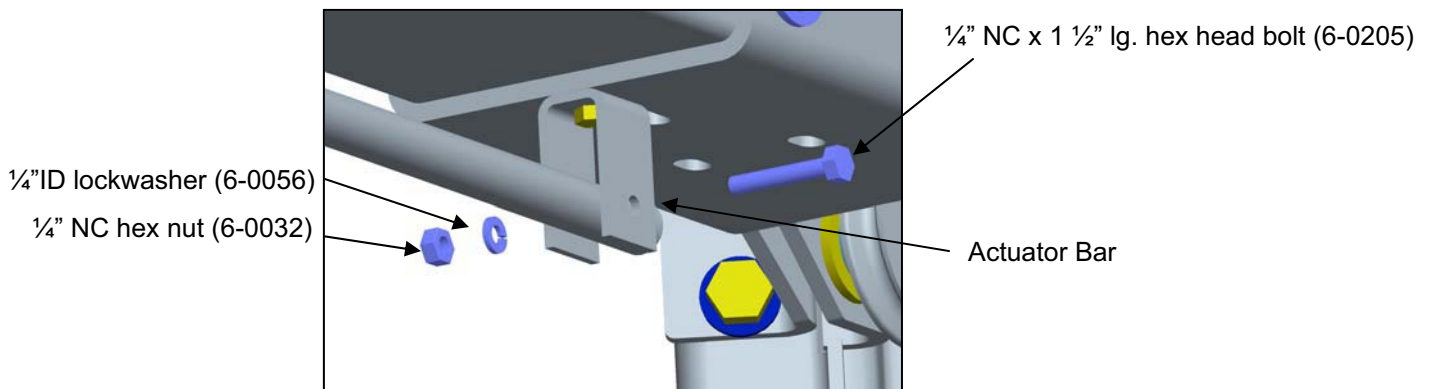
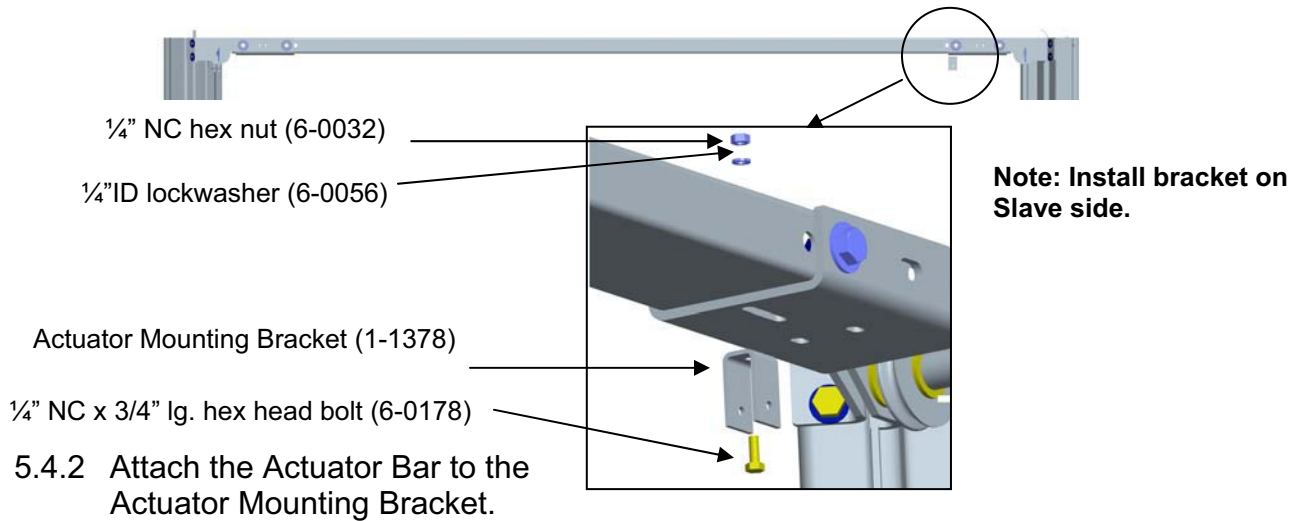

5.4.3 Slide Safety Shut-Off Microswitch Assembly over the open end of actuator bar.

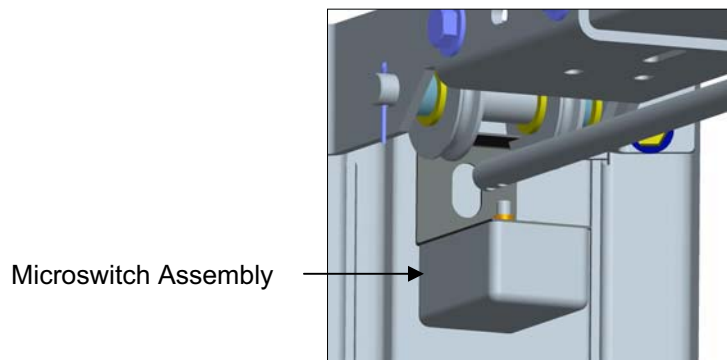

5.4.4 Bolt the assembly to the crossmember.

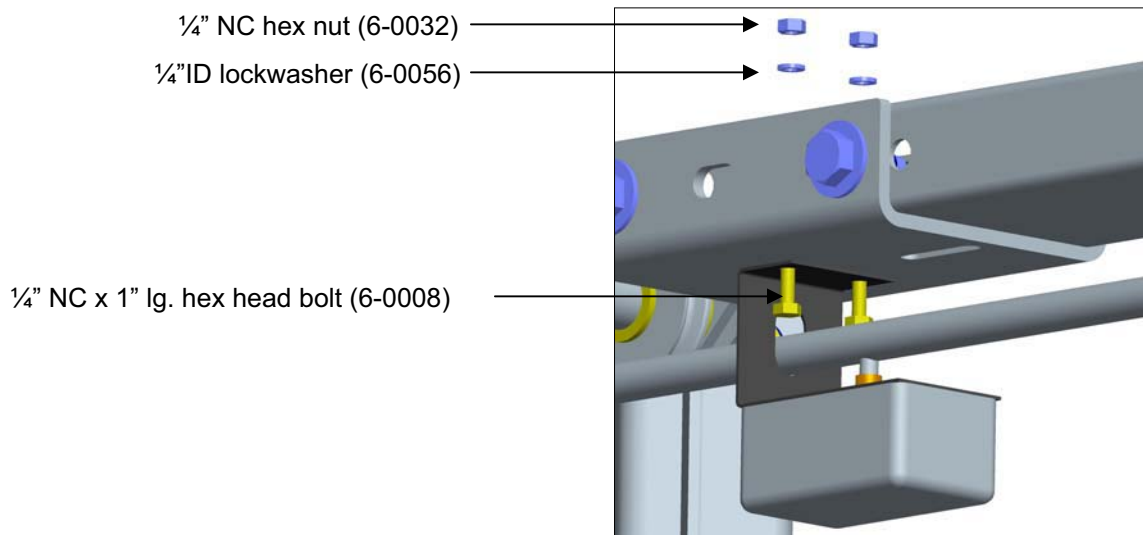

5.5 ROUTING OF EQUALIZATION CABLE

5.5.1 Manually lift the carriages to the first safety latch.

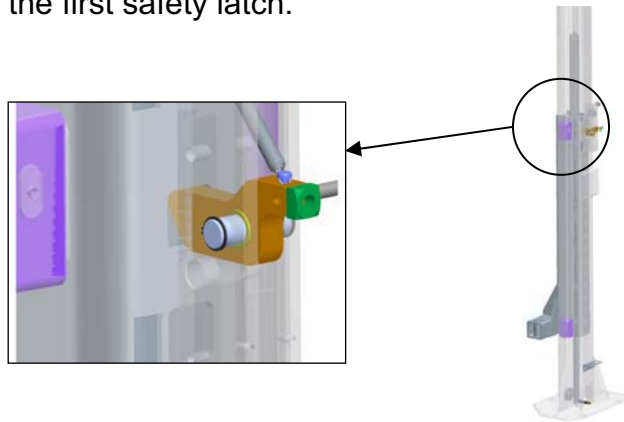

5.5.2 Remove equalizing cables (1-1786) from the accessory kit box, and 8 1/2"- 13UNC nuts from a polybag in the hardware kit box.

5.5.3

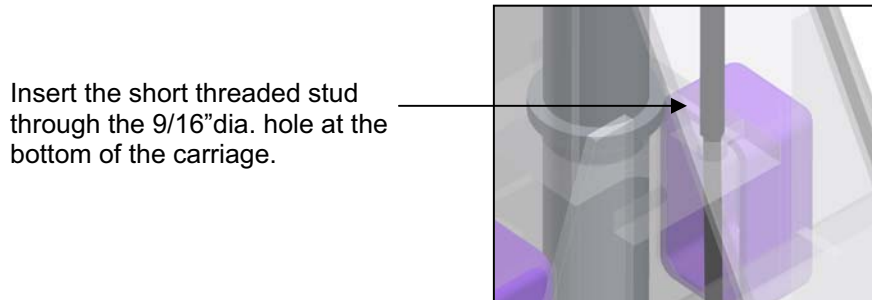

Pass the cable until it reaches the top opening. Tighten a ½"-13UNC nut to the center of the stud, and then **firmly tighten** a second nut up against it using two wrenches.

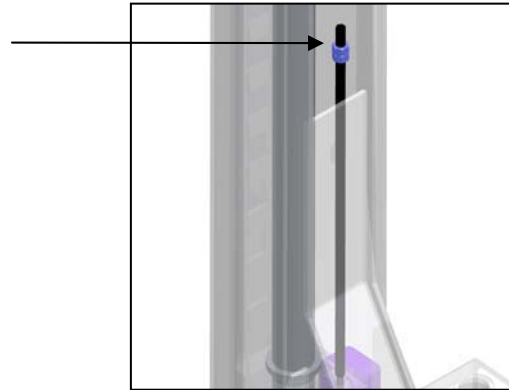

5.5.4 Pull the cable back down on to the carriage bottom plate.

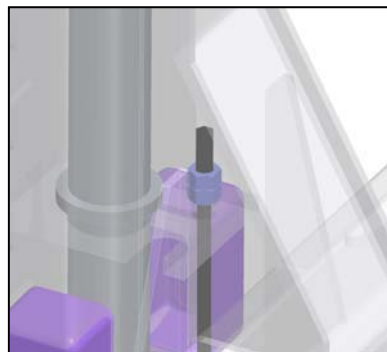

5.5.5 At the bottom of the column, remove the hitch pin, pulley pin and pulley from the base plate.



5.5.6 Route equalizing cable around pulley and reassemble the pulley to the base plate. **IMPORTANT – Hitch pin must be installed securely.**



5.5.7 Route Cable as shown.

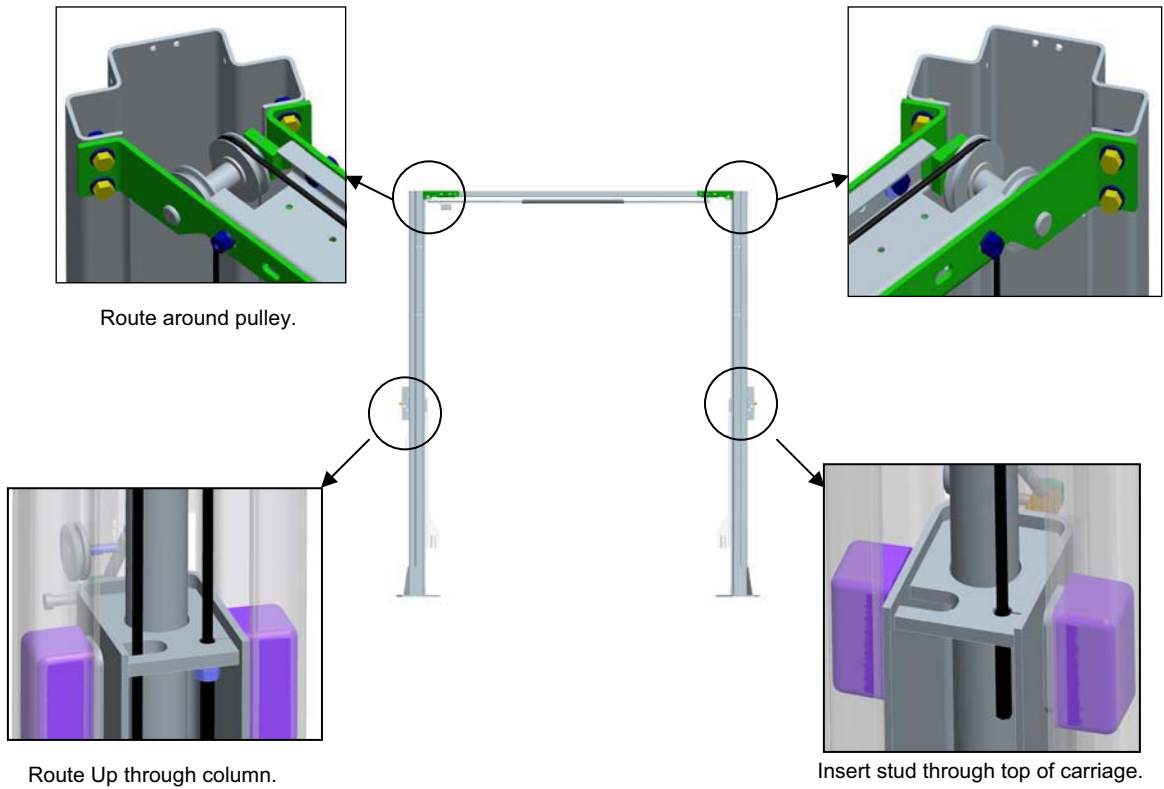

5.5.8

Use a wrench to hold the top of the threaded stud to prevent it from rotating.

Hand tighten (2) $\frac{1}{2}$ "-13 UNC nuts onto the threaded stud enough to remove all visible cable slack

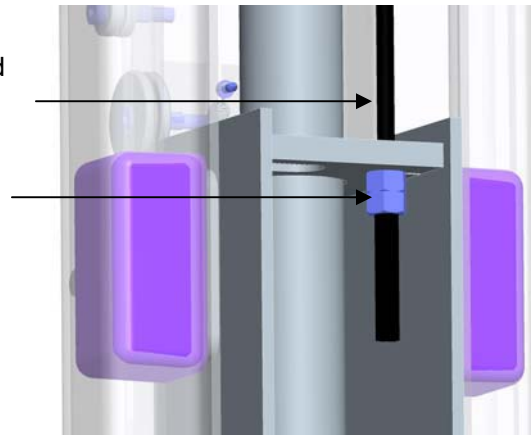

5.5.9

Hold the top of the threaded stud using wrench.

Tighten the first nut approximately $1\frac{1}{2}$ " to tension cable.

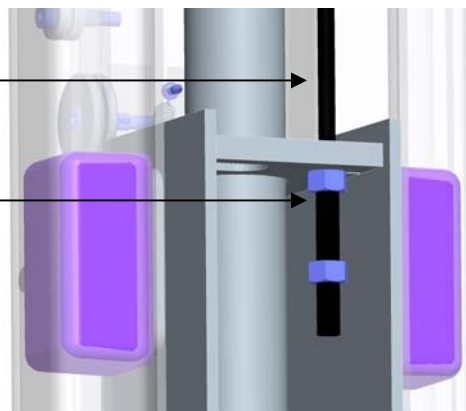

5.5.10

Tighten the second nut firmly against the first one.

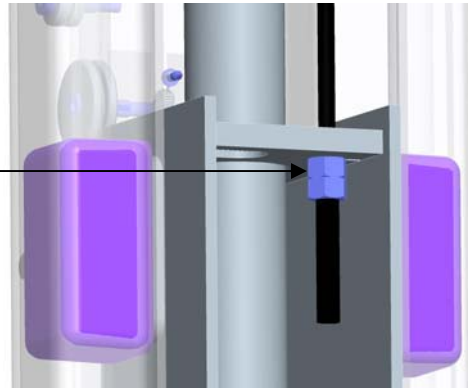

5.5.11 Repeat steps for other cable.

5.6 ARM INSTALLATION

5.6.1 Remove the Arm Pins from all four Arms.

5.6.2 Install the four arms on the carriages by inserting the arm pins.

5.6.3 Install Arm Restraint Gear.

5/16" -18UNC x 1 1/4" LG. hex head bolt (6-2059)



5/16" Flat Washers (6-0295)

Arm Restraint Gear (1-2618)

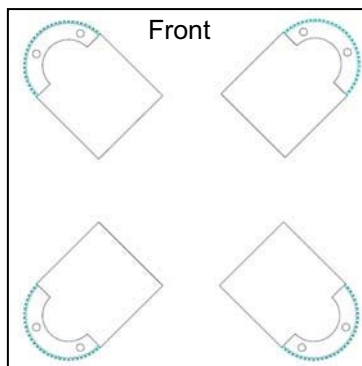
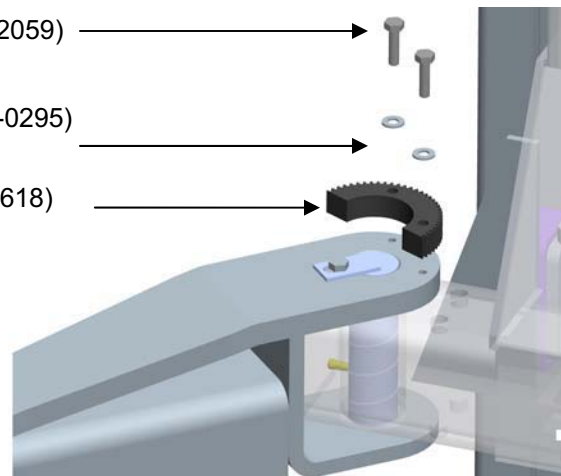

Orientation of Gears.

Note: Arm may not be as shown.

5.7 ARM RESTRAINT INSTALLATION

- 5.7.1 Insert arm lock handle weldment (1-2914) through holes in carriage weldment.

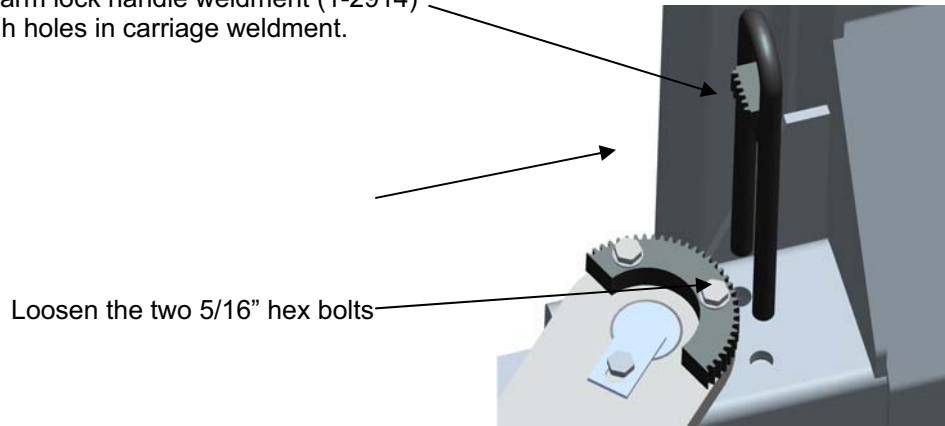

- 5.7.2

Adjust arm restraint gear so that lock engages smoothly through entire range of arm motion. **Tighten both 5/16 hex bolts.**

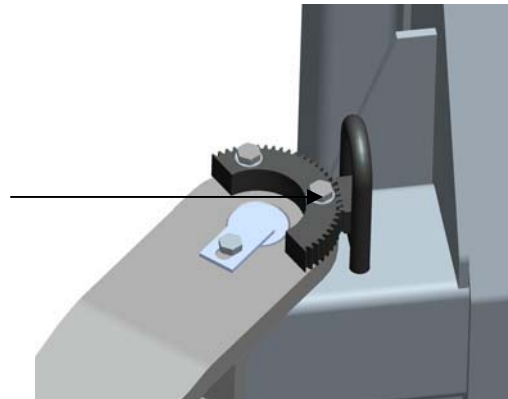

- 5.7.3 Repeat above steps for all arms.

- 5.7.4 Slide arm lock spring over outboard leg of arm lock handle (leg which is nearest tower).

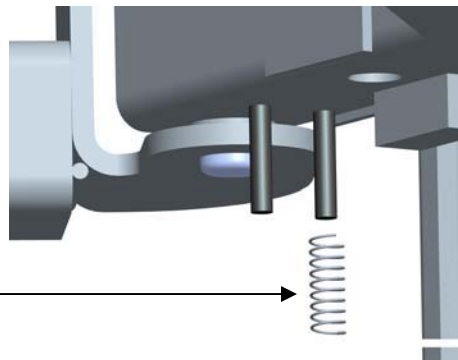

- 5.7.5 Hammer a spring retainer cap to the end of the arm lock leg.

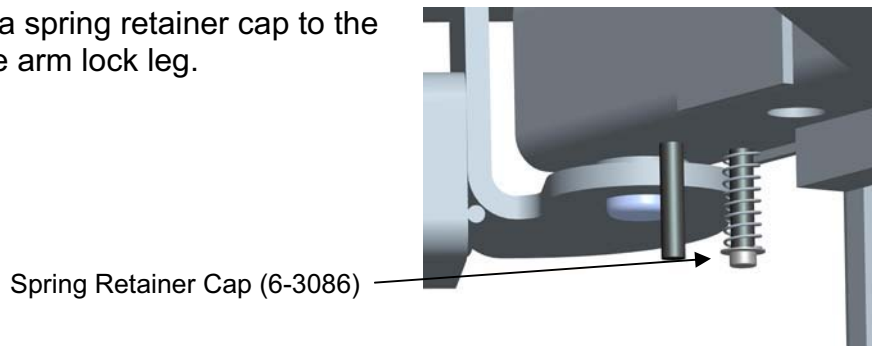

5.8 SAFETY RELEASE CABLE ROUTING AND ADJUSTMENT

The mechanical safety automatically engages. To release the mechanical safety, you must first raise the lift approximately 2", then pull the safety release lever down. This disengages the power side safety dog and activates the safety cable to release the slave side safety dog.

- 5.8.1 Install the safety release handle (1-1113) onto the power side safety dog.

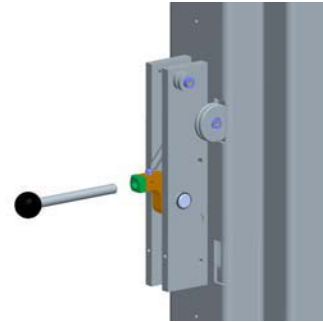

- 5.8.2

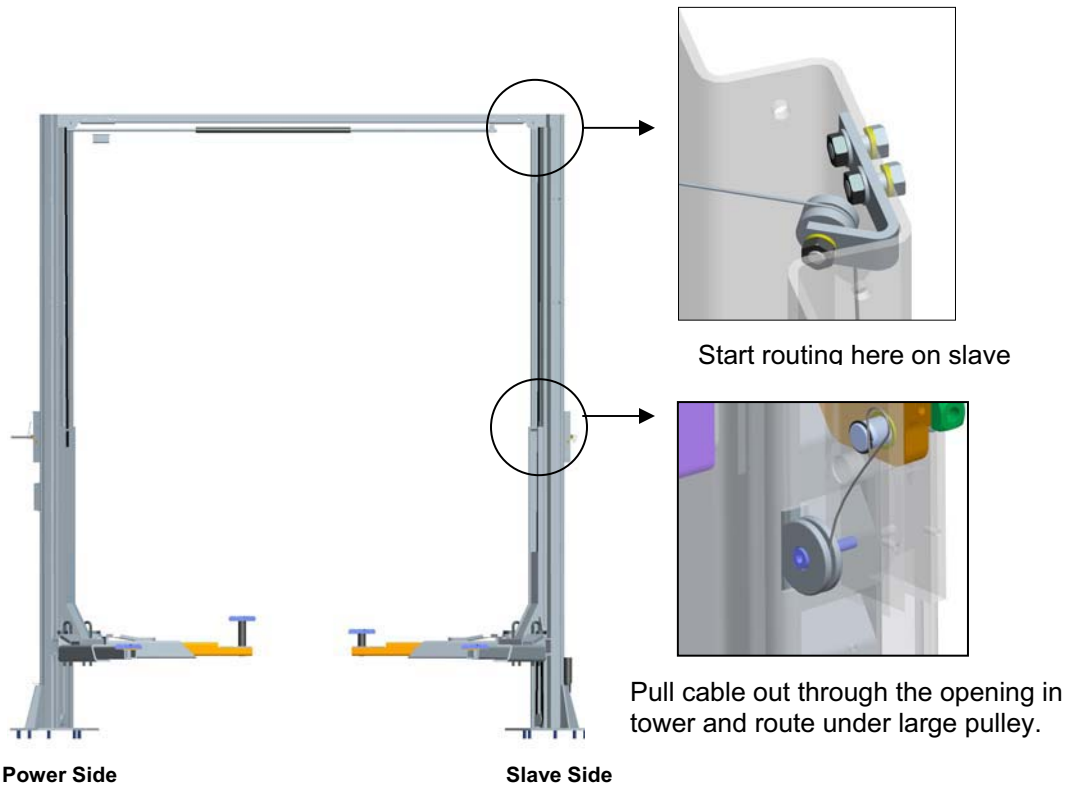

5.8.3 Fix the collar of the safety release cable to the shoulder bolt on the safety dog.

NOTE: Make sure shoulder bolt, 3/8" dia. x 1 1/2" lg. (6-0801), is lock tight to safety dog.

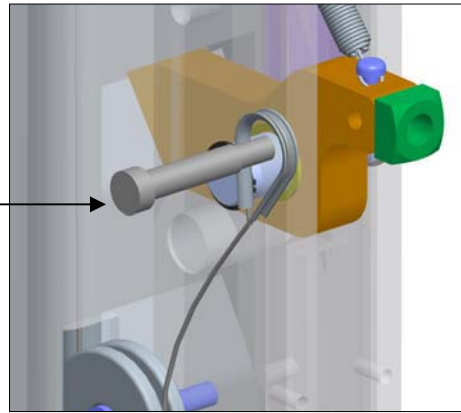

5.8.4

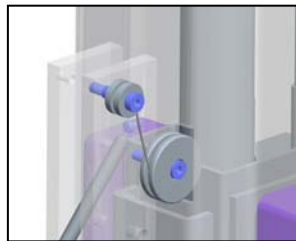

Guide the cable up under the large pulley on the power side

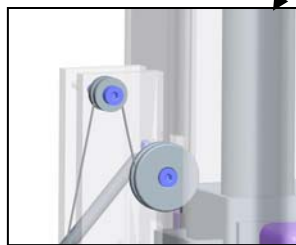

Over the small pulley towards the safety dog.

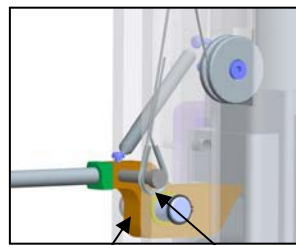
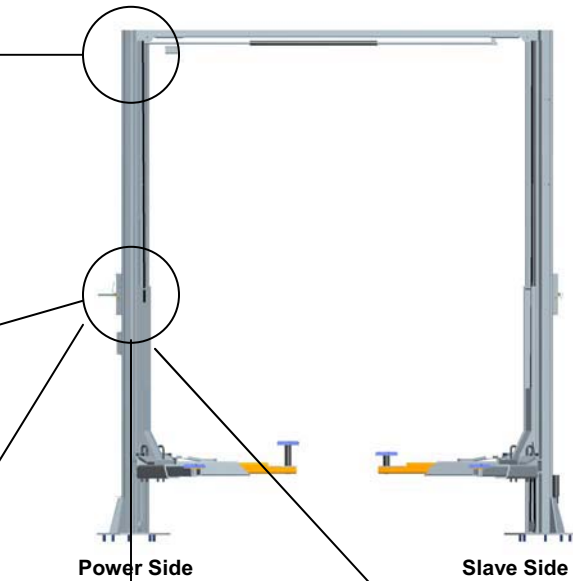

Wrap around the Thimble (6-2074)

3/8" x 1 1/2" lg. shoulder bolt (6-0801)

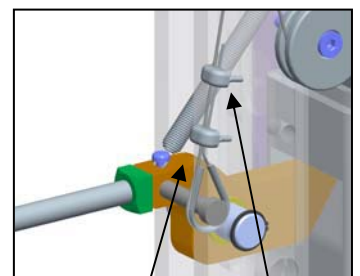

Clamp using wire rope clips (6-2060)



Do not tighten fully at this stage.

5.8.5 Adjust the cable length so that both safety dogs travel from full engagement position to full release position when the safety release handle is pulled.

Tighten both wire rope clips firmly when adjustment is completed.

5.9 POWER PACK INSTALLATION

- 5.9.1 Remove the **red** plastic cap located at the rear of the power pack, and install the "T" fitting located in the hardware kit.

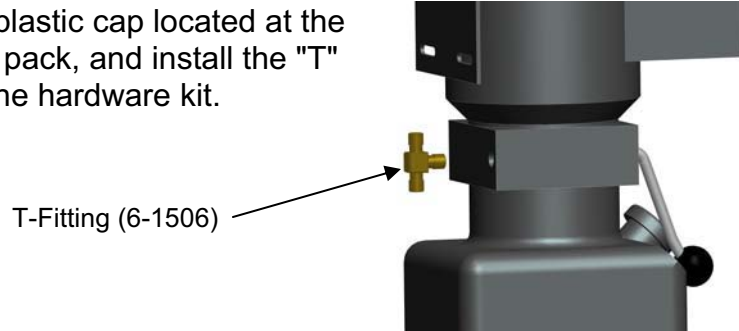

- 5.9.2 Bolt power pack to the mounting bracket on the power side tower using hardware from the kit. **Do not tighten.**

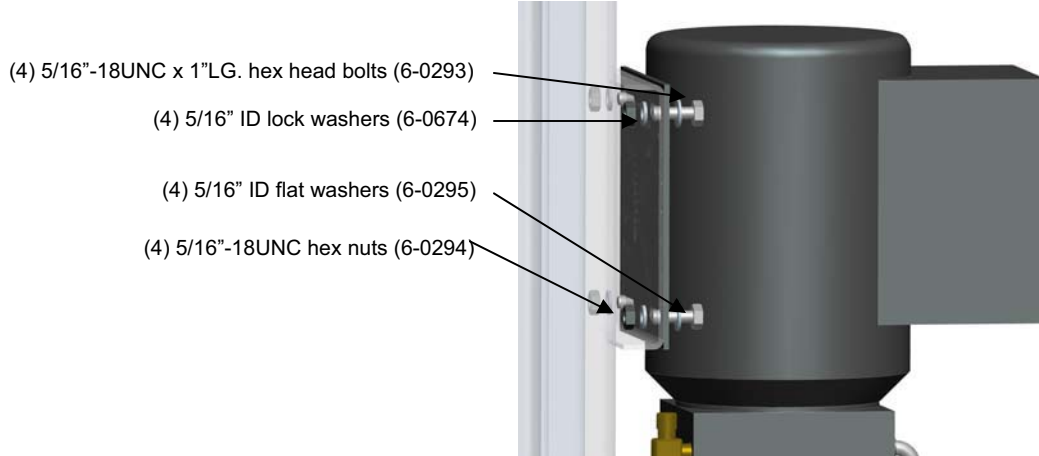

- 5.9.3 Remove the filler cap from the powerpack and fill the reservoir with approximately 4.5 Gal. (18L) of ISO32 hydraulic oil (10 wt. hydraulic oil).

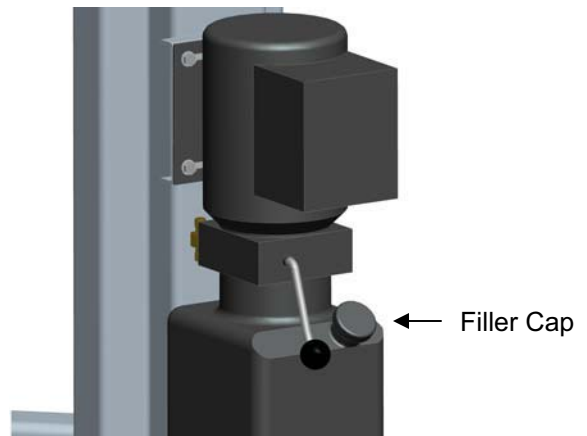

5.10.2 Connect short hose to the other end of the "T" fitting.

45° End of Short Hose (2-1230)

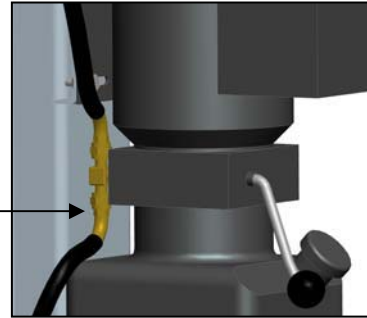

5.10.3 Remove the plastic cap from the bottom of the power side cylinder and connect the short hose to the cylinder.

90° End of Hose

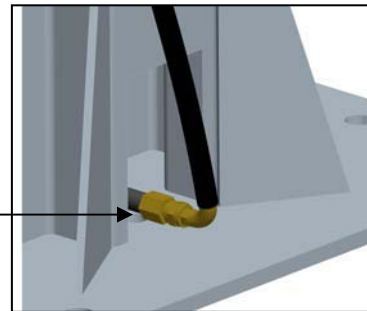

5.10.4

Loop the hydraulic hose up the power side tower, across the overhead and down the slave side tower.



5.10.5 Remove the plastic cap from the bottom of the slave side cylinder and connect the long hose to the cylinder.

90° End of Hose

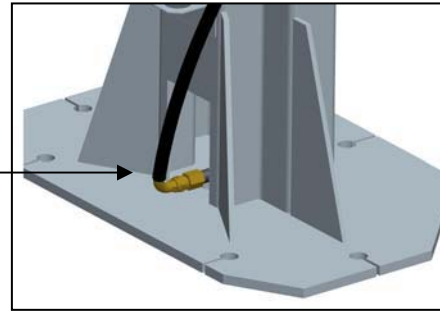

5.10.6

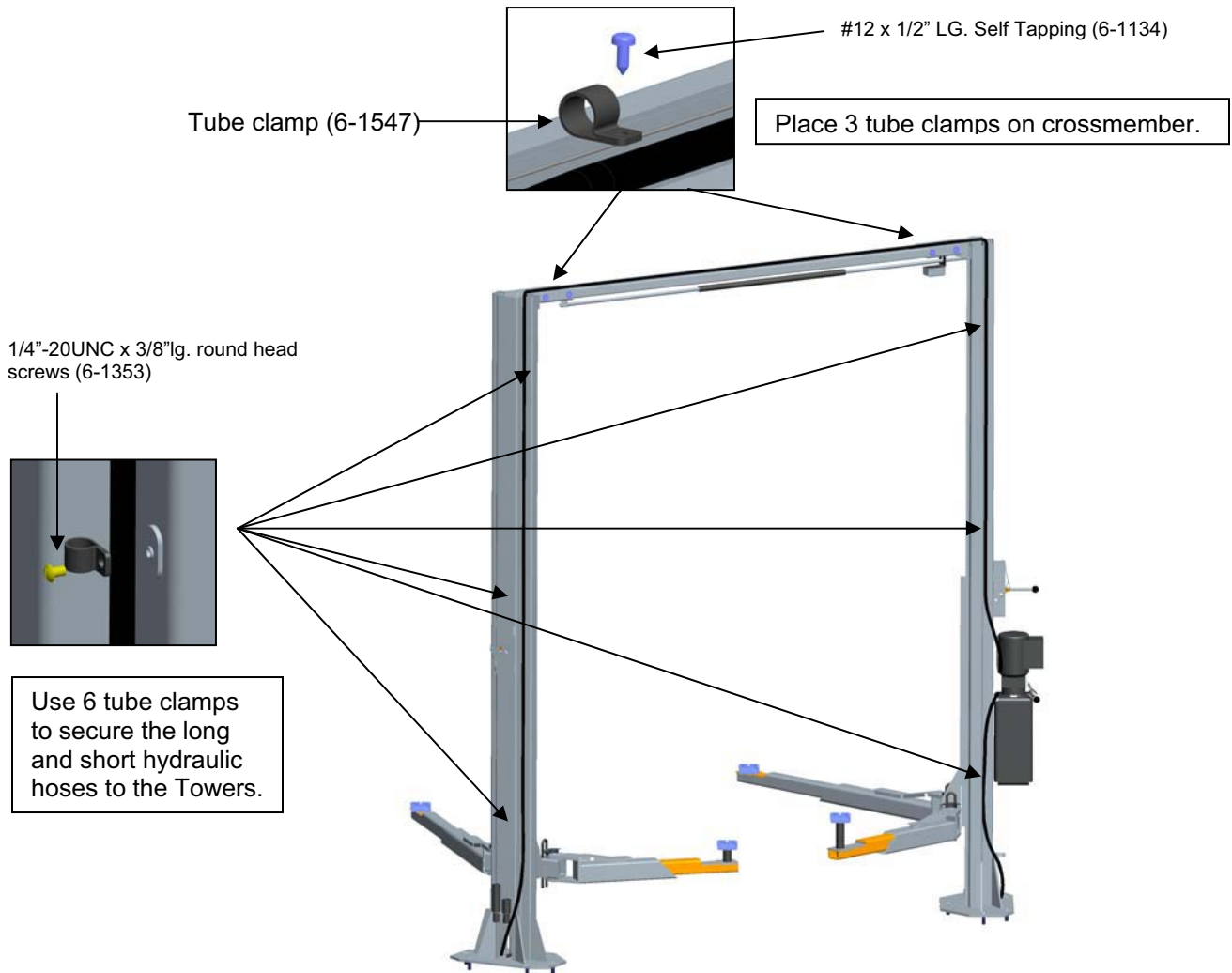

#12 x 1/2" LG. Self Tapping (6-1134)

Tube clamp (6-1547)

Place 3 tube clamps on crossmember.

1/4"-20UNC x 3/8"lg. round head screws (6-1353)

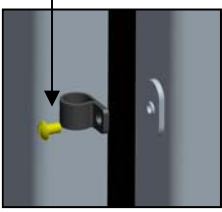

Use 6 tube clamps to secure the long and short hydraulic hoses to the Towers.

5.11 HYDRAULIC SYSTEM BLEEDING

- 5.11.1 Crack the bleeder valve located at the top of both cylinders (approx. $\frac{1}{4}$ turn)

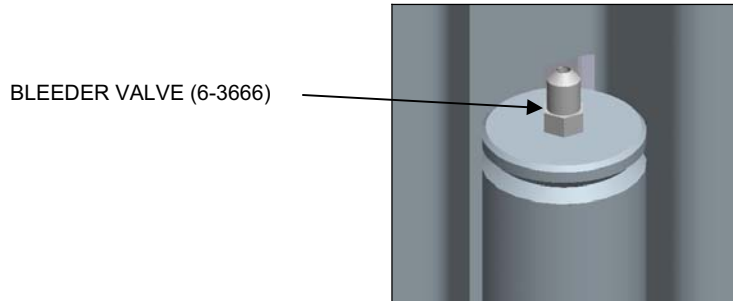

- 5.11.2 Power up 2"-3". You should hear air escaping around the bleeder valve. Repeat 3 – 4 times or until only oil is coming out of the bleeder valve.
- 5.11.3 Tighten the bleed screw and lower the lift.

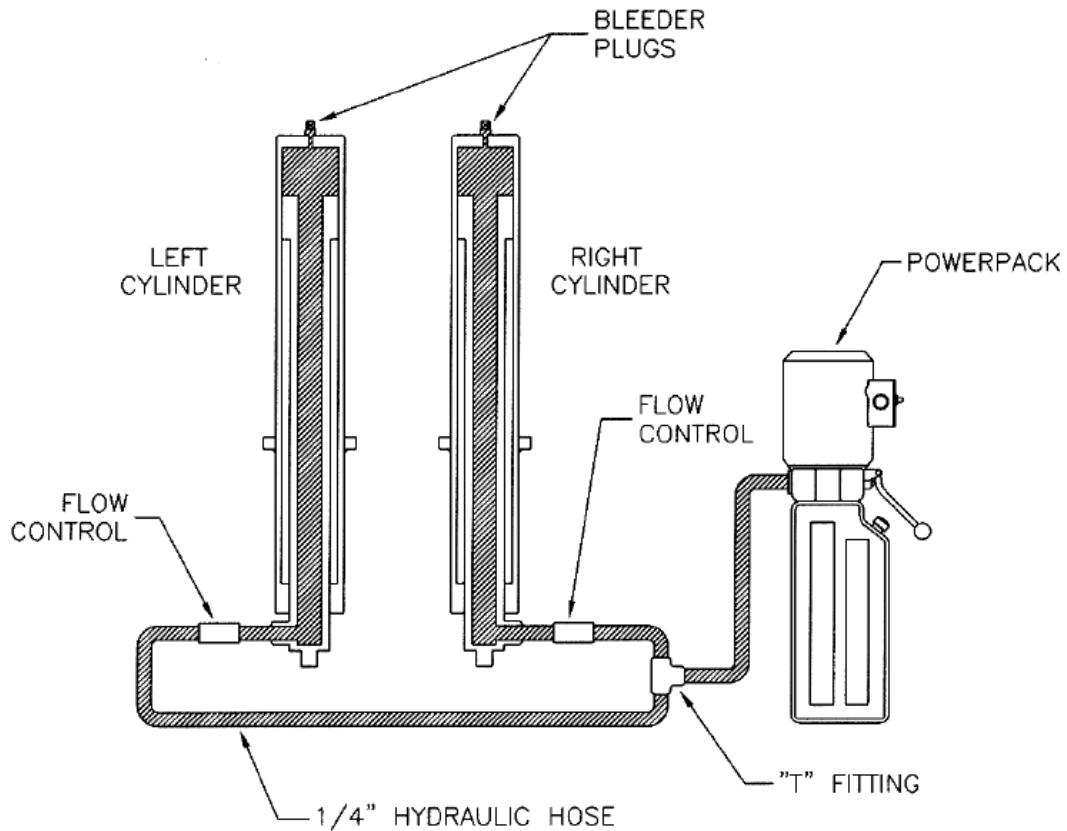

5.12 TOWER POSITIONING AND ANCHORING

WARNING! Failure to follow these instructions may cause an unsafe operating condition.

WARNING! Before proceeding with installation, review Section 4: Installation & Tools.

5.12.1 Determine which column is higher using a 4ft level.

Place 4 ft. Level.

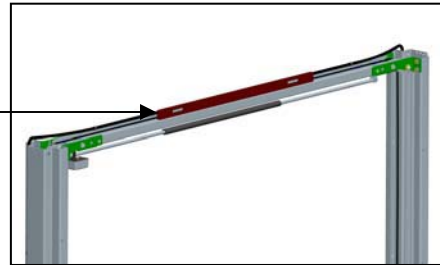

5.12.2 Check if high column is level in the vertical position.

Place 2 ft. Level.

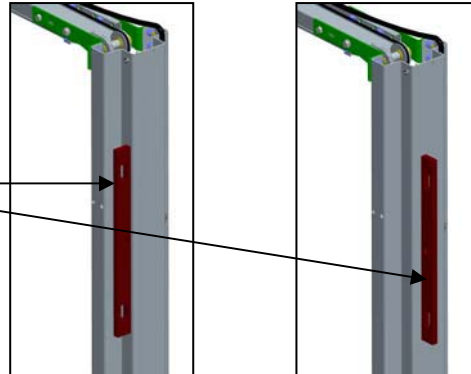

Note: Use shims under baseplate to level the column.

Ensure that the base plate is completely supported by shims including near the center where it does not contact the floor.

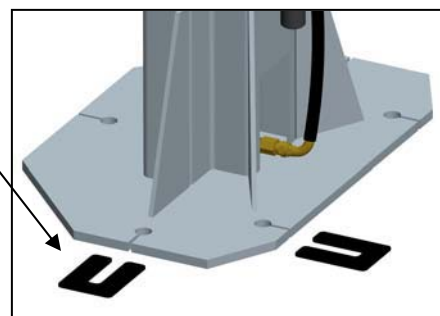
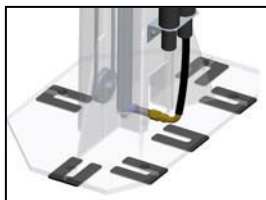

5.12.3 Refer to Bay Layout to ensure that the column is still in the proper position.

5.12.4 Prior to installing anchors, assemble the nut and washer onto anchors. A minimum of six threads must be visible below the surface of the nut. Refer to the figure below while reading through the following instructions.

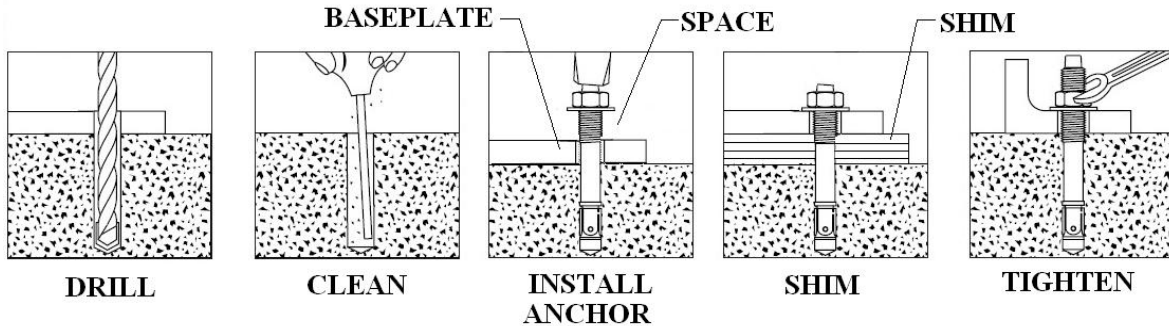

5.12.5 Using a $\frac{3}{4}$ " concrete drill bit and rotary hammer drill, drill $\frac{3}{4}$ " holes for the anchor bolts on the high side column. Drill through the concrete floor. (In case longer anchors are required, supplied anchors can be hammered through concrete).

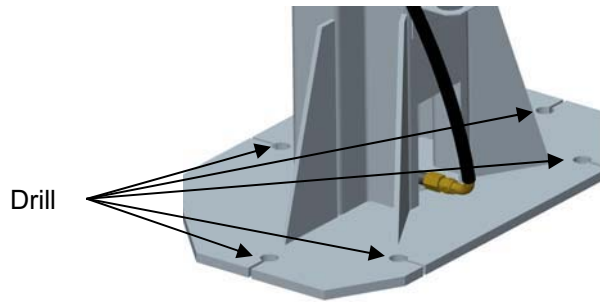

5.12.6 Clean out the drilling dust from the holes and hammer in the anchors until they make contact with the baseplate. **Hand tighten all anchor bolts.**

Check that the column is level front to rear and side to side. Adjust shims as required.

5.12.7 **Torque all anchor bolts to 150 ft-lbs. (203 Nm)**, continually checking that the column is level as you proceed.

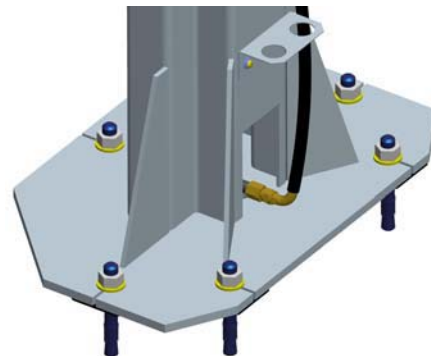

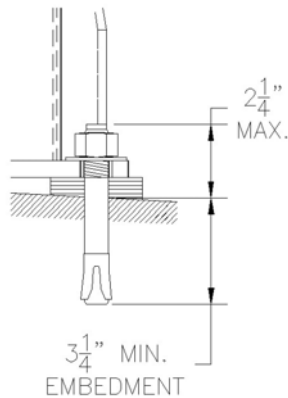

NOTE:

The 3/4" × 5 1/2" lg. wedge anchor bolts supplied must have a minimum embedment of 3 1/4" into concrete floor.

If anchor bolts do not tighten to 150 ft-lbs. OR project more than 2 1/4" above the concrete surface due to floor slope, the concrete should be replaced by an appropriate concrete pad. (Consult Product Manufacturer / Supplier for further details).

5.13 POSITION AND ANCHORING OF REMAINING TOWER

5.13.1 Level the low side column by shim underneath the baseplate.

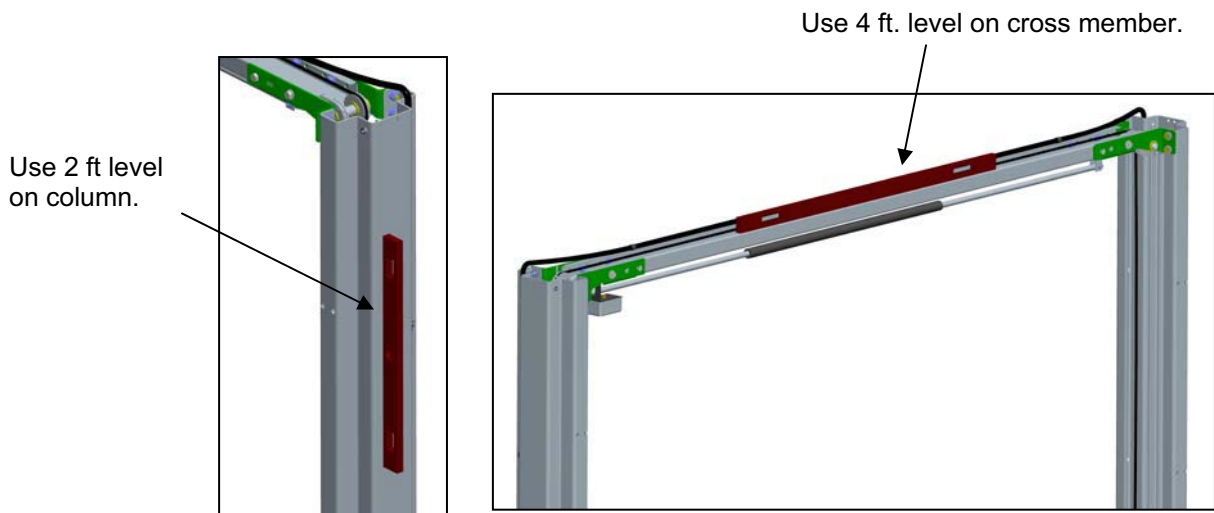

Ensure that the baseplate is completely supported by shims where it does not contact the floor.

- 5.13.2 Refer to Bay Layout to ensure that the column is still in the proper position.
- 5.13.3 Prior to installing anchors, assemble the nut and washer onto anchors. A minimum of six threads must be visible below the surface of the nut. Refer to the figure below while reading through the following instructions.

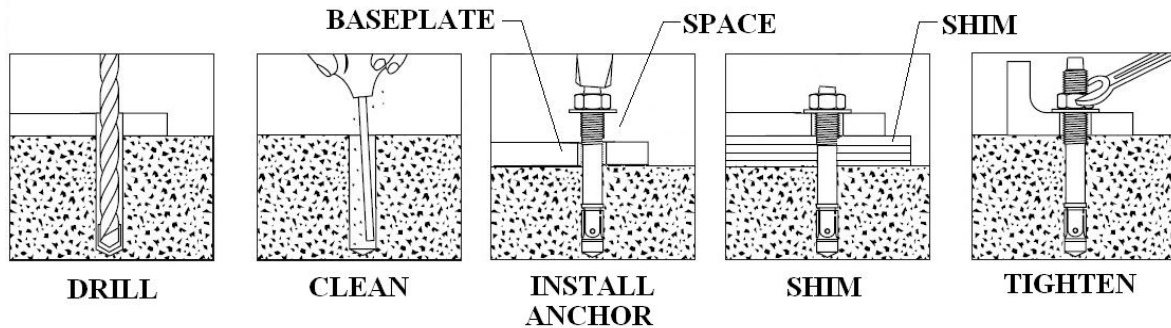

- 5.13.4 Using a $\frac{3}{4}$ " concrete drill bit and rotary hammer drill, drill $\frac{3}{4}$ " holes for the anchor bolts on the high side column. Drill through the concrete floor. (In case longer anchors are required, supplied anchors can be hammered through concrete).

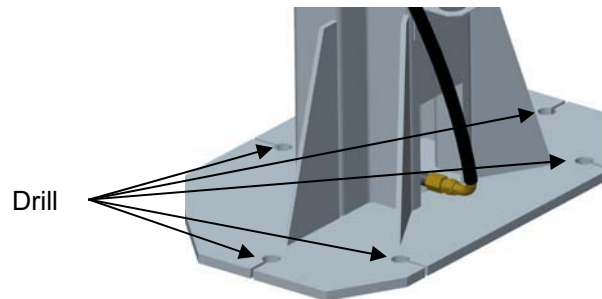

- 5.13.5 Clean out the drilling dust from the holes and hammer in the anchors until they make contact with the baseplate. **Hand tighten all anchor bolts.**

Check that the column is level front to rear and side to side. Adjust shims as required.

- 5.13.6 **Torque all anchor bolts to 150 ft-lbs. (203 Nm)**, continually checking that the column is level as you proceed.

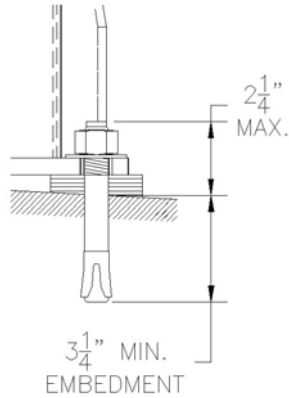

NOTE:

The 3/4" × 5 1/2" lg. wedge anchor bolts supplied must have a minimum embedment of 3 1/4" into concrete floor.

If anchor bolts do not tighten to 150 ft-lbs. OR project more than 2 1/4" above the concrete surface due to floor slope, the concrete should be replaced by an appropriate concrete pad. (Consult Product Manufacturer / Supplier for further details).

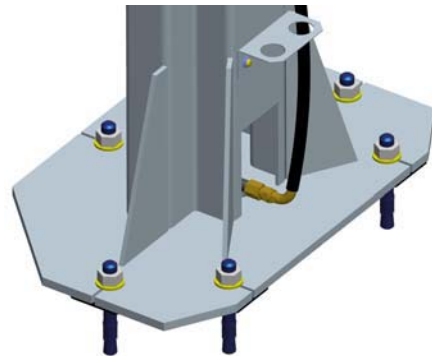

5.13.5 Verify that the entire lift is level both horizontally and vertically to ensure optimum lifting performance. **NOTE: Perform a monthly inspection and torque all anchor bolts to 150 ft-lbs. (203 Nm).**

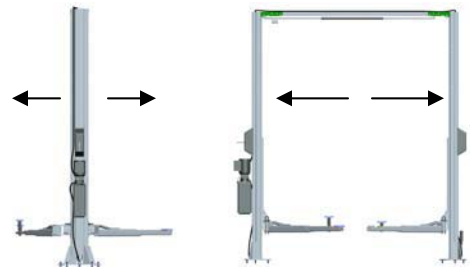

5.14 SAFETY SHUT-OFF BAR ADJUSTMENT

5.14.1 When the lift is fully installed, leveled and operational, extend the carriages to their full upper limit.



5.14.2 Lower the carriages about 1/4" to 1/2".

5.14.3 Attach a 1/4 bolt and nut to actuator extension.

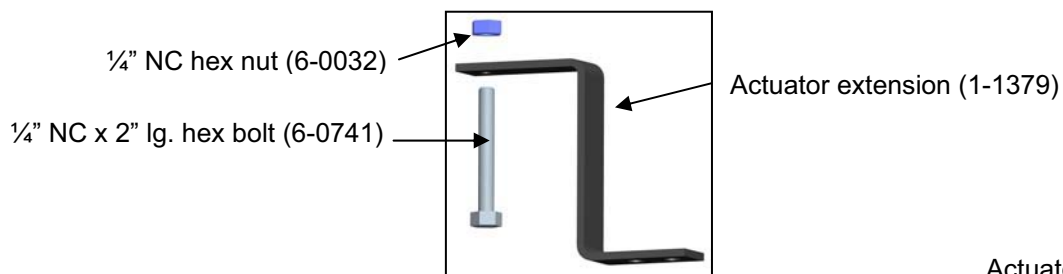

5.14.4 Bolt the Actuator Extension onto the open end of actuator bar.

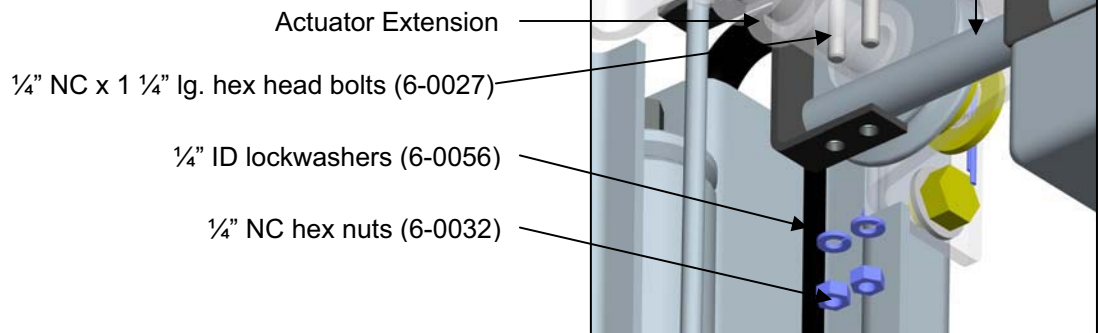

5.14.5 Adjust the 1/4" NC x 2" lg. hex bolt so that the end of the bolt is in contact with the carriage. Tighten the 1/4" NC hex nut on the bolt.

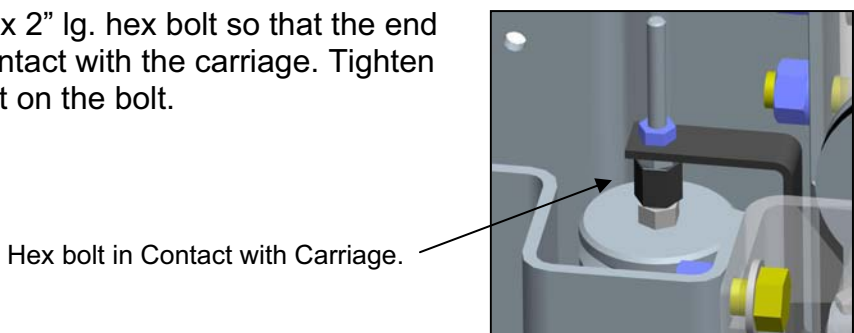

5.15 FINAL CHECK OF ASSEMBLED LIFT

1. Final dimension check after anchoring. _____
2. Check for hydraulic leaks. _____
3. Ensure cables are properly routed and free from obstructions. _____
4. Check jam nuts on cables are tightened. _____
5. Check that LOCTITE has been applied to all hardware where required. _____
6. Check adjustment of safety release cable to ensure both sides working properly. _____
7. Re-check level of towers. _____
8. Check torque of anchor bolts. _____
9. Check all fasteners, tighten if necessary. _____
10. Check shut off at top of stroke to ensure lift shuts off. _____
11. Check proper operation of arm restraints. _____
12. Operate lift to full stroke then lower to ground while checking for proper functionality. _____
13. Ensure Customer Care Kit is complete and given to operator. _____
 - a. Operation Manual _____
 - b. ANSI / ALI Lift It Right Manual _____
 - c. ANSI / ALI Safety Tip Card _____
 - d. ANSI / ALI ALIS Safety Requirements for Installation and Service of Automotive Lifts _____
 - e. ANSI / ALI Quick Reference Guide _____
14. Train end user on operation of lift. _____

5.16 OPERATION TEST WITH VEHICLE

1. Lower lift to ground.
2. Drive vehicle on to lift and locate the arms as per the "Lift it Right" manual.
3. Raise lift to and lower onto 3-4 lock positions during full rise to ensure all locks are working correctly.
4. Re-adjust cables if necessary while vehicle is on.
5. Check lowering speed and smooth decent rate.
6. Lower lift to ground and drive vehicle off lift.

If any problems occur during the final checkout or operation of the lift please contact customer service at 1-800-268-7959

6.0 LIFT MAINTENANCE GUIDELINES

6.1 SAFETY INSTRUCTIONS

Read operating and safety manuals before using any lift.
Do not operate a lift that has been damaged or is in disrepair.
Proper inspection and maintenance is necessary for safe operation.

6.2 PERIODIC MAINTENANCE

DAILY:

1. Check all hydraulic lines and fittings for pinch points , damage , cracks or leaks
2. Check all electrical wiring for pinch points , cracks or damage
3. Check all moving parts for uneven or excessive wear
4. Repair or replace all damaged, defective, worn or broken components immediately.
5. Check the telescopic arms for movement. Clean any grease or oil from the lifting adapters.
6. Raise and lower the lift at the beginning of each shift, without a vehicle on, to verify the lift is leveled and operating properly.

EVERY TWO MONTHS:

1. Clean and re-grease slide block channels inside of both columns
2. Grease arm pins
3. Lubricate safety dogs and check safety release cable adjustment
4. Check arm restraints and lubricate
5. Check anchor bolts and re-torque if required

EVERY FOUR MONTHS:

1. Dismantle and clean inner arms
2. Lubricate cable pulleys
3. Check equalizing cable adjustment

EVERY YEAR:

1. Inspect lift as per Automotive Lift Operation, Inspection and Maintenance (ALOIM)

EVERY TWO YEARS:

1. Change hydraulic fluid

LUBRICATION:

Where grease is required > multi-purpose lithium grease

Where lubricating oil is required > multi-purpose SAE 30 lubricating oil

Where hydraulic oil is required > ISO 32 10W - non detergent hydraulic oil

NOTE: If the lift locks, while in the fully raised position this will indicate that the hydraulic system has not been inspected or maintained as recommended. This is a safety back-up system. If you are unclear call your local representative immediately.

7.0 SAFETY AWARENESS

AUTOMOTIVE LIFT INSTITUTE (ALI)

Automotive Lift Institute, Inc
WL101 Series
Label Kit

SAFETY INSTRUCTIONS	SAFETY INSTRUCTIONS
Read operating and safety manuals before using lift.	Proper maintenance and inspection is necessary for safe operation.
SAFETY INSTRUCTIONS	<p>The messages and pictographs shown are generic in nature and are meant to generally represent hazards common to all automotive lifts regardless of specific style.</p> <p>Funding for the development and validation of these labels was provided by the Automotive Lift Institute, PO Box 85 Cortland, NY 13045.</p> <p>Replacement label sets may be obtained from the original lift manufacturer and ALI's member companies. They are protected by copyright.</p> <p>www.autolift.org © 1992 by ALI, Inc. ALI/WL101</p>
Do not operate a damaged lift.	

CAUTION	CAUTION	WARNING	WARNING
Lift to be used by trained operator only.	Authorized personnel only in lift area.	Clear area if vehicle is in danger of falling.	Position vehicle with center of gravity midway between adapters.
CAUTION	CAUTION	WARNING	WARNING
Use vehicle manufacturer's lift points.	Always use safety stands when removing or installing heavy components.	Remain clear of lift when raising or lowering vehicle.	Avoid excessive rocking of vehicle while on lift.
CAUTION	CAUTION	WARNING	WARNING
Use height extenders when necessary to ensure good contact.	Auxiliary adapters may reduce load capacity.	Do not override self-closing lift controls.	Keep feet clear of lift while lowering.
<p>The messages and pictographs shown are generic in nature and are meant to generally represent hazards common to all automotive lifts regardless of specific style.</p> <p>Funding for the development and validation of these labels was provided by the Automotive Lift Institute, PO Box 85 Cortland, NY 13045.</p> <p>Replacement label sets may be obtained from the original lift manufacturer and ALI's member companies. They are protected by copyright.</p>		<p>The messages and pictographs shown are generic in nature and are meant to generally represent hazards common to all automotive lifts regardless of specific style.</p> <p>Funding for the development and validation of these labels was provided by the Automotive Lift Institute, PO Box 85 Cortland, NY 13045.</p> <p>Replacement label sets may be obtained from the original lift manufacturer and ALI's member companies. They are protected by copyright.</p>	

8.0 PARTS LIST

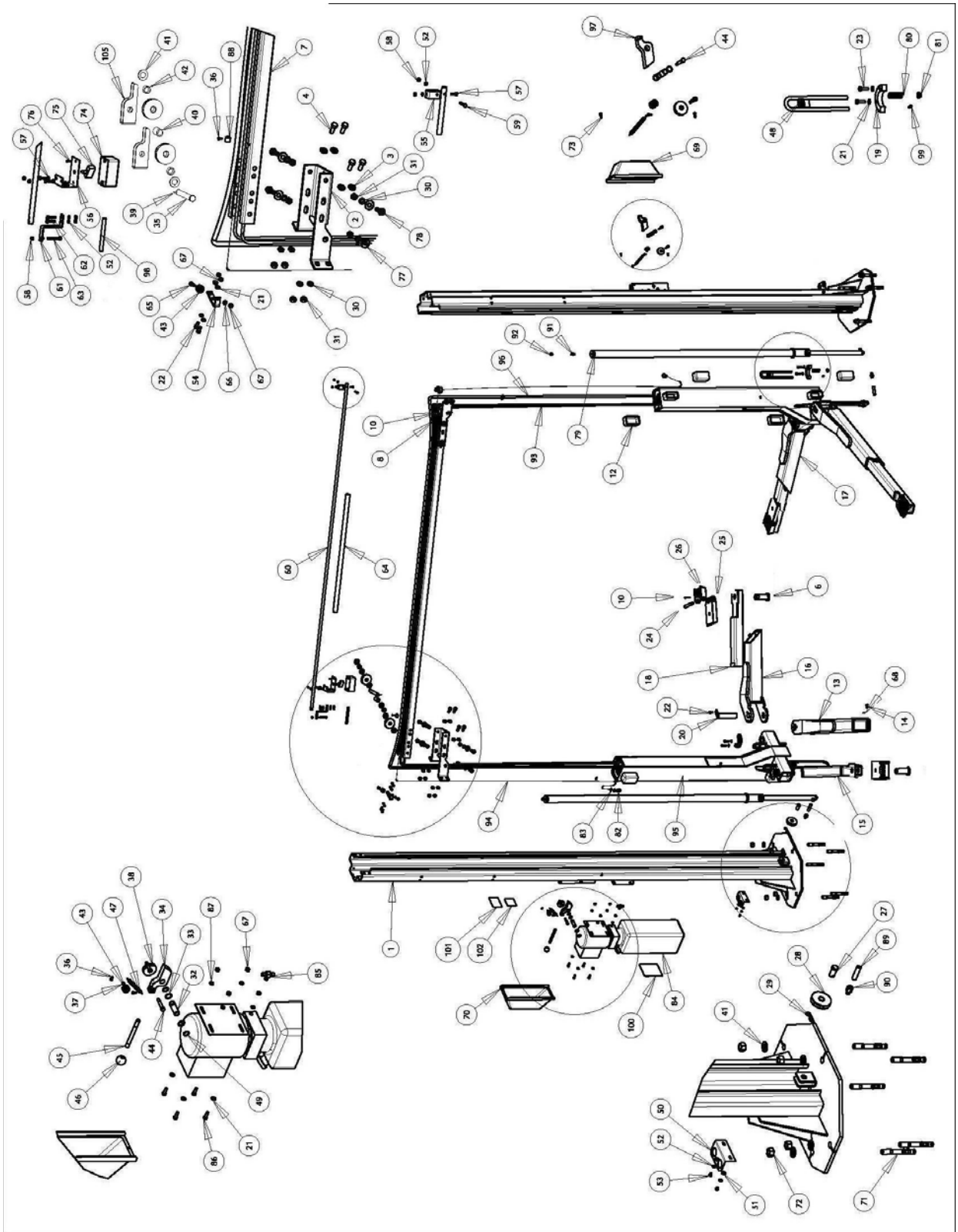

Item#	Part #	Description	Qty.
1	4-1010	TOWER WELDMENT	2
2	3-0949	ASYMMETRIC BRACKET LS	1
3	6-0248	Flat Washer, 1/2" ID SAE	8
4	6-0291	Hex Bolt, 1/2"-13 UNC x 1 1/2" LG.	8
5	1-3106	Pulley Bracket Spacer	2
6	1-3276	Adapter Pin	4
7	2-2323	CROSSMEMBER	1
8	3-0950	ASYMMETRIC BRACKET RS	1
10	6-0267	Cotter Pin 1/8" Dia x 1" Lg	4
11	4-1163	CARRIAGE WELDMENT	2
12	2-0772	SLIDER BLOCK	8
13	3-0979	OUTER ARM WELDMENT - LONG	2
14	6-0030	Hex Bolt, 3/8 UNC x 3/4" LG.	2
15	3-0980	ASYM LONG INNER	2
16	3-0981	Outer Arm Weldment (L.S.)	1
17	3-0982	Outer Arm Weldment (R.S.)	1
18	3-0983	Inner Arm Weldment (Short)	2
19	1-2618	ARM RESTRAINT GEAR	4
20	2-1594	ARM PIN	4
21	6-0295	Flat Washer, 5/16" I.D.	16
22	6-0423	Hex Bolt, 5/16"- 18UNC x 3/4" LG.	8
23	6-2059	Hex HD. Bolt, 5/16"-18UNC x 1 1/4" LG.	8
24	1-1099	Center Pin	4
25	3-0582	High Position Adapter	4
26	3-0583	Low Position Adapter	2
27	1-1887	HEADED PIN	2
28	1-1898	PULLEY ASSEMBLY	6
29	6-1841	Hitch Pin, 1/8" DIA.	2
30	6-0059	Lock Washer, 1/2"	16
31	6-0035	NUT, 1/2-13 UNC, HEX	16
32	1-2337	SAFETY LOCK PIN	2
33	6-0808	3/4 FLAT WASHER	4
34	2-1901	Safety Dog Weldment, Power Side	1
35	1-3176	Pulley Pin	2
36	6-1134	SELF-TAPPING SCREW, #12 X 1/2" LG	3
37	6-0206	Shoulder Bolt, 3/8" DIA. X 1" LG.	3
38	1-0415	SAFETY CABLE PULLEY	2
39	6-0978	Cotter Pin, 1/8" DIA. X 1 1/2" LG.	2
40	1-1626	Crossmember Pulley Pipe, 1 3/4" LG.	2
41	6-0738	Flat Washer, 3/4" ID	22
42	1-1623	Crossmember Pulley Pipe, 1/2" LG.	4
43	1-1116	SAFETY CABLE PULLEY	3
44	6-0801	Shoulder Bolt, 3/8" x 1 1/2" LG.	2
45	1-1113	Safety Release Handle	1
46	6-1135	Plastic Knob	2
47	1-1115	SAFETY SPRING	2
48	1-2914	ARM LOCK HANDLE WELDMENT	4
49	6-2445	Snap Ring 3/4" EXT	4
50	1-2012	Stack Pad Adapter Holder	2
51	6-0060	Flat Washer, 1/4" I.D.	4
52	6-0056	Lock Washer, 1/4" I.D.	10
53	6-1353	Round HD. MACH. Screw 1/4"-20 x 3/8" LG.	10
54	2-1477	Safety Cable Pulley Bracket	2
55	1-1378	Actuator Mounting Bracket	1

56	2-1143	Limit Switch Mounting Bracket	1
57	6-0178	Hex Bolt, 1/4" x 3/4" LG.	1
58	6-0032	Hex Nut, 1/4"-20UNC	7
59	6-0205	Hex HD. Bolt 1/4" NC x 1 1/2" LG.	1
60	1-1380	ACTUATOR BAR	1
61	1-1379	Actuator Extension	1
62	6-0027	Hex HD. Bolt 1/4"NC x 1 1/4" LG.	2
63	6-0741	Hex HD. Bolt 1/4"NC x 2" LG.	1
64	6-1404	Foam Guard	1
65	6-0069	Shoulder Bolt, 3/8" DIA. X 5/8" LG.	2
66	6-0296	5/16" Lock Washer	6
67	6-0294	Hex Nut, 5/16"-18UNC	10
68	6-0062	Flat Washer, 3/8" ID SAE	2
69	0-0203	Safety Cover c/w Decals, Slave Side	1
70	0-0204	Safety Cover c/w Decals, Power Side	1
71	6-1379	Wedge Anchor 3/4" x 5 1/2" LG. (c/w Washers & Nuts)	10
72	6-0737	Hex Nut, 3/4"-10UNC	10
73	6-1134	SELF TAPPING SCREW, #12 X 1/2" LG	4
74	6-1403	Electrical Utility Box	1
75	6-0916	Microswitch	1
76	6-1466	6/32 Screw (Electrical Box)	2
77	6-0248	Flat Washer, 1/2"	8
78	6-0045	Hex Bolt, 1/2"-13UNC X 1" LG.	8
79	3-0621	Hydraulic Cylinder Assembly	2
80	1-2942	HANDLE SPRING	1
81	6-3086	Spring Retainer Cap	1
82	6-2074	Thimble, 5/32"	2
83	6-2060	Wire Rope Clip, 1/16"	2
84	6-2055	Power Pack, 208-230 V, 1 PH	1
85	6-1506	Branch Tee	1
86	6-0293	Hex Bolt, 5/16"-18UNC x 1" LG.	4
87	6-0674	Lock Washer, 5/16" I.D.	4
88	6-1547	Tube Clamp, 5/8"	8
89	6-2095	Male Nipple, 1/4" NPT	2
90	6-1510	Flow Control	2
91	6-0280	1/8" NPT to 1/4" NPT	2
92	6-1884	1/4" JIC Cap	2
93	1-1786	Equalizing Cables	2
94	1-2058	Safety Release Cable	1
95	2-1230	Hydraulic Hose (Long)	1
96	2-1486	Hydraulic Hose (Short)	1
97	2-0872	Safety Dog, Slave Side	1
98	6-1173	Elec. Cable 12/3 x 117" LG.	1
99	6-0000	Grease Nipple	4
100	6-2094	Operational Decal	1
101	6-1767	Capacity Decal	1
102	6-1111	Serial Number Plate	1
103	6-0008	Hex Bolt, 1/4" x 1" LG.	2
104	6-1134	SELF TAPPING SCREW, #12x1/2" LG	3
105	1-3483	Cable Retainer	4

8.1 HYDRAULIC SYSTEM

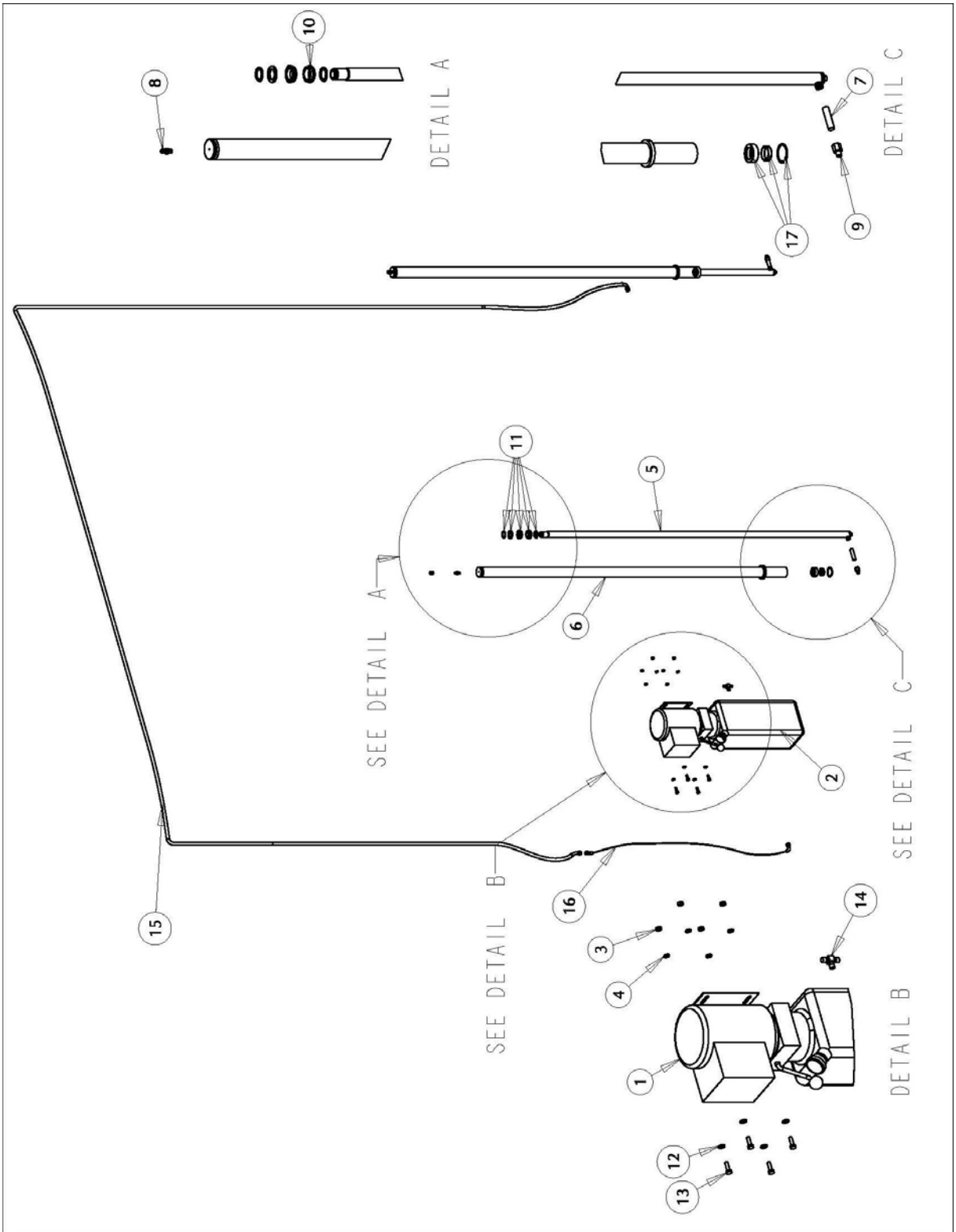





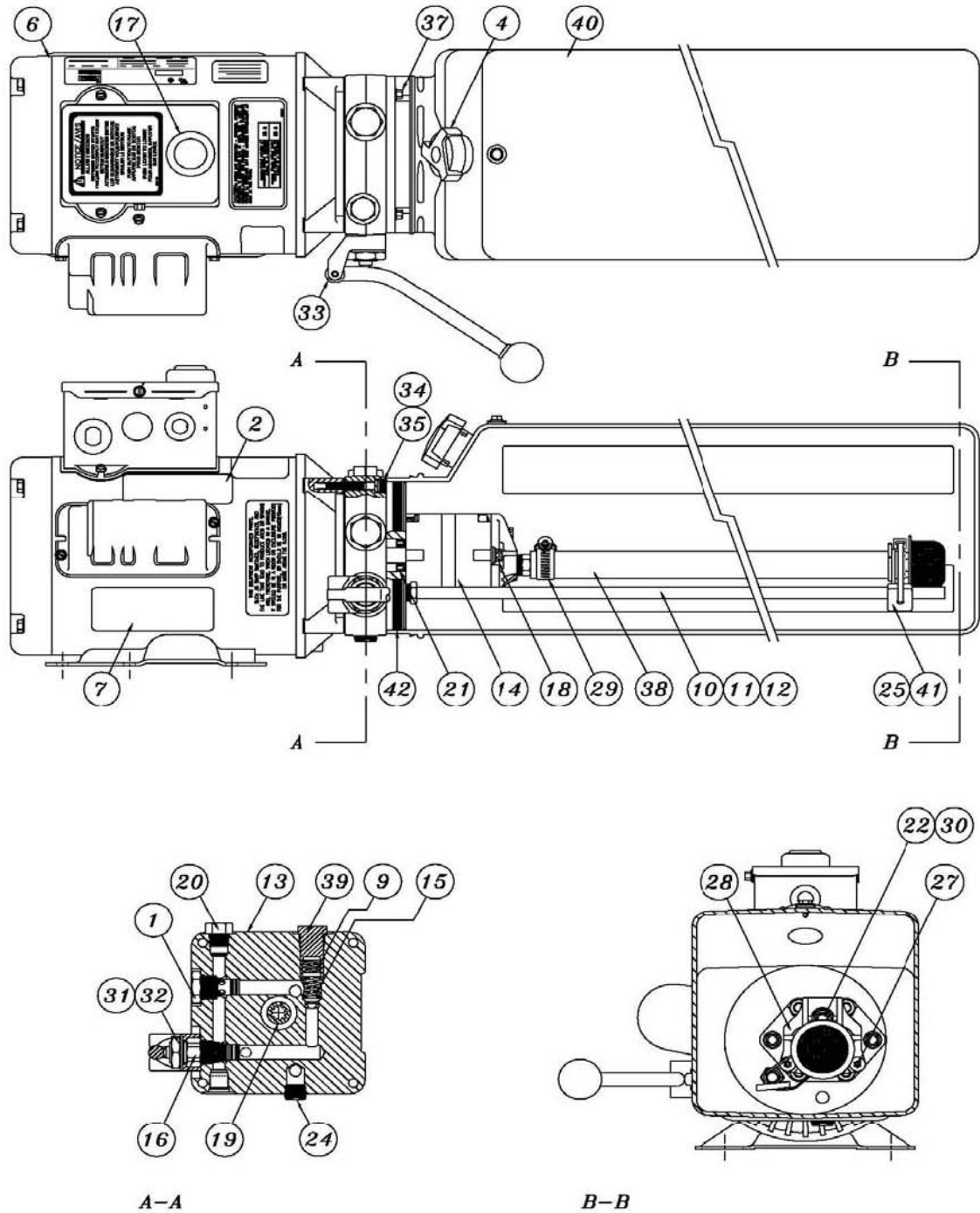





Item	Part #	Description	Qty
1	6-2055	Power Pack, 208-230V, 1 PH	1
	6-2665	Power Pack, 208-230V, 3 PH	
2	6-2094	"Lift Operation" Decal	1
3	6-0294	Hex Nut, 5/16"-18 UNC	4
4	6-0674	Lock Washer, 5/16" I.D.	4
5	2-1254	Piston Rod	2
6	2-125501	Cylinder Tube	2
7	6-2095	Male Nipple, 1/4" NPT	2
8	6-3666	Bleeder Valve	2
9	6-1510	Flow Control	2
10	1-1467	Piston	2
11	0-0337	Piston Seal Kit	2
12	6-0295	Flat Washer, 5/16" I.D.	4
13	6-0293	Hex Bolt, 5/16"-18 UNC x 1" LG.	4
14	6-1506	Branch Tee	1
15	2-1496	Hydraulic Hose (Long)	1
16	2-1230	Hydraulic Hose (Short)	1
17	6-3162	Gland & Piston Seal Kit	2
	3-062101	Cylinder Assembly (Not INCL. Flow Control)	*
		3PH Power Pack Includes the Following (<i>Not Shown</i>)	
*	6-1575	Contactor Box	1
*	2-1130	Contactor Bracket	1
*	1-1369	Cover Plate	1
*	6-0008	Hex Bolt, 1/4" -NC x 1" LG	2
*	6-0056	Lock Washer, 1/4"	4
*	6-0032	Hex Nut, 1/4" - NC	2
*	6-0094	Strain Relief	2
*	8-0287	Cable, 14/4	2 ft.

8.2 POWERPACK PARTS LIST

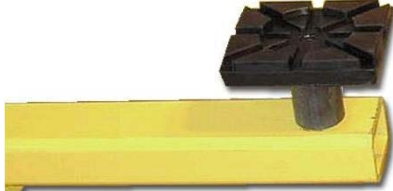
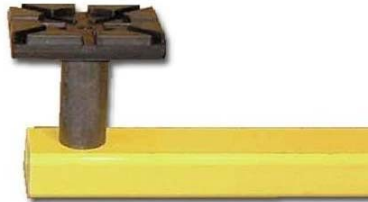

Item	Part #	Description	Qty
1	6-1087	Valve Cartridge Check	1
2	6-2136	Label Installation Autohoist	1
4	6-1376	Breather Cap & Bladder	1
6	6-2474	Motor AC 208-230V. 2HP/1PH/60Hz, BLK	1
7	6-2149	Label Warning Autohoist	1
9	6-2151	Spring 0.480" x 0.063" x 0.42" Comp	1
10	6-2152	Return Hose 3/8" OD x 21.5"	1
11	6-2153	Compression Tube Nut	1
12	6-2154	Compression Tube Sleeve	1
13	6-2155	Endhead Universal Autohoist	1
14	6-1958	Pump Assy 2.5 CC / Rev. Short Spline	1
15	6-1319	Relief Assembly Fixed 190 Bar	1
16	6-0880	Valve Cartridge Release Manual	1
17	6-2473	Wiring Assembly AC 1PH Fenner	1
18	6-1090	Bolt 5/16"-24 x 3.00 TORX G8	2
19	6-0774	Coupling SAE 9T-20/40 1.260"	1
20	6-2157	Plumbing Plug 9/16" SAE	1
21	6-2158	Seal Shaft 0.500" x 1.00" x 0.25"	1
22	6-2159	Washer 0.338" x 0.625" x 0.060" Steel	1
24	6-2161	Plumbing Plug 3/8" NPT	1
25	6-2162	Plumbing Magnet	1
27	6-2164	Screw Taptite M6 x 1.0 12MM TORX	2
28	6-2165	Cover Assy Suction	1
29	6-2166	Plumbing Clamp Hose Adj. Inlet	1
30	6-1392	Bolt 5/16"-18 x 1.00" SHCS	1
31	6-2167	Nut 3/4"-16 x 1" HEX x 0.250" Steel	1
32	6-2168	Washer 3/4" Int. Tooth Lock	1
33	6-0776	Bracket – Handle Assy Rel Black	1
34	6-2169	Bolt M6 x 1.0 35mm SOC HD	4
35	6-2170	Washer 1/4" Lock Hi-Collar	4
37	6-1091	Bolt #12-24 x 0.50" Hex WSHRHD	4
38	6-0786	Plumbing Assy Inlet 17.24 (3)	1
39	6-1089	Relief Valve Cap Assembly	1
40	6-1399	Tank Plastic 6.7 OS 22.50" BLK	1
41	6-1846	Cable Tie 8" Long White	1
42	6-0875	O-Ring 2-348 Buna	1

9.0 AVAILABLE ACCESSORIES

Flip Pad Accessories				
	Poly Pad Adapter (set of 4)		High Lift Truck Extension Mid-Rise / 2-Post (set of 2)	
3000 lb max capacity each		2500 lb max capacity each		
Stack Pad Accessories				
	Stack Pad Adapter w/ Checker Plate Top (set of 4)		Stack Pad Ass'y w/ 3" & 6" Adapters (set of 1)	
3000 lb max capacity each		3000 lb max capacity each		
	1 1/2" Stack Pad Assembly Kit		4 1/2" Stack Adapter Kit	
3000 lb max capacity each		3000 lb max capacity each		
Common Accessories				
	Tool Tray Kit for 2-Post		Secondary Adapter Pad Kit (Used On Outer Arms)	
		3000 lb max capacity each		
	Air / Electric Service Station for 2-Post & 4-Post (90-110 psi 110 Volts Required)		Foam Door Protector Kit	
				24" Tower Extension

Accessories may not be available for all models. Contact supplier for availability and part numbers.

Max capacity is for 12,000 Lb Lifts. Do not exceed rated capacity of lift.