



INSTALLATION and OPERATION MANUAL



10K ALL IN ONE 2 POST 1969SA / 1969SA14

**READ THIS INSTRUCTION MANUAL THOROUGHLY
BEFORE INSTALLING, OPERATING, SERVICING OR
MAINTAINING THE LIFT.**



6500 Millcreek Drive
Mississauga, Ontario
Canada, L5N-2W6
1-800-268-7959

SAVE THIS MANUAL.

JAN 09 REV.- 6-2663

Table of Contents

1.0 SAFETY AND OPERATING INSTRUCTIONS	3
2.0 SPECIFICATIONS.....	5
3.0 PACKING LIST.....	6
4.0 INSTALLATION REQUIREMENTS AND TOOLS.....	7
4.1 FOUNDATION	7
4.2 TOOLS.....	7
5.0 INSTALLATION INSTRUCTIONS.....	8
5.1 UNPACKING PROCEDURE.....	8
5.2 BAY LAYOUT.....	9
5.3 CROSSMEMBER INSTALLATION	10
5.4 SAFETY SHUT-OFF BAR INSTALLATION	11
5.5 ROUTING OF EQUALIZATION CABLE.....	13
5.6 ARM INSTALLATION.....	16
5.7 ARM RESTRAINT INSTALLATION	17
5.8 SAFETY RELEASE CABLE ROUTING AND ADJUSTMENT	18
5.9 POWER PACK INSTALLATION	20
5.10 HYDRAULIC SYSTEM INSTALLATION	21
5.11 HYDRAULIC SYSTEM BLEEDING	24
5.12 TOWER POSITIONING AND ANCHORING.....	25
5.13 POSITION AND ANCHORING OF REMAINING TOWER.....	27
5.14 SAFETY SHUT-OFF BAR ADJUSTMENT	30
5.15 FINAL CHECK OF ASSEMBLED LIFT	31
5.16 OPERATION TEST WITH VEHICLE	32
6.0 LIFT MAINTENANCE GUIDELINES	33
6.1 SAFETY INSTRUCTIONS	33
6.2 PERIODIC MAINTENANCE	33
7.0 SAFETY AWARENESS	34
8.0 PARTS LIST	35
8.1 HYDRAULIC SYSTEM	41
8.2 POWER PACK PARTS LIST:	43
9.0 Available Accessories	47

1.0 SAFETY AND OPERATING INSTRUCTIONS

1. When using this lift, basic safety precautions should always be followed, including the following.
2. Read all instructions in this manual and on the lift thoroughly before installing, operating, servicing or maintaining the lift.
3. Inspect lift daily. Do not operate if it malfunctions or problems have been encountered.
4. Never attempt to overload the lift. The manufacturer's rated capacity is shown on the identification label on the power side column. Do not override the operating controls or the warranty will be void.
5. Before driving vehicle between the towers, position the arms to the drive-through position to ensure unobstructed clearance. Do not hit or run over arms as this could damage the lift and/or vehicle.
6. Only trained and authorized personnel should operate the lift. Do not allow customers or bystanders to operate the lift or be in the lift area.
7. Position the lift support pads to contact the vehicle manufacturers recommended lifting points. Raise the lift until the pads contact the vehicle. Check pads for secure contact with the vehicle. Check all arm restraints and insure they are properly engaged. Raise the lift to the desired working height.
8. Some pickup trucks may require an optional truck adapter to clear running boards or other accessories.
9. **NOTE:** Always use all 4 arms to raise and support vehicle.
10. **Caution! Never work under the lift unless the mechanical safety locks are engaged.**
11. Note that the removal or installation of some vehicle parts may cause a critical load shift in the center of gravity and may cause the vehicle to become unstable. Refer to the vehicle manufacturer's service manual for recommended procedures.
12. Always keep the lift area free of obstruction and debris. Grease and oil spills should always be cleaned up immediately.
13. Never raise vehicle with passengers inside.
14. Before lowering check area for any obstructions.
15. Before removing the vehicle from the lift area, position the arms to the drivethru position to prevent damage to the lift and or vehicle.
16. Do not remove hydraulic fittings while under pressure.

For additional safety instructions regarding lifting, lift types, warning labels, preparing to lift, vehicle spotting, vehicle lifting, maintaining load stability, emergency procedures, vehicle lowering, lift limitations, lift maintenance, good shop practices, installation, operator training and owner/employer responsibilities, please refer to “Lifting It Right” (ALI/SM) and “Safety Tips” (ALI/ST).

For additional instruction on general requirements for lift operation, please refer to “Automotive Lift-Safety Requirements For Operation, Inspection and Maintenance” (ANSI/ALI ALOIM).

Installation shall be performed in accordance with ANSO/ALI ALIS, Safety Requirements for Installation and Service of Automotive Lifts.



ATTENTION! This lift is intended for indoor installation only. It is prohibited to install this product outdoors. Operating environment temperature range should be 41 – 104 °F (5 – 40 °C). Failure to adhere will result in decertification, loss of warranty, and possible damage to the equipment.

+ 070126-Quadra-WLSIA01

SAFETY INSTRUCTIONS

If attachments, accessories or configuration modifying components that are located in the load path, affect operation of the lift, affect the lift electrical listing or affect intended vehicle accommodation are used on this lift and, if they are not certified for use on this lift, then the certification of this lift shall become null and void. Contact the participant for information pertaining to certified attachments, accessories or configuration modifying components.

www.autolift.org

©2007 by ALI, Inc.

ALI / WLSIA01

2.0 SPECIFICATIONS

Capacity:
 Capacity per arm:
 Overall Width:
 Width Between Columns:
 Drive-Thru Width:
 Overall Height:
 Under bar Clearance:
 Height to Lowered Lift Pads
 Height to Lift Pad (3" Adapter):
 Height to Lift Pad (6" Adapter):
 Front Arm Retracted Length:
 Front Arm Extended Length:
 Rear Arm Retracted Length:
 Rear Arm Extended Length:
 Maximum Lifting Height (6" Adapter):
 Lift Time:
 Power Requirements (Standard):

10000 lbs.	4536 kg
2500 lbs	1134 kg
148"	3759 mm
120"	3048 mm
98 3/4"	2508 mm
144"	3658 mm
140"	3556 mm
4 1/2"	114 mm
7 1/2"	191 mm
10 1/2"	267 mm
22 1/2"	571 mm
45 1/2"	1156 mm
38"	965 mm
59 1/2"	1511 mm
79 1/4"	2013 mm
45 seconds	
230 Volts AC, 1 Ph., 60 Hz. 20 Amps	

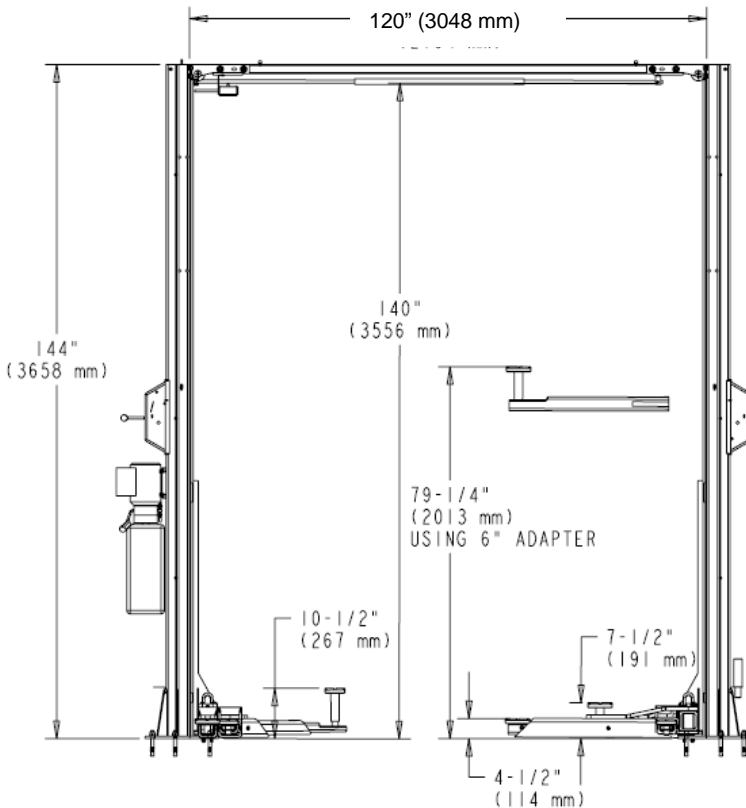

Figure 1 - Front View

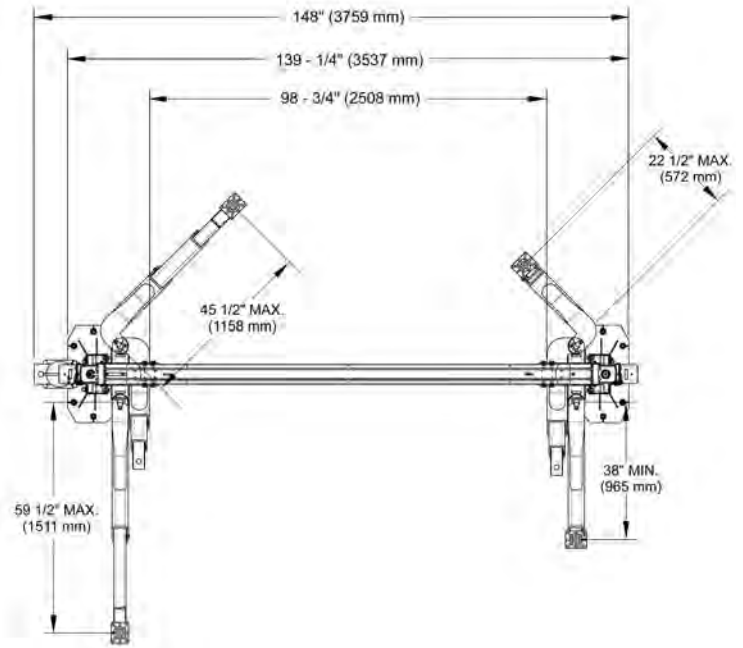

Figure 2 - Top View

3.0 PACKING LIST

The complete lift is contained in two (2) packages:

1. The **main structural components** are packed in a steel frame.
2. The remaining parts are packed in an **accessory box**.

3.1 Main Structural Components

- 1pc. - Power side tower and carriage assembly
- 1pc. - Slave side tower and carriage assembly
- 1pc. - Crossmember
- 1pc. - Actuator Bar w/ foam

3.2 Accessory Box

- 4pcs. - Locking Arm Assembly w/arm pins
- 2pcs. - Safety Covers w/Decals
- 1pc. - Hardware Package w/Packing List
- 1pc. - Actuator Extension
- 1pc. - Actuator Mounting Bracket
- 1pc. - Power Pack
- 4pc. - Arm Restraint
- 1pc. - Safety Release Cable
- 1pc. - Hydraulic Hose (Long)
- 1pc. - Hydraulic Hose (Short)
- 2pcs. - Equalizing Cable w/Hex Nuts
- 1pc. - ALI manual "Lifting It Right"
- 1pc. - Automotive Lift Safety Tips
- 1pc. - Automotive Lift, Operation, Inspection and Maintenance manual
- 1pc. - "ALI" Quick Reference Guide
- 1pc. - Owner's manual
- 1pc. - Safety Shut-off Microswitch Assembly (Components)

4.0 INSTALLATION REQUIREMENTS AND TOOLS

4.1 FOUNDATION

IMPORTANT: It is the user's responsibility to provide a satisfactory installation area for the lift. Lifts should only be installed on level concrete floors with a minimum thickness of four and a quarter inches (4¼") or 108 mm. Concrete must have a minimum strength of 3000 psi or 21 MPa and should be aged thirty (30) days prior to installation. Please consult the architect, contractor or engineer if doubt exists as to the strength and feasibility of the floor to enable proper lift installation and operation.

It is the user's responsibility to provide all wiring for electrical hook-up prior to installation and to insure that the electrical installation conforms to local building codes. Where required, it is the user's responsibility to provide an electrical isolation switch located in close proximity to the lift that will enable emergency stop capability and isolate electrical power from the lift for any servicing requirements.

4.2 TOOLS

- a. 16ft. Measuring Tape
- b. Chalk Line
- c. Rotary Hammer Drill
- d. 3/4" diameter Masonry Drill Bit
- e. Hammer
- f. SAE Wrenches and Ratchet Set
- g. 2ft. Level
- h. 4ft. Level
- i. Crow Bar
- j. 12ft. Step Ladder
- k. Side Cutters
- l. Screwdrivers
- m. 4" x 4" Wooden Blocks (for unpacking)
- n. 4 gal. Hydraulic Fluid
- o. Impact Wrench
- p. Torque Wrench
- n. Wherever LOCTITE symbol is shown, apply LOCTITE #242 on required fasteners. If fasteners are removed reapply LOCTITE before re-installing.



5.0 INSTALLATION INSTRUCTIONS

When the lift arrives on site:

- Read the owner's manual and make sure the installation instructions are fully understood.
- Check for any freight damages.
- Check the contents of the accessory and hardware boxes to make sure no parts are missing.
- Gather all the tools listed above.

5.1 UNPACKING PROCEDURE

5.1.1 Important! Place the main structural components on wooden blocks so that the steel shipping frames can be removed.

5.1.2 Remove the plastic wrapping.

5.1.3 Remove the crossmember, and the actuator bar.

5.1.4 Unbolt the steel shipping frames.

5.1.5 Lay each tower on the floor with the carriage side up.

5.1.6 Check the installation area for obstructions. (Lights, Heating Ducts, Ceiling, Floor Drains, etc.)

5.2 BAY LAYOUT

- 5.2.1 Prepare the bay by selecting the location of the lift relative to the walls.
- 5.2.2 Clear the installation area of all packaging materials to avoid trip hazards.
- 5.2.3 Measure midpoint of door.
- 5.2.4 Using measuring tape scribe two arcs, equal distance from the midpoint.
- 5.2.5 The centerline of the lift occurs between the intersection of the arcs and the midpoint of the door.

Note: Leave any additional room for any desired aisle or work area. Recommended minimum clearance around lift is three feet (3 ft) and above lift is four inches (4"). Ensure clearance conforms to local building and fire codes.

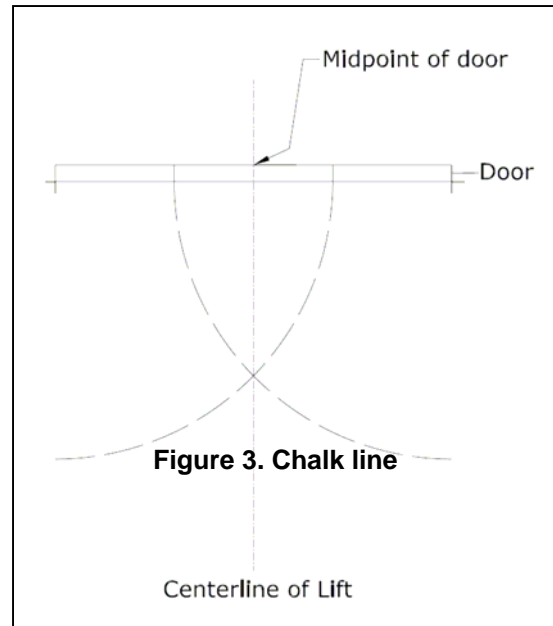

- 5.2.6 Measure the specified distance (126") to draw a second chalk line at 90° for locating the lift towers. Refer to Figure 3.
- 5.2.7 The lift is centered between the door and the walls of the area.

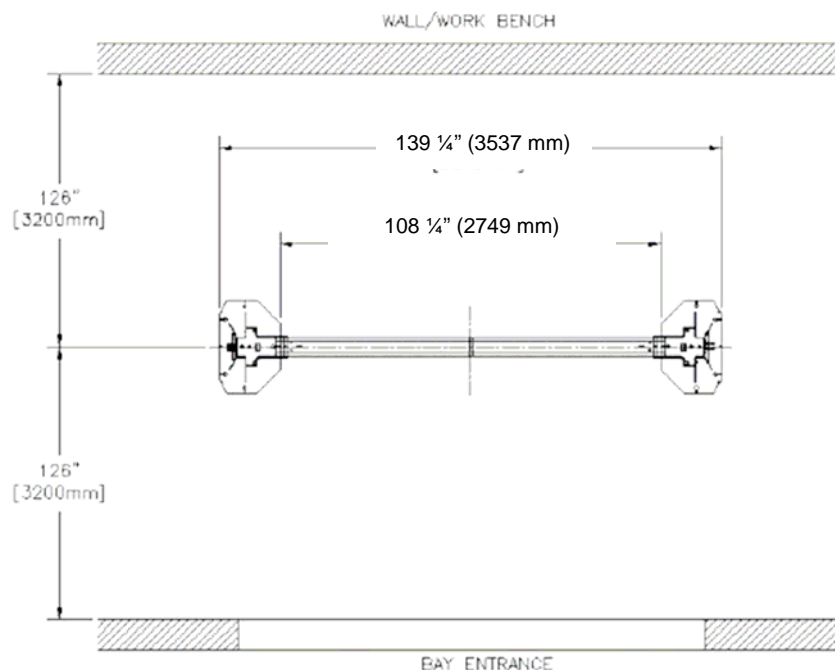
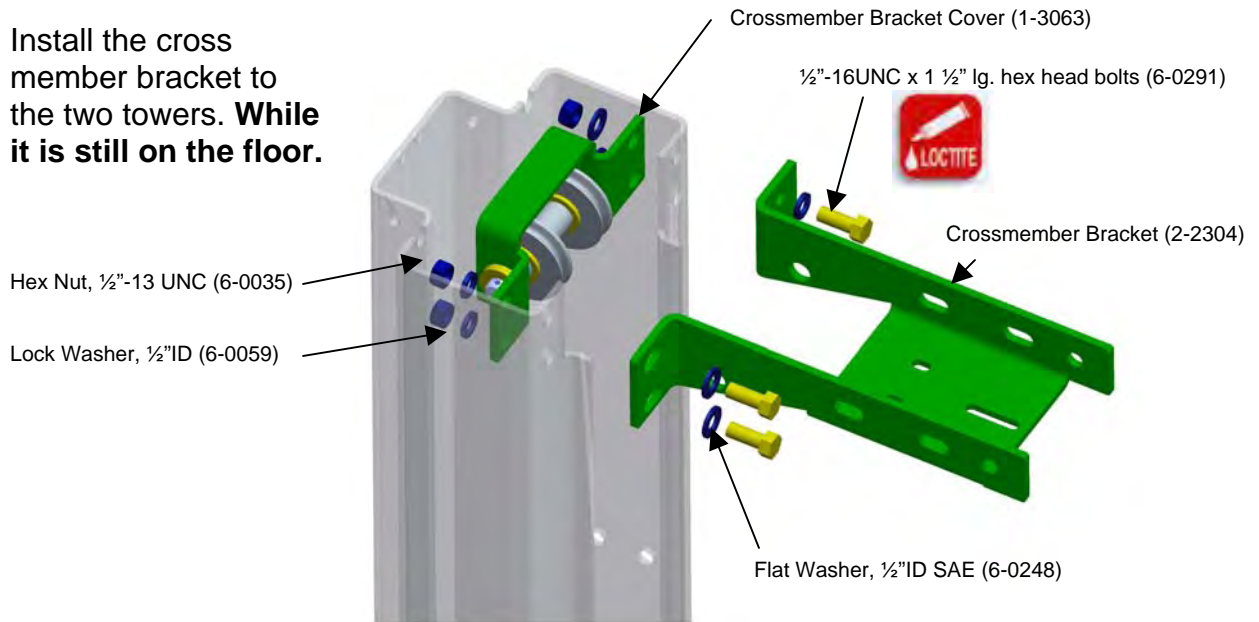

Figure 4. Bay Layout

5.3 CROSSMEMBER INSTALLATION

5.3.1 Install the cross member bracket to the two towers. **While it is still on the floor.**



5.3.2 Install the safety pulley on each tower.

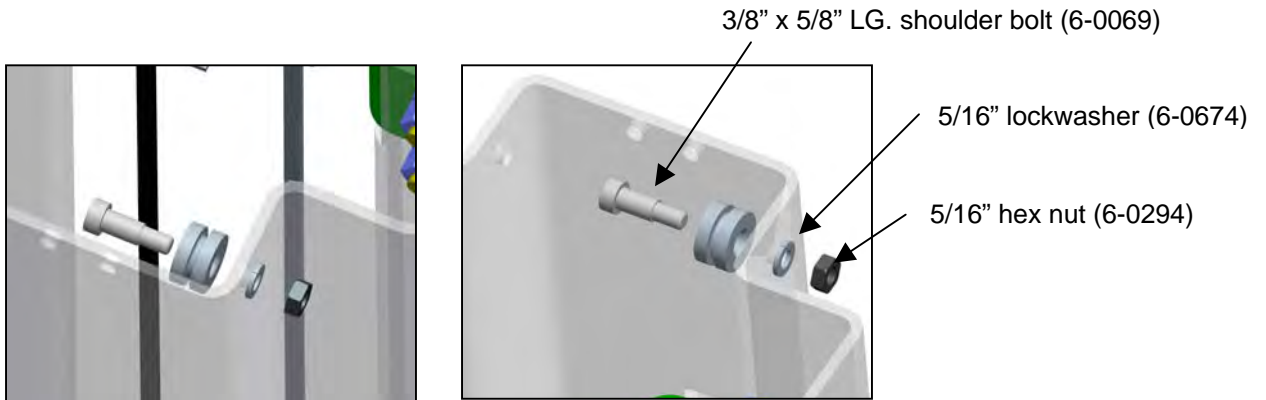

5.3.3 Stand towers in the position shown in bay layout.

5.3.4 Using a stepladder, install the crossmember. Install and tighten bolts.

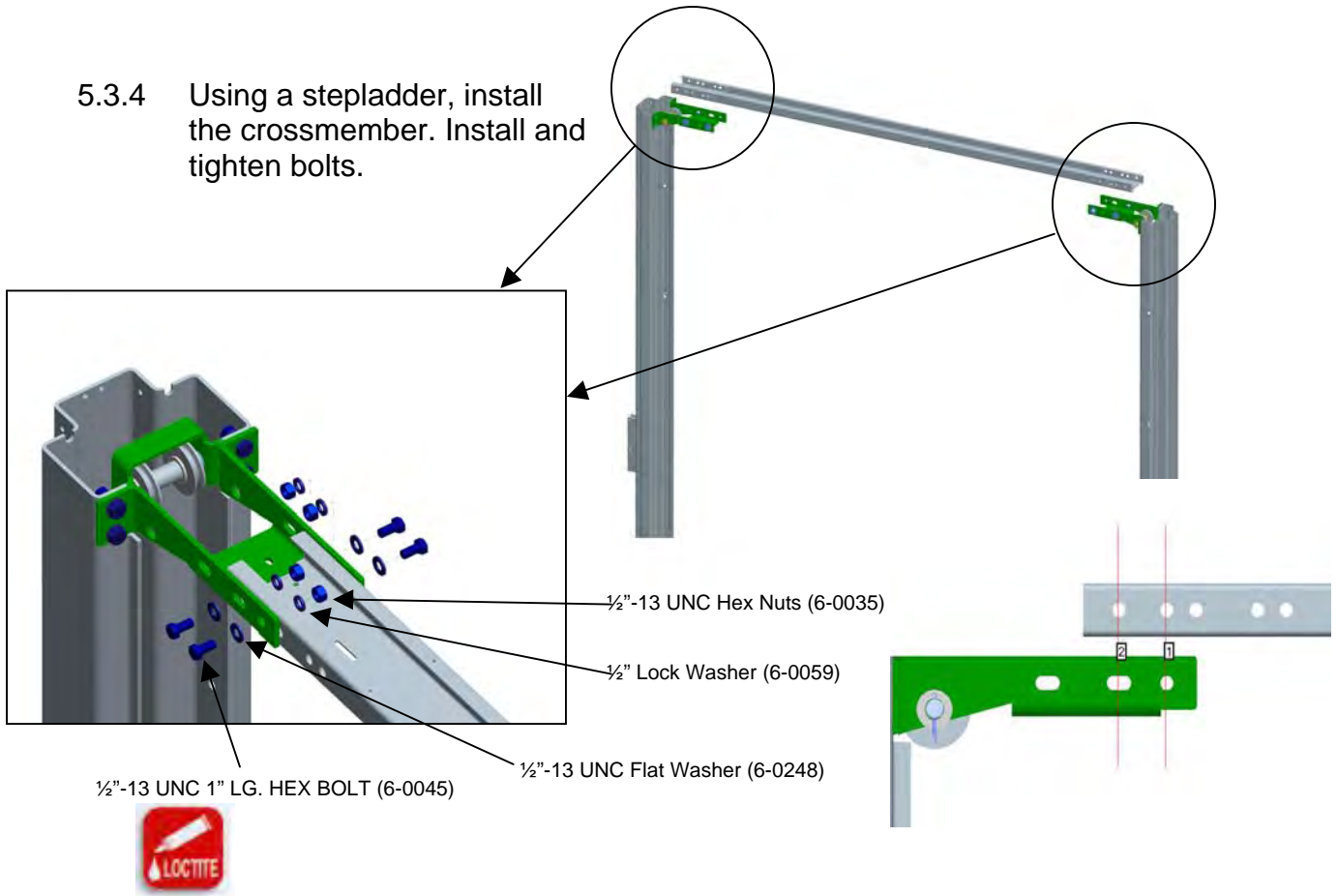

5.4 SAFETY SHUT-OFF BAR INSTALLATION

The safety shut off will disconnect the power to the power pack when an obstruction touches the padded bar or the carriages reach their maximum height. The safety shut off switch is factory pre-wired.

5.4.1 Attach the Actuator Mounting Bracket (1-1378) to the crossmember

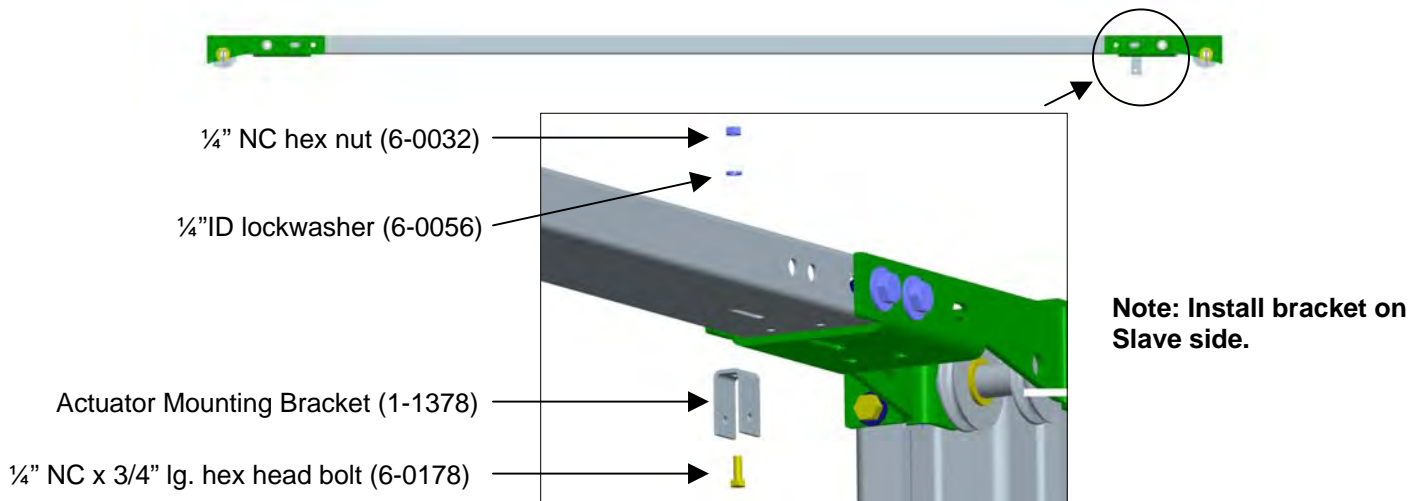

5.4.2 Attach the Microswitch Assembly (2-2024) to the crossmember.

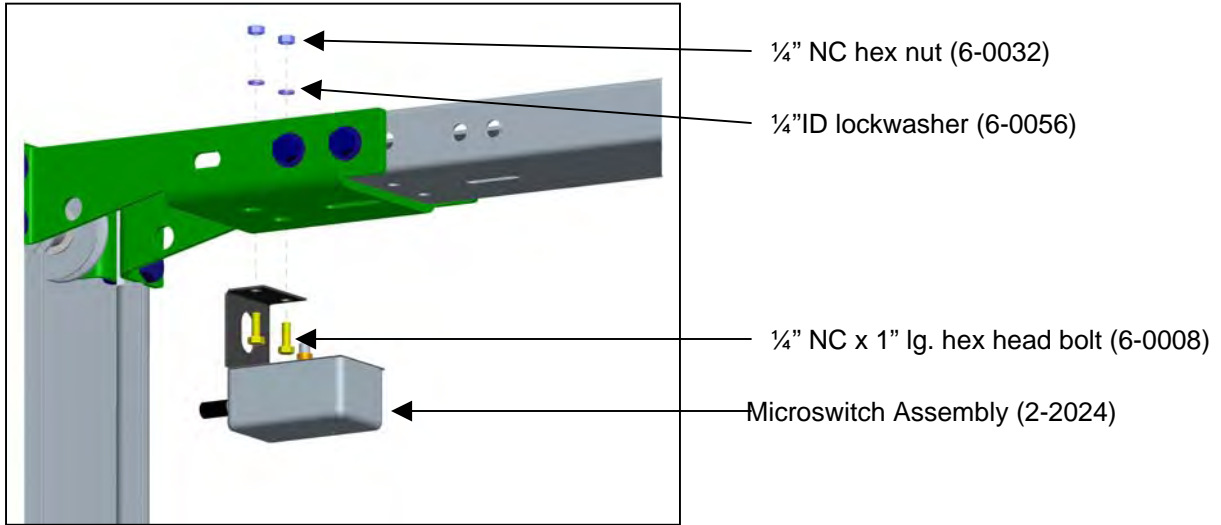

5.4.3 Slide the Actuator Bar through the Switch Bracket.

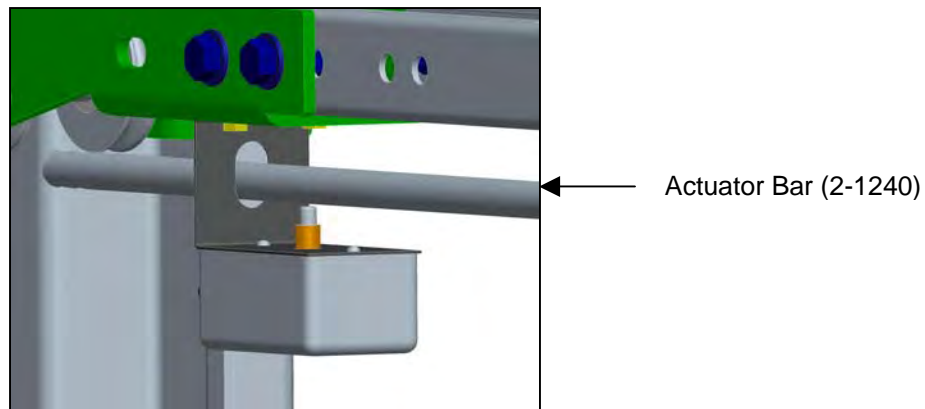

5.4.4 Attach the Actuator Bar to the Actuator Mounting Bracket.

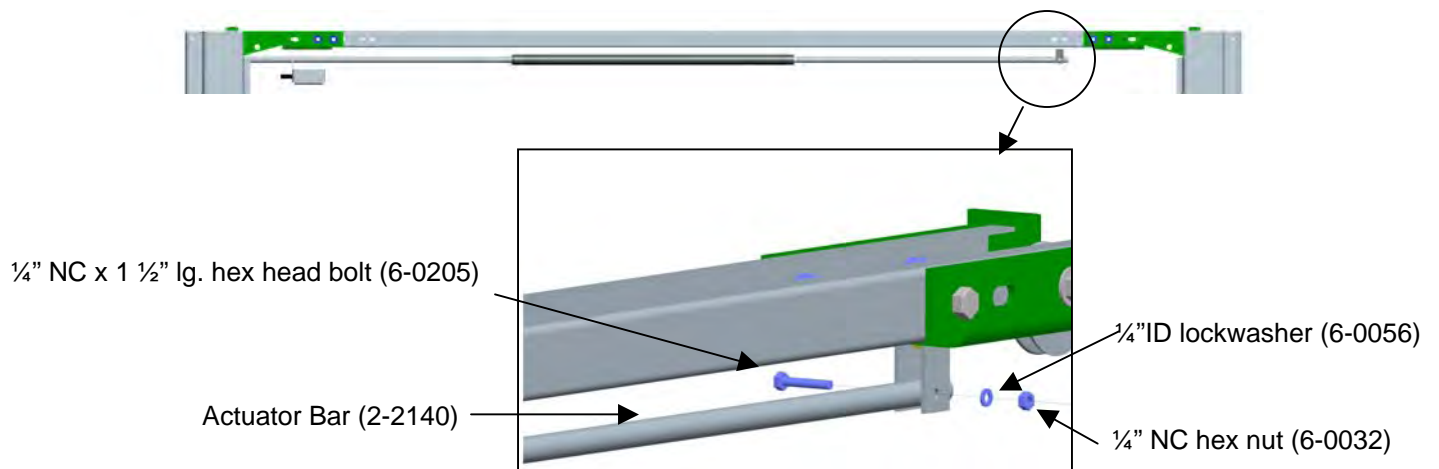

5.5 ROUTING OF EQUALIZATION CABLE

5.5.1 Manually lift the carriages to the first safety latch.

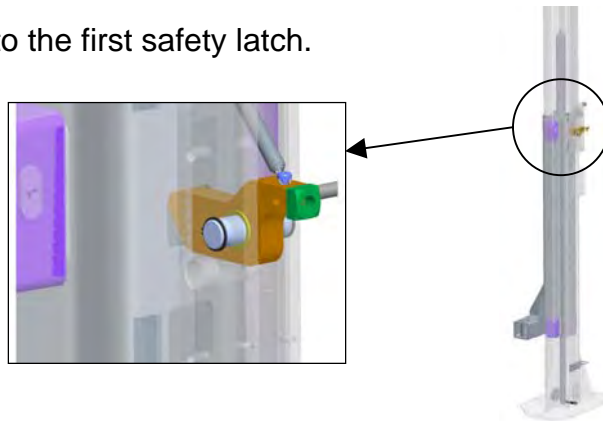

5.5.2 Remove equalizing cables (1-1786) from the accessory kit box, and 8 ½"- 13UNC nuts from a polybag in the hardware kit box.

5.5.3

Insert the short threaded stud through the 9/16" dia. hole at the bottom of the carriage.

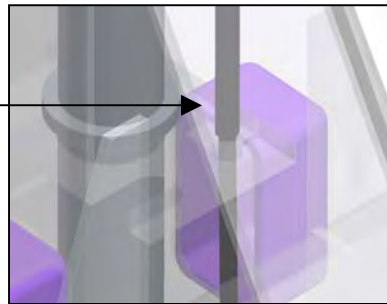

Transparent view of Carriage from Front.

Pass the cable until it reaches the top opening. Tighten a ½"-13UNC nut to the center of the stud, and then **firmly tighten** a second nut up against it using two wrenches.

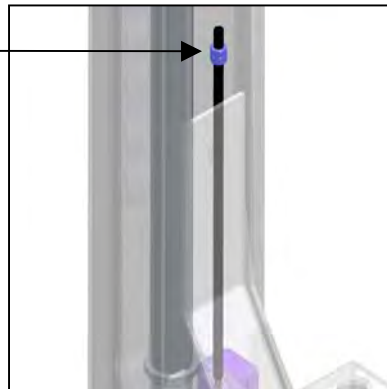

5.5.4 Pull the cable back down on to the carriage bottom plate.

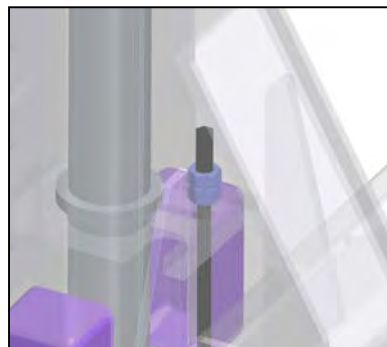

5.5.5 At the bottom of the column, remove the hitch pin, pulley pin and pulley from the base plate.

Pulley Assembly (1-1898)
Hitch Pin, 1/8" dia. (6-1841)
Head Pin (1-887)

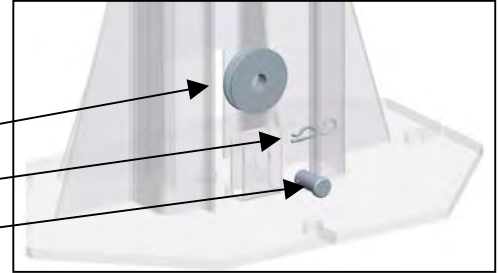

5.5.6 Route equalizing cable around pulley and reassemble the pulley to the base plate. **IMPORTANT – Hitch pin must be installed securely.**



5.5.7 Route Cable as shown.

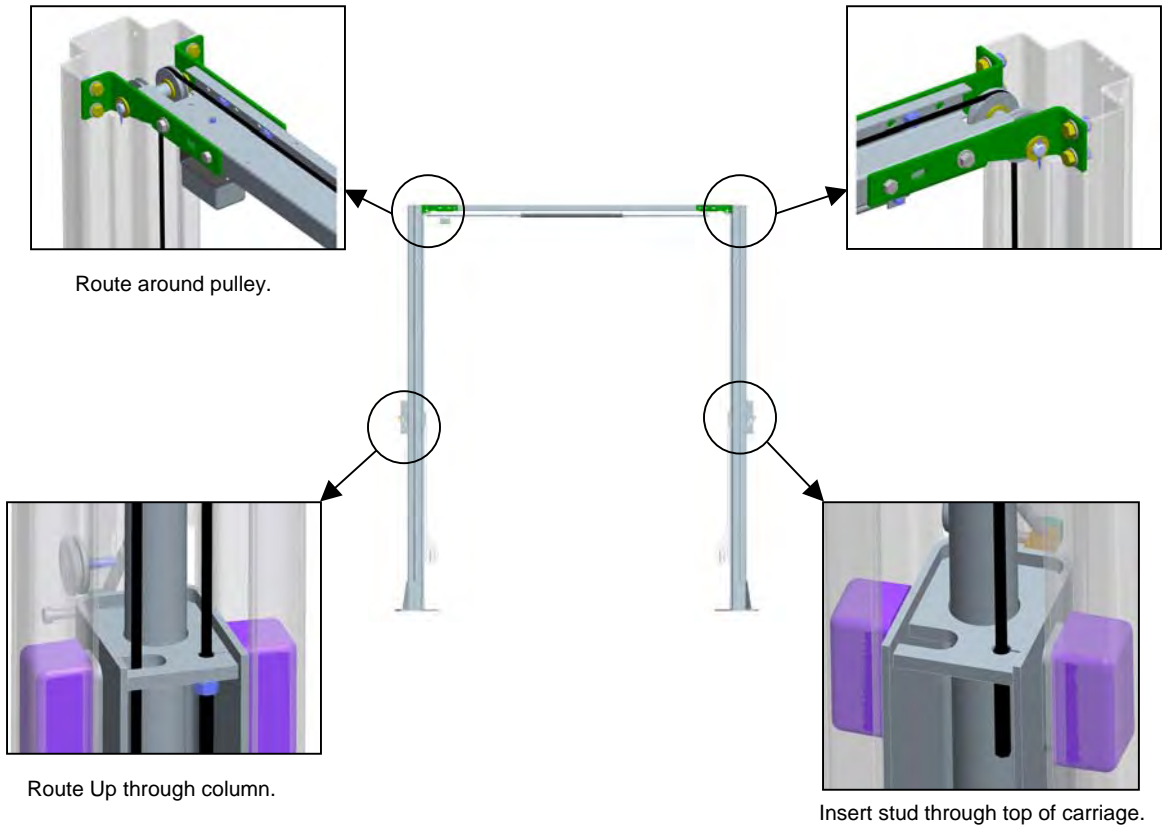

5.5.8

Use a wrench to hold the top of the threaded stud to prevent it from rotating.

Hand tighten (2) ½"-13 UNC nuts onto the threaded stud enough to remove all visible cable slack

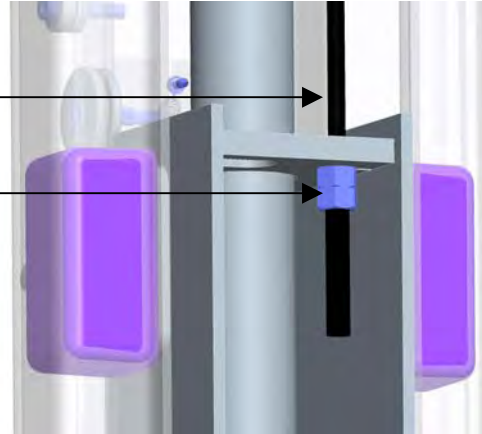

5.5.9

Hold the top of the threaded stud using wrench.

Tighten the first nut approximately 1 ½" to tension cable.

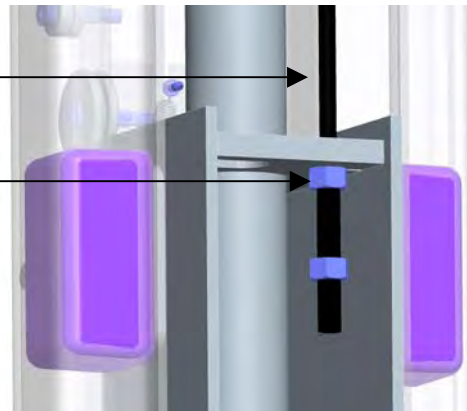

5.5.10

Tighten the second nut firmly against the first one.

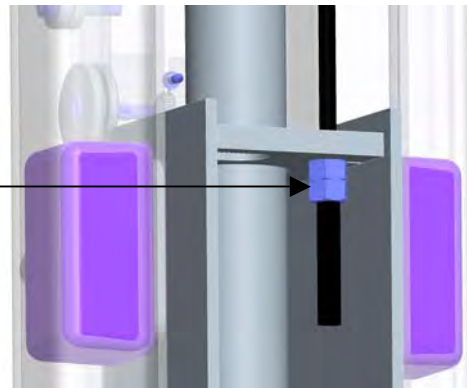

5.5.11 Repeat steps for other cable.

5.6 ARM INSTALLATION

5.6.1 Remove the Arm Pins from all four Arms.

5/16"-18UNC x 3/4"LG. hex head bolt (6-0423)

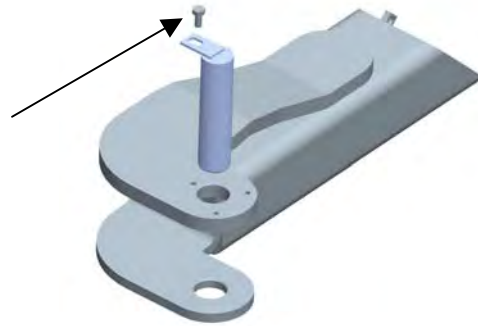

5.6.2 Install the four arms on the carriages by inserting the arm pins.

5/16"-18UNC x 3/4"LG. hex head bolt

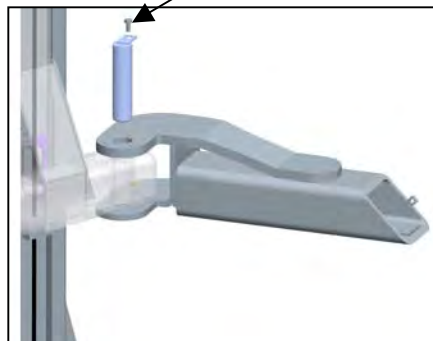
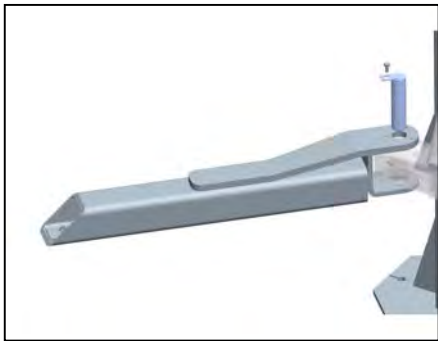

5.6.3 Install Arm Restraint Gear.

5/16"-18UNC x 1 1/4" LG. hex head bolt (6-2059)



5/16" Flat Washers (6-0295)

Arm Restraint Gear (1-2618)

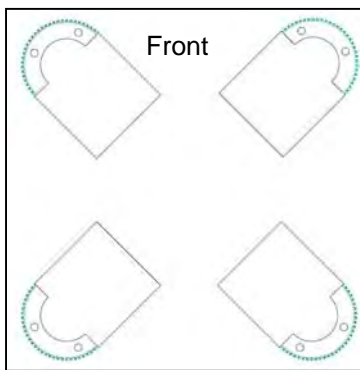
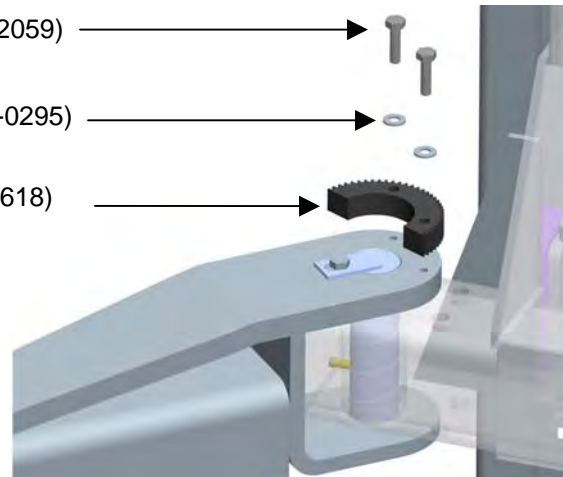

Orientation of Gears.

5.7 ARM RESTRAINT INSTALLATION

5.7.1

Insert arm lock handle weldment (1-2914) through holes in carriage weldment.

Loosen the two 5/16" hex bolts

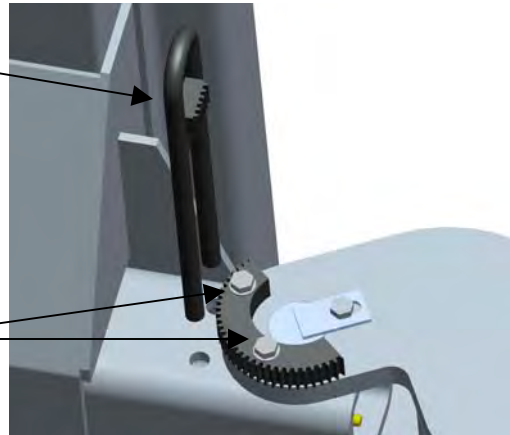

5.7.2

Adjust arm restraint gear so that lock engages smoothly through entire range of arm motion. **Tighten both 5/16 hex bolts.**



5.7.3 Repeat above steps for all arms.

5.7.4 Slide arm lock spring over outboard leg of arm lock handle (leg which is nearest tower).

Arm Lock Spring (1-2942)

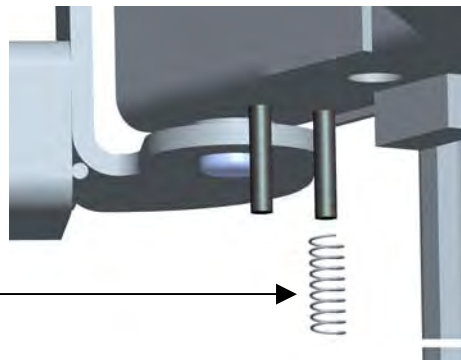

5.7.5 Hammer a spring retainer cap to the end of the arm lock leg.

Spring Retainer Cap (6-3086)

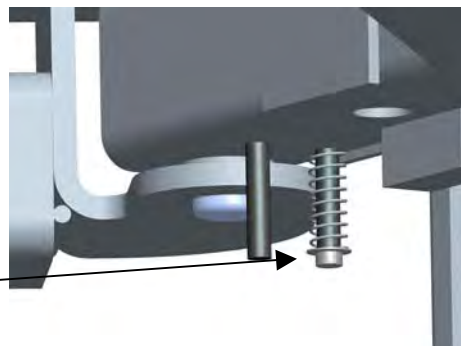

5.8 SAFETY RELEASE CABLE ROUTING AND ADJUSTMENT

The mechanical safety automatically engages. To release the mechanical safety, you must first raise the lift approximately 2", then pull the safety release lever down. This disengages the power side safety dog and activates the safety cable to release the slave side safety dog.

- 5.8.1 Install the safety release handle (1-1113) onto the power side safety dog.

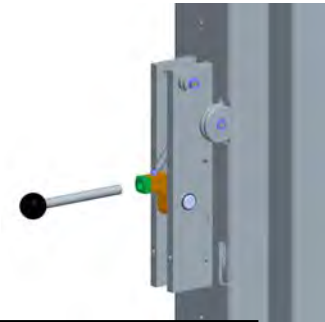

- 5.8.2

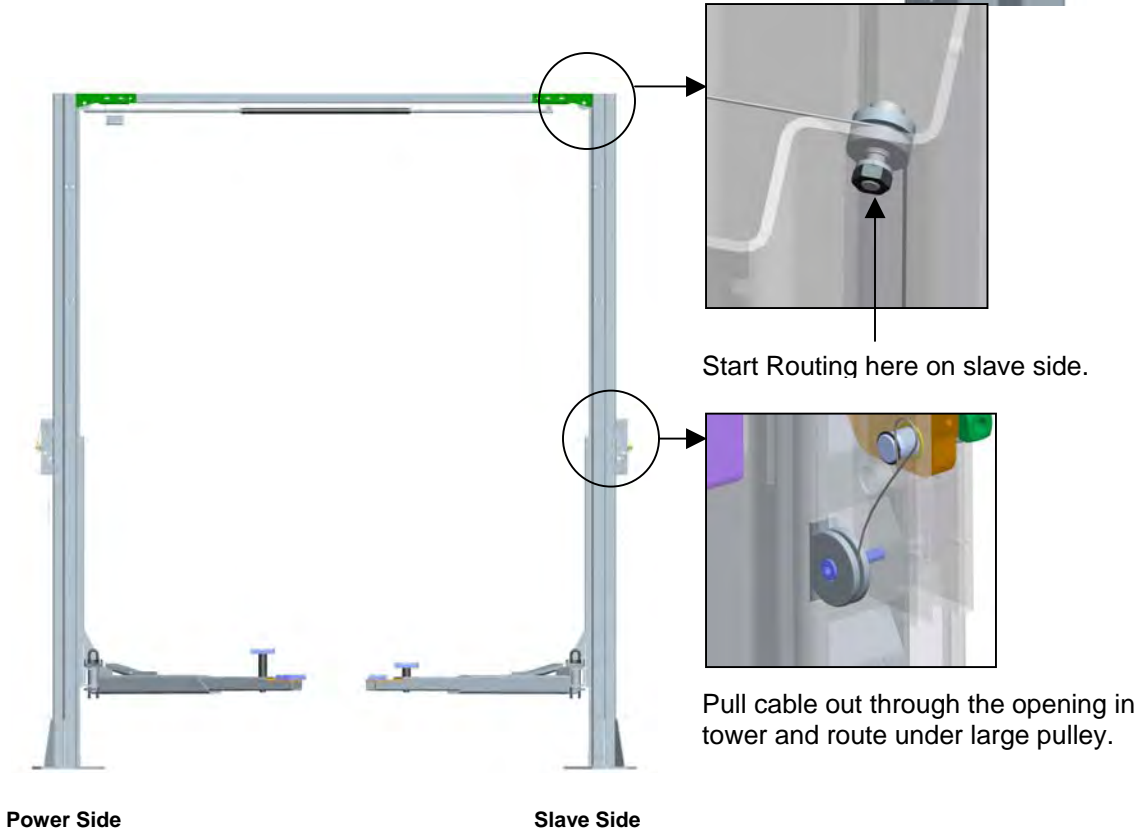

5.8.3 Fix the collar of the safety release cable to the shoulder bolt on the safety dog.

NOTE: Make sure shoulder bolt, 3/8" dia. x 1 1/2" lg. (6-0801), is lock tight to safety dog.

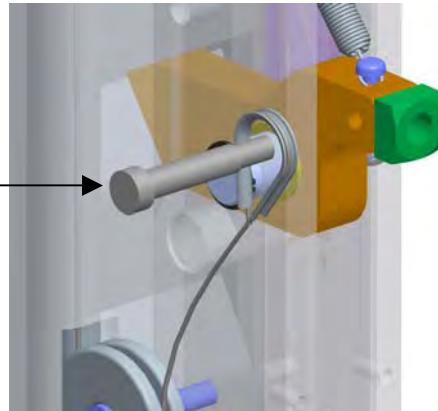

5.8.4

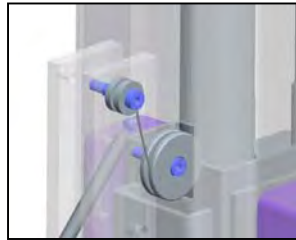

Guide the cable up under the large pulley on the power side.



Over the small pulley towards the safety dog.

Power Side

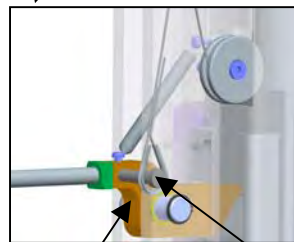

Wrap around the Thimble (6-2074)

3/8" x 1 1/2" lg. shoulder bolt (6-0801)

Slave Side

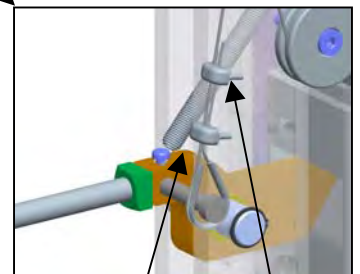

Clamp using wire rope clips (6-2060)



Do not tighten fully at this stage.

5.8.5 Adjust the cable length so that both safety dogs travel from full engagement position to full release position when the safety release handle is pulled.

Tighten both wire rope clips firmly when adjustment is completed.

5.9 POWER PACK INSTALLATION

- 5.9.1 Remove the **red** plastic cap located at the rear of the power pack, and install the "T" fitting located in the hardware kit.

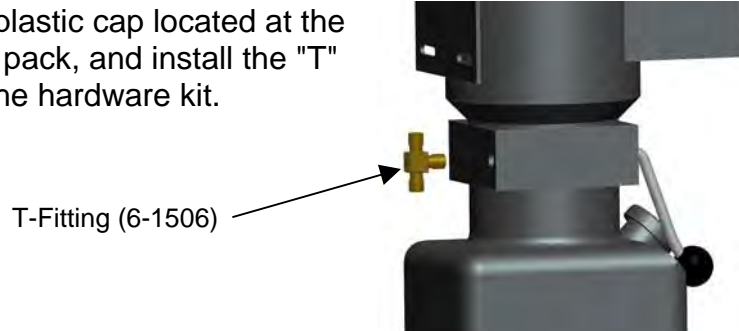

- 5.9.2 Bolt power pack to the mounting bracket on the power side tower using hardware from the kit. **Do not tighten.**

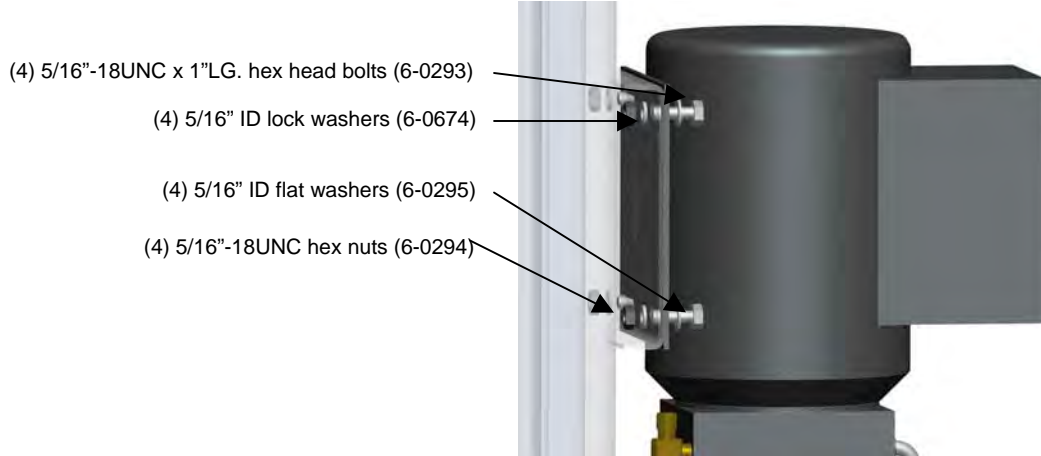

- 5.9.3 Remove the filler cap from the powerpack and fill the reservoir with approximately 4.5 Gal. (18L) of ISO32 hydraulic oil (10 wt. hydraulic oil).

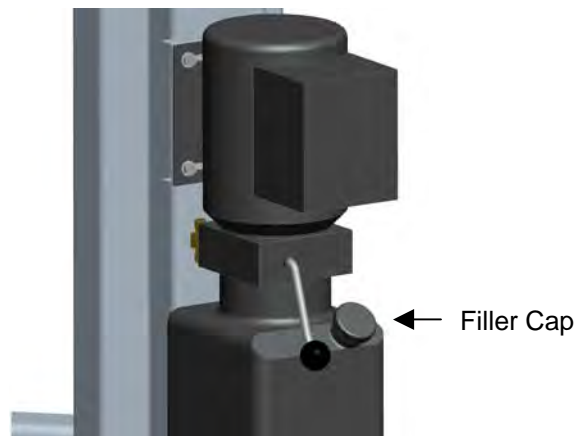

5.9.4 A **certified electrician** must connect the 230Volt/1Ph power to the motor.

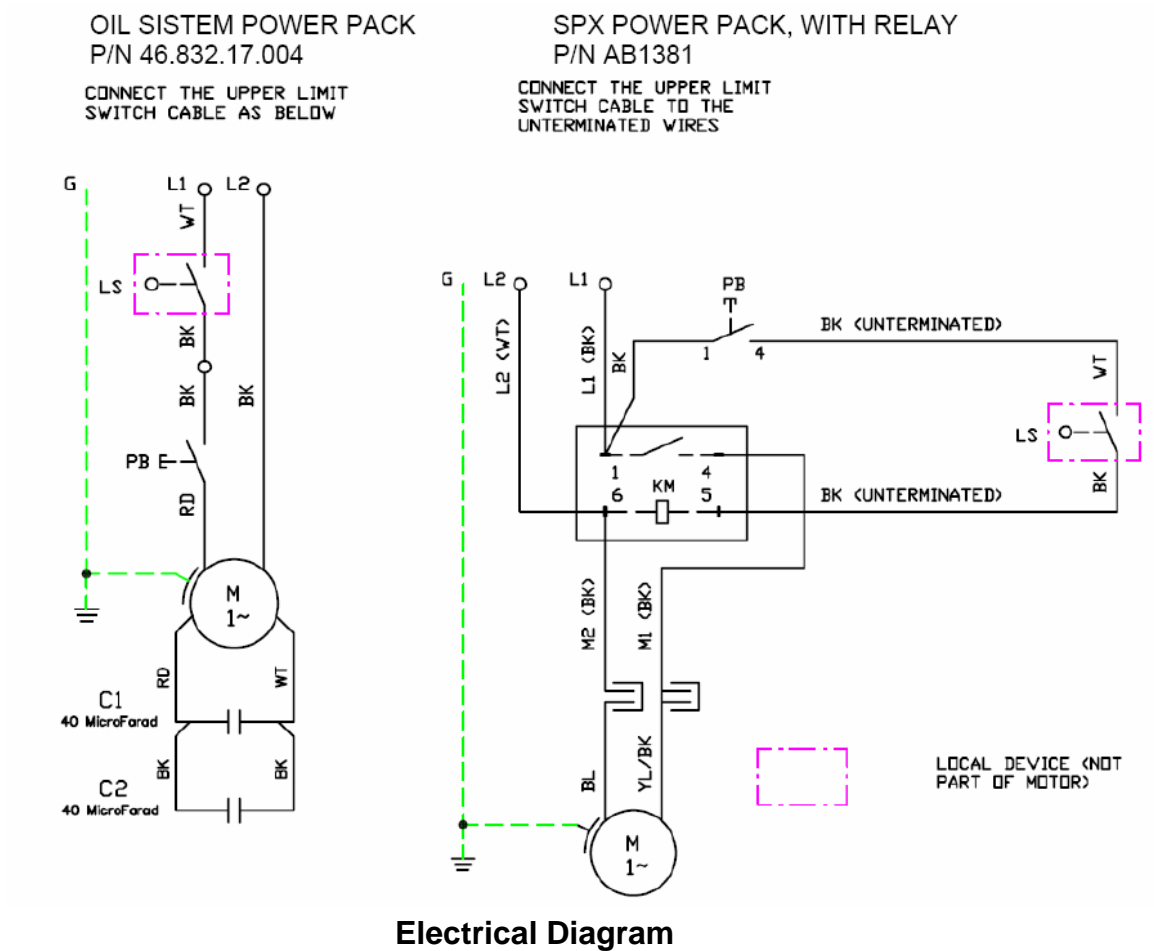

5.10 HYDRAULIC SYSTEM INSTALLATION

5.10.1 Connect long hose to the top port on “T” fitting.

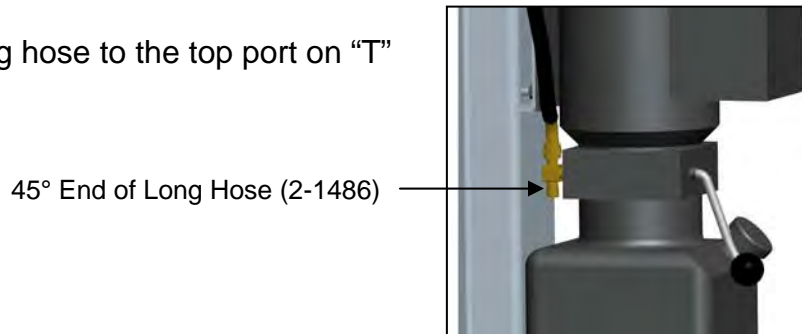

5.10.2 Connect short hose to the other end of the "T" fitting.

45° End of Short Hose (2-1230)

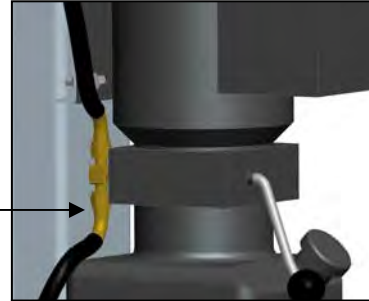

5.10.3 Remove the plastic cap from the bottom of the power side cylinder and connect the short hose to the cylinder.

90° End of Hose

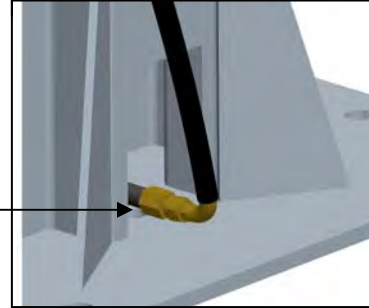

5.10.4

Loop the hydraulic hose up the power side tower, across the overhead and down the slave side tower.

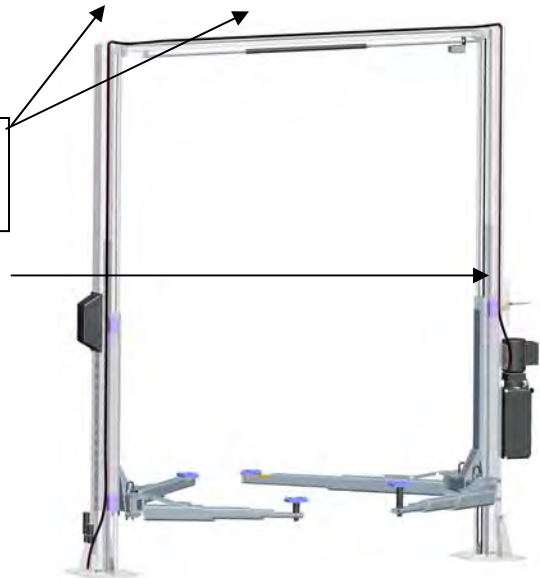

5.10.5 Remove the plastic cap from the bottom of the slave side cylinder and connect the long hose to the cylinder.

90° End of Hose

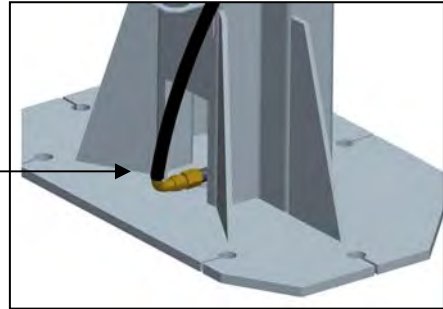

5.10.6

Tube clamp (6-1547)

#10 x 3/8" LG. Self Tapping (6-0169)

Place 3 tube clamps on crossmember.

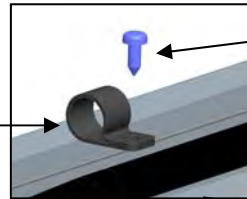

1/4"-20UNC x 3/8"lg. round head screws (6-1353)

Use 6 tube clamps to secure the long and short hydraulic hoses to the Towers.

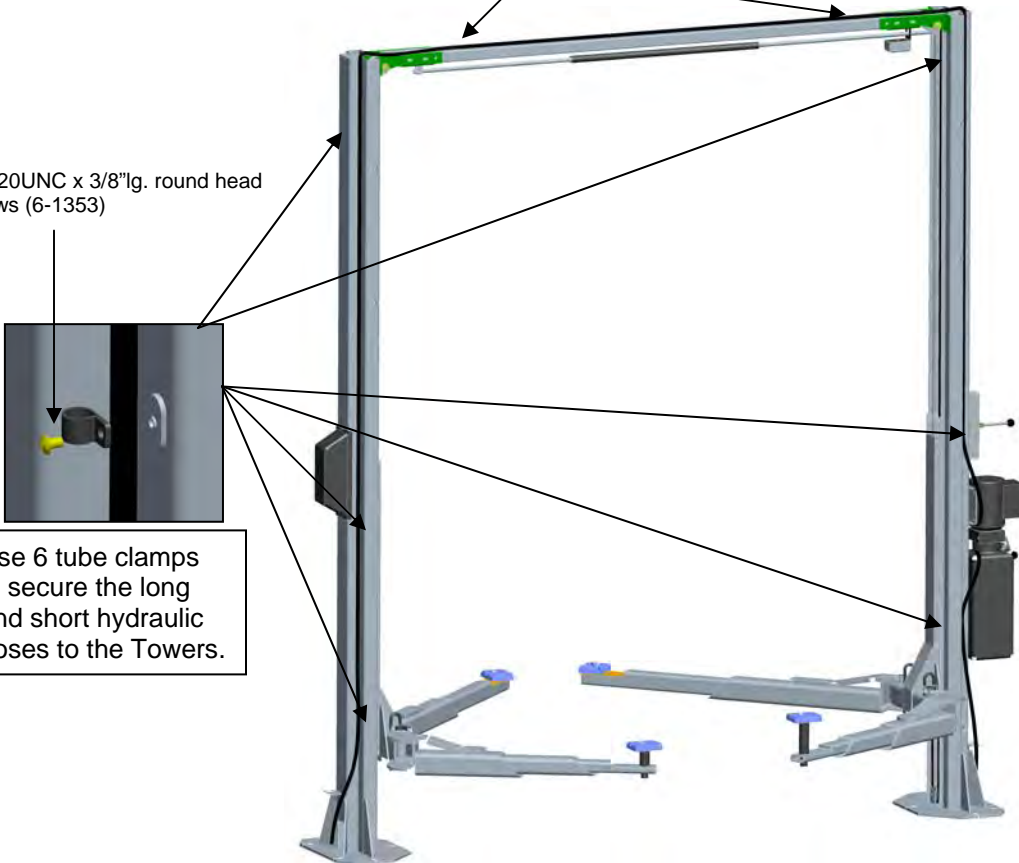

5.11 HYDRAULIC SYSTEM BLEEDING

- 5.11.1 Crack the bleeder valve located at the top of both cylinders (approx. $\frac{1}{4}$ turn)

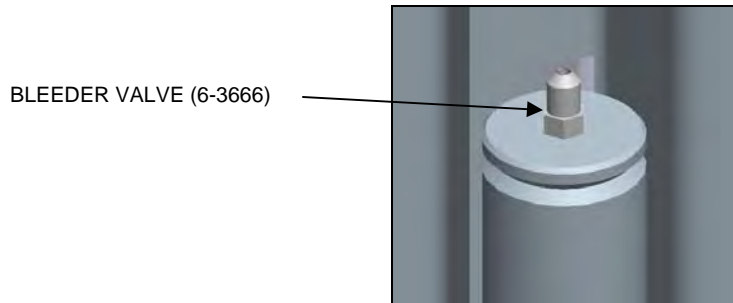

- 5.11.2 Power up 2"-3". You should hear air escaping around the bleeder valve. Repeat 3 – 4 times or until only oil is coming out of the bleeder valve.
- 5.11.3 Tighten the bleed screw and lower the lift.

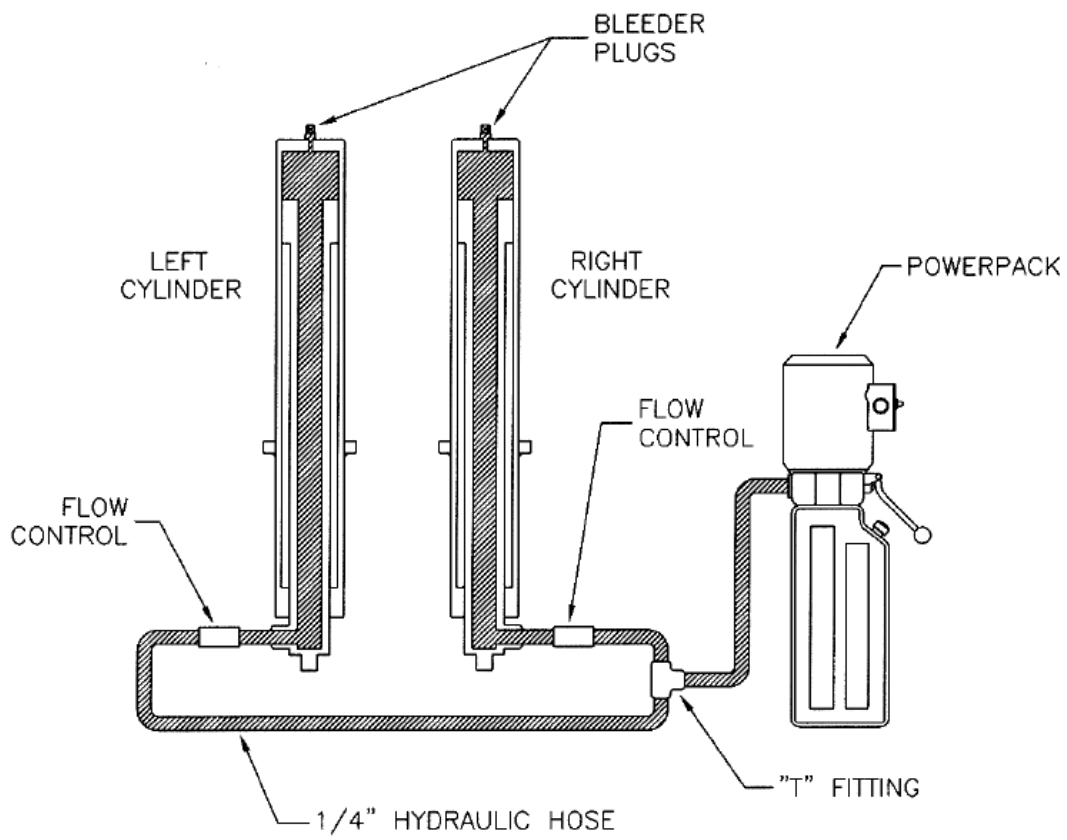

5.12 TOWER POSITIONING AND ANCHORING

WARNING! Failure to follow these instructions may cause an unsafe operating condition.

WARNING! Before proceeding with installation, review Section 4: Installation & Tools.

- 5.12.1 Determine which column is higher using a 4ft level.

Place 4 ft. Level.

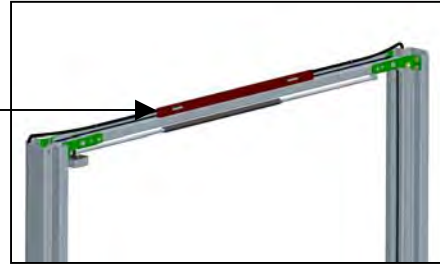

- 5.12.2 Check if high column is level in the vertical position.

Place 2 ft. Level.

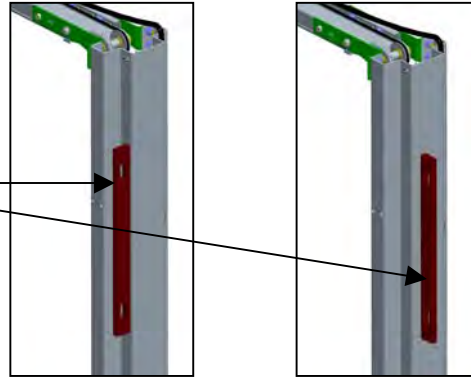

Note: Use shims under baseplate to level the column.

Ensure that the base plate is completely supported by shims including near the center where it does not contact the floor.

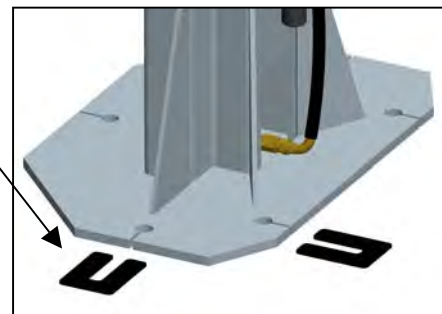

5.12.3 Refer to Bay Layout to ensure that the column is still in the proper position.

5.12.4 Prior to installing anchors, assemble the nut and washer onto anchors. A minimum of six threads must be visible below the surface of the nut. Refer to the figure below while reading through the following instructions.

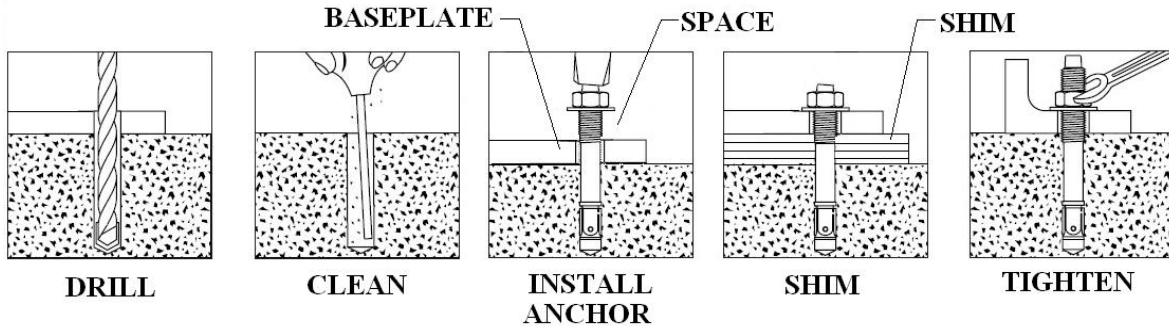

5.12.5 Using a $\frac{3}{4}$ " concrete drill bit and rotary hammer drill, drill $\frac{3}{4}$ " holes for the anchor bolts on the high side column. Drill through the concrete floor. (In case longer anchors are required, supplied anchors can be hammered through concrete).

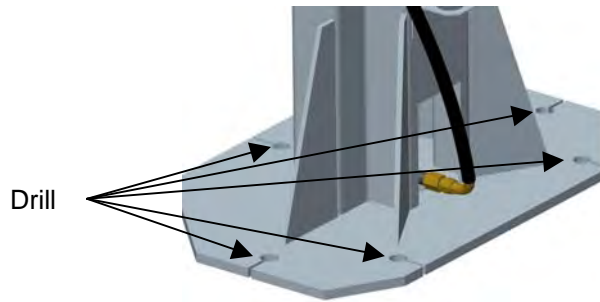

5.12.6 Clean out the drilling dust from the holes and hammer in the anchors until they make contact with the baseplate. **Hand tighten all anchor bolts.**

Check that the column is level front to rear and side to side. Adjust shims as required.

5.12.7 **Torque all anchor bolts to 150 ft-lbs. (203 Nm)**, continually checking that the column is level as you proceed.



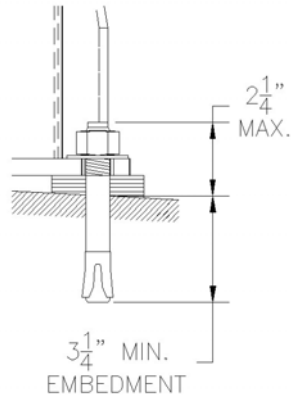

NOTE:

The 3/4" × 5 1/2" lg. wedge anchor bolts supplied must have a minimum embedment of 3 1/4" into concrete floor.

If anchor bolts do not tighten to 150 ft-lbs. OR project more than 2 1/4" above the concrete surface due to floor slope, the concrete should be replaced by an appropriate concrete pad. (Consult Product Manufacturer / Supplier for further details).

5.13 POSITION AND ANCHORING OF REMAINING TOWER

5.13.1 Level the low side column by shim underneath the baseplate.

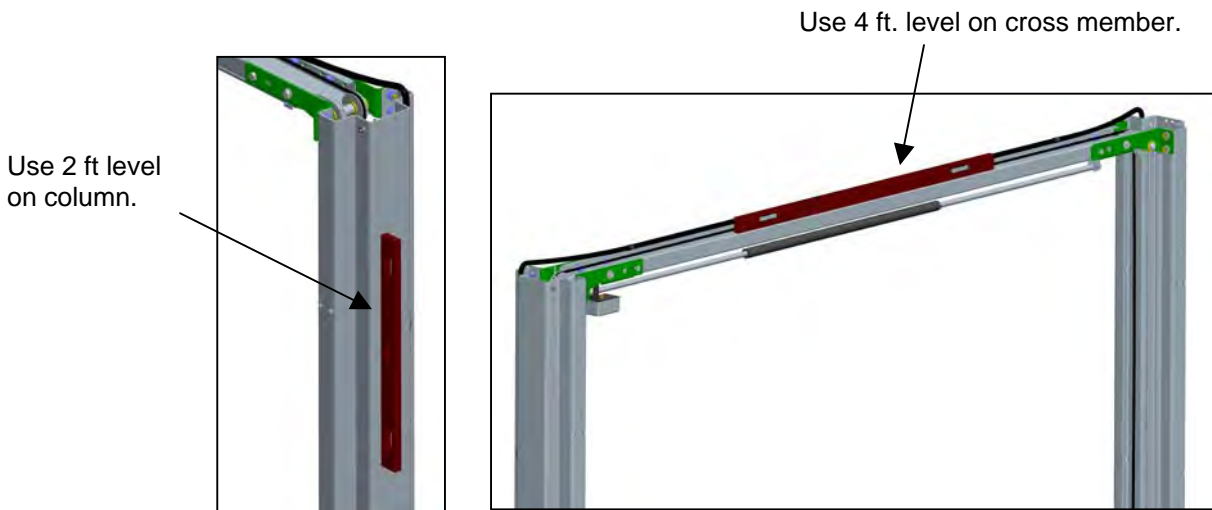

Ensure that the baseplate is completely supported by shims where it does not contact the floor.

5.13.2 Refer to Bay Layout to ensure that the column is still in the proper position.

5.13.3 Prior to installing anchors, assemble the nut and washer onto anchors. A minimum of six threads must be visible below the surface of the nut. Refer to the figure below while reading through the following instructions.

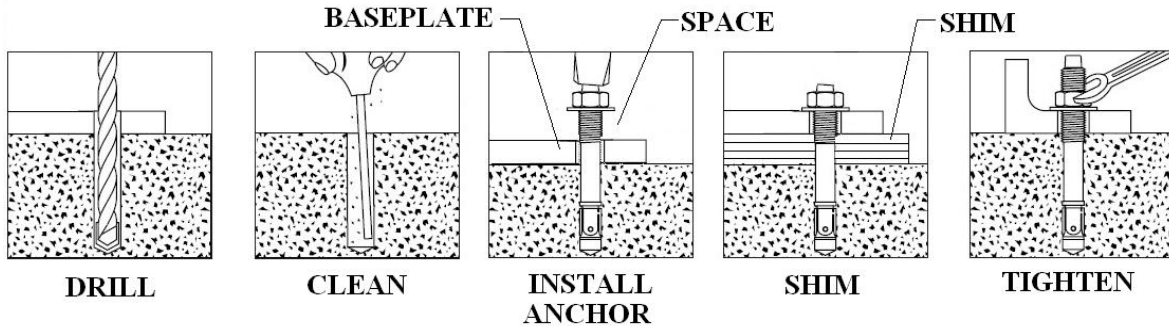

5.13.4 Using a $\frac{3}{4}$ " concrete drill bit and rotary hammer drill, drill $\frac{3}{4}$ " holes for the anchor bolts on the high side column. Drill through the concrete floor. (In case longer anchors are required, supplied anchors can be hammered through concrete).

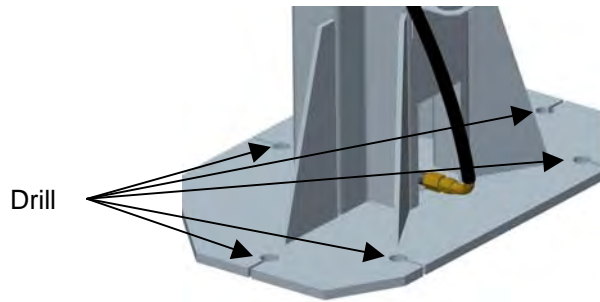

5.13.5 Clean out the drilling dust from the holes and hammer in the anchors until they make contact with the baseplate. **Hand tighten all anchor bolts.**

Check that the column is level front to rear and side to side. Adjust shims as required.

5.13.6 **Torque all anchor bolts to 150 ft-lbs. (203 Nm)**, continually checking that the column is level as you proceed.



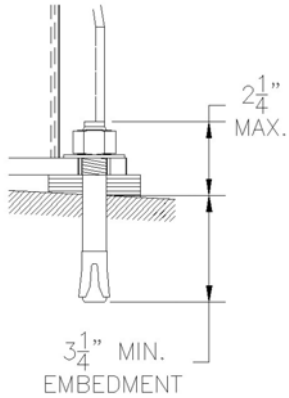

NOTE:

The 3/4" × 5 1/2" lg. wedge anchor bolts supplied must have a minimum embedment of 3 1/4" into concrete floor.

If anchor bolts do not tighten to 150 ft-lbs. OR project more than 2 1/4" above the concrete surface due to floor slope, the concrete should be replaced by an appropriate concrete pad. (Consult Product Manufacturer / Supplier for further details).

5.13.7 Verify that the entire lift is level both horizontally and vertically to ensure optimum lifting performance. **NOTE: Perform a monthly inspection and torque all anchor bolts to 150 ft-lbs. (203 Nm).**

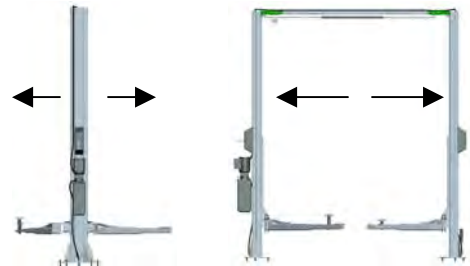

5.14 SAFETY SHUT-OFF BAR ADJUSTMENT

5.14.1 When the lift is fully installed, leveled and operational, extend the carriages to their full upper limit.



5.14.2 Lower the carriages about ¼" to ½".

5.14.3 Attach a ¼ bolt and nut to actuator extension.

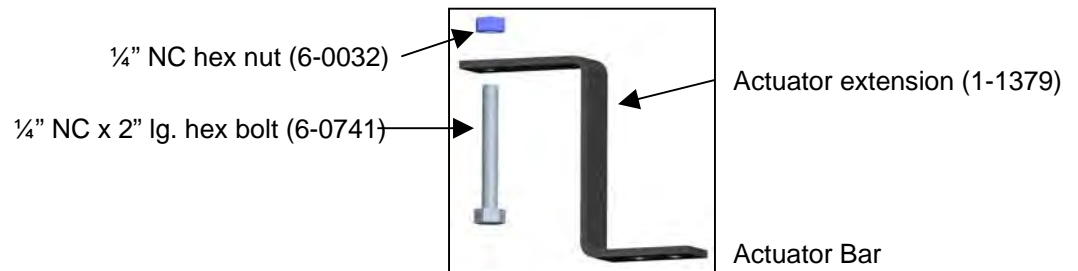

5.14.4 Bolt the Actuator Extension onto the open end of actuator bar.

¼" NC x 1 ¼" lg. hex head bolts (6-0027)

Actuator Extension

¼" ID lockwashers (6-0056)

¼" NC hex nuts (6-0032)

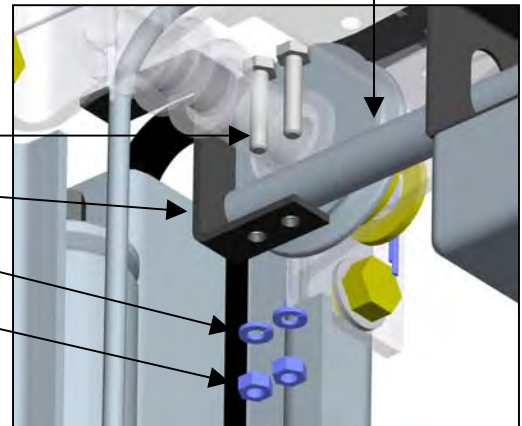

5.14.5 Adjust the ¼" NC x 2" lg. hex bolt so that the end of the bolt is in contact with the carriage. Tighten the ¼" NC hex nut on the bolt.

Hex bolt in Contact with Carriage.

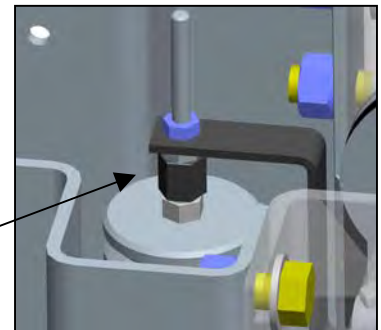

5.15 FINAL CHECK OF ASSEMBLED LIFT

1. Final dimension check after anchoring. _____
2. Check for hydraulic leaks. _____
3. Ensure cables are properly routed and free from obstructions. _____
4. Check jam nuts on cables are tightened. _____
5. Check that LOCTITE has been applied to all hardware where required. _____
6. Check adjustment of safety release cable to ensure both sides working properly. _____
7. Re-check level of towers. _____
8. Check torque of anchor bolts. _____
9. Check all fasteners, tighten if necessary. _____
10. Check shut off at top of stroke to ensure lift shuts off. _____
11. Check proper operation of arm restraints. _____
12. Operate lift to full stroke then lower to ground while checking for proper functionality. _____
13. Ensure Customer Care Kit is complete and given to operator. _____
 - a. Operation Manual _____
 - b. ANSI / ALI Lift It Right Manual _____
 - c. ANSI / ALI Safety Tip Card _____
 - d. ANSI / ALI ALIS Safety Requirements for Installation and Service of Automotive Lifts _____
 - e. ANSI / ALI Quick Reference Guide _____
14. Train end user on operation of lift. _____

5.16 OPERATION TEST WITH VEHICLE

1. Lower lift to ground.
2. Drive vehicle on to lift and locate the arms as per the "Lift it Right" manual.
3. Raise lift to and lower onto 3-4 lock positions during full rise to ensure all locks are working correctly.
4. Re-adjust cables if necessary while vehicle is on.
5. Check lowering speed and smooth decent rate.
6. Lower lift to ground and drive vehicle off lift.

If any problems occur during the final checkout or operation of the lift please contact customer service at 1-800-268-7959

6.0 LIFT MAINTENANCE GUIDELINES

6.1 SAFETY INSTRUCTIONS

Read operating and safety manuals before using any lift.
Do not operate a lift that has been damaged or is in disrepair.
Proper inspection and maintenance is necessary for safe operation.

6.2 PERIODIC MAINTENANCE

DAILY:

1. Check all hydraulic lines and fittings for pinch points , damage , cracks or leaks
2. Check all electrical wiring for pinch points , cracks or damage
3. Check all moving parts for uneven or excessive wear
4. Repair or replace all damaged, defective, worn or broken components immediately.
5. Check the telescopic arms for movement. Clean any grease or oil from the lifting adapters.
6. Raise and lower the lift at the beginning of each shift, without a vehicle on, to verify the lift is leveled and operating properly.

EVERY TWO MONTHS:

1. Clean and re-grease slide block channels inside of both columns
2. Grease arm pins
3. Lubricate safety dogs and check safety release cable adjustment
4. Check arm restraints and lubricate
5. Check anchor bolts and re-torque if required

EVERY FOUR MONTHS:

1. Dismantle and clean inner arms
2. Lubricate cable pulleys
3. Check equalizing cable adjustment

EVERY YEAR:

1. Inspect lift as per Automotive Lift Operation, Inspection and Maintenance (ALOIM)

EVERY TWO YEARS:

1. Change hydraulic fluid

LUBRICATION:

Where grease is required > multi-purpose lithium grease

Where lubricating oil is required > multi-purpose SAE 30 lubricating oil

Where hydraulic oil is required > ISO 32 10W - non detergent hydraulic oil

NOTE: If the lift locks, while in the fully raised position this will indicate that the hydraulic system has not been inspected or maintained as recommended. This is a safety back-up system. If you are unclear call your local representative immediately.

7.0 SAFETY AWARENESS

AUTOMOTIVE LIFT INSTITUTE (ALI)

<p>SAFETY INSTRUCTIONS</p>  <p>Read operating and safety manuals before using lift.</p>	<p>SAFETY INSTRUCTIONS</p>  <p>Do not operate a damaged lift.</p>	<p>SAFETY INSTRUCTIONS</p>  <p>Proper maintenance and inspection is necessary for safe operation.</p>
<p>CAUTION</p>  <p>Always use safety stands when removing or installing heavy components.</p>	<p>CAUTION</p>  <p>Authorized personnel only in lift area.</p>	<p>CAUTION</p>  <p>Auxiliary adapters may reduce load capacity.</p>
<p>CAUTION</p>  <p>Lift to be used by trained operator only.</p>	<p>CAUTION</p>  <p>Use height extenders when necessary to ensure good contact.</p>	<p>CAUTION</p>  <p>Use vehicle manufacturer's lift points.</p>
<p>WARNING</p>  <p>Avoid excessive rocking of vehicle while on lift.</p>	<p>WARNING</p>  <p>Clear area if vehicle is in danger of falling.</p>	<p>WARNING</p>  <p>Do not override self-closing lift controls.</p>
<p>WARNING</p>  <p>Keep feet clear of lift while lowering.</p>	<p>WARNING</p>  <p>Position vehicle with center of gravity midway between adapters.</p>	<p>WARNING</p>  <p>Remain clear of lift when raising or lowering vehicle.</p>

8.0 PARTS LIST

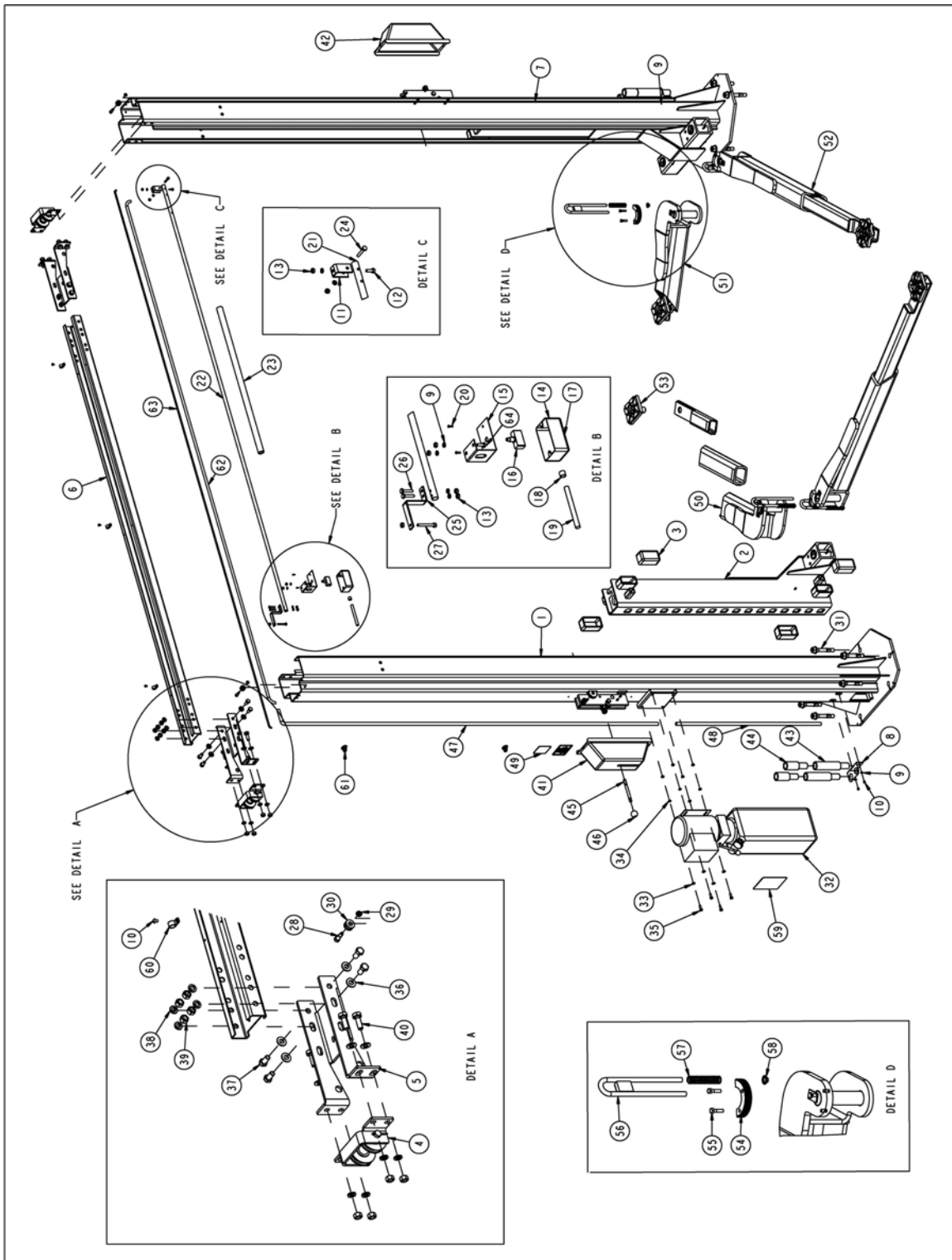

Item#	Part #	Description	Qty.
1	4-1018-4	TOWER ASSEMBLY POWER SIDE	1
2	4-1162	FORMED CARRIAGE WELDMENT	1
3	2-0772	SLIDER BLOCK	4
4	2-2317	10K SYM. EQUALIZING PULLEY ASSY.	2
5	2-2304	SYMMETRIC CROSSMEMBER BRKT	2
6	2-2323	CROSSMEMBER CHANNEL	1
7	4-1019-4	TOWER ASSEMBLT SLAVE SIDE 10K 2N1 12FT	1
8	1-2012	ADAPTER HOLDER	2
9	6-0056	Lock Washer, 1/4" I.D.	10
10	6-1353	Round HD. MACH. Screw 1/4"-20 x 3/8" LG.	7
11	1-1378	ACTUATOR MOUNTING BRACKET	1
12	6-0178	Hex Bolt, 1/4" x 3/4" LG.	1
13	6-0032	Hex Nut, 1/4"-20UNC	7
14	2-2024	Microswitch Assembly	1
15	2-1143	LIMITING SWITCH BRACKET	1
16	6-0916	Microswitch	1
17	6-1403	Electrical Utility Box	1
18	6-1133	Cable Connector	1
19	6-1173	Elec. Cable 12/3 x 117" LG.	1
20	6-1466	6/32 Screw (Electrical Box)	2
21	2-1240	Actuator Bar with Foam	1
22	1-1439	ACTUATOR BAR	1
23	6-1404	Foam Guard	1
24	6-0205	Hex HD. Bolt 1/4" NC x 1 1/2" LG.	1
25	1-2143	ACTUATOR EXTENTIONS	1
26	6-0027	Hex HD. Bolt 1/4" NC x 1 1/4" LG.	2
27	6-0741	Hex HD. Bolt 1/4"NC x 2" LG.	1
28	6-0069	Shoulder Bolt, 3/8" DIA. X 5/8" LG.	2
29	6-0294	HEX NUT, 5/16-18 UNC	6
30	1-1116	SAFETY CABLE PULLEY	2
31	6-1379	Wedge Anchor 3/4" x 5 1/2" LG. (c/w Washer & Nut)	10
32	6-2055	Power Pack, 208-230 V, 1 PH	1
33	6-0295	FLAT WASHER, 5/16" I.D.	4
34	6-0674	LOCK WASHER, 5/16 I.D.	4
35	6-0293	Hex Bolt, 5/16"-18UNC x 1" LG.	4
36	6-0248	Flat Washer, 1/2" ID SAE	16
37	6-0045	Hex HD Bolt, 1/2"-13UNC x 1" LG	8
38	6-0059	Lock Washer, 1/2"	16
39	6-0035	NUT, 1/2"-13 UNC, HEX	16
40	6-0291	Hex Bolt, 1/2"-13UNC X 1 1/2" LG.	8
41	0-0204	Safety Cover c/w Decals, Power Side	1
42	0-0203	Safety Cover c/w Decals, Slave Side	1
43	2-1580	CIRCULAR LIFT PAD	4
44	1-3280	CIRCULAR LIFT PAD - 3"	4
45	1-1113	SAFETY RELEASE HANDLE	1
46	6-1135	Plastic Knob	1
47	1-2040	HYDRAULIC HOSE (12FT)	1
48	2-1230	SHORT HYD. HOSE ASS'Y	1
49	6-1111	Serial Number Plate	1
50	4-1145-6	Short Arm RH (Stack Pad)	1
51	4-1146-6	Short Arm LH (Stack Pad)	1
52	4-1135-6	(LONG ARM) STACK PAD	2
53	1-3278	MOULDED RECTANGULAR	4
54	1-2618	ARM RESTRAINT GEAR	4
55	6-2059	HEX HD. BOLT 5/16-18 UNC x 1 1/4.	8
56	1-2914	ARM LOCK HANDLE WELDMENT	4
57	1-2942	HANDLE SPRING	4
58	6-3086	Spring Retainer Cap	4
59	6-2094	Lift Operations Decal	1
60	6-0536	TUBE CLAMP, 1/2"	3
61	6-1759	Electrical Cable Clip, 5/8" ID	3
62	1-2039	Equalizing Cable - 12 ft.	2
	1-2003	Equalizing Cable - 14 ft.	2
63	1-2058	Safety Release Cable	1
64	6-0008	Hex Bolt, 1/4" x 1" LG.	2

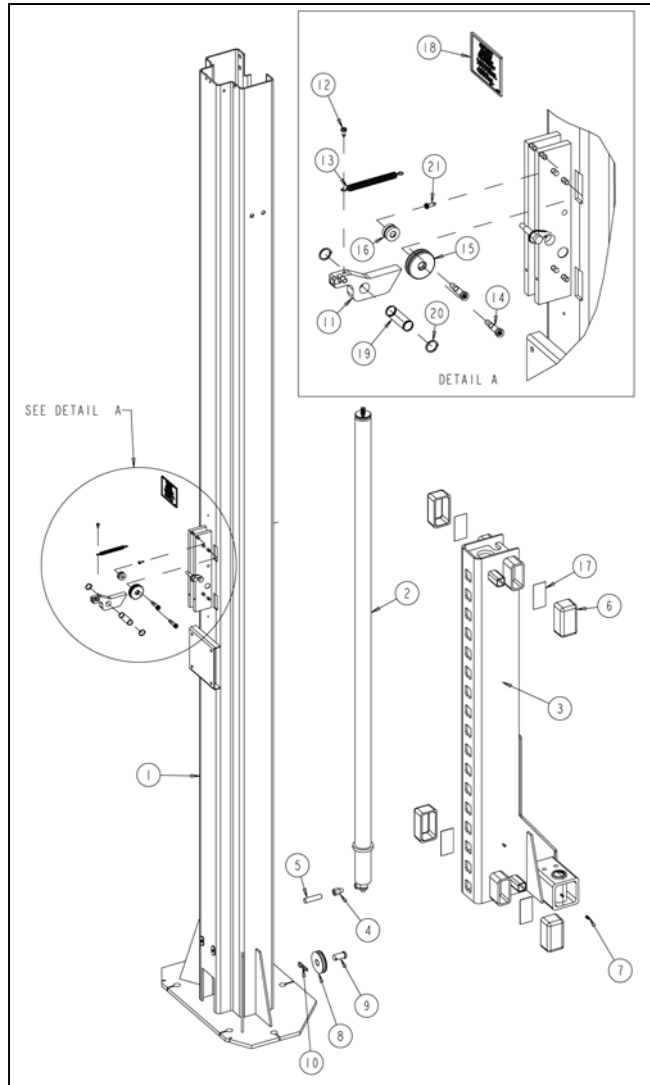

Item#	Part #	Description	Qty.
1	4-1012	TOWER WELDMENT POWER	1
2	3-0621	Hydraulic Cylinder Assembly (PATRIOT)	1
3	4-1162	FORMED CARRIAGE WELDMENT	1
4	6-1510	Flow Control	1
5	6-2095	Male Nipple, 1/4" NPT	1
6	2-0772	SLIDER BLOCK	4
7	6-0000	Grease Nipple	2
8	1-1898	PULLEY ASSEMBLY	1
9	1-1887	HEADED PIN	1
10	6-1841	Hitch Pin, 1/8" DIA.	1
11	2-1901	SAFETY DOG	1
12	6-0169	SELF-TAPPING SCREW, #10 X 3/8" LG	1
13	1-1115	SAFETY SPRING	1
14	6-0206	Shoulder Bolt, 3/8" DIA. X 1" LG.	2
15	1-0415	SAFETY CABLE PULLEY	1
16	1-1116	SAFETY CABLE PULLEY	1
17	1-2657	SHIM SLIDER BLOCK	6
18	6-1766	Capacity Decal	1
19	1-2337	SAFETY LOCK PIN	1
20	6-2445	Snap Ring 3/4" EXT	2
21	6-1134	SELF TAPPING SCREW, #12 X 1/2" LG	1

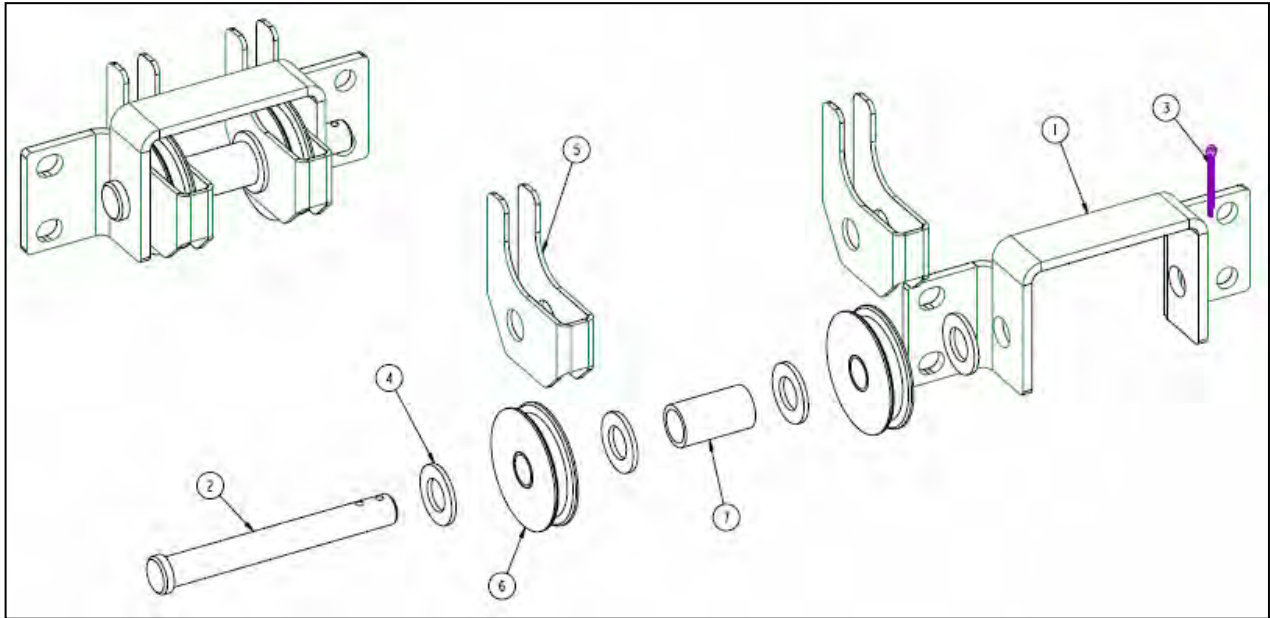

Item#	Part #	Description	Qty.
1	1-3063	CROSSMEMBER BRACKET COVER	1
2	1-3178	COMMON PULLEY PIN	1
3	6-0978	Cotter Pin, 1/8" DIA. X 1 1/2" LG	1
4*	6-0738	FLAT WASHER 3/4" SAE	4
5	1-3495	CABLE RETAINER	2
6	1-1898	PULLEY ASSEMBLY	2
7	1-1626	CROSSMEMBER PULLEY PIPE 1 3/4" LG	1

* Washer quantity may vary.

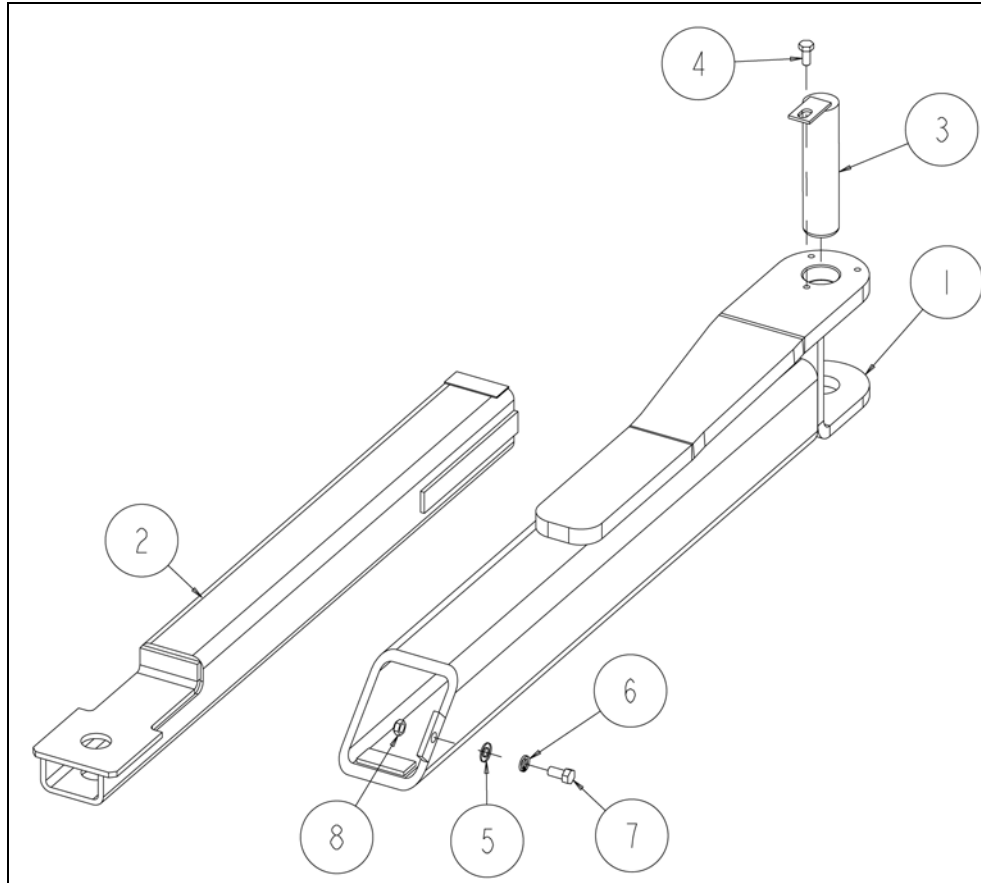

Item#	Part #	Description	Qty.
1	3-0920	ARM WELDMENT	1
2	3-0924	ASYM LONG INNER	1
3	2-1594	ARM PIN	1
4	6-0423	Hex Bolt, 5/16" - 18UNC x 3/4" LG.	1
5	6-0062	Flat Washer, 3/8" ID SAE	1
6	6-0058	LOCK WASHER, 3/8"	1
7	6-0030	Hex Bolt, 3/8 UNC x 3/4" LG.	1
8	1-2634	MOULDED RECTANGULAR	1
9	6-3369	3/8" Nylon Jam Nut	1

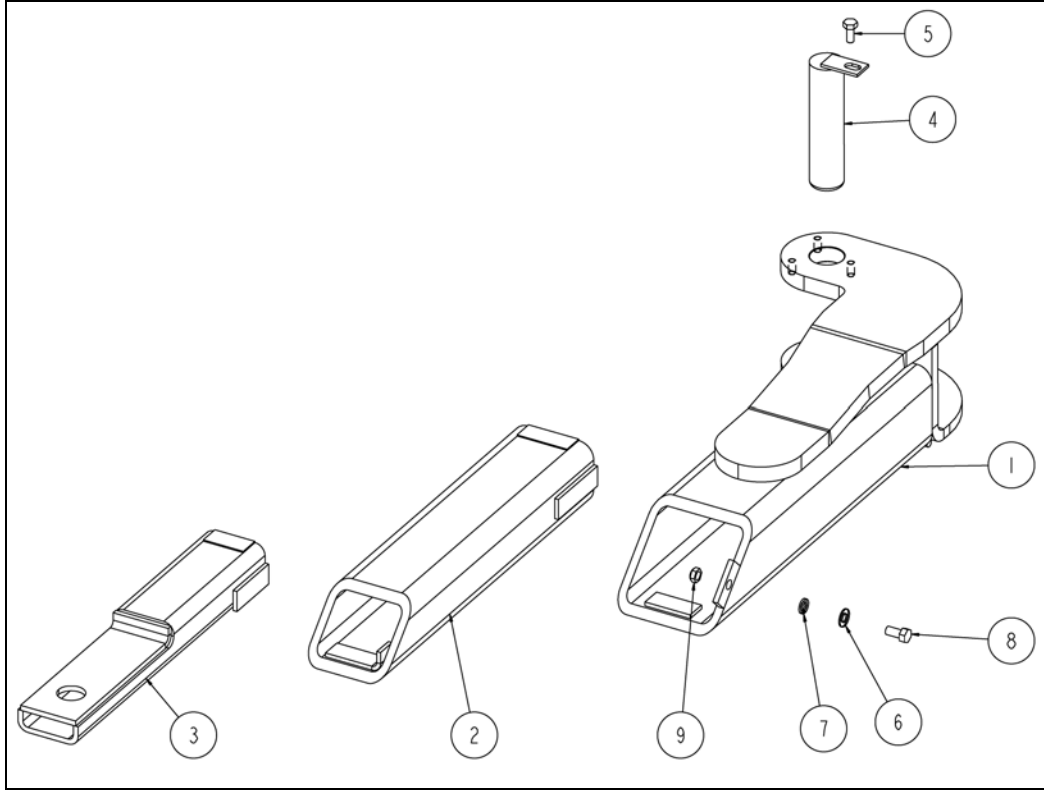

Item#	Part #	Description	Qty.
1	2-2300	OUTER TUBE WELDMENT LS	1
	2-2296	OUTER TUBE WELDMENT RH	1
2	2-2282	INTERMEDIATE ARM WELDMENT	1
3	2-2279	2-POST 2N1	1
4	2-1594	ARM PIN	1
5	6-0423	Hex Bolt, 5/16" - 18UNC x 3/4" LG.	1
6	6-0062	Flat Washer, 3/8" ID SAE	1
7	6-0058	LOCK WASHER, 3/8"	1
8	6-0030	Hex Bolt, 3/8 UNC x 3/4" LG.	1
9	6-3369	3/8" Nylon Jam Nut	1

1.1 HYDRAULIC SYSTEM

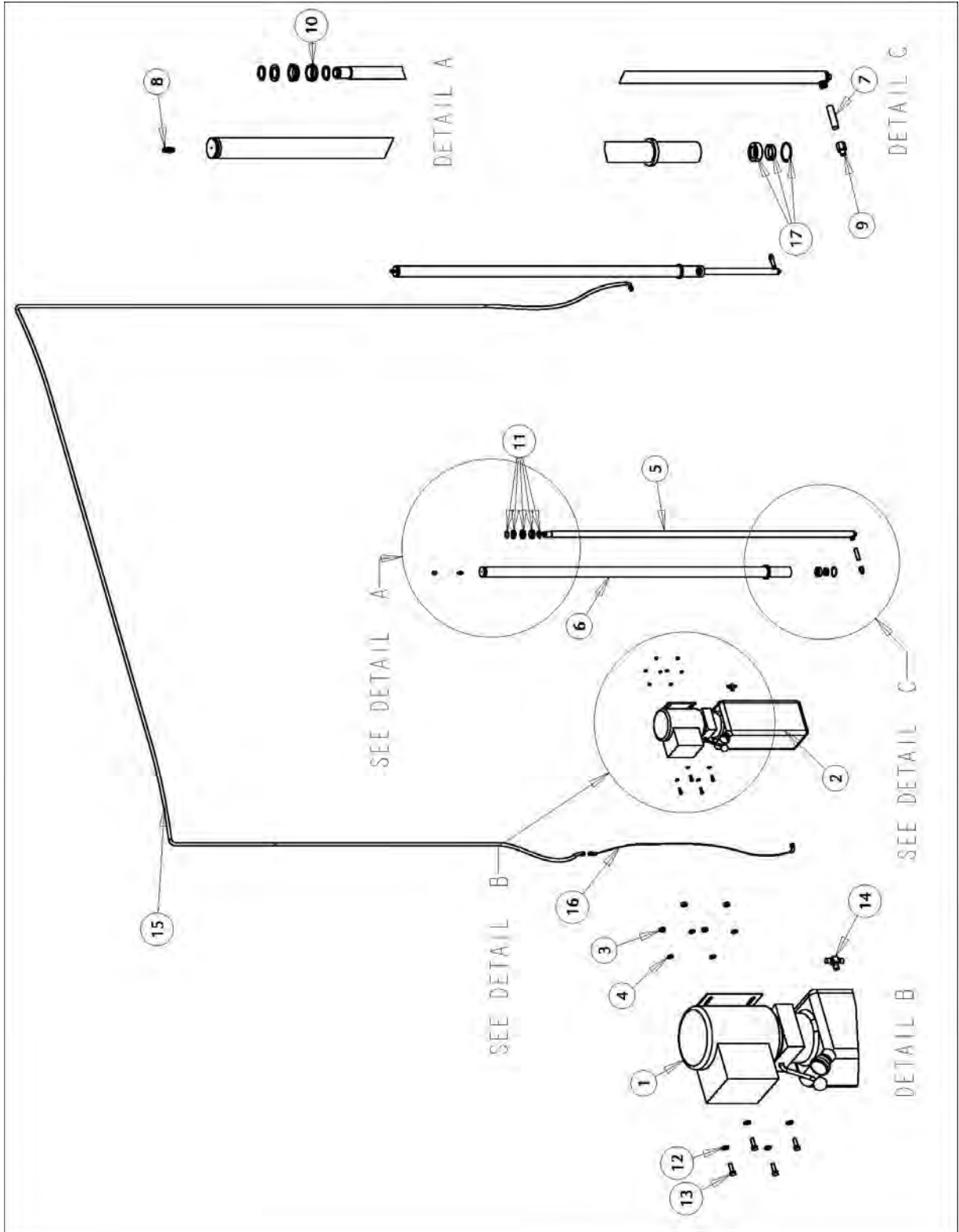

Item	Part #	Description	Qty
1	6-2055	Power Pack, 208-230V, 1 PH	1
	6-2665	Power Pack, 208-230V, 3 PH	
2	6-2094	"Lift Operation" Decal	1
3	6-0294	Hex Nut, 5/16"-18 UNC	4
4	6-0674	Lock Washer, 5/16" I.D.	4
5	2-1254	Piston Rod	2
6	2-125501	Cylinder Tube	2
7	6-2095	Male Nipple, 1/4" NPT	2
8	6-3666	Bleeder Valve	2
9	6-1510	Flow Control	2
10	1-1467	Piston	2
11	0-0337	Piston Seal Kit	2
12	6-0295	Flat Washer, 5/16" I.D.	4
13	6-0293	Hex Bolt, 5/16"-18 UNC x 1" LG.	4
14	6-1506	Branch Tee	1
15	1-2040	Hydraulic Hose (Long)	1
16	2-1230	Hydraulic Hose (Short)	1
17	0-0338	Gland Kit	2
	3-062101	Cylinder Assembly (Not INCL. Flow Control)	*
3PH Power Pack Includes the Following (<i>Not Shown</i>)			
*	6-1575	Contactorm Box	1
*	2-1130	Contactorm Bracket	1
*	1-1369	Cover Plate	1
*	6-0008	Hex Bolt, 1/4" -NC x 1" LG	2
*	6-0056	Lock Washer, 1/4"	4
*	6-0032	Hex Nut, 1/4" - NC	2
*	6-0094	Strain Relief	2
*	8-0287	Cable, 14/4	2 ft.

8.2 POWER PACK PARTS LIST:

NOTE: THERE ARE 2 TYPES OF POWER PACKS USED WITH THIS LIFT.

TYPE 1:

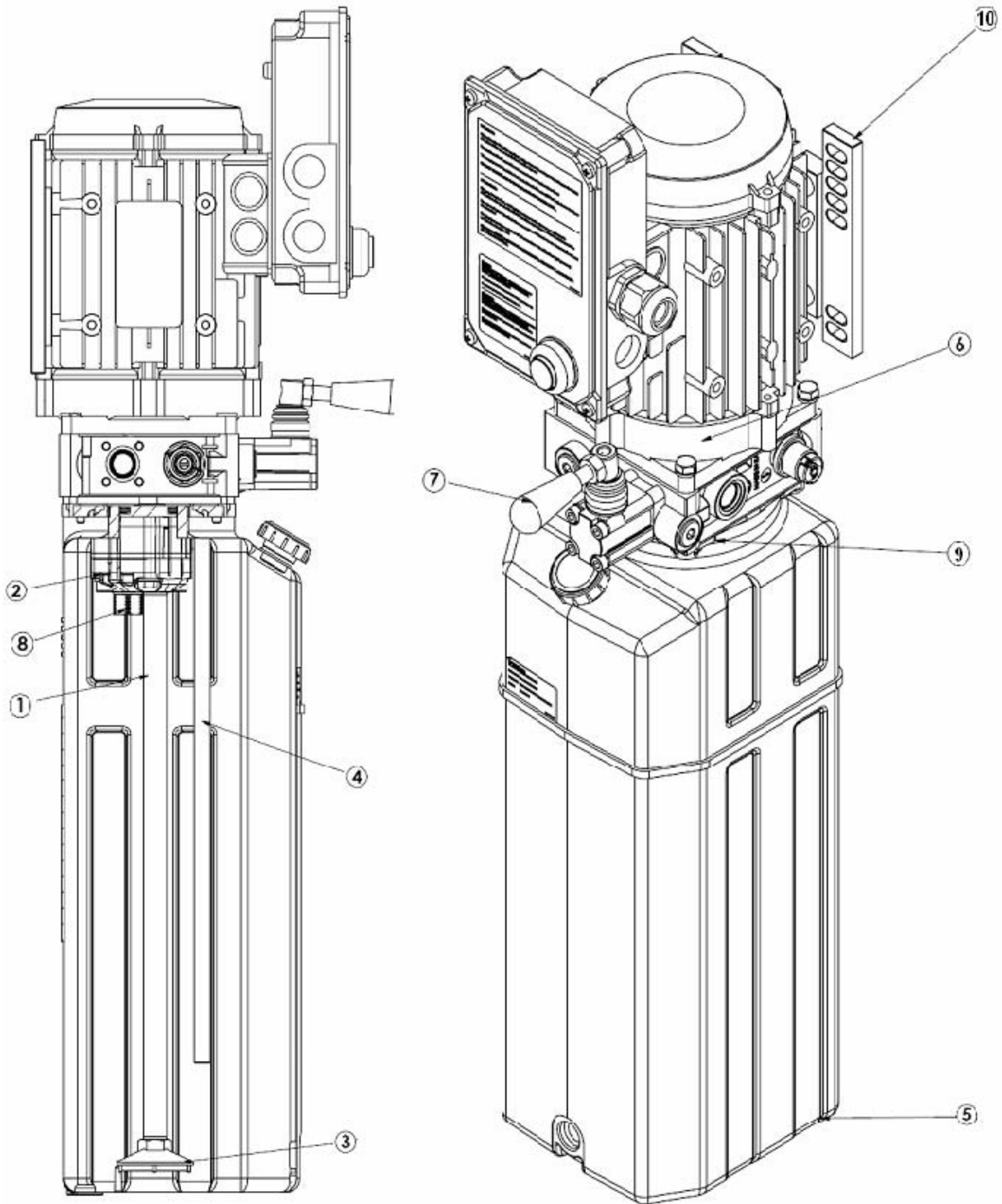

46.832.17.0004 230 V / 1 PH / 60 HZ

Item	Part #	Description	Qty
1	6-3442	PUMP 6.7G, 17 GEAR	1
2	6-3443	SUCTION PIPE 3/8"	1
3	6-3444	SUCTION FILTER 3/8" FEMALE 15 L/MIN	1
4	6-3445	RETURN PIPE	1
5	6-3446	PLASTIC TANK 12L	1
6	6-3447	MOTOR SHAFT COUPLING PUMP	1
7	6-3448	MANUAL VALVE	1
8	6-3452	START UP VALVE	1
9	6-3449	TANK BRACKET WITH SCREWS	1
10	6-3450	MOTOR BRACKETS	1
11*	6-3451	PUSH BUTTON WITH MICROSWITCH	1

***NOT SHOWN IN DIAGRAM**



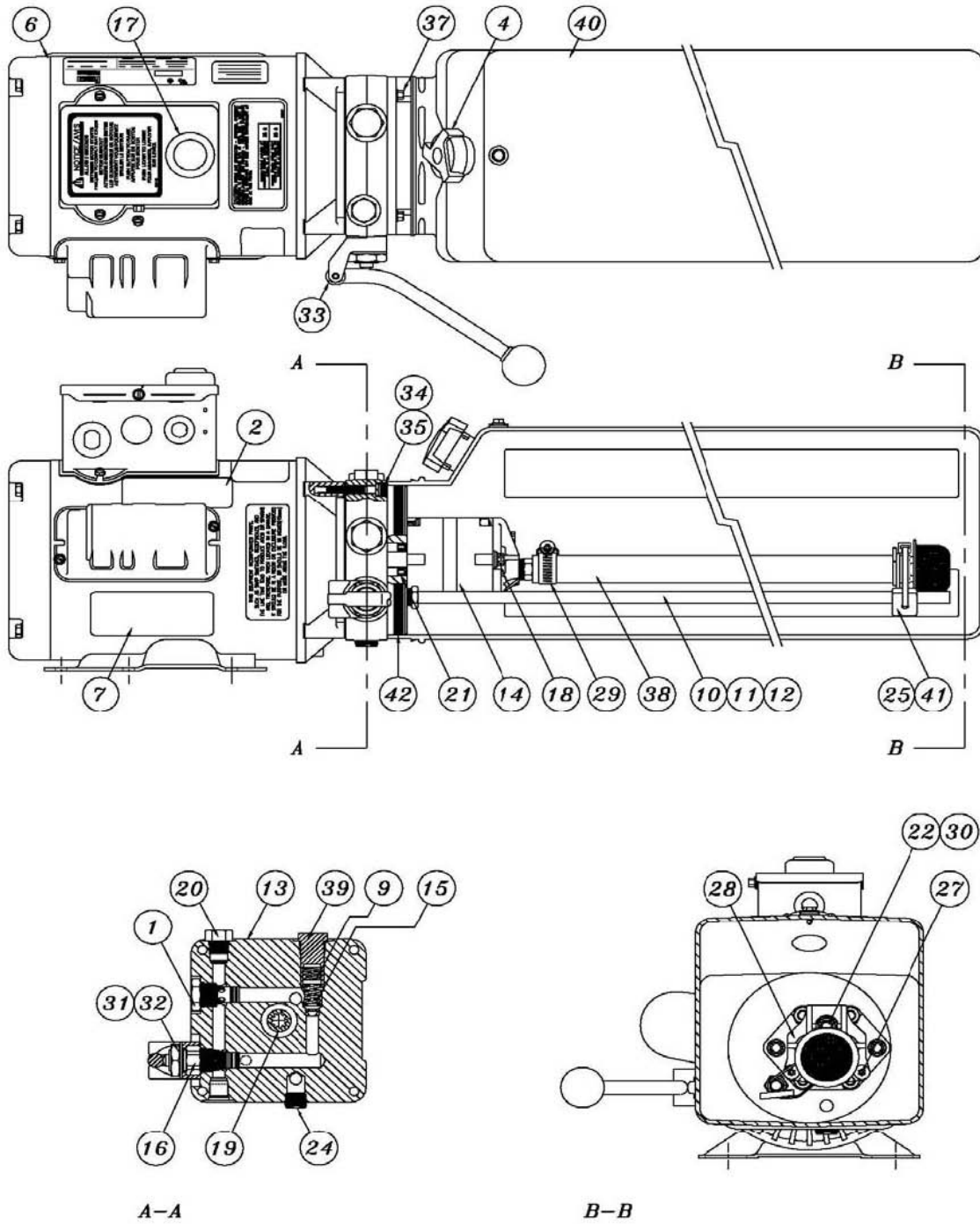







TYPE 2:

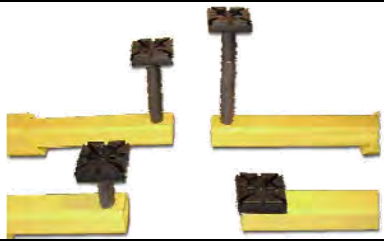

#6-2055 (AB-1381) 208-230V/1PH/60Hz
 #6-2665 (AD-1044) 208-230V/3PH/60Hz

Item	Part #	Description	Qty
1	6-1087	VALVE CARTRIDGE CHECK	1
2	6-2136	LABEL INSTALLATION AUTOHOIST	1
4	6-1376	BREATHER CAP & BLADDER	1
6	6-2139	MOTOR AC 208-230V. 2HP/1PH/60HZ, BLK	1
	6-1079	MOTOR AC 208-230V. 2HP/3PH/60HZ, BLK	1
7	6-2149	LABEL WARNING AUTOHOIST	1
9	6-2151	SPRING 0.480" X 0.063" X 0.42" COMP	1
10	6-2152	RETURN HOSE 3/8" OD X 21.5"	1
11	6-2153	COMPRESSION TUBE NUT	1
12	6-2154	COMPRESSION TUBE SLEEVE	1
13	6-2155	ENDHEAD UNIVERSAL AUTOHOIST	1
14	6-1958	PUMP ASS'Y 2.5 CC/REV. SHORT SLINE	1
15	6-1319	RELIEF ASSEMBLY FIXED 190 BAR	1
16	6-0880	VALVE CARTRIDGE RELEASE MANUAL	1
17	6-2156	WIRING ASSEMBLY AC 1PH FENNER	1
18	6-1090	BOLT 5/16"-24 X 3.00" TORX G8	2
19	6-0774	COUPLING SAE 9T-20/40 1.260"	1
20	6-2157	PLUMBING PLUG 9/16" SAE	1
21	6-2158	SEAL SHAFT 0.500" X 1.00" X 0.25"	1
22	6-2159	WASHER 0.338" X 0.625" X 0.060" STEEL	1
24	6-2161	PLUMBING PLUG 3/8" NPT	1
25	6-2162	PLUMBING MAGNET	1
27	6-2164	SCREW TAPTITE M6 X 1.0 12MM TORX	2
28	6-2165	COVER ASS'Y SUCTION	1
29	6-2166	PLUMBING CLAMP HOSE ADJ. INLET	1
30	6-1392	BOLT 5/16" – 18 X 1.00" SHCS	1
31	6-2167	NUT 3/4" –16 X 1" HEX X 0.25" STEEL	1
32	6-2168	WASHER 3/4" INT. TOOTH LOCK	1
33	6-0776	BRACKET – HANDLE ASS'Y REL BLACK	1
34	6-2169	BOLT M6 X 1.0 35MM SOC HD	4
35	6-2170	WASHER 1/4" LOCK HI-COLLAR	4
37	6-1091	BOLT #12-24 X 0.50" HEX HD WASHER	4
38	6-0786	PLUMBING ASS'Y INLET 17.24 (3)	1
39	6-1089	RELIEF VALVE CAP ASSEMBLY	1
40	6-1399	TANK PLASTIC 6.7 OS 22.50" BLK	1
41	6-1846	CABLE TIE 8" LONG WHITE	1
42	6-0875	O-RING 2-348 BUNA	1

9.0 AVAILABLE ACCESSORIES

Flip Pad Accessories				
	Poly Pad Adapter (set of 4)		High Lift Truck Extension Mid-Rise / 2-Post (set of 2)	
3000 lb max capacity each		2500 lb max capacity each		
Stack Pad Accessories				
	Stack Pad Adapter w/ Checker Plate Top (set of 4)		Stack Pad Ass'y w/ 3" & 6" Adapters (set of 1)	
3000 lb max capacity each		3000 lb max capacity each		
	1 1/2" Stack Pad Assembly Kit		4 1/2" Stack Adapter Kit	
3000 lb max capacity each		3000 lb max capacity each		
Common Accessories				
	Tool Tray Kit for 2-Post		Secondary Adapter Pad Kit (Used On Outer Arms)	
		3000 lb max capacity each		
	Air / Electric Service Station for 2-Post & 4-Post (90-110 psi 110 Volts Required)		Foam Door Protector Kit	
				24" Tower Extension

Accessories may not be available for all models. Contact supplier for availability and part numbers.

Max capacity is for 12,000 Lb Lifts. Do not exceed rated capacity of lift.