

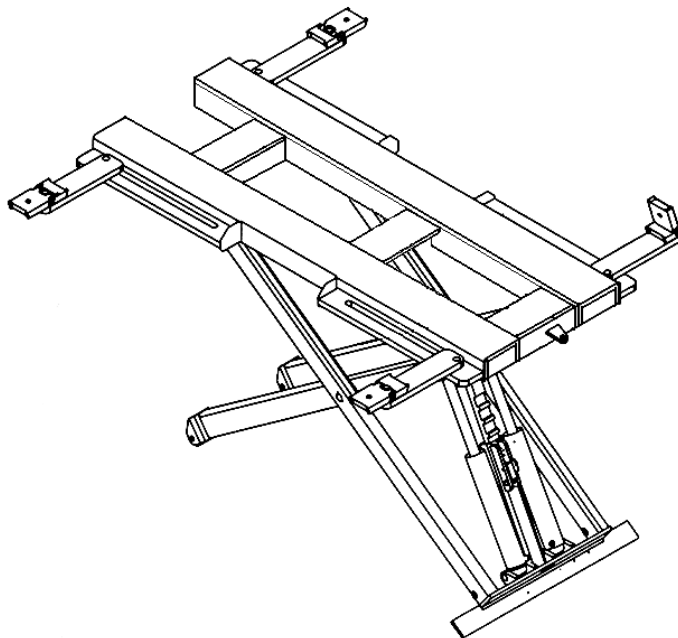

INSTALLATION and OPERATION MANUAL



MIDRISE

MODEL EELR300A /
EELR301A
6,500 LB. CAPACITY

**READ THIS INSTRUCTION MANUAL
THOROUGHLY BEFORE INSTALLING,
OPERATING, SERVICING OR
MAINTAINING THE LIFT. SAVE THIS
MANUAL.**

NOV 2007 REV.B

6-3295



Snap-On Tools Corporation

1-800-268-7959

TABLE OF CONTENTS

	PAGE
1. SAFETY INSTRUCTIONS	3
2. GENERAL SPECIFICATIONS.....	6
3. TOOLS REQUIRED	6
4. SHIPPING CONTENTS	6
5. INSTALLATION INSTRUCTIONS	7
5.1 UNPACKING PROCEDURE.....	7
5.2 ASSEMBLY INSTRUCTIONS.....	7
5.3 HYDRAULIC SYSTEM INSTALLATION.....	7
5.4 HYDRAULIC SYSTEM BLEEDING PROCEDURE.....	8
6. POSITIONING INSTRUCTIONS.....	8
6.1 FINAL CHECK OF ASSEMBLED LIFT	10
6.2 OPERATION TEST WITH VEHICLE	10
7. OPERATING INSTRUCTIONS.....	11
8. RECOMMENDED MAINTENANCE.....	12
8.1 DAILY MAINTENANCE	12
8.2 MONTHLY MAINTENANCE.....	12
9. SAFETY AWARENESS - AUTOMOTIVE LIFT INSTITUTE (ALI).....	13
10. PARTS MANUAL	14
10.1 MIDRISE MAIN FRAME ASSEMBLY	14
10.2 MIDRISE MAIN FRAME ASSEMBLY - PARTS LIST.....	15
10.3 HYDRAULIC CYLINDER ASSEMBLY	17
10.4 HYDRAULIC CYLINDER ASSEMBLY - PARTS LIST	18
10.5 POWER UNIT TOW CART	19
10.6 POWER UNIT TOW CART - PARTS LIST.....	20
10.7 POWER UNIT	21
10.8 POWER UNIT PARTS LIST	22
11. AVAILABLE ACCESSORIES	23

1. SAFETY INSTRUCTIONS

1. **CAUTION** When using this lift, basic safety precautions should always be followed, including the following:
2. Read all instructions in this manual and on the lift thoroughly before installing, operating, servicing or maintaining the lift.
3. The Midrise lift is designed for tire, brake and body work. It is not recommended for under vehicle work. If this type of work is being done, use (4) adequate capacity & height safety stands at (4) appropriate lifting point on the vehicle. Safety stands are available from your dealer.
4. Inspect your Midrise lift daily. Do not operate if it malfunctions or has damaged parts.
5. Never attempt to overload the lift. The manufacturer's rated capacity is shown on the serial number tag.
6. **DO NOT OVERRIDE** the automatic safety devices incorporated into the lift. Work on the vehicle only when the mechanical safety lock on the lift is activated.
7. Only trained and authorized personnel should operate the lift. Do not allow customers or bystanders to operate the lift or be in the work area.
8. Before driving over lift, position the arms to the drive-through position to ensure unobstructed clearance. Do not hit or run over arms as this could damage the lift and/or vehicle.
9. Position the lifting arms or rubber lift blocks to contact the vehicle manufacturer's recommended lifting points. Raise the lift until the pads contact the vehicle. Check pads for secure contact with the vehicle, then raise the lift to the mechanical safety working height.
10. Always keep the lift area free of obstruction and debris. Grease and oil spills should be cleaned up immediately.



NOTE: When positioning a vehicle over the lift, take time to center the load front to-rear and side-to-side. The removal or installation of some vehicle parts may cause a critical shift in the center of gravity and may cause the vehicle to become unstable.

11. Before driving over the lift make certain that the lift is completely in the down position, the lifting arms are in the stowed position and that the lifting pads are in the down position.

NOTE: DO NOT ATTEMPT TO OPERATE THE LIFT IF ANY PART IS NOT WORKING PROPERLY OR IF YOU HAVE NOT READ THE COMPLETE OPERATING INSTRUCTION MANUAL.

12. Never raise vehicle with passengers inside.
13. Before lowering check area for any obstructions.
14. Before removing the vehicle from the lift area, position the arms to the drivethru position to prevent damage to the lift and /or vehicle.
15. Do not remove hydraulic fittings while under pressure.

For additional safety instructions regarding lifting, lift types, warning labels, preparing to lift, vehicle spotting, vehicle lifting, maintaining load stability, emergency procedures, vehicle lowering, lift limitations, lift maintenance, good shop practices, installation, operator training and owner/employer responsibilities, please refer to “Lifting It Right” (ALI/SM) and “Safety Tips” (ALI/ST).

For additional instruction on general requirements for lift operation, please refer to “Automotive Lift-Safety Requirements For Operation, Inspection and Maintenance” (ANSI/ALI ALOIM).

Installation shall be performed in accordance with ANSO/ALI ALIS, Safety Requirements for Installation and Service of Automotive Lifts.



ATTENTION! This lift is intended for indoor installation only. It is prohibited to install this product outdoors. Operating environment temperature range should be 41 – 104 °F (5 – 40 °C). Failure to adhere will result in decertification, loss of warranty, and possible damage to the equipment.

+ 070126-Quadra-WLSIA01

SAFETY INSTRUCTIONS

If attachments, accessories or configuration modifying components that are located in the load path, affect operation of the lift, affect the lift electrical listing or affect intended vehicle accommodation are used on this lift and, if they are not certified for use on this lift, then the certification of this lift shall become null and void. Contact the participant for information pertaining to certified attachments, accessories or configuration modifying components.

www.autolift.org

©2007 by ALI, Inc.

ALI / WLSIA01

2. GENERAL SPECIFICATIONS

Maximum Capacity:	6,500 lbs.	2948 kg.
Maximum Lift Height:	48"	1219mm
Down Position Height:	4 7/8"	124mm
Shipping Weight:	1000 lbs.	454 kg.
Lift Time:	60 seconds	
Power Requirements:	115 V / 1 PH - 1 H.P. Motor	

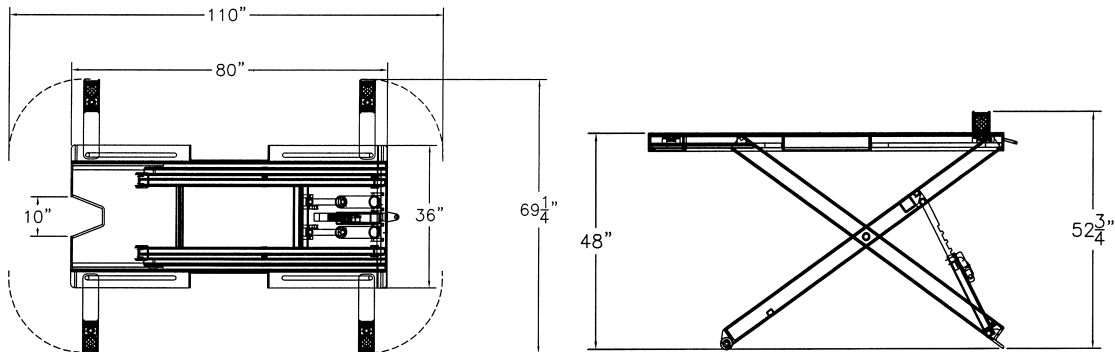

3. TOOLS REQUIRED

- 7/16" wrench
- 5/16" socket
- 5/8" wrench
- Side cutters

4. SHIPPING CONTENTS

The complete Midrise Lift is contained in two (2) packages. The main structure is packaged onto a shipping skid. The main structure comes fully assembled with lifting arms, main rollers and hydraulics. The remaining items come in an accessory box.

Accessory Box Contains:

- Power Pack and Tow Cart
- Required Hardware

Customer Care Kit: (inside accessory box)

- ALI manual "Lifting It Right"
- Automotive Lift Safety Tips
- Automotive Lift, Operation, Inspection and Maintenance manual
- "ALI" Quick Reference Guide
- Owner's manual

5. INSTALLATION INSTRUCTIONS

When lift arrives on site, please read the owner's manual and check for any freight damage. Also, check the contents to make sure no parts are missing before starting assembly.

5.1 UNPACKING PROCEDURE

Remove the metal strapping from the main structure package and slide the lift off the shipping skid. Open the accessory box and check the contents of the box.

NOTE: The Power Unit is already installed on the Tow Cart

5.2 ASSEMBLY INSTRUCTIONS

Install the handle onto the Power Unit Tow Cart. Align the hole and fasten together using the 1/4"-20UNC x 3/4" LG. hex head bolt and lock washer supplied. See Section 4.4 for safety pedal installation.

5.3 HYDRAULIC SYSTEM INSTALLATION

- 1.** Remove breather cap and add 1.1 gallon (4 liters) of ISO 32 (10 Hydraulic weight) hydraulic oil to the Power Unit.
- 2.** Reinstall the filler breather cap onto the Power Unit.
- 3.** Attach the 90° elbow from the hardware kit to the power unit by removing the red plastic cap.
- 4.** Connect the 3/8" NPT-M end of the 12ft. long hydraulic hose to the 3/8" 90 degree fitting that is already installed on the short hydraulic hose at the front of the lift.
- 5.** Install the 1/4" JIC female end of the 12' long hydraulic hose to the outlet fitting on the power pack.
- 6.** Plug the power pack utility cord into an approved 110 Volt outlet.

5.4 HYDRAULIC SYSTEM BLEEDING PROCEDURE

NOTE: Make certain lift area is clear from debris and any obstructions.

See section 6 for operating instructions.

1. Raise the lift a few inches off the floor. Check for any hydraulic leaks.
2. Lower the lift completely
3. Repeat this procedure.
4. Raise the lift to full height.
5. Attach the safety release pedal to the front angle with self tapping screws provided with the pedal on the outside (See exploded view on pg. 10).
6. Assemble linkage to pedal release bar with retainer provided in the hardware kit (#34 in exploded view on pg.10).
7. Press safety pedal to disengage safety mechanism.
8. Lower lift completely.
9. Raise and lower lift several times while checking for proper operation.
10. The hydraulic system is self bleeding

6. POSITIONING INSTRUCTIONS

NOTE: Please review ALI safety card attached to tow cart and inspect lift for mechanical fitness before using.

NOTE: Lifts must only be installed on “level” concrete floors, with a minimum thickness of three (3) inches. Concrete must have a minimum strength of 4,000 psi, and should be aged 30 days prior to installation.

1. To move lift, insert the lifting tab of the Power Tow Cart to the lifting bracket on the Mid-Rise. Tilt the cart back and move the Mid-Rise into position in the center of the work area or bay.
2. Remove the Power Tow Cart from the lifting bracket of the Mid-Rise and roll the cart to the front of the bay.
3. Plug the electric utility cord into an approved 110V outlet.
4. With the lifting arms in the stowed position, in line with the main frame, drive a vehicle over the lift.

NOTE: When positioning a vehicle over the lift, take time to equalize the load front-to-rear and side-to-side.

NOTE: The Midrise lift may be used as a frame contact lift or as a platform lift, depending on the type of vehicle being worked on and the manufacturer recommended lifting points for that vehicle.

NOTE: Obstructions hanging down from the vehicle may be damaged when lifting. Always check between the vehicle and the contact points on the lift.

5. When in use as a frame contact lift, slide the lifting arms freely along the length of the arm support to the desired position. The flip up lift pads have three (3)

positions, select and position as recommended to contact the correct lifting points for this vehicle.

NOTE: Some vehicles may require optional riser adapters to reach the manufacturer's recommended lift points.

When in use as a platform lift, move the lifting arms into the stowed position, in line with the main frame. Position the four (4) rubber lifting blocks on top of the platform.

NOTE: Leave additional room for any desired aisle or work area. Recommended clearance around lift is three feet (3 ft). Recommended overhead clearance is a minimum twelve feet (10 ft) ceiling providing 4 feet for the maximum lift height and 6 feet for the supported vehicle. For vehicles taller than 6 feet it is recommended that the user provides additional overhead clearance or a shut off mechanism to stop the lift from raising the vehicle too high. Ensure clearance conforms to local building and fire codes.

6.1 FINAL CHECK OF ASSEMBLED LIFT

1. Check for hydraulic leaks. _____
2. Check that LOCTITE has been applied to all hardware where required. _____
3. Check adjustment of safety release
4. Check all fasteners, tighten if necessary. _____
5. Operate lift to full stroke then lower to ground while checking for proper functionality. _____
6. Ensure Customer Care Kit is complete and given to operator. _____
 - a. Operation Manual _____
 - b. ANSI / ALI Lift It Right Manual _____
 - c. ANSI / ALI Safety Tip Card _____
 - d. ANSI / ALI ALIS Safety Requirements for Installation and Service of Automotive Lifts _____
 - e. ANSI / ALI Quick Reference Guide _____
7. Train end user on operation of lift. _____

6.2 OPERATION TEST WITH VEHICLE

1. Lower lift to ground.
2. Drive vehicle on to lift and locate the arms as per the “Lift it Right” manual.
3. Raise lift to and lower onto 3-4 lock positions during full rise to ensure all locks are working correctly.
4. Check lowering speed and smooth decent rate.
5. Lower lift to ground and drive vehicle off lift.

If any problems occur during the final checkout or operation of the lift please contact customer service at 1-800-268-7959

7. OPERATING INSTRUCTIONS

1. Raise the lift by pressing the “UP” button on the front face of the Power Unit.
2. Continue raising the lift until the mechanical safety “CLICKS” into position. The safety has five positions between lift heights of 24” and 48”. Always lower the lift in order to fully engage the mechanical safety lock when the desired working height is reached.
3. To lower the lift; first disengage the safety by raising the lift 1” and pressing the safety release pedal. Next, push the lever on the Power Unit.
4. Lower the lift to the fully down position.

NOTE: The safety mechanism automatically resets when the lift is raised again.

5. Reposition the lifting arms to the stowed position and/or remove the rubber lift blocks.
6. Remove the vehicle by driving forward or reverse off the lift.
7. If the Midrise lift will not be used for any given period of time unplug the power cord.

8. RECOMMENDED MAINTENANCE

8.1 DAILY MAINTENANCE

- 1.** Check general operation of lift.
- 2.** Check operation of mechanical safety lock engaging and disengaging.
- 3.** Check condition of floor in roller area for cracks and debris.
- 4.** Check position of hydraulic hose, ensure that a vehicle positioned on the lift or the lift itself will not damage the hose.
- 5.** Check condition of electrical cord before plugging into an approved 110V power supply.







8.2 MONTHLY MAINTENANCE





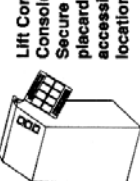

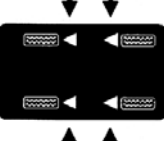
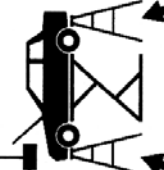
- 1.** Check all hydraulic hoses, fittings and cylinders for leaks.
- 2.** Check level of oil in power unit reservoir when unit is in the lowered position. Add more if required.
- 3.** Check and lubricate safety release device and glide blocks.
- 4.** Inspect 110V plug end and cable.
- 5.** Inspect rollers on tow cart and main structure.
- 6.** Inspect lift area for debris and concrete condition.

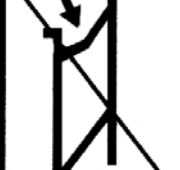
9. SAFETY AWARENESS - AUTOMOTIVE LIFT INSTITUTE (ALI)

SAFETY WARNING LABELS FOR HINGED FRAME ENGAGING LIFTS Lift Owner/User Responsibilities:

- A. This Safety Warning placard **SHALL** be displayed in a conspicuous location in the lift area.
- B. Use one of the mounting arrangements illustrated on back of this placard.
- C. These Safety Warning labels supplement other documents supplied with the lift.
- D. Be certain all lift operators read and understand these labels, operating instructions and other safety related information supplied with the lift.

<p>CAUTION</p>  <p>Lift to be used by trained operator only.</p>	<p>Power Unit: Secure placard near lift controls.</p>  <p>Lift Control Console: Secure placard in an accessible location.</p> 	<p>The messages and pictographs shown are generic in nature and are meant to generally represent hazards common to all automotive lifts regardless of specific style. Funding for the development and validation of these labels was provided by the Automotive Lift Institute, PO Box 33116 Indianapolis, FL 33203. They are protected by copyright. Set of labels may be obtained from ALI or its member companies. © 1992 by ALI, Inc. ALI#WJ000044</p>
<p>CAUTION</p>  <p>Authorized personnel only in lift area.</p>	<p>CAUTION</p>  <p>Use vehicle manufacturer's lift points.</p>	<p>CAUTION</p>  <p>Always use safety stands when removing or installing heavy components.</p>
<p>SAFETY INSTRUCTIONS</p>  <p>Read operating and safety manuals before using lift.</p>	<p>SAFETY INSTRUCTIONS</p>  <p>Proper maintenance and inspection is necessary for safe operation.</p>	<p>SAFETY INSTRUCTIONS</p>  <p>Do not operate a damaged lift.</p>

<p>WARNING</p>  <p>Position vehicle with center of gravity midway between adapters.</p>	<p>WARNING</p>  <p>Remain clear of lift when raising or lowering vehicle.</p>	<p>WARNING</p>  <p>Keep feet clear of lift while lowering.</p>
<p>WARNING</p>  <p>Clear area if vehicle is in danger of falling.</p>	<p>WARNING</p>  <p>Avoid excessive rocking of vehicle while on lift.</p>	<p>WARNING</p>  <p>Keep clear of pinch points when lift is moving.</p>

10. PARTS MANUAL
10.1 MIDRISE MAIN FRAME ASSEMBLY

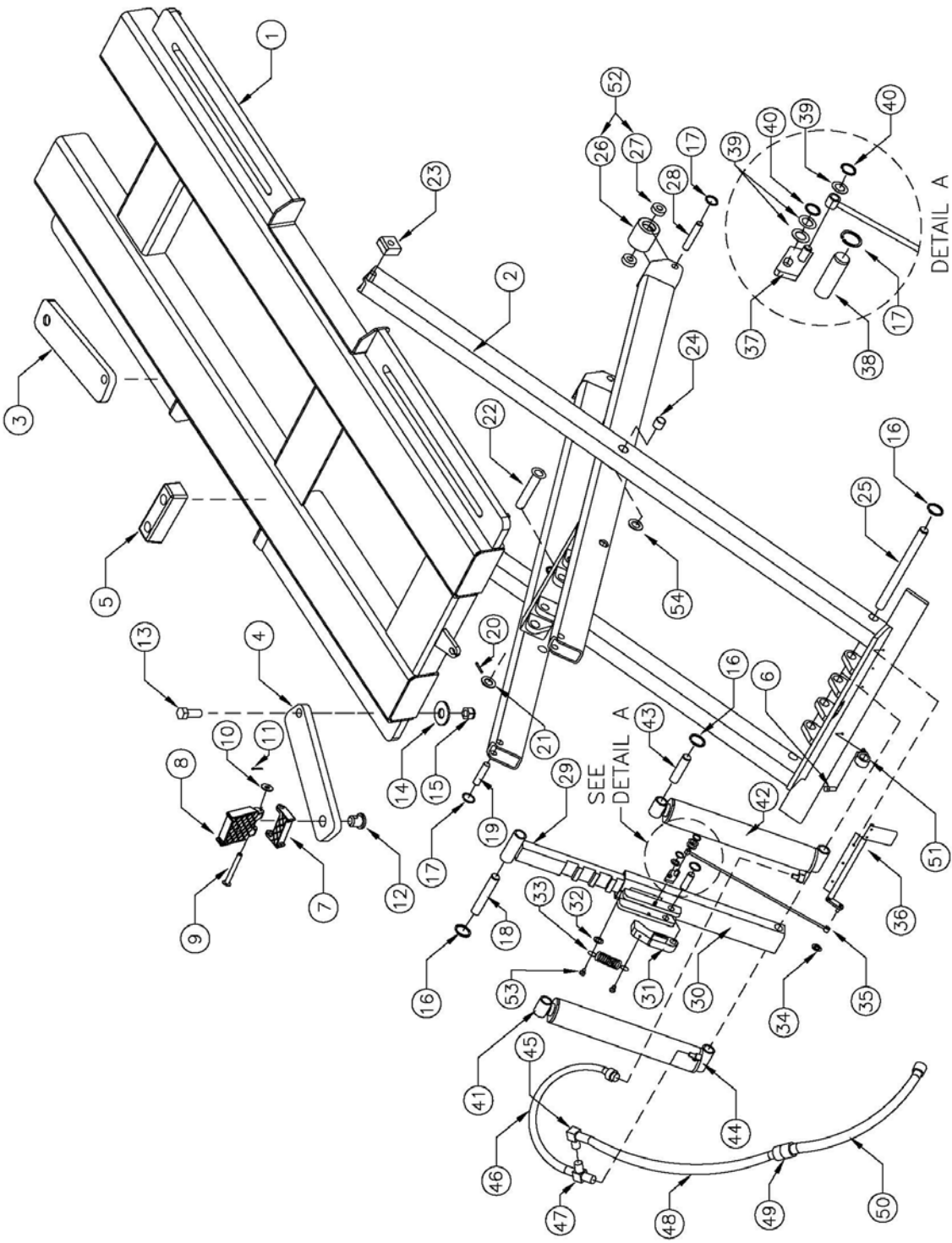

10.2 MIDRISE MAIN FRAME ASSEMBLY - PARTS LIST

ITEM NO.	QTY.	DESCRIPTION	PART NO.
1	1	DECK ASSEMBLY	4-1147
2	1	SCISSOR ASSEMBLY	4-0943
3	2	ARM (RIGHT FRONT / LEFT REAR)	2-1809
4	2	ARM (LEFT FRONT / RIGHT REAR)	2-1808
5	4	RUBBER BLOCK	6-1074
6	4	SELF TAPPING SCREW #12 X ½" LG.	6-1134
7	4	LOW ADAPTER	3-0583
8	4	HIGH ADAPTER	3-0582
9	4	CENTER PIN	1-1099
10	4	FLAT WASHER ½" I.D.	6-0063
11	4	COTTER PIN 1/8" X 1 ½" LG.	6-0267
12	4	ADAPTER PIN	1-1091
13	4	ARM BOLT	1-1076
14	4	FLAT WASHER 1" I.D.	6-1106
15	4	LOCK NUT 1"- 8 UNC	1-1385
16	8	EXTERNAL SNAP RING 1"	6-0581*
17	10	EXTERNAL SNAP RING ¾"	6-2445*
18	1	SAFETY UPPER PIN	1-2342
19	2	HINGE PIN	1-2336
20	2	SPRING PIN 3/16" X 1 ¼" LG.	6-0749
21	2	KEEPER WASHER	1-0725
22	2	SCISSOR PIN	1-2373
23	2	GLIDE BLOCK	1-2335
24	8	FIBRE WOUND BEARING	6-1620
25	1	LOWER CYLINDER MOUNTING PIN	1-2343
26	2	ROLLER	1-0807
27	4	BEARING	6-0751
28	2	ROLLER PIN	1-2338
29	1	SAFETY RACK	2-1821*
30	1	SAFETY OUTER	3-0844*
31	1	SAFETY LOCK	1-2371*
32	1	FLAT WASHER #10 I.D.	6-0816*
33	1	SPRING	1-1115*
34	1	RETAINER 5/16"	6-2470*
35	1	PUSHROD	2-1822*
36	1	SAFETY PEDAL ASSEMBLY	2-1823
37	1	SAFETY RESET	1-2370*
38	1	SAFETY LOCK PIN	1-2337*
39	3	FLAT WASHER 21/64" ID x 19/32" OD x 0.062	6-3265*
40	2	EXTERNAL SNAP RING 5/16"	6-2449*
41	1	HYDRAULIC CYLINDER (P.S.)	3-0839
42	1	HYDRAULIC CYLINDER (D.S.)	3-0838
43	2	UPPER CYLINDER MOUNTING PIN	1-2340
44	2	FLOW CONTROL 90° ELBOW	6-1638
45	1	90° SWIVEL ELBOW	6-2467
46	1	HYDRAULIC HOSE 13"	1-2368
47	1	SWIVEL TEE	6-2466

ITEM NO.	QTY.	DESCRIPTION	PART NO.
----------	------	-------------	----------

48	1	HYDRAULIC HOSE 19" LG.	1-0858
49	1	3/8" NPT-F STRAIGHT HYDRAULIC STEEL	70531931
50	1	HYDRAULIC HOSE 12'	2-0602
51	1	TUBE CLAMP 1/2"	6-0536
52	2	ROLLER ASSEMBLY KIT (W/ ROLLER	0-0191
53	2	SELF TAPPING SCREW #10 X 3/8" LG.	6-0169*
54	4	THRUST WASHER	6-0807

NOTE: ITEMS MARKED WITH (*) ARE PART OF *SAFETY ASSEMBLY KIT # 0-0900.*

10.3 HYDRAULIC CYLINDER ASSEMBLY

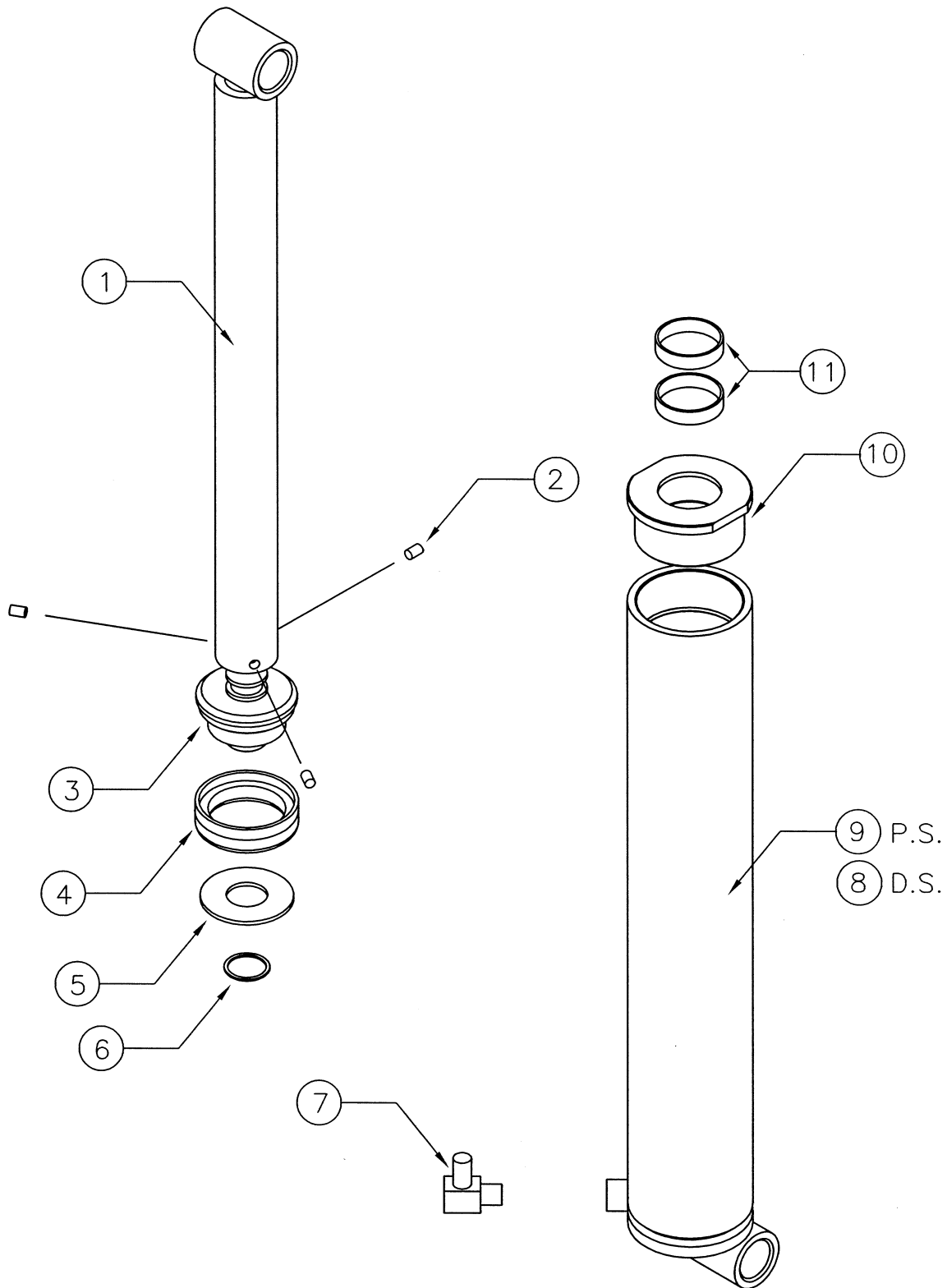

10.4 HYDRAULIC CYLINDER ASSEMBLY - PARTS LIST

ITEM NO.	QTY.	DESCRIPTION	PART NO.
1	1	PISTON TUBE WELDMENT	2-1827
2	3	SET SCREW	6-0580
3	1	PISTON	2-1806
4	1	PISTON SEAL KIT	6-2915*
5	1	KEEPER WASHER	1-1148*
6	1	EXTERNAL SNAP RING	6-0581*
7	1	FLOW CONTROL 90° ELBOW	6-1638
8	1	CYLINDER TUBE (D.S.)	2-1828
9	1	CYLINDER TUBE (P.S.)	2-1829
10	1	GLAND	1-2345
11	2	WEAR RING	6-2093

NOTE: PART NUMBERS MARKED WITH AN ASTERIX (*)
ARE CONTAINED IN REPAIR KIT NUMBER 0-1287 (1 CYL.)
AND 0-1288 (2 CYL.)

10.5 POWER UNIT TOW CART

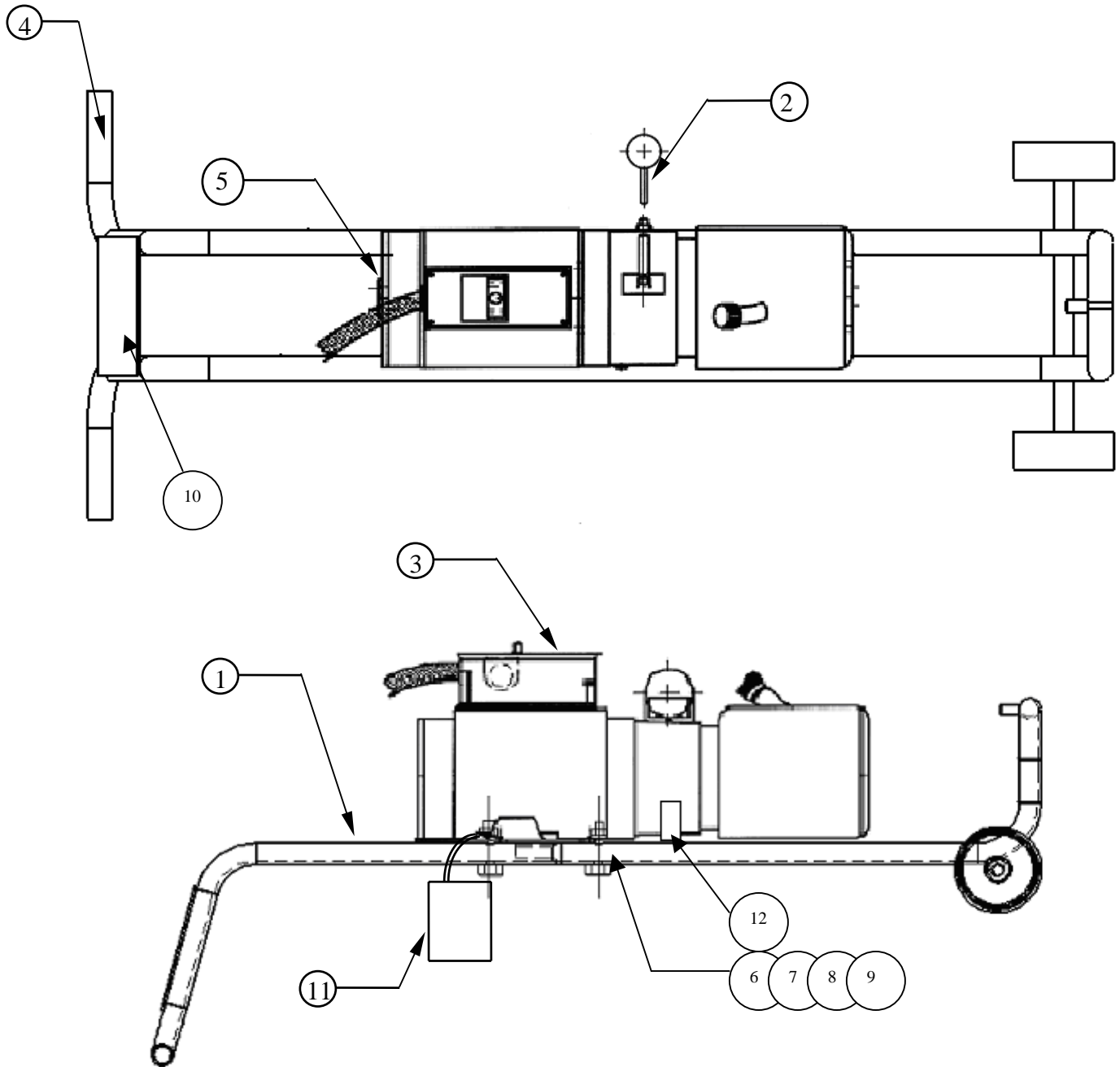

10.6 POWER UNIT TOW CART - PARTS LIST

ITEM NO.	QTY.	DESCRIPTION	PART NO.
1	1	STAND (WITH WHEELS AND HUB CAP NUTS)	4-0207-01
	2	4" DIA PLASTIC WHEELS	6-0753
	2	HUBCAP NUTS	6-1833
2	1	ADAPTER-MACHINED W/ ORIFICES (.035"DIA)	1-1063
3	1	POWER PACK 115/230V 1PH 60HZ 1 HP	6-2249
4	2	GRIP HANDLE	6-0758
5	1	PLUG	6-1711
6	4	HEX BOLT 1/4"-20UNC	6-0028
7	4	LOCKWASHER 1/4" I.D.	6-0056
8	4	FLAT WASHER 5/16" I.D.	6-0295
9	4	HEX NUT 1/4"-20UNC	6-0032
10	1	DECAL "OPERATING INSTRUCTIONS"	6-2469
11	1	ALI PLACARD	6-0990
12	1	90° ELBOW	6-1093
*	1	COMPLETE TOWCART W/ ELECTRIC POWER	4-0955

** SEE NEXT PAGE FOR THE POWER UNIT ASSEMBLY

10.7 POWER UNIT

#6-2249 (AB-1425) 115-230V/1PH/60Hz

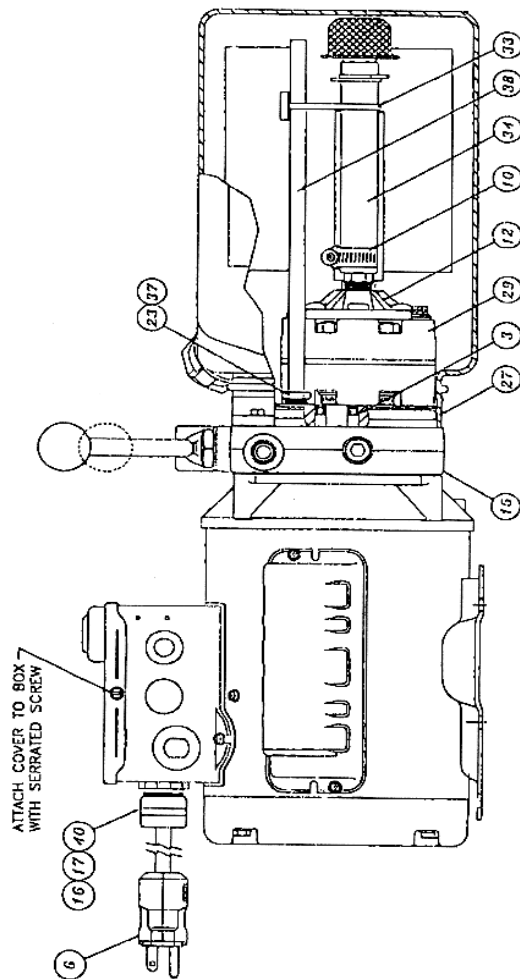
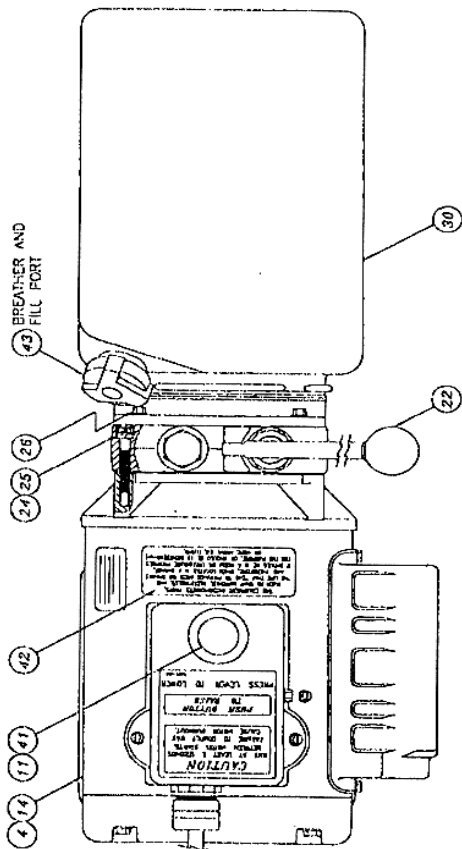
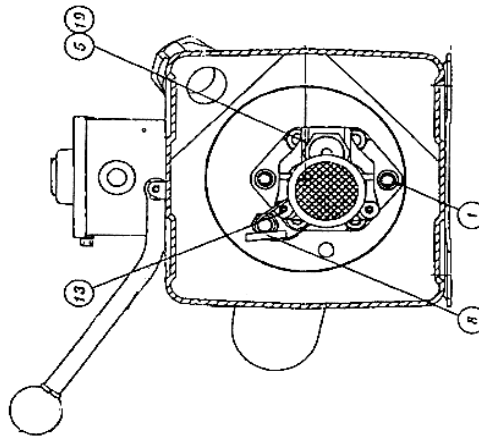
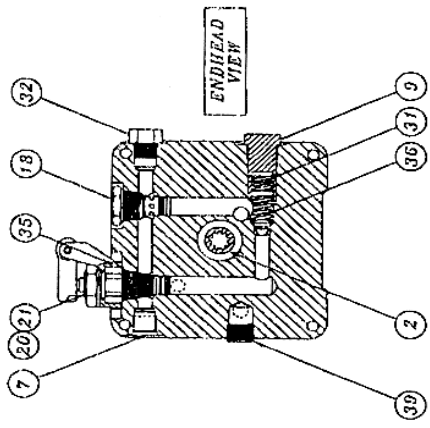

10.8 POWER UNIT PARTS LIST

#6-2249 (AB-1425) 115-230V/1PH/60Hz

ITEM	QTY.	DESCRIPTION	PART #
1	2	BOLT 5/16"-24 x 2 3/4" TORX G8	6-2298
2	1	COUPLING SAE 9T-20/40 1.260"	6-0774
3	1	SEAL SHAFT 0.500" x 1.00" x 0.25"	6-2158
4	1	MOTOR AC PSC #613000 115/230 1 HP 1PH BLK	6-2299
5	1	WASHER 0.338" x 0.625" x 0.060" STEEL	6-2159
6	1	CORDSET 16/3 SJO 8FT 115V PLUG	6-2300
7	1	PACKAGE PLUG 9/16" SAE	6-2301
8	1	PLUMBING MAGNET	6-2162
9	1	RELIEF VALVE CAP ASSEMBLY	6-1089
10	1	PLUMBING CLAMP HOSE ADJ INLET	6-2166
11	2	ELECTRIC STAKON NUT	6-2302
12	1	COVER ASS'Y SUCTION	6-2165
13	2	SCREW TAPTITE M6x1.0 12MM TORX	6-2164
14	1	NAMEPLATE, SERIAL	
15	1	ENDHEAD UNIVERSAL AUTOHOIST	6-2155
16	1	ELECTRIC CORD GRIP 3/4" NPT	6-2303
17	1	ELECTRIC PIPENUT 3/4"	6-2304
18	1	VALVE CARTRIDGE CHECK	6-1087
19	1	VALVE LOAD DELAY	6-2305
20	1	NUT 3/4"-16 x 1"HEX x 0.250 STEEL	6-2167
21	1	WASHER 3/4" INT. TOOTH LOCK	6-2168
22	1	BRACKET HANDLE ASS'Y REL BLACK	6-0776
23	1	COMPRESSION TUBE NUT	6-2153
24	4	BOLT M6 x 1.0 35MM SOC HD	6-2169
25	4	WASHER 1/4" LOCK HI-COLLAR	6-2170
26	4	BOLT #12-24 x .50 HEX WSHRHD	6-1091
27	1	O-RING 2-348 BUNA	6-0875
28	1	COVER ASSY SUCTION	6-2165
29	1	PUMP ASS'Y 0.8 SHORT SPLINE	6-2306
30	1	TANK PLASTIC 6.7 CT 11.0" BLACK	6-2307
31	1	SPRING 0.480" x 0.063" x 0.42" COMP	6-2151
32	1	PLUMBING PLUG 5/16" SAE	6-2157
33	1	CABLE TIE 8" LONG WHITE	6-1846
34	1	PLUMBING ASS'Y INLET 6.61 (3)	6-2308
35	1	VALVE CARTRIDGE RELEASE MANUAL	6-0880
36	1	RELIEF ASSEMBLY FIXED 260 BAR	6-1326
37	1	COMPRESSION TUBE SLEEVE	6-2154
38	1	RETURN HOSE 3/8" OD x 10.0"	6-2310
39	1	PLUMBING PLUG 3/8"NPT	6-2161
40	2	ELECTRIC REDUCER WASHER	6-2311
41	1	WIRING ASSEMBLY AC 1PH FENNER	6-2156
42	1	LABEL INSTALLATION AUTOHOIST	6-2136
43	1	BREATHER CAP & BLADDER	6-1376

11. AVAILABLE ACCESSORIES

	<p>Poly Pad Adapter (set of 4)</p>		<p>High Lift Truck Extension Mid-Rise / 2-Post (set of 2)</p>
<p>3000 lb max capacity each</p>		<p>2500 lb max capacity each</p>	
	<p>Frame Contact Lift Blocks (set of 4)</p>		

Accessories may not be available for all models. Contact supplier for availability and part numbers.