

# WHEELFREE TWIN POST 8021

681.

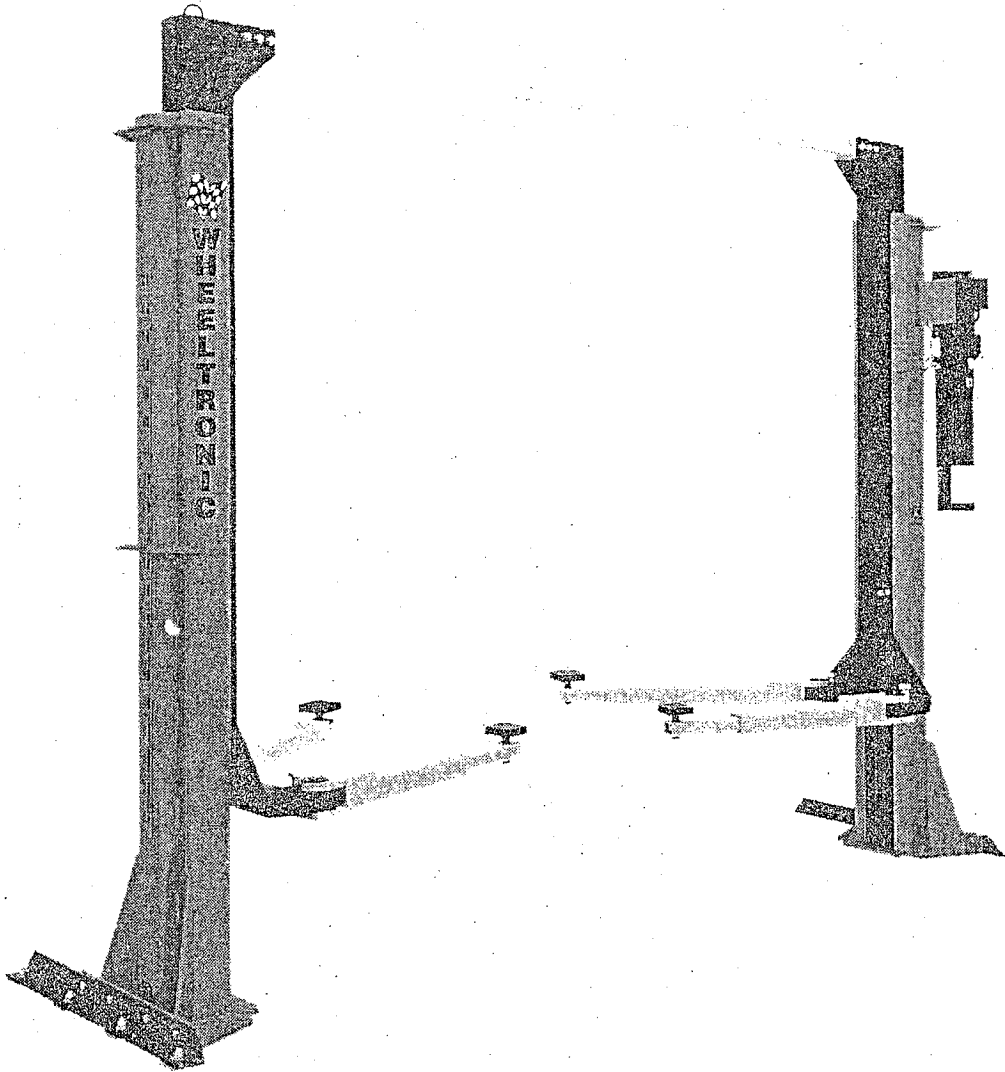

## INSTALLATION AND OPERATION MANUAL

(8000lb)

**SAVE THESE INSTRUCTIONS  
READ ALL INSTRUCTIONS**

AUTOMOTIVE SERVICE EQUIPMENT

**WHEELFREE LTD.**

6500 Millcreek Drive., Mississauga, Ontario, L5N 2W6

Tel: (905) 826-8600 • Fax: (905) 826-7800

6-0605

6 0605

# TABLE OF CONTENTS

91-12

<b>1. SPECIFICATIONS</b>	<b>1</b>
<b>2. CONTENTS</b>	<b>1</b>
<b>3. TOOLS REQUIRED</b>	<b>2</b>
<b>4. INSTALLATION INSTRUCTIONS</b>	<b>2</b>
-Unpacking Procedure	
-Tower Installation and Levelling	
-Installation of Arms	
-Hydraulic System Installation	
-Hydraulic System Bleeding Procedure	
-Shimming of Remaining Tower	
-Safety Cable Adjustment	
-Installation of Safety Covers	
-Hydraulic Levelling	
<b>5. SAFETY AND OPERATING INSTRUCTIONS</b>	<b>17</b>
<b>6. MAINTENANCE INSTRUCTIONS</b>	<b>18</b>
<b>7. SPARE PARTS</b>	<b>20</b>

## 1. MODEL 8020 / 8021 SPECIFICATIONS

- \* Capacity - 8,000 lbs.
- \* Overall width - 134"
- \* Width between columns - 115"
- \* Drive-through width - 95"
- \* Overall extended height - 159"
- \* Drive-through clearance - 84"
- \* Height of lift pads, lowered - 4 1/2"
- \* Height of lift pads, raised - 6 1/2"
- \* Maximum lifting height - 78 1/2"
- \* Lift time - 45 seconds
- \* Front arm extension - 25" to 40"
- \* Rear arm extension - 35" to 56"
- \* Motor - 2HP, 220V, single phase
- \* Shipping weight 1970 lbs.

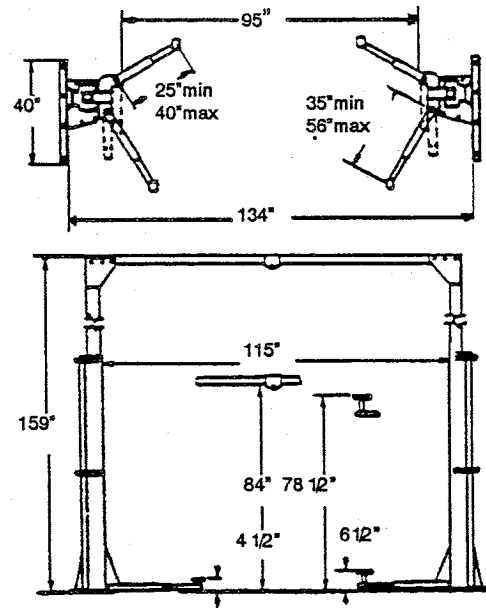

## 2. CONTENTS

The complete Model 8020 Twin Post Lift is contained in two (2) packages:  
The main structural components are packed in an "angle iron frame", the remaining items come in an accessory box.

### Main Structural Components:

- 1 - left side tower and carriage assembly
- 1 - left side carriage cover
- 1 - right side tower and carriage assembly
- 1 - right side carriage cover
- 1 - cross member
- 1 - cross over hydraulic line (2pc.)

### Accessory box items:

- 2 - short front telescopic arms c/w arm pins
- 2 - long rear telescopic arms c/w arm pins
- 4 - arm riser pads
- 2 - tower stabilizer legs (3 x 3 x 40" angle)
- 4 - tower safety slot covers
- 1 - power pack c/w hydraulic fitting assembly
- 16 - 5/8" x 5" concrete anchor bolts
- 1 - set of shim stock (16pcs. 3 x 3 x 1/16", 16pcs. 3 x 3 x 1/8")
- 1 - safety release handle c/w knob
- 1 - safety cable
- 1 - package of hardware, complete with its own packing list
- 9 - litres of 150 32 hydraulic oil

### 3. TOOLS REQUIRED

- rotary hammer drill
- 5/8" concrete drill bit
- 2' level, 4' level
- set of wrenches
- ball pion hammer
- step ladder
- crow bar (for shim installation)
- side cutters
- chalk line
- tape measure 16'
- Phillips screwdriver

### 4. INSTALLATION INSTRUCTIONS

When the Model 8020/8021 Wheel Free TWIN POST HOIST arrives on site, please read the installation instructions and gather the tools and materials required for installation.

#### Unpacking Procedure

1. The hoist will arrive in two (2) packages, a 29 x 24 x 110 inch package and a 13 x 19 x 42 inch accessory box.
2. **IMPORTANT - PLACE THE PACKAGE CONTAINING THE MAIN STRUCTURAL MEMBERS ON WOODEN BLOCKS - THESE BLOCKS MUST BE PLACED UNDER THE TOWERS TO ENABLE YOU TO REMOVE THE ANGLE IRON PACKING FRAMES.**
3. Remove outer steel banding and packing material.
4. Remove cross member, both carriage covers and 2pc. cross over hydraulic line. (1pc. is 100" long, the other piece is 18" long).
5. Lay towers on floor with the carriage side up. Remove the steel bands and remove all wooden shipping blocks.

Unpacking procedure continued

6. Prepare the bay by selecting the location of the hoist relative to the walls. Draw a chalk line on the floor to represent the centre line of the bay and a second chalk line crossing at 90 degrees for locating the hoist towers. See Figure 1.

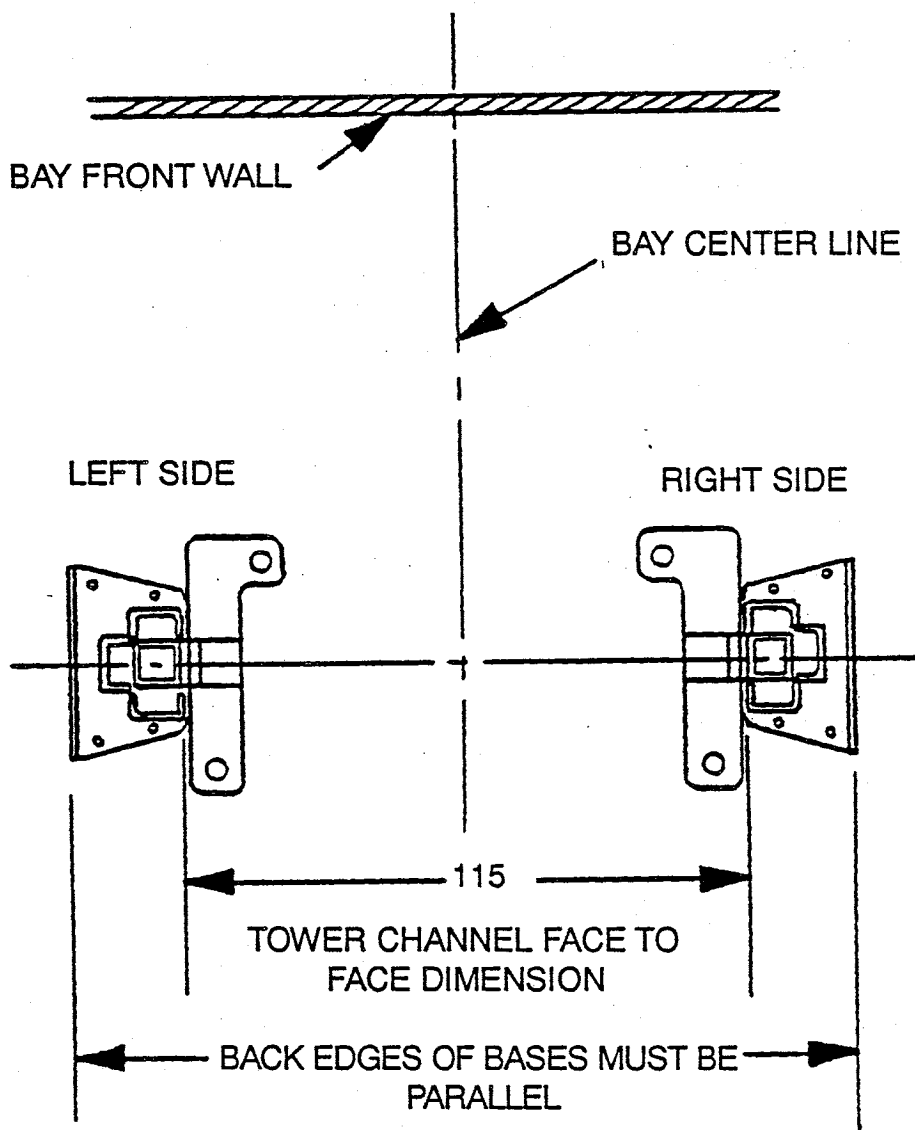

FIG. 1

THE HYDRAULIC SYSTEM HAS BEEN PRECHARGED WITH DEXON II  
THERE ARE CAPS ON THE HYDRAULIC LINES  
DO NOT REMOVE ANY CAPS UNTIL INSTRUCTED TO DO SO

### Tower Installation and Levelling

**NOTE:** Two men are required to erect the towers

1. Erect the left side tower (tower with the motor bracket) and the right side tower to the relative positions *as shown in Figure 1*. Check the 115" dimension.
2. Assemble the cross-over hydraulic line, and install it in the cross member, with the 90 degree bend at left side. *See Figure 2*.
3. Place cross member on support brackets at top of carriage, connect cross-over hydraulic line. **Note:** Before connecting this line, remove the caps from the fitting (on left side) and "T" (on right side) *See Figure 2*.
4. Install one (1) 1/2" x 5 1/2" bolt in the middle bolt hole at both ends of the cross member.
5. Install safety cable in the cross member. Looped end should be fished from left side to right side. **Be sure the SAFETY CABLE passes ABOVE the BOLTS.**  
*See Figure 2.*

**NOTE: SAFETY CABLE TO BE LOCATED ABOVE BOLTS**

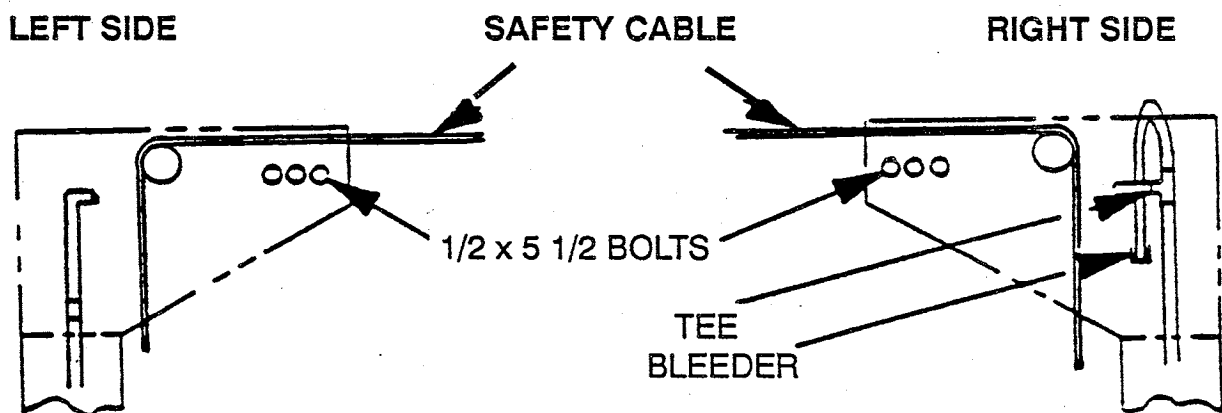
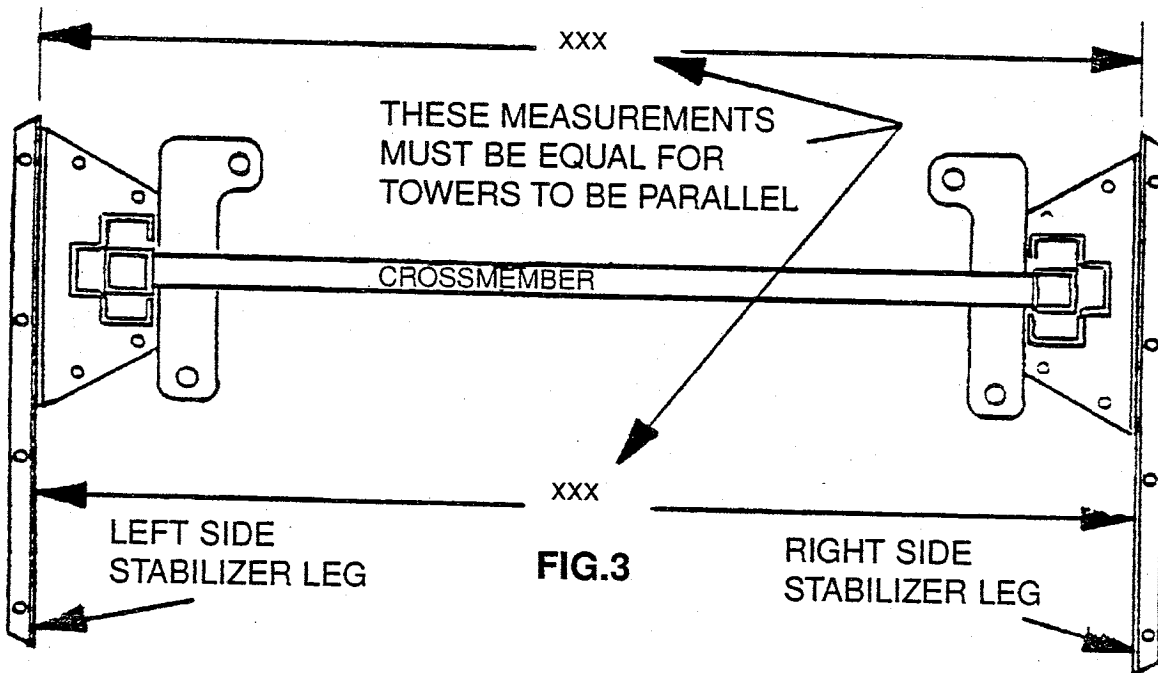

FIG. 2

**BOTH TOWERS MUST BE ON THE SAME PLANE OR ELEVATION**  
**BOTH TOWERS MUST BE PERPENDICULAR (ie. straight up and down)**

6. Bolt tower stabilizer legs (3 x 3 channels - 40" long) to tower base. Be sure long extension legs point to REAR of hoist. See Figure 3.
7. Check distance between stabilizer legs to ensure that towers are parallel. See Figure 3.



8. Using a level on the cross member, determine the High Side Tower. See Figure 4.
9. Install ANCHOR BOLTS in the "High Side Tower" but **DO NOT TIGHTEN**.
10. SHIM the High Side Tower to the vertical position and tighten all anchor bolts.
11. Install anchor bolts on remaining tower. **DO NOT TIGHTEN ANCHOR BOLTS.**

**DETERMINE THE "HIGH SIDE TOWER"**

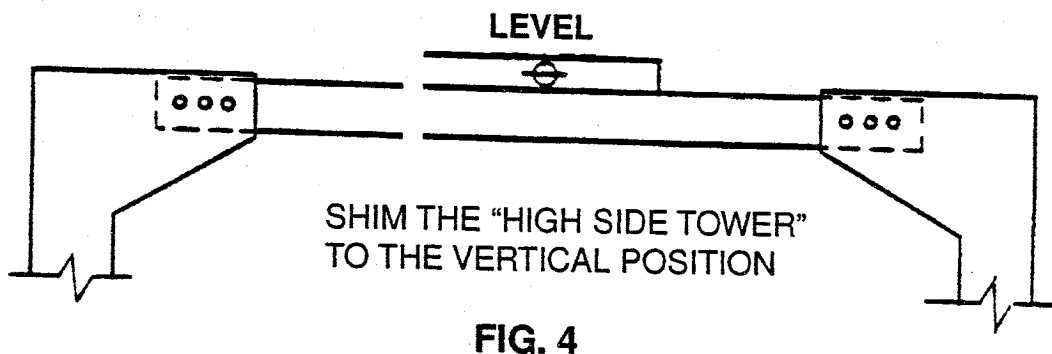

**BEFORE SHIMMING AND ANCHORING THE REMAINING TOWER,  
THE HYDRAULIC SYSTEM HAS TO BE INSTALLED AND BLED  
AND  
THE TELESCOPIC ARMS HAVE TO BE INSTALLED**

**INSTALLATION OF TELESCOPIC ARMS**

1. Remove 5/16" x 3/4" hex head bolts that are locking the arm pins to the arm. Install telescopic arms on carriage, short arms on the front and long arms to the rear. *See Figure 5.*
2. Grease and insert arm pins, re-lock with 5/16" x 3/4" hex bolts.
3. Install lift pads in all arms.

**LOCKING ARM MODEL EELR302A**

The arm locks are designed to automatically disengage when the lift is fully lowered. The arm lock adjustment bolt should be set and locked in position by the jam nut at time of installation. *See Figure 5A.*

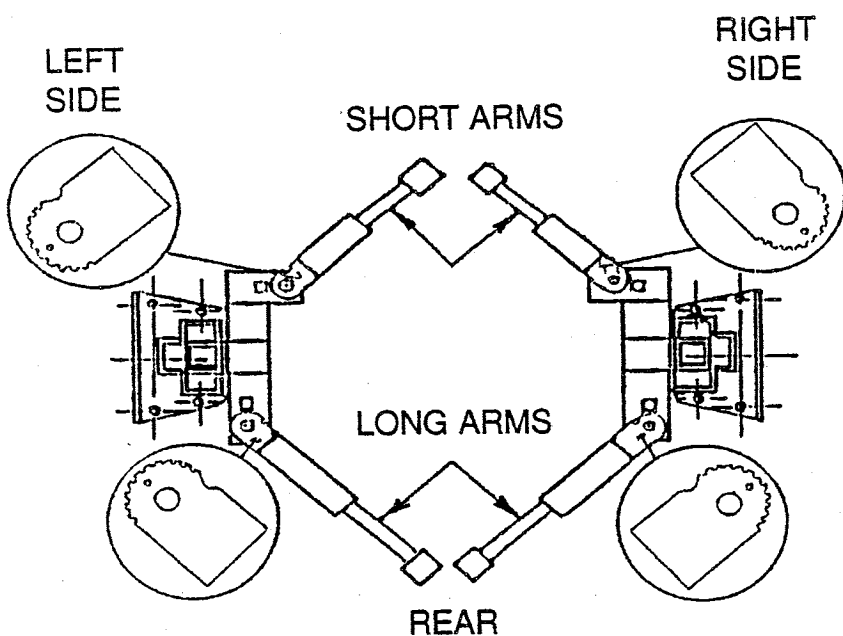

**FIG. 5**

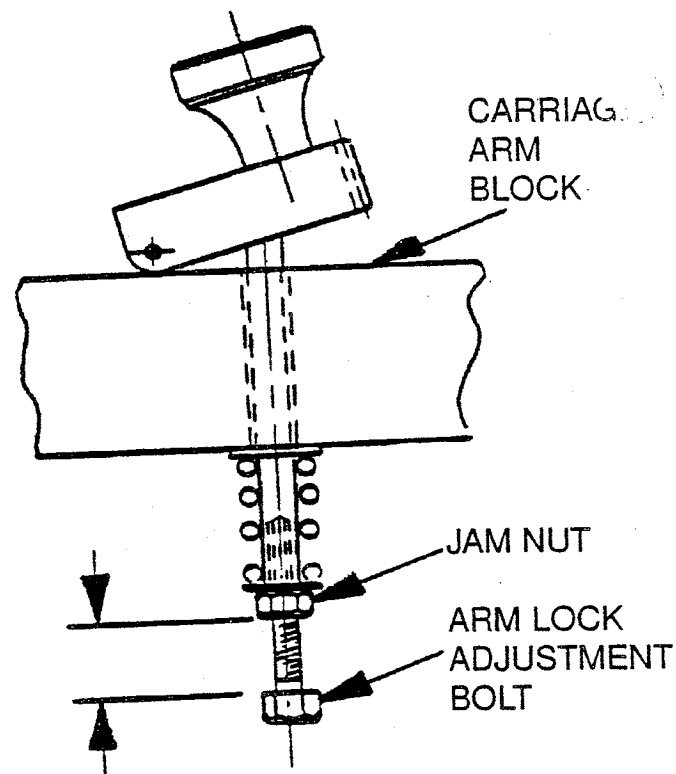

**FIG. 5A**



## HYDRAULIC SYSTEM INSTALLATION

### **REMOVE THE POWER PACK FROM THE ACCESSORY BOX**

Remove AND DISCARD THE PLASTIC PLUG, fill RESERVOIR with HYDRAULIC OIL 150 32, install BREATHER CAP in the reservoir fill spout.

2. A 90 deg. elbow is factory installed in the Power Pack Pump discharge port. Connect the pre-assembled "hydraulic fitting assembly" to this 90 degree elbow.

See Figure 6.

### HYDRAULIC FITTING ASSEMBLY

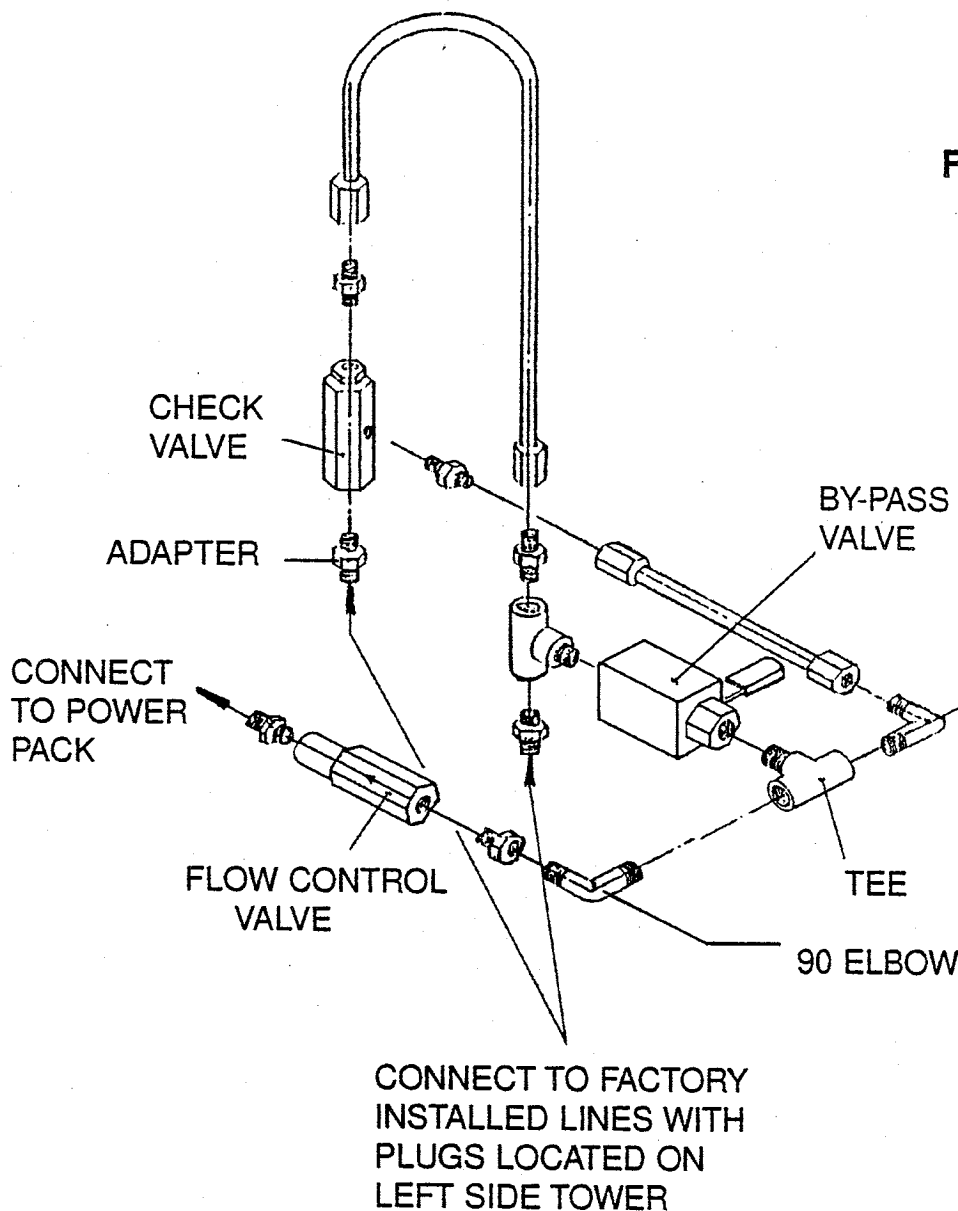

**NOTE: DO NOT REMOVE PLUGS OR CAPS UNTIL INSTRUCTED TO DO SO**

## HYDRAULIC SYSTEM INSTALLATION CONTINUED

**NOTE: Two men are required to mount the power pack.**

3. Bolt Power Pack to the mounting bracket on the Drive Side Tower using the 4- 15/16" x 1" bolts, nuts and washers. Bolt power pack on the outside of the mounting bracket.

4. An electrician must connect the 220 volt/single phase power pack to the Power Pack Motor. **A wiring diagram is provided.** (See Figure 8). The motor rotation is indicated on the power pack. (See Figure 7). After the motor is wired, jog the motor (push up on the control lever) and verify the motor rotation through the inspection hole. (See Figure 7).

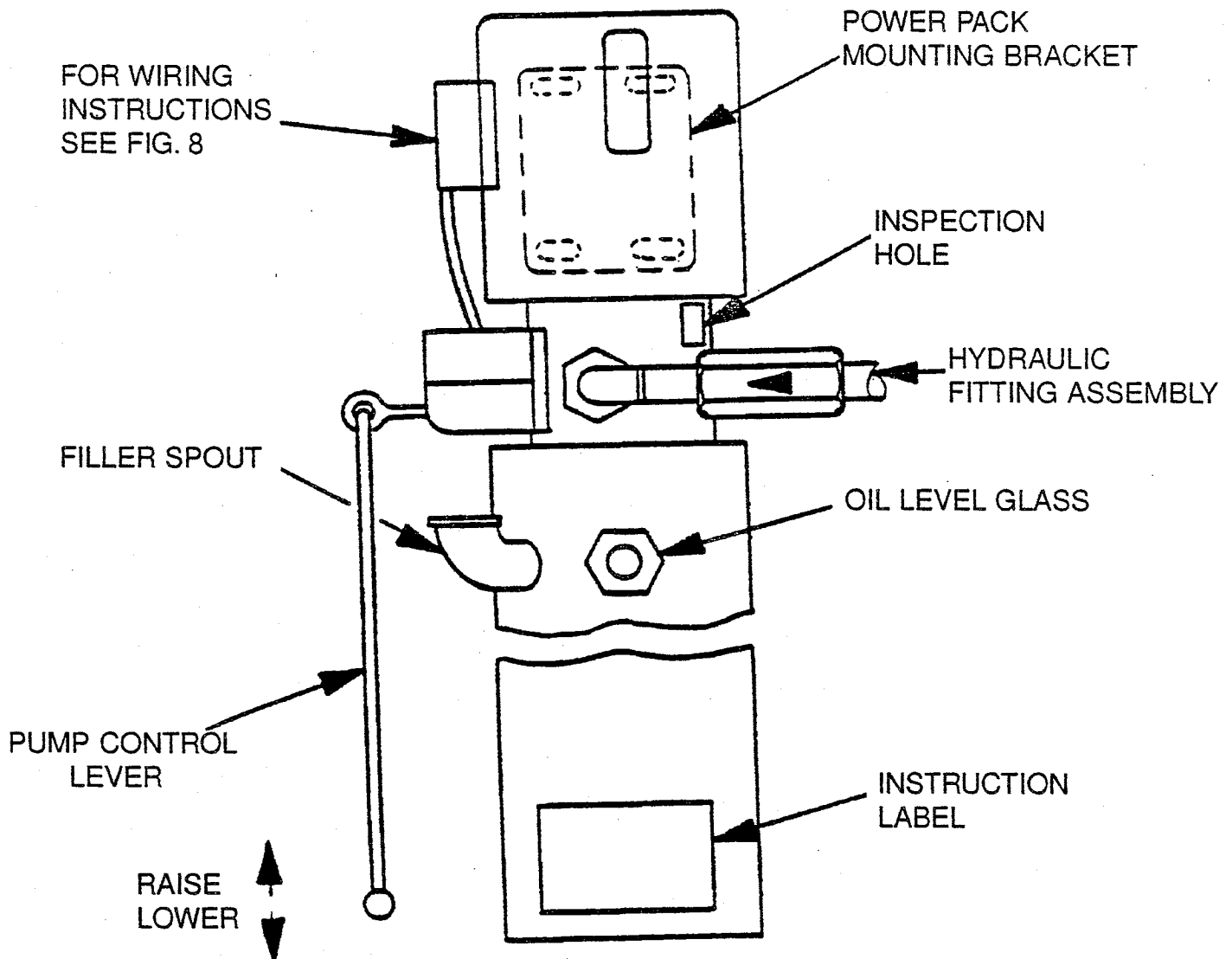

**FIG. 7**

# WIRING DIAGRAM 220V/1 PHASE

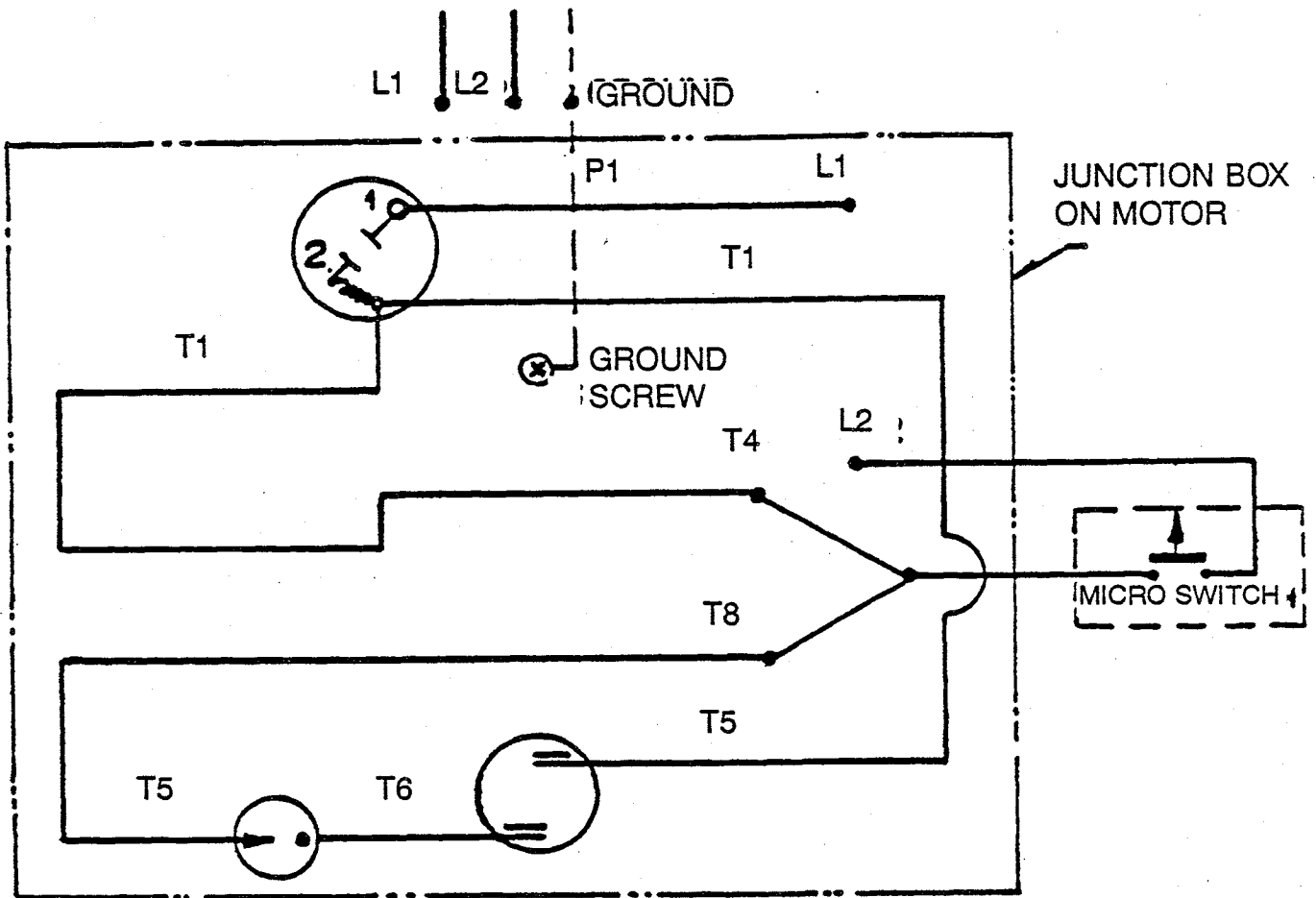

ROTATION FACING LEAD END	L1	L2	JOIN & INSULATE
C.W. ROTATION	P1	T4 T8	T1 T5

1. USE ONLY APPROVED CONNECTOR.
2. CONNECT L1 TO P1 IN JUNCTION BOX
3. CONNECT L2 TO BLACK WIRE IN JUNCTION BOX FROM MICRO SWITCH.

FIG. 8

## HYDRAULIC SYSTEM BLEEDING PROCEDURE

1. There are two hydraulic lines (1/4" and 3/8") on the left side tower. **BOTH lines have FACTORY INSTALLED PLUGS in them.**

**DO NOT REMOVE PLUG FROM THE 3/8" LINE (Fig. 6)**

**DO NOT REMOVE 3/8" CAP FROM CHECK VALVE (Fig. 6)**

2. Remove the PLUG from the 1/4" line. Connect this line to the 1/4" fitting on the Hydraulic Fitting Assembly. (See Fig. 6). **OPEN BY-PASS VALVE** by turning handle "in line" with the valve body.

3. Remove the 3/8" PLUG on the bleeder line coming down the face of the right side carriage. (See Fig. 9) **NOTE: Have a container ready to catch the hydraulic oils that will come out of the bleeder line in step 4.**

4. Jog the motor control lever up until clear hydraulic oil comes out of the bleeder. You should bleed at least one (1) litre of fluid. **RE-INSTALL THE STEEL BLEEDER PLUG AND TIGHTEN SECURELY.**

5. **WITH BY-PASS VALVE OPEN**, jog motor control lever up to **RAISE RIGHT SIDE CARRIAGE 6 INCHES.** **PULL DOWN ON CONTROL LEVER AND LOWER RIGHT SIDE CARRIAGE. REPEAT THIS PROCEDURE 15 TIMES!!!** **CLOSE BY-PASS VALVE.**

6. On left side tower, remove PLUG from 3/8" line. Remove CAP from CHECK VALVE. Connect the 3/8" line TO CHECK VALVE (See Figure 6). **BE SURE BY-PASS VALVE IS CLOSED.** Jog motor control lever up to **RAISE HOIST 6 INCHES.** Pull control lever down to **LOWER.** **REPEAT 6 TIMES!!!**

# HYDRAULIC SYSTEM SCHEMATIC

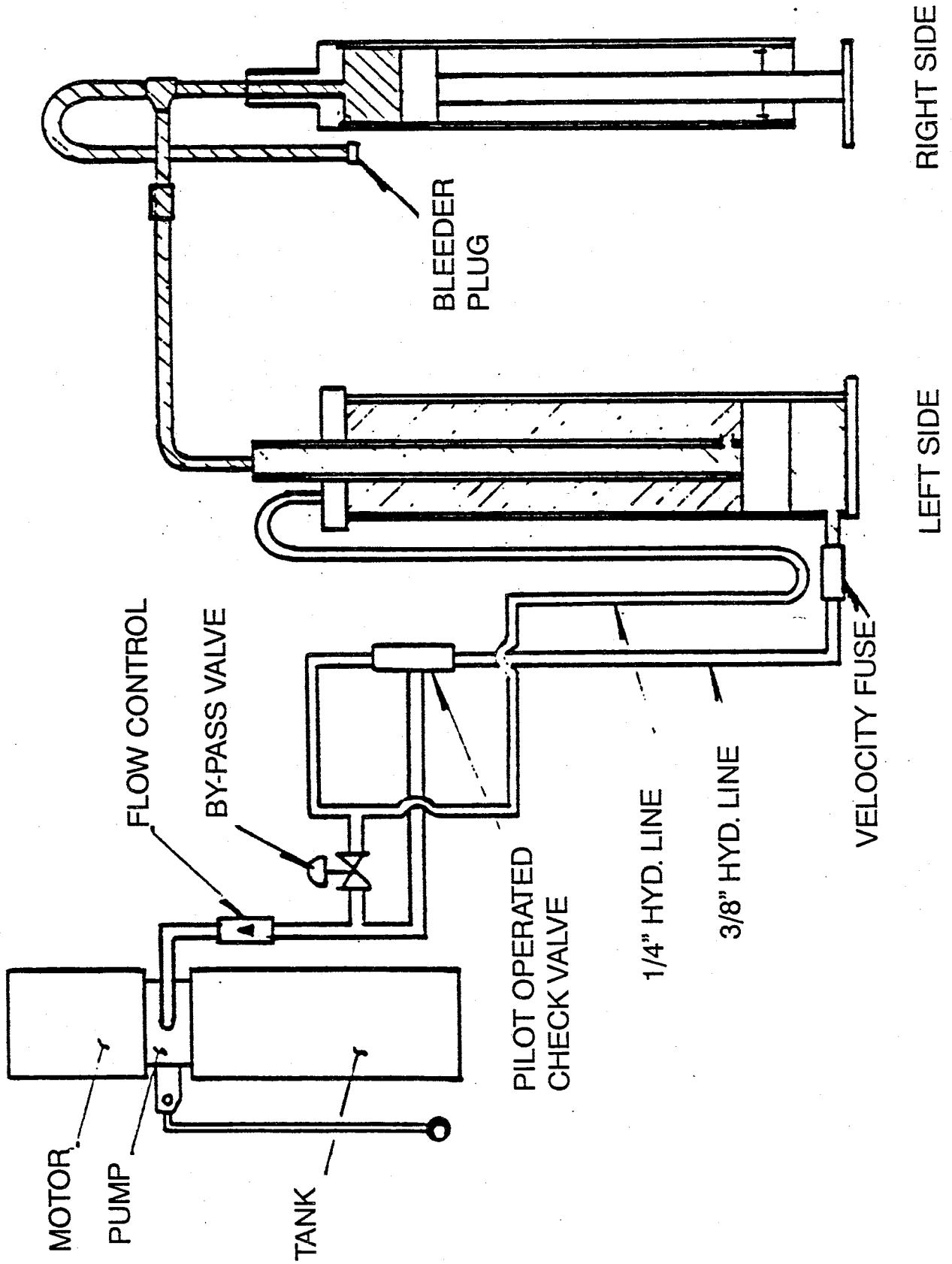

## SHIMMING OF REMAINING TOWER

1. **BEFORE SHIMMING THE REMAINING TOWER, BOTH SAFETY DOGS MUST BE ENGAGED IN THE BOTTOM SAFETY SLOT.**

2. **OPEN THE BY-PASS VALVE, and POWER UP UNTIL THE LEFT SIDE SAFETY DOG ENGAGES IN THE FIRST (bottom) SAFETY SLOT.**

With the by-pass valve open, the right side carriage will raise faster than the left side carriage. When the left side engages in the first safety slot, the right side will be above the first safety slot.

3. **PULL DOWN ON POWER PACK CONTROL LEVER - this will lower right side carriage into the first (bottom) safety slot. CLOSE BY-PASS VALVE.**

4. Place 4' level on cross member and shim to get both towers on the same plane or elevation.

5. Place 2' level on faces of the tower channels and shim until tower is straight up and down on all faces.

6. Install remaining bolts in cross member. **BE SURE SAFETY CABLE PASSES ABOVE THE BOLTS.** Tighten all cross member bolts.

7. **TIGHTEN ALL ANCHOR BOLTS**

8. **RECHECK THAT HOIST IS LEVEL (by placing a level on the cross member) and RECHECK THAT TOWERS ARE VERTICAL - add shims if necessary.**

### **CAUTION: correct use of WEDGE ANCHOR BOLTS**

The 5/8" x 5" wedge anchor bolts supplied allow for the thickness of the base plate PLUS A MAXIMUM OF 1 INCH OF SHIM STOCK.

**DO NOT USE ANCHORS SUPPLIED IF MORE THAN 1 INCH OF SHIM STOCK IS USED**

Lifts should only be installed on "level" concrete floors with a minimum thickness of five (5) inches. Concrete must have a minimum tensile strength of 4,000 psi, and should be aged 30 days prior to the installation of the lift.

## SAFETY CABLE ADJUSTMENT

1. The safety cable (PREVIOUSLY INSTALLED IN CROSS MEMBER) now needs to be connected and adjusted to ensure that both safety mechanisms engage and disengage in both towers at the same time.
2. Attach safety release handle to the left side safety mechanism with the cotter pin as shown in Figure 10.
3. Run the safety cable over the pulleys at the top of each carriage. With your assistant holding one end, move the safety cable up and down to be sure it is not snagging in the cross member. **Recheck that the safety cable is running above the cross member bolts.**
4. Connect the "loop end" of the safety cable to the right side safety mechanism using the 1/4" x 3/8" shoulder bolt. **Use lock tight to secure this shoulder bolt.** (See Fig. 10).
5. Place the "male threaded end" of the safety cable through the "L" bracket on the left side safety mechanism. Install a 1/4" nut above and below the bracket. **Do not tighten the nuts.** (See Fig. 10).

FIG. 10

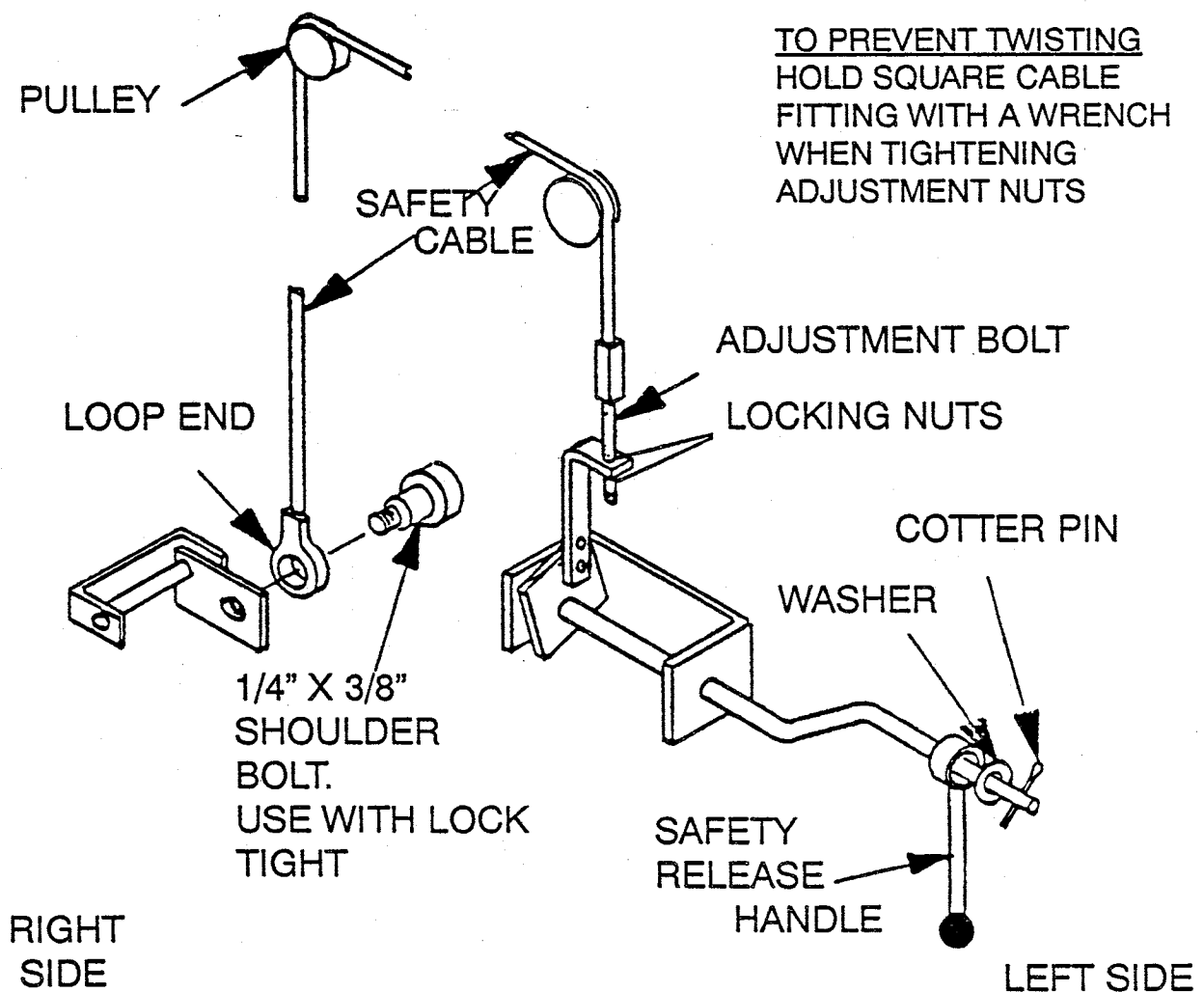

## SAFETY ADJUSTMENT

6. Raise the hoist until the safety dog is in the middle of the first safety slot. (Safety slot can be seen through the square slots on the back of the tower). In this position, the safety can move freely when the safety release handle on the left side is pulled down.

7. Adjust the safety cable on the left side mechanism so that both safety dogs travel from full engagement position to full release position when the safety release handle is pulled down. Tighten 1/4" lock nut on safety cable when adjustment is completed.

8. Lower carriage (by pulling down on the power pack control lever) until both safety dogs engage in the first safety slot. If safety dogs do not engage at the same time, a **HYDRAULIC ADJUSTMENT IS MADE to the RIGHT SIDE-** proceed as follows:

### WHEN RIGHT SIDE IS HIGH

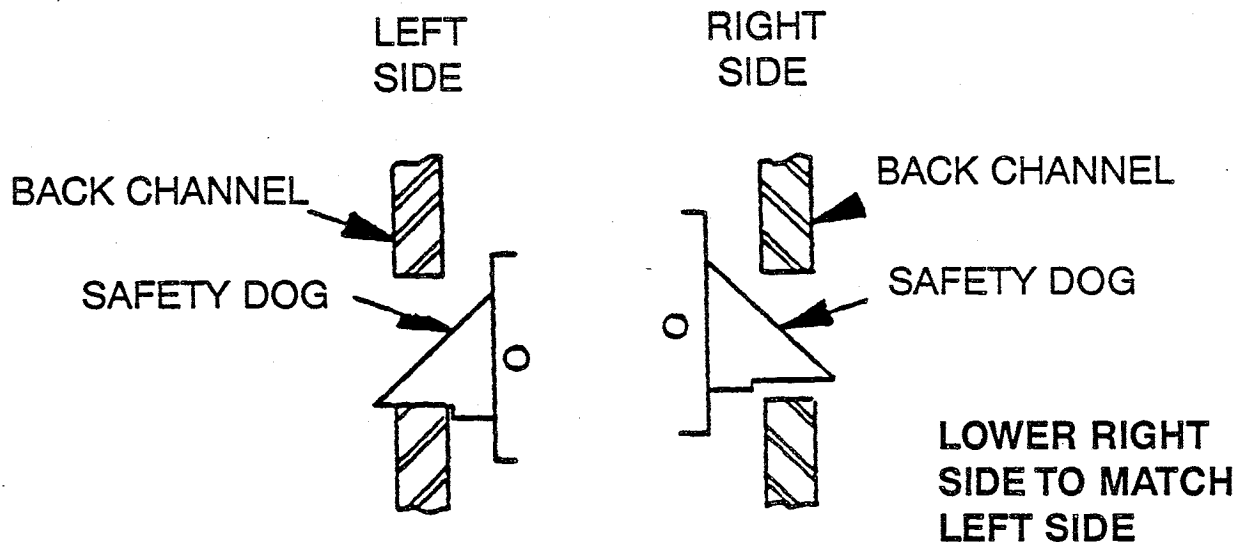

FIG. 11

Open by-pass valve and jog down control lever until right side is on safety stop level with left side. CLOSE BY-PASS VALVE.



**SAFETY ADJUSTMENT CONTINUED**

**WHEN RIGHT SIDE IS LOW**

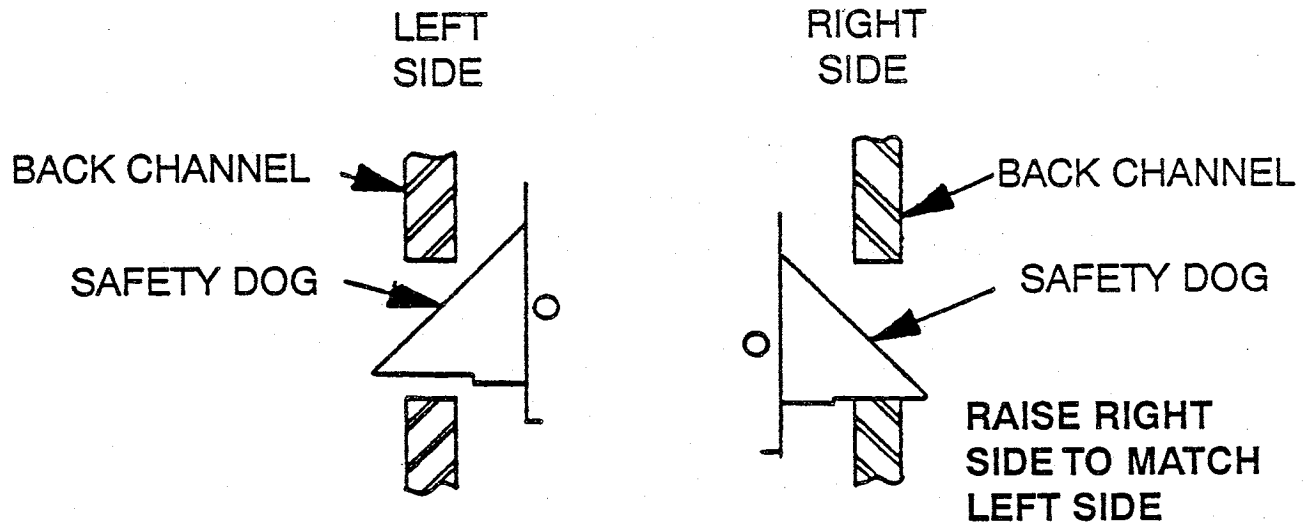

**Open by-pass valve, raise hoist, until right side safety dog is 1" higher than left side safety dog. CLOSE THE BY-PASS VALVE.**

**LOWER HOIST UNTIL the LEFT SIDE SAFETY DOG ENGAGES in the first (bottom) safety slot. OPEN BY-PASS VALVE, and jog DOWN on the control lever until the RIGHT SIDE SAFETY DOG engages in the first (bottom) safety slot. CLOSE THE BY-PASS VALVE.**

**REMOVE HANDLE FROM BY-PASS VALVE AND  
STORE IN SAFE LOCATION**

## INSTALLATION OF SAFETY COVERS

1. Install VISU [clear] safety covers over the safety slots on the back of both the left side and right side towers. These four (4) covers are in the accessory box. Use the 1/4" x 5/8" bolts to secure these covers.
2. Install the carriage safety covers on the front of each carriage (to cover safety mechanism and cable). The left side cover has two (2) slots cut out at the bottom, right side cover has one (1) slot cut out at the bottom.

**NOTE: Place covers over safety cable and be sure they BUTT securely against the gusset on the bottom of the carriage. Secure with the #10 x 3/4" self-tapping screws - INSTALL 2 SCREWS AT THE TOP OF EACH COVER.**

MODEL 8021 HOIST - Install Engine Hoist Bracket on cross bar.

## HYDRAULIC LEVELLING

**Should your lift come out of synchronization, ie. one carriage is higher than the other, it is necessary to level the lift hydraulically.**

This can easily be done by following the procedure entitled "SAFETY ADJUSTMENT", steps 6,7 and 8, referring to Figures 11 and 12.

If you require assistance, contact your service representative.

## 5. SAFETY AND OPERATING INSTRUCTIONS

1. Inspect your hoist daily. Do not operate it if it malfunctions or has damaged parts.

Never attempt to overload the hoist. The manufacturer's rated capacity is shown on the instruction label on the power pack.

3. Operating controls are designed to function automatically. Do not override them.

4. Only trained and authorized personnel should operate the hoist. Do not allow customers or bystanders to operate the hoist or be in the hoist area.

5. Position the lift support pads to contact the vehicle manufacturer's recommended lifting points. Raise the hoist until the pads contact the vehicle. Check pads for secure contact with the vehicle, then raise the hoist to the desired working height.

**6. Caution: Never work under the hoist unless the mechanical safety locks are engaged.**

7. Note that the removal or installation of some vehicle parts may cause a critical shift in the center of gravity and may cause the vehicle to become unstable. Refer to the vehicle manufacturer's service manual for recommended procedures.

8. Always keep the hoist area free of obstruction and debris. Grease and oil spills should always be cleaned up immediately.

Never raise vehicle with passengers inside.

10. Before driving vehicle between the posts, position the arms to the drive-through position to ensure unobstructed clearance. Do not hit or run over arms as this could damage the hoist and/or the vehicle.

11. Before removing the vehicle from the hoist area, position the arms to the drive-through position to prevent damage to the hoist and/or vehicle.

## 6. MAINTENANCE INSTRUCTIONS

1. Inspect the hoist daily, to assure the mechanical safety is operating correctly.
2. Check the sight glass on the power pack tank (when hoist is in the down position) to verify tank is full of hydraulic oil.
3. Check the telescopic arms for movement. Clean any grease or oil from the lifting pads.
4. Raise and lower the lift at the beginning of each shift, without a vehicle on it, to verify lift is operating properly.
5. Lubricate safety dog mechanism with WD-40 monthly. Remove cover and spray WD-40 through safety slots in rear channel. (*See Fig. 13*).

# **WHEELTRONIC "WHEELFREE" TWIN POST LIFT MODEL 8020 / 8021**

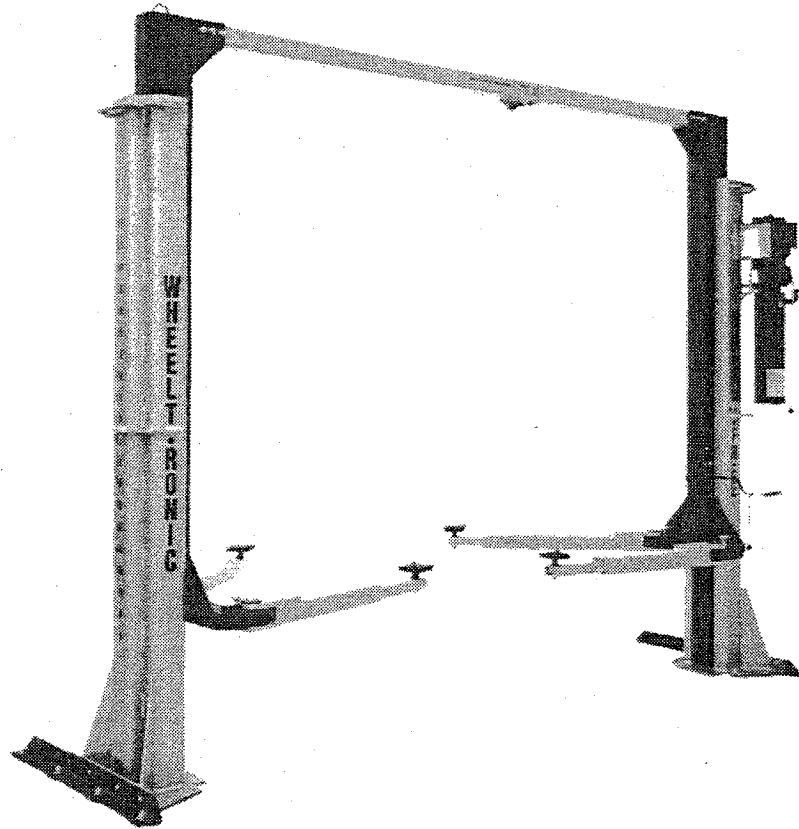

## **PARTS MANUAL**

---

**SAVE THESE INSTRUCTIONS  
READ ALL INSTRUCTIONS**

**WHEELTRONIC LTD.** 

1125 AEROWOOD DRIVE, MISSISSAUGA, ONTARIO L4W 1Y6  
TEL: (905) 238-0909 • FAX: (905) 238-9061

# TWIN POST HOIST

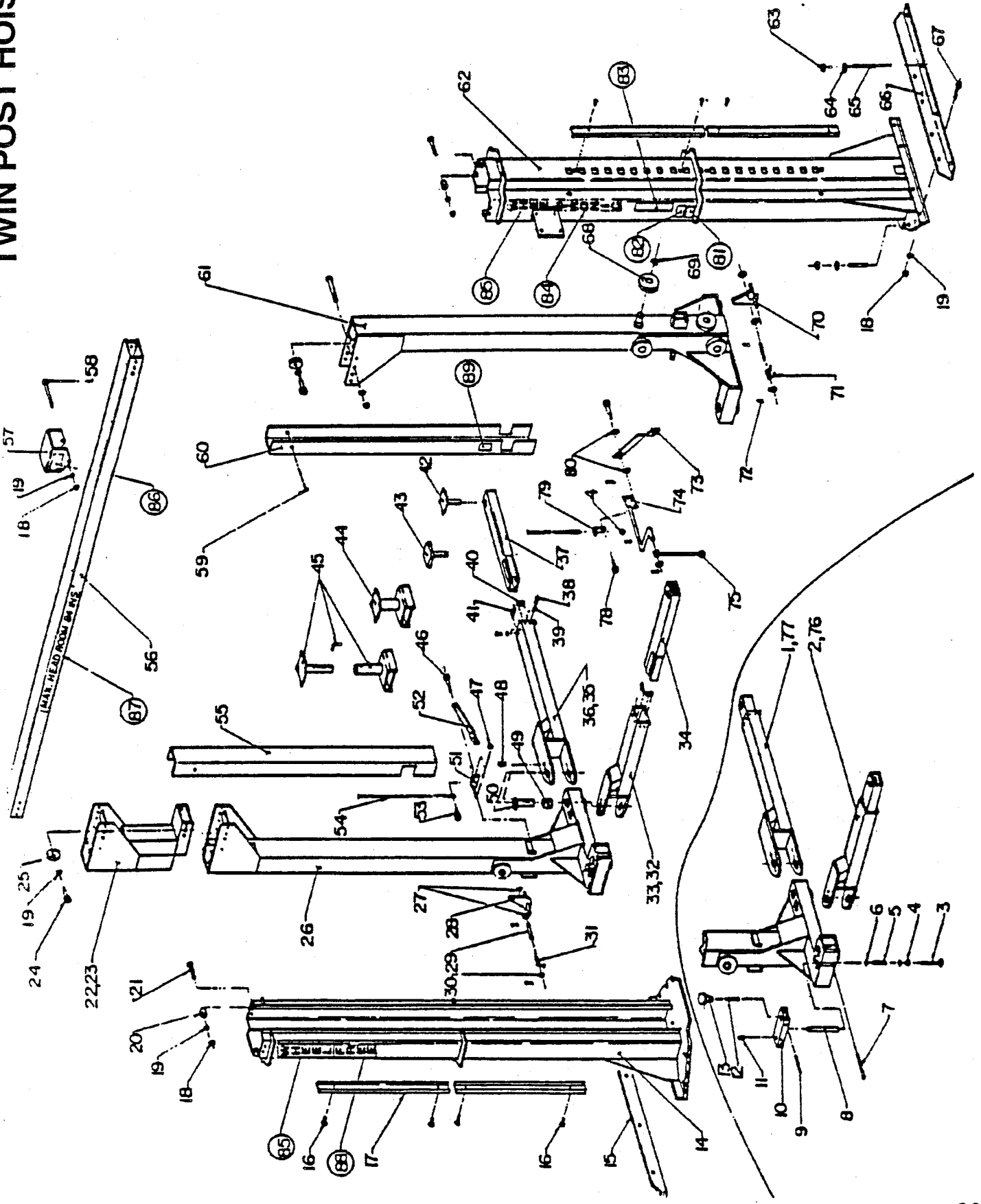

# TWIN POST ASSEMBLY

ITEM NO.	PART NO.	QTY.	DESCRIPTION
1.	4-0166	1	LONG LOCKING ARM ASSEMBLY (R.S.)
2.	4-0165	1	MEDIUM LOCKING ARM ASSEMBLY (R.S.)
3.	6-0027	4	HEX BOLT, 1/4" - 20 UNC X 1 1/4" LG.
4.	6-0032	5	HEX NUT 1/4" - 20 UNC
5.	1-0332	4	PLUNGER SPRING
6.	6-0060	4	FLAT WASHER 1/4" I.D.
7.	1-0333	4	PIVOT PIN
8.	1-0334	4	PLUNGER PIN
9.	6-0437	4	ROLL PIN, 1/8" X 1" LG.
10.	2-0249	4	RACK
11.	6-0438	4	SET SCREW, 1/4" - 20 UNC X 1/2" LG.
12.	1-0387	4	THREADED ROD, 3/8" - 16 UNC X 1 1/2" LG.
13.	1-0208	4	KNOB
14.	4-0169	1	TOWER WELDMENT, RIGHT SIDE
15.	3-0097	1	TOWER SUPPORT ANGLE, RIGHT SIDE
16.	6-0335	8	SCREW, 1/4" - 20 UNC X 5/8" LG.
17.	2-0235	4	TOWER SAFETY COVER
18.	6-0035	23	HEX NUT, 1/2" - 13 UNC
19.	6-0059	23	LOCK WASHER, 1/2" I.D.
20.	1-0284	8	CARRIAGE STOP
21.	6-0315	8	HEX BOLT, 1/2" - 13 UNC X 2 1/4" LG.
22.	3-0310	2	EXTENSION WELDING 24" LG. (OPTIONS)
23.	3-0226	2	EXTENSION WELDING 18" LG. (OPTIONS)
24.	6-0069	2	SHOULDER SCREW, 3/8" X 5/8" LG.
25.	1-0415	2	SAFETY CABLE PULLEY
26.	4-0175	1	CARRIAGE WELDMENT, RIGHT SIDE
27.	6-0387	4	THRUST WASHER 1/2" I.D. X .03"
	6-0419	2	THRUST WASHER 1/2" I.D. X .06"
28.	2-0523	1	SAFETY DOG WELDMENT, RIGHT SIDE
29.	1-0260	2	SAFETY DOG PIVOT PIN
30.	6-0063	3	FLAT WASHER, 1/2" I.D.
31.	1-0249	1	SAFETY SPRING, RIGHT SIDE
32.	3-0315	1	RIGHT SIDE MEDIUM OUTER ARM WELD

ITEM NO.	PART NO.	QTY.	DESCRIPTION
33.	3-0318	1	LEFT SIDE MEDIUM OUTER ARM WELD
34.	2-0192	2	INNER ARM MEDIUM WELDING
35.	3-0314	1	RIGHT SIDE LONG OUTER ARM WELD
36.	3-0317	1	LEFT SIDE LONG OUTER ARM WELD
37.	2-0191	2	INNER ARM LONG WELDING
38.	6-0056	16	LOCK WASHER, 1/4" I.D.
39.	6-0339	16	HEX BOLT, 1/4" - 28 UNF X 5/8"LG.
40.	1-0263	4	ARM STOP, SIDE
41.	1-0262	4	ARM STOP, TOP
42.	2-0304	4	LOW LIFTING PAD, (OPTIONS)
43.	3-0170	4	LOW LIFTING PAD, NEOPRENE
44.	3-0194	4	STANDARD TRUCK PAD
45.	3-0218	4	ADJUSTABLE TRUCK PAD ASSEMBLY (OPTIONS)
46.	6-0591	2	SHOULDER SCREW, 5/16" X 1"LG.
47.	6-0362	2	RETAINING RING, 'E' TYPE
48.	6-0423	4	HEX BOLT, 5/16" - 18 UNC X 3/4"LG.
49.	6-0551	8	SELF-LUB. BRONZE BEARING
50.	2-0439	4	ARM PIN
51.	1-0326	1	SAFETY LINKAGE PIVOT
52.	3-0108	1	SAFETY LINK, LONG RIGHT SIDE
53.	6-0244	1	SHOULDER SCREW 1/4" X 3/8"LG.
54.	1-0239	1	SAFETY CABLE
	1-0736	1	SAFETY CABLE (EXTENSION 24" LG.)
	1-0737	1	SAFETY CABLE (EXTENSION 18" LG.)
55.	3-0126	1	CARRIAGE COVER, RIGHT SIDE
56.	3-0093	1	CROSS MEMBER
57.	3-0109	1	MOTOR HOIST BRACKET
58.	6-0290	7	HEX BOLT, 1/2" - 13 UNC X 5 1/2"LG.
59.	6-0297	4	SELF-TAPPING SCREW, NO. 10 X 3/4"LG.
60.	3-0125	1	CARRIAGE COVER, LEFT SIDE
61.	4-0174	1	CARRIAGE WELDMENT, LEFT SIDE
62.	4-0170	1	TOWER WELDMENT, LEFT SIDE



ITEM NO.	PART NO.	QTY.	DESCRIPTION
63.	6-0036	16	HEX NUT, 5/8" - 11 UNC.
64.	6-0064	16	FLAT WASHER, 5/8" I.D.
65.	6-0316	16	WEDGE ANCHOR, 5/8" - 11 UNC X 5" LG.
66.	3-0096	1	TOWER SUPPORT ANGLE LEFT SIDE
67.	6-0047	8	HEX BOLT, 1/2" - 13 UNC X 1 3/4" LG.
68.	2-0496	12	CARRIAGE WHEEL
69.	6-0233	12	RETAINING RING, FOR WHEEL 1 3/8" I.D.
70.	2-0522	1	SAFETY DOG WELDMENT, LEFT SIDE
71.	1-0369	1	SAFETY SPRING, LEFT SIDE
72.	6-0267	7	COTTER PIN 1/8" DIA. X 1" LG.
73.	3-0107	1	SAFETY LINK, LONG, LEFT SIDE
74.	3-0137	1	SAFETY RELEASE LEVER
75.	2-0293	1	SAFETY RELEASE HANDLE
76.	4-0177	1	LONG LOCKING ARM ASSEMBLY (L.S.)
77.	4-0176	1	MEDIUM LOCKING ARM ASSEMBLY (L.S.)
78.	6-0240	1	SHOULDER SCREW, 1/4" X 1/4" LG.
79.	1-0259	1	CABLE CONNECTING BRACKET
80.	6-0295	4	PLAIN WASHER, 5/16" I.D.
81.	6-0397	1	SERIAL NO. PLATE
82.	6-0398	1	"ALI" PLATE
83.	6-0592	1	"CAUTION" DECAL
84.	6-0480	1	"TRONIC" DECAL
85.	6-0478	2	"WHEEL" DECAL
86.	6-0352	1	"MAX CAP. 1000 LB." DECAL
87.	6-0353	1	"MAX. HEAD ROOM 84" INC." DECAL
88.	6-0479	1	"FREE" DECAL
89.	6-0349	1	"SAFETY RELEASE" DECAL



TWIN POST HYDRAULICS

ITEM NO.	PART NO.	QTY.	DESCRIPTION
1.	6-0303	1	POWER PACK INC. 90 ELBOW
2.	6-0268	1	ELBOW 90, 3/8" M, NPT 3/8" M, NPT
3.	6-0379	4L	HYDRAULIC OIL, ISO-32 (12 LITERS)
4.	4-0171	1	CYLINDER ASSEMBLY (RIGHT SIDE)
5.	6-0425	2	SHOULDER SCREW
6.	3-0328	1	CYLINDER BARREL WELDMENT
7.	0-0162	1	GLAND KIT, RIGHT SIDE
8.	3-0329	1	PISTON ROD WELDING
9.	6-0580	3	ALLEN HD 1/4" -20 UNC 3/8" LG. SET SCREW
10.	2-0511	1	PISTON
11.	0-0159	1	PISTON SEAL KIT (RIGHT SIDE)
12.	1-0725	1	KEEPER WASHER
13.	6-0285	2	ADAPTER, 3/4" M, NPT 3/8" F, NPT
14.	6-0371	1	PLUG, 3/8" JIC
15.	6-0340	2	CIRCLIP
16.	6-0345	1	ADAPTER, 3/8" M, JIC 3/8" M, NPT 2 1/4" LG.
17.	6-0284	1	TEE 3/8" F, JIC, SWIVEL 3/8" M, JIC 3/8" M, JIC
18.	1-0093	1	TUBE ASSEMBLY, 3/8" I.D.
19.	3-0112	1	TUBE ASSEMBLY, 3/8" I.D.
20.	6-0286	1	UNION, 3/8" M, JIC 3/8" M, JIC
21.	3-0113	1	TUBE ASSEMBLY, 3/8" I.D.
22.	3-0139	1	HYDRAULIC FITTING ASSEMBLY
23.	6-0011	1	ADAPTER, 3/8" M, NPT, 3/8" M, JIC
24.	3-0110	1	TUBE ASSEMBLY, 1/4" I.D.
25.	3-0114	1	TUBE ASSEMBLY, <del>1/4"</del> I.D. 3/8"
26.	6-0278	1	ELBOW 90, 1/4" M, JIC 1/4" M, JIC
27.	6-0422	1	VELOCITY FUSE, 4 GPM
28.	3-0229	1	TUBE ASSEMBLY, 1/4" I.D.
29.	6-0280	1	ADAPTER, 1/8" M, NPT, 1/4" M, JIC
30.	3-0334	1	CYLINDER BARREL WELDMENT
31.	0-0160	1	PISTON SEAL KIT, LEFT SIDE
32.	6-0586	1	NILON INSERT LOCKNUT 7/8" 9 UNC.
33.	2-0521	1	PISTON SPIGOT
34.	3-0335	1	PISTON ROD WELDMENT

ITEM NO.	PART NO.	QTY.	DESCRIPTION
35.	0-0161	1	GLAND SEAL KIT, LEFT SIDE
36.	1-0280	1	TUBE ASSEMBLY, 1/4" I.D.
37.	1-0281	1	TUBE ASSEMBLY, 3/8" I.D.
38.	6-0272	1	BALL VALVE
39.	6-0274	1	ELBOW 90, 3/8"M, JIC 1/4"M, NPT
40.	6-0271	1	TEE, 1/4"M, NPT, 3/8"F, NPT
41.	6-0270	1	ADAPTER, 1/4"M, NPT, 3/8"M, NPT
42.	6-0536	2	TUBE CLAMP
43.	6-0136	2	1/4" - 20 UNC X 1/2"LG. RD. HD. SCREW
44.	6-0090	1	FLOW CONTROL
45.	6-0269	1	ELBOW 135, 3/8" SWIVEL F, NPT 3/8"M, NPT
46.	6-0279	1	ELBOW 135, 1/4"M, NPT 1/4"M, NPT
47.	6-0276	2	ADAPTER, 1/4"M, NPT 3/8"M, JIC
48.	6-0281	2	ADAPTER, 1/4"M, JIC 1/4"M, NPT
49.	6-0277	1	PILOT-OPERATED CHECK VALVE
50.	4-0173	1	DOUBLE-ACTION HYDRAULIC CYLINDER ASS'Y
51.	1-0734	1	FELT STRIP
52.	6-0593	1	"LIFT OPERATION" DECAL
53.	6-0594	1	"NOTICE" DECAL
54.	6-0595	1	"WARNING" DECAL

# POWER PACK

