

HOFMANN

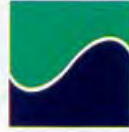

INSTALLATION and OPERATION MANUAL



14K SCISSOR LIFT **BLA14178, BLA14178FM, BLA14178LL**

**READ THIS INSTRUCTION MANUAL THOROUGHLY
BEFORE INSTALLING, OPERATING, SERVICING OR
MAINTAINING THE LIFT. SAVE THIS MANUAL.**

HOFMANN
USA

309 Exchange Avenue • Conway, AR 72032
(800) 251-4500 • (501) 505-2662
Fax (501) 450-2085 • www.hofmann-usa.com

HOFMANN
Canada

6500 Millcreek Drive • Mississauga, ONT L5N 2W6
(800) 267-2185
Fax (905) 821-2073 • www.hofmann.ca

JUN 2016 REV. - 6-3014

TABLE OF CONTENTS

1.0 OWNER / EMPLOYER OBLIGATIONS	4
2.0 IMPORTANT SAFETY INSTRUCTIONS	4
3.0 SAFETY WARNING DECALS	7
4.0 SPECIFICATIONS	8
5.0 CONTENTS	9
6.0 TOOLS REQUIRED FOR INSTALLATION OF LIFT	9
7.0 INSTALLATION OVERVIEW	10
8.0 INSTRUCTIONS	11
8.1 Flushmount Bay Layout.....	12
8.2 Surfacemount Bay Layout	13
8.3 Baseframe Location	14
8.4 Anchor Location	15
8.5 Unpacking the Lift	16
8.6 Hydraulic Connections	17
8.7 Air Safety and Auxiliary Air connections	19
8.8 Pneumatic Sensor Connections.....	22
8.9 Electrical Connections	24
8.10 Initial Operation	26
8.11 Equalizing Function Check.....	27
8.12 Maximum Height Adjustment	28
8.13 Level and Support	29
8.14 Anchoring Procedure.....	30
8.15 Grouting Procedure (Optional).....	31
9.0 ACCESSORY INSTALLATION	32
9.1 Installation of Line Covers.....	35
10.0 LOCKING FRONT TURNPLATES & REAR SLIP PLATES (OPTIONAL) 36	
10.1 Installation of Front Turnplates	36
10.2 Console Connections for Locking & Lights	38
11.0 FINAL PROCEDURES	40
11.1 Check of Assembled Lift.....	40
11.2 Operation Test with Vehicle.....	40
12.0 LIFT OPERATION	41
12.1 Raising the Lift.....	41
12.2 Lowering the Lift.....	41
13.0 RECOMMENDED MAINTENANCE	42
13.1 Checking Oil Level for Air Lubricator	42
13.2 Maintenance of Turnplate & Slip Plate Locking System (Opt.).....	43
14.0 LOCK OUT AND TAG OUT INSTRUCTIONS	45
14.1 Isolation and Verification Procedure:	46

14.2 Emergency Operation	47
15.0 TROUBLE SHOOTING	49
16.0 RECORD OF MAINTENANCE / TRAINING	50
17.0 LIFT ASSEMBLY	51
17.1 Lift Assembly Parts List.....	52
18.0 REAR SLIP PLATE TRANSFER BALL ARRANGEMENT.....	54
19.0 HYDRAULIC & AIR ASSEMBLY	55
19.1 Line Routing Parts List	57
20.0 HEIGHT LIMIT ASSEMBLY	58
20.1 HEIGHT LIMIT / LEVELING PARTS LIST	58
20.2 EQUALIZE SENSORS PARTS LIST	59
20.3 HEIGHT LIMIT / LEVELING PARTS LIST	59
20.4 OPTIONAL: LIGHT KIT SENSOR PARTS LIST	60
21.0 ACCESSORY ASSEMBLY	61
21.1 Front Turnplate	61
21.2 Rear Slip Plate Locking Mechanism	63
21.3 Airline Routing for Locking Turnplates and Rear Slip Plates.....	64
21.4 Rear LED Light Assembly: Exploded View	66
21.5 LED CONTROL BOX.....	68
22.0 CONSOLE ASSEMBLY	69
22.1 Electrical Panel	69
22.2 Console: Pneumatic & Filtering System.....	70
22.3 Console: Pneumatic & Filtering System - Locking & Light System (Optional).....	71
22.4 PNEUMATIC LIMIT SWITCH SCHEMATIC.....	72
22.5 Control Panel	74
22.6 Console Panel Assembly	75
23.0 POWERPACK ASSEMBLY	76
23.1 Powerpack Assembly.....	76
23.2 Manifold Parts List	78

1.0 OWNER / EMPLOYER OBLIGATIONS

1. The Owner/Employer shall ensure that lift operators are qualified and that they are trained in the safe use and operation of the lift using the manufacturer's operating instructions; ALI/SM 93-1, **ALI Lifting it Right safety manual**; ALI/ST-90 ALI **Safety Tips card**; ANSI/ALI ALOIM-2008, **American National Standard for Automotive Lifts - Safety Requirements for Operation, Inspection and Maintenance**; ALI/WL Series, **ALI Uniform Warning Label Decals/Placards**; and in the case of frame engaging lifts, ALI/LP-GUIDE, **Vehicle Lifting Points/Quick Reference Guide for Frame Engaging Lifts**.
2. The Owner/Employer shall establish procedures to periodically inspect the lift in accordance with the lift manufacturer's instructions or ANSI/ALI ALOIM-2008, **American National Standard for Automotive Lifts - Safety Requirements for Operation, Inspection and Maintenance**; and the Employer shall ensure that the lift inspectors are qualified and that they are adequately trained in the inspection of the lift.
3. The Owner/Employer shall establish procedures to periodically maintain the lift in accordance with the lift manufacturer's instructions or ANSI/ALI ALOIM-2008, **American National Standard for Automotive Lifts - Safety Requirements for Operation, Inspection and Maintenance**; and the Employer shall ensure that the lift maintenance personnel are qualified and that they are adequately trained in the maintenance of the lift.
4. The Owner/Employer shall maintain the periodic inspection and maintenance records recommended by the lift manufacturer's instructions or ANSI/ALI ALOIM-2008, **American National Standard for Automotive Lifts - Safety Requirements for Operation, Inspection and Maintenance**.
5. The Owner/Employer shall display the lift manufacturer's operating instructions; ALI/SM 93-1, **ALI Lifting it Right safety manual**; ALI/ST-90 **ALI Safety Tips card**; ANSI/ALI ALOIM-2008, **American National Standard for Automotive Lifts - Safety Requirements for Operation, Inspection and Maintenance**; ALI/WL Series, **ALI Uniform Warning Label Decals/Placards**; and in the case of frame engaging lifts, ALI/LP-GUIDE, **Vehicle Lifting Points/Quick Reference Guide for Frame Engaging Lifts** in a conspicuous location in the lift area convenient to the operator.
6. The Owner/Operator shall provide necessary lockout/tagout means for energy sources per ANSI Z244.1-1982 (R1993), **Safety Requirements for the Lockout/Tagout of Energy Sources**, before beginning any lift repairs and maintenance.

2.0 IMPORTANT SAFETY INSTRUCTIONS

1. **When using this lift, basic safety precautions should always be followed, including the following (where applicable):**
2. Read all instructions in this manual and on the lift thoroughly before installing, operating, servicing or maintaining the lift.
3. Care must be taken as burns can occur from touching hot parts.
4. Do not operate equipment with a damaged cord or if the equipment has been dropped or damaged – until it has been examined by a qualified service person.
5. Do not let a cord hang over the edge of the table, bench, or counter or come in contact with hot manifolds or moving fan blades.

6. If an extension cord is necessary, a cord with a current rating equal to or more than that of the equipment should be used. Cords rated for less current than the equipment may overheat. Care should be taken to arrange the cord so that it will not be tripped over or pulled.
7. Always unplug equipment from electrical outlet when not in use. Never use the cord to pull the plug from the outlet. Grasp plug and pull to disconnect.
8. Let equipment cool completely before putting away. Loop cord loosely around equipment when storing.
9. To reduce the risk of fire, do not operate equipment in the vicinity of open containers of flammable liquids (gasoline).
10. Adequate ventilation should be provided when working on operating internal combustion engines.
11. Keep hair, loose clothing, fingers, and all parts of body away from moving parts.
12. To reduce the risk of electric shock, do not use on wet surfaces or expose to rain.
13. Use only as described in this manual. Use only manufacturer's recommended attachments.
14. **ALWAYS WEAR SAFETY GLASSES.** Everyday eyeglasses only have impact resistant lenses, they are not safety glasses.
15. Inspect lift daily. Do not operate if it malfunctions or problems have been encountered.
16. Never attempt to overload the lift. The manufacturer's rated capacity is shown on the identification label on the power side column. Do not override the operating controls or the warranty will be void.
17. Before driving vehicle between the towers, position the arms to the drive-through position to ensure unobstructed clearance. Do not hit or run over arms as this could damage the lift and/or vehicle.
18. Only trained and authorized personnel should operate the lift. Do not allow customers or bystanders to operate the lift or be in the lift area.
19. Position the lift support pads to contact the vehicle manufacturers recommended lifting points. Raise the lift until the pads contact the vehicle. Check pads for secure contact with the vehicle. Check all arm restraints and insure they are properly engaged. Raise the lift to the desired working height.
20. Some pickup trucks may require an optional truck adapter to clear running boards or other accessories.
21. **NOTE:** Always use all 4 arms to raise and support vehicle.
22. **Caution!** Never work under the lift unless the mechanical safety locks are engaged.
23. Note that the removal or installation of some vehicle parts may cause a critical load shift in the center of gravity and may cause the vehicle to become unstable. Refer to the vehicle manufacturer's service manual for recommended procedures.
24. Always keep the lift area free of obstruction and debris. Grease and oil spills should always be cleaned up immediately.
25. Never raise vehicle with passengers inside.
26. Before lowering check area for any obstructions.
27. Before removing the vehicle from the lift area, position the arms to the drive-thru position to prevent damage to the lift and /or vehicle.
28. Do not remove hydraulic fittings while under pressure.

For additional safety instructions regarding lifting, lift types, warning labels, preparing to lift, vehicle spotting, vehicle lifting, maintaining load stability, emergency procedures, vehicle lowering, lift limitations, lift maintenance, good shop practices, installation, operator training and owner/employer responsibilities, please refer to "Lifting It Right" (ALI/SM) and "Safety Tips" (ALI/ST) and vehicle lift points for service garage lifting SAE J2184.

For additional instruction on general requirements for lift operation, please refer to "Automotive Lift-Safety Requirements For Operation, Inspection and Maintenance" (ANSI/ALI ALOIM).

Installation shall be performed in accordance with ANSO/ALI ALIS, Safety Requirements for Installation and Service of Automotive Lifts.



ATTENTION! This lift is intended for indoor installation only. It is prohibited to install this product outdoors. Operating environment temperature range should be 41 – 104 °F (5 – 40 °C). Failure to adhere will result in decertification, loss of warranty, and possible damage to the equipment.

+ 070126-Quadra-WLSIA01

SAFETY INSTRUCTIONS

If attachments, accessories or configuration modifying components that are located in the load path, affect operation of the lift, affect the lift electrical listing or affect intended vehicle accommodation are used on this lift and, if they are not certified for use on this lift, then the certification of this lift shall become null and void. Contact the participant for information pertaining to certified attachments, accessories or configuration modifying components.

www.autolift.org ©2007 by ALI, Inc. ALI / WLSIA01

SAVE THESE INSTRUCTIONS

Note: Some images in this manual are generic and may not resemble the lift you have purchased.

3.0 SAFETY WARNING DECALS

Automotive Lift Institute, Inc.

⚠ CAUTION	⚠ CAUTION
Lift to be used by trained operator ONLY.	Authorized personnel only in lift area.
©	©

The messages and pictographs shown are generic in nature and are meant to generally represent hazards common to all automotive lifts regardless of specific style.

Funding for the development and validation of these labels was provided by the Automotive Lift Institute, PO Box 85 Cortland, NY 13045.

Replacement label sets may be obtained from the original lift manufacturer and ALI's member companies. They are protected by copyright.

www.autolift.org © 2009 by ALI, Inc. ALI/WL200c

NOTICE	NOTICE
Read operating and safety manuals before using lift.	Proper maintenance and inspection is necessary for safe operation.
©	©

NOTICE	<p>The messages and pictographs shown are generic in nature and are meant to generally represent hazards common to all automotive lifts regardless of specific style.</p> <p>Funding for the development and validation of these labels was provided by the Automotive Lift Institute, PO Box 85 Cortland, NY 13045.</p> <p>Replacement label sets may be obtained from the original lift manufacturer and ALI's member companies. They are protected by copyright.</p> <p>www.autolift.org</p>
	<p>Do not operate a damaged lift.</p>
©	© 2009 by ALI, Inc. ALI/WL200c

WL200 Series Label Kit

⚠ WARNING	⚠ WARNING
Clear area if vehicle is in danger of falling.	Remain clear of lift when raising or lowering vehicle.
©	©

⚠ WARNING	⚠ WARNING
Keep clear of pinch points when lift is moving.	Keep feet clear of lift while lowering.
©	©

⚠ WARNING	⚠ WARNING
Do not override self-closing lift controls.	Chock wheel to prevent vehicle movement.
©	©

The messages and pictographs shown are generic in nature and are meant to generally represent hazards common to all automotive lifts regardless of specific style.

Funding for the development and validation of these labels was provided by the Automotive Lift Institute, PO Box 85 Cortland, NY 13045.

Replacement label sets may be obtained from the original lift manufacturer and ALI's member companies. They are protected by copyright.

www.autolift.org © 2010 by ALI, Inc. ALI/WL200w

4.0 SPECIFICATIONS

Maximum Capacity:	14 000 lbs	6363 kg
Overall Width (min-max):	92½" – 94½" Inches	2350-2400 mm
Overall Length:	270 Inches	6858 mm
Maximum Raised Height:	72 Inches	1829 mm
Minimum Lowered Height:	10 Inches	254 mm
Runway Width	26 Inches	660 mm
Maximum Wheelbase:	176 Inches	4470 mm
Lifting Time (approx.):	75 - 85 Seconds: depending on load	
Power Ratings:	230V, 1 Ph, 60Hz, 20A	
Maximum Operating Pressure @ Rated Load:	4600 PSI	
Air Supply requirements:	90 to 120 PSI	
Pneumatic Filtration Oil Type:	Snap-On #IM6 or Equivalent	
Hydraulic Oil Capacity:	Tank size: 4.0 gal	Lift capacity: 6.0 gal
Hydraulic Oil Type:	ISO 32 (10 weight) hydraulic oil	
Shipping Weight:	4870 lbs	2209 kg

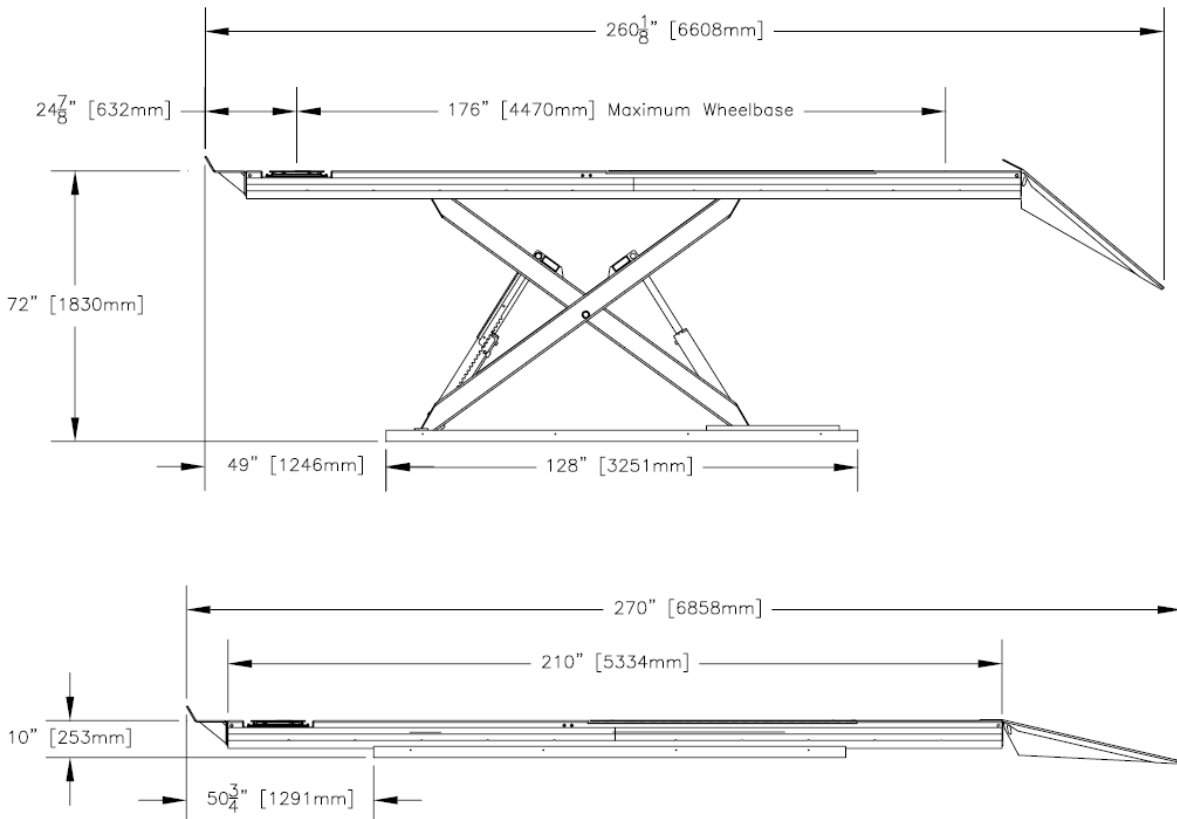

Figure 1 - Lift Dimensions

5.0 CONTENTS

The complete lift is contained in two (2) packages:

1. The main structural components are pre-assembled and packaged on top of each other.
2. The remaining parts are packed in a console/accessory box. Refer to the packing slip inside the accessory box for a list contents.

Components include:

- 1pc. – Left Side Main Frame Assembly: Runway, Scissors and Base Frame
- 1pc. – Right Side Main Frame Assembly: Runway, Scissors and Base Frame
- 1pc. – Console and Accessory box. (See accessory box list for contents)
- 1pc. – Grout container
- 1pc. – Customer care kit including manuals

6.0 TOOLS REQUIRED FOR INSTALLATION OF LIFT

- Hammer Drill or similar, 1/4" and 1/2" Concrete Drill Bits
- 4' Level
- SAE Wrenches and Sockets
- Hammer
- Pry Bar – 5' Long
- Chalk Line
- Tape Measure
- Side Cutters
- Screw Drivers
- Funnel
- Utility Knife
- Torque Wrench

Recommended:

- Laser Leveler
- Plumb Bob
- Impact Gun
- Boom and/or Engine Hoist
- 8' Sling
- Engine Crane

Note: Apply LOCTITE #242 on required fasteners where symbol is shown. If fasteners are removed reapply LOCTITE before re-installing.



7.0 INSTALLATION OVERVIEW

This is the order in which this installation is to take place:

1. Layout the Bay
2. Unpacking the Lift
3. Inspect the Lift
4. Connect Hydraulic Lines
5. Connect Air Lines
6. Connect Pneumatic Sensors
7. Connect Electrical
8. Initial Run of Lift
9. Level, Shim and Anchor
10. Install Accessories
11. Locking Front Turnplates and Rear Slip Plates / Light System (Optional)
12. Final Check
13. Clean
14. Train Customer on Operation of the Lift

IMPORTANT: Shop air must be connected to the inlet port at the FRL unit on the console, in order for lift to operate.

8.0 INSTRUCTIONS

When the lift arrives on site please read the owner's installation and operation manual completely. Check the contents to make sure no parts are missing before starting installation. Gather all of the tools listed and make sure that the instructions are fully understood before commencing with the installation.



IMPORTANT: It is the user's responsibility to provide a satisfactory installation area for the lift. Lifts should only be installed on level concrete floors with a minimum thickness of six inches (6") or 152 mm. Concrete must have a minimum strength of 4000 psi or 28 MPa and should be aged thirty (30) days prior to installation. Please consult the architect, contractor or engineer if doubt exists as to the strength and feasibility of the floor to enable proper lift installation and operation.

A qualified person should be consulted to address seismic loads and other local or state requirements.

It is the user's responsibility to provide all wiring for electrical hook-up prior to installation and to insure that the electrical installation conforms to local building codes. Where required, it is the user's responsibility to provide an electrical isolation switch located in close proximity to the lift that will enable emergency stop capability and isolate electrical power from the lift for any servicing requirements.

8.1 Flushmount Bay Layout

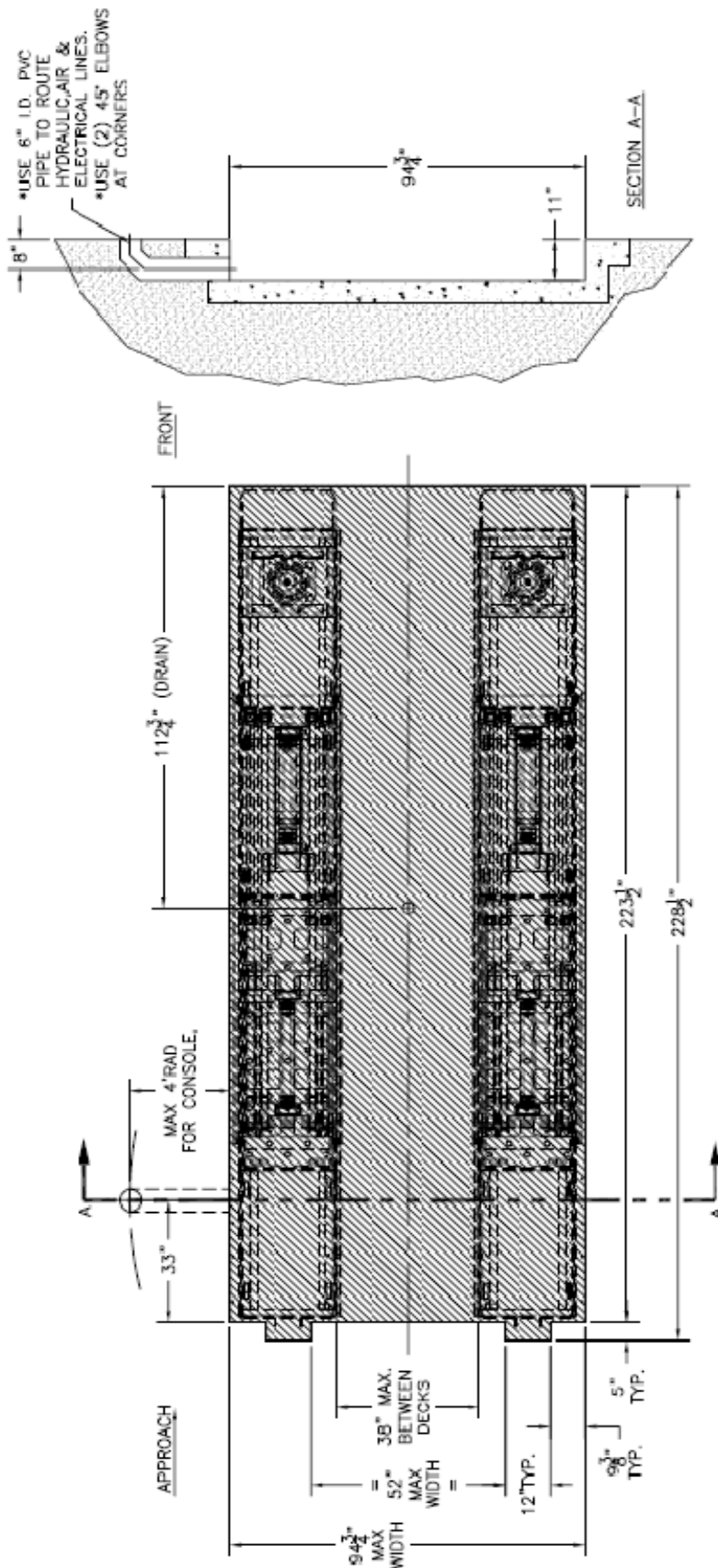

NOTE: Leave any additional room for any desired aisle or work area. Recommended clearance around the lift is a minimum of three (3) feet. Ensure clearance conforms to local building and fire codes.

Recommended overhead clearance is a minimum of twelve (12) foot ceiling providing 6 feet for the maximum lift height and 6 feet for the supported vehicle. For vehicles taller than 6 feet it is recommended that the user provides additional overhead clearance or a shut off mechanism to stop the lift from raising the vehicle too high.

Please contact customer service for latest installation diagram as it may change without notice.

Figure 2 - Typical Bay Layout (Flush Mount)

8.2 Surfacemount Bay Layout

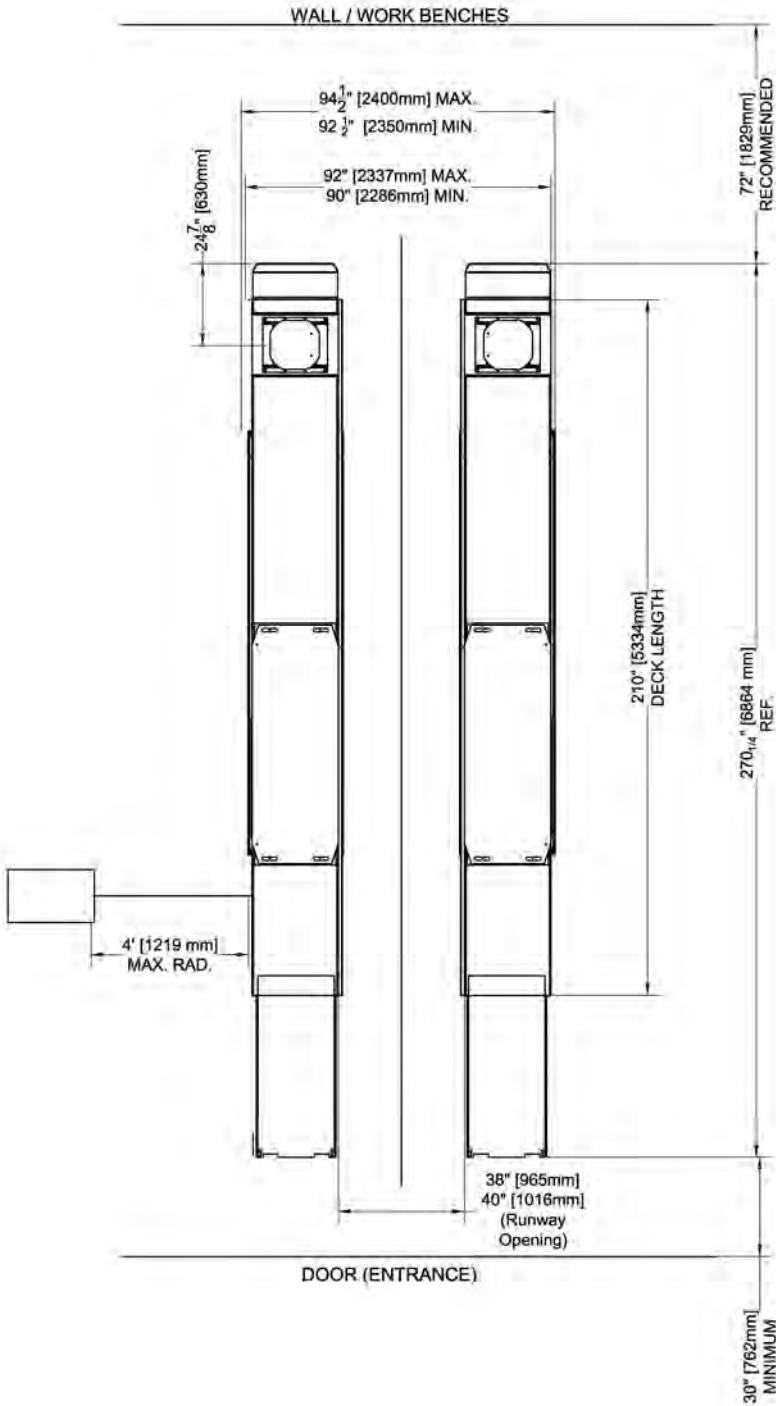

NOTE: Leave any additional room for any desired aisle or work area. Recommended clearance around the lift is a minimum of three (3) feet. Ensure clearance conforms to local building and fire codes.

Recommended overhead clearance is a minimum of twelve (12) foot ceiling providing 6 feet for the maximum lift height and 6 feet for the supported vehicle. For vehicles taller than 6 feet it is recommended that the user provides additional overhead clearance or a shut off mechanism to stop the lift from raising the vehicle too high.

Please contact customer service for latest installation diagram as it may change without notice.

Figure 3 - Typical Bay Layout (Surface Mount)

8.3 Baseframe Location

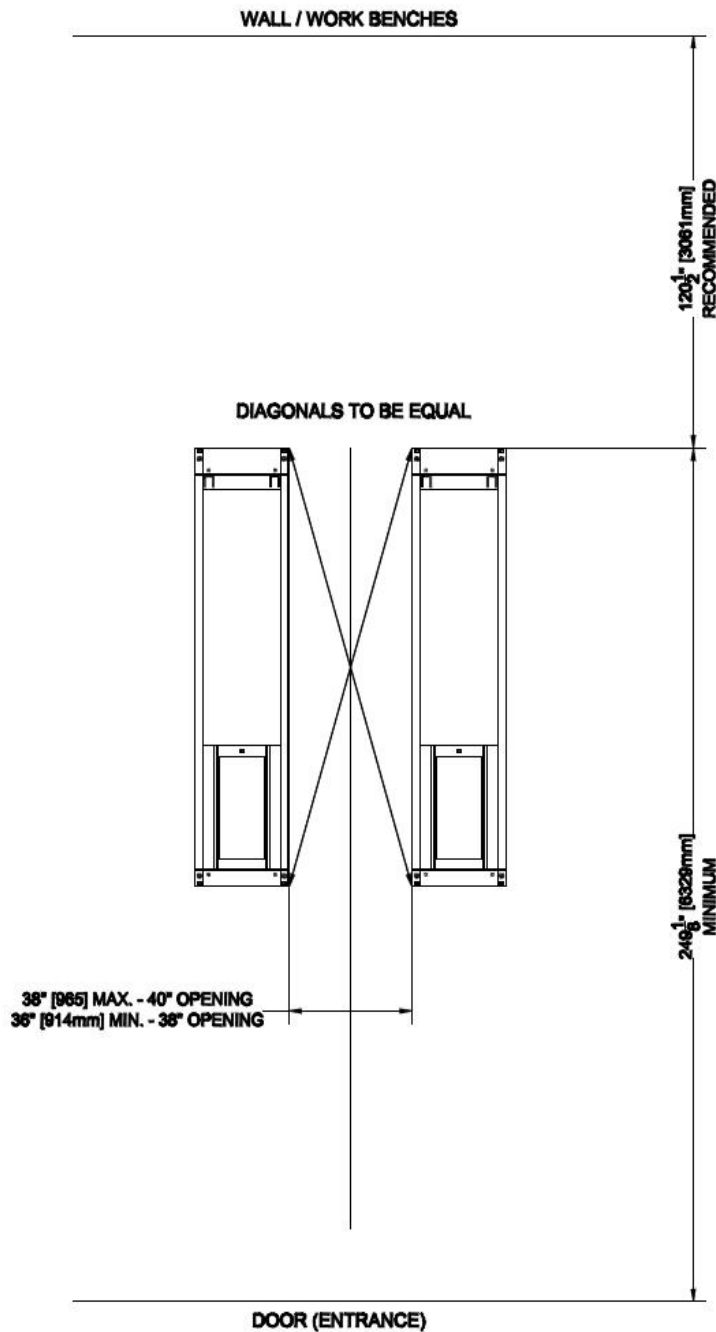

IMPORTANT: DO NOT CUT THE SHIPPING STRAPS HOLDING EACH SCISSOR ASSEMBLY TOGETHER UNTIL INSTRUCTED TO DO SO.

1. With reference to **Figure 3**, the installer should locate the most suitable location in the shop for the lift.
2. Snap a chalk line for the centerline of the lift ensuring that it matches the centerline of the bay door.
3. Measure and snap two (2) parallel chalk lines on either side the centerline for the inside edges of the baseframes. Refer to **Figure 4** for the dimensions necessary to provide the desired width between the two runways. A distance of 36" (914mm) between the baseframes will provide the standard width of 38" between the inside of the runways.
4. Measure and snap a chalk line parallel to the shop door for the front of the baseframes, a minimum distance of 249 1/8" (6329mm) is recommended.
5. Before proceeding, ensure that once the runways are installed adequate workspace will remain in front of the lift. Refer to the minimum requirements listed in the installation and operation manual of any alignment equipment as needed.

Figure 4 – Baseframe Locations



Refer to the minimum requirements listed in the installation and operation manual of any alignment equipment as needed.

8.4 Anchor Location

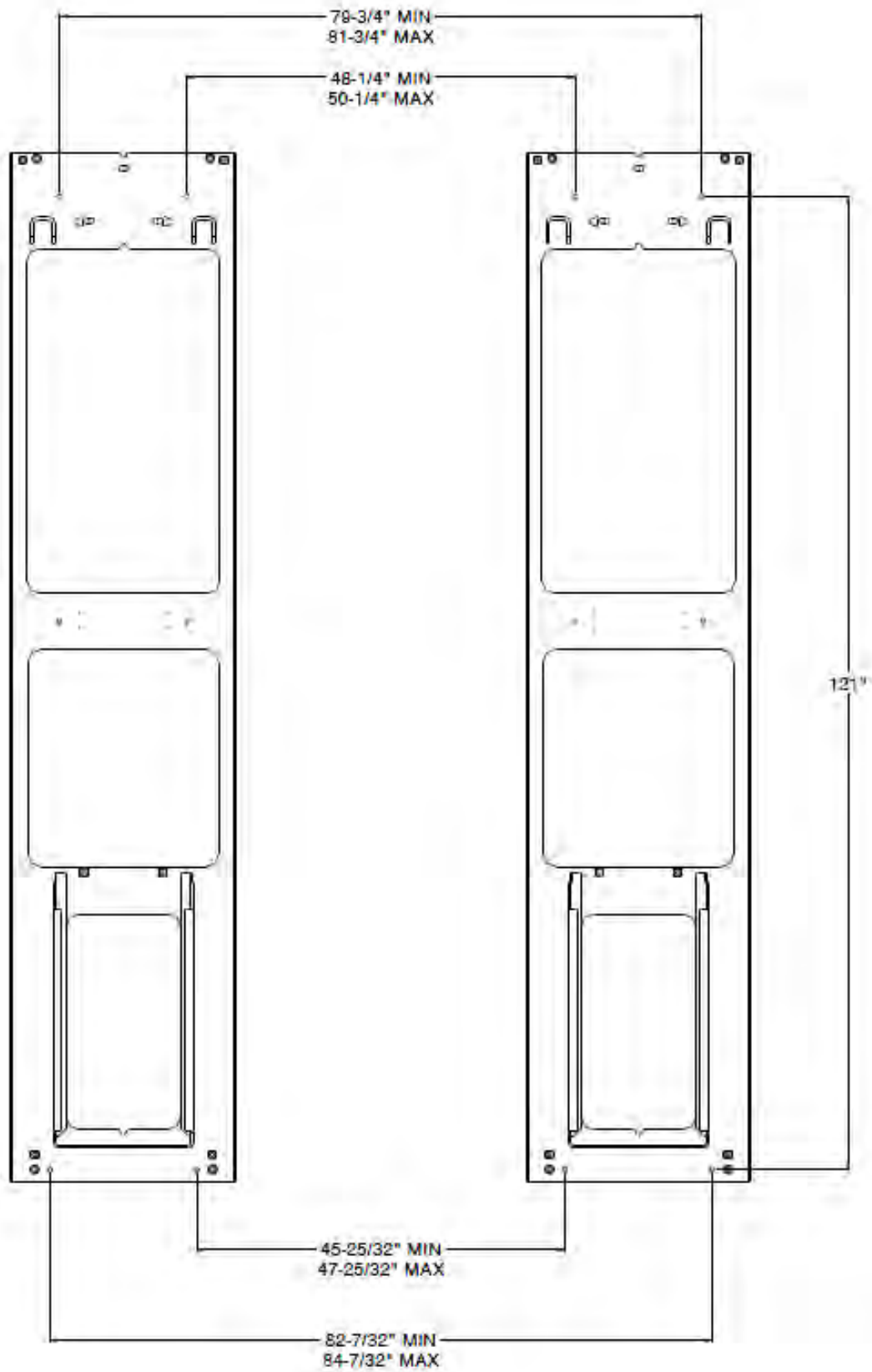

Figure 5 – Baseframe Locations

8.5 Unpacking the Lift

1. Unpack the console and place it in the desired location at the rear of the lift. The console can be placed on either the left or right hand side of the lift.
2. Unpack the runways and lay each baseframe along the chalk lines.



Do not remove the individual strapping on the runways until they have been positioned on the chalk lines.

3. Position the baseframes on chalk lines, and ensure that the runways are parallel. Ensure that both the inside dimensions (front and back) of the baseframes as well as the diagonal distances are equal.
4. Remove the remaining packing straps, and remove the hydraulic hoses, polytubes and proximity switch wires from under the deck. Hoses and wiring are located under the rear portion of the deck and are factory pre-installed.
5. Inspect lift for damage or any irregularities. If any are found, please contact customer service before proceeding.

Note: Do not pull excessively on the hoses and wiring as it may strain the connections to the baseframe.

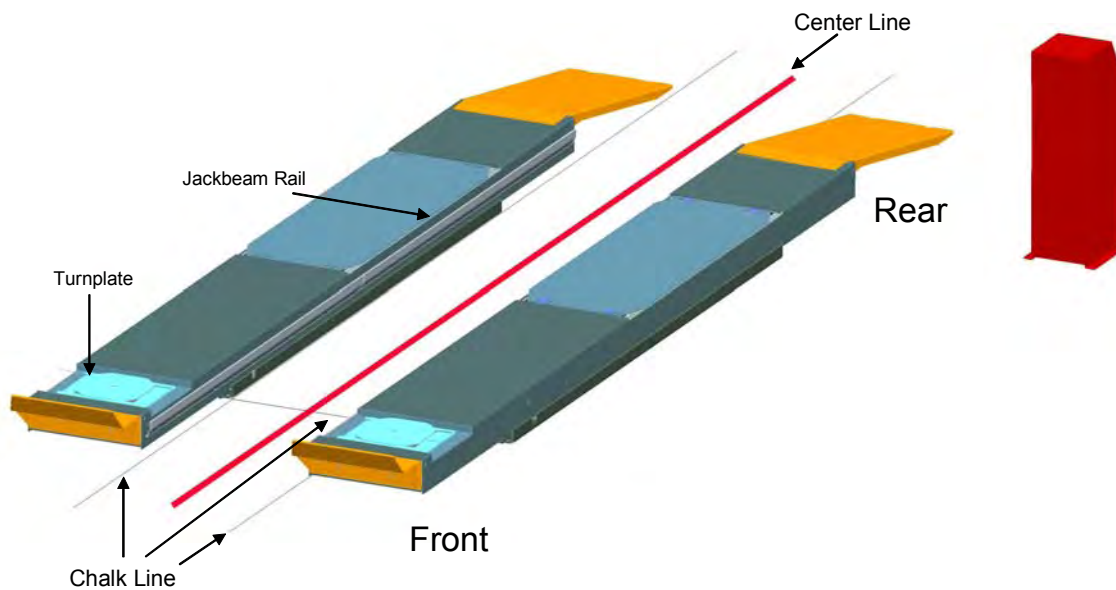

Ensure that the turnplate pockets are at the front, and that Jack Beam rails for each runway face each other.

8.6 Hydraulic Connections

1. Open the front and rear access covers of the console.
2. Unravel all hoses, air lines, and sensor cables from each runway and connect the hydraulic lines as shown in Figure 5. Save the caps from the hydraulic lines for capping other fittings mentioned in the next step.

- **Always make sure that the connections are clean to avoid contaminating the hydraulic system.**
- **Do not kink hydraulic hoses or air lines.**
- **Do not remove hydraulic fittings while under pressure**

3. The primary supply lines and equalizing lines from each runway are:

Left Side (L):

CL

EQL + 22718

(“C” for “Cylinder” and “EQ” for “Equalize”)

Right Side (R):

CR

EQR + 22719

4. The 3/8” polytube return lines in the baseframes should be joined inside the console using a 3/8” “T” connector (**Figure 6**) from the hardware kit. To connect the “T” connector to the tank, cut off approximately 6” to 8” (152.4mm to 203.2mm) from either polytube supplied. Next, connect the other end of the tube to the pump connection marked T (Tank) (**Figure 7**)



Figure 6 - "T" Connector

FRONT

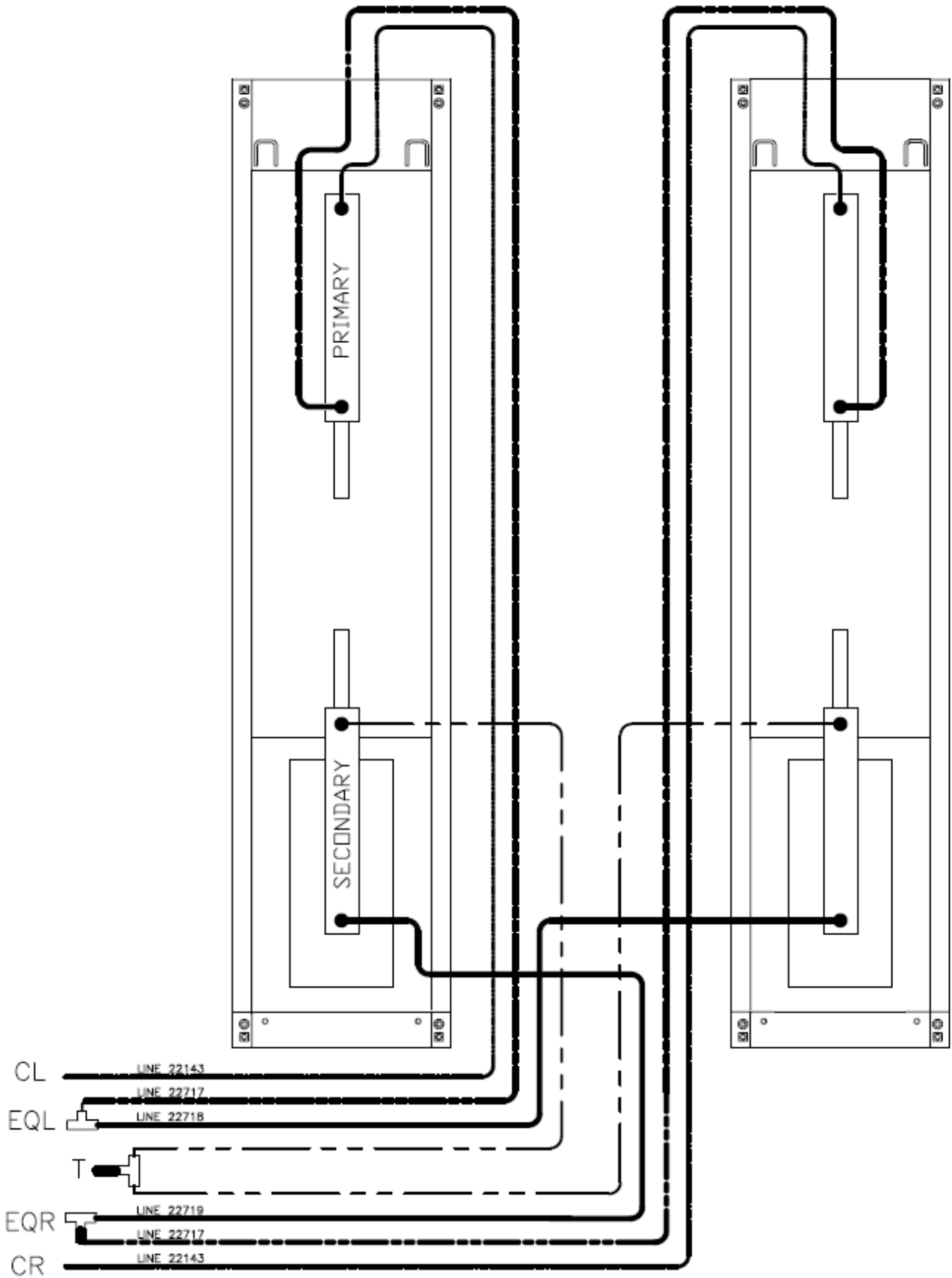

Figure 7 - Hydraulic Connections

8.7 Air Safety and Auxiliary Air connections



WARNING! WEAR SAFETY GOGGLES AND PRACTICE CAUTION WHILE WORKING WITH COMPRESSED AIR.

1. Uncoil the 1/4" polytube under each deck that is connected to the air release cylinder. Route this line to the 'y' connector in the console.
2. Locate the FRL. The hardware is preassembled on the FRL, remove the two nuts ensuring the screws do not fall.
3. Assemble the FRL unit to the side of the console with the hardware provided on the FRL unit. Orient with supply port to the rear of the console and 90° fitting lined up with the hole in the side of the console.
4. On the inside of the console, assemble the nuts but leave loose, engaging 2 threads.
5. Rotate the FRL such that the 90° fitting passes through the hole. Secure the T-fitting inside the console to the 90° fitting with a wrench.
6. Tighten the nuts to secure the FRL
7. The 3/8" polytube for the auxiliary air connections is coiled under the right side runway. Route this hose to the console and connect it to the tee fitting inside the console.
8. A 3/8" NPT fitting (**not supplied**), is needed to connect shop air supply to the Air Filter / Regulator/ Lubricator Unit. Connect air line to the FRL unit located on the outside of the console.

IMPORTANT: Shop air must be connected to the inlet port at the FRL unit on the console, in order for lift to operate.

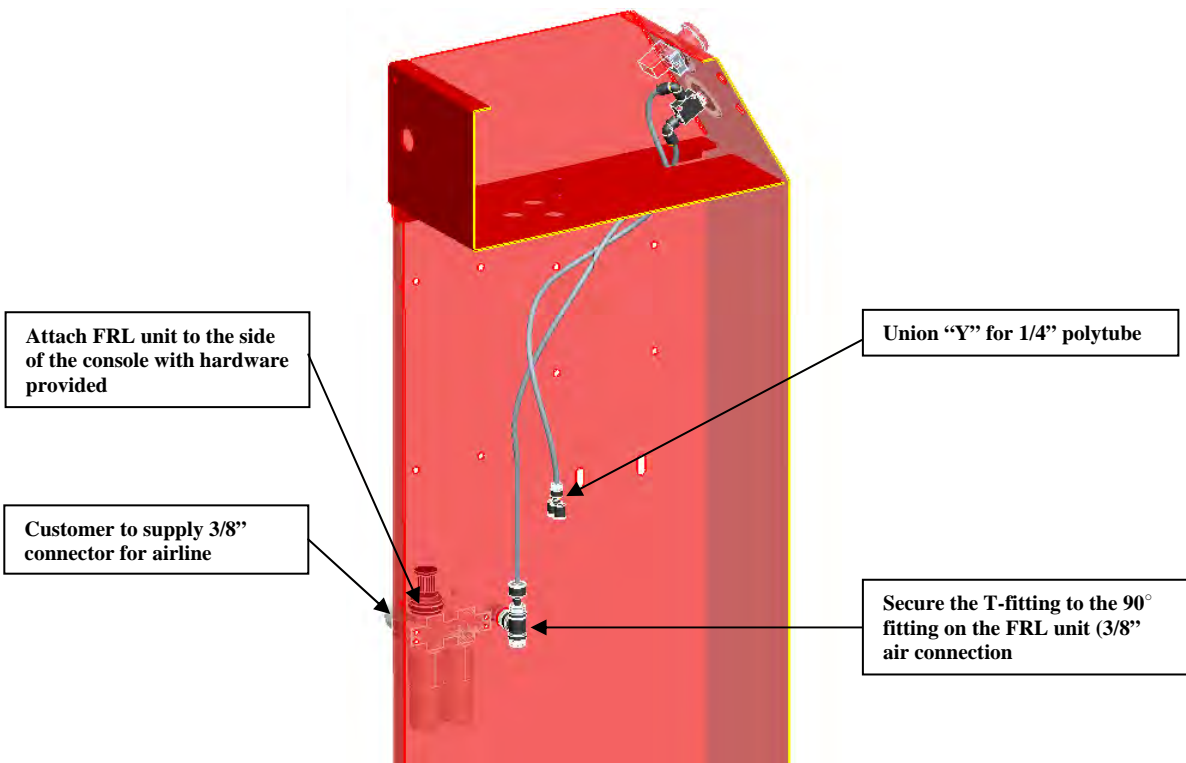



WARNING! REPLENISH THE LUBRICANT AFTER RELEASING THE INLET PRESSURE. LUBRICATION CANNOT TAKE PLACE UNDER A PRESSURIZED CONDITION

9. Unscrew the lubricator bowl by turning it in a counter-clockwise direction
10. Fill the Lubricator Reservoir with **Snap-On Air Motor Oil #IM6** or Equivalent. Oil supply to the lubricator should be less than the upper limit of the oil level
 - **The console is equipped with an Air Filter / Lubricator / Regulator to ensure a clean air supply is provided to the safety release cylinders, jackbeams, and any other air tools connected to the lift. The Air Regulator should be set between 90-120 psi.**



IMPORTANT! OIL OTHER THAN ABOVE MAY CAUSE DAMAGE AND DRIPPING FAILURE

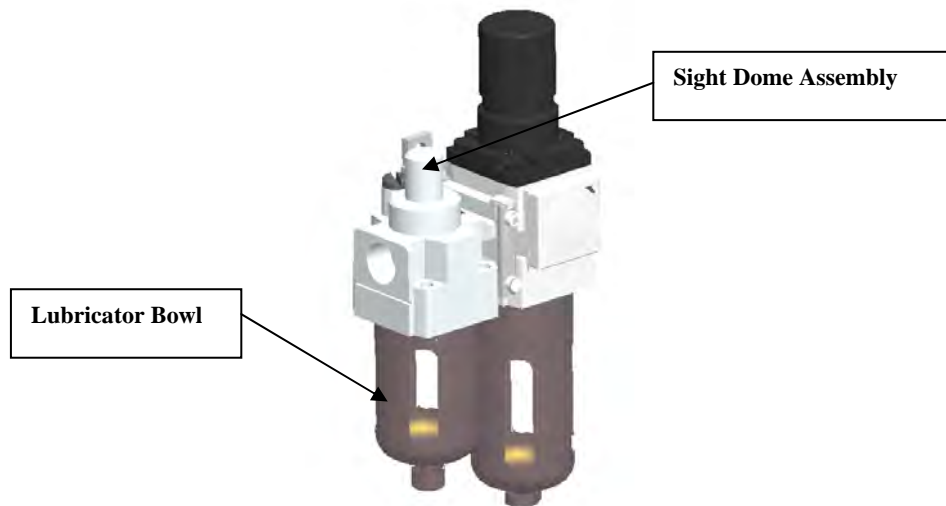

11. Screw in the lubricator bowl
12. Slowly pressurize the system
 - **Note: The regulator has been set to operate at 90PSI**
 - **Note: The sight dome assembly has already been set to provide 3-5 drips per minute.** Check the sight dome assembly and verify that oil drips.
13. Check the air system for any leaks.

FRONT

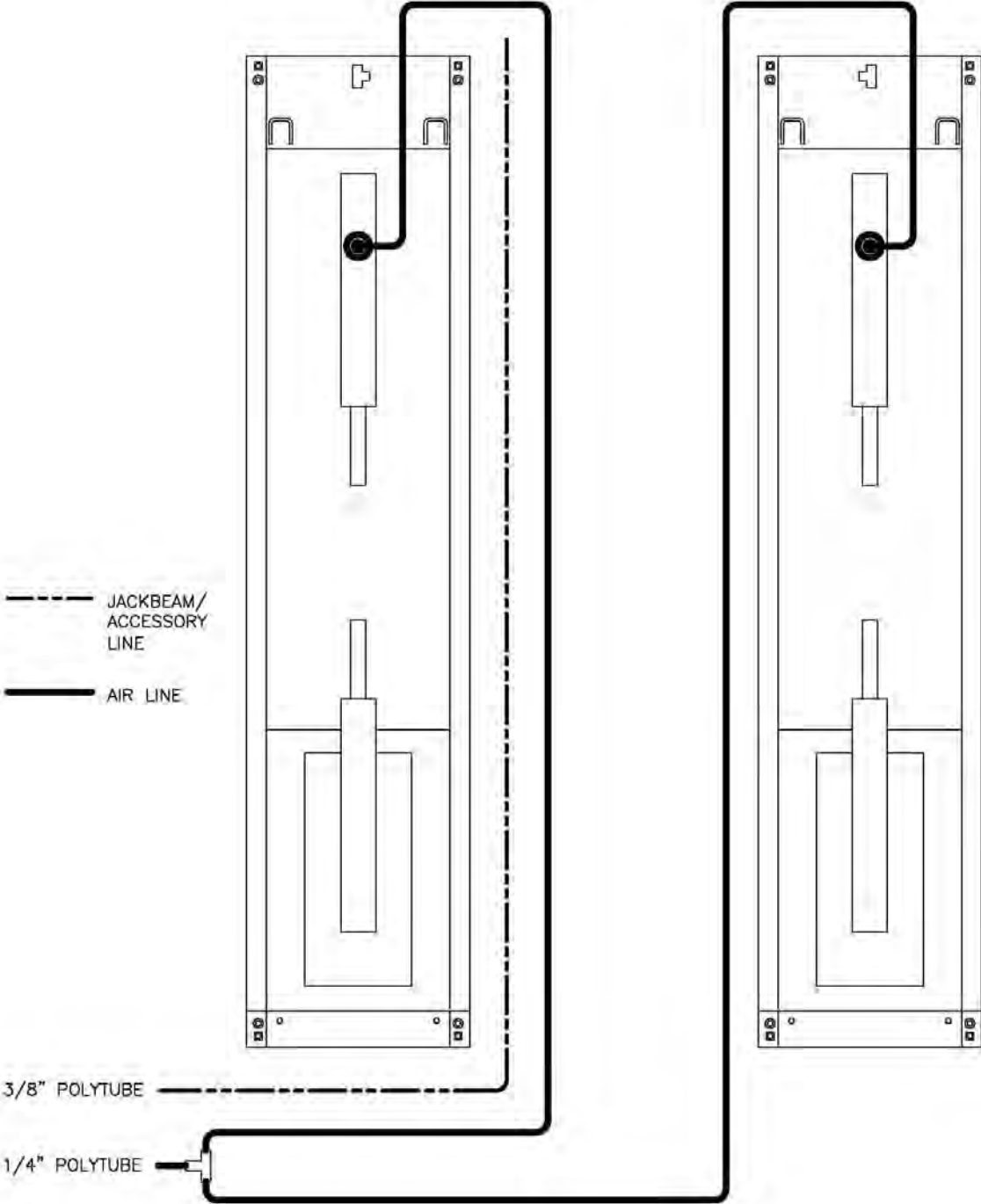

Figure 8 - Air Safety & Auxiliary Air Connections

8.8 Pneumatic Sensor Connections

There are three (3) pneumatic limit switches on this lift. Each runway is outfitted with an individual equalizing pneumatic switch mounted on a bracket located under the front of the runway. The third pneumatic switch, used for upper limit detection, is located under the rear slip plate area on the left scissor assembly.

Each Pneumatic Switch has a supply line and return line.

1. The equalizing pneumatic switch and upper limit pneumatic switch on the left side scissor assembly are supplied by the 3/8" jackbeam air line (Figure 9a).
2. The equalizing pneumatic switch on the right side deck assembly is supplied by the main air supply in the console. Connect the supply line labeled "EQ. SUPPLY" as shown in Figure 10.

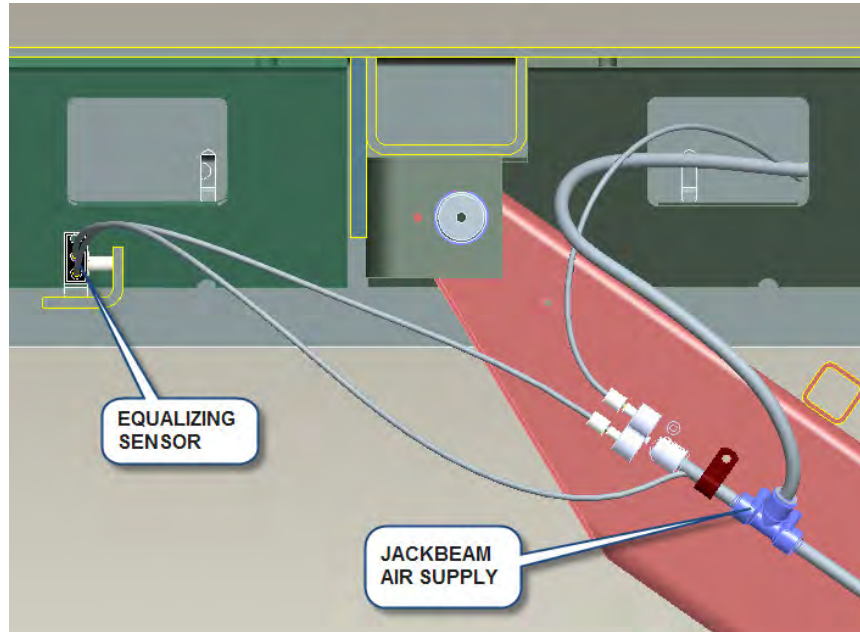

Figure 9a - Equalizing Pneumatic Switch. (View under LS Deck - Front)

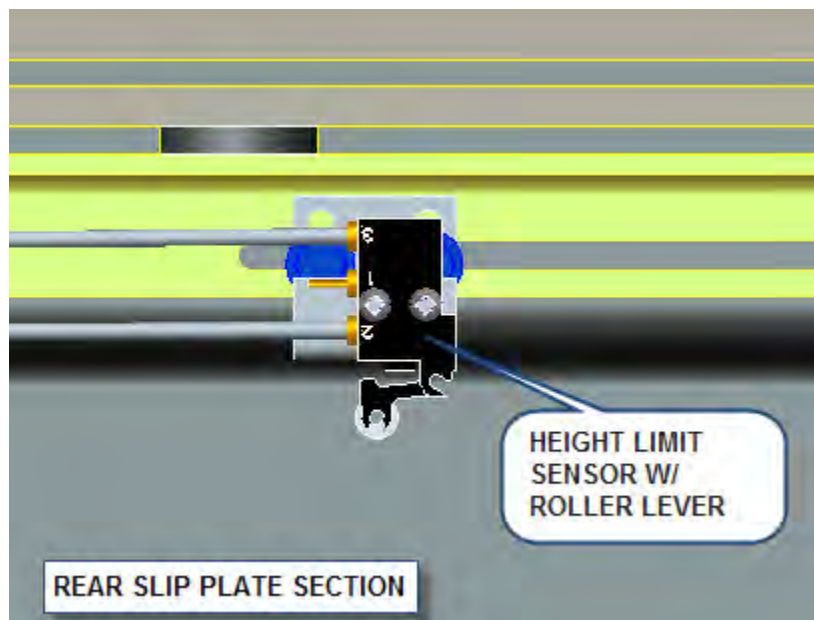

Figure 9b - Upper Limit Pneumatic Switch. (View under LS Deck - Rear)



Figure 10 – Right Side Equalizing Limit Pneumatic Switch (Console)

3. The two (2) equalizing pneumatic switch return lines, labeled “EQ. RETURN”, are connected to a union ‘Y’ fitting in the console (Figure 11).
4. The upper limit pneumatic switch return line, labeled “LMT RETURN”, is connected to the pressure switch fitting in the console (Figure 11).

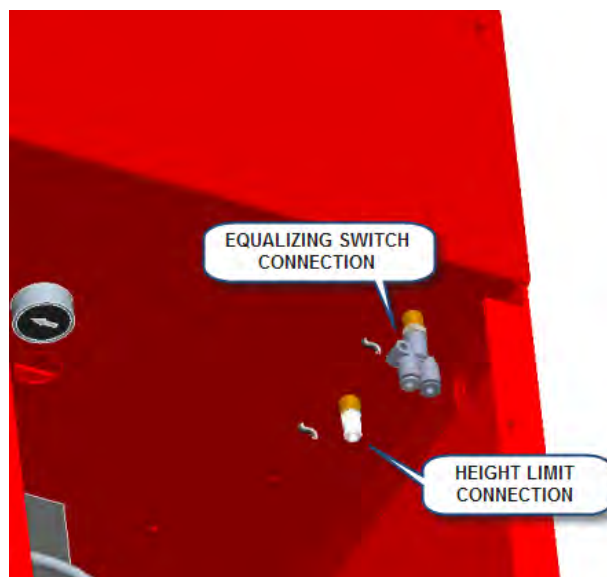

Figure 10 – Pneumatic Switch Return Line Connections (Console)

8.9 Electrical Connections



DANGER ! – Ensure that electrical connections are completed by a licensed electrician. Electrical shocks can cause serious injury or even death.

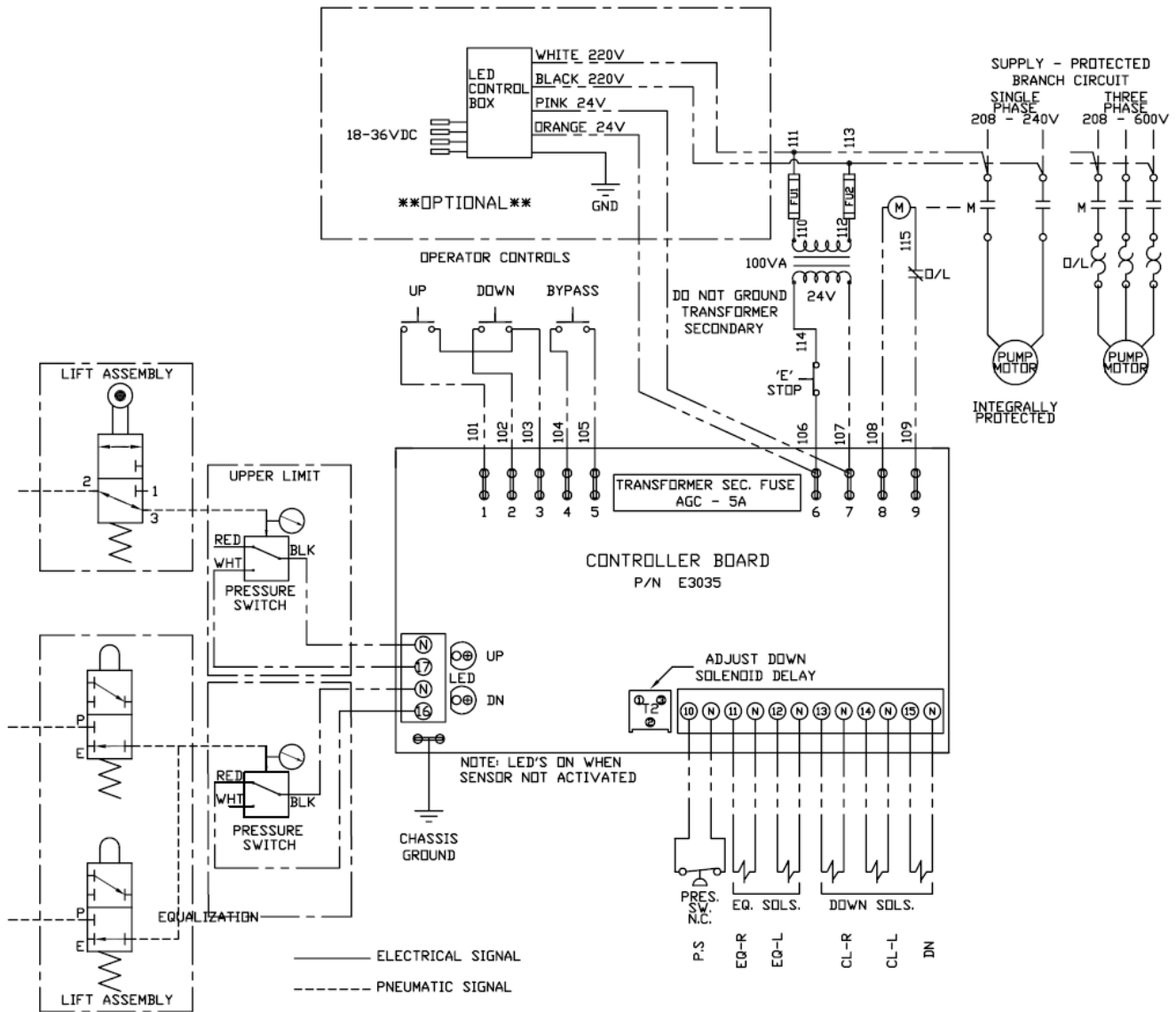

Figure 12a - Console Circuit Connections

** Optional for locking and lights. See next page for electrical diagram of LED driver box.

NOTE: Overload fuse does not come with single phase power unit

NOTE: Optional Voltage and Phase power units will include separate wiring diagrams.

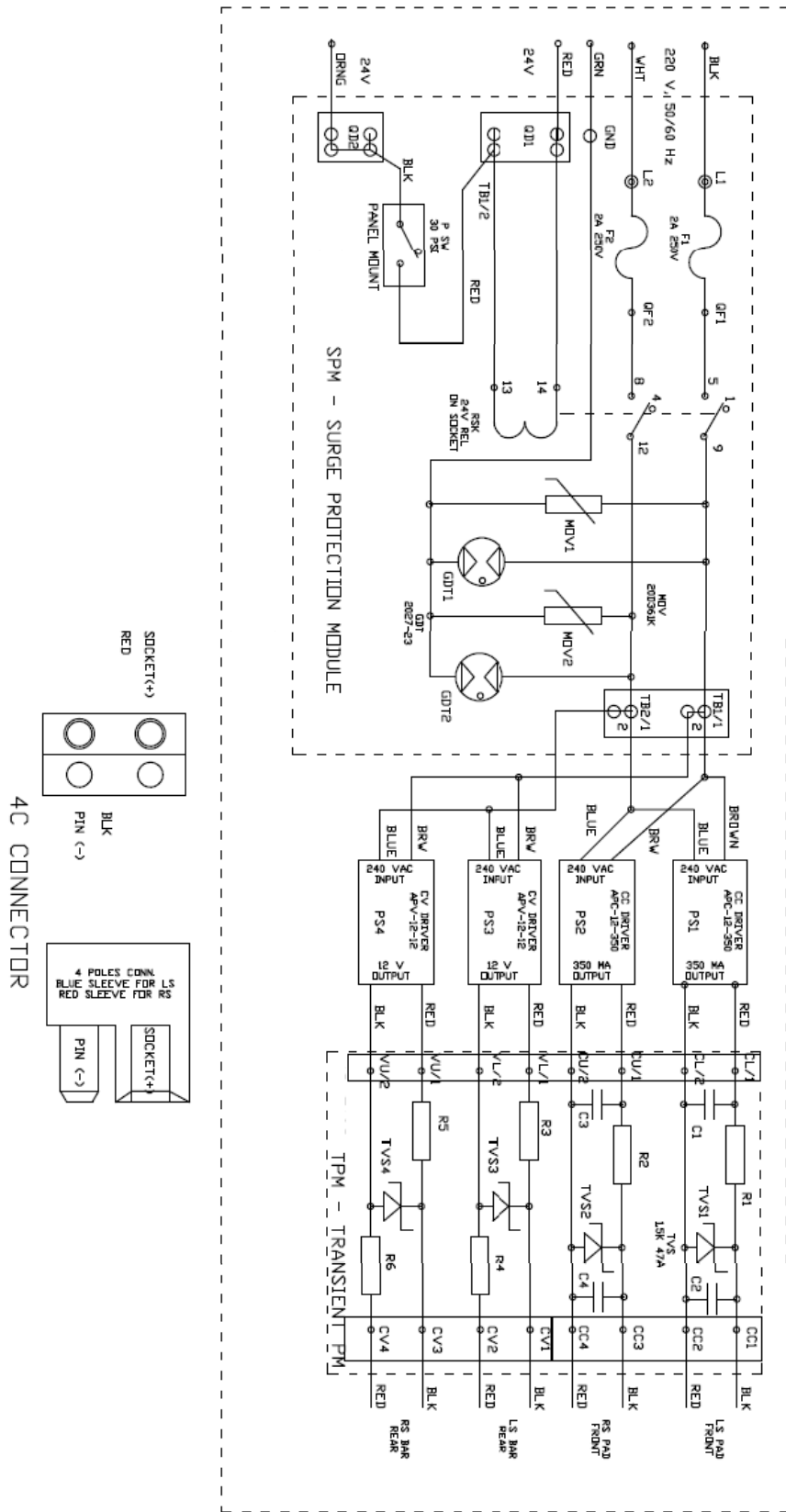

Figure 12b - **Optional: LED Driver Box Circuit Connections

8.10 Initial Operation

1. Add hydraulic fluid to reservoir (ISO 32 10wt). Oil capacity for the lift is approximately 6 gallons.

IMPORTANT: Shop air must be connected to the inlet port at the FRL unit in the console, in order for lift to operate.

2. Raise lift to 2 ft, lower and repeat 3 to 4 times, using “UP” and “DOWN” controls on the front of the console.

*** During this stage the lift is not yet full of oil. During the following steps, one side of the lift may raise higher than the other.**

3. Using the “BYPASS” button inside the console, start raising the lift to the last lock position as shown in Figure 13.

Monitor the fluid level during this procedure. At approximately half way, add 10 liters of oil to the reservoir. Continue to raise the lift.

NOTE: Ensure the gauges inside the console are monitored and pressure does not reach 1000 psi. If 1000 psi is reached, lower the lift onto the locks to relieve the pressure. Continue to raise the lift until both sides of the lift are on the last lock position. (Figure 13)

IMPORTANT: The unit must be on the last locking position to bleed the lift.

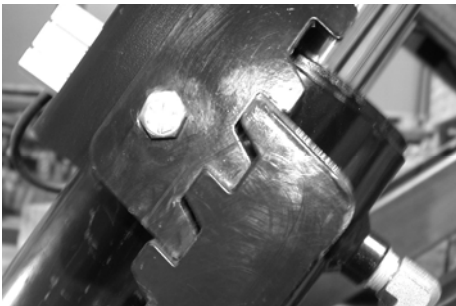

Figure 13-Safety lock position for bleeding.

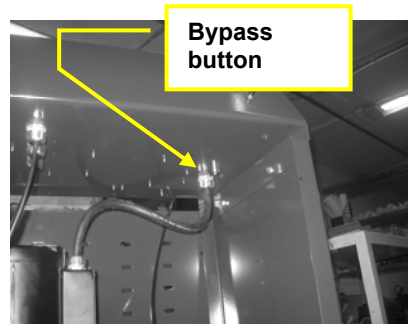

Figure 14- Location of bypass button.

4. BLEED THE SYSTEM: Once the lift is placed on the last safety position, remove the polytube return lines, at the tee fitting (Figure 6) and place them into a funnel over the reservoir. Press the bypass button until a clear stream of oil is flowing from the return lines. Release the bypass button and wait for 5 -10 seconds and continue to bleed. Repeat this “wait and bleed” procedure 5 times or until air is no longer visible in the return lines. Connect polytube lines back to the tee fitting.

5. RELEASE THE SAFETY LOCKS: Place a rag or drip pan directly under the secondary cylinder and remove the 90 deg. push lock fittings on the top of the secondary cylinders (see Figure 15). Cap the port using the plugs provided.



6. Holding the air safety release button on the console, raise the lift using the “BYPASS” button until the safety locks disengage. **DO NOT BUILD PRESSURE OVER 1000 PSI.**
7. Lower the lift to the next safety lock. Remove the plugs and reinstall the 90 deg push lock fittings. Lower the lift to a comfortable working height and continue the installation.



Figure 15- Remove fitting.

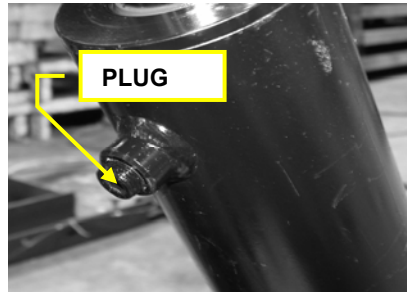

Figure 16- Cap port using plug provided.

8.11 Equalizing Function Check

Check:

To verify that the pneumatic switches are functioning, remove the rear panel on the console and locate the five (5) Din Connector/Solenoid assemblies; (four (4) on manifold block and one (1) on the pump). When the lift reaches its fully lowered position, these din connectors will emit a red light for 3 to 5 seconds.

If this does not occur, check the pneumatic connections at the sensors and at the console.

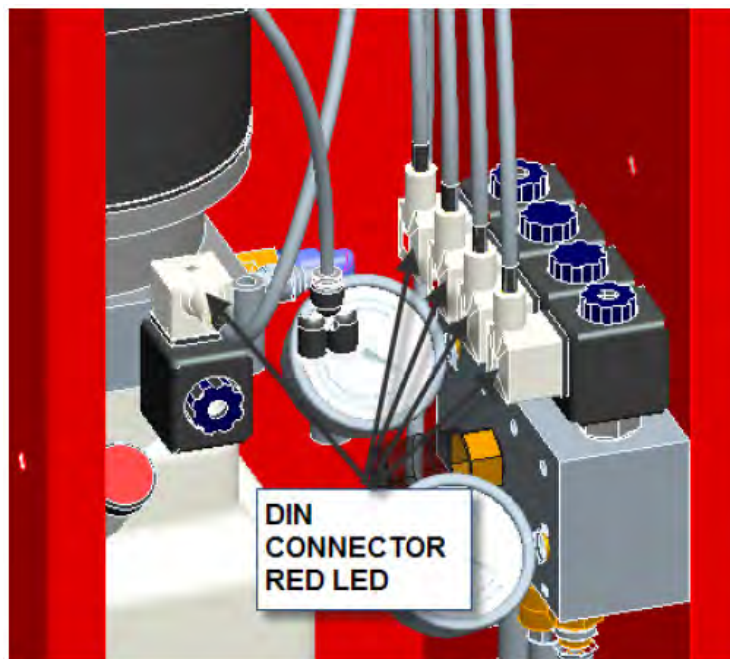

8.12 Maximum Height Adjustment

The lift has been pre-adjusted at the factory to a 72" working height. If a lower height limit is required, the system can be adjusted to a minimum of 43".

1. Raise lift to full height by pressing the up button (do not press the by-pass button).
2. The limit switch (see Figure 16) should automatically stop the lift once the 72" working height (bottom of baseframe to top of runway) is reached.
3. Lower the lift to the desired working height ensuring the safety locks can be disengaged.
4. Loosen the 1/4" adjustment bolts and slide the limit switch and bracket assembly towards the scissor cross-tube until the roller lever on the switch is fully depressed. **NOTE: Switch must be installed in front of the cross-tube.** Hold in place and tighten 1/4" bolts.

CHECK: Lower the lift to the ground, then raise until the lift stops. Perform this function a few times to verify the upper limit is set correctly.

NOTE: Make sure locks can be disengaged at the maximum or desired height.

UPPER LIMIT PNEUMATIC SWITCH

LOCATION: Underside of Driver Runway.

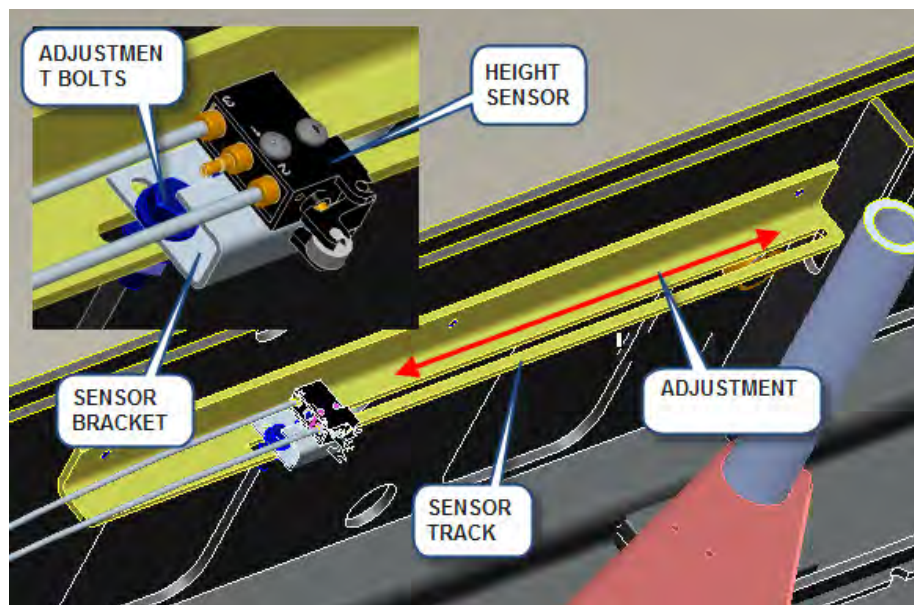

Figure 17 - Upper limit proximity sensor

NOTICE

The limit switch should never allow the working height to be above 72". If the automatic stop height is above 72", damage or failure of the hydraulic seals in the cylinder can occur.

8.13 Level and Support



NOTICE - CORRECT LEVELING IS IMPORTANT TO ENSURE THE PROPER OPERATION OF THE LIFT. TAKE PRECAUTIONS TO ENSURE ACCURATE LEVEL READINGS WHEN PERFORMING THIS PROCEDURE

Side-to-side leveling measurements should be taken off the baseframe, and measurements should be taken on each baseframe as well as between the two baseframes. Front-to-back level measurements should be taken on the runways.

1. Press the up button and raise the lift to the fully extended operating position. Check the location of the baseframes compared to Figure 4, and make minor adjustments as required.
2. Level the baseframes using the 5/8" leveling bolts provided at each of the four (4) corners.
3. Use shims provided to support under glide block area of baseframe and under front hinges. See **Figure 18**.

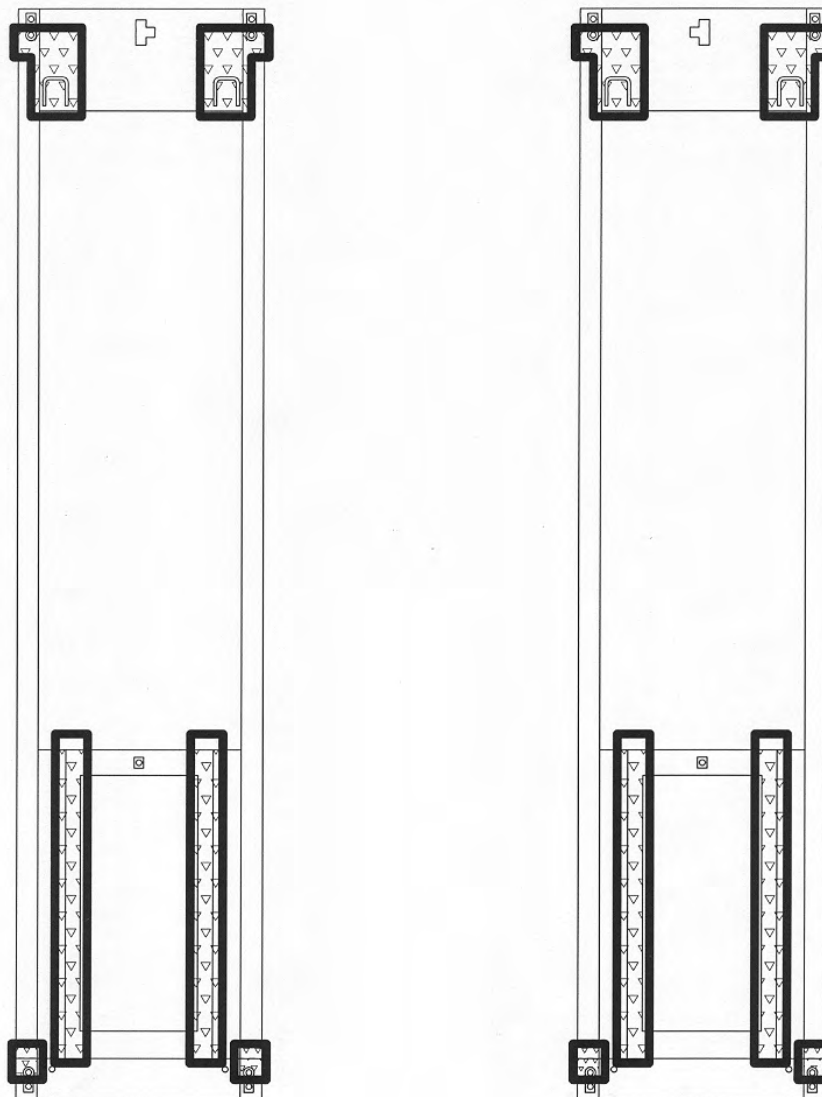

Figure 18 - Shimming

4. Verify that the baseframes are level side-to-side and that the runways are level front-to-back. The front turnplate and rear slip plate are the areas of interest. Check that the spacing between the runways is as desired, and that this spacing is equal at both the front and rear of the lift. Check that the diagonal measurements between opposite corners of the baseframes are equal. Lower and raise the lift and repeat these measurements.
5. Adjust the 3/4" support bolts on the four (4) corners of the baseframes to level the runway at fully collapsed position.
6. Once lift is level, back off 5/8" leveling bolts so that the base is firmly sitting on the shims. Re-check to make sure the lift is still level and shims are holding properly.
Note: These bolts must be removed once the shims are installed under the base correctly (same as the center bolt on the base).

8.14 Anchoring Procedure



CAUTION! WEAR SAFETY GOGGLES AND PRACTICE CAUTION WHILE DRILLING CONCRETE.

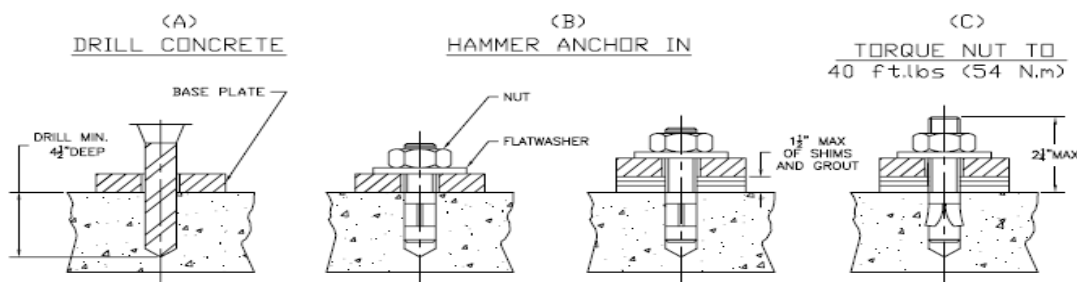

Figure 19 – Anchoring

1. Lower the lift and measure the distance between the Jackbeam rails at front and rear of the lift.
2. Raise the lift to full height and repeat the measurements, and ensure there are no differences.
3. Using a rotary hammer drill and a 1/2" concrete bit, drill through the floor at each of the four (4) anchor bolt locations on each of the base frames. Refer to **Figure 5** for locations & **Figure 19**.
4. Assemble the nut and washer onto the 1/2" x 4 1/2" long wedge anchor bolts supplied. A minimum of six threads must be visible below the surface of the nut.
5. Clean out the drilling dust from the holes and hammer in the anchors until they make contact with the baseplate. **Hand tighten all anchor bolts.**
6. Torque all anchor bolts to 40 ft-lbs.
7. Position the console in the final desired location. Using a rotary hammer drill and a 1/4" concrete bit, drill and anchor the console to the floor using the Nail in Anchors located in the hardware kit.
8. Use the line covers to protect all cables, hoses, and wiring running to the lift. Using a rotary hammer drill and a 1/4" concrete bit, drill and anchor the line covers using the nail in anchors located in the hardware kit.

If anchor bolts do not tighten to 40 ft-lbs. OR project more than 2 1/4" above the concrete surface, the concrete should be replaced by an appropriate concrete pad.

8.15 Grouting Procedure (Optional)

1. Pour grouting under the load area of each base frame as shown in **Figure 20**. Ensure that grout is evenly distributed under the frame and finish the edges with a 45 degree chamfer. Refer to specific grouting instructions on the package. Leave a drain area to allow any liquids to escape.
2. **GROUTING MUST FULLY CURE BEFORE PROCEEDING.** Do not operate the lift while grout is curing. Refer to instructions on the package for recommended cure times. [Non-Shrink Grout (3000psi min. in 24hrs, 7000psi min. in 30 days)]

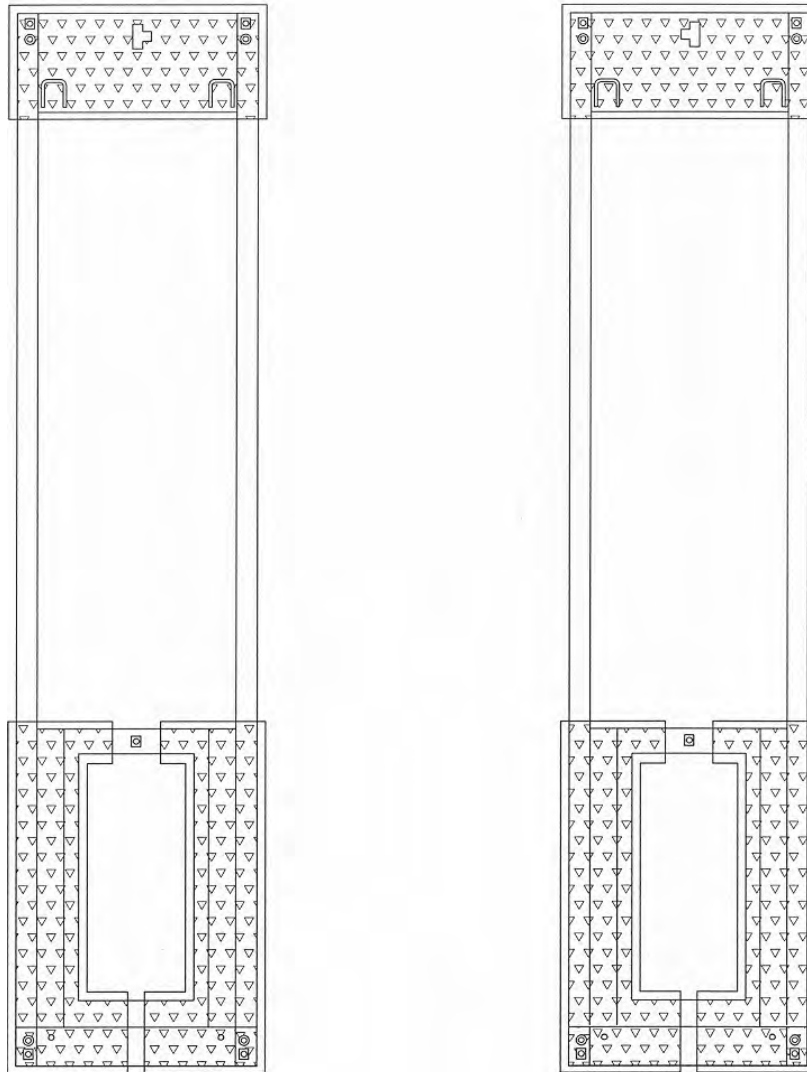
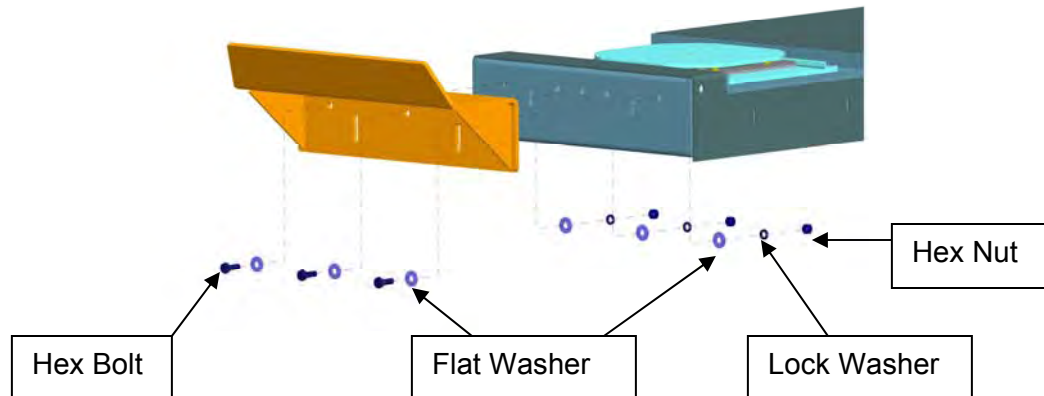

Figure 20 - Grouting Locations

9.0 ACCESSORY INSTALLATION

1. Install the front runway stops located in the accessory box using the ½" hex bolts, washers, lock washers, and hex nuts located in the hardware kit.



The runway stops are designed as a secondary means to restrain a vehicle from inadvertently rolling off the runways. Property damage and physical injuries may occur if this warning is not adhered to.

2. Install the mounting bracket and then the rear approach ramps using the Approach Ramp Pins located in the accessory box, and the hex head bolts, flat washers, lock washers, hex nuts and cotter pins located in the hardware kit.

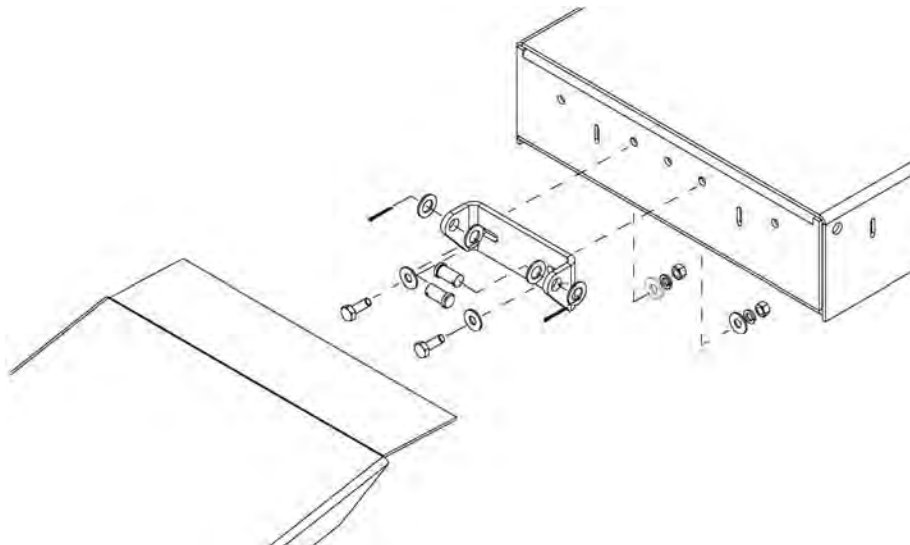

3. Install Jackbeams with reference to the Jackbeam user manual.

4. Position the moveable workstep in the desired location. There are slots along the span of each runway where the workstep can be mounted. When not in use, the workstep can be stored under the front section of the runway.

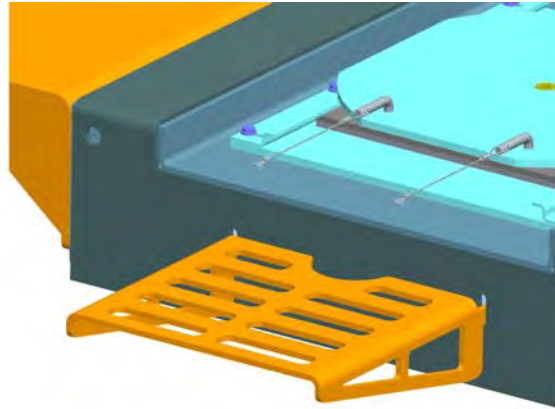

WARNING!! ENSURE THE WORKSTEP IS FULLY ENGAGED PRIOR TO USE. IF MORE THAN ONE WORKSTEP IS IN USE, DO NOT TRY TO STEP ACROSS OR JUMP FROM ONE STEP TO ANOTHER. NEVER USE THE WORKSTEP WHILE THE LIFT IS IN OPERATION. SERIOUS INJURY COULD RESULT FROM IMPROPER USAGE OF THE WORKSTEPS.



WARNING! WORKSTEP MAXIMUM CAPACITY IS 250 LBS.

WARNING! FOR FLUSHMOUNT INSTALLATIONS ENSURE WORKSTEP IS REMOVED BEFORE RAISING OR LOWERING THE LIFT.

5. *Required for **Flushmount** installation only.*

Position the filler angle (1-3038CN) along side of pit, as shown below.

Ensure top of angle is flush with the top of the concrete. Using the angle as a template, mark holes for drilling.

Drill 1/2 holes in concrete and secure filler angle with 1/2 Wedge Anchors provided.

Repeat for the remaining 3 angles along first side and perform the same procedure for the opposite side of the pit

* If a short deck assembly is being installed, cut the 4th filler angle to the desired length.

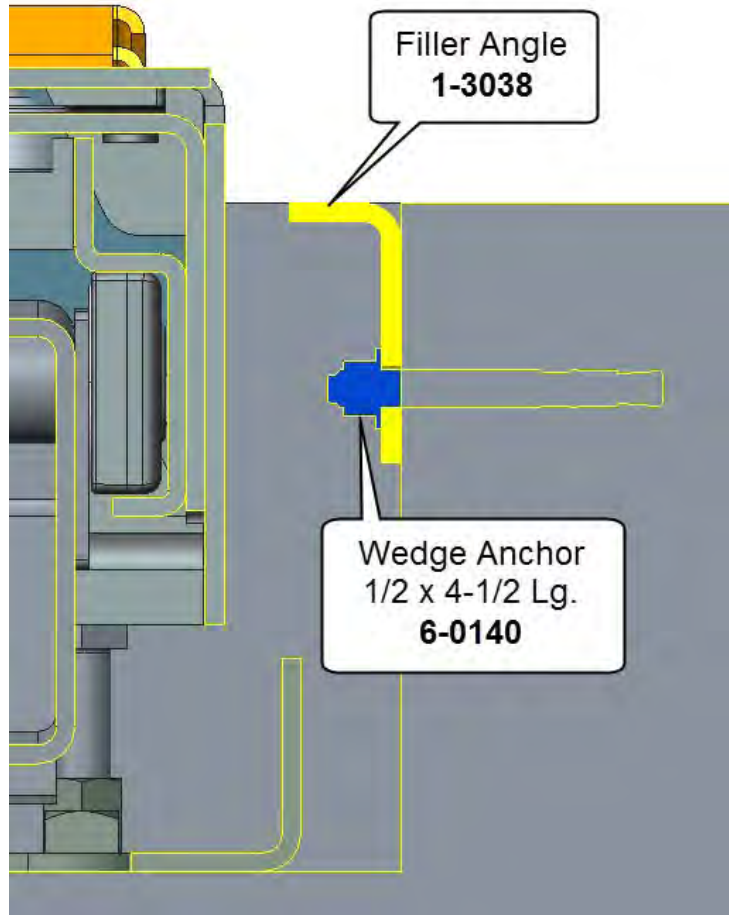

Filler Angle Installation

9.1 Installation of Line Covers

1. Install line covers once console is installed and hydraulic lines are routed.
2. Position line cover "C" behind the right baseframe as shown.
3. Cut 11-3/8" off length of line cover "B" and position it behind the left baseframe as shown. Do not discard the cut piece as it will be used in step 4.

Note: It is important to create square cuts. The use of a sliding miter saw or a simple miter box is recommended.

4. Position the line covers "A" between line cover "C" & "B" and mark where they overlap. Cut each to fit.
5. Using the remaining piece of Line cover "B" from step 2, place as shown below.
6. Position line covers "D" to the console. Cut if required.
7. The number along each side of the line covers represents the quantity of fasteners required to secure them in place. Using a 1/4" concrete drill bit, drill holes as required and install the supplied 1/4" x 1" long nail in anchors (6-0141).

Note: Tapcon or equivalent concrete screws can be used as an option for future removal.

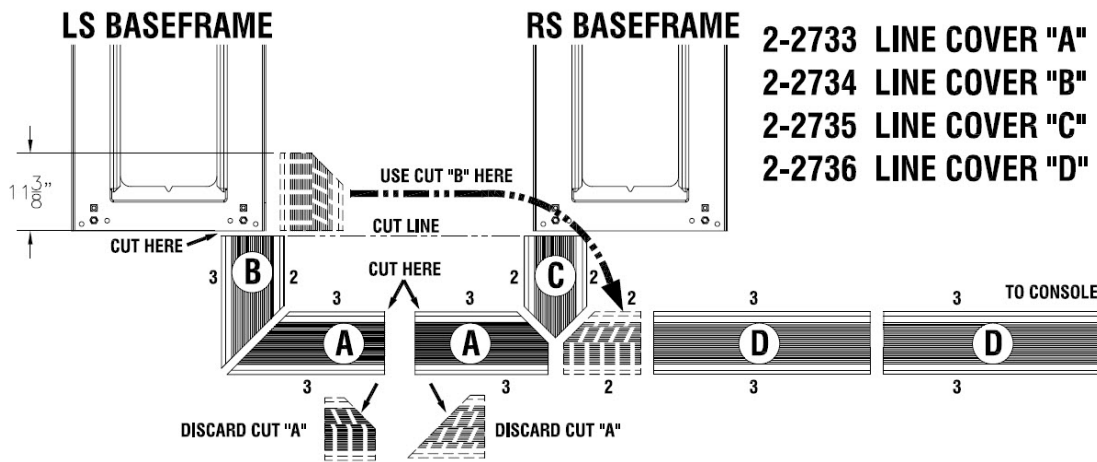

Optional: To locate the consoles on left side of lift, the setup is mirrored with the following changes to the above installation steps:

- Step 3 – use line cover A instead of B.
- Step 4 – use (2) of line cover B.
- Step 5 – use remainder of line cover A from step 3.

Note: If baseframe is shimmed to a point where the line cover does not sit flush due to interference with hoses, the line cover can be heated with a heat gun and then placed over the hoses for a cleaner look.



10.0 LOCKING FRONT TURNPLATES & REAR SLIP PLATES (OPTIONAL)

10.1 Installation of Front Turnplates



Avoid inserting fingers in the front alignment pan cut-out, if position of the turnplate assembly exposes such openings.



Ensure that air supply to the lift is turned off and no person is operating on the console during maintenance of clamping elements of the locking system.



During normal use, the front turnplates and rear slip plates may move rapidly, when locking system is activated. This creates pinch points for your fingers or hands. Keep hands clear of these pinch points when lift air supply is connected. No person shall operate console while maintenance or inspection of the slip plates is in process.

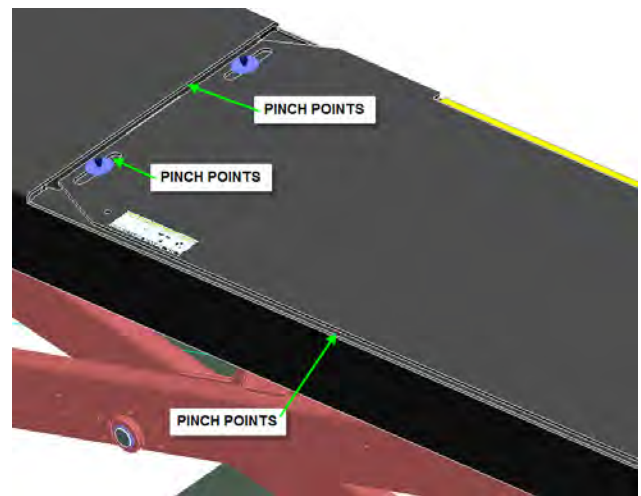
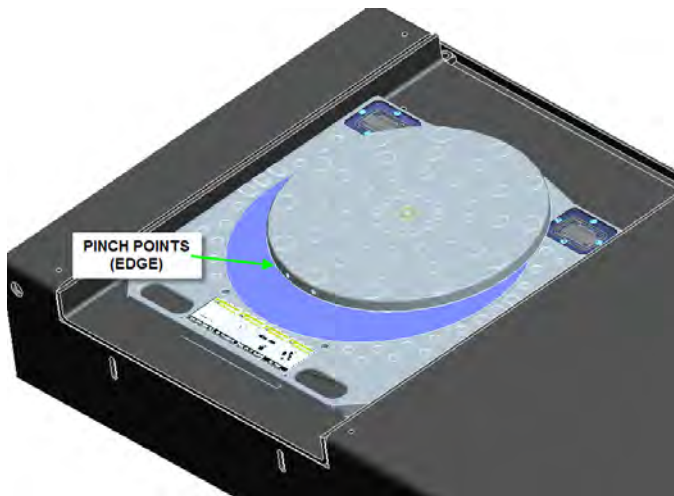

1. Lower lift to a comfort height.
2. Place each front turnplate assembly, one by one, on the front alignment pan on runway. Moving handles of the turnplates should be oriented to the outside of lift, shown below.

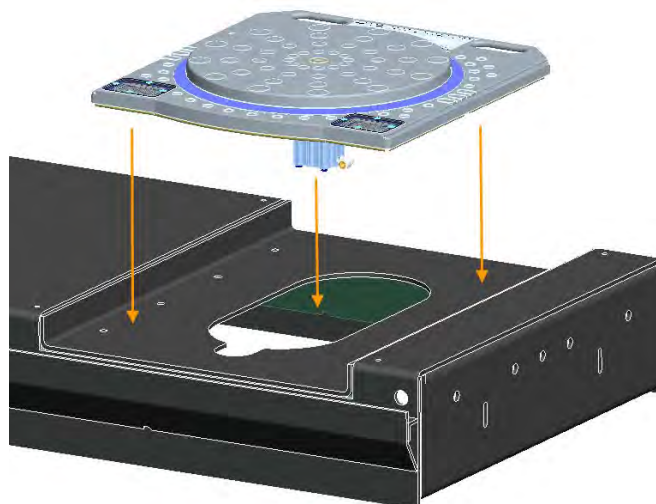

Ensure that the locking system components on the bottom of the turnplate (air cylinder, fittings, and plastic clamping parts) are not hit against the runway during placement.

3. Verify that the turnplate assembly is completely seated in the front alignment pan. Gently slide each turnplate in the alignment pan, left and right, to verify that they can be positioned for different car widths. Do not hit plastic locking ring forcefully against the edges of the cut-out in the front alignment pan.
4. Connect free ends of front air lines to the turnplate locking cylinder: blue air line to the cylinder port marked with a blue dot and red air line to the cylinder port marked with a red dot [Figure shown below].
5. Plug the electrical connector on the turnplate light cord into the electrical connector on the cable at the front.

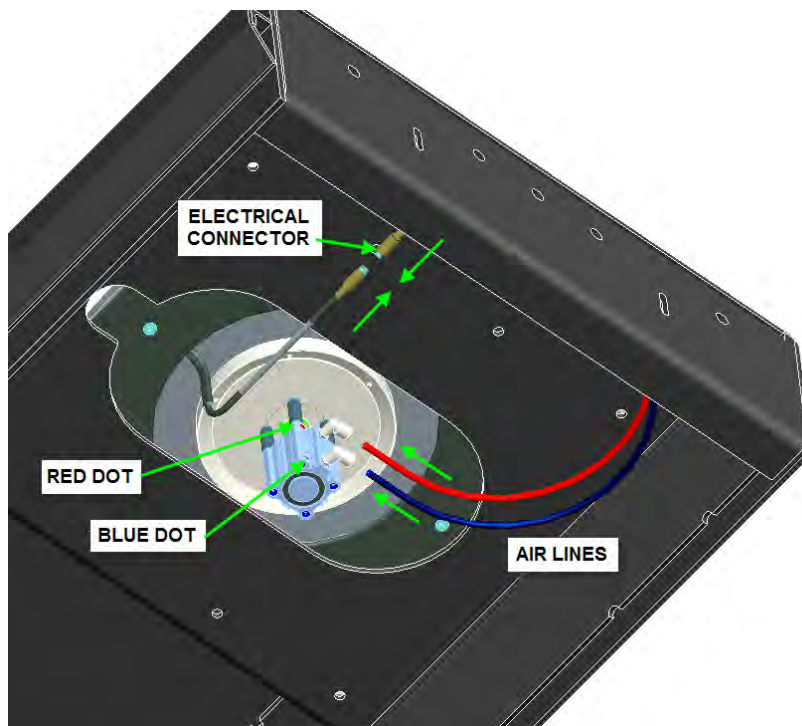

*Note: Objects in pictures may not be exactly as shown.

10.2 Console Connections for Locking & Lights

Locking & Light System

1. Connect the (2) red & blue polytubes from lift to corresponding “y” fitting in the console (see Detail C).
2. Connect the 4mm polytube labeled “Return” to pushlock fitting on the LED driver box. Connect the other 4mm polytube labeled “Supply” to the pushlock “Tee” w/ reducer (see Detail “A”)
3. Connect the red & blue electrical connectors from lift to corresponding red & blue electrical connectors from the LED driver box (see Detail B).

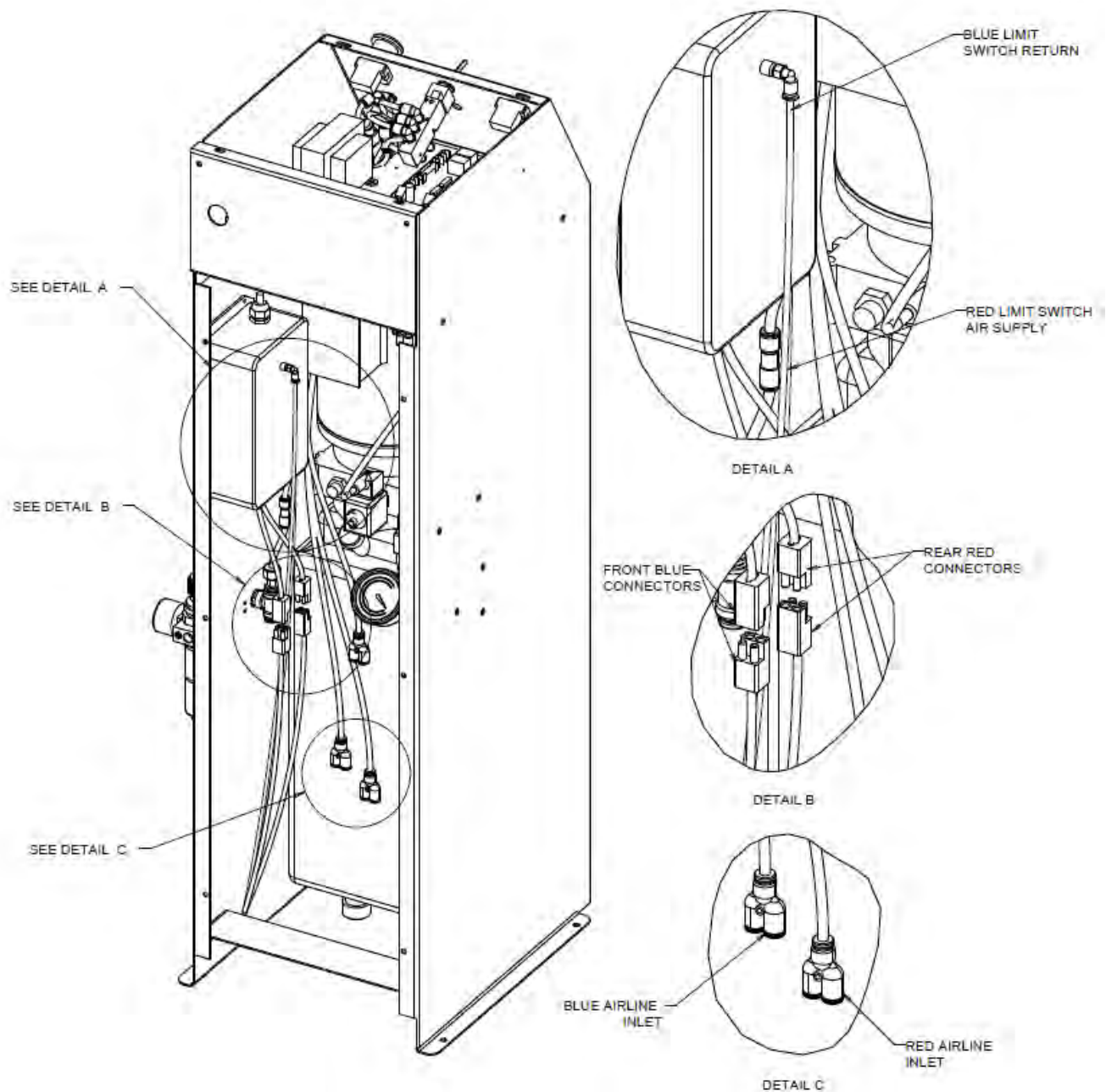

4. Once all connections are made, test system as follows:

- a. **Light System – Lift must be fully collapsed.** Start raising lift. At approximately 30” from the ground, the lights will illuminate. If not, please check that the 4mm polytube connections are correct as they may be reversed.

Comparable to the Upper Limit System (see [Section 7.7](#)), the Light kit is turned on by a similar method. This system will have its own Cam and Sensor, located on the upper hinge at the front right side runway.

NOTE: Unlike the Upper Limit System, this system is not adjustable and is factory set.

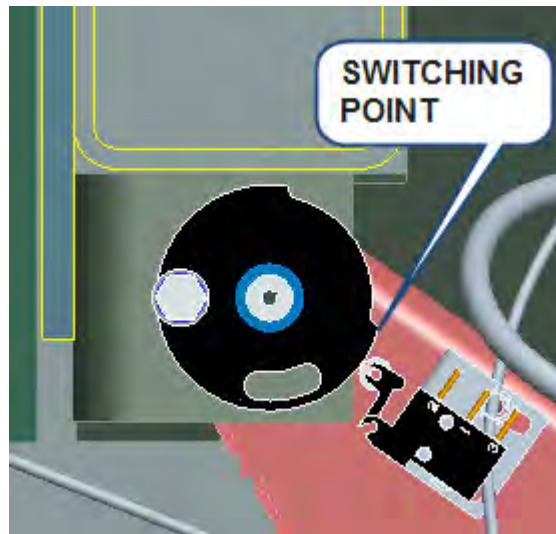

- b. **Locking System** – On front of console, switch the Slip Plate lever to “Unlock”. All locking plates should be free to move, please verify. Now switch the lever to “Lock”, all locking plates should be centered and locked, please verify. If not, check that all polytube connections are correct and there is 90-120 psi of air pressure.

11.0 FINAL PROCEDURES

11.1 Check of Assembled Lift

1. Final dimension check after anchoring. _____
2. Check for air and hydraulic leaks. _____
3. Re-check level of decks, front to rear, side to side. _____
4. Check all fasteners, tighten if necessary. _____
5. Check torque of anchor bolts (Sect. 7.12) _____
6. Operate lift to full stroke then lower to ground while checking for proper functionality. Ensure Safety Release is operational. _____
7. Ensure Customer Care Kit is complete and given to operator. _____
 - a. Operation Manual _____
 - b. ANSI / ALI Lift It Right Manual _____
 - c. ANSI / ALI Safety Tip Card _____
 - d. ANSI / ALI ALIS Safety Requirements for Installation and Service of Automotive Lifts _____
 - e. ANSI / ALI Quick Reference Guide _____
8. Ensure Oil has been added to the Filter / Regulator / Lubricator (Sect. 7.6) _____
9. Upper limit switch and height shut off _____
10. Equalizing switch operation _____
11. Train end user on operation of lift. _____

10.2 Operation Test with Vehicle

1. Lower lift to the ground. (Make sure Green Light is OFF) _____
2. Drive vehicle on to lift. _____
3. Raise the lift, and lower onto 3-4 different locking positions until the full lifting height is reached. Check that all locks are working correctly. _____
4. Lower lift to the ground and drive vehicle off lift. _____

If any problems occur during the final checkout or operation of the lift please contact customer service at 1-800-225-5786

12.0 LIFT OPERATION

12.1 Raising the Lift

1. If the lift is equipped with sliding Jack Beam(s), be sure that the Beam(s) are positioned at the front or mid travel of the lift, fully down, and with the risers removed and stored. Never store Jack Beams at the rear of the lift.
2. Ensure that the lift is fully lowered before attempting to load or unload a vehicle.
3. Ensure that locking pins are in the front turnplates and rear slip plates before driving a vehicle onto the lift.
4. Position the vehicle on the lift ensuring the resulting load on the deck is distributed as evenly as possible. Under no circumstances should a vehicle be lifted if the weight distribution is unbalanced by more than 10% on either side. Maximum wheelbase for this lift is 176”.

ATTENTION: THE VEHICLE IS POSITIONED CORRECTLY WHEN THE DISTANCE FROM THE CENTER OF THE TIRES TO THE INSIDE EDGE OF THE RUNWAYS IS EQUAL ON BOTH RUNWAYS, FOR BOTH THE FRONT AND REAR TIRES.

5. Chock the vehicle using the wheel chocks provided.
6. Check that there are no obstructions above the lift that could damage the lift or vehicles.
7. Raise the lift by pressing the up button on the control console. Raise the lift past the desired working height until both mechanical safeties are heard engaging. Press the down button to lower the lift down onto both of the mechanical safeties
8. Do not raise or lower the lift with the vehicle on the Jack Beam.



WARNING! NEVER WORK UNDER A VEHICLE OR THE LIFT UNLESS IT IS POSITIONED ON BOTH MECHANICAL SAFETIES!

12.2 Lowering the Lift

1. Check that there are no obstructions under the lift or vehicle. Be sure that the sliding Jack Beams are fully lowered and positioned at the front or mid section of the lift.
2. Raise the lift by pressing the up button until both runways are clear of their mechanical safety locks.
3. Press the air safety release button to release the mechanical safeties.
4. While holding the air safety release button, press the down button and lower the lift to the completely collapsed position.
5. Remove wheel chocks and ensure that locking pins are in the front turnplates and rear slip plates before driving a vehicle off the lift.
6. Be certain that the lift is completely lowered before removing the vehicle from the lift.
7. Do not raise or lower the lift with the vehicle on the Jack Beam.



ATTENTION: THE OPERATOR MUST ALWAYS KEEP THEIR ATTENTION ON THE OPERATION OF THE LIFT WHILE RAISING OR LOWERING. IF AN OBSTRUCTION IS SEEN, RELEASE BOTH THE AIR SAFETY RELEASE BUTTON AND THE DOWN BUTTON TO STOP THE LIFT.

13.0 RECOMMENDED MAINTENANCE

The following maintenance schedule is recommended for ensuring the operation of the lift. A record of maintenance performed should be maintained and any items that resulted in additional service should be noted.

Schedule	Maintenance Required
Daily	Check that the upper and lower glide tracks are clean and free of debris. This area should be checked before raising or lowering the lift.
	Inspect the operation of the lift by raising and lowering the lift fully.
	Check for the proper engagement and release of mechanical safety locks. If bolts are removed for maintenance re-apply LOCTITE #242 before re-assembly
	Check hydraulic lines for leaks and fraying. Frayed hoses must be replaced immediately.
Weekly	Check the fluid level in the reservoir with the lift fully lowered. Top up reservoir with ISO 32 (10 weight) hydraulic oil as needed.
	Check Oil Level in Air Line Lubricator and refill if required (See 11.2)
Monthly	Check anchor bolts for tightness. Torque to 40 ft-lbs if needed.
	Inspect the electrical and mechanical operation of all switches.
	Inspect runway stop fasteners monthly.
5 Year	Change the hydraulic fluid every five years. Use only ISO 32 (10 weight) hydraulic oil.

NOTE: FAILURE TO FOLLOW RECOMMENDATION MAY AFFECT WARRANTY OF LIFT

13.1 Checking Oil Level for Air Lubricator

The Air Lubricator is located on the outside of the console to allow for easy monitoring of the oil level. If oil level is low, refill the lubricator bowl using one of the following methods:

Method 1 – Can be done under pressure.

1. Unscrew the lubrication plug assembly
2. Refill the bowl using Snap-On Air Oil #IM6 or equivalent
3. Screw in the lubrication plug assembly
4. Check the number of oil drops again.
This does not usually need to be adjusted

Method 2 – Cannot be done under pressure

1. Release inlet pressure from system
2. Unscrew lubricator bowl
3. Fill the lubricator bowl using Snap-On Air Oil #IM-6
4. Screw in lubricator bowl
5. Slowly pressurize system
6. Check the number of oil drops again.
This does not usually need to be adjusted

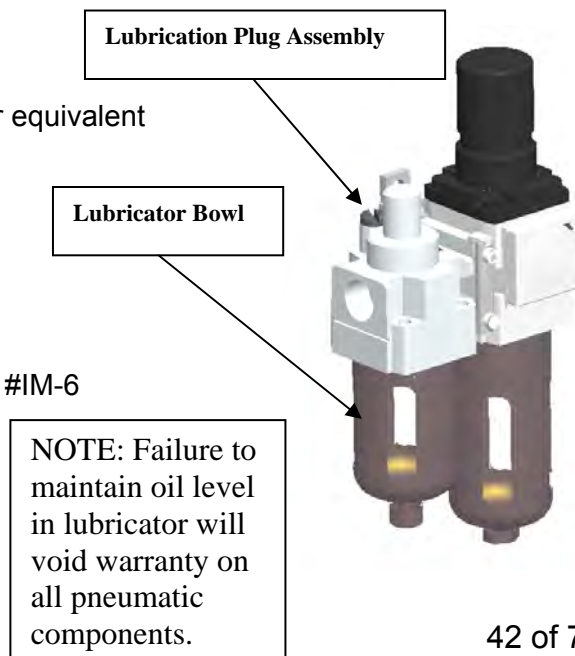

13.2 Maintenance of Turnplate & Slip Plate Locking System (Opt.)

1. Observe locking mechanisms with every lift rise for air line connection integrity. Also ensure that no foreign objects are trapped in the clamping components.
2. Once a week inspect the mating conical surfaces of the front turn table locking mechanism. If necessary, blow with compressed air or wipe with a clean cloth any road dust, salt or other contaminants, including liquids. Greasing of these surfaces is not required and not recommended.

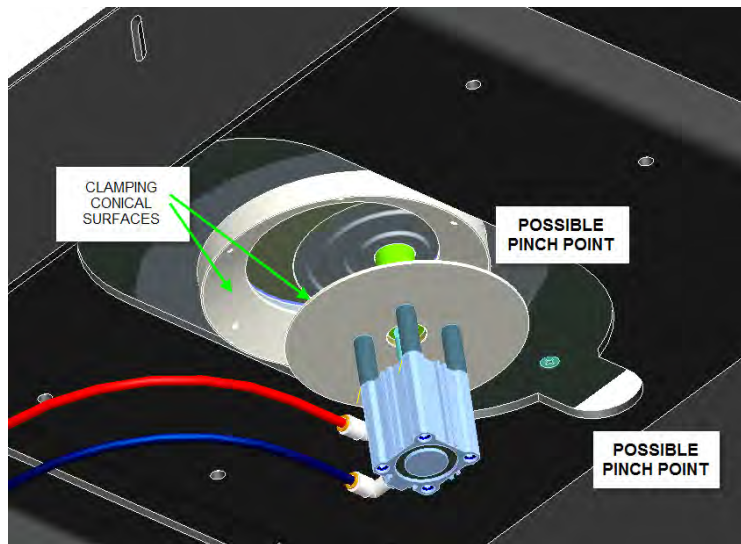

3. After extended use, it may be required that some components of the front turnplate will need replacement, due to normal wear. Please ensure to re-apply *Loctite* where needed, as detailed in the exploded view of the front turnplate – Section 17.1.
4. Once a week inspect locking mechanisms of the rear slip plates. Ensure that clamping jaws are securely attached to cylinder clevises and to pivot pins, and that mounting hardware and air fittings are properly fastened.
5. If replacement of rear clamping components becomes necessary after extended use, re-apply *Loctite* to the threads of the rear cylinder shoulder bolts. Exploded view of one of the 4 rear clamps on the lift is shown in Section 17.2.

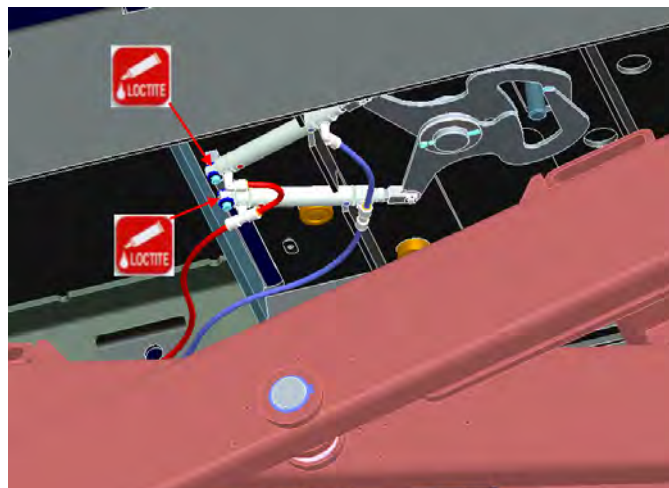

** Re-apply *Loctite* to bolt threads if removing bolts. Tighten shoulder bolts completely in their sockets

11.3 Adjustment of Safety Locks

1. Loosen all the bolts with an 9/16" open wrench

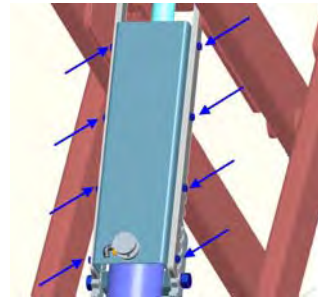

2. Raise lift the lift to its highest position

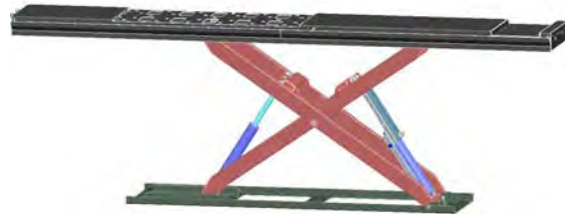

3. Center the top safety rack in between the bottom safety rack.

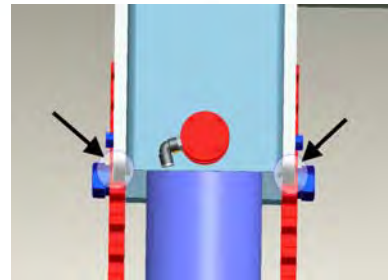

4. Tighten each bolt in sequence as shown in the figure below. Check the alignment after tightening each bolt.

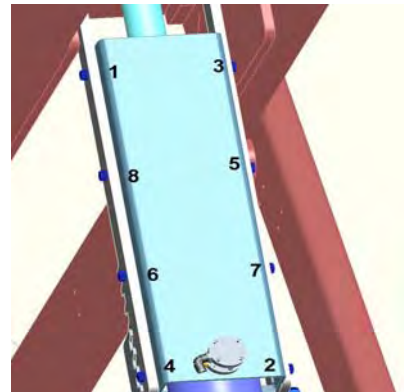

5. Raise the lift and then lower it down, and visually inspect to make sure the adjustment is even. If the adjustment is not even, follow each step again until safety locks touch evenly.

14.0 LOCK OUT AND TAG OUT INSTRUCTIONS

IMPORTANT: This machine does not have integral devices that will isolate the electrical, pneumatic, stored and hydraulic energy source. Appropriate isolation or blocking devices must be used that have the provisions to be switched in the off position and locked in that position.

ALL MAINTANANCE AND SERVICE MUST BE PERFORMED BY A QUALIFIED PERSON.

ALL MAINTANANCE AND SERVICE MUST BE PERFORMED WITH THE LIFT UNLOADED.

IT IS THE SHOP OWNERS RESPONSIBILITY TO ENSURE ENERGY ISOLATING DEVICES ARE:

- **Accessible**
- **Conveniently located to facilitate the application of lockout devices during service and maintenance**
- **Located outside any hazardous area.**
- **At a convenient manipulating height (i.e. not overhead, on ladders or under machinery)**
- **Adequately labeled or marked. Identification shall include machine ID, energy type and magnitude.**
- **Capable of being locked or otherwise secured in an effective isolating position.**

Effective hazardous energy control procedures will protect employees during machine and equipment servicing and maintenance where the unexpected energization, start up or release of stored energy could occur and cause injury, as well as while working on or near exposed de-energized electrical conductors and parts of electrical equipment. Hazards being guard against include being caught in, being crushed by, being struck by, being thrown from, or contacting live electrical circuits/parts.

In preparation for lockout, an initial survey must be made to locate and identify all energy isolating devices to be certain which switch, valve, or other energy isolating devices apply to the machine / equipment to be locked out. More than one energy source (electrical, hydraulic, pneumatic, or others) may be involved.

- SHUT DOWN PROCEDURE:

- Notify all affected employees that a lockout or tagout system is going to be utilized and the reason for. The authorized employee shall know the type and magnitude of energy that the lift utilizes and shall understand the associated hazards.
- **ELECTRICAL:** Located at the user control panel, press the "E-STOP" button to disconnect the raise and lower functions.

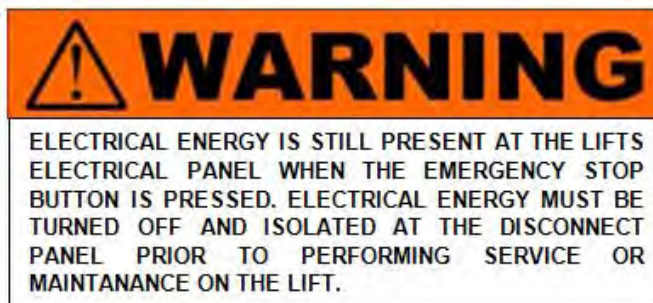

14.1 Isolation and Verification Procedure:

Table 1: ISOLATION AND VERIFICATION PROCEDURES:

ENERGY TYPE AND SOURCE	LOCKOUT LOCATION (TO BE COMPLETED BY END USER)	PROCEDURE FOR LOCING OUT AND OR RELEASING ENERGIES	VERIFY PROCEDURES
<p>STORED ENERGY</p> <p>AND</p> <p>HYDRAULIC PRESSURE 3000-5000 PSI</p>		<p>LOWER THE LIFT TO ITS LOWEST REST POSTION. IF THE LIFT MUST BE SERVICED OR MAINTAINED IN THE RAISED POSITION, ENSURE THAT THE LIFT IS PLACED ON THE MECHANICAL LOCKS AND SUPPORTED BY SUPPLEMENTARY JACK STANDS, BLOCKED AT THE SLIDERS AND A COME ALONG SECURED BETWEEN THE SCISSORS.</p>	<p>VERIFY THAT THE LIFT IS CONTACTING THE SUPPLEMENTARY JACK STANDS, THE BLOCKS ARE SECURLY PLACED AND THE COME ALONG IS SECURED BETWEEN THE SCISSORS.</p> <p>PRESS THE DOWN BUTTON ON THE CONSOLE AND VERIFY THAT THE LIFT DOES NOT LOWER. VERIFY HYDRAULIC PRESSURE HAS BEEN REMOVED BY SLOWLY OPENING THE MAIN HYDRAULIC FITTING AT THE POWER UNIT ONLY. IF FLUID IS PRESENT UNDER PRESSURE, IMMEDIATLY TIGHTEN AND REPEAT LOWER PROCESS. ENSURE THAT BOTH STRUCTURES ARE SECURELY PLACED ON THE STANDS AND BLOCKED.</p>
<p>ELECTRICAL 240VOLTS</p>		<p>AT THE LIFT, PRESS THE EMERGENCY STOP BUTTON COMPLETELY TO DE-ENERGIZE THE CONTROL BUTTONS.</p> <p>AT THE DISCONNECT PANEL, PLACE THE DISCONNECT HANDLE IN OFF POSITION. ATTACH A MULTIPLE LOCKOUT DEVICE. LOCK AND TAG.</p> <p><u>DANGER: LINE SIDE OF DISCONNECT REMAINS ENERGIZED</u></p>	<p>ATEMPT TO RESTART THE SYSTEM, THE SYSTEM MUST NOT START. VISUALLY VERIFY OPEN DISCONNECTS AND LOCKING DEVICE INSTALLED.</p>
<p>PNEUMATIC UPTO 160PSI</p>		<p>SLOWLY CLOSE LOCKOUT VALVE TO RELEASE AIR PRESSURE GRADUALLY. ATTACH MULTIPLE LOCKOUT DEVICE, LOCK AND TAG.</p> <p><u>DANGER: LINE SIDE OF DISCONNECT REMAINS PRESSURIZED</u></p>	<p>VERIFY THE VALVE IS CLOSED AND LOCKOUT DEVICE IS PROPERLY ATTACHED. OPERATE THE PNEUMATIC SYSTEM TO ENSURE THE SYSTEM IS DE-ENERGIZED. IT MAY BE NECESSARY TO BLEED THE SYSTEM OF REMAINING COMPRESSED AIR, THIS CAN BE PERFORMED AT THE BASE OF THE WATER SEPARATOR BOWL.</p>

- RETURNING TO SERVICE:

- Check the lift and the immediate area around the lift to ensure that nonessential items,, tools and parts are removed and that the lift components are operationally intact.
- Check the work area to ensure that all employees have been safely positioned or removed from the work area.
- Notify all employees that the lockout/tagout is going to be removed and the lift is going to restarted.
- Remove the lockout/tagouts in the reverse order as the installation.
- Verify the proper operation of the equipment.
- Notify affected employees that the maintenance/service is completed and the machine is ready for operation.

14.2 Emergency Operation

If the lift becomes inoperative in the raised position, it is best to wait until the electrical power is restored before lowering the vehicle. However, if it's critical to safety that the lift be lowered, the following steps should be taken.



WARNING: DO NOT LOOSEN OR REMOVE HYDRAULIC CONNECTIONS OR FITTINGS UNDER PRESSURE. SERIOUS INJURY OR DEATH COULD OCCUR.

NOTE: Safely performing this process requires 3 people. All personnel should stay clear of the path of the lift. All tools and other non-secured items should be removed from the surface of the runways.

- 1) Survey the area surrounding the lift; remove any items and personnel from area before proceeding with this procedure.
- 2) Perform the appropriate lockout/tag out procedure on the electrical energy.
- 3) Add additional chocks to the vehicle to secure it from movement in the forward and rear direction.
- 4) Use a second person standing at a safe distance away from the lift to keep watch on the area, lift, vehicle and other personnel throughout the process. This person should signal the person performing the procedure to stop if necessary.
- 5) Use a caution tape or similar to barrier the area around the lift to avoid personnel from accidentally entering the area while this process is being performed.
- 6) Do not proceed with this procedure if you are unfamiliar with the lift or its function.

IF THE MECHANICAL LOCKS ARE NOT ENGAGED:

- 1) **If there is air pressure in the pneumatic system;** have another person press and hold the mechanical safety release button to disengage the mechanical locks. Confirm that both mechanical locks have been disengaged and will allow the lift to lower.
If there is no air pressure in the pneumatic system; use a rag to raise the upper mechanical locks to sufficiently clear the lower locks on both sides.
- 2) Remove the 6 screws retaining the rear cover of the control console.
- 3) Locate the flow divider and remove the red caps on the two outer descent valves.
- 4) Slowly turn each manual override thumbscrew in the counterclockwise direction. The lift should not come down at this point.

- 5) Locate the descent valve on the hydraulic power unit, see Figure 21.

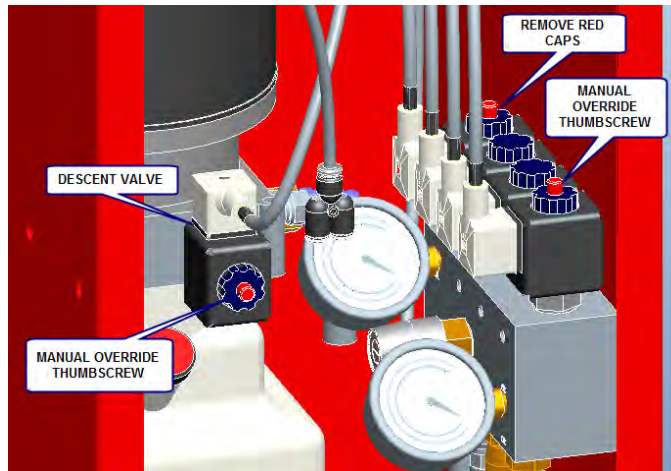

Figure 21 – Image of descent valves

- 6) Locate the manual override thumbscrew (red) on the top of the descent valve, see Figure 30.
- 7) Verbally indicate to all those involved that the lift will now be lowered.
- 8) Slowly turn the manual override thumbscrew in the counterclockwise direction until the lift starts to move.
- 9) Keep a close eye on the movement of the lift and the position of the vehicle; turn the manual override thumbscrew clockwise if any abnormal movement is detected.
- 10) Once the lift is fully lowered, turn the override thumbscrew in the clockwise direction until tight.
- 11) If a rag was used to bypass the mechanical locks, ensure that the rag is removed after the lift has been put back into operation.
- 12) Once power is restored follow the lockout/tag out procedure to return the lift back into service.

IF THE MECHANICAL LOCKS ARE ENGAGED:

Various methods can be used to raise the lift in order to get sufficient clearance to disengage the mechanical locks. The safest method would employ temporary electrical power to the lift using a portable power generator. Any electrical connections should be done by a licensed electrician; lock out/tag out procedures should also be employed at this time.

This process should only be performed by a trained professional. Contact customer service or a local service professional for further assistance.

15.0 TROUBLE SHOOTING

PROBLEM	REASON	SOLUTION
Motor does no turn.	Bad fuse or circuit breaker.	Re place fuse or reset breaker.
	Incorrect voltage to motor.	Provide proper voltage to motor.
	Incorrect wiring.	Have certified electrician check
	Motor switch is malfunctioning	Replace motor switch.
	Motor burned out	Re place motor.
Motor runs but lift doesn't go up .	L ow oil level	Fill reservoir with proper hydraulic oil.
	Wrong rotation	Check for oil flow & reverse electrical leads
Lift doesn't come down.	Dirt in hydraulic lines	*Secure vehicle on lift and refer to section 14.0 Lock Out and Tag Out Instruction. Contact customer service.
	Check power to hydraulic lines	
	No power to solenoids	Check power to solenoids
Safety doesn't disengage .	Lift not raised high enough for disengagement	Press Up button for longer period of time .
	Air not supplied to air cylinder	Check if supply line has air.
	Air cylinder malfunctioning	Replace air cylinder.
Lift goes up un-level.	Flow-divider defective	Reverse hydraulic connections
	Blockage in hydraulic hose	Remove & inspect flow through line
Anchor Bolts do not stay tight	Holes are to large.	Relocate lift using proper drill Size.
	Incorrect concrete floor specification. (Thickness and Strength)	Concrete should be replaced by an appropriate concrete pad . (Consult Product Manufacturer / Supplier for further details)

16.0 RECORD OF MAINTENANCE / TRAINING

Records of all lift maintenance and operator training should be recorded in the following table.

MAINTENANCE & TRAINING PERFORMED	DATE	BY:	NOTES

17.0 LIFT ASSEMBLY

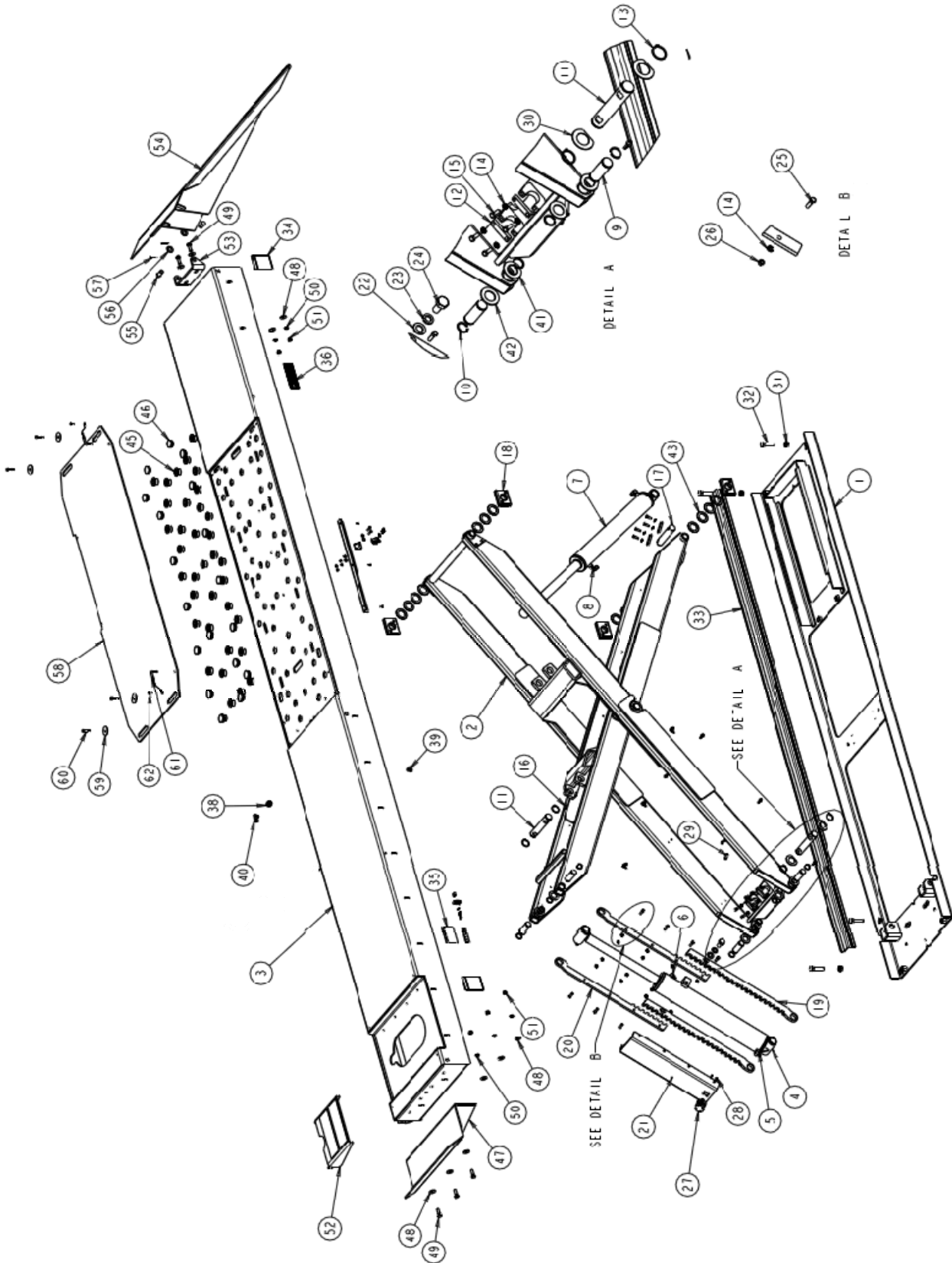

REPLACE WORN, DAMAGED OR BROKEN PARTS WITH PARTS APPROVED BY THE ORIGINAL EQUIPMENT MANUFACTURER ONLY

17.1 Lift Assembly Parts List

Item#	Part #	Description	Qty.
1	3-1134	BASEFRAME WELDMENT	1
2	4-1385	WELDMENT, SCISSOR	1
3	4-1442	DECK WELDMENT, LS	1
4	3-0896	CYLINDER ASSEMBLY, PRIMARY	1
5	6-2956	VELOCITY FUSE	1
6	6-3008	90 HYD ELBOW FORGD 3/8 NPT - 3/8 JIC (FUSE)	2
7	3-0897	CYL ASSEMBLY, SEC	1
8	6-3058	ELBOW, 3/8 NPT M TO 3/8 POLY F	1
9	1-2788	HINGE PIN	4
10	6-0340	CIRCLIP TRU-ARC #5100-125	8
11	1-2789	PRIMARY CYLINDER PIN	2
12	1-2793	CYLINDER RETAINER	4
13	6-0233	SNAP RING, #5100-150	4
14	6-0058	LOCK WASHER, 3/8"	16
15	6-0067	HEX BOLT, 3/8" NC X 1" LG	8
16	6-3061	SET SCREW 3/8" DIA. - 1" LG	4
17	1-2790	CYLINDER PIN, SECONDARY	2
18	2-2725	GLIDE BLOCK	4
19	2-2111	SAFETY BAR BOTTOM	2
20	2-2112	SAFETY BAR, TOP (LASER CUT)	2
21	2-3020	SAFETY COVER WELDMENT	1
22	6-0738	FLAT WASHER 3/8" SAE	2
23	6-0259	LOCK WASHER, 3/4	2
24	6-2936	HHCS, 3/4-16 UNF X 1-1/2 LG	2
25	6-0666	HEX BOLT 3/8 UNC X 1-1/4 LG, GR8	8
26	6-0034	HEX NUT, 3/8" NC	8
27	1-4098	SAFETY CYLINDER ASSY.	1
28	6-4248	BHCS, M6 X 20MM LG.	4
29	6-4247	ROD END	1
30	1-2905	SAFETY LOCKS	2
31	80259000	HEX JAM NUT, 3/4"-NF	4
32	6-3569	BOLT	4
33	2-2707	BASEFRAME LINE COVER	1
34	KY089004	WARNING DECAL	2
35	6-1763	CAPACITY DECAL, 12K OR 14K LB	1
36	1-3719	LABEL, TT, LOCKING	1
37	6-3915	DECAL, PATENTS PENDING	1
38	6-0713	TERMINAL BOLT, 3/4", SHORT	1
39	6-3010	90 DEG. ELBOW, PNEU. 1/4" NPT M - 3/8" F, PUSH	1
40	6-3896	PNEUMATIC TEE FITTING	1
41	1-3255	HINGE SPACER 1/16" THK	4
42	1-3256	HINGE SPACER 1/8" THK	2
43	1-3171	THRUST WASHER	15
44	6-3998	TREE MOUNT CABLE TIE, 8' LG.	12
45	6-3974	BALL TRANSFER	36
46	1-3762	PLASTIC INSERT	18
47	2-2117	WHFFI STOP WELDMENT	1
48	6-0063	FLAT WASHER, 1/2"	10
49	6-0291	Hex Bolt, 1/2"-13UNC X 1 1/2 LG.	5

50	6-0059	Lock Washer, 1/2"	5
51	6-0035	NUT, 1/2-13 UNC, HEX	5
52	2-211904	WORKSTEP	1
53	1-3159	ADAPTOR PLATE	1
54	3-0905	APPROACH RAMP ASSEMBLY	1
55	1-1887	HEADED PIN	2
56	6-0738	FLAT WASHER 3/4" SAE	2
57	6-0978	Cotter Pin, 1/8 DIA. X 1 1/2 LG.	2
58	2-2088	REAR SLIP PLATE	1
59	6-0426	FLAT WASHER	4
60	6-0069	SHOULDER BOLT, 3/8" DIA. X 5/8" LG.	4
61	2-0637	LOCKING PIN ASSEMBLY	2
62	6-2565	BHCS, 1/4-20 UNC X 3/4 LG	2

Additional/Optional Parts:

Item #	Part #	Description	Qty
3	4-1443	Deck Weldment RS	1
	4-1445	Deck Weldment RS (Locking & Lights Option)	1
	4-1444	Deck Weldment LS (Locking & Lights Option)	1
54	3-0905	Approach Ramp Assembly (Surface Mount)	2
	3-0698	Approach Ramp Assembly (Flush Mount)	2
58	2-2088	Rear Slip Plate	2
	2-2721	Rear Slip Plate Weldment - LS (Locking & Light Option)	1
	2-2740	Rear Slip Plate Weldment - RS (Locking & Light Option)	1
*	0-1506	Hinge Spacer Kit - 1/8" & 1/16" (16/PKG)	1
**	0-1669	Seal Kit, Primary Cylinder 3-0896	1
***	0-1670	Seal Kit, Secondary Cylinder 3-0897	1

ITEM #27: 1-4098 Air Cylinder Assembly

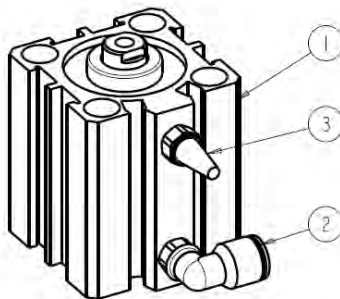

1	1-4098	Air Cylinder (Complete w/ Fittings)	1
2	6-4255	90 Deg. Fitting 6mm (1/4") Poly - M5x0.8	1
3	6-4256	Breather Vent / Exhaust Muffler	1

18.0 REAR SLIP PLATE TRANSFER BALL ARRANGEMENT

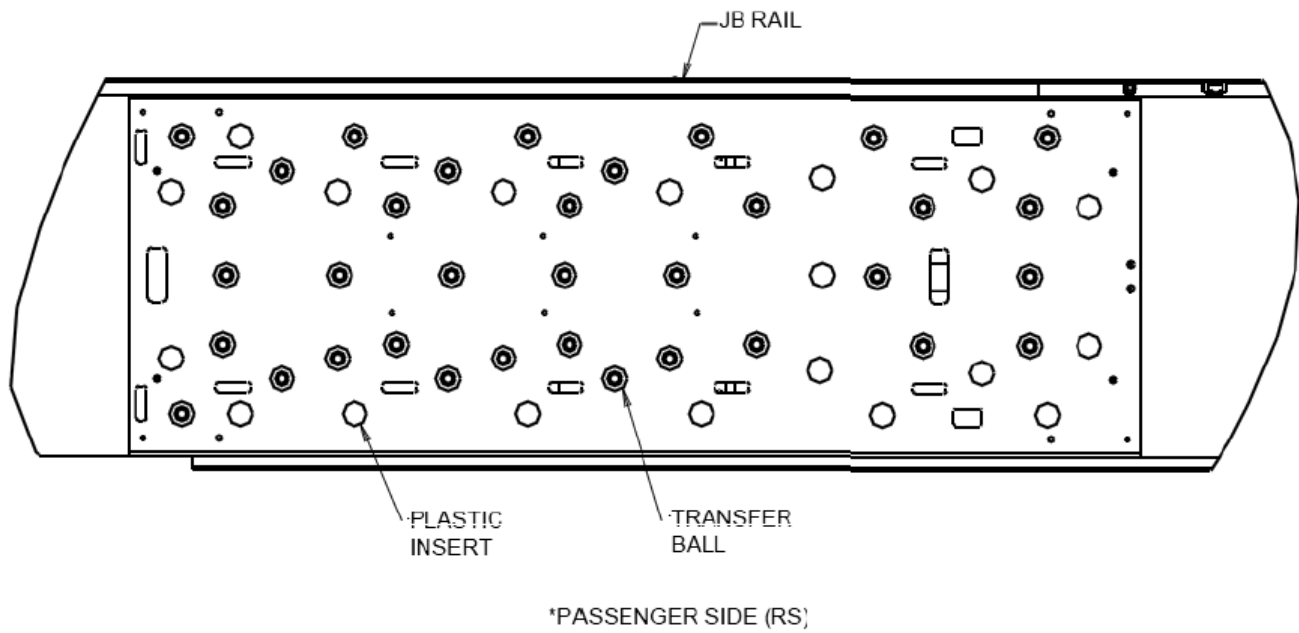
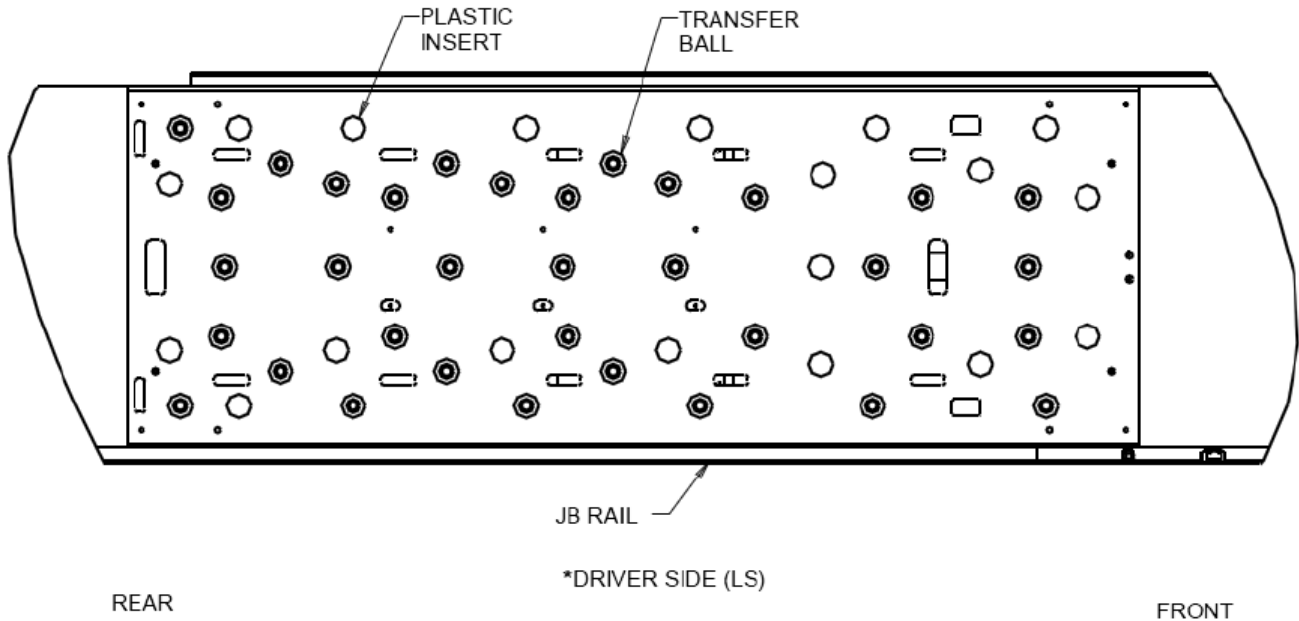

Item #	Part #	Description	Qty. / Deck
1	1-3762	Plastic Insert	19
2	6-3974	Transfer Ball	35

19.0 HYDRAULIC & AIR ASSEMBLY

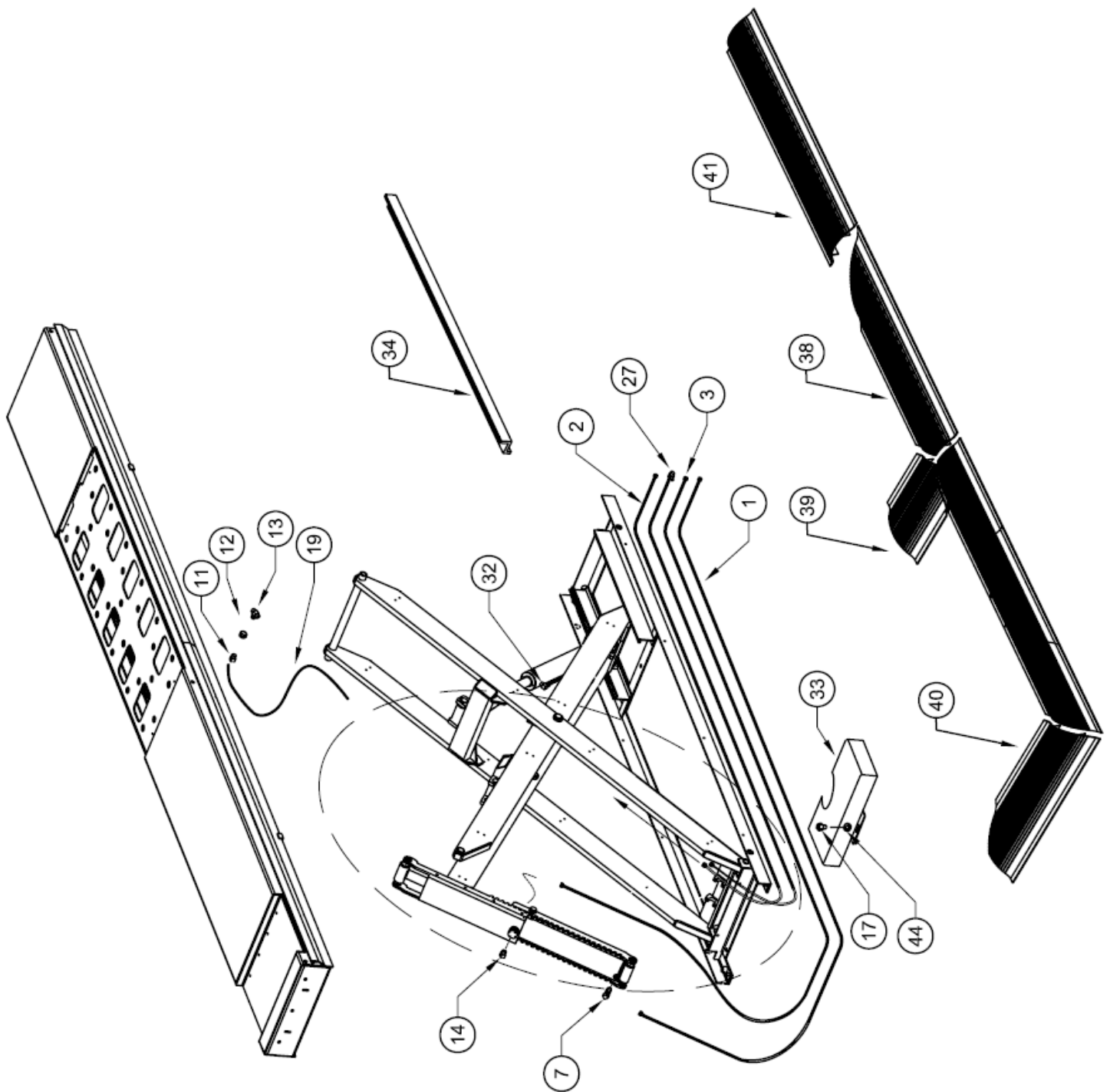

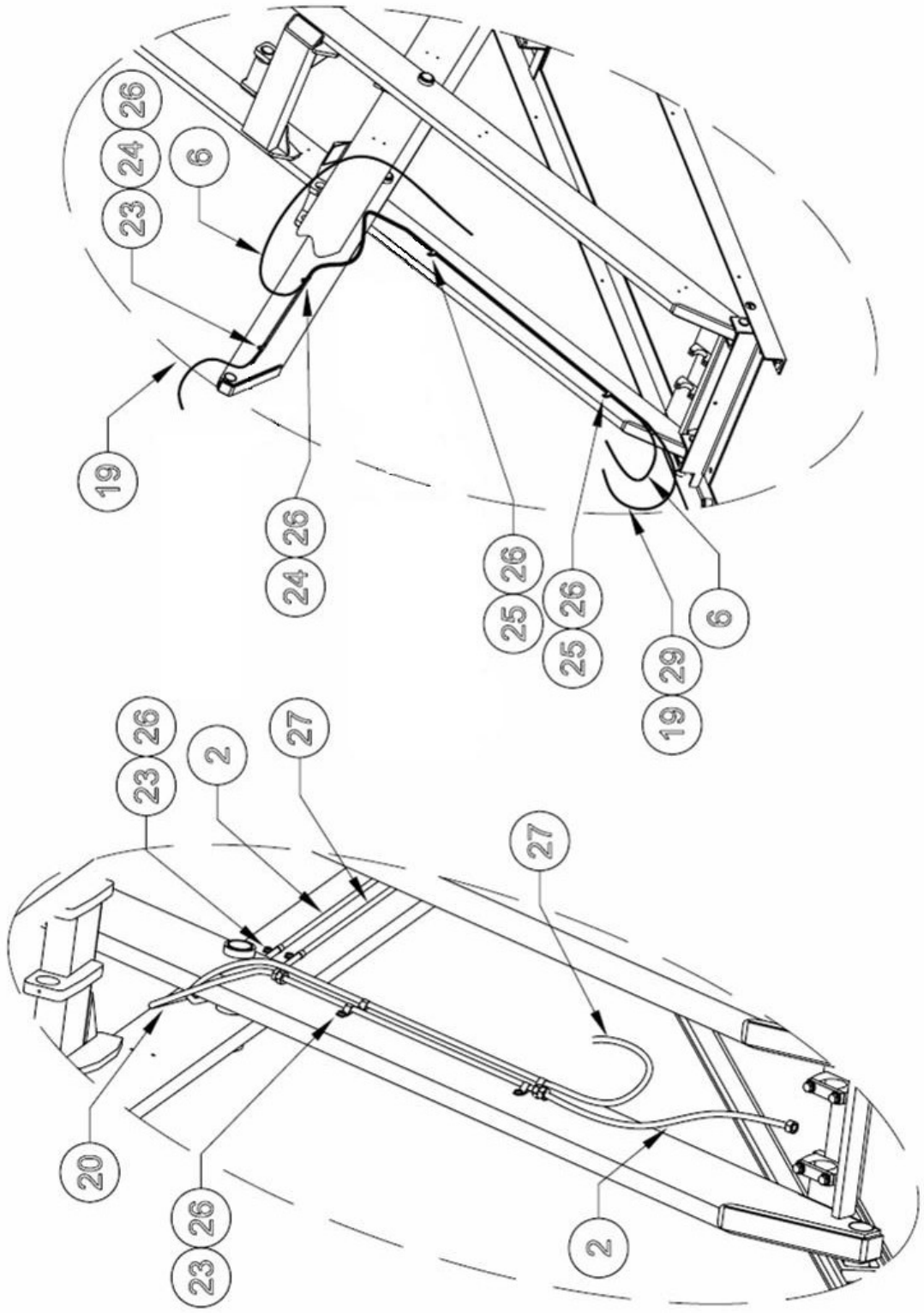

19.1 Line Routing Parts List

1	2	3/8" HYDRAULIC HOSE – CYLINDER (LS/RS)	2-2143
2	1	3/8" HYDRAULIC HOSE – LS	2-2718
	1	3/8" HYDRAULIC HOSE – RS	2-2719
3	2	3/8" HYDRAULIC HOSE – EQUALIZE (LS/RS)	2-2717
6	1	1/4" POLYTUBE SAFETY AIR LINE	6-3020
7	2	VELOCITY FUSE	6-2956
10	2	90 DEG ELBOW, 3/8" JIC-M, 3/8' JIC-F	6-0813
11	1	90 DEG ELBOW, 1/4" NPT-M, 3/8" POLYTUBE	6-3010
12	1	TERMINAL BOLT, 3/4"	6-0713
13	1	BRANCH TEE FITTING, 1/4" NPT, F-F-M	6-3896
14	2	90 DEG ELBOW, 1/8" NPT, 1/4" POLYTUBE	6-0709
15	1	TEE FITTING, 1/4" POLYTUBE	6-2971
16	2	FRONT COVER	2-2185
17	6	HEX BOLT, 1/4" NC x 3/4" LG	6-0178
18	2	LOCKWASHER, 1/4"	6-0056
19	1	3/8" POLYTUBE SUPPLY AIRLINE	6-3019
23	6	PIPE CLAMP, 3/8"	6-0170
24	14	PIPE CLAMP, 1/2"	6-0536
25	6	PIPE CLAMP, 5/8"	6-1547
26	24	SELF THREADING SCREW	6-1134
27	2	POLYTUBE RETURN LINE 3/8"	6-3082
32	2	90 DEG ELBOW, 3/8" NPT-M, 3/8" POLYTUBE	6-3058
33	2	FRONT COVER	2-2803
34	2	BASEFRAME LINE COVER LH	2-2299
37	2	HEX SOCKET CAP SCREW #10-24 UNCx 1"LG	6-3096
38	2	FLOOR LINE COVER "B"	2-2734
39	2	FLOOR LINE COVER "C"	2-2735
40	2	FLOOR LINE COVER "A"	2-2733
41	2	FLOOR LINE COVER "D"	2-2736
42	1	BASEFRAME LINE COVER RH	2-2301
44	3	WASHER FLAT 1/4 SAE	6-0060
47	2	NAIL-IN ANCHORS, 1/4" X 1" LG	6-0141

20.0 HEIGHT LIMIT ASSEMBLY

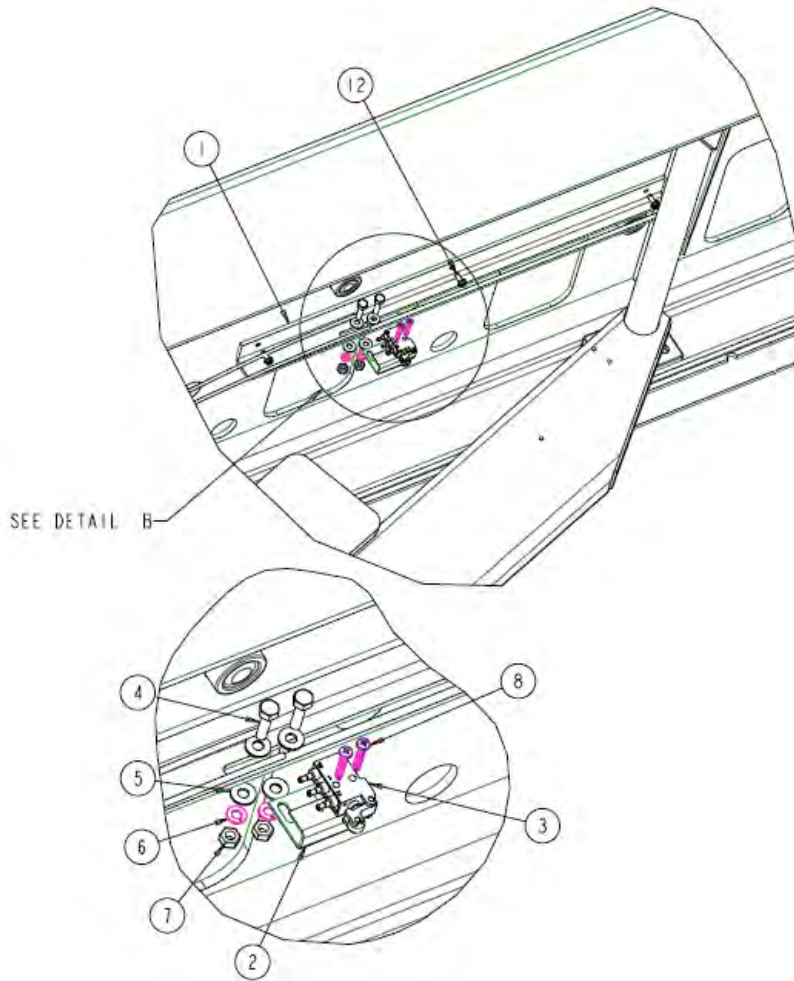

Note: Height Limit Sensor is located under Rear of Driver Side Deck.

20.1 HEIGHT LIMIT / LEVELING PARTS LIST

Item #	Part #	Description	Qty.
1	1-3770	Sensor Track	1
2	1-3771	Sensor Bracket	1
3	6-3964	Limit Switch w/ Roller Lever	1
4	6-0008	Hex Head bolt, 1/4"-20UNC x 1" Lg.	2
5	6-0060	Flat Washer, 1/4"	4
6	6-0056	Lock Washer, 1/4"	2
7	6-0032	Nut, 1/4"-20UNC	2
8	6-3965	Pan Hd Machine Screw, 8-32 x 1"lg	2
12	6-1134	Threat Cutting Screw, #12 x 1/2"lg	3

20.2 EQUALIZE SENSORS PARTS LIST

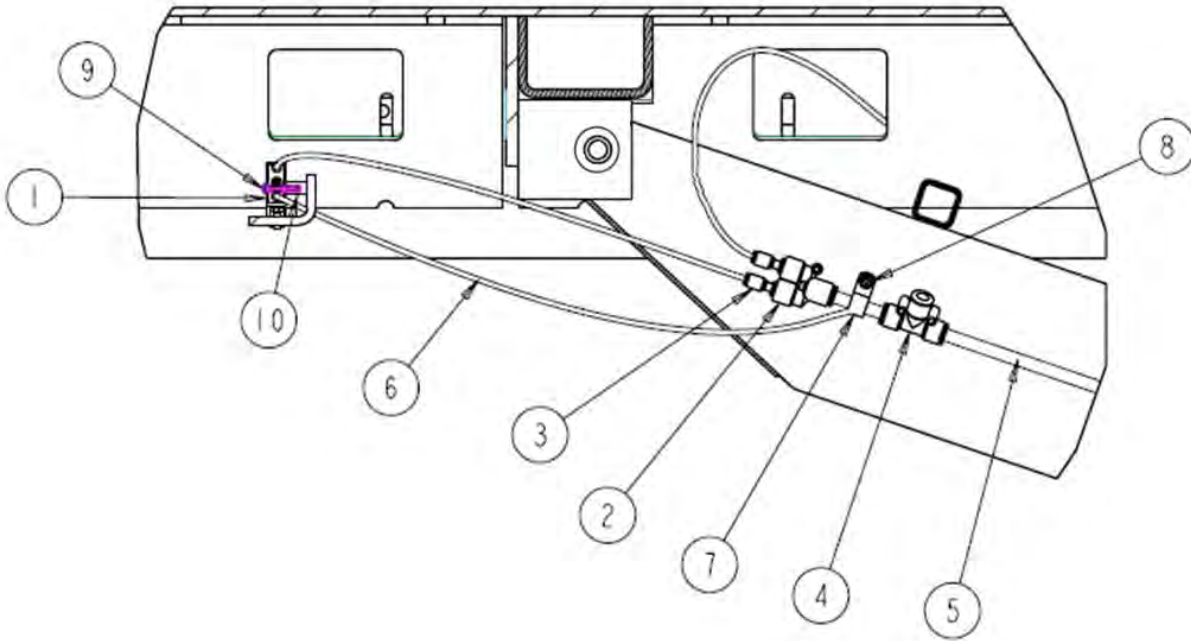

Note: Equalizing Sensors are located under Front of Driver & Passenger Side Deck.

20.3 HEIGHT LIMIT / LEVELING PARTS LIST

Item #	Part #	Description	Qty.
1	6-3964	Limit Switch w/ Roller Lever	1
2	6-3943	Branch Y, 3/8" – 1/4"	1
3	6-3928	Reducer, 1/4" – 5/32"	2
4	6-3011	Tee fitting, 3/8"	1
5	6-3019	3/8" Polytube Supply Airline	1
6	8-0378	4mm Polytube Blue (ft)	53
	8-0377	4mm Polytube Red (ft)	125
7	6-0536	Clamp, 1/2"	2
8	6-1134	Thread Cutting Screw, #12 x 1/2" Lg.	2
9	6-3987	Machine Screw, #8 x 1-1/2" lg.	2
10	1-3777	Plastic spacer	2

20.4 OPTIONAL: LIGHT KIT SENSOR PARTS LIST

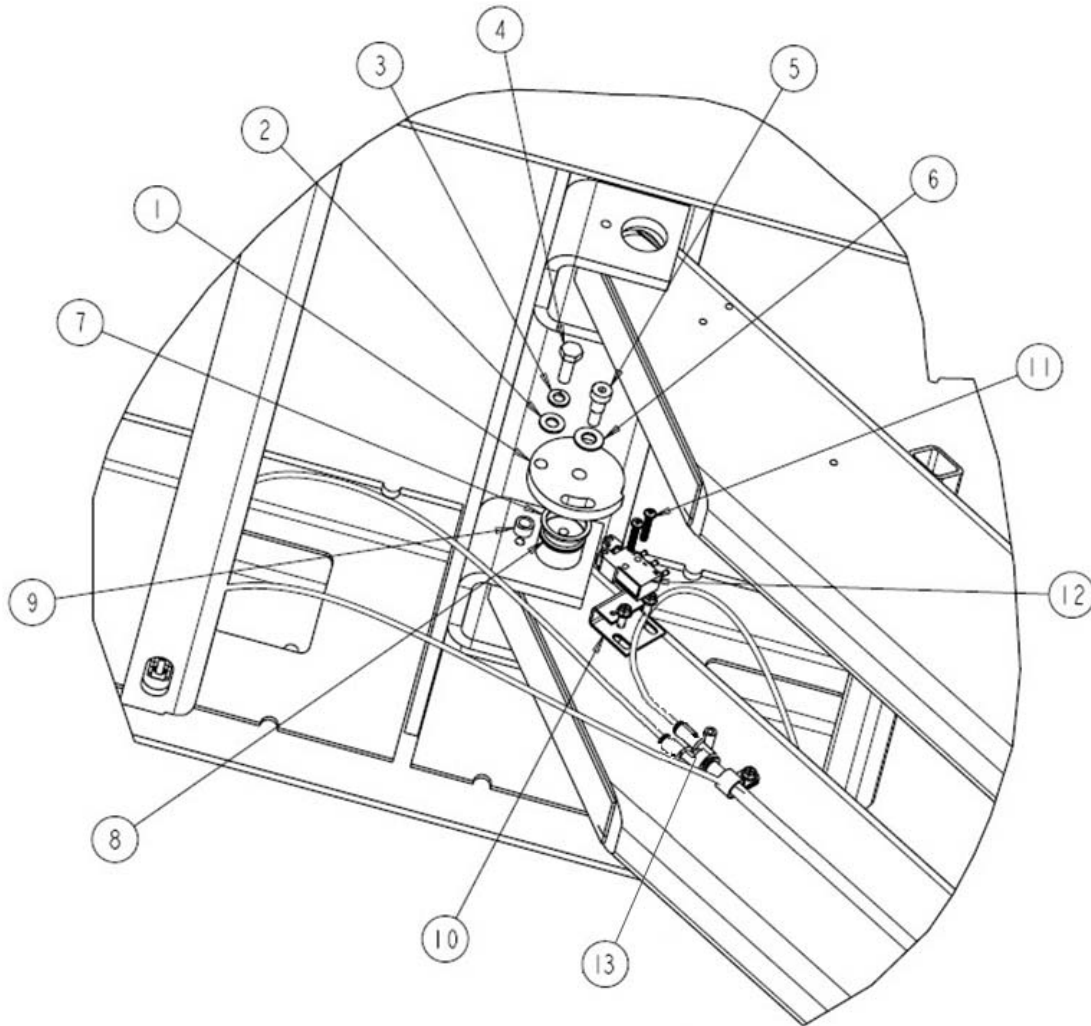

Item #	Part #	Description	Qty.
1	2-2757	Plastic Cam	1
2	6-0295	Flat Washer, 5/16"	1
3	6-0674	Lock Washer, 5/16"	1
4	6-0293	Hex Head bolt, 5/16"-18UNC x 1" Lg.	1
5	6-1792	Shoulder Bolt, 3/8" x 1/2" Lg.	1
6	6-0062	Flat Washer, 3/8"	1
7	6-0340	Circlip	2
8	1-3754	Hinge Pin, Cam	1
9	1-3752	Spacer	1
10	1-3771	Sensor Bracket	1
11	6-3965	Machine screw, #8-32 x 1"lg	2
12	6-3964	Limit Switch w/ Roller Lever	1
13	6-3944	Union, 'Y', 5/32" (4mm) Polytube	1
*	8-0378	4mm Polytube Blue	40 ft
*	8-0377	4mm Polytube Red	40 ft

Note: Light Kit Sensor Assembly is located under Passenger Side Deck.

21.0 ACCESSORY ASSEMBLY

21.1 Front Turnplate

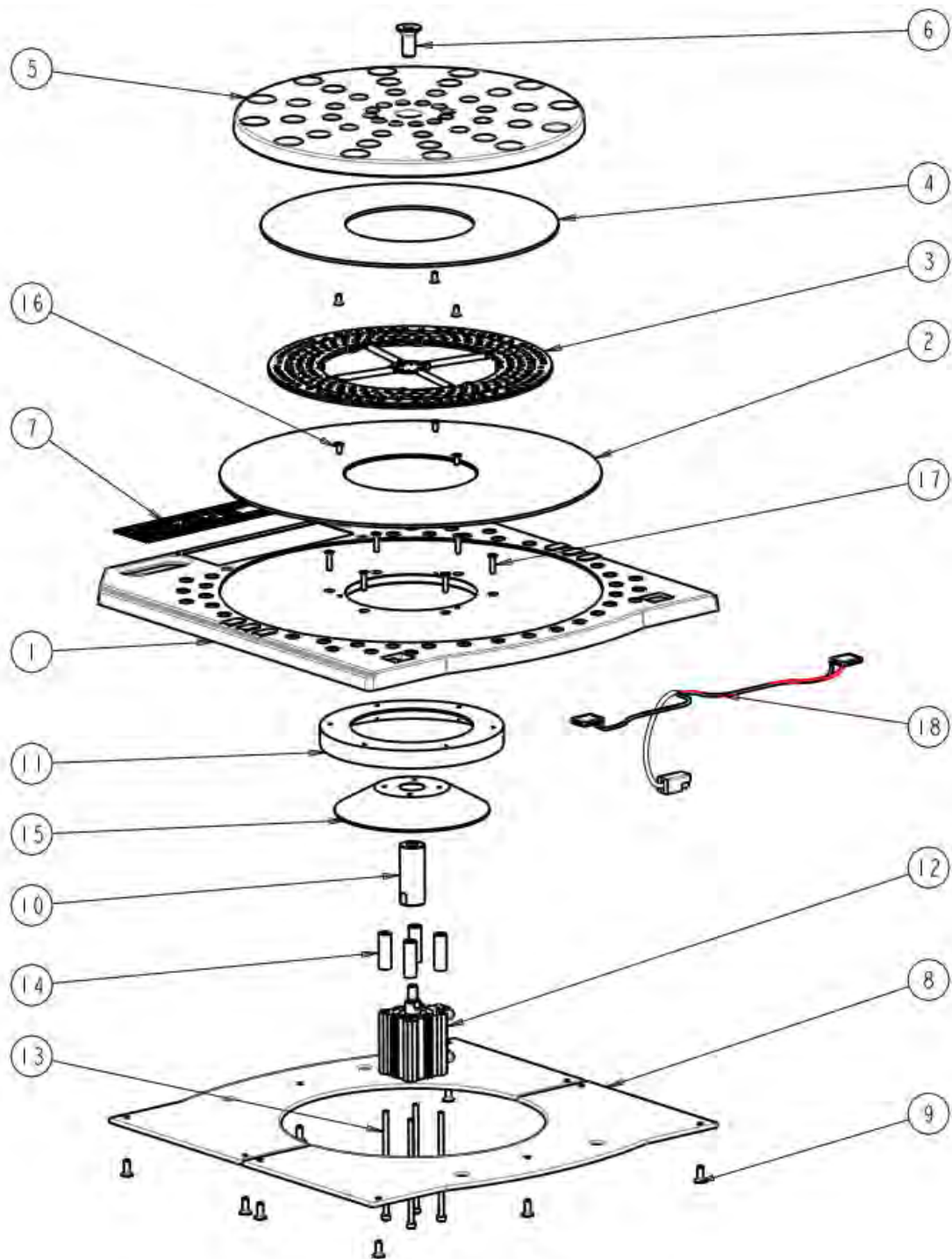

TURNPLATE ASSEMBLY: PARTS LIST

Item #	Part #	Description	Qty.
1	2-2932	Turnplate Assembly (Complete)	1
2	EAM0047J58A	Bottom Wear Plate	1
4	EAM0047J57A	Wear Plate, Top	1
5	EAM0047J60A	Turnplate Top	1
7	1-3719	Label	1
8	EAM0047J52A	Wear Pad, Bottom	2
9	6-3955	FHMS, Phil Screw - M6 x 16mm	10
10	1-3678	Stub Shaft	1
11	2-2711	Centering Ring	1
12	6-3899	Locking Cylinder Assembly	1
13	6-3903	FHCS, #8-32 UNC x $\frac{3}{4}$ ", SS	8
14	1-3677	Cylinder Stand-off	4
15	2-2709	Centering Cone	1
16	6-3954	Screw, FHMS M5-8 x 10mm Lg	6
17	6-3904	FHCS, #10-32 UNF x $\frac{3}{4}$ ", SS	6
18	6-4101	LED Light & Cable Assembly	1

Note: Please contact customer service for items not listed.

21.2 Rear Slip Plate Locking Mechanism

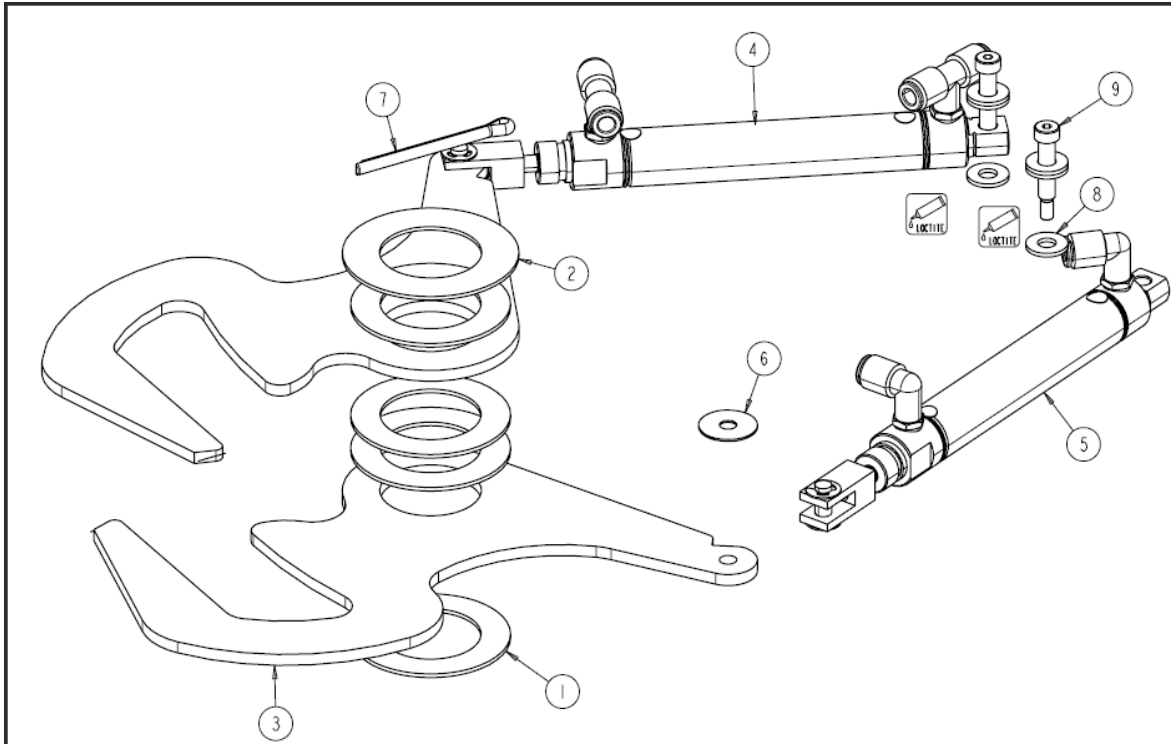

Item #	Part #	Description	Qty.
1	1-0757	Nylon Thrust Washer	4
2	1-3686	Spacer	1
3	2-2712	Retainer Jaw	2
4	6-3900	Cylinder Assembly	1
5	6-3883	Cylinder Assembly	1
6	6-3882	Washer, Nylon 1/4" ID 5/8" OD	2
7	6-3929	Cotter Pin, 3/16" x 2" lg, SS	1
8	6-0060	Flat Washer, 1/4" ID	6
9	6-3907	Shoulder Bolt, 1/4" x 5/8" lg. SS	2

21.3 Airline Routing for Locking Turnplates and Rear Slip Plates

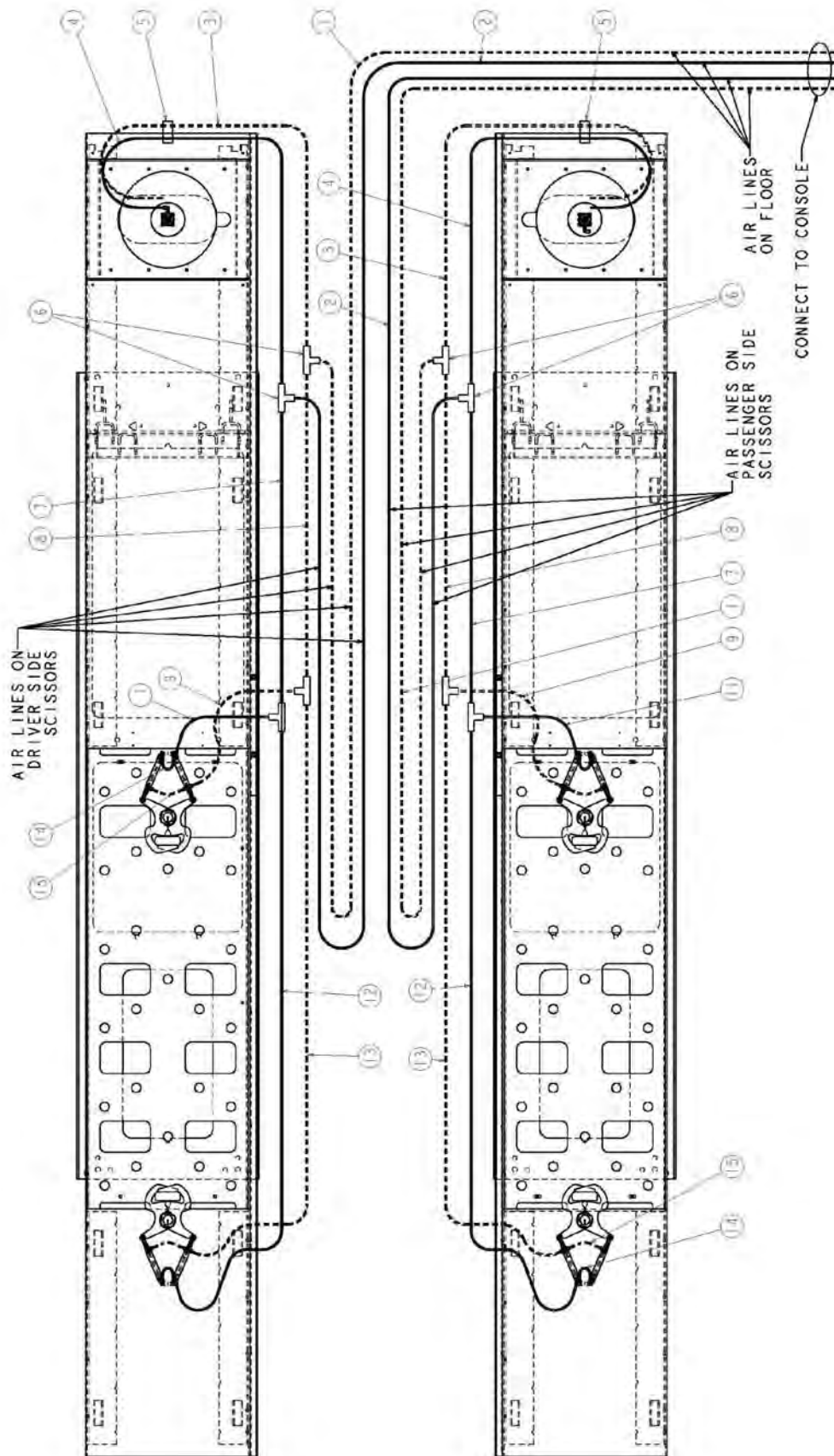

Airline Parts List

Item	Part Number	Description	Location	Qty/Lift
1	1-3733	Air Line, Blue, 1/4", 35'	From Console, on floor, on scissors, up to deck hinge	2
2	1-3732	Air Line, Red, 1/4", 35'	From Console, on floor, on scissors, up to deck hinge	2
3	1-3735	Air Line, Blue, 1/4", 7.8'	On decks, from hinge to front	2
4	1-3734	Air Line, Red, 1/4", 7.8'	On decks, from hinge to front	2
5	6-3950	Tube Clamp	On decks, at front	2
6	6-2971	Fitting, Tee, 1/4"	On decks / On decks, at middle	8
7	1-3736	Air Line, Red, 1/4", 3.1'	On decks, from hinge to middle	2
8	1-3737	Air Line, Blue, 1/4", 3.1'	On decks, from hinge to middle	2
9	1-3741	Air Line, Blue, 1/4", 1.25'	On decks, feeding middle clamp	2
11	1-3740	Air Line, Red, 1/4", 1.25'	On decks, feeding middle clamp	2
12	1-3738	Air Line, Red, 1/4", 8.25'	On decks, middle to rear	2
13	1-3739	Air Line, Blue, 1/4", 8.25'	On decks, middle to rear	2
14	1-3742	Air Line, Red, 1/4", 5"	Between clamp cylinders, rear and middle	4
15	1-3743	Air Line, Blue, 1/4", 7"	Between clamp cylinders, rear and middle	4
*	6-3940	Adhesive Clamps 9/32"	Front to turnplate	2

21.4 Rear LED Light Assembly: Exploded View

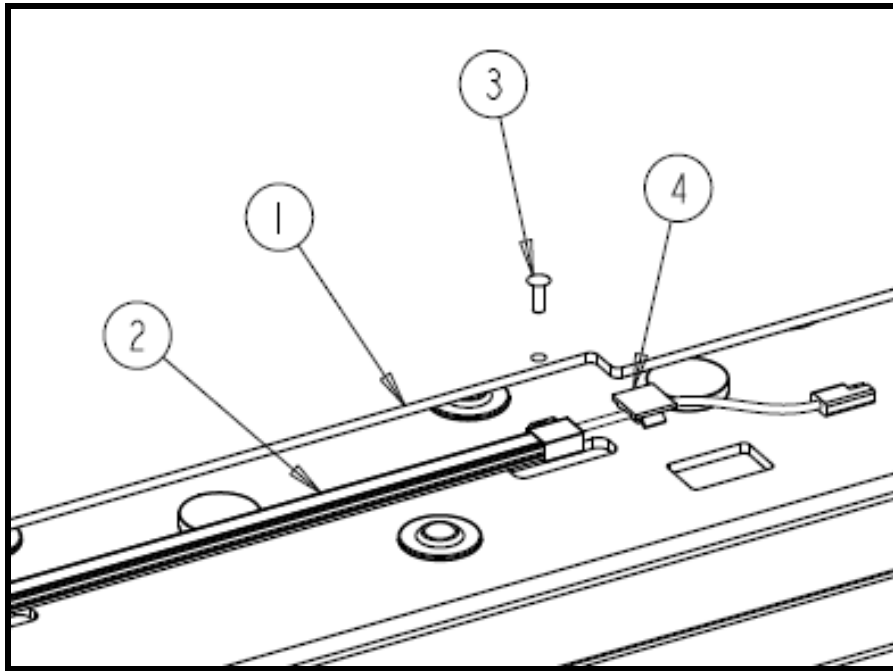

Top of Deck – Rear Slip Plate

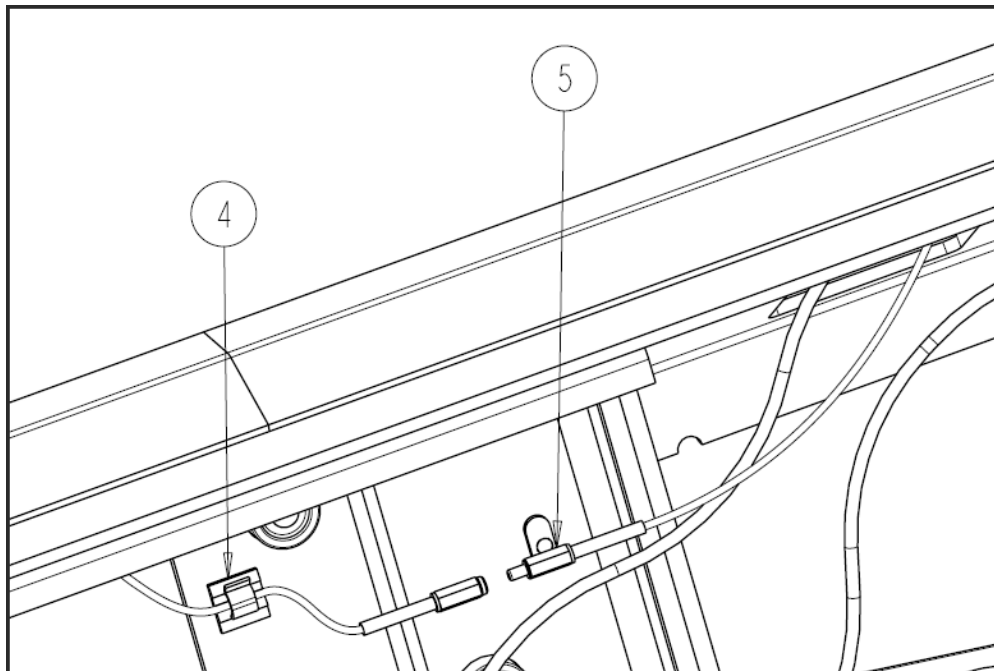

Underside of Deck – Connection of LED Light Bar

*Note: Objects in pictures may not be exactly as shown.

REAR LED LIGHT ASSEMBLY: Parts List

Item #	Part #	Description	Qty.
1	2-2721	Rear Slip Plate Weldment, LS	1
	2-2740	Rear Slip Plate Weldment, RS	1
2	6-4216	LED Light Bar w/ mounts & connector (Left side)	1
	6-4217	LED Light Bar w/ mounts & connector (Right side)	1
3	6-4215	Stainless Steel Rivet 1/4 x 5/8	4
4	6-3940	Adhesive Back Clamps	6
5	6-4089	Cable Extension Assembly (LS)	1
	6-4093	Cable Extension Assembly (RS)	1

21.5 LED CONTROL BOX

Complete Assembly 6-4258

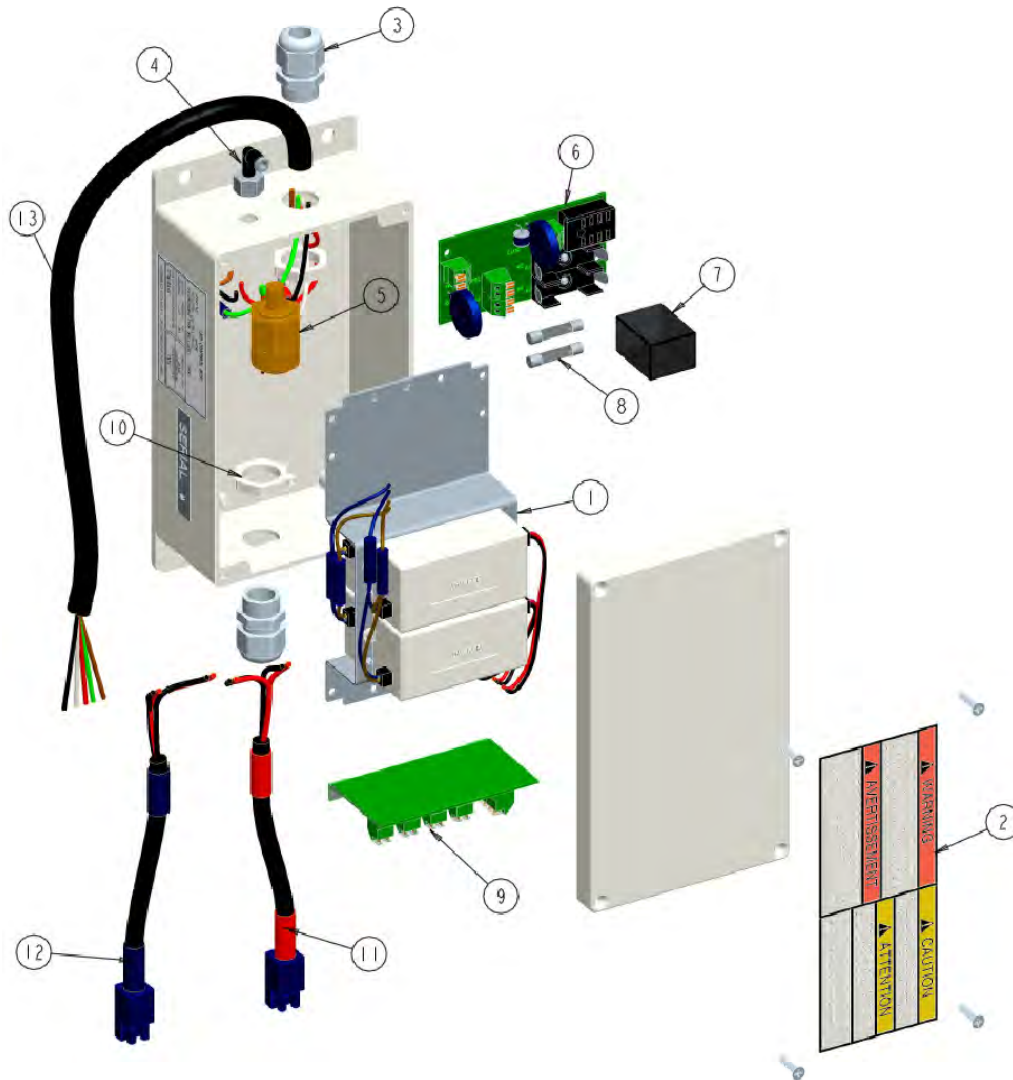

Item#	Part #	Description	Qty.
1	6-4265	LED POWER SUPPLY AND FRAME ASSEMBLY	1
2	6-3957	CONSOLE DECAL	1
3	6-4267	CABLE GLAND, 1/2 NPT	2
4	6-4271	90DEG ELBOW, 1/8NPT - 5/32PLYT	1
5	6-4262	PRESSURE SWITCH	1
6	6-4263	SURGE PROTECT MODULE (SPM)	1
7	6-4260	POWER RELAY, 24VAC DPDT	1
8	6-4261	FUSE, 250V, 2AMP, 6X32mm	2
9	6-4264	TRANSIENT PORTECTION MODULE (TPM)	1
10	6-4266	CABLE NUT, 1/2" NPT	2
11	6-4268	4-POLE CABLE ASSY, RED	1
12	6-4269	4-POLE CABLE ASSY, BLUE	1
13	6-4270	POWER CABLE ASSY, 18/5 SOOW 3FT	1

22.0 CONSOLE ASSEMBLY

22.1 Electrical Panel

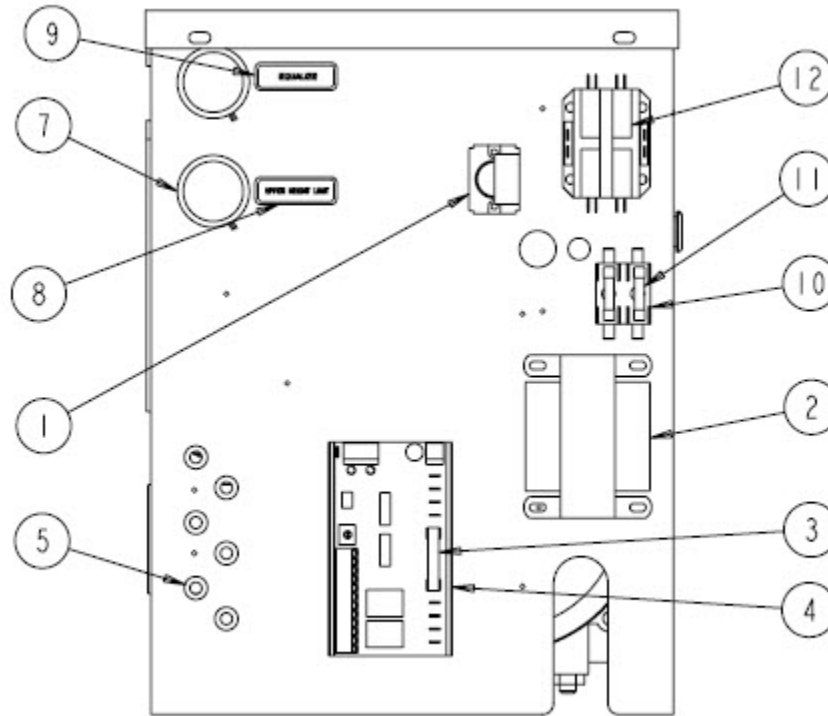

Item #	Part #	Description	Qty.
1	—	Push Button Assembly	1
	6-1247	Push Button	1
	6-1248	Push Button Contact NO	1
2	6-2126	Transformer 230V Primary	1
3	—	Fuse 5A	1
4	6-3280	Circuit Board	1
5	6-3574	Plastic Strain Relief	6
7	6-3941	Pressure Switch w/ Gauge	2
8	6-3067	Decal, "UPPER HEIGHT LIMIT"	1
9	6-3068	Decal, "EQUALIZE"	1
10	6-3595	Fuse Holder – 2 Pole, 20A/250V	1
11	6-3597	Fuse 1A, 250V Time Delay 6x32	2
12	6-4152	Contactor	1

NOTE: Standard Console Assembly is Part # 01617
Optional Console Assembly (Locking & Lighting System) is Part # 01704

***When converting a 1 PH unit to a 3PH unit order all 3PH components marked.

22.2 Console: Pneumatic & Filtering System

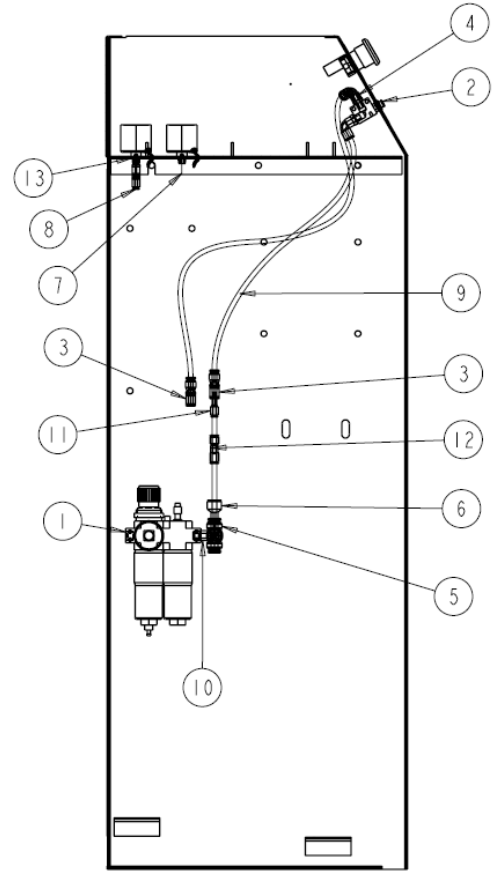

Item #	Part #	Description	Qty.
1	6-4142	Water Separator / Regulator / Lubricator Kit	1
2	6-4275	Air Release Button Assembly (mushroom)	1
3	6-3729	Union 'Y', 1/4" Polytube	2
4	6-0709	Swivel Elbow, 1/8" NPT x 1/4" Polytube	2
5	6-3730	Swivel 'T' Adapter, 1/4" NPT M x 3/8" Polytube	1
6	6-3731	Reducer, 3/8" Stem x 1/4" Polytube	1
7	6-3942	Union, M5 x 4mm Polytube	2
8	6-3985	Branch 'Y', M5 x 4mm Polytube	1
9	8-0141	1/4" Polytube (ft)	5ft
10	6-0015	90° Elbow 1/4 NPT	1
11	6-3928	Reducer	1
12	6-3952	Check Valve, 1/4 Poly	1
13	6-4015	M10 x 1.5 Pushnut Retainer	1

22.3 Console: Pneumatic & Filtering System - Locking & Light System (Optional)

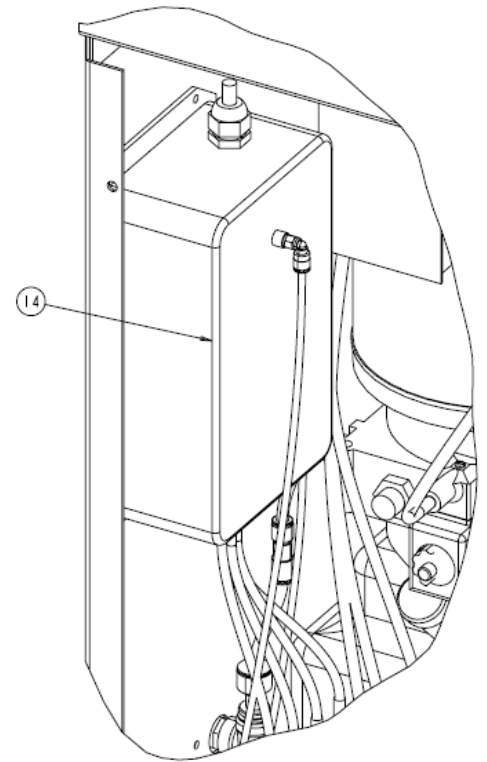
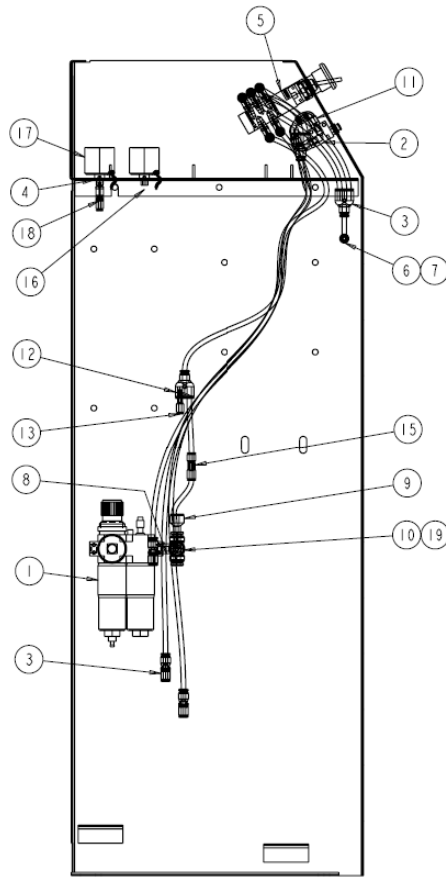

Item #	Part #	Description	Qty.
1	6-4142	Water Separator/Regulator/Lubricator Ass'y	1
2	6-4275	Air Release Button Assembly (mushroom)	1
3	6-3729	Union 'Y', 1/4" Poly	5
4	6-4015	M10 x 1.5 Pushnut Retainer	2
5	6-3905	Valve Assembly (Locking Plates)	1
6	6-0708	Adapter, 1/8" NPT - 1/4" Poly	1
7	6-3977	Breather, Female 1/8" NPT	1
8	6-0015	90° Elbow 1/4 NPT	1
9	6-3731	Reducer, 3/8" Stem x 1/4" Poly	1
10	6-3730	Swivel Tee Adapter, 1/4"NPT x 3/8" Poly	1
11	6-0709	Swivel Elbow, 1/8" NPT M x 1/4" Poly	2
12	6-2971	Pushlock Tee, 1/4" Poly	1
13	6-3928	Reducer, 1/4" Stem x 5/32" (4mm) Poly	1
14	6-4258	LED Driver Box Assembly	1
15	6-3952	Check Valve, 1/4" Poly	1
16	6-3942	Union, M5 X 4mm Polytube	2
17	6-3941	Pressure Switch w/ Gauge	2
18	6-3985	Branch 'Y', M5 x 4mm Polytube	1
19	6-0015	90° Elbow 1/4 NPT	1

22.4 PNEUMATIC LIMIT SWITCH SCHEMATIC

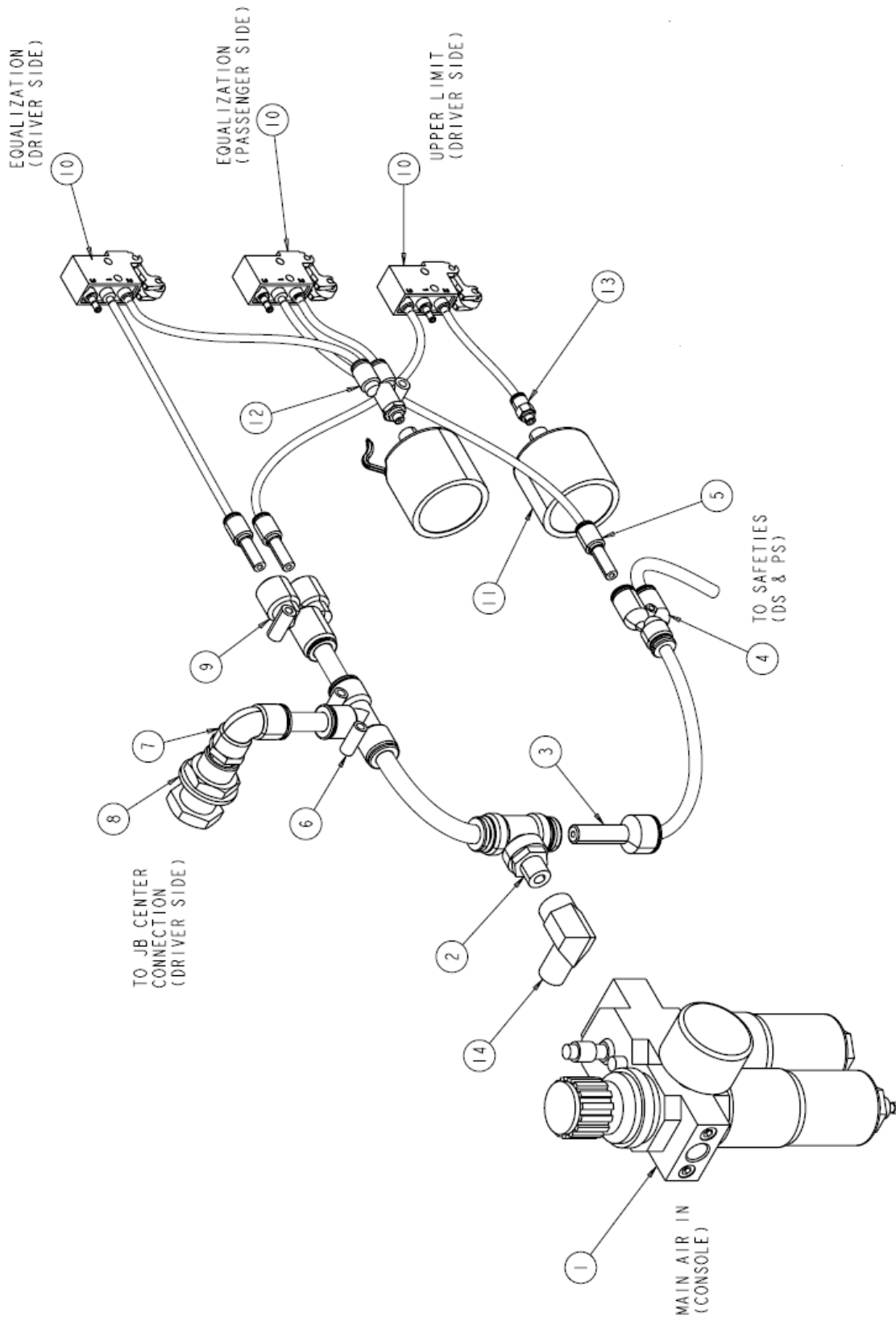

Item #	Part #	Description	Qty.
1	6-4142	Water Separator / Regulator / Lubricator Kit	1
2	6-3730	Swivel 'T' Adapter, 1/4" NPT M x 3/8" Polytube	1
3	6-3731	Reducer, 3/8" Stem x 1/4" Polytube	1
4	6-3729	Union 'Y', 1/4" Polytube	1
5	6-3928	Reducer	3
6	6-3011	Union T, 3/8" Polytube	1
7	6-3010	90 Deg. Elbow, 1/4" NPT-M – 3/8" Polytube	1
8	6-0713	Terminal Bolt, 3/4"	1
9	6-3943	Branch Y, 3/8" Polytube – 1/4" Polytube	1
10	6-3964	Limit Switch, Roller Lever	3
11	6-3941	Pressure Switch	2
12	6-3985	Branch Y, M5 x 4mm Polytube	1
13	6-3942	Union, M5 x 4mm Polytube	1
14	6-0015	90° Elbow 1/4 NPT	1

22.5 Control Panel

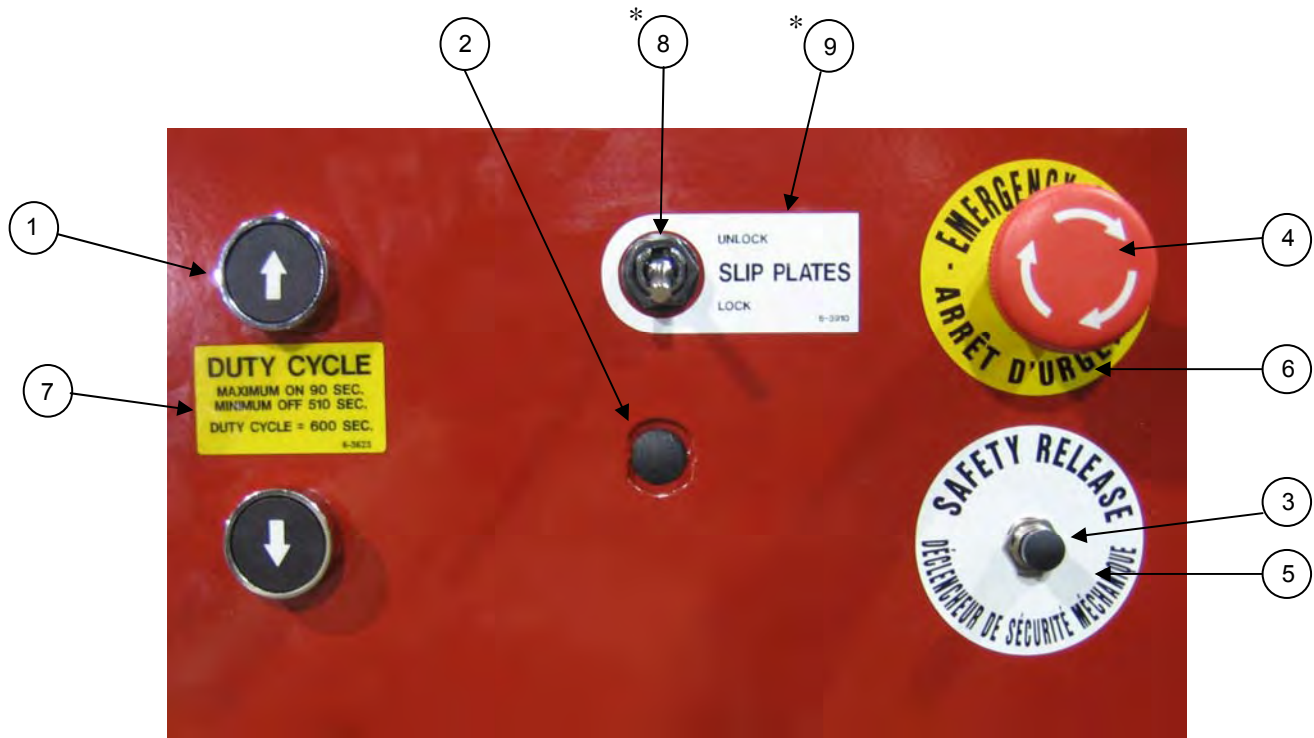

Item #	Part #	Description	Qty.
1	—	Push Button Assembly	2
	6-1247	Push Button - Arrow	1
	6-1248	Push Button Contact NO	1
2	6-2314	Plastic Plug	1
3	—	Air Valve Assembly	1
	6-4275	Air Safety Release Valve (Mushroom Button)	1
	6-0709	90° Elbow, ¼" Polytube x 1/8" M NPT	1
	6-0708	¼" Polytube x 1/8" M NPT Adapter	1
4	—	Emergency Stop Button Assembly	1
	6-2921	Emergency Stop Push Button	1
	6-2922	Emergency Stop Contact NC	1
5	6-3558	Safety Release Decal	1
6	6-3557	Emergency Stop Decal	1
7	6-3623	Duty Cycle Decal	1
* Optional: Locking Turnplates & Slip Plates			
8	6-3905	Valve Assembly	1
9	6-3910	Lock / Unlock Decal	1

22.6 Console Panel Assembly

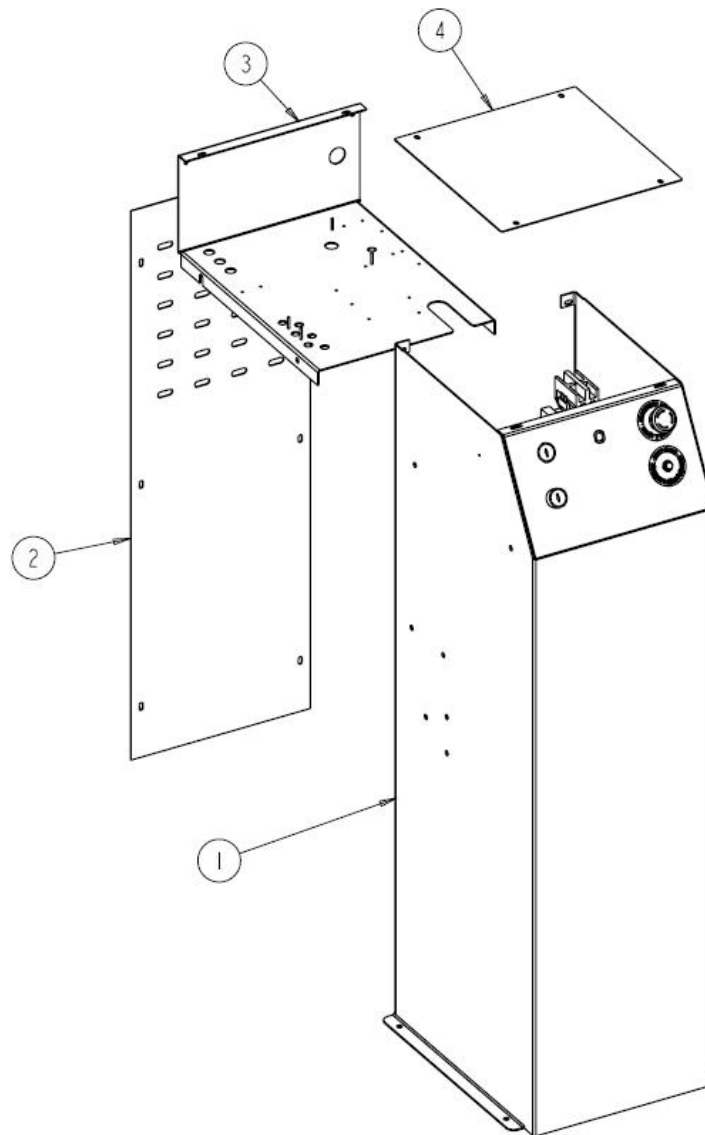

Item#	Part#	Description	Qty.
1	3-0973	Console Front/Side Panel	1
2	2-2512	Console Rear Panel	1
3	3-0974	Electrical Panel	1
4	2-2513	Top Cover	1
includes	6-0141	Concrete Nail 1/4" x 1" Lg.	4
	6-3075	Screw #10-24 x 5/8"	12
	6-3074	U-Type Fastener	12
	6-0816	Flat Washer, #10	12

* Note: may not be exactly as shown.

23.0 POWERPACK ASSEMBLY

23.1 Powerpack Assembly

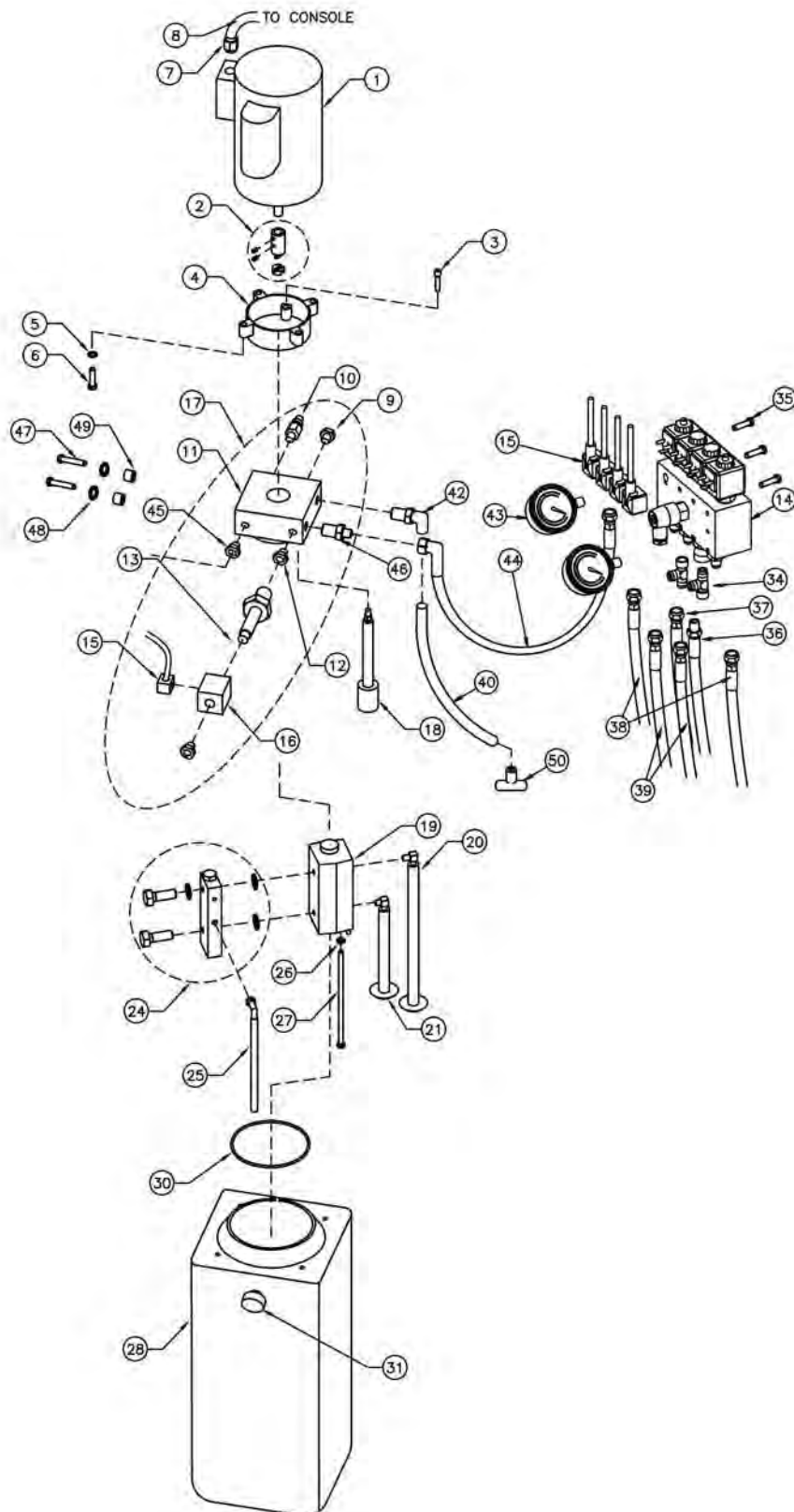

Item #	Part #	Description	Qty.
1	6-0087	Motor, 220V (1 Phase)	1
	6-0446	Motor, 220V (3 Phase)	1
	6-0447	Motor, 575V (3 Phase)	1
2	6-2537	Motor Coupler	1
3	6-2984	Cap Screw, M6x20	2
4	6-2507	Bellhousing	1
5	6-2547	Lock Washer, Internal Tooth, 3/8"	4
6	6-2558	Cap Screw, Hex HD, 3/8"-16UNC x 1 1/2" LG	4
7	6-1370	1/2" Strain Relief Connector (1 Phase)	1
	6-0094	1/2" Strain Relief Connector (3 Phase)	1
9	6-2985	Check Valve	1
10	6-2986	Relief Valve (4650 PSI)	1
11	6-2987	Main Body	1
12	6-2988	Flow Control	1
13	6-2129	Spool Valve (c/w Manual Override)	1
14	6-4338	Manifold Assembly	1
		**See Next Page for Manifold Assembly	
15	1-3625	DIN Connector (24V) Assembly	5
16	6-2128	Square Coil (24V)	1
17	6-2989	Mainbody Assembly	1
18	6-2990	Return Filter Assembly	1
19	6-2991	Tandem Pump	1
20	6-3631	Long Inlet Strainer Assembly	1
21	6-3632	Short Inlet Strainer Assembly	1
24	6-2555	Unloading Manifold Assembly	1
25	6-3633	Return Tube Assembly	1
26	6-0674	Lock Washer, 5/16"	4
27	6-2533	Cap Screw, Hex HD, 5/16"-18UNC x 6 1/2" LG	2
28	6-3638	Oil Tank 15L	1
30	6-2996	Oil Tank O-Ring	1
31	6-3223	Filler / Breather Cap	1
34	6-0284	Tee Fitting 3/8" JIC, F-M-M	2
35	6-3889	BHSCS, 1/4"-20UNC X 1/2" LG	3
36	2-2719	Hydraulic Hose	1
37	2-2718	Hydraulic Hose	1
38	2-2143	Primary Hydraulic Hose	2
39	2-2717	Equalizing Hydraulic Hose	2
40	6-3082	3/8" Polytube Return Lines	2
42	6-3058	90 Deg Elbow 3/8" NPT to 3/8" Polytube	1
43	6-3474	Hydraulic Gauge, 0-5000 PSI	2
44	2-2592	Hydraulic Hose Assembly	1
45	6-3890	Plug (Oil Fill)	1
46	6-3894	Pressure Fitting w/ Bonded Seal	1
47	6-3563	Button Head Screw M10 X 45MM	2
48	6-0215	Spacer	2
49	6-3892	Lock Washer, M10	2
50	6-3011	Pushlock Tee Fitting, 3/8" Poly	1
*NOTE	6-3881	Pump Assembly	

23.2 Manifold Parts List

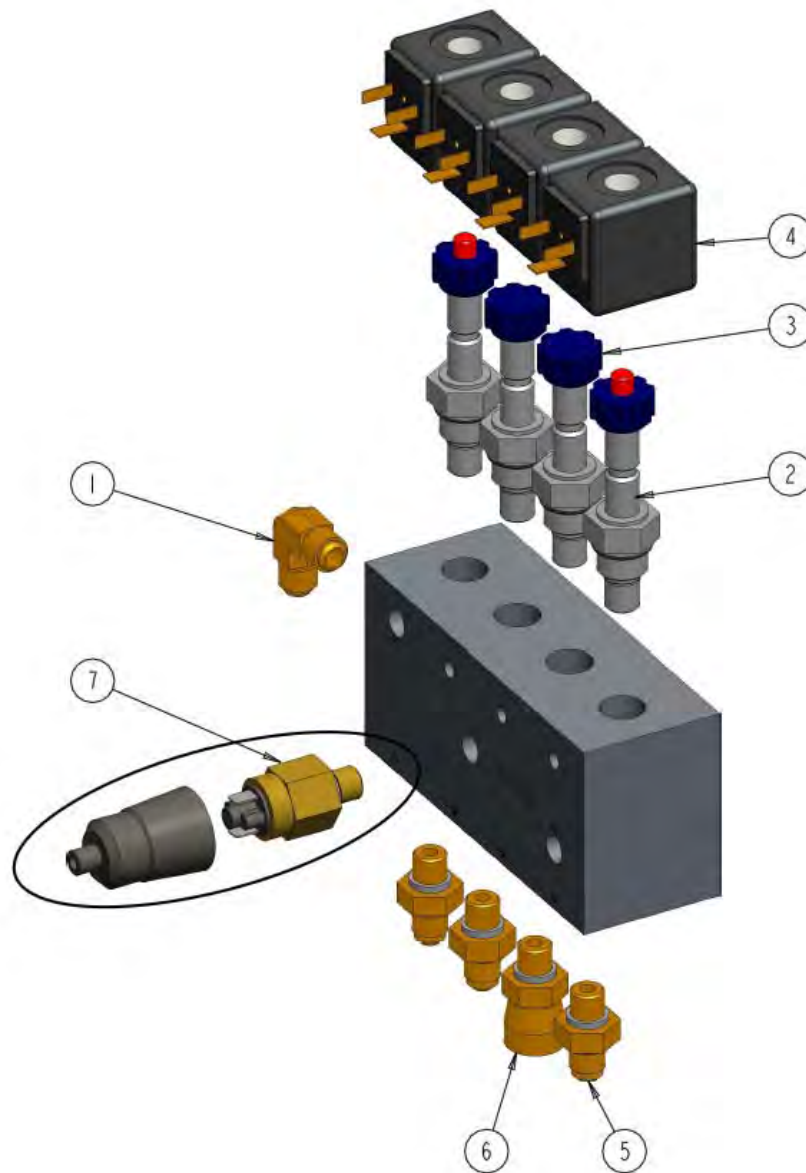

Item#	Part#	Description	Qty.
1	6-3891	90 deg Elbow #6 JIC	1
2	6-2129	Manual Cartridge Valve	2
3	6-3403	Cartridge Valve	2
4	6-2128	Square Coil 24V	4
5	6-3001	Adapter SAE #6 M – 3/8" JIC M	3
6	6-3891	Adapter, Elbow SAE #6 M – 3/8" JIC M	1
7	6-4315	Pressure Switch w/ Cover	1

Note: Complete Assembly Part # 6-4338