

HOFMANN

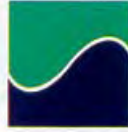

INSTALLATION and OPERATION MANUAL



DLS12012

12,000 LB.
(SYMMETRICAL)

**READ THIS INSTRUCTION MANUAL THOROUGHLY
BEFORE INSTALLING, OPERATING, SERVICING OR
MAINTAINING THE LIFT. SAVE THIS MANUAL.**

HOFMANN
USA

309 Exchange Avenue • Conway, AR 72032
(800) 251-4500 • (501) 505-2662
Fax (501) 450-2085 • www.hofmann-usa.com

HOFMANN
Canada

6500 Millcreek Drive • Mississauga, ONT L5N 2W6
(800) 267-2185
Fax (905) 821-2073 • www.hofmann.ca

JUL 2013 REV.- 6-2925

TABLE OF CONTENTS

1	OWNER / EMPLOYER OBLIGATIONS	3
2	IMPORTANT SAFETY INSTRUCTIONS	4
3	SPECIFICATIONS.....	7
4	CONTENTS	9
5	INSTALLATION REQUIREMENTS AND TOOLS.....	10
	5.1 FOUNDATION.....	10
	5.2 TOOLS REQUIRED.....	10
6	INSTALLATION INSTRUCTIONS.....	11
	6.1 UNPACKING PROCEDURE.....	11
	6.2 BAY LAYOUT	12
	6.3 TOWER POSITIONING AND SETUP	13
	6.4 SAFETY SHUT-OFF BAR INSTALLATION.....	14
	6.5 SAFETY RELEASE CABLE ROUTING AND ADJUSTMENT	16
	6.6 POWER PACK INSTALLATION.....	17
	6.7 HYDRAULIC SYSTEM INSTALLATION.....	18
	6.8 HYDRAULIC SYSTEM BLEEDING	19
	6.9 ROUTING OF EQUALIZATION CABLE	20
	6.10 ARM AND ARM RESTRAINT INSTALLATION.....	22
	6.11 TOWER POSITIONING AND ANCHORING	23
	6.12 SHIMMING OF THE REMAINING TOWER.....	25
7	FINAL CHECK OF ASSEMBLED LIFT	26
8	OPERATING INSTRUCTIONS.....	27
9	OPERATION TEST WITH VEHICLE.....	28
10	LIFT MAINTENANCE GUIDLINES	29
	10.1 SAFETY INSTRUCTIONS	29
	10.2 PERIODIC MAINTENANCE BY OWNER/EMPLOYER	29
11	MAINTENANCE SCHEDULE.....	33
12	SAFETY AWARENESS - AUTOMOTIVE LIFT INSTITUTE (ALI)	ERROR!
	BOOKMARK NOT DEFINED.	
13	TROUBLESHOOTING GUIDE	34
14	LOCK OUT AND TAG OUT INSTRUCTIONS	35
	14.1 ISOLATION AND VERIFICATION PROCEDURES:.....	36
	14.2 RETURNING TO SERVICE:	37

15	EMERGENCY OPERATION: 2-POST LIFT	38
15.1	IF THE MECHANICAL LOCKS ARE NOT ENGAGED:	38
15.2	IF THE MECHANICAL LOCKS ARE ENGAGED:	38
16	PARTS MANUAL	39
16.1	LIFT ASSEMBLY	39
16.2	LIFT ASSEMBLY PARTS LIST	40
16.3	HYDRAULIC SYSTEM	42
16.4	HYDRAULIC SYSTEM PARTS LIST	43
16.5	POWER PACK:	44
16.6	POWER PACK PARTS LIST:	45
17	AVAILABLE ACCESSORIES	46

1 OWNER / EMPLOYER OBLIGATIONS

1. The Owner/Employer shall ensure that lift operators are qualified and that they are trained in the safe use and operation of the lift using the manufacturer's operating instructions; ALI/SM 93-1, ALI Lifting it Right safety manual; ALI/ST-90 ALI Safety Tips card; ANSI/ALI ALOIM-2008, American National Standard for Automotive Lifts - Safety Requirements for Operation, Inspection and Maintenance; ALI/WL Series, ALI Uniform Warning Label Decals/Placards; and in the case of frame engaging lifts, ALI/LP-GUIDE, Vehicle Lifting Points/Quick Reference Guide for Frame Engaging Lifts.
2. The Owner/Employer shall establish procedures to periodically inspect the lift in accordance with the lift manufacturer's instructions or ANSI/ALI ALOIM-2008, **American National Standard for Automotive Lifts - Safety Requirements for Operation, Inspection and Maintenance**; and the Employer shall ensure that the lift inspectors are qualified and that they are adequately trained in the inspection of the lift.
3. The Owner/Employer shall establish procedures to periodically maintain the lift in accordance with the lift manufacturer's instructions or ANSI/ALI ALOIM-2008, **American National Standard for Automotive Lifts - Safety Requirements for Operation, Inspection and Maintenance**; and the Employer shall ensure that the lift maintenance personnel are qualified and that they are adequately trained in the maintenance of the lift.
4. The Owner/Employer shall maintain the periodic inspection and maintenance records recommended by the lift manufacturer's instructions or ANSI/ALI ALOIM-2008, **American National Standard for Automotive Lifts - Safety Requirements for Operation, Inspection and Maintenance**.
5. The Owner/Employer shall display the lift manufacturer's operating instructions; ALI/SM 93-1, ALI **Lifting it Right safety manual**; ALI/ST-90 ALI **Safety Tips card**; ANSI/ALI ALOIM-2008, **American National Standard for Automotive Lifts - Safety Requirements for Operation,**

- Inspection and Maintenance**; ALI/WL Series, ALI **Uniform Warning Label Decals/Placards**; and in the case of frame engaging lifts, ALI/LP-GUIDE, **Vehicle Lifting Points/Quick Reference Guide for Frame Engaging Lifts** in a conspicuous location in the lift area convenient to the operator.
6. The Owner/Operator shall provide necessary lockout/tagout means for energy sources per ANSI Z244.1-1982 (R1993), **Safety Requirements for the Lockout/Tagout of Energy Sources**, before beginning any lift repairs and maintenance.
 7. The Owner/Employer shall not modify the lift in any manner without the prior written consent of the manufacturer.

2 IMPORTANT SAFETY INSTRUCTIONS

1. **When using this lift, basic safety precautions should always be followed, including the following:**
2. Read all instructions in this manual and on the lift thoroughly before installing, operating, servicing or maintaining the lift.
3. Care must be taken as burns can occur from touching hot parts.
4. Do not operate equipment with a damaged cord or if the equipment has been dropped or damaged – until it has been examined by a qualified service person.
5. Do not let a cord hang over the edge of the table, bench, or counter or come in contact with hot manifolds or moving fan blades.
6. If an extension cord is necessary, a cord with a current rating equal to or more than that of the equipment should be used. Cords rated for less current than the equipment may overheat. Care should be taken to arrange the cord so that it will not be tripped over or pulled.
7. Always unplug equipment from electrical outlet when not in use. Never use the cord to pull the plug from the outlet. Grasp plug and pull to disconnect.
8. Let equipment cool completely before putting away. Loop cord loosely around equipment when storing.
9. To reduce the risk of fire, do not operate equipment in the vicinity of open containers of flammable liquids (gasoline).
10. Adequate ventilation should be provided when working on operating internal combustion engines.
11. Keep hair, loose clothing, fingers, and all parts of body away from moving parts.
12. To reduce the risk of electric shock, do not use on wet surfaces or expose to rain.

13. Use only as described in this manual. Use only manufacturer's recommended attachments.
14. **ALWAYS WEAR SAFETY GLASSES.** Everyday eyeglasses only have impact resistant lenses, they are not safety glasses.
15. Inspect lift daily. Do not operate if it malfunctions or problems have been encountered.
16. Never attempt to overload the lift. The manufacturer's rated capacity is shown on the identification label on the power side column. Do not override the operating controls or the warranty will be void.
17. Before driving vehicle between the towers, position the arms to the drive-through position to ensure unobstructed clearance. Do not hit or run over arms as this could damage the lift and/or vehicle.
18. Only trained and authorized personnel should operate the lift. Do not allow customers or bystanders to operate the lift or be in the lift area.
19. Position the lift support pads to contact the vehicle manufacturers recommended lifting points. Raise the lift until the pads contact the vehicle. Check pads for secure contact with the vehicle. Check all arm restraints and insure they are properly engaged. Raise the lift to the desired working height.
20. Some pickup trucks may require an optional truck adapter to clear running boards or other accessories.
21. **NOTE:** Always use all 4 arms to raise and support vehicle.
22. Caution! Never work under the lift unless the mechanical safety locks are engaged.
23. Note that the removal or installation of some vehicle parts may cause a critical load shift in the center of gravity and may cause the vehicle to become unstable. Refer to the vehicle manufacturer's service manual for recommended procedures.
24. Always keep the lift area free of obstruction and debris. Grease and oil spills should always be cleaned up immediately.
25. Never raise vehicle with passengers inside.
26. Before lowering check area for any obstructions.
27. Before removing the vehicle from the lift area, position the arms to the drive-thru position to prevent damage to the lift and /or vehicle.
28. Do not remove hydraulic fittings while under pressure.
29. For additional safety instructions regarding lifting, lift types, warning labels, preparing to lift, vehicle spotting, vehicle lifting, maintaining load stability, emergency procedures, vehicle lowering, lift limitations, lift maintenance, good shop practices, installation, operator training and owner/employer responsibilities, please refer to "**Lifting It Right**" (ALI/SM) and "**Safety**

Tips” (ALI/ST) and **vehicle lift points for service garage lifting** SAE J2184.

30. For additional instruction on general requirements for lift operation, please refer to **“Automotive Lift-Safety Requirements For Operation, Inspection and Maintenance”** (ANSI/ALI ALOIM).
31. Installation shall be performed in accordance with ANSO/ALI ALIS, Safety Requirements for Installation and Service of Automotive Lifts.



ATTENTION! This lift is intended for indoor installation only. It is prohibited to install this product outdoors. Operating environment temperature range should be 41 – 104 °F (5 – 40 °C). Failure to adhere will result in decertification, loss of warranty, and possible damage to the equipment.

SAFETY INSTRUCTIONS

If attachments, accessories or configuration modifying components that are located in the

load path, affect operation of the lift, affect the lift electrical listing or affect intended vehicle accommodation are used on this lift and, if they are not certified for use on this lift, then the certification of this lift shall become null and void. Contact the participant for information pertaining to certified attachments, accessories or configuration modifying components.

www.autolift.org

©2007 by ALI, Inc.

ALI / WLSIAO1

+ 070126-Quadra-WLSIAO1

SAVE THESE INSTRUCTIONS









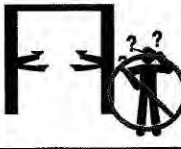

Note: Some images in this manual are generic and may not resemble the lift you have purchased.

3 SAFETY AWARENESS - AUTOMOTIVE LIFT INSTITUTE (ALI)

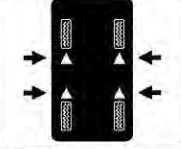
Please refer to these important instructions located on your lift.

Automotive Lift Institute, Inc WL101 Series Label Kit

<p>NOTICE</p>  <p>Read operating and safety manuals before using lift.</p>	<p>NOTICE</p>  <p>Proper maintenance and inspection is necessary for safe operation.</p>
<p>NOTICE</p>  <p>Do not operate a damaged lift.</p>	<p>The messages and pictographs shown are generic in nature and are meant to generally represent hazards common to all automotive lifts regardless of specific style.</p> <p>Funding for the development and validation of these labels was provided by the Automotive Lift Institute, PO Box 85 Cortland, NY 13045.</p> <p>Replacement label sets may be obtained from the original lift manufacturer and ALI's member companies. They are protected by copyright.</p> <p>www.autolift.org © 2009 by ALI, Inc. ALI/WL101s</p>

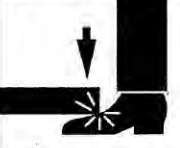
<p>CAUTION</p>  <p>Lift to be used by trained operator only.</p>	<p>CAUTION</p>  <p>Authorized personnel only in lift area.</p>	<p>WARNING</p>  <p>Clear area if vehicle is in danger of falling.</p>	<p>WARNING</p>  <p>Position vehicle with center of gravity midway between adapters.</p>
<p>CAUTION</p>  <p>Use vehicle manufacturer's lift points.</p>	<p>CAUTION</p>  <p>Always use safety stands when removing or installing heavy components.</p>	<p>WARNING</p>  <p>Remain clear of lift when raising or lowering vehicle.</p>	<p>WARNING</p>  <p>Avoid excessive rocking of vehicle while on lift.</p>
<p>CAUTION</p>  <p>Use height extenders when necessary to ensure good contact.</p>	<p>CAUTION</p>  <p>Auxiliary adapters may reduce load capacity.</p>	<p>WARNING</p>  <p>Do not override self-closing lift controls.</p>	<p>WARNING</p>  <p>Keep feet clear of lift while lowering.</p>
<p>The messages and pictographs shown are generic in nature and are meant to generally represent hazards common to all automotive lifts regardless of specific style.</p> <p>Funding for the development and validation of these labels was provided by the Automotive Lift Institute, PO Box 85 Cortland, NY 13045.</p> <p>Replacement label sets may be obtained from the original lift manufacturer and ALI's member companies. They are protected by copyright.</p> <p>www.autolift.org © 2009 by ALI, Inc. ALI/WL101c</p>		<p>The messages and pictographs shown are generic in nature and are meant to generally represent hazards common to all automotive lifts regardless of specific style.</p> <p>Funding for the development and validation of these labels was provided by the Automotive Lift Institute, PO Box 85 Cortland, NY 13045.</p> <p>Replacement label sets may be obtained from the original lift manufacturer and ALI's member companies. They are protected by copyright.</p> <p>www.autolift.org © 2009 by ALI, Inc. ALI/WL101e</p>	

4 SPECIFICATIONS

Maximum Capacity:
 Maximum Arm Capacity:
 Overall Width:
 Width Between Columns:
 Drive-Thru Width:
 Overall Height (12ft Model):
 Under Bar Clearance (12ft Model):
 Height to Lowered Lift Pads:
 Height to Lift Pad (3" Adapter):
 Height to Lift Pad (6" Adapter):
 Retracted Arm Length:
 Extended Arm Length:
 Maximum Lifting Height (6" Adapter):
 Lifting Time:
 Lowering Time:
 Power Requirements (Standard):
 Maximum Hydraulic Pressure @ rated load:

12000 lbs.	5443 kg
3000 lbs	1361 kg
146"	3708 mm
120"	3048 mm
109"	2769 mm
144"	3658 mm
139"	3526 mm
5 1/2"	140 mm
8 3/4"	220 mm
11 1/2"	292 mm
34"	864 mm
52 3/4"	1340 mm
80"	2031 mm
55 seconds	
45 seconds	
230 Volts AC, 1 Ph., 60Hz.	
1600 psi	

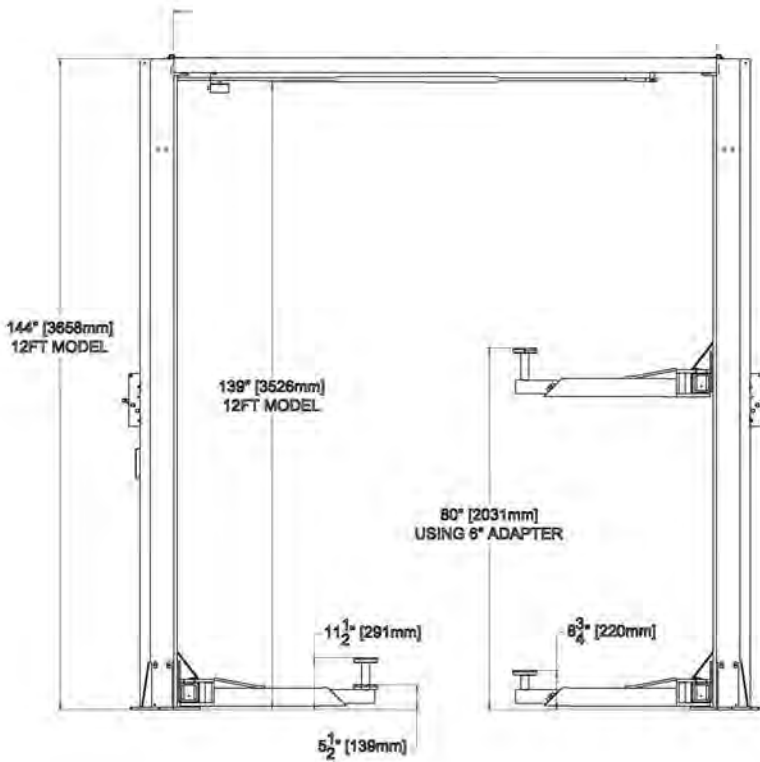

Figure 1 – Front View

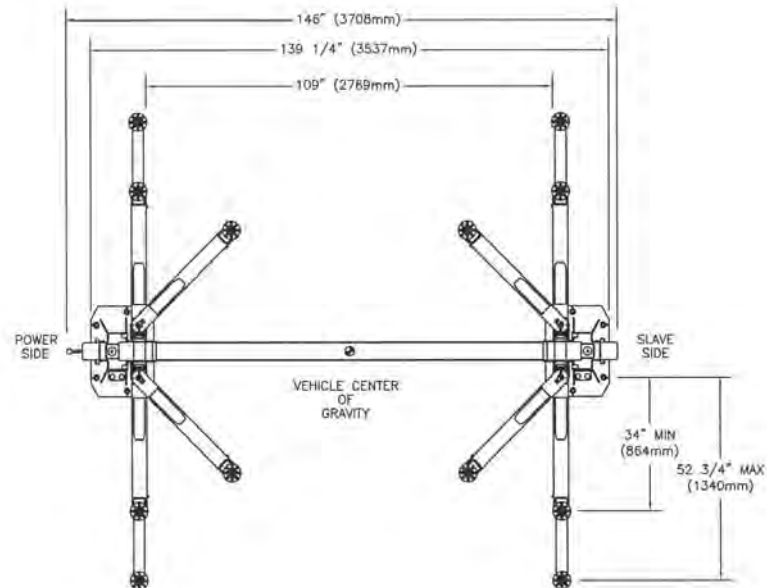

Figure 2 – Top View

5 CONTENTS

The complete lift is contained in two (2) packages:

1. The **main structural components** are packed in a steel frame.
2. The remaining parts are packed in an **accessory box**.

Main Structural Components includes:

- 1pc. - Power side tower and carriage assembly
- 1pc. - Slave side tower and carriage assembly
- 1pc. - Crossmember assembly
- 1pc. - Actuator Bar w/ foam

Accessory box contents:

- 4pcs. - Locking Arm Assembly w/arm pins
- 2pcs. - Safety Covers w/Decals
- 1pc. - Hardware Package w/Packing List
- 1pc. - Actuator Extension
- 1pc. - Actuator Mounting Bracket
- 1pc. - Power Pack
- 4pc. - Arm Restraint
- 4pc. - Stack Pad Assembly
- 4pc. - Stack Pad Adapter (3")
- 4pc. - Stack Pad Adapter (6")
- 1pc. - Safety Release Cable
- 1pc. - Hydraulic Hose (Long)
- 1pc. - Hydraulic Hose (Short)
- 2pcs. - Equalizing Cable w/Hex Nuts
- 1pc. - ALI manual "Lifting It Right"
- 1pc. - Automotive Lift Safety Tips
- 1pc. - Automotive Lift, Operation, Inspection and Maintenance manual
- 1pc. - "ALI" Quick Reference Guide
- 1pc. - Owner's manual
- 1pc. - Safety Shut-off Microswitch Assembly (Components)

6 INSTALLATION REQUIREMENTS AND TOOLS

6.1 FOUNDATION

IMPORTANT: It is the user's responsibility to provide a satisfactory installation area for the lift. Lifts should only be installed on level concrete floors with a minimum thickness of six inches (6") or 152 mm. Concrete must have a minimum strength of 4000 psi or 28 MPa and should be aged thirty (30) days prior to installation. Please consult the architect, contractor or engineer if doubt exists as to the strength and feasibility of the floor to enable proper lift installation and operation.

A qualified person should be consulted to address seismic loads and other local or state requirements.

It is the user's responsibility to provide all wiring for electrical hook-up prior to installation and to insure that the electrical installation conforms to local building codes. Where required, it is the user's responsibility to provide an electrical isolation switch located in close proximity to the lift that will enable emergency stop capability and isolate electrical power from the lift for any servicing requirements.

6.2 TOOLS REQUIRED

- a. 16ft. Measuring Tape
- b. Chalk Line
- c. Rotary Hammer Drill
- d. 3/4" diameter Masonry Drill Bit
- e. Hammer
- f. SAE Wrenches and Ratchet Set
- g. 2ft. Level
- h. 4ft. Level
- i. Crow Bar
- j. 12ft. Step Ladder (alternate means required when installing tower extensions)
- k. Side Cutters
- l. Screwdrivers
- m. 4" x 4" Wooden Blocks (for unpacking)
- n. 4.5 gal. (18L) Hydraulic Fluid
- o. Impact Wrench
- p. Torque Wrench
- q. Bleed hose
- r. Wherever LOCTITE symbol is shown, apply LOCTITE #242 on required fasteners. If fasteners are removed reapply LOCTITE before re-installing.



7 INSTALLATION INSTRUCTIONS

1. When the lift arrives on site:
2. Read the owner's manual and make sure the installation instructions are fully understood.
3. Check for any freight damages.
4. Check the contents of the accessory and hardware boxes to make sure no parts are missing.
5. Gather all the tools listed above.

7.1 UNPACKING PROCEDURE

1. **Important!** Place the main structural components on wooden blocks so that the steel shipping frames can be removed.
2. Remove the plastic wrapping.
3. Remove the crossmember assembly, and the actuator bar.
4. Unbolt the steel shipping frames.
5. Lay each tower on the floor with the carriage side up.
6. Check the installation area for obstructions. (Lights, Heating Ducts, Ceiling, Floor Drains, etc.)

7.2 BAY LAYOUT

1. Prepare the bay by selecting the location of the lift relative to the walls.
2. Clear the installation area of all packaging materials to avoid trip hazards.
3. Measure midpoint of door.
4. Using measuring tape scribe two arcs, equal distance from the midpoint.
5. The centerline of the lift occurs between the intersection of the arcs and the midpoint of the door.

Note: Leave any additional room for any desired aisle or work area. Recommended minimum clearance around lift is three feet (3 ft) and above lift is four inches (4"). Ensure clearance conforms to local building and fire codes.

6. Measure the specified distance (126") to draw a second chalk line at 90° for locating the lift towers. Refer to Figure 3.
7. The lift is centered between the door and the walls of the area.

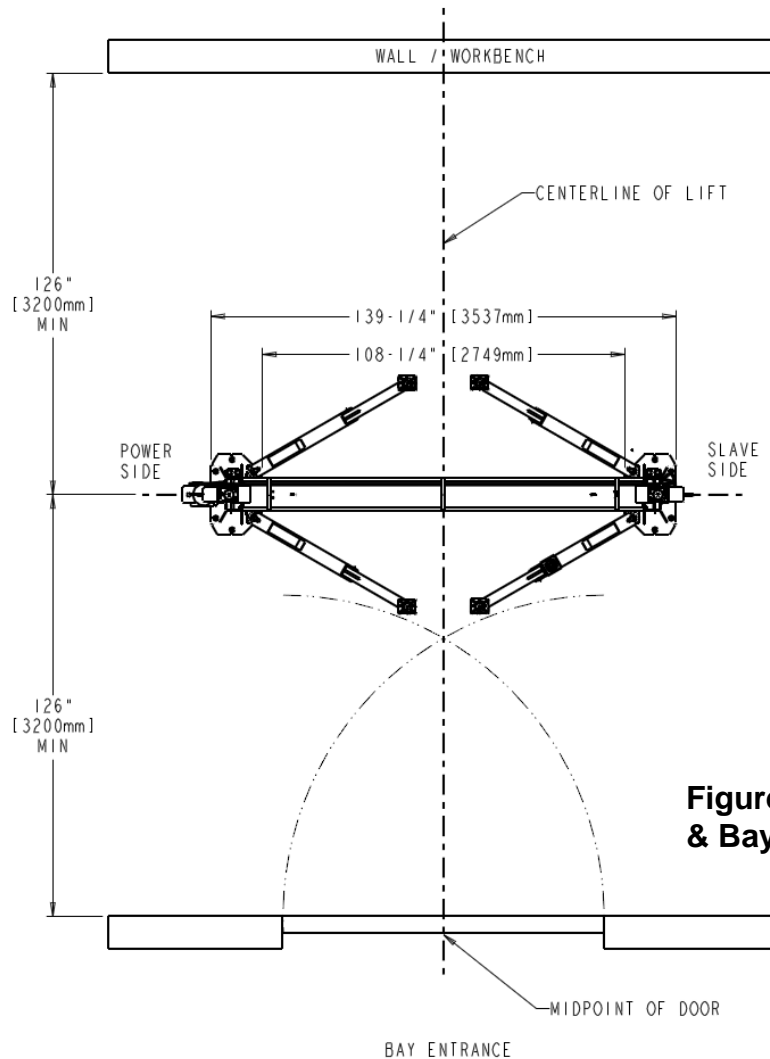

Figure 3. Chalk line & Bay Layout

7.3 TOWER POSITIONING AND SETUP

1. Install the safety pulley on each tower as shown in **Figure 4**.
2. Attach the safety pulley to the tower using the 3/8" x 5/8" LG. shoulder bolt, 5/16" lockwasher and 5/16" hex nut.

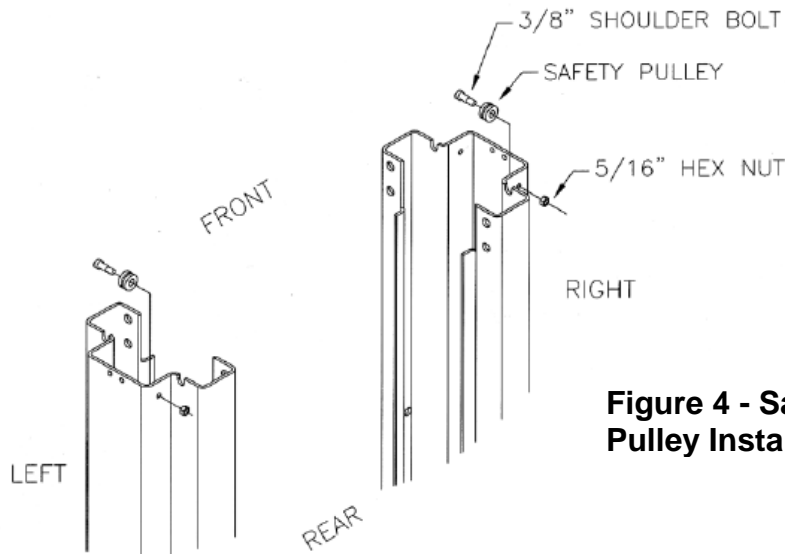

Figure 4 - Safety Release Pulley Installation

3. Locate the power side and slave side towers and position them as shown in **Figure 3**. Double check all the dimensions in the layout.
4. Using a stepladder, install the crossmember using eight (8) 1/2"-16UNC x 1 1/2" lg. hex head bolts, eight (8) 1/2" ID lock washers, eight (8) 1/2" hex nuts and eight (8) 1/2" flat washers. See **Figure 5**.
5. Check the towers to make sure they are located, and positioned in the correct location. **Figure 3**.

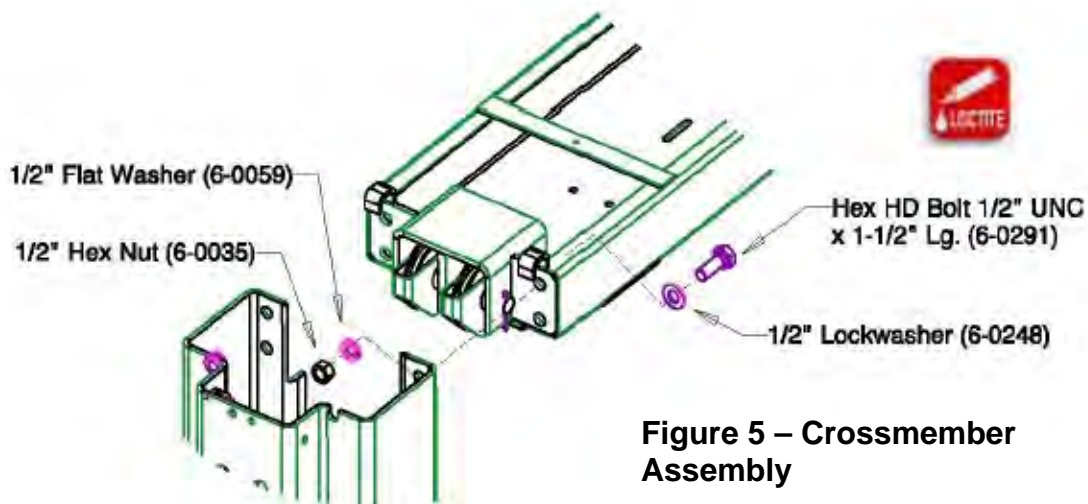

Figure 5 – Crossmember Assembly

7.4 SAFETY SHUT-OFF BAR INSTALLATION

Note: The safety shut off will disconnect the power to the power pack when an obstruction touches the padded bar or the carriages reach their maximum height. The safety shut off switch is factory pre-wired. Refer to **Figure 8**.

1. Attach the Actuator Mounting Bracket to the crossmember using one (1) 1/4"-NC x 1" lg. hex head bolt, one (1) 1/4"ID lockwasher, and one (1) 1/4" NC hex nut. The mounting bracket should be installed in one of center slots at either end of the crossmember. (**Figure 6**)

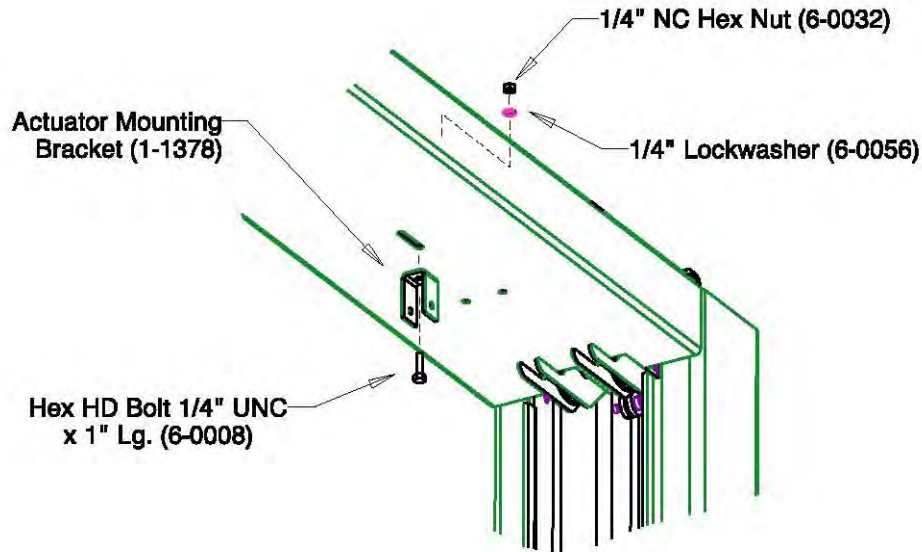

Figure 6: Actuator Mounting Bracket

2. Attach the Actuator Bar to the Actuator Mounting Bracket using one (1) 1/4" NC x 1 1/2" lg. hex head bolt, one (1) 1/4" lockwasher, and one (1) 1/4" NC hex nut. Orient the Actuator Bar so that the last hole (out of the set of 3) is used when mounting. (**Figure 7**)

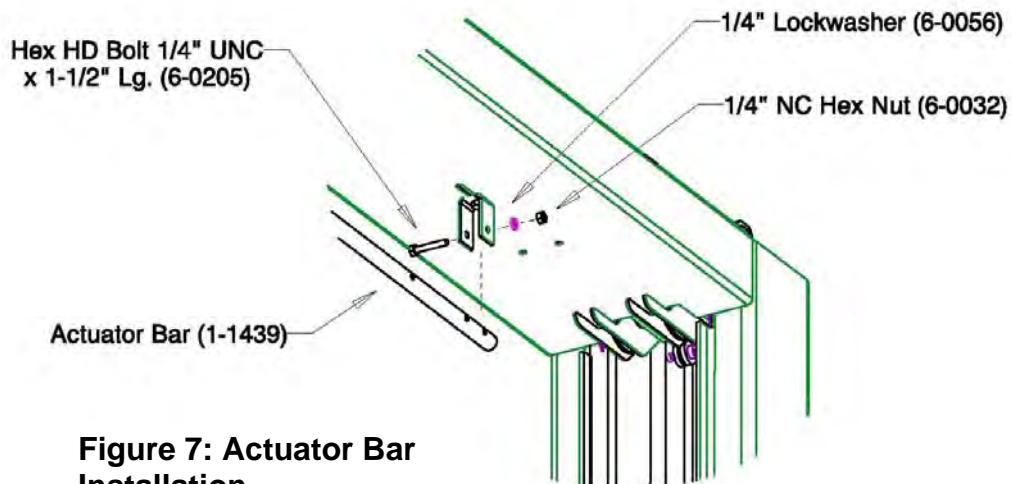

Figure 7: Actuator Bar Installation

- Slide the Microswitch Assembly over the far end of the Actuator Bar.
Attach the Microswitch Assembly to the crossmember bar using two (2) 1/4" NC x 1" lg hex head bolts, two (2) 1/4" ID lockwashers, and two (2) 1/4" NC hex nuts.

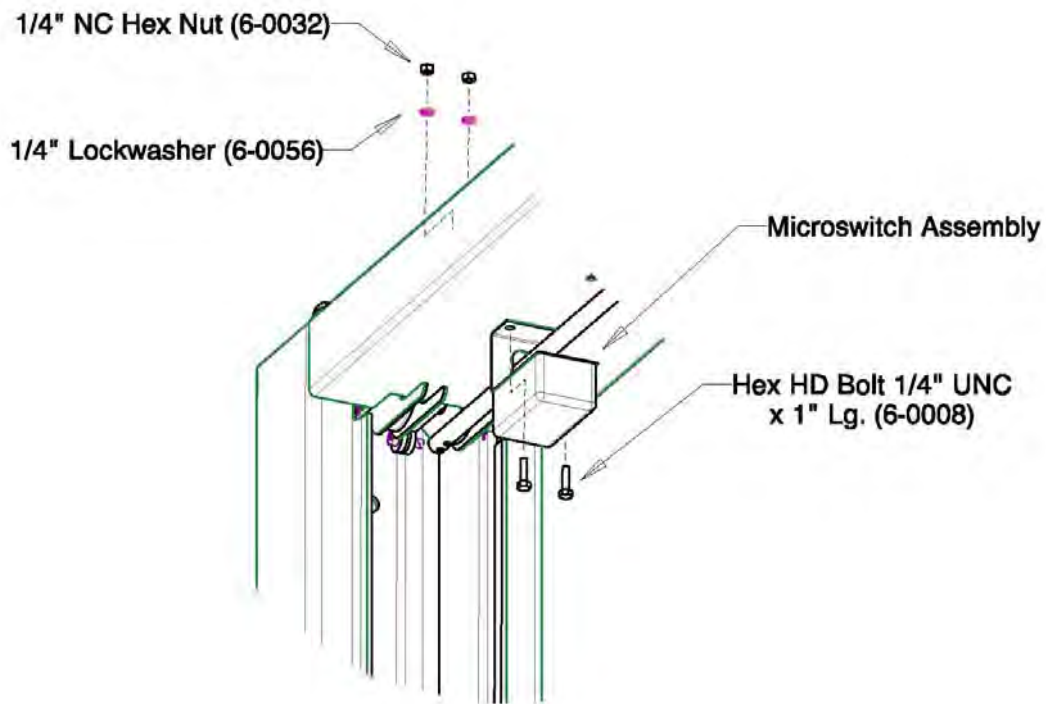

Figure 8: Mounting Microswitch

- Install the 90° degree conduit elbow to the actuator bar. The actuator extension should then be installed in the conduit elbow. Ensure the bolts in the elbow are fully tightened.

7.5 SAFETY RELEASE CABLE ROUTING AND ADJUSTMENT

The mechanical safety automatically engages. To release the mechanical safety, you must first raise the lift approximately 2" then pull the safety release lever down. This disengages the power side safety dog and activates the safety cable to release the slave side safety dog.

1. Refer to **Figure 9** for safety release cable routing.
2. The end with the collar is to be installed onto the slave side tower, while the loose end will be installed onto the power side tower with two (2) wire rope clips.

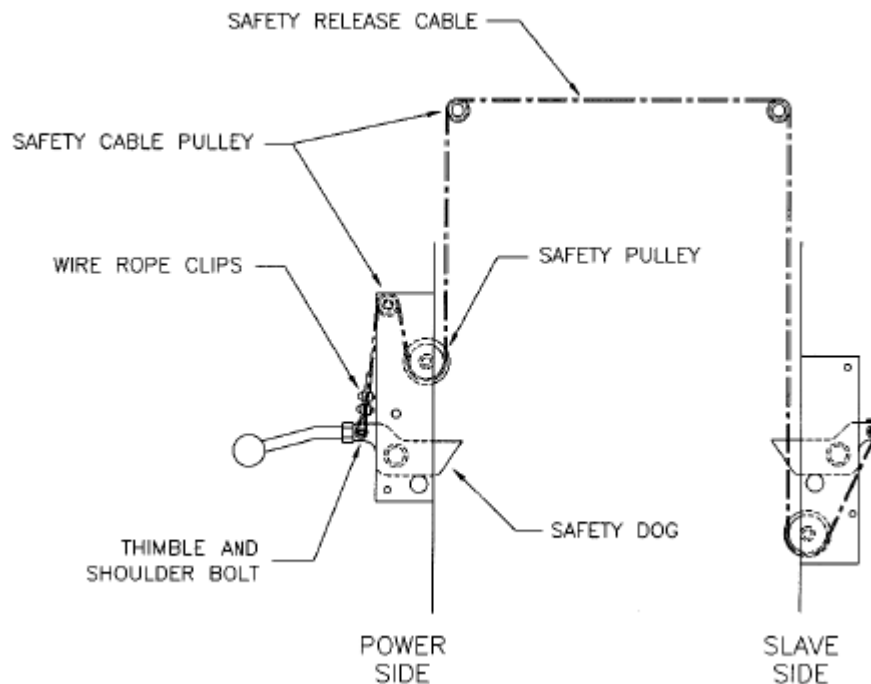

Figure 9 – Safety Release Cable Routing and Adjustment

3. Install the safety release handle onto the power side safety dog.
4. Start routing the safety release cable from the slave side of crossmember. Feed the cable over the small pulley then guide the cable down along the inside of the slave side tower. Pull the cable out through the opening in the back of the tower near the safety dog.
5. Guide the cable up under the large pulley towards the end of the safety dog. Remove the 3/8" x 1 1/2" shoulder bolt from the safety dog. Feed the shoulder bolt through the collar of the safety release cable and then replace the shoulder bolt securely to the safety dog.



NOTE: Make sure the shoulder bolt, 3/8" dia. x 1 1/2" lg. (6-0801), is lock tight to safety dog.

6. Repeat step 3 for the power side tower.
7. Guide the cable up under the large pulley and then over the small pulley towards the safety dog as shown in **Error! Reference source not found.** Wrap the cable around the thimble (attached to the safety dog with a 3/8" x 1 1/2" lg. shoulder bolt) and then clamp it using two (2) wire rope clips. **Do not tighten fully at this stage.**
8. Adjust the cable length so that both safety dogs travel from full engagement position to full release position when the safety release handle is pulled.

Tighten both wire rope clips firmly when adjustment is completed.

7.6 POWER PACK INSTALLATION

1. Remove the **red** plastic cap located at the rear of the power pack, and install the "T" fitting located in the hardware kit.
2. Bolt power pack to the mounting bracket on the power side tower using four (4) 5/16" UNC x 1" LG. hex head bolts, four (4) 5/16" ID lock washers, four (4) 5/16" ID flat washers and four (4) 5/16" UNC hex nuts. Do not tighten.
3. Remove the filler cap from the powerpack and fill the reservoir with approximately 4.2 Gal. (16L) of ISO32 hydraulic oil (10 wt. hydraulic oil).
4. A **certified electrician** must connect power to the motor. The electrical diagram is provided, refer to **Figure 10**.

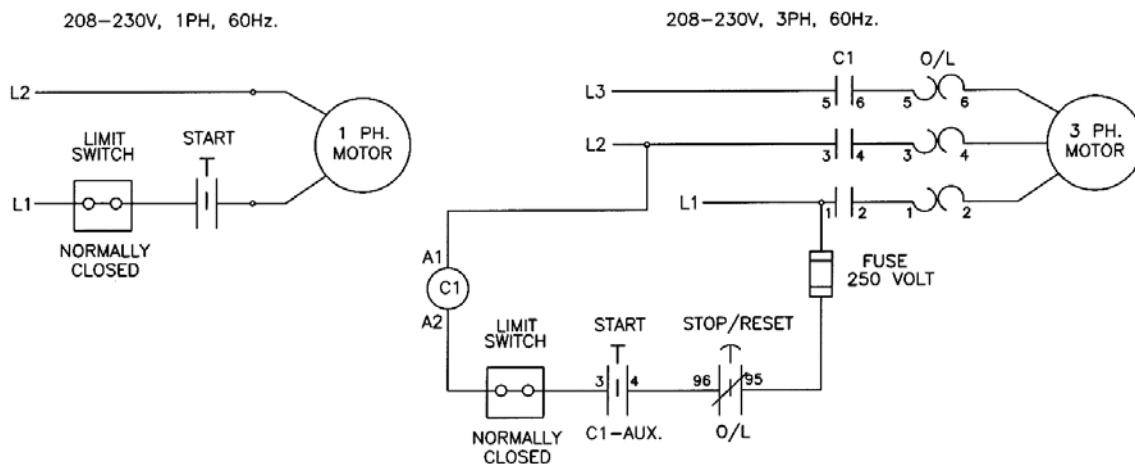
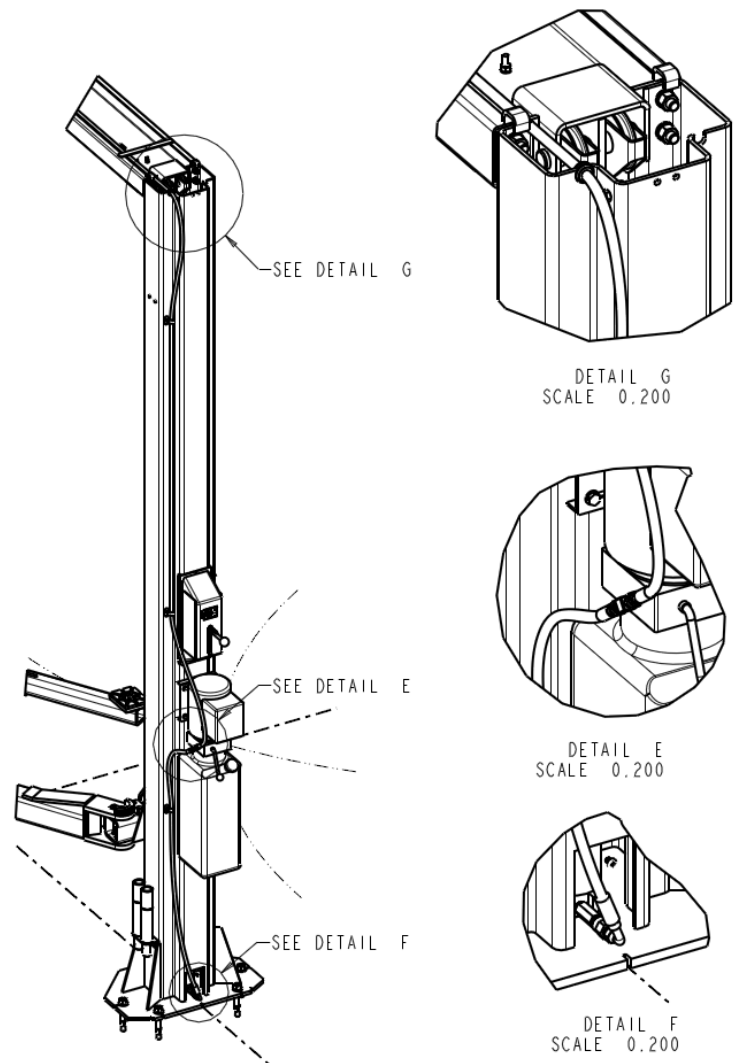

Figure 10 – Electrical Diagram

7.7 HYDRAULIC SYSTEM INSTALLATION

REFER TO HYDRAULIC PARTS LIST

1. Connect the straight end of the short hydraulic hose to the bottom port of the "T" fitting on the powerpack.
2. Remove the cap from the bottom of the power side cylinder and connect the other end of the short hydraulic hose.
3. Connect the straight end of the long hydraulic hose to the top port of the "T" fitting on the powerpack.
4. Loop the long hydraulic hose up the power side tower, across the overhead and down the slave side tower.
5. Remove the cap from the slave side cylinder and attach the other end of the long hydraulic hose.
6. The long hydraulic hose must be fixed to the towers using six (6) hose clamps (3 on each side). Screw the hose clamps into the weld nuts on the towers using 1/4" UNC x 3/8"lg. round head screws.
7. The long hydraulic hose must be fixed to the crossmember using two (2) hose clamps. Screw the hose clamps into the crossmember using #10 x 3/8" lg. self-threading screws.



7.8 HYDRAULIC SYSTEM BLEEDING

1. Crack the bleeder valve located at the top of both cylinders. (Approx. a $\frac{1}{4}$ turn)
2. Power up 2" – 3". You should hear air escaping around the bleeder valve. Repeat until oil is flowing out of the bleeder valve.
3. Tighten the bleed screw and lower the lift.

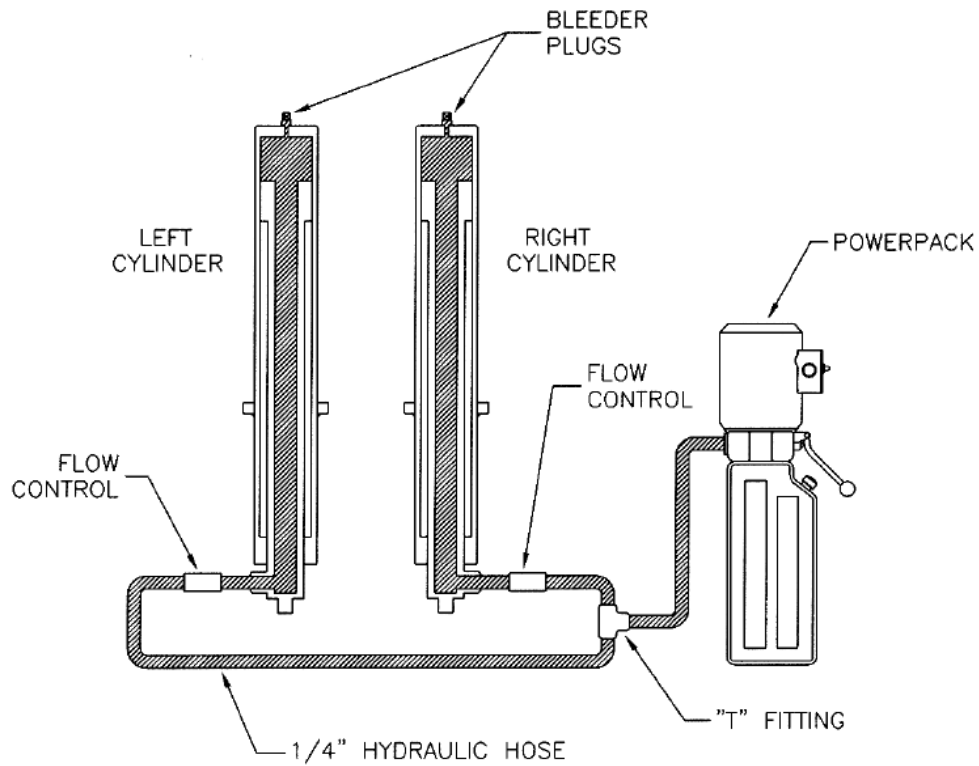

Figure 11: Powerpack installation

7.9 ROUTING OF EQUALIZATION CABLE

1. Manually move the carriages until they reach the first safety latch.
2. Remove equalizing cables from the accessory kit box, and locate the (8) $\frac{1}{2}$ "-13UNC nuts in the hardware kit box.
3. Equalizing cables are to be routed as shown in **Figure 12**.

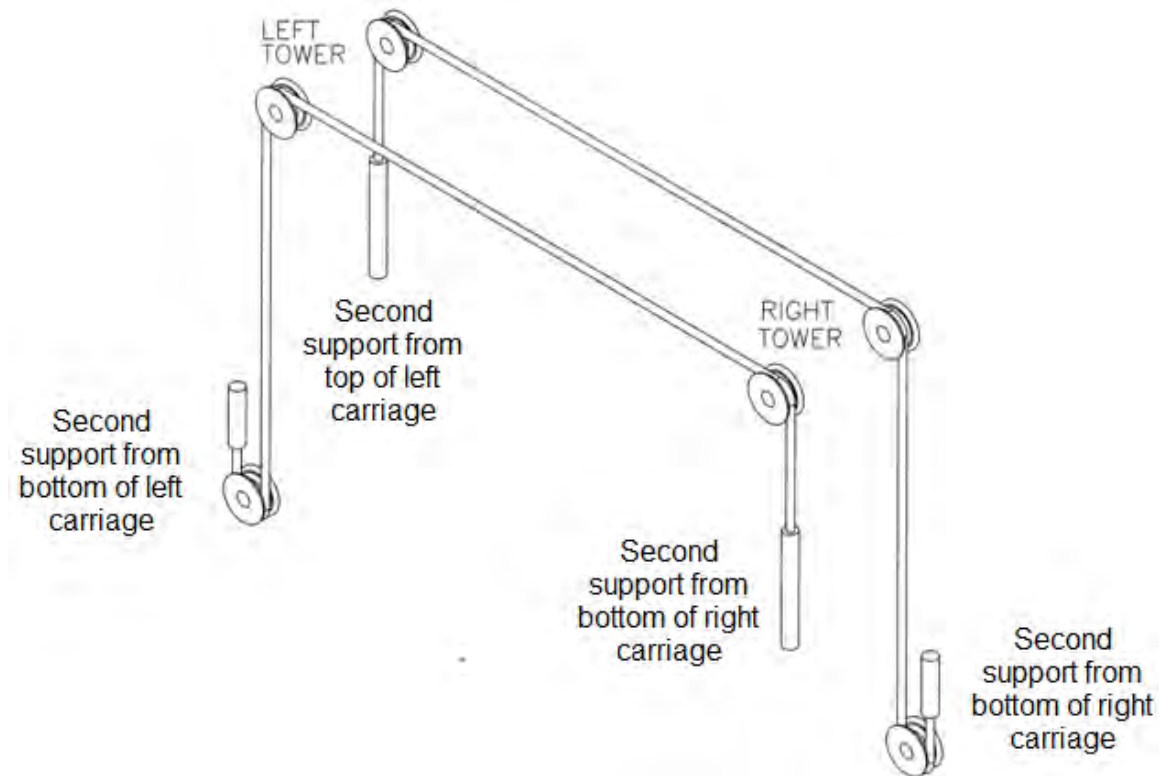

Figure 12: Cable Routing

4. Using the first cable, pass the short threaded stud, from the bottom of the carriage, through the $\frac{5}{8}$ " dia. hole in the lower mounting plate (**Figure 13**).
5. Feed the cable upwards until the stud comes through the top of the carriage. Thread the cable through the $\frac{5}{8}$ " dia. hole in the next mounting plate (**Figure 13**).
6. Thread a $\frac{1}{2}$ "-13UNC nut to the center of the stud, and then **firmly tighten** a second nut up against it using two wrenches. Pull the cable tight, through the bottom of the carriage.

7. At the bottom of the column, remove the hitch pin, pulley pin and pulley from the baseplate (**Figure 14**). Route equalizing cable around pulley and reassemble the pulley to the baseplate. **IMPORTANT – Hitch pin must be installed securely.**
8. Route the cable up through the slotted part of the mounting plate from the bottom of the carriage. When routing the cable through the carriage, the cable must be run through the slots in **ALL** cable mounting brackets.
9. Route the cable, around the upper pulley at the top of the column, across the crossmember, around the top pulley on the other column and then down into the opposite carriage. Ensure that the cable is routed through the cable retainers.
10. Insert the threaded stud into the 5/8" dia. hole in the mounting bracket second from the top of the carriage. (**Figure 13**).
11. Use a wrench to hold the top of the threaded stud to prevent it from rotating. Hand tighten (2) 1/2"-13 UNC nuts onto the threaded stud enough to remove all visible cable slack. Repeat steps 2 to 5 for the other equalizing cable.
12. Using a wrench to hold the top of the threaded stud, to prevent it from rotating, tighten the first nut approximately 1 1/2" past the hand tightened position. Then **firmly tighten** the second nut against the first one to lock it in place. Repeat for the other cable.

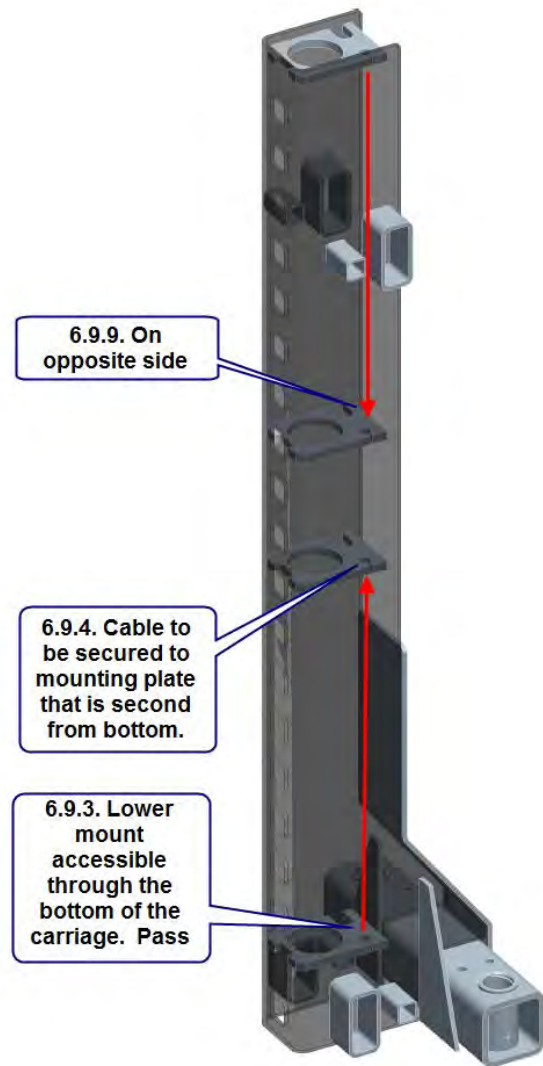

Figure 13: Cable Routing

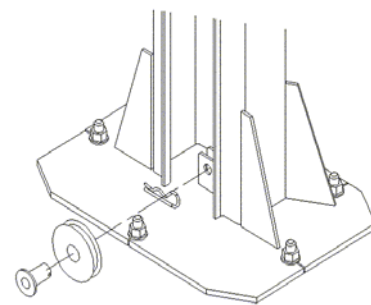

Figure 14: Pulley Assembly

7.10 ARM AND ARM RESTRAINT INSTALLATION

1. Remove the four (4) 5/16"-18UNC x 3/4"LG. hex head bolts that are holding the arm pins to the arm. Install the arms on the carriages.
2. Grease and insert arm pins. Align the notch on each arm pin with the tapped hole on the arm, and using the 5/16"-18UNC x 3/4"LG. hex head bolt removed in previous step, reinstall and tighten securely.



NOTE: Make sure the hex head bolts, 5/16" dia. x 3/4" lg. (6-0801), is lock tight into arms.

3. Insert arm restraint weldment through holes in carriage weldment. Arm restraints must pass through holes in top and bottom of carriage.
4. With carriage on the first safety position, slide the spring onto the arm restraint pin closer to the inside of the lift.
5. Insert roll pin to retaining the spring.
6. Repeat the above steps for remaining Arm Assemblies and Arm Restraints.

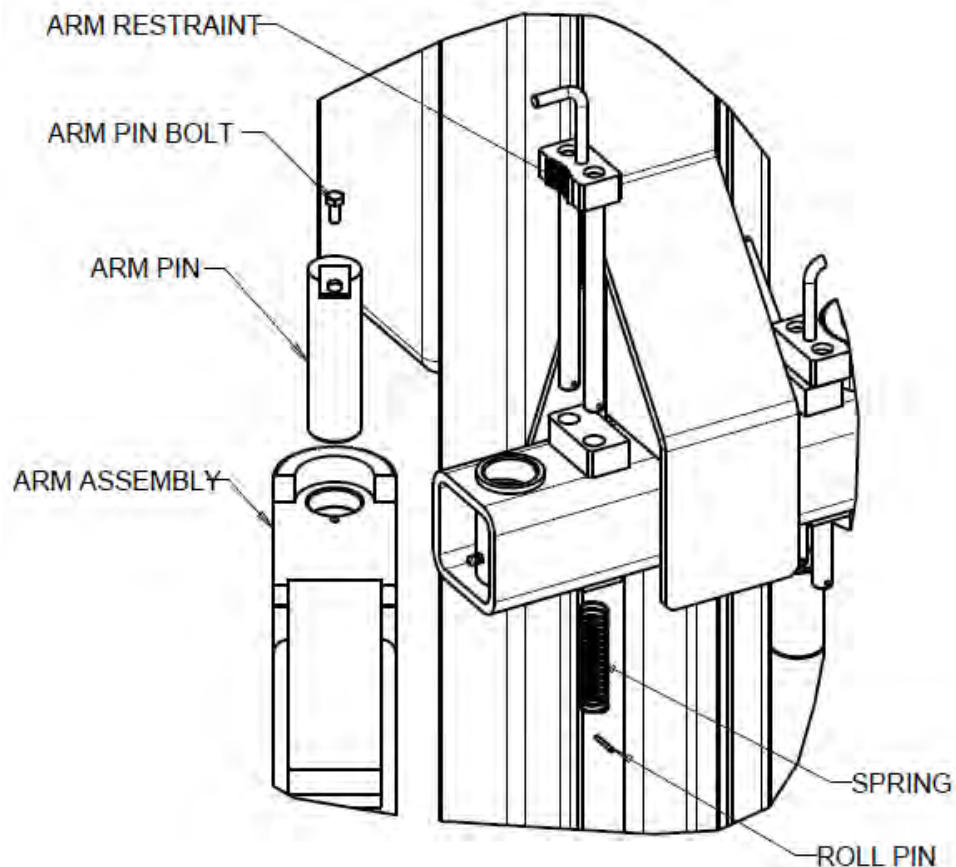

Figure 15 – Arm & Arm Restraint Installation

7.11 TOWER POSITIONING AND ANCHORING

WARNING! Failure to follow these instructions may cause an unsafe operating condition.

WARNING! Before proceeding with installation, review Section 6: Installation & Tools.

1. Prior to installing anchors, assemble the nut and washer onto anchors. A minimum of six threads must be visible below the surface of the nut.
2. Using a 4ft. level on top of the crossmember, determine which column is higher. Refer to **Figure 18**.
3. Using a 2ft. level on the sides of the high column, ensure that the column is level in the vertical position (**Figure 19**). Use shims under the column baseplate to hold the column level. Ensure that the base plate is completely supported by shims including near the center where it does not contact the floor (**Figure 20**).

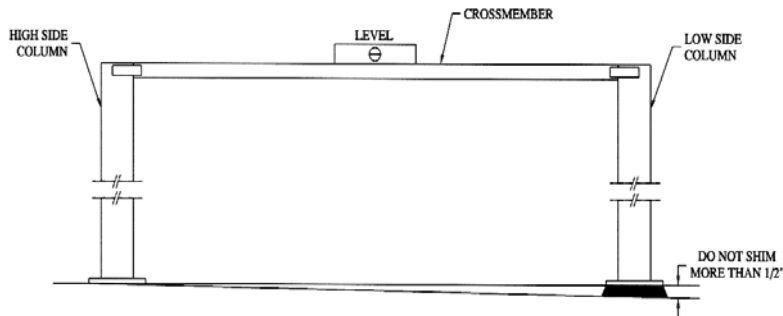

Figure 18

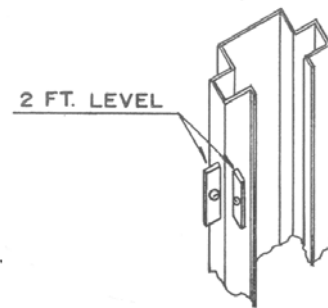

Figure 19

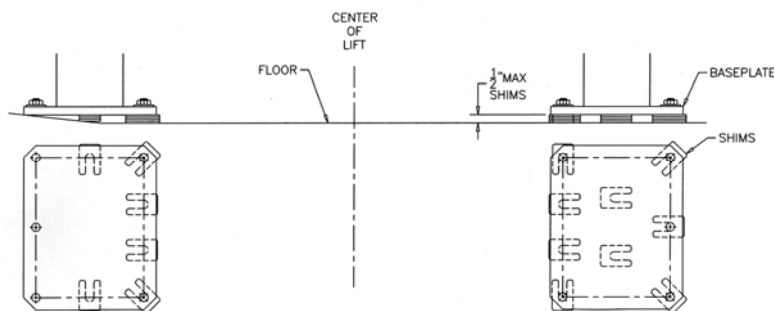

Figure 20 - Shims

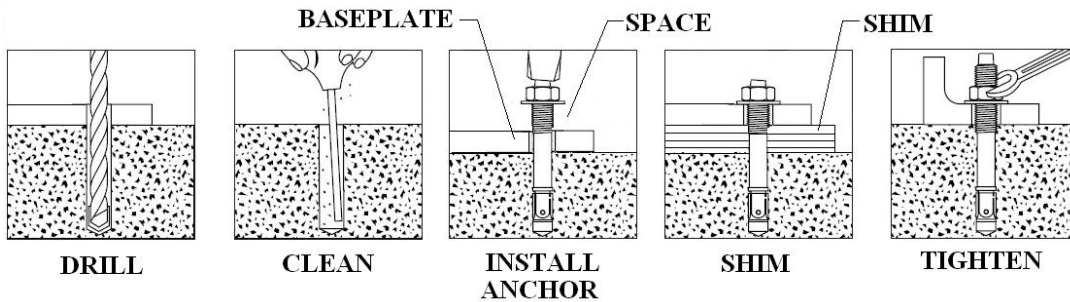
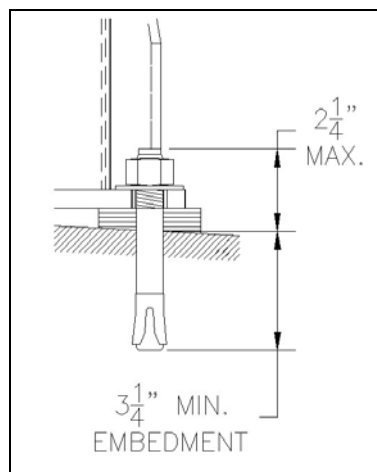

Figure 21 – Anchor Bolts

4. Refer to Bay Layout (**Figure 3**) to ensure that the column is still in the proper position. Using a rotary hammer drill with a 3/4" masonry drill bit and using the tower baseplate as a template, drill holes through the concrete floor on the high side column (In case longer anchors are required, supplied anchors can be hammered through concrete). Make sure that the 3/4" masonry drill is in good condition (**Figure 21**).
5. Carefully clean out drilling dust from the anchor holes. Hammer in the anchor bolts until they make contact with the baseplate (**Figure 21**). Hand tighten all anchor bolts.
6. Check the distance from the top of the anchor to the floor. If this dimension exceeds 2 1/4" due to floor slope, **DO NOT** use the supplied anchors. Longer anchor must be used (see #1 above).
7. Reconfirm that the column is level front to rear and side to side (**Figure 19**). Add or remove shims as required.



NOTE:
The 3/4" × 5 1/2" lg. wedge anchor bolts supplied must have a minimum embedment of 3 1/4" into concrete floor.

Figure 22. Anchor depth

8. Torque all anchor bolts to 150 ft-lbs. (203 Nm), continually checking that the column is level as you proceed. If anchor bolts do not tighten to 150 ft-lbs. OR project more than 2 1/4" above the concrete surface (**Figure 22**), the concrete should be replaced by an appropriate concrete pad. (*Consult Product Manufacturer / Supplier for further details*).

7.12 SHIMMING OF THE REMAINING TOWER

1. Using a 4ft. level on top of the crossmember (**Figure 18**) and a 2ft. level on the low side column (**Figure 19**), shim underneath the baseplate until the crossmember and column are level. Ensure that the baseplate is completely supported by shims including near the center where it does not contact the floor (**Figure 20**).
2. Refer to Bay Layout (**Figure 4**) to ensure that the column is still in the proper position. Using a rotary hammer drill with a 3/4" masonry drill bit and using the tower baseplate as a template, drill holes through the concrete floor on the low side column (In case longer anchors are required, supplied anchors can be hammered through concrete). Make sure that the 3/4" masonry drill is in good condition (**Figure 21**).
3. Carefully clean out drilling dust from the anchor holes. Hammer in the anchor bolts until they make contact with the baseplate (**Figure 21**). Hand tighten all anchor bolts.
4. Check the distance from the top of the anchor to the floor. If this dimension exceeds 2¼" due to floor slope, **DO NOT** use the supplied anchors. Longer anchor must be used.
5. Reconfirm that the column is level front to rear and side to side (**Figure 1**). Add or remove shims as required.
6. Torque all anchor bolts to 150 ft-lbs. (203 Nm), continually checking that the crossmember and column are level as you proceed. If anchor bolts do not tighten to 150 ft-lbs. OR project more than 2¼" above the concrete surface (**Figure 21**), the concrete should be replaced by an appropriate concrete pad. (*Consult Product Manufacturer / Supplier for further details*).
7. Verify that the entire lift is level both horizontally and vertically to ensure optimum lifting performance. **NOTE: Perform a monthly inspection and torque all anchor bolts to 150 ft-lbs. (203 Nm).**

8 FINAL CHECK OF ASSEMBLED LIFT

1. Final dimension check after anchoring	
2. Check for hydraulic leaks.	
3. Ensure cables are properly routed and free from obstructions.	
4. Check jam nuts on cables are tightened.	
5. Check that LOCTITE has been applied to all hardware where required.	
6. Check adjustment of safety release cable to ensure both sides	
7. working properly.	
8. Re-check level of towers.	
9. Check torque of anchor bolts.	
10. Check all fasteners, tighten if necessary.	
11. Check shut off at top of stroke to ensure lift shuts off.	
12. Check proper operation of arm restraints.	
13. Operate lift to full stroke then lower to ground while checking for proper functionality.	
14. Check proper operation of arm restraints.	
15. Ensure Customer Care Kit is complete and given to operator.	
16. Operation Manual	
17. ANSI / ALI Lift It Right Manual	
18. ANSI / ALI Safety Tip Card	
19. ANSI / ALI ALIS Safety Requirements for Installation	
20. ANSI / ALI Quick Reference Guide	
21. Train end user on operation of lift.	

9 OPERATING INSTRUCTIONS

1. Read and understand all safety and operation labels on the lift. Refer to the "**Lifting it Right**" manual and "**Safety Tips**" card supplied to you for additional important instructions and information.

NOTE: Some vehicles may have the manufacturer's Service Garage Lift Point locations identified by triangle shape marks on its undercarriage (reference SAE J2184). Also, there may be a label located on the right front door lock face showing specific vehicle lift points. If the specific vehicle lift points are not identified, refer to the "Typical Lift Points" figure below or the ANSI/ALI **Lift Point Guide** included with your lift.

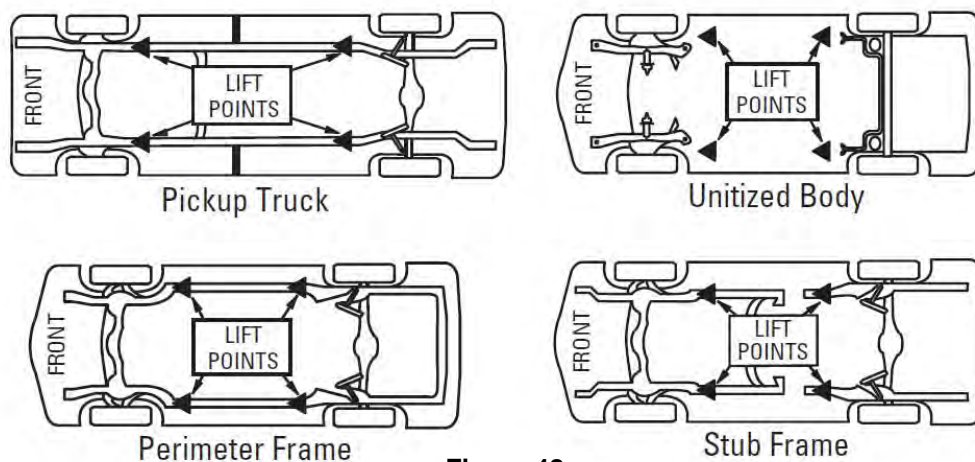
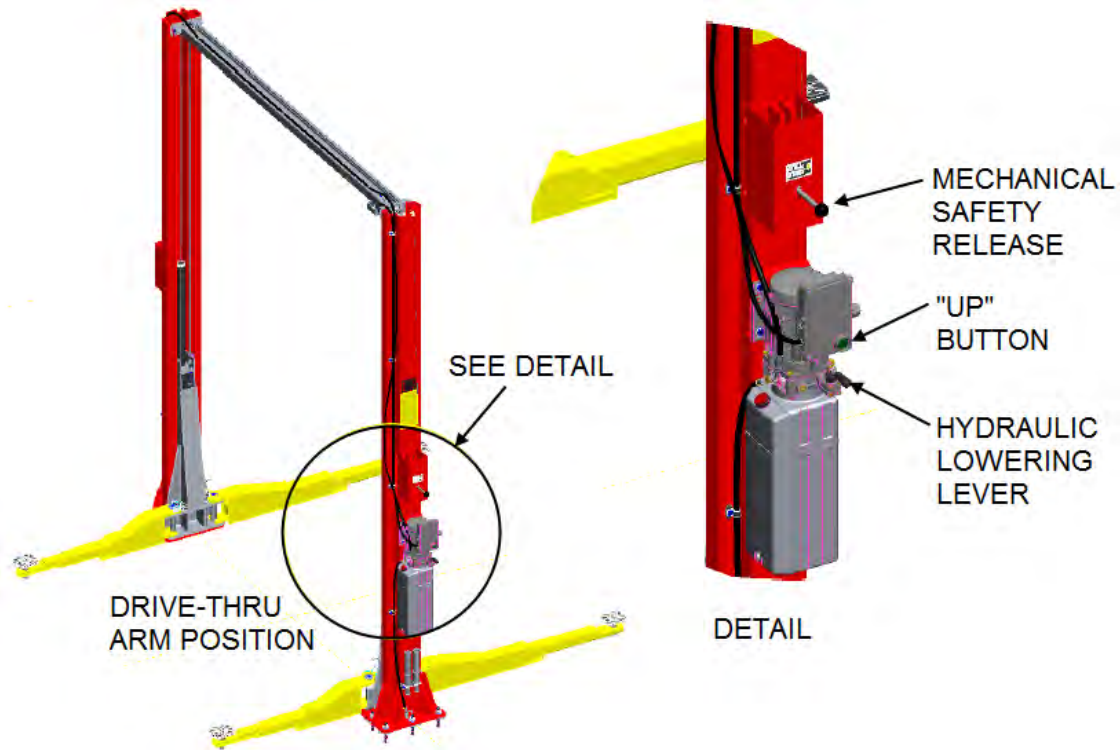

Figure 48

2. Position arms to drive-thru position (see figure 49).
3. Refer to supplied literature prior to loading vehicle. Center the vehicle between the lift post.
4. Only lift the vehicle on the manufacturers recommended lift points. Refer to supplied lift points guide (reference ANSI/SAE J2184-1992).
5. Locate lift pads on auto manufacturer's recommended lift points. Once you have correctly positioned the lift arms, ensure that all arm restraints are properly engaged.
6. Raise the vehicle by pushing the "UP" button on the powerpack until the vehicle's suspension has left the ground.
7. Inspect to make sure there are no interference with any objects and for proper engagement of the lifting pads.
8. Shake vehicle moderately by pushing on either the front or rear bumper. Visually inspect the lifting pads again. If the vehicle starts slipping on the lifting pads, or otherwise appears unstable on the lift, you have positioned the swing arms and adapters incorrectly. Carefully lower the lift and start over.

9. When satisfied, continue lift the vehicle to the desired working height, lower onto the mechanical safety using the lowering lever.
10. Once vehicle is ready to be removed, raise lift so that the mechanical safety can be released. Pull down and hold the mechanical safety release lever, then press the hydraulic lowering lever until the lift has fully collapsed to the grounds and the arm restraints are disengaged.
11. Swing the lift arms to the drive-thru position prior to moving the vehicle.



10 OPERATION TEST WITH VEHICLE

Prior to starting this section, please refer to Section 2 of this manual for important safety instructions.

1. Lower lift to ground.
2. Drive vehicle on to lift and locate the arms as per the "Lift it Right" manual.
3. Raise lift to and lower onto 3-4 lock positions during full rise to ensure all locks are working correctly.
4. Re-adjust cables if necessary while vehicle is on.
5. Check lowering speed and smooth decent rate.
6. Lower lift to ground and drive vehicle off lift.

If any problems occur during the final checkout or operation of the lift please contact customer service at 1-800-268-7959

11 LIFT MAINTENANCE GUIDLINES

11.1 SAFETY INSTRUCTIONS

Refer to Section 2 for more Safety Instructions.

1. Read operating and safety manuals before using any lift.
2. Do not operate a lift that has been damaged or is in disrepair.
3. Proper inspection and maintenance is necessary for safe operation.

11.2 PERIODIC MAINTENANCE BY OWNER/EMPLOYER

DAILY:

1. Check all hydraulic lines and fittings for pinch points, damage, cracks or leaks.
2. Check all electrical wiring for pinch points, cracks or damage.
3. Check all moving parts for uneven or excessive wear.
4. Repair or replace all damaged, defective, worn or broken components immediately.
5. Check the telescopic arms for movement. Clean any grease or oil from the lifting adapters.
6. Raise and lower the lift at the beginning of each shift, without a vehicle on, to verify the lift is leveled and operating properly.

EVERY TWO MONTHS:

1. Clean and re-grease slide block channels inside of both columns.
2. Grease arm pins.
3. Lubricate safety dogs and check safety release cable adjustment.
4. Check arm restraints and lubricate.
5. Check anchor bolts and re-torque if required.
6. Check Carriage Stop Block bolts for tightness.

EVERY FOUR MONTHS:

1. Dismantle and clean inner arms.
2. Lubricate cable pulleys.
3. Check equalizing cable adjustment.

EVERY YEAR:

1. Inspect lift as per Automotive Lift Operation, Inspection and Maintenance (ALOIM).

EVERY TWO YEARS:

1. Change hydraulic fluid.

LUBRICATION:

Where grease is required	>	multi-purpose lithium grease
Where lubricating oil is required	>	multi-purpose SAE 30 lubricating oil
Where hydraulic oil is required	>	ISO 32 10W - non detergent
hydraulic oil		

NOTE: If lift locks while in the fully raised position this will indicate that the hydraulic system has not been inspected or maintained as recommended. This is a safety back-up system. If you are unclear call your local representative immediately.

12 WIRE ROPES

⚠ WARNING

- Wire ropes are critical to safe and reliable performance of your lift.
- Cables are expendable items and should be replaced as a set.

12.1 WIRE ROPE CONDITION GUIDE

Typical good cable



Cable with necking



Broken wires

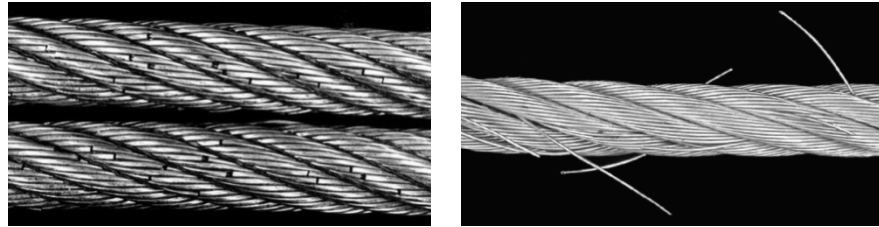

Excessive wear of wires

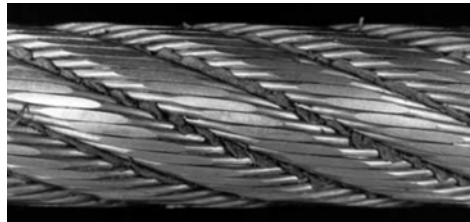

Rust on sheave stack and ropes



Corrugated sheave groove



(Pictures above are of a 4-Post Lift, conditions still apply to 2-Post Lifts)

12.2 WIRE ROPE REPLACEMENT CRITERIA:

⚠ WARNING

If any cable is found to be in need of replacement, the entire cable set, pulleys and safety rollers must be replaced immediately.

See 9.2.1, cable conditions guide.

In the following table, "lay" means the distance measured along a line parallel to the axis of the rope in which the strand makes one complete turn about the axis of the rope, or the wires make a complete turn about the axis of the strand.

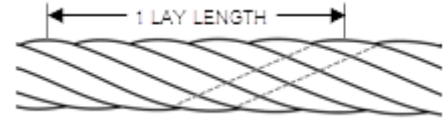

<i>The wire rope must be removed from service if one or more of the following criteria are met:</i>
1. More than six randomly distributed broken wires in one rope lay or 6×d length.
2. More than three broken wires in one strand in one rope lay or 6×d length.
3. Three or more broken wires at rope terminations.
4. One outer wire broken at the point of contact with the core of the rope which has worked its way out of the rope structure and protrudes or loops out from the rope structure
5. Heavy rusting, corrosion, or pitting. A light surface corrosion on outer wires is normal.
6. Wear or scraping of one-third of the original diameter of outside individual wires
7. Excessive stretch. It is normal for new cable to require adjustment during "break-in", after which small periodic adjustments may be required. However, if a cable that has been in service for 6 months should suddenly require frequent adjustments or has used all the cable adjustment available, all cables must be replaced immediately.
8. Deformed strands, kinking, crushing, bird-caging, or any other damage or distortion of wire rope structure
9. Variations in diameter (necking) or any change from normal appearance
10. Reductions from nominal diameter of more than 1/32" (for cables 3/8" to 1/2" dia. inclusive)
11. End attachments cracked, deformed or worn

12.3 WIRE ROPE INSPECTION

Inspect wire rope cables for wear or damage. Wipe cables with a rag to detect hard to see small broken or frayed cable strands. See chapter 9.2, Fig.75 and ANSI/ALI ALOIM standard.

12.4 WIRE ROPE LUBRICATION

Lubricate wire ropes with lift in both lowered and raised position, by spraying them with wire rope lubricant (i.e. 2001 MONOLEC®) and wiping the cable down.

14 TROUBLESHOOTING GUIDE

PROBLEM	REASON	SOLUTION
Power Pack (Motor) not running.	Bad Fuse or Circuit breaker.	Replace bad fuse or reset circuit breaker.
	Incorrect voltage to motor.	Provide proper voltage to motor.
	Improper wiring.	Have certified electrician check wiring.
	Power Pack up switch not functioning.	Replace Power Pack up switch.
	Overhead Microswitch not functioning.	Replace overhead Microswitch.
	Power Pack motor burned out.	Replace motor.
Power Pack (Motor) runs but lift does not go up.	Low oil level.	Fill reservoir with proper hydraulic oil.
	Oil valve remains open.	Repair or replace oil valve.
	Pump sucking air.	Tighten all fittings and suction lines.
Lift goes up slowly or oil coming out from filler cap.	Air in hydraulic fluid lines	Bleed hydraulic lines (Call installer).
Lift doesn't come down.	Dirt in directional valve	Call installer to clean valve. (Do not attempt to open hydraulic lines unless vehicle is secure)
Safety Dog does not engage.	Safety Dog jammed.	Oil or replace pin to free Safety Dog. Check or replace spring.
Safety Dog does not disengage.	Safety dog is being limited	Check for any obstructions.
Lift goes up unlevel.	Equalizing cables are loose.	Adjust equalizing cables to correct tension.
	Floor unlevel.	Shim lift to make towers level. (Do not exceed 1/2" of shimming).
Lift goes up with chatter or does not fully rise.	Low oil level.	Fill reservoir to correct level with proper hydraulic oil.
	Air in hydraulic fluid lines/cylinder.	Bleed hydraulic lines. (Call installer).
Anchor bolts do not stay tight.	Holes are too large.	Relocate lift using proper size drill bit.
	Incorrect concrete floor specification (Thickness and holding strength).	Break existing floor and pour new pad for lift.
Noticeable Deflection of Arm or arm dragging on floor.	Lift out of plumb.	Plumb columns.
	Unlevel floor.	Replace floor or shim columns.
	Worn arm or carriage holes.	Replace parts.
	Worn carriage slide blocks.	Replace side blocks.
	Bent arm (Overloaded).	Replace arm. Also check damage to carriage.

15 LOCK OUT AND TAG OUT INSTRUCTIONS

IMPORTANT: This machine does not have integral devices that will isolate the electrical, pneumatic, stored and hydraulic energy source. Appropriate isolation or blocking devices must be used that have the provisions to be switched in the off position and locked in that position.

ALL MAINTANANCE AND SERVICE MUST BE PERFORMED BY A QUALIFIED PERSON.

ALL MAINTANANCE AND SERVICE MUST BE PERFORMED WITH THE LIFT UNLOADED.

IT IS THE SHOP OWNERS RESPONSIBILITY TO ENSURE ENERGY ISOLATING DEVICES ARE:

- Accessible
- Conveniently located to facilitate the application of lockout devices during service and maintenance
- Located outside any hazardous area.
- At a convenient manipulating height (i.e. not overhead, on ladders or under machinery)
- Adequately labeled or marked. Identification shall include machine ID, energy type and magnitude.
- Capable of being locked or otherwise secured in an effective isolating position.

Effective hazardous energy control procedures will protect employees during machine and equipment servicing and maintenance where the unexpected energization, start up or release of stored energy could occur and cause injury, as well as while working on or near exposed de-energized electrical conductors and parts of electrical equipment. Hazards being guard against include being caught in, being crushed by, being struck by, being thrown from, or contacting live electrical circuits/parts.

In preparation for lockout, an initial survey must be made to locate and identify all energy isolating devices to be certain which switch, valve, or other energy isolating devices apply to the machine / equipment to be locked out. More than one energy source (electrical, hydraulic, pneumatic, or others) may be involved.

SHUT DOWN PROCEDURE:

- Notify all affected employees that a lockout or tagout system is going to be utilized and the reason for. The authorized employee shall know the type and magnitude of energy that the lift utilizes and shall understand the associated hazards.

- **ELECTRICAL:** Located at the user control panel, press the “E-STOP” button to disconnect the raise and lower functions.

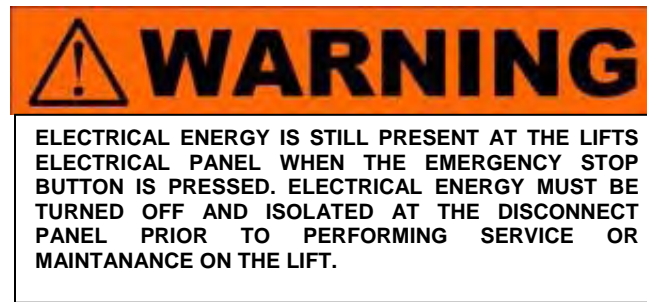

15.1 ISOLATION AND VERIFICAITON PROCEDURES:

Table 1: ISOLATION AND VERIFICATION PROCEDURES:

ENERGY TYPE AND SOURCE	LOCKOUT LOCATION (TO BE COMPLETED BY END USER)	PROCEDURE FOR LOCING OUT AND OR RELEASING ENERGIES	VERIFY PROCEDURES
<p>STORED ENERGY</p> <p>AND</p> <p>HYDRAULIC PRESSURE 3000-5000 PSI</p>		<p>LOWER THE LIFT TO ITS LOWEST REST POSTION. IF THE LIFT MUST BE SERVICED OR MAINTAINED IN THE RAISED POSITION, ENSURE THAT THE LIFT IS PLACED ON THE MECHANICAL LOCKS.</p> <p>FOR SCISSOR LIFTS, ADDITIONAL SUPPORT WITH SUPPLEMENTARY JACK STANDS, BLOCK AT THE SLIDERS AND A COME ALONG SECURED BETWEEN THE SCISSORS.</p> <p>FOR 4-POST LIFTS, ADDITIONAL SUPPORT WITH SUPPLEMENTARY JACK STANDS.</p>	<p>VERIFY THAT THE LIFT IS (IF APPLICABLE):</p> <p>CONTACTING THE MECHANICAL LOCKS,</p> <p>RESTING ON THE SUPPLEMENTARY JACK STANDS,</p> <p>BLOCKS ARE SECURLY PLACED</p> <p>COME ALONG IS SECURED BETWEEN THE SCISSORS.</p>

<p>ELECTRICAL 240VOLTS</p>		<p>AT THE LIFT, PRESS THE EMERGENCY STOP BUTTON COMPLETELY TO DE-ENERGIZE THE CONTROL BUTTONS (IF APPLICABLE).</p> <p>AT THE DISCONNECT PLANEL, PLACE THE DISCONNECT HANDLE IN OFF POSITION. ATTACH A MULTIPLE LOCOUT DEVICE. LOCK AND TAG.</p> <p><u>DANGER: LINE SIDE OF DISCONNECT REMAINS ENERGIZED</u></p>	<p>ATEMPT TO RESTART THE SYSTEM, THE SYSTEM MUST NOT START. VISUALLY VERIFY OPEN DISCONNECTS AND LOCKING DEVICE INSTALLED.</p>
<p>PNEUMATIC UPTO 160PSI</p>		<p>SLOWLY CLOSE LOCKOUT VALVE TO RELEASE AIR PRESSURE GRADUALLY. ATTACH MULTIPLE LOCKOUT DEVICE, LOCK AND TAG.</p> <p><u>DANGER: LINE SIDE OF DISCONNECT REMAINS PRESSURIZED</u></p>	<p>VERIFY THE VALVE IS CLOSED AND LOCKOUT DEVICE IS PROPERLY ATTACHED. OPERATE THE PNEUMATIC SYSTEM TO ENSURE THE SYSTEM IS DE-ENERGIZED. IT MAY BE NECESSARY TO BLEED THE SYSTEM OF REMAINING COMPRESSED AIR, THIS CAN BE PERFORMED AT THE BASE OF THE WATER SEPARATOR BOWL.</p>

15.2 RETURNING TO SERVICE:

- Check the lift and the immediate area around the lift to ensure that nonessential items,, tools and parts are removed and that the lift components are operationally intact.
- Check the work area to ensure that all employees have been safely positioned or removed from the work area.
- Notify all employees that the lockout/tagout is going to be removed and the lift is going to restarted.
- Remove the lockout/tagouts in the reverse order as the installation.
- Verify the proper operation of the equipment.
- Notify affected employees that the maintenance/service is completed and the machine is ready for operation.

16 EMERGENCY OPERATION:

If the lift becomes inoperative in the raised position, it is best to wait until the electrical power is restored before lowering the vehicle. However, if it's critical to safety that the lift be lowered, the following steps should be taken.



WARNING: DO NOT LOOSEN OR REMOVE HYDRAULIC CONNECTIONS OR FITTINGS UNDER PRESSURE. SERIOUS INJURY OR DEATH COULD OCCUR.

NOTE: Safely performing this process requires 3 people. All personnel should stay clear of the path of the lift. All tools and other non-secured items should be removed from the surface of the ruways.

- 1) Survey the area surrounding the lift; remove any items and personnel from area before proceeding with this procedure.
- 2) Perform the appropriate lockout/tag out procedure on the electrical energy.
- 3) Use a second person standing at a safe distance away from the lift to keep watch on the area, lift, vehicle and other personnel throughout the process. This person should signal the person performing the procedure to stop if necessary.
- 4) Use a caution tape or similar to barrier the area around the lift to avoid personnel from accidentally entering the area while this process is being performed.
- 5) Do not proceed with this procedure if you are unfamiliar with the lift or its function.

16.1 IF THE MECHANICAL LOCKS ARE NOT ENGAGED:

- 1) Pull safety release lever simultaneously pressing the descent lever on the powerpack.
- 2) Keep a close eye on the movement of the lift and the position of the vehicle; release descent lever if any abnormal movement is detected.
- 3) Continue until the lift is fully lowered.
- 4) Once power is restored follow the lockout/tag out procedure to return the lift back into service.

16.2 IF THE MECHANICAL LOCKS ARE ENGAGED:

Various methods can be used to raise the lift in order to get sufficient clearance to disengage the mechanical locks. The safest method would employ temporary electrical power to the lift using a portable power generator. Any electrical connections should be done by a licensed electrician; lockout/tag out procedures should also be employed at this time.

This process should only be performed by a trained professional. Contact customer service or a local service professional for further assistance.

17 PARTS MANUAL

17.1 LIFT ASSEMBLY

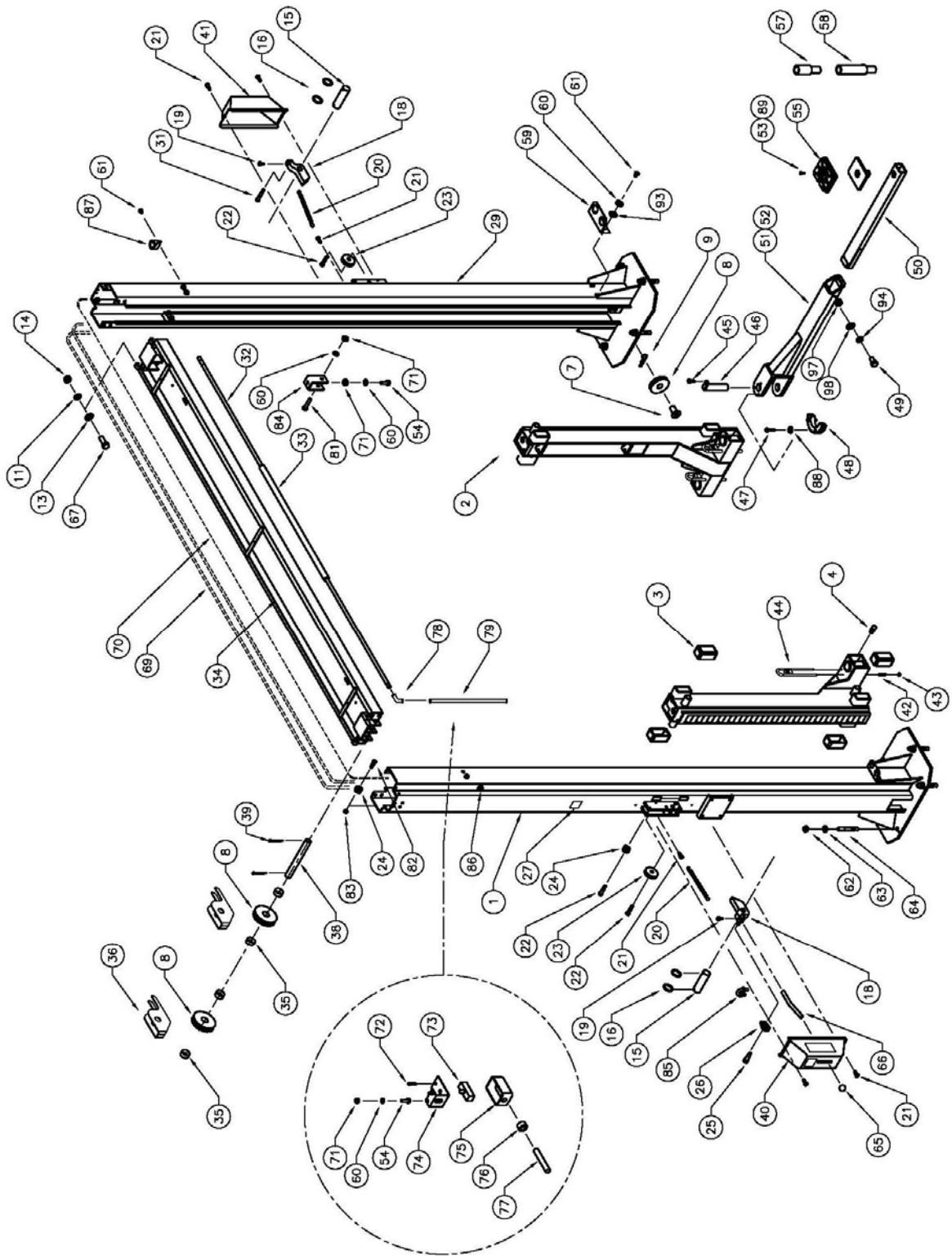

REPLACE WORN, DAMAGED OR BROKEN PARTS WITH PARTS APPROVED BY THE ORIGINAL EQUIPMENT MANUFACTURER ONLY

17.2 LIFT ASSEMBLY PARTS LIST

ITEM	QTY	DESCRIPTION	PART #
1	1	TOWER WELDMENT, POWER SIDE	4-1199
2	2	CARRIAGE WELDMENT	4-1170
3	8	GLIDE BEARING	2-0772
4	4	GREASE NIPPLE	6-0000
7	2	PIN, CABLE EQUALIZATION	1-1887
8	6	2-POST PULLEY	1-1898
9	2	HITCH PIN, 1/8" DIA	6-1841
11	8	LOCKWASHER, 1/2"ID	6-0059
13	8	FLAT WASHER, 1/2"ID SAE	6-0248
14	16	HEX NUT, 1/2"-13UNC	6-0035
15	2	SAFETY PIN	1-2337
16	4	SNAP RING 3/4" EXT	6-2445
18	2	SAFETY DOG WELDMENT, POWER SIDE	2-1901
19	2	MACHINE SCREW, #8 X 1" LG.	6-3965
20	2	SAFETY SPRING	1-1115
21	6	SELF TAPPING SCREW, #12 x 1/2"LG.	6-1134
22	3	SHOULDER BOLT, 3/8"DIA. x 1"LG.	6-0206
23	2	SAFETY PULLEY	1-0415
24	3	SAFETY CABLE PULLEY	1-1116
25	1	SHOULDER BOLT, 3/8" X 1 1/2" LG.	6-0801
26	1	THIMBLE, 5/32"	6-2074
27	1	CAPACITY DECAL	6-1764
29	1	TOWER WELDMENT, SLAVE SIDE	4-1200
31	1	SHOULDER BOLT, 3/8"DIA. x 1 1/2"LG.	6-0801
32	1	ACTUATOR BAR	1-1439
33	1	FOAM GUARD	6-1404
34	1	CROSSMEMBER WELDMENT	2-2042
35	8	CROSSMEMBER PULLEY PIPE, 1/2"LG.	1-1623
36	2	CABLE RETAINER	1-3493
38	2	CROSSMEMBER PULLEY SHAFT	1-2669
39	4	COTTER PIN, 1/8" X 1 1/2" LG.	6-0978
40	1	SAFETY COVER cw/DECALS, POWER SIDE	0-0204
41	1	SAFETY COVER cw/DECALS, SLAVE SIDE	0-0203
42	4	ARM LOCK SPRING	1-2942
43	4	SPRING RETAINER CAP	6-3086
44	4	LOCK HANDLE WELDMENT	1-2914
45	4	HEX BOLT, 5/16"-18UNC x 3/4" LG.	6-0423
46	4	ARM PIN	2-2032
47	8	HEX BOLT, 5/16"-18UNC x 1 1/4" LG.	6-2059
48	4	ARM RESTRAINT GEAR	1-2618
49	4	HEX BOLT, 3/8"-UNC x 3/4" LG.	6-0030
50	4	INNER ARM WELDMENT	2-2940

ITEM	QTY	DESCRIPTION	PART #
51	4	OUTER ARM WELDMENT	3-1117
52	4	LOCKING ARM ASSEMBLY (incl. arm pin)	4-1365
53	4	STACK PAD ASSEMBLY	1-3278
54	1	HEX BOLT, 1/4"-20UNC x 3/4" LG.	6-0008
55	4	RUBBER PAD	3-0872
57	4	STACK PAD ADAPTER, 3"	1-3280
58	4	STACK PAD ADAPTER, 6"	2-1580
59	2	STACK PAD ADAPTER HOLDER	1-2012
60	10	LOCKWASHER, 1/4" ID	6-0056
61	10	ROUND HEAD SCREW, 1/4"-20UNC x 3/8" LG.	6-1353
62	10	HEX NUT, 3/4"-10UNC	6-0737
63	10	FLAT WASHER, 3/4"ID	6-0738
64	10	WEDGE ANCHOR, 3/4"-10UNC x 5 1/2"LG.	6-1379
65	1	PLASTIC KNOB	6-1135
66	1	SAFETY RELEASE HANDLE	1-1113
67	8	HEX BOLT, 1/2"-13UNC x 1 1/4" LG.	6-0291
69	2	EQUALIZING CABLE	1-3288
70	1	SAFETY RELEASE CABLE	1-2058
71	7	HEX HD. NUT 1/4"NC	6-0032
72	2	6/32 SCREW (ELECTRICAL BOX)	6-1466
73	1	MICROSWITCH	6-0916
74	1	LIMIT SWITCH MTG. BRACKET	2-1143
75	1	ELECTRICAL UTILITY BOX	6-1403
76	1	CABLE CONNECTOR	6-1133
77	1	ELEC. CABLE 12/3, 11-3/4 FT (12FT MODEL)	8-0030
78	1	ACTUATOR EXTENSION	1-3553
79	1	90° ELBOW, 1/2" CONDUIT	6-2889
81	1	HEX HD. BOLT 1/4"NC x 1 1/2"LG.	6-0205
82	2	SHOULDER BOLT, 3/8"DIA. x 5/8"LG.	6-0069
83	2	HEX NUT, 5/16"-18UNC	6-0294
84	1	ACTUATOR MTG. BRACKET	1-1378
85	2	WIRE ROPE CLIP, 1/16"	6-2060
86	3	ELECTRICAL CABLE CLIP, 5/8" ID	6-1759
87	6	TUBE CLAMP, 1/2"	6-1547
88	8	FLATWASHER, 5/16"	6-0295
89	4	ALLEN HEX HD SCREW 1/4"	6-1086
93	4	1/4" FLAT WASHER SAE	6-0060
94	4	LOCKWASHER 3/8" ID	6-0058
95	2	HEX BOLT, 1/4"-20UNC x 1" LG.	6-0008
96	4	CABLE RETAINER	1-3493
97	4	LOCKNUT	6-3369
98	4	FLAT WASHER	6-0062

17.3 HYDRAULIC SYSTEM

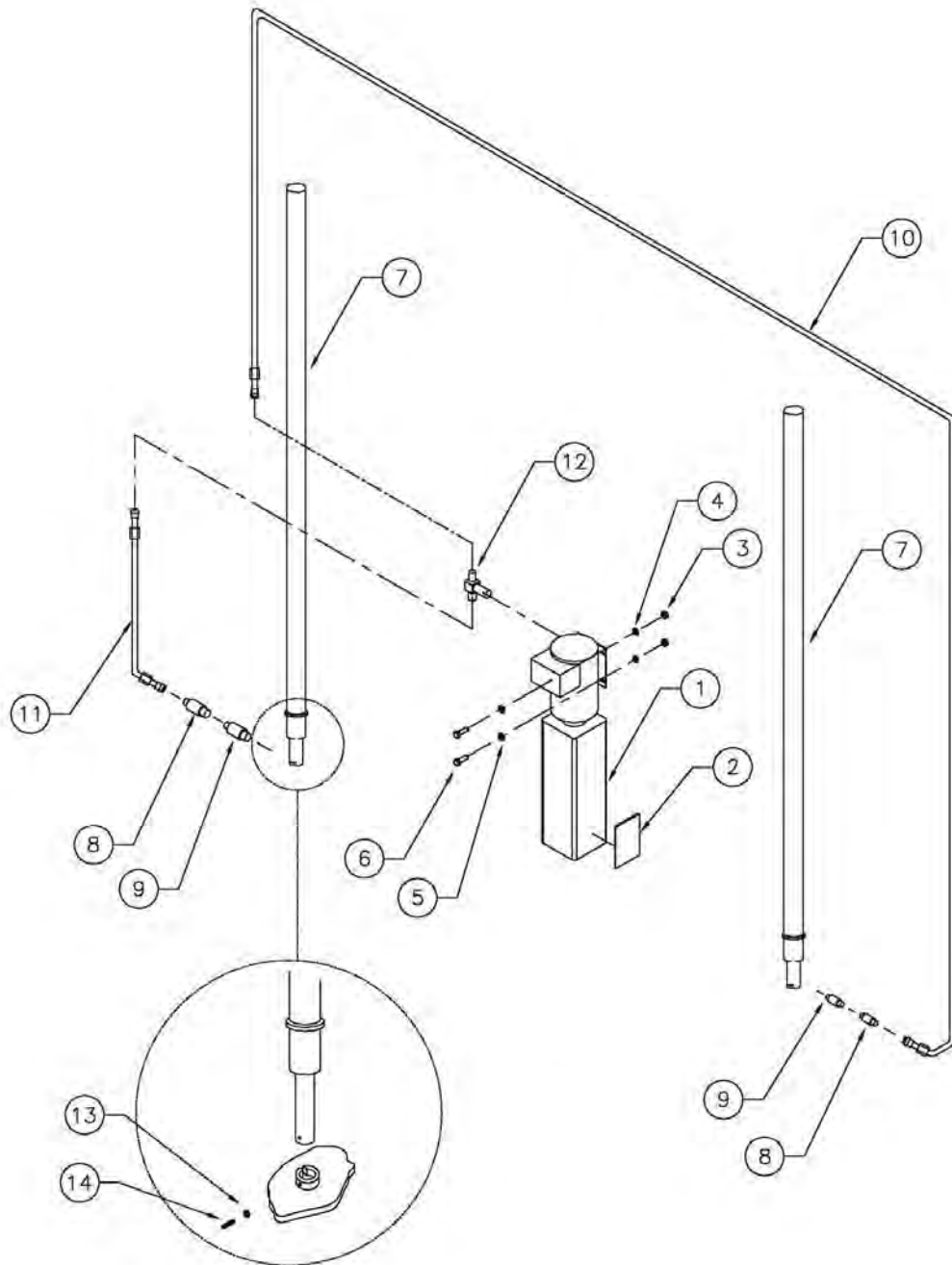

17.4 HYDRAULIC SYSTEM PARTS LIST

ITEM	QTY	DESCRIPTION	PART #
1	1	POWER PACK, 220V/1PH	6-3647
2	1	"LIFT OPERATION" DECAL	6-3039
3	4	HEX NUT, 5/16"-18UNC	6-0294
4	4	LOCK WASHER, 5/16" I.D.	6-0674
5	4	FLAT WASHER, 5/16" I.D.	6-0295
6	4	HEX BOLT, 5/16"-18UNCx1" LG.	6-0293
7	2	CYLINDER ASSEMBLY	2-2272
8	2	FLOW CONTROL	6-3781
9	2	MALE NIPPLE	6-2095
10	2	HYDRAULIC HOSE (LONG)	1-2714
11	2	HYDRAULIC HOSE (SHORT)	2-1230
12	1	BRANCH "T"	6-1506
13	2	HEX NUT 3/8"-16 UNC	6-3119
14	2	SET SCREW 3/8"-16 x 1" "FULL DOG" PT	6-3285
	*	SEAL KIT	6-3395

17.5 POWER PACK:

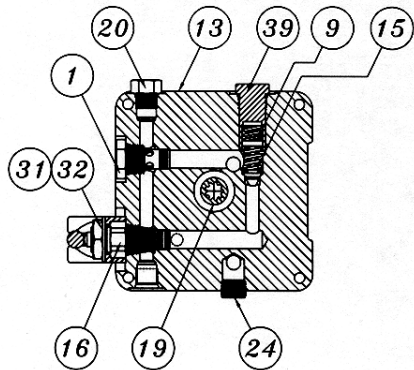
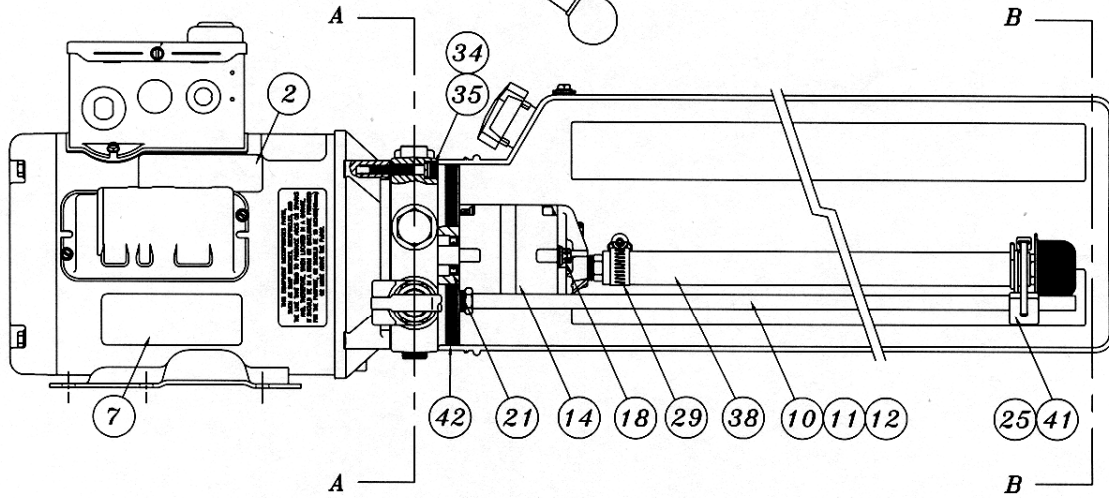
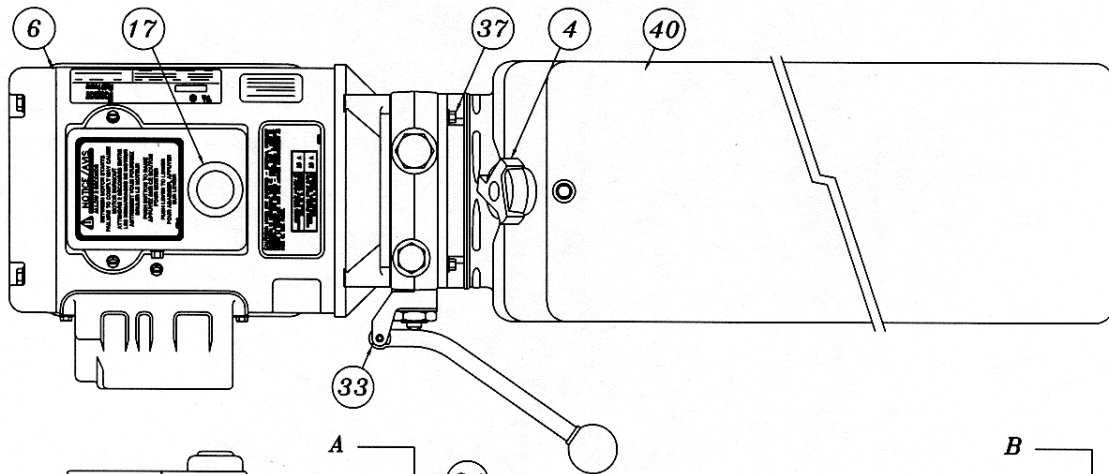

A-A

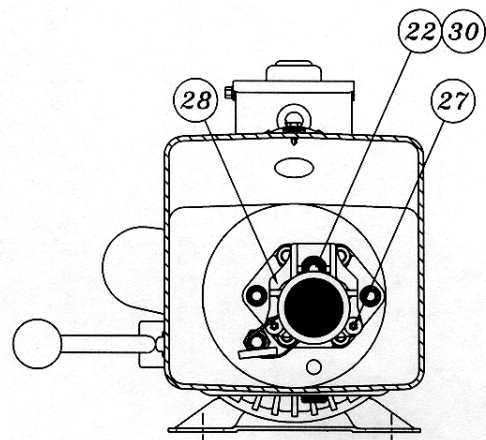

B-B

17.6 POWER PACK PARTS LIST:

#6-3647 (AB-6748) 208-230V/1PH/60Hz

ITEM	QTY.	DESCRIPTION	PART #
1	1	VALVE CARTRIDGE CHECK	6-1087
2	1	LABEL INSTALLATION AUTOHOIST	6-2136
4	1	BREATHER CAP & BLADDER	6-1376
6	1	MOTOR, ELEC 208-230V 60Hz/1PH/2HP 3450RPM	6-3699
7	1	LABEL WARNING AUTOHOIST	6-2149
9	1	SPRING 0.480" x 0.063" x 0.42" COMP	6-2151
10	1	RETURN HOSE 3/8" OD x 21.5"	6-3700
11	1	COMPRESSION TUBE NUT	6-2153
12	1	COMPRESSION TUBE SLEEVE	6-2154
13	1	ENDHEAD UNIVERSAL AUTOHOIST	6-3701
14	1	PUMPASSY 2.5 CC/REV. SHORT SPLINE	6-3702
15	1	RELIEF ASSEMBLY FIXED 120 BAR	6-3703
16	1	VALVE CARTRIDGE RELEASE MANUAL	6-0880
17	1	WIRING ASSEMBLY AC 1PH FENNER	6-2473
18	2	BOLT 5/16"-24 x 3.00" TORX G8	6-3704
19	1	COUPLING SAE 9T-20/40 1.260"	6-0774
20	1	PLUMBING PLUG 9/16" SAE	6-2157
21	1	SEAL SHAFT 0.500" x 1.00" x 0.25"	6-2158
22	1	WASHER 0.338" x 0.625" x 0.060" STEEL	6-2159
24	1	PLUMBING PLUG 3/8" NPT	6-2161
25	1	PLUMBING MAGNET	6-2162
27	2	SCREW TAPTITE M6 x 1.0 12MM TORX	6-2164
28	1	COVER ASSY SUCTION	6-2165
29	1	PLUMBING CLAMP HOSE ADJ. INLET	6-2166
30	1	BOLT 5/16"-18 x 1.00" SHCS	6-1392
31	1	NUT 3/4"-16 x 1" HEX x 0.250" STEEL	6-2167
32	1	WASHER 3/4" INT. TOOTH LOCK	6-2168
33	1	BRACKET – HANDLE ASSY REL BLACK	6-3705
34	4	BOLT M6 x 1.0 35MM SOC HD	6-2169
35	4	WASHER 1/4" LOCK HI-COLLAR	6-2170
37	4	BOLT #12-24 x 0.50' HEX WSHRHD	6-1091
38	1	PLUMBING ASSY INLET 17.24 (3)	6-3706
39	1	RELIEF VALVE CAP ASSEMBLY	6-1089
40	1	TANK PLASTIC 4.0 GAL 26.0" WHITE	6-4175
41	1	CABLE TIE 8" LONG WHITE	6-1846
42	1	O-RING 2-348 BUNA	6-0875

18 AVAILABLE ACCESSORIES

Flip Pad Accessories				
	Poly Pad Adapter (set of 4)		High Lift Truck Extension Mid-Rise / 2-Post (set of 2)	
3000 lb max capacity each		3000 lb max capacity each		
Stack Pad Accessories				
	Stack Pad Adapter w/ Checker Plate Top (set of 4)		Stack Pad Ass'y w/ 3" & 6" Adapters (set of 1)	
3000 lb max capacity each		3000 lb max capacity each		
	1 1/2" Stack Pad Assembly Kit		4 1/2" Stack Adapter Kit	
3000 lb max capacity each		3000 lb max capacity each		
Common Accessories				
	Tool Tray Kit for 2-Post		Secondary Adapter Pad Kit (Used On Outer Arms)	
		3000 lb max capacity each		
	Air / Electric Service Station for 2-Post & 4-Post (90-110 psi 110 Volts Required)		Foam Door Protector Kit	
				24" Tower Extension

Accessories may not be available for all models. Contact supplier for availability and part numbers.

Max capacity is for 12,000 Lb Lifts. Do not exceed rated capacity of lift.