

HOFMANN

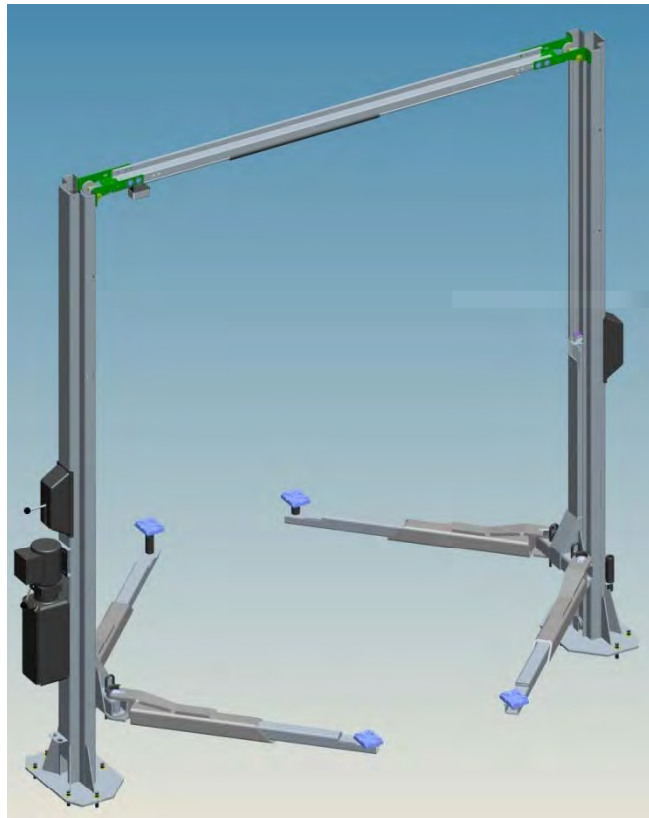

INSTALLATION and OPERATION MANUAL



10K 2 POST DUOLIFT V-SERIES DLSA10V

**READ THIS INSTRUCTION MANUAL THOROUGHLY BEFORE
INSTALLING, OPERATING, SERVICING OR MAINTAINING THE
LIFT. SAVE THIS MANUAL.**



309 Exchange Avenue • Conway, AR 72032
(800) 251-4500 • (501) 505-2662
Fax (501) 450-2085 • www.hofmann-usa.com



6500 Millcreek Drive • Mississauga, ONT L5N 2W6
(800) 267-2185
Fax (905) 821-2073 • www.hofmann.ca

MAY 2013 REV. - 6-3857

Table of Contents

1.0 OWNER / EMPLOYER OBLIGATIONS	4
2.0 IMPORTANT SAFETY INSTRUCTIONS.....	5
3.0 SAFETY AWARENESS	8
4.0 SPECIFICATIONS.....	9
5.0 PACKING LIST.....	10
5.1 MAIN STRUCTURAL COMPONENTS	10
5.2 ACCESSORY BOX.....	10
6.0 INSTALLATION REQUIREMENTS AND TOOLS.....	11
6.1 FOUNDATION	11
6.2 TOOLS.....	11
7.0 INSTALLATION INSTRUCTIONS.....	12
7.1 UNPACKING PROCEDURE.....	12
7.2 BAY LAYOUT	13
7.3 CROSSMEMBER INSTALLATION	14
7.4 SAFETY SHUT-OFF BAR INSTALLATION	16
7.5 ROUTING OF EQUALIZATION CABLE.....	18
7.6 ARM INSTALLATION.....	21
7.7 SAFETY RELEASE CABLE ROUTING AND ADJUSTMENT	22
7.8 POWER PACK INSTALLATION	24
7.9 HYDRAULIC SYSTEM INSTALLATION	25
7.10 HYDRAULIC SYSTEM BLEEDING	28
7.11 TOWER POSITIONING AND ANCHORING.....	29
7.12 POSITION AND ANCHORING OF REMAINING TOWER.....	31
7.13 SAFETY SHUT-OFF BAR ADJUSTMENT	34
8.0 FINAL CHECK OF ASSEMBLED LIFT.....	35
9.0 OPERATING INSTRUCTIONS.....	35
9.1 OPERATION TEST WITH VEHICLE	37
10.0 MAINTENANCE GUIDELINES.....	38
10.1 SAFETY INSTRUCTIONS	38
10.2 PERIODIC MAINTENANCE.....	38
11.0 WIRE ROPES	39
11.1 WIRE ROPE CONDITION GUIDE	39
11.2 WIRE ROPE REPLACEMENT CRITERIA:.....	40
11.3 WIRE ROPE INSPECTION	40
11.4 WIRE ROPE LUBRICATION	41

11.5 WIRE ROPE ADJUSTMENT	41
12.0 Maintenance Schedule	42
13.0 troubleshooting GUIDE	43
14.0 LOCK OUT AND TAG OUT INSTRUCTIONS.....	44
14.1 SHUT DOWN PROCEDURE:	44
14.2 ISOLATION AND VERIFICAITON PROCEDURES:	45
14.3 RETURNING TO SERVICE:	46
15.0 EMERGENCY OPERATION:	47
15.1 IF THE MECHANICAL LOCKS ARE NOT ENGAGED:	47
15.2 IF THE MECHANICAL LOCKS ARE ENGAGED:.....	47
16.0 Parts List	48
16.1 HYDRAULIC SYSTEM:	52
16.2 POWER PACK PARTS LIST:.....	54
17.0 Available Accessories	56

1.0 OWNER / EMPLOYER OBLIGATIONS

1. The Owner/Employer shall ensure that lift operators are qualified and that they are trained in the safe use and operation of the lift using the manufacturer's operating instructions; ALI/SM 93-1, **ALI Lifting it Right safety manual**; ALI/ST-90 **ALI Safety Tips card**; ANSI/ALI ALOIM-2008, **American National Standard for Automotive Lifts - Safety Requirements for Operation, Inspection and Maintenance**; **ALI/WL Series, ALI Uniform Warning Label Decals/Placards**; and in the case of frame engaging lifts, ALI/LP-GUIDE, **Vehicle Lifting Points/Quick Reference Guide for Frame Engaging Lifts**.
2. The Owner/Employer shall establish procedures to periodically inspect the lift in accordance with the lift manufacturer's instructions or ANSI/ALI ALOIM-2008, **American National Standard for Automotive Lifts - Safety Requirements for Operation, Inspection and Maintenance**; and the Employer shall ensure that the lift inspectors are qualified and that they are adequately trained in the inspection of the lift.
3. The Owner/Employer shall establish procedures to periodically maintain the lift in accordance with the lift manufacturer's instructions or ANSI/ALI ALOIM-2008, **American National Standard for Automotive Lifts - Safety Requirements for Operation, Inspection and Maintenance**; and the Employer shall ensure that the lift maintenance personnel are qualified and that they are adequately trained in the maintenance of the lift.
4. The Owner/Employer shall maintain the periodic inspection and maintenance records recommended by the lift manufacturer's instructions or ANSI/ALI ALOIM-2008, **American National Standard for Automotive Lifts - Safety Requirements for Operation, Inspection and Maintenance**.
5. The Owner/Employer shall display the lift manufacturer's operating instructions; ALI/SM 93-1, **ALI Lifting it Right safety manual**; ALI/ST-90 **ALI Safety Tips card**; ANSI/ALI ALOIM-2008, **American National Standard for Automotive Lifts - Safety Requirements for Operation, Inspection and Maintenance**; **ALI/WL Series, ALI Uniform Warning Label Decals/Placards**; and in the case of frame engaging lifts, ALI/LP-GUIDE, **Vehicle Lifting Points/Quick Reference Guide for Frame Engaging Lifts** in a conspicuous location in the lift area convenient to the operator.
6. The Owner/Operator shall provide necessary lockout/tagout means for energy sources per ANSI Z244.1-1982 (R1993), **Safety Requirements for the Lockout/Tagout of Energy Sources**, before beginning any lift repairs and maintenance.

7. The Owner/Employer shall not modify the lift in any manner without the prior written consent of the manufacturer.

2.0 IMPORTANT SAFETY INSTRUCTIONS

- 1. When using this lift, basic safety precautions should always be followed, including the following:**
2. Read all instructions in this manual and on the lift thoroughly before installing, operating, servicing or maintaining the lift.
3. Care must be taken as burns can occur from touching hot parts.
4. Do not operate equipment with a damaged cord or if the equipment has been dropped or damaged – until it has been examined by a qualified service person.
5. Do not let a cord hang over the edge of the table, bench, or counter or come in contact with hot manifolds or moving fan blades.
6. If an extension cord is necessary, a cord with a current rating equal to or more than that of the equipment should be used. Cords rated for less current than the equipment may overheat. Care should be taken to arrange the cord so that it will not be tripped over or pulled.
7. Always unplug equipment from electrical outlet when not in use. Never use the cord to pull the plug from the outlet. Grasp plug and pull to disconnect.
8. Let equipment cool completely before putting away. Loop cord loosely around equipment when storing.
9. To reduce the risk of fire, do not operate equipment in the vicinity of open containers of flammable liquids (gasoline).
10. Adequate ventilation should be provided when working on operating internal combustion engines.
11. Keep hair, loose clothing, fingers, and all parts of body away from moving parts.
12. To reduce the risk of electric shock, do not use on wet surfaces or expose to rain.

13. Use only as described in this manual. Use only manufacturer's recommended attachments.
14. **ALWAYS WEAR SAFETY GLASSES.** Everyday eyeglasses only have impact resistant lenses, they are not safety glasses.
15. Inspect lift daily. Do not operate if it malfunctions or problems have been encountered.
16. Never attempt to overload the lift. The manufacturer's rated capacity is shown on the identification label on the power side column. Do not override the operating controls or the warranty will be void.
17. Before driving vehicle between the towers, position the arms to the drive-through position to ensure unobstructed clearance. Do not hit or run over arms as this could damage the lift and/or vehicle.
18. Only trained and authorized personnel should operate the lift. Do not allow customers or bystanders to operate the lift or be in the lift area.
19. Position the lift support pads to contact the vehicle manufacturers recommended lifting points. Raise the lift until the pads contact the vehicle. Check pads for secure contact with the vehicle. Check all arm restraints and insure they are properly engaged. Raise the lift to the desired working height.
20. Some pickup trucks may require an optional truck adapter to clear running boards or other accessories.
21. **NOTE:** Always use all 4 arms to raise and support vehicle.
22. **Caution!** Never work under the lift unless the mechanical safety locks are engaged.
23. Note that the removal or installation of some vehicle parts may cause a critical load shift in the center of gravity and may cause the vehicle to become unstable. Refer to the vehicle manufacturer's service manual for recommended procedures.
24. Always keep the lift area free of obstruction and debris. Grease and oil spills should always be cleaned up immediately.
25. Never raise vehicle with passengers inside.
26. Before lowering check area for any obstructions.

27. Before removing the vehicle from the lift area, position the arms to the drive-thru position to prevent damage to the lift and /or vehicle.

28. Do not remove hydraulic fittings while under pressure.

For additional safety instructions regarding lifting, lift types, warning labels, preparing to lift, vehicle spotting, vehicle lifting, maintaining load stability, emergency procedures, vehicle lowering, lift limitations, lift maintenance, good shop practices, installation, operator training and owner/employer responsibilities, please refer to “Lifting It Right” (ALI/SM) and “Safety Tips” (ALI/ST) and vehicle lift points for service garage lifting SAE J2184.

For additional instruction on general requirements for lift operation, please refer to “Automotive Lift-Safety Requirements For Operation, Inspection and Maintenance” (ANSI/ALI ALOIM).

Installation shall be performed in accordance with ANSO/ALI ALIS, Safety Requirements for Installation and Service of Automotive Lifts.



ATTENTION! This lift is intended for indoor installation only. It is prohibited to install this product outdoors. Operating environment temperature range should be 41 – 104 °F (5 – 40 °C). **Failure to adhere will result in decertification, loss of warranty, and possible damage to the equipment.**

+ 070726-Quadra-WLSIA01

SAFETY INSTRUCTIONS

If attachments, accessories or configuration modifying components that are located in the load path, affect operation of the lift, affect the lift electrical listing or affect intended vehicle accommodation are used on this lift and, if they are not certified for use on this lift, then the certification of this lift shall become null and void. Contact the participant for information pertaining to certified attachments, accessories or configuration modifying components.

www.autolift.org

©2007 by ALI, Inc.











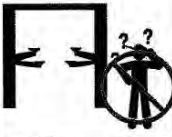

ALI / WLSIA01

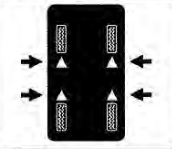
3.0 SAFETY AWARENESS

REFERENCE: AUTOMOTIVE LIFT INSTITUTE (ALI)

Automotive Lift Institute, Inc WL101 Series Label Kit

<p>NOTICE</p>  <p>Read operating and safety manuals before using lift.</p>	<p>NOTICE</p>  <p>Proper maintenance and inspection is necessary for safe operation.</p>
<p>NOTICE</p>  <p>Do not operate a damaged lift.</p>	<p>The messages and pictographs shown are generic in nature and are meant to generally represent hazards common to all automotive lifts regardless of specific style.</p> <p>Funding for the development and validation of these labels was provided by the Automotive Lift Institute, PO Box 85 Cortland, NY 13045.</p> <p>Replacement label sets may be obtained from the original lift manufacturer and ALI's member companies. They are protected by copyright.</p> <p>www.autolift.org © 2009 by ALI, Inc. ALI/WL101s</p>

<p>CAUTION</p>  <p>Lift to be used by trained operator only.</p>	<p>CAUTION</p>  <p>Authorized personnel only in lift area.</p>	<p>WARNING</p>  <p>Clear area if vehicle is in danger of falling.</p>	<p>WARNING</p>  <p>Position vehicle with center of gravity midway between adapters.</p>
<p>CAUTION</p>  <p>Use vehicle manufacturer's lift points.</p>	<p>CAUTION</p>  <p>Always use safety stands when removing or installing heavy components.</p>	<p>WARNING</p>  <p>Remain clear of lift when raising or lowering vehicle.</p>	<p>WARNING</p>  <p>Avoid excessive rocking of vehicle while on lift.</p>
<p>CAUTION</p>  <p>Use height extenders when necessary to ensure good contact.</p>	<p>CAUTION</p>  <p>Auxiliary adapters may reduce load capacity.</p>	<p>WARNING</p>  <p>Do not override self-closing lift controls.</p>	<p>WARNING</p>  <p>Keep feet clear of lift while lowering.</p>
<p>The messages and pictographs shown are generic in nature and are meant to generally represent hazards common to all automotive lifts regardless of specific style.</p> <p>Funding for the development and validation of these labels was provided by the Automotive Lift Institute, PO Box 85 Cortland, NY 13045.</p> <p>Replacement label sets may be obtained from the original lift manufacturer and ALI's member companies. They are protected by copyright.</p> <p>www.autolift.org © 2009 by ALI, Inc. ALI/WL101c</p>		<p>The messages and pictographs shown are generic in nature and are meant to generally represent hazards common to all automotive lifts regardless of specific style.</p> <p>Funding for the development and validation of these labels was provided by the Automotive Lift Institute, PO Box 85 Cortland, NY 13045.</p> <p>Replacement label sets may be obtained from the original lift manufacturer and ALI's member companies. They are protected by copyright.</p> <p>www.autolift.org © 2009 by ALI, Inc. ALI/WL101e</p>	

SAVE THESE INSTRUCTIONS

Note: Some images in this manual are generic and may not resemble the lift you have purchased.

4.0 SPECIFICATIONS

Capacity:
 Capacity per arm:
 Overall Width:
 Width Between Columns:
 Drive-Thru Width:
 Overall Height:
 Under bar Clearance:
 Height to Lowered Lift Pads
 Height to Lift Pad (3" Adapter):
 Height to Lift Pad (6" Adapter):
 Front Arm Retracted Length:
 Front Arm Extended Length:
 Rear Arm Retracted Length:
 Rear Arm Extended Length:
 Maximum Lifting Height (6" Adspecapter):
 Lift Time:
 Power Requirements (Standard):

 Maximum Operating Pressure @ Rated Load:

10000 lbs.	4536 kg
2500 lbs	1134 kg
135"	3429 mm
110"	2794 mm
88"	2235 mm
144"	3658 mm
140"	3556 mm
4 1/2"	114 mm
7 1/2"	191 mm
10 1/2"	267 mm
22 1/2"	572 mm
45 1/2"	1158 mm
38"	965 mm
59 1/2"	1511 mm
79 1/4"	2013 mm
45 seconds	
230 Volts AC, 1 Ph., 60 Hz. 20 Amps	
2680 psi	

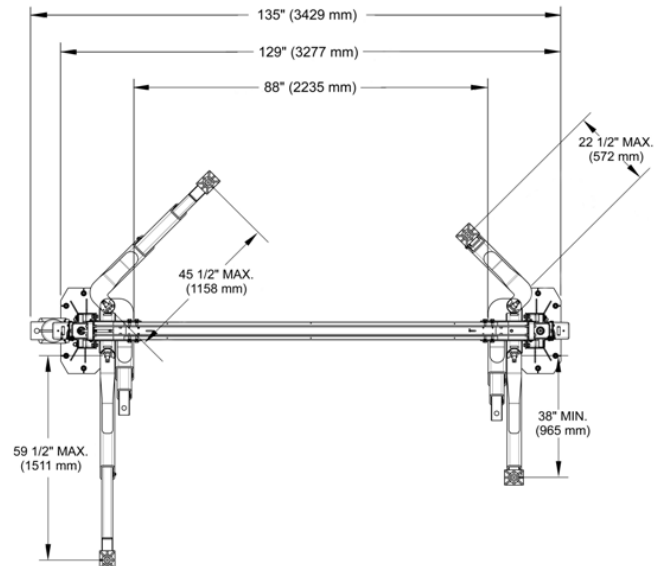
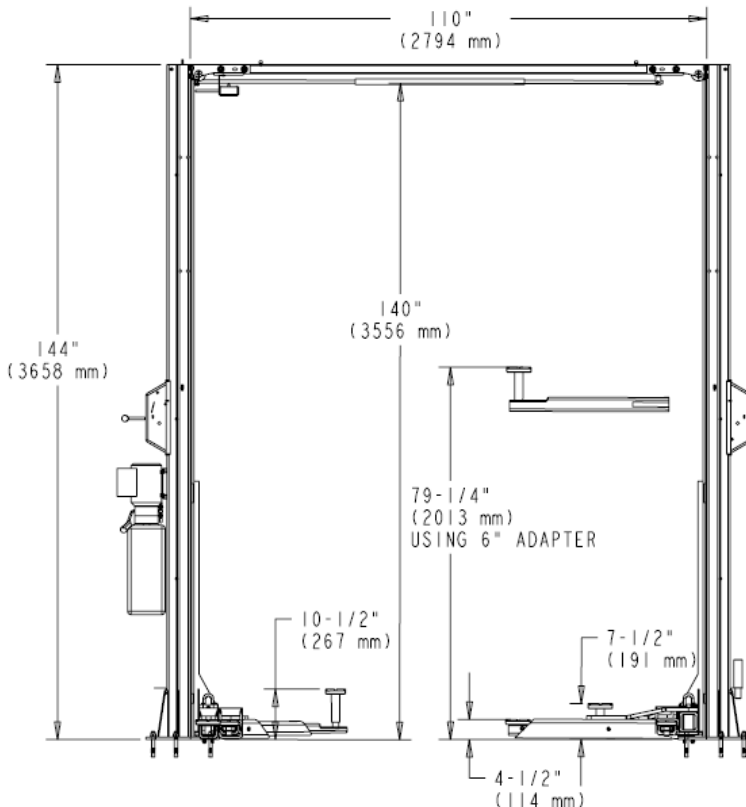

5.0 PACKING LIST

The complete lift is contained in two (2) packages:

1. The **main structural components** are packed in a steel frame.
2. The remaining parts are packed in an **accessory box**.

5.1 MAIN STRUCTURAL COMPONENTS

- 1pc. - Power side tower and carriage assembly
- 1pc. - Slave side tower and carriage assembly
- 1pc. - Crossmember
- 1pc. - Actuator Bar w/ foam

5.2 ACCESSORY BOX

- 4pcs. - Locking Arm Assembly w/arm pins
- 2pcs. - Safety Covers w/Decals
- 1pc. - Hardware Package w/Packing List
- 1pc. - Actuator Extension
- 1pc. - Actuator Mounting Bracket
- 1pc. - Power Pack
- 4pc. - Arm Restraint
- 1pc. - Safety Release Cable
- 1pc. - Hydraulic Hose (Long)
- 1pc. - Hydraulic Hose (Short)
- 2pcs. - Equalizing Cable w/Hex Nuts
- 1pc. - ALI manual "Lifting It Right"
- 1pc. - Automotive Lift Safety Tips
- 1pc. - Automotive Lift, Operation, Inspection and Maintenance manual
- 1pc. - "ALI" Quick Reference Guide
- 1pc. - Owner's manual
- 1pc. - Safety Shut-off Microswitch Assembly (Components)

6.0 INSTALLATION REQUIREMENTS AND TOOLS

6.1 FOUNDATION

IMPORTANT: It is the user's responsibility to provide a satisfactory installation area for the lift. Lifts should only be installed on level concrete floors with a minimum thickness of six inches (6") or 152 mm. Concrete must have a minimum strength of 4000 psi or 28 MPa and should be aged thirty (30) days prior to installation. Please consult the architect, contractor or engineer if doubt exists as to the strength and feasibility of the floor to enable proper lift installation and operation.

A qualified person should be consulted to address seismic loads and other local or state requirements.

It is the user's responsibility to provide all wiring for electrical hook-up prior to installation and to insure that the electrical installation conforms to local building codes. Where required, it is the user's responsibility to provide an electrical isolation switch located in close proximity to the lift that will enable emergency stop capability and isolate electrical power from the lift for any servicing requirements.

6.2 TOOLS

- a. 16ft. Measuring Tape
- b. Chalk Line
- c. Rotary Hammer Drill
- d. 3/4" diameter Masonry Drill Bit
- e. Hammer
- f. SAE Wrenches and Ratchet Set
- g. 2ft. Level
- h. 4ft. Level
- i. Crow Bar
- j. 12ft. Step Ladder
- k. Side Cutters
- l. Screwdrivers
- m. 4" x 4" Wooden Blocks (for unpacking)
- n. Wherever LOCTITE symbol is shown, apply LOCTITE #242 on required fasteners. If fasteners are removed reapply LOCTITE before re-installing.



7.0 INSTALLATION INSTRUCTIONS

When the lift arrives on site:

- Read the owner's manual and make sure the installation instructions are fully understood.
- Check for any freight damages.
- Check the contents of the accessory and hardware boxes to make sure no parts are missing.
- Gather all the tools listed above.

7.1 UNPACKING PROCEDURE

- 5.1.1 Important! Place the main structural components on wooden blocks so that the steel shipping frames can be removed.
- 5.1.2 Remove the plastic wrapping.
- 5.1.3 Remove the crossmember, and the actuator bar.
- 5.1.4 Unbolt the steel shipping frames.
- 5.1.5 Lay each tower on the floor with the carriage side up.
- 5.1.6 Check the installation area for obstructions. (Lights, Heating Ducts, Ceiling, Floor Drains, etc.)

7.2 BAY LAYOUT

- 5.2.1 Prepare the bay by selecting the location of the lift relative to the walls.
- 5.2.2 Clear the installation area of all packaging materials to avoid trip hazards.
- 5.2.3 Measure midpoint of door.
- 5.2.4 Using measuring tape scribe two arcs, equal distance from the midpoint.
- 5.2.5 The centerline of the lift occurs between the intersection of the arcs and the midpoint of the door.

Note: Leave any additional room for any desired aisle or work area. Recommended minimum clearance around lift is three feet (3 ft) and above lift is four inches (4"). Ensure clearance conforms to local building and fire codes.

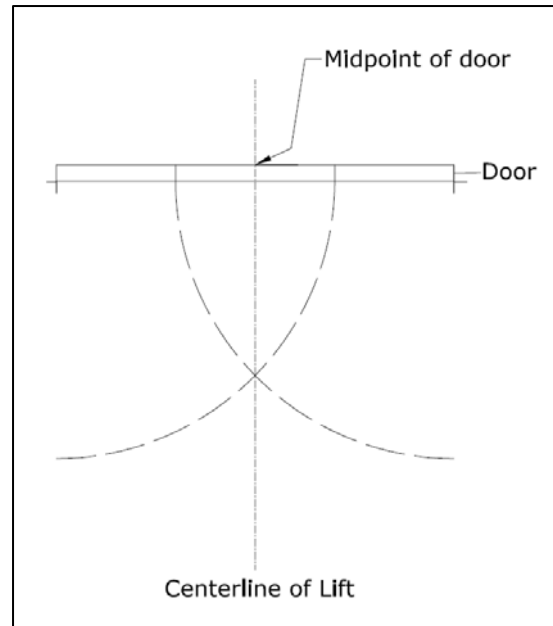

Figure 3. Chalk line

- 5.2.6 Measure the specified distance (126") to draw a second chalk line at 90° for locating the lift towers. Refer to Figure 3.
- 5.2.7 The lift is centered between the door and the walls of the area.

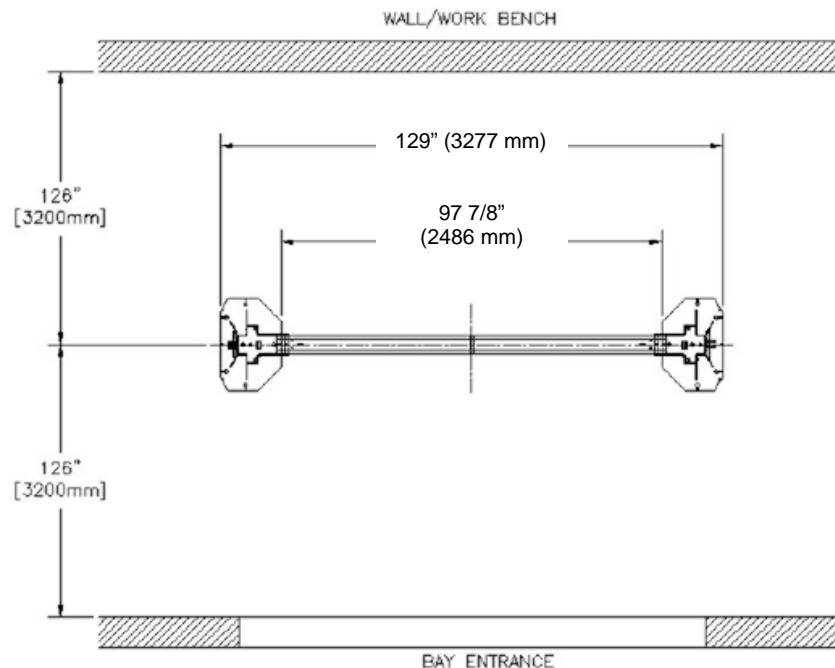
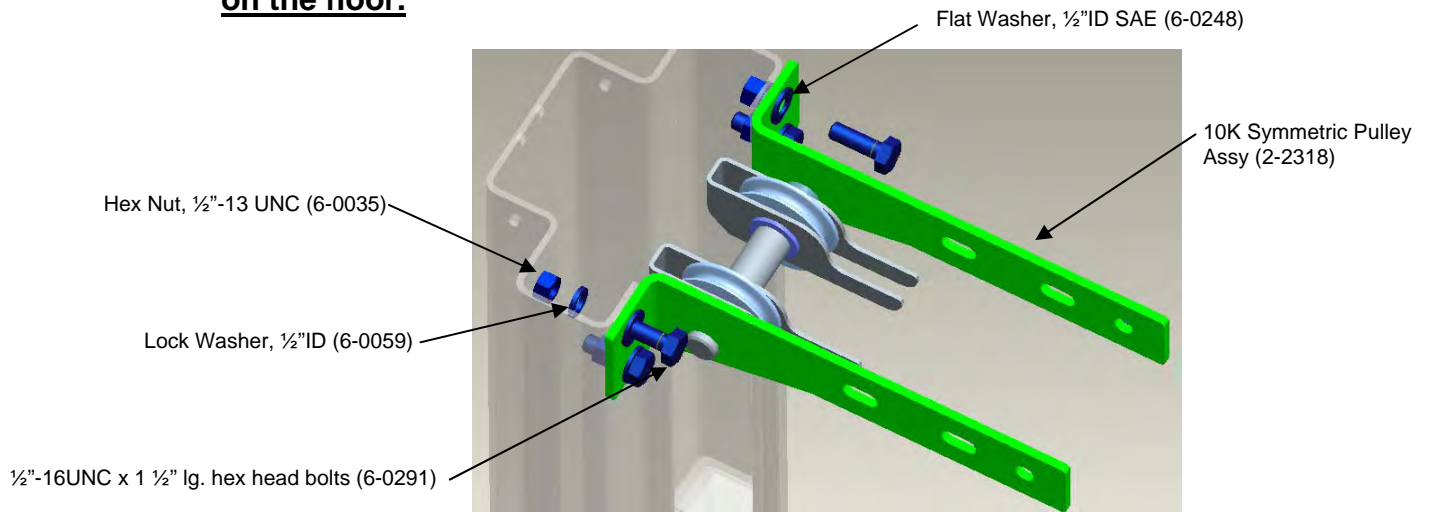

Figure 4. Bay Layout

7.3 CROSSMEMBER INSTALLATION

5.3.1 Install the cross member bracket to the two towers. **While they are still on the floor.**



5.3.2 Stand towers in the position shown.

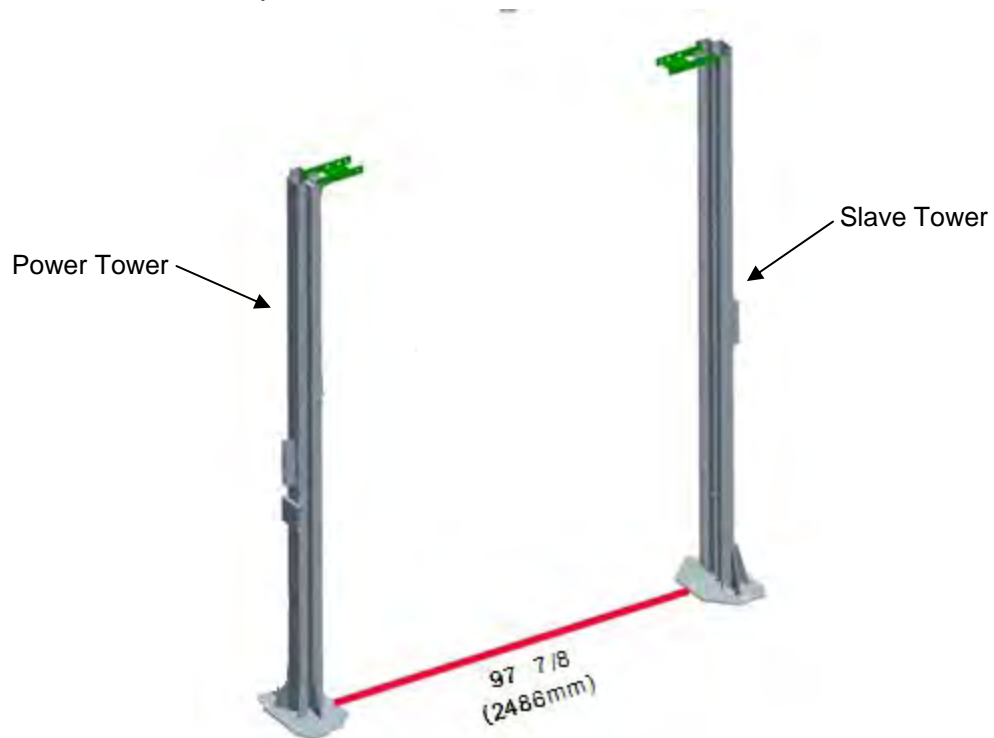

5.3.3 Using a stepladder, insert screwdrivers into brackets and place crossmember on top of screwdrivers.

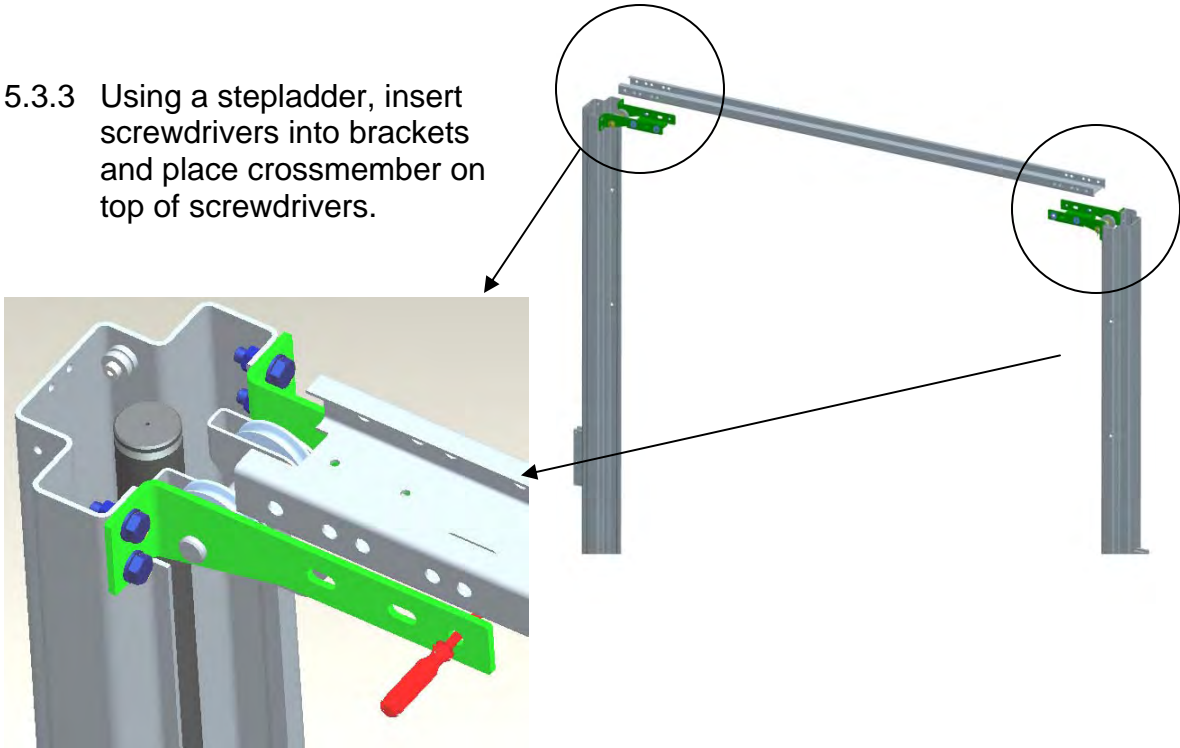

5.3.4 Locate crossmember to the correct holes in the bracket and install fasteners.

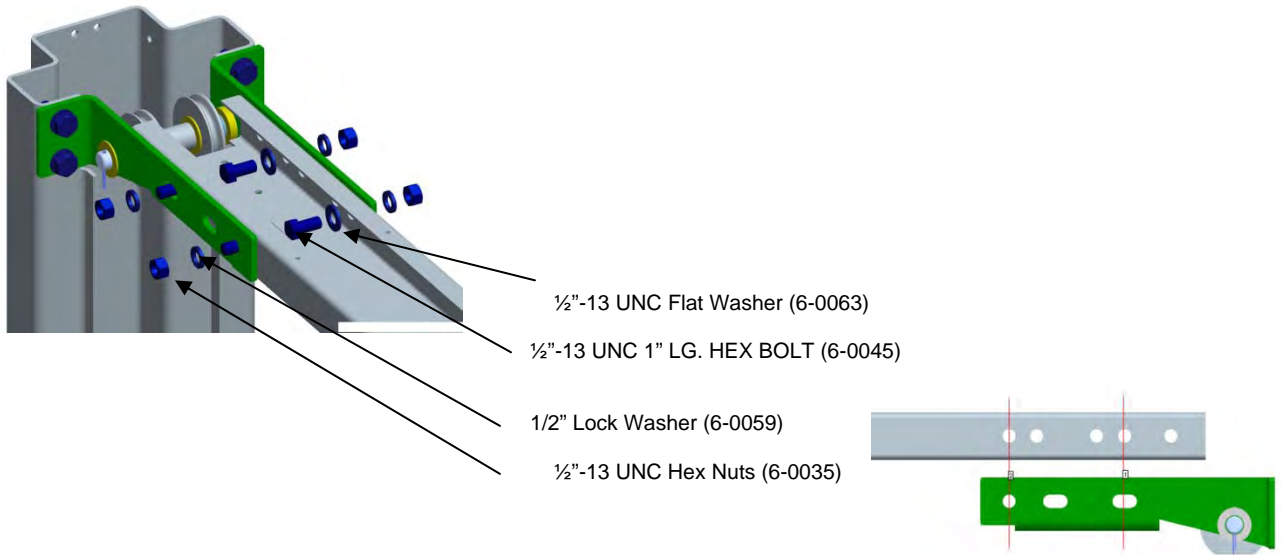

7.4 SAFETY SHUT-OFF BAR INSTALLATION

The safety shut off will disconnect the power to the power pack when an obstruction touches the padded bar or the carriages reach their maximum height. The safety shut off switch is factory pre-wired.

5.4.1 Attach the Actuator Mounting Bracket (1-1378) to the crossmember

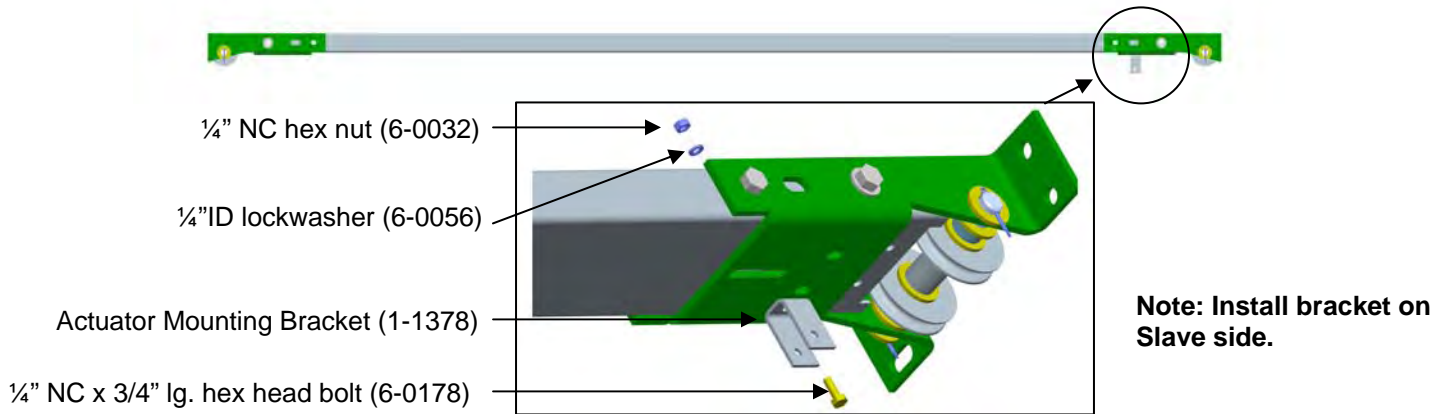

5.4.2 Attach the Actuator Bar to the Actuator Mounting Bracket.

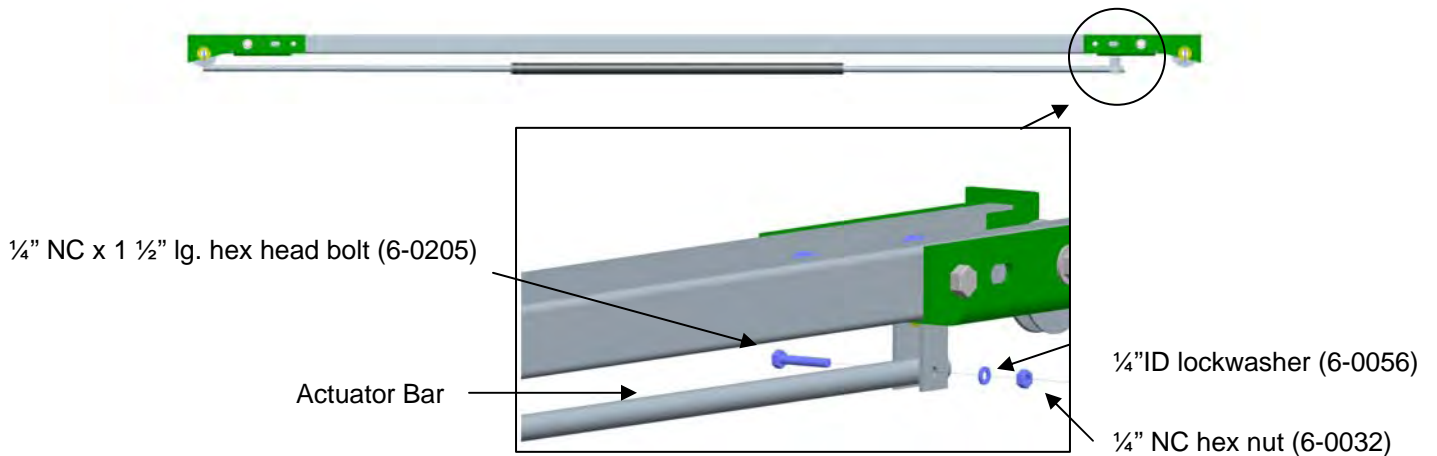

5.4.3 Slide Safety Shut-Off Microswitch Assembly over the open end of actuator bar.

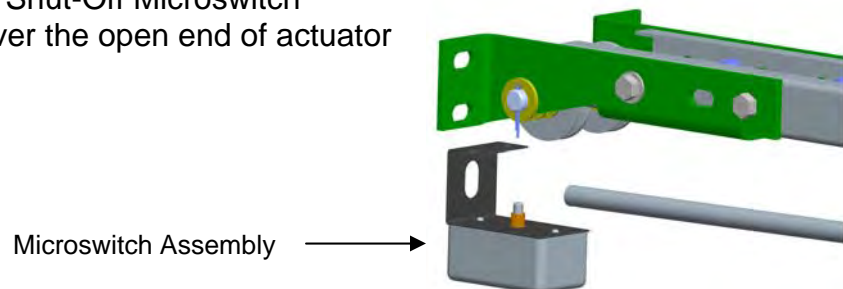

Bolt the assembly to the crossmember.

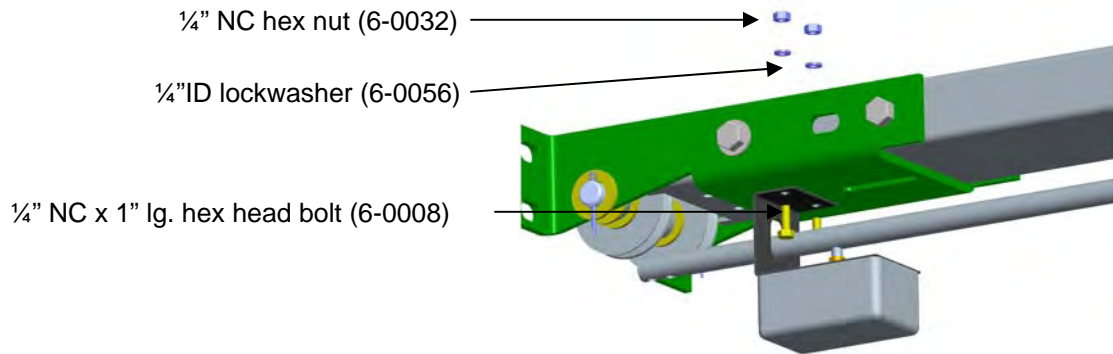

7.5 ROUTING OF EQUALIZATION CABLE

5.5.1 Manually lift the carriages to the first safety latch.

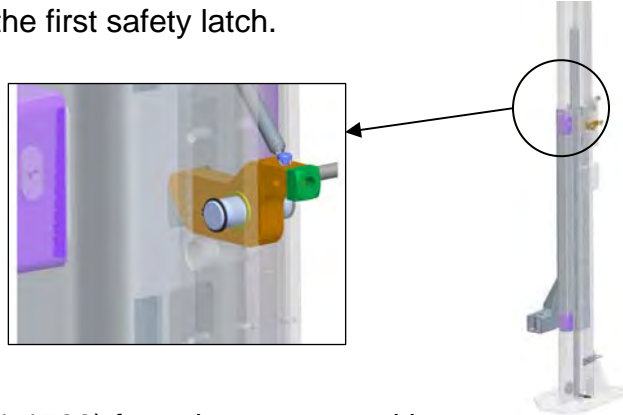

5.5.2 Remove equalizing cables (1-1786) from the accessory kit box, and 8 ½"- 13UNC nuts from a polybag in the hardware kit box.

5.5.3

Insert the short threaded stud through the 9/16" dia. hole at the bottom of the carriage.

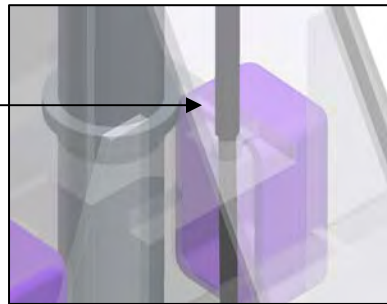

Pass the cable until it reaches the top opening. Tighten a ½"-13UNC nut to the center of the stud, and then **firmly tighten** a second nut up against it using two wrenches.

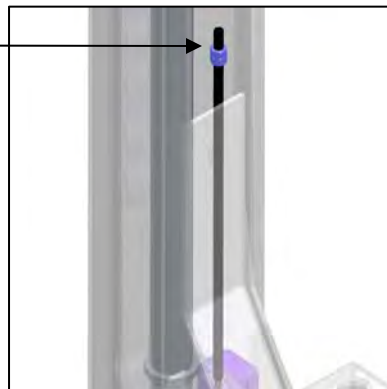

5.5.4 Pull the cable back down on to the carriage bottom plate.

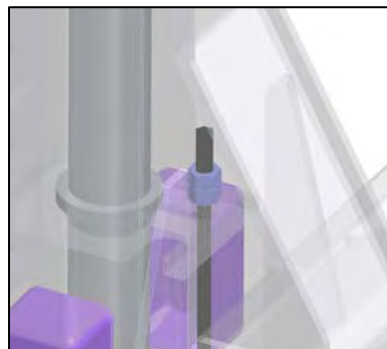

5.5.5 At the bottom of the column, remove the hitch pin, pulley pin and pulley from the base plate.

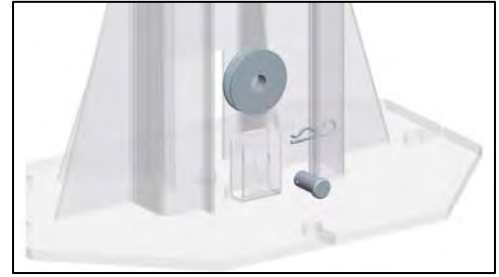

5.5.6 Route equalizing cable around pulley and reassemble the pulley to the base plate. **IMPORTANT – Hitch pin must be installed securely.**



5.5.7 Route Cable as shown.

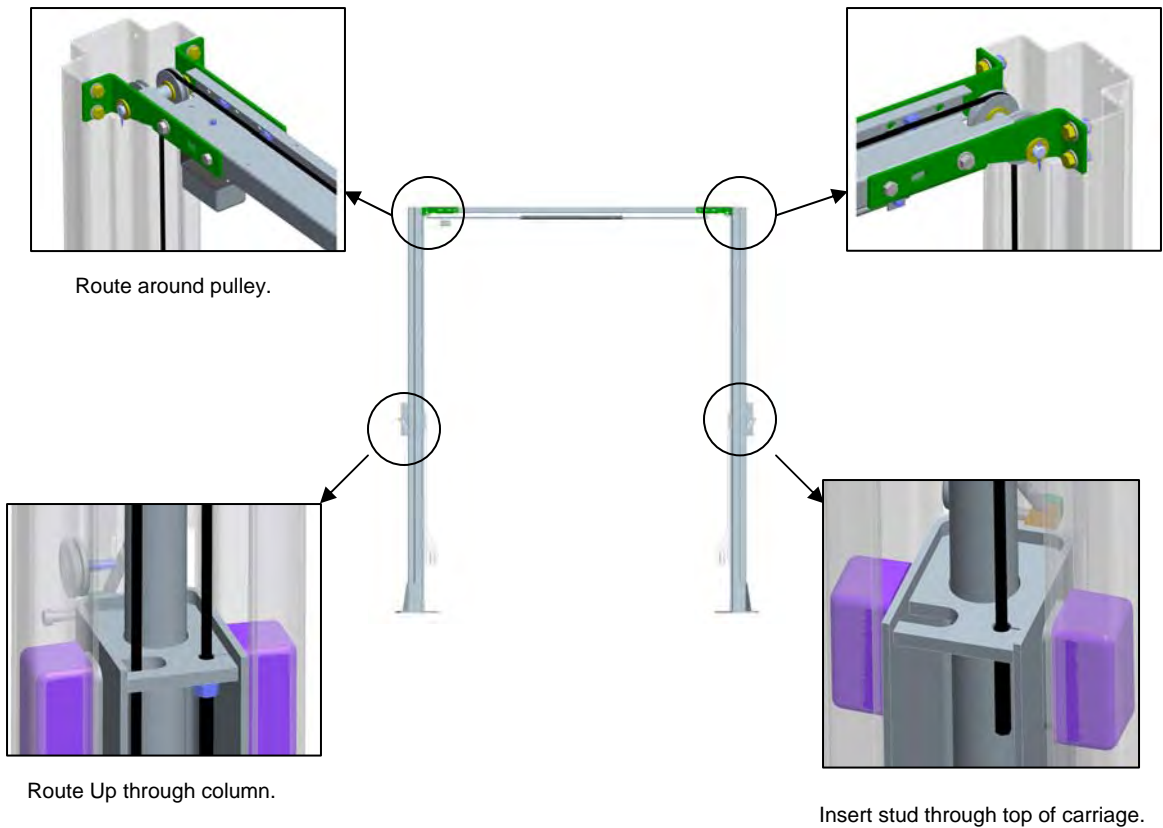

5.5.8

Use a wrench to hold the top of the threaded stud to prevent it from rotating.

Hand tighten (2) ½"-13 UNC nuts onto the threaded stud enough to remove all visible cable slack

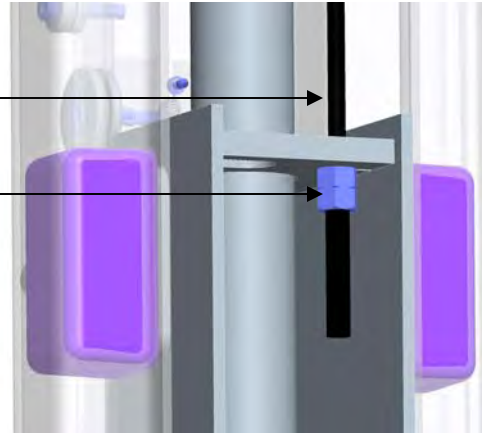

5.5.9

Hold the top of the threaded stud using wrench.

Tighten the first nut approximately 1 ½" to tension cable.

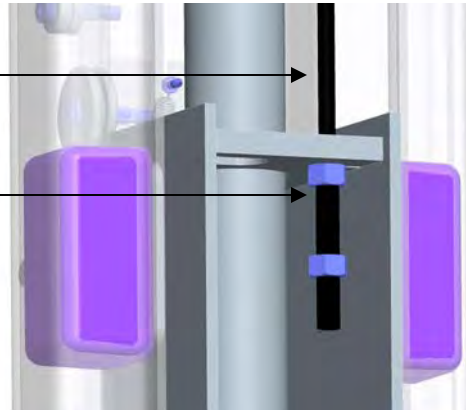

5.5.10

Tighten the second nut firmly against the first one.

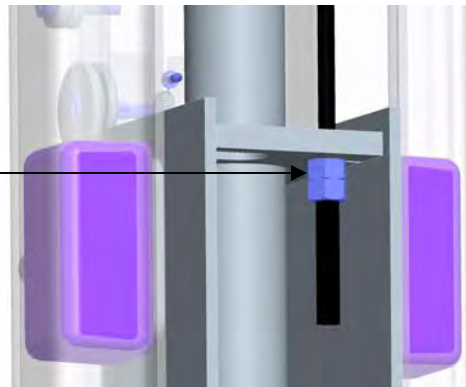

5.5.11 Repeat steps for other cable.

7.6 ARM INSTALLATION

1. Remove the four (4) 5/16"-18UNC x 3/4"LG. hex head bolts that are holding the arm pins to the arm. Install the arms on the carriages.
2. Grease and insert arm pins. Align the notch on each arm pin with the tapped hole on the arm, and using the 5/16"-18UNC x 3/4"LG. hex head bolt removed in previous step, reinstall and tighten securely.



NOTE: Make sure the hex head bolts, 5/16" dia. x 3/4" lg. (6-0801), is lock tight into arms.

3. Insert arm restraint weldment through holes in carriage weldment. Arm restraints must pass through holes in top and bottom of carriage.
4. With carriage on the first safety position, slide the spring onto the arm restraint pin closer to the inside of the lift.
5. Insert roll pin to retain the spring.
6. Repeat the above steps for remaining Arm Assemblies and Arm Restraints.

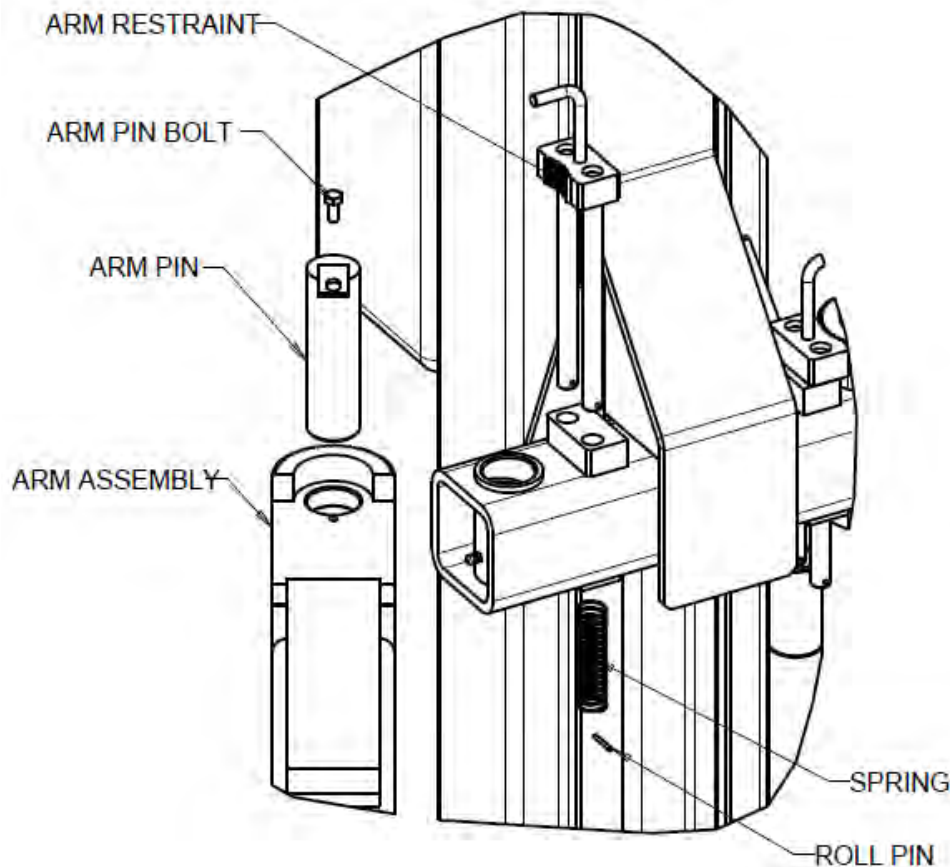

7.7 SAFETY RELEASE CABLE ROUTING AND ADJUSTMENT

The mechanical safety automatically engages. To release the mechanical safety, you must first raise the lift approximately 2", then pull the safety release lever down. This disengages the power side safety dog and activates the safety cable to release the slave side safety dog.

- 7.7.1 Install the safety release handle (1-1113) onto the power side safety dog.

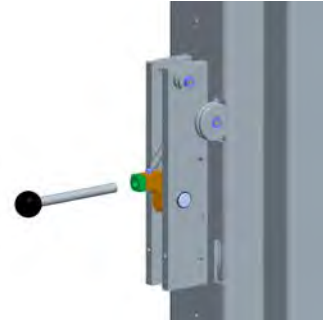

- 7.7.2

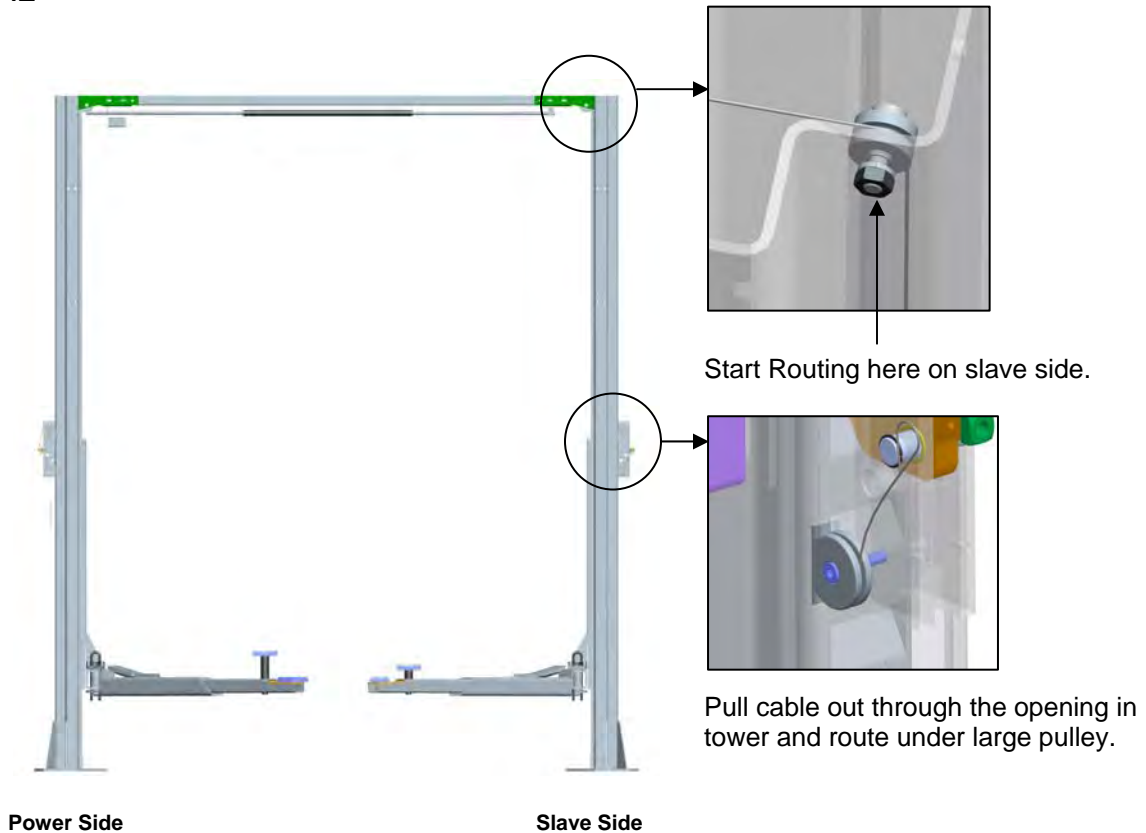

7.7.3 Fix the collar of the safety release cable to the shoulder bolt on the safety dog.

NOTE: Make sure shoulder bolt, 3/8" dia. x 1 1/2" lg. (6-0801), is lock tight to safety dog.

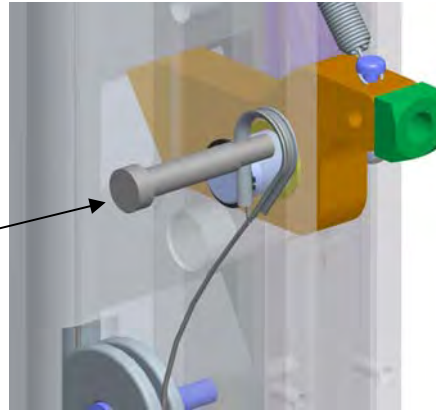

7.7.4

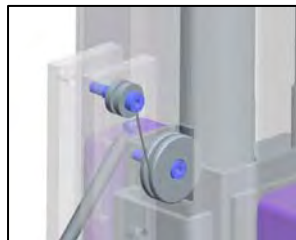
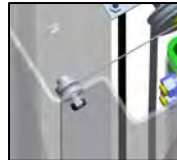

Guide the cable up under the large pulley on the power side.



Over the small pulley towards the safety dog.

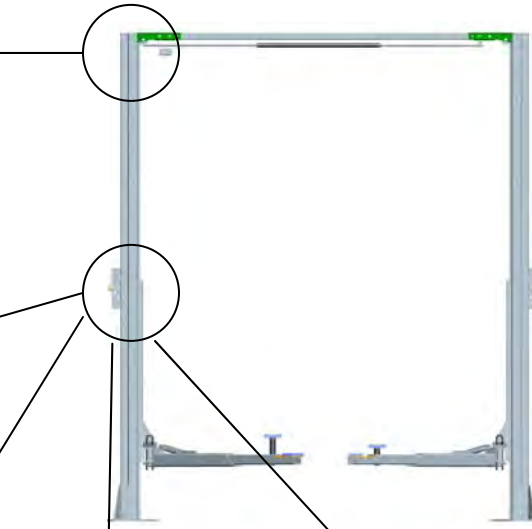

Power Side

Slave Side

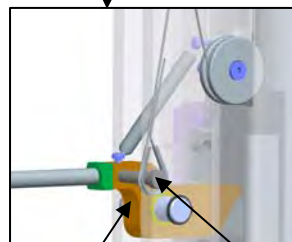

Wrap around the Thimble (6-2074)

3/8" x 1 1/2" lg. shoulder bolt (6-0801)

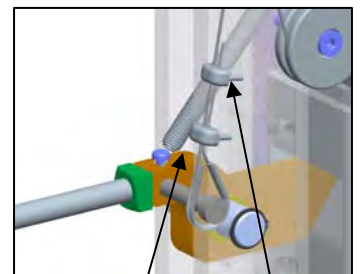

Clamp using wire rope clips (6-2060)

Do not tighten fully at this stage.



7.7.5 Adjust the cable length so that both safety dogs travel from full engagement position to full release position when the safety release handle is pulled.

Tighten both wire rope clips firmly when adjustment is completed.

7.8 POWER PACK INSTALLATION

- 5.9.1 Remove the **red** plastic cap located at the rear of the power pack, and install the "T" fitting located in the hardware kit.

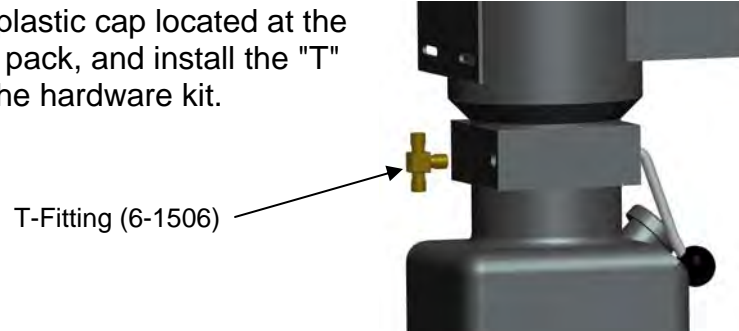

- 5.9.2 Bolt power pack to the mounting bracket on the power side tower using hardware from the kit. **Do not tighten.**

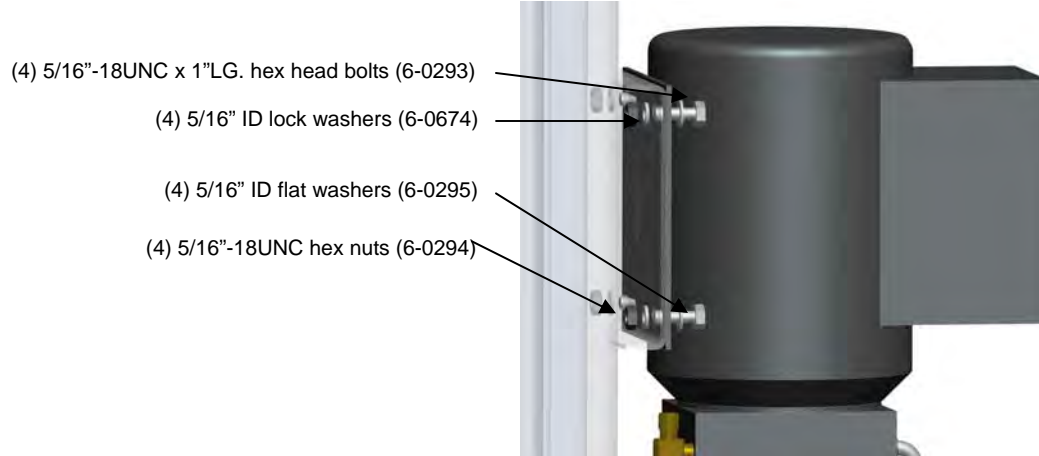

- 5.9.3 Remove the filler cap from the powerpack and fill the reservoir with approximately 4.5 Gal. (18L) of ISO32 hydraulic oil (10 wt. hydraulic oil).

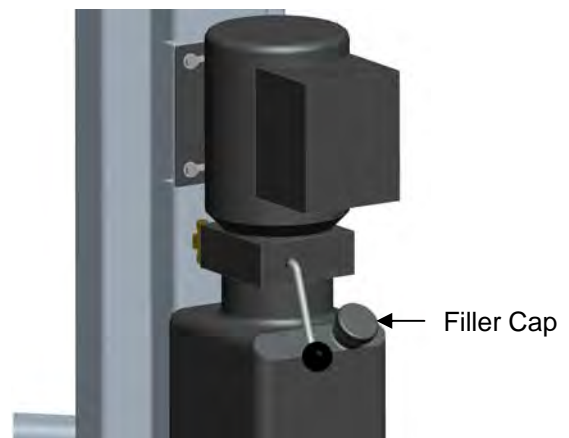

5.9.4 A **certified electrician** must connect the 230Volt/1Ph power to the motor.

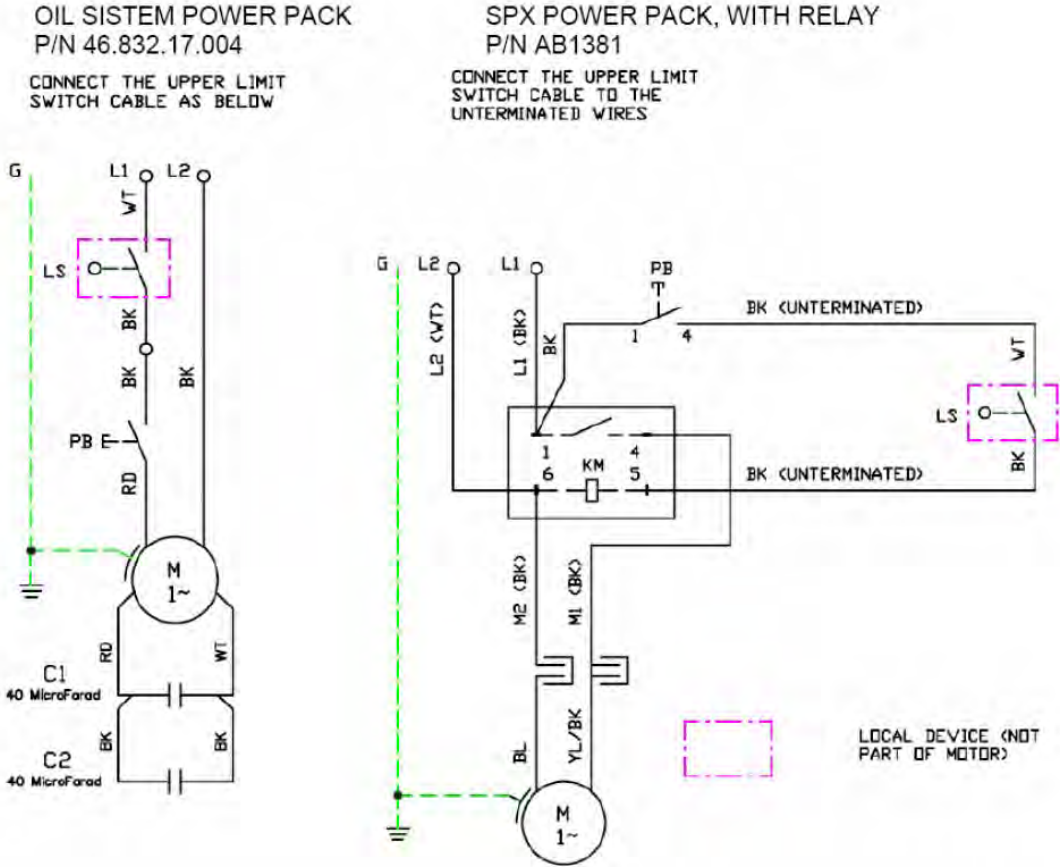

7.9 HYDRAULIC SYSTEM INSTALLATION

5.10.1 Connect long hose to the top port on "T" fitting.

45° End of Long Hose (2-1486)

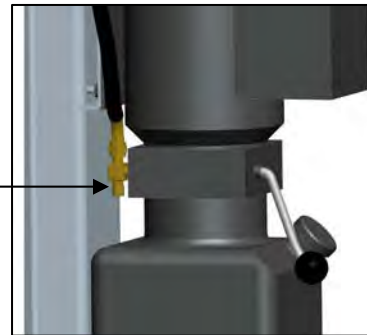

5.10.2 Connect short hose to the other end of the "T" fitting.

45° End of Short Hose (2-1230)

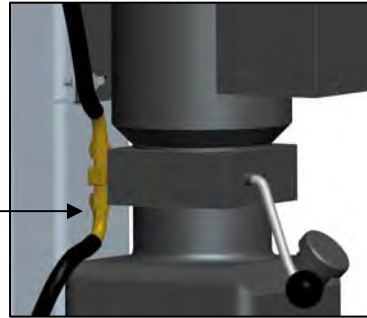

5.10.3 Remove the plastic cap from the bottom of the power side cylinder and connect the short hose to the cylinder.

90° End of Hose

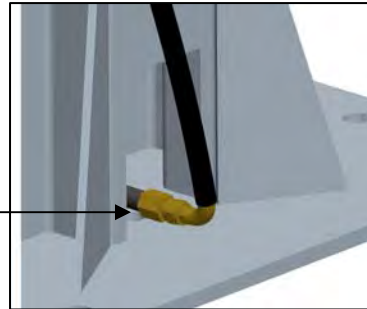

5.10.4

Loop the hydraulic hose up the power side tower, across the overhead and down the slave side tower.

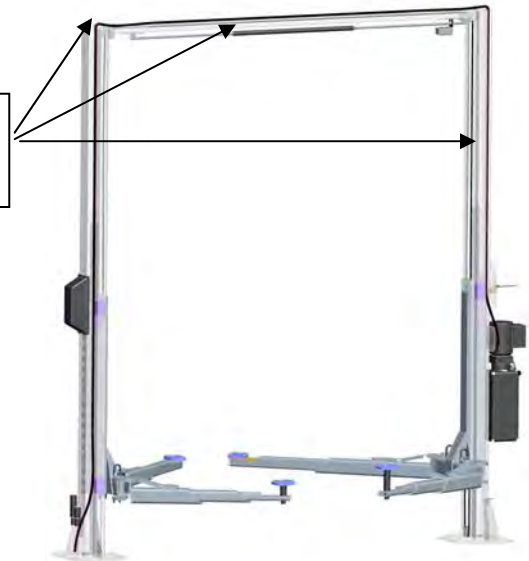

5.10.5 Remove the plastic cap from the bottom of the slave side cylinder and connect the long hose to the cylinder.

90° End of Hose

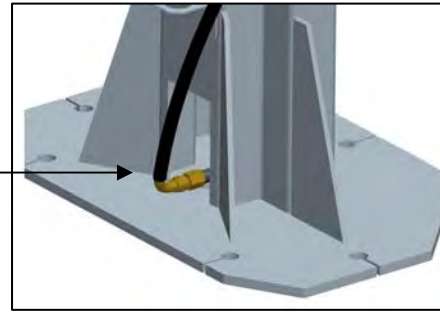

5.10.6

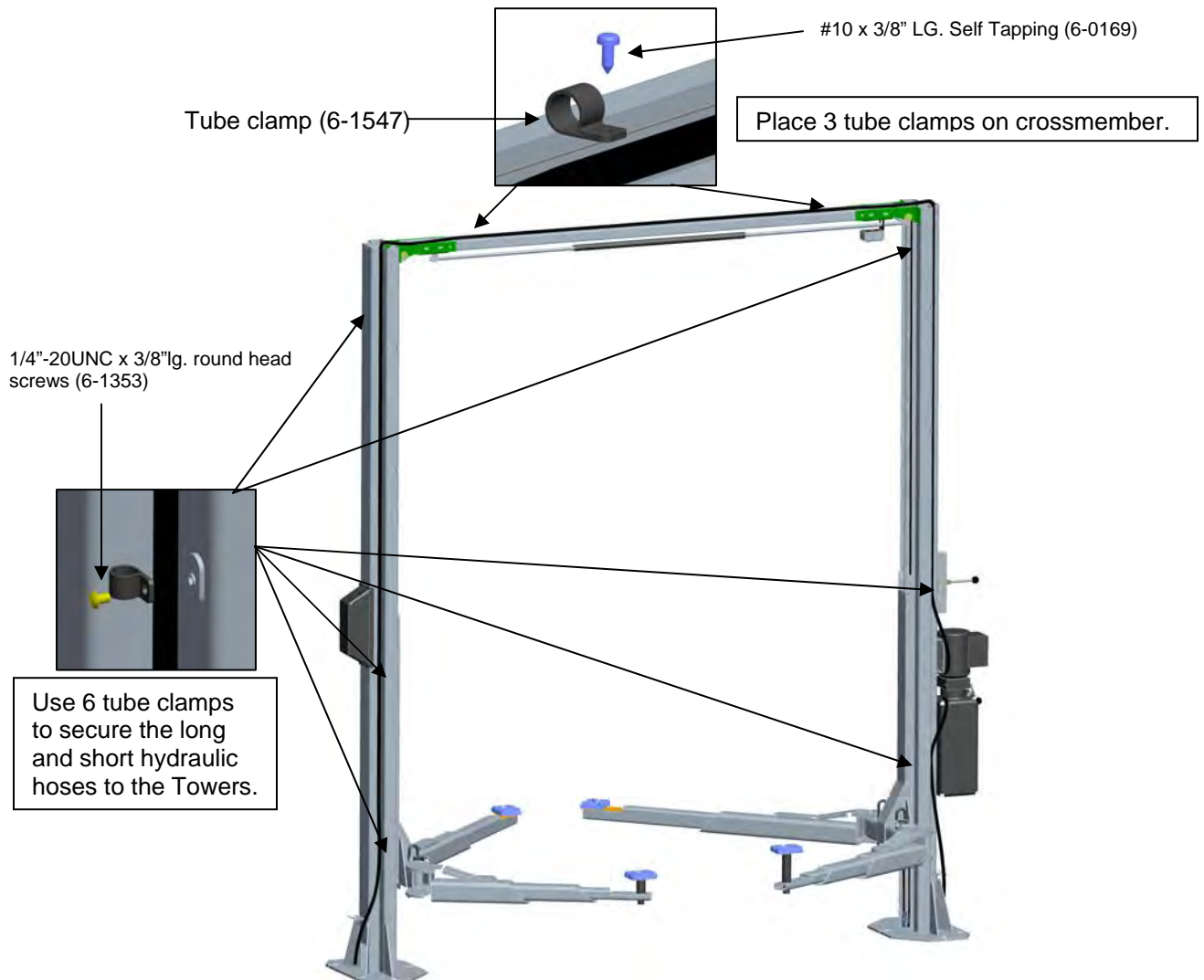

7.10 HYDRAULIC SYSTEM BLEEDING

- 5.11.1 Crack the bleeder valve located at the top of both cylinders (approx. $\frac{1}{4}$ turn)

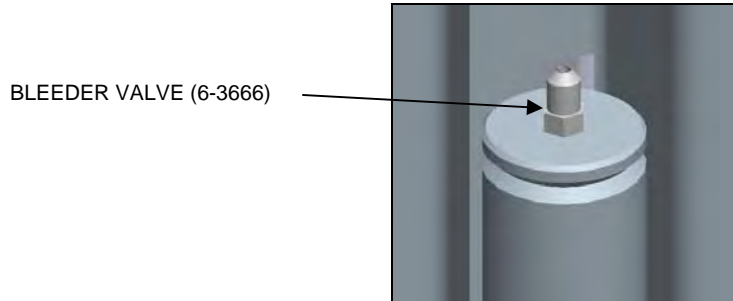

- 5.11.2 Power up 2"-3". You should hear air escaping around the bleeder valve. Repeat 3 – 4 times or until only oil is coming out of the bleeder valve.
- 5.11.3 Tighten the bleed screw and lower the lift.

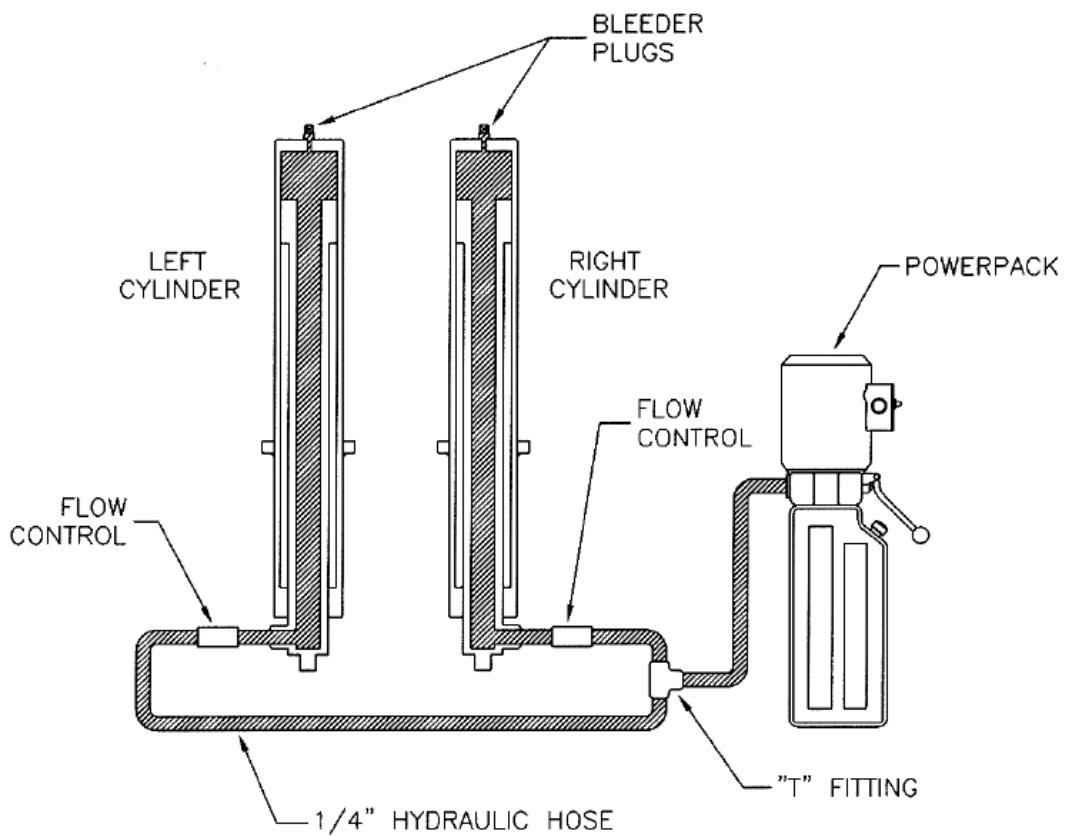

7.11 TOWER POSITIONING AND ANCHORING

WARNING! Failure to follow these instructions may cause an unsafe operating condition.

WARNING! Before proceeding with installation, review Section 4: Installation & Tools.

7.11.1 Determine which column is higher using a 4ft level.

Place 4 ft. Level.

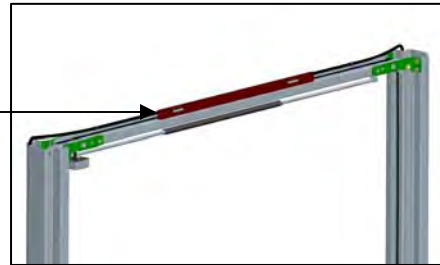

7.11.2 Check if high column is level in the vertical position.

Place 2 ft. Level.

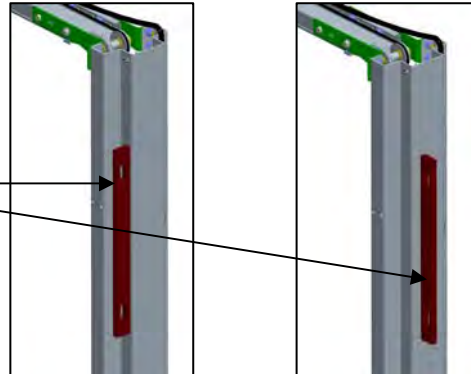

Note: Use shims under baseplate to level the column.

Ensure that the base plate is completely supported by shims including near the center where it does not contact the floor.

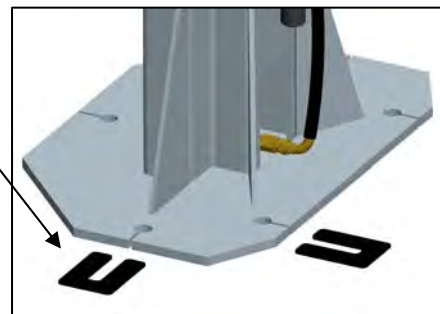

7.11.3 Refer to Bay Layout to ensure that the column is still in the proper position.

7.11.4 Prior to installing anchors, assemble the nut and washer onto anchors. A minimum of six threads must be visible below the surface of the nut. Refer to the figure below while reading through the following instructions.

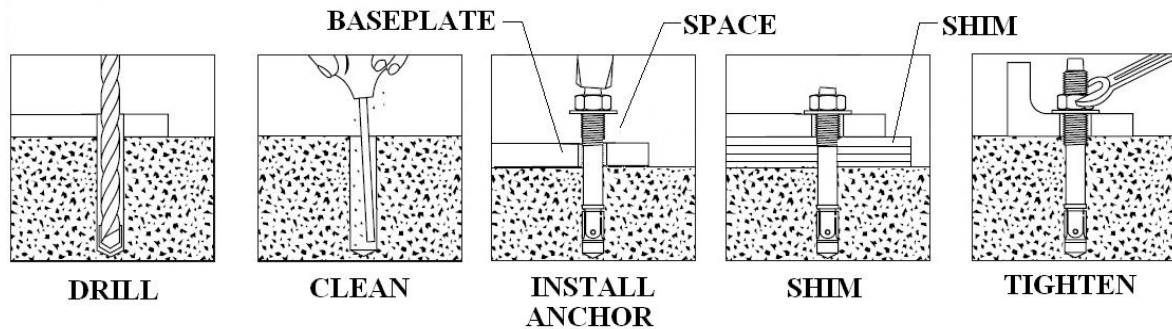

7.11.5 Using a $\frac{3}{4}$ " concrete drill bit and rotary hammer drill, drill $\frac{3}{4}$ " holes for the anchor bolts on the high side column. Drill through the concrete floor. (In case longer anchors are required, supplied anchors can be hammered through concrete).

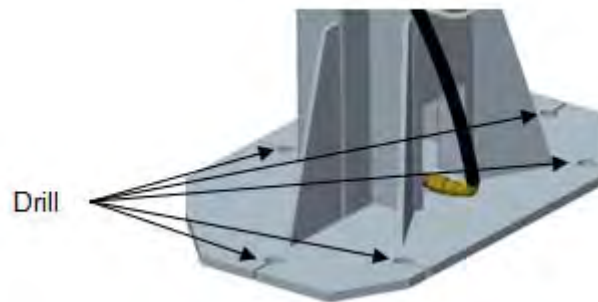

7.11.6 Clean out the drilling dust from the holes and hammer in the anchor bolts until they make contact with the baseplate. **Hand tighten all anchor bolts.**

Check that the column is level front to rear and side to side. Adjust shims as required.

7.11.7 **Torque all anchor bolts to 150 ft-lbs. (203 Nm)**, continually checking that the column is level as you proceed.

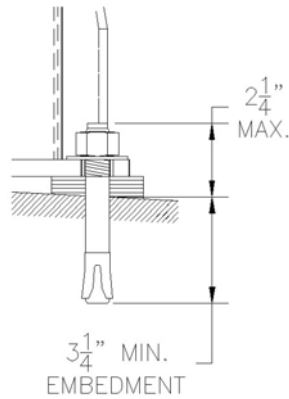
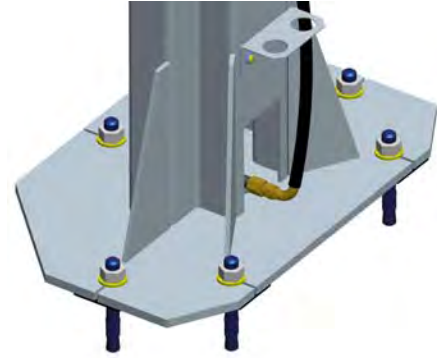

NOTE:

The 3/4" × 5 1/2" lg. wedge anchor bolts supplied must have a minimum embedment of 3 1/4" into concrete floor.

If anchor bolts do not tighten to 150 ft-lbs. OR project more than 2 1/4" above the concrete surface due to floor slope, the concrete should be replaced by an appropriate concrete pad. (Consult Product Manufacturer / Supplier for further details).

7.12 POSITION AND ANCHORING OF REMAINING TOWER

7.12.1 Level the low side column by shim underneath the baseplate.

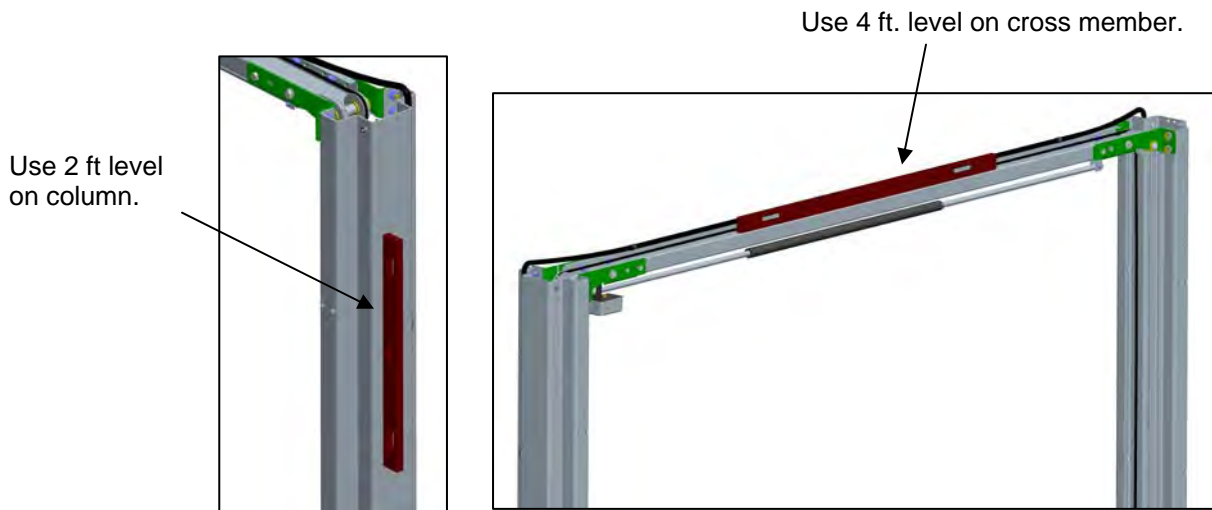

Ensure that the baseplate is completely supported by shims where it does not contact the floor.

7.12.2 Refer to Bay Layout above to ensure that the column is still in the proper position.

7.12.3 Prior to installing anchors, assemble the nut and washer onto anchors. A minimum of six threads must be visible below the surface of the nut. Refer to the figure below while reading through the following instructions.

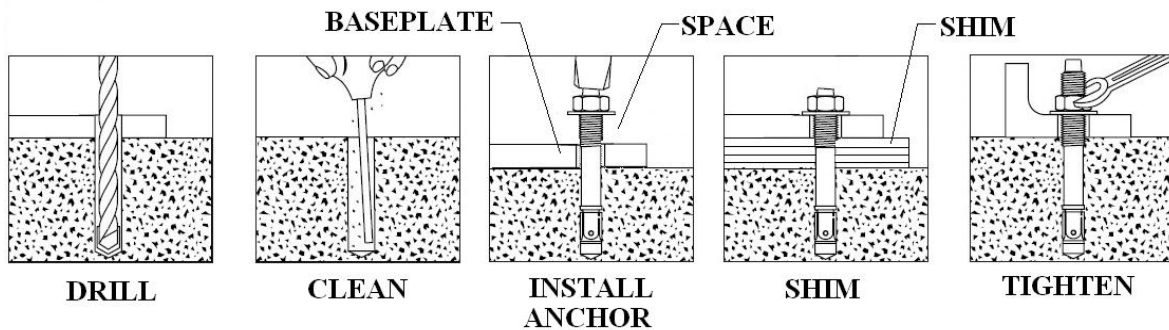

7.12.4 Using a $\frac{3}{4}$ " concrete drill bit and rotary hammer drill, drill $\frac{3}{4}$ " holes for the anchor bolts on the high side column. Drill through the concrete floor. (In case longer anchors are required, supplied anchors can be hammered through concrete).

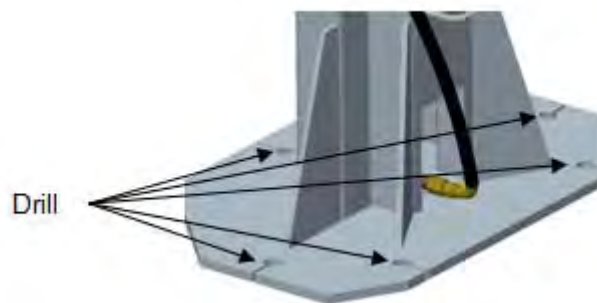

7.12.5 Clean out the drilling dust from the holes and hammer in the anchors until they make contact with the baseplate. **Hand tighten all anchor bolts.**

Check that the column is level front to rear and side to side. Adjust shims as required.

7.12.6 **Torque all anchor bolts to 150 ft-lbs. (203 Nm)**, continually checking that the column is level as you proceed.

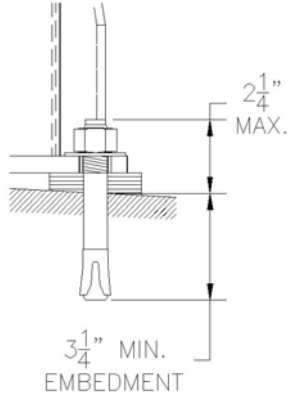

NOTE:

The 3/4" × 5 1/2" lg. wedge anchor bolts supplied must have a minimum embedment of 3 1/4" into concrete floor.

If anchor bolts do not tighten to 150 ft-lbs. OR project more than 2 1/4" above the concrete surface due to floor slope, the concrete should be replaced by an appropriate concrete pad. (Consult Product Manufacturer / Supplier for further details).



7.12.7 Verify that the entire lift is level both horizontally and vertically to ensure optimum lifting performance. **NOTE: Perform a monthly inspection and torque all anchor bolts to 150 ft-lbs. (203 Nm).**

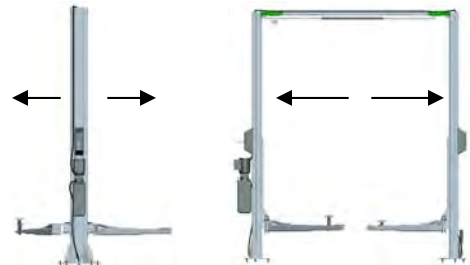

7.13 SAFETY SHUT-OFF BAR ADJUSTMENT

5.14.1 When the lift is fully installed, leveled and operational, extend the carriages to their full upper limit.



5.14.2 Lower the carriages about 1/4" to 1/2".

5.14.3 Attach a 1/4" bolt and nut to actuator extension.

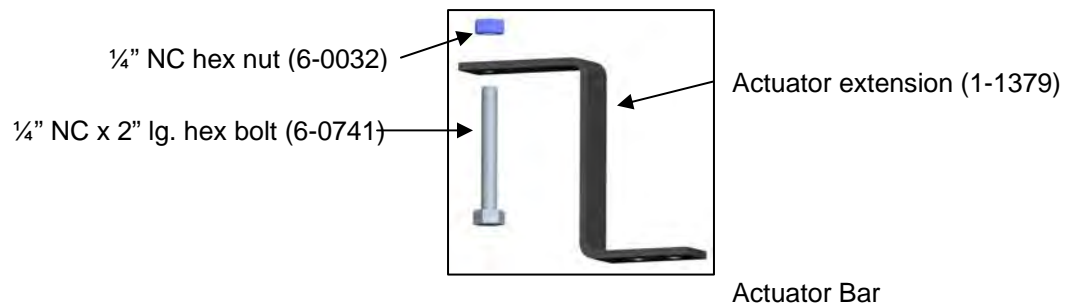

5.14.4 Bolt the Actuator Extension onto the open end of actuator bar.

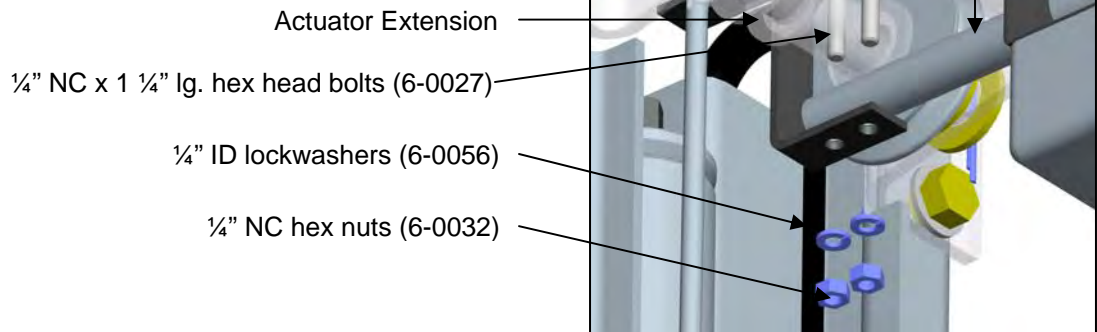

5.14.5 Adjust the 1/4" NC x 2" lg. hex bolt so that the end of the bolt is in contact with the carriage. Tighten the 1/4" NC hex nut on the bolt.

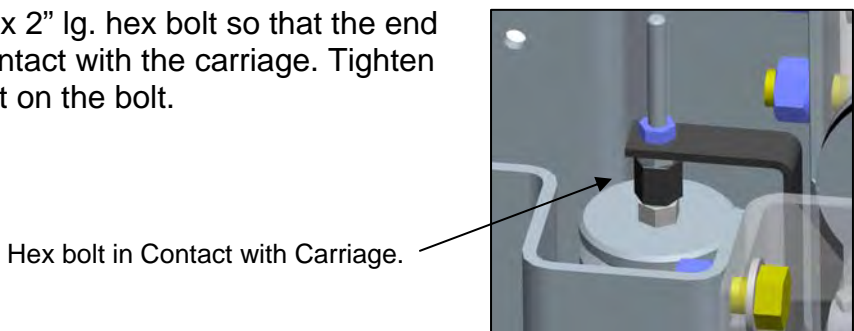

8.0 FINAL CHECK OF ASSEMBLED LIFT

1. Final dimension check after anchoring	
2. Check for hydraulic leaks.	
3. Ensure cables are properly routed and free from obstructions.	
4. Check jam nuts on cables are tightened.	
5. Check that LOCTITE has been applied to all hardware where required.	
6. Check adjustment of safety release cable to ensure both sides	
7. working properly.	
8. Re-check level of towers.	
9. Check torque of anchor bolts.	
10. Check all fasteners, tighten if necessary.	
11. Check shut off at top of stroke to ensure lift shuts off.	
12. Check proper operation of arm restraints.	
13. Operate lift to full stroke then lower to ground while checking for proper functionality.	
14. Check proper operation of arm restraints.	
15. Ensure Customer Care Kit is complete and given to operator.	
16. Operation Manual	
17. ANSI / ALI Lift It Right Manual	
18. ANSI / ALI Safety Tip Card	
19. ANSI / ALI ALIS Safety Requirements for Installation	
20. ANSI / ALI Quick Reference Guide	
21. Train end user on operation of lift.	

9.0 OPERATING INSTRUCTIONS

Read and understand all safety and operation labels on the lift. Refer to the "**Lifting it Right**" manual and "**Safety Tips**" card supplied to you for additional important instructions and information.

NOTE: Some vehicles may have the manufacturer's Service Garage Lift Point locations identified by triangle shape marks on its undercarriage (reference SAE J2184). Also, there may be a label located on the right front door lock face showing specific vehicle lift points. If the specific vehicle lift points are not identified, refer to the "Typical Lift Points" figure below or the ANSI/ALI **Lift Point Guide** included with your lift.

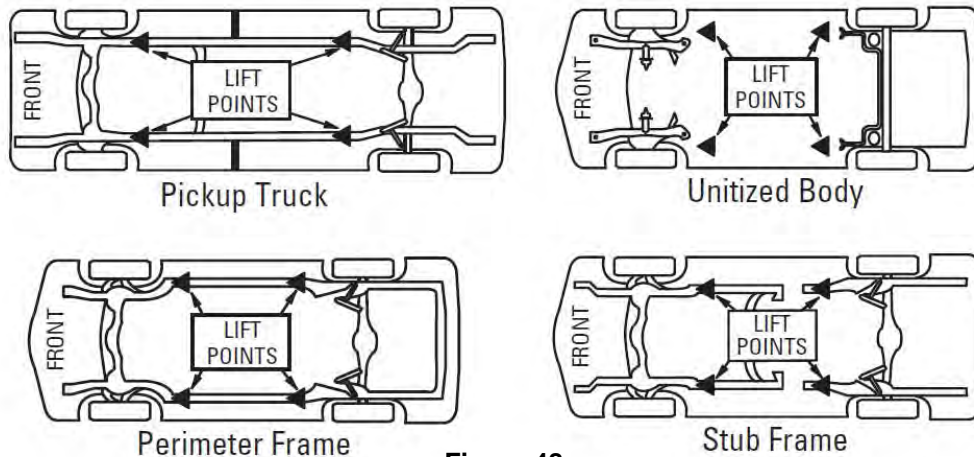
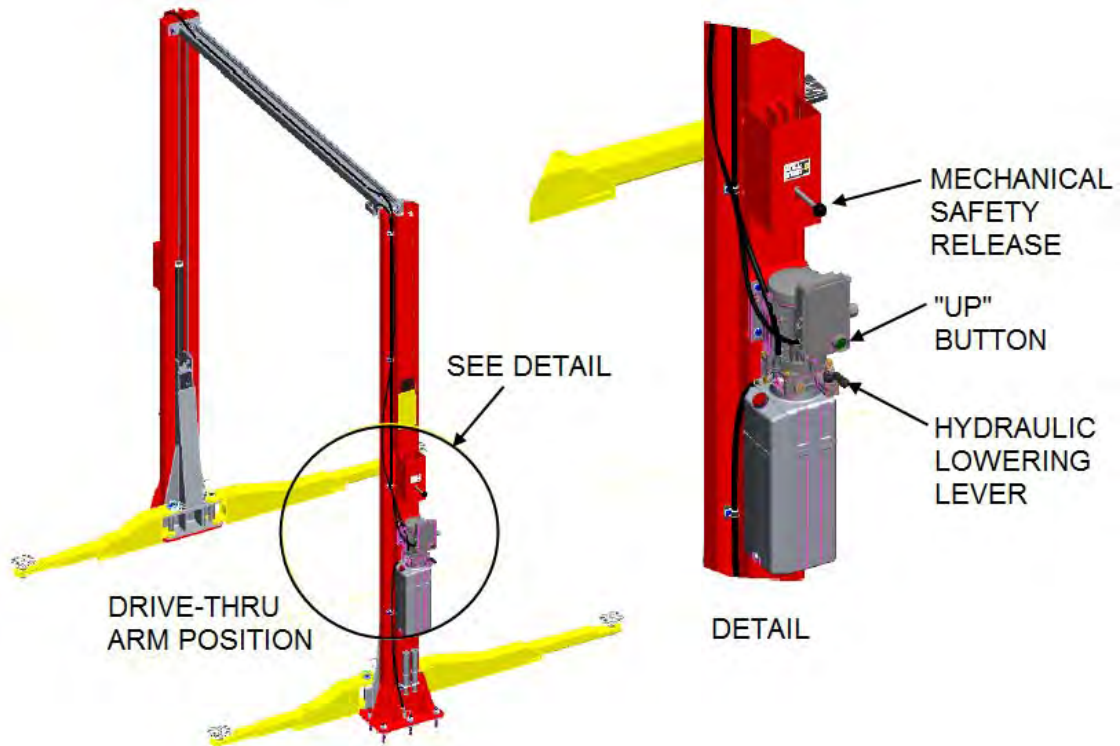

Figure 48

1. Position arms to drive-thru position (see figure 49).
2. Refer to supplied literature prior to loading vehicle. Center the vehicle between the lift post.
3. Only lift the vehicle on the manufacturers recommended lift points. Refer to supplied lift points guide (reference ANSI/SAE J2184-1992).
4. Locate lift pads on auto manufacturer's recommended lift points. Once you have correctly positioned the lift arms, ensure that all arm restraints are properly engaged.
5. Raise the vehicle by pushing the "UP" button on the powerpack until the vehicle's suspension has left the ground.
6. Inspect to make sure there are no interference with any objects and for proper engagement of the lifting pads.
7. Shake vehicle moderately by pushing on either the front or rear bumper. Visually inspect the lifting pads again. If the vehicle starts slipping on the lifting pads, or otherwise appears unstable on the lift, you have positioned the swing arms and adapters incorrectly. Carefully lower the lift and start over.
8. When satisfied, continue lift the vehicle to the desired working height, lower onto the mechanical safety using the lowering lever.
9. Once vehicle is ready to be removed, raise lift so that the mechanical safety can be released. Pull down and hold the mechanical safety release lever, then press the hydraulic lowering lever until the lift has fully collapsed to the grounds and the arm restraints are disengaged.
10. Swing the lift arms to the drive-thru position prior to moving the vehicle.



9.1 OPERATION TEST WITH VEHICLE

Prior to starting this section, please refer to Section 2 of this manual for important safety instructions.

1. Lower lift to ground.
2. Drive vehicle on to lift and locate the arms as per the "Lift it Right" manual.
3. Raise lift to and lower onto 3-4 lock positions during full rise to ensure all locks are working correctly.
4. Re-adjust cables if necessary while vehicle is on.
5. Check lowering speed and smooth decent rate.
6. Lower lift to ground and drive vehicle off lift.

If any problems occur during the final checkout or operation of the lift please contact customer service at 1-800-268-7959

10.0 MAINTENANCE GUIDELINES

10.1 SAFETY INSTRUCTIONS

Refer to Section 2 for more Safety Instructions.

Read operating and safety manuals before using any lift.
Do not operate a lift that has been damaged or is in disrepair.
Proper inspection and maintenance is necessary for safe operation.

10.2 PERIODIC MAINTENANCE

DAILY:

1. Check all hydraulic lines and fittings for pinch points , damage , cracks or leaks
2. Check all electrical wiring for pinch points , cracks or damage
3. Check all moving parts for uneven or excessive wear
4. Repair or replace all damaged, defective, worn or broken components immediately.
5. Check the telescopic arms for movement. Clean any grease or oil from the lifting adapters.
6. Raise and lower the lift at the beginning of each shift, without a vehicle on, to verify the lift is leveled and operating properly.

EVERY TWO MONTHS:

1. Clean and re-grease slide block channels inside of both columns
2. Grease arm pins
3. Lubricate safety dogs and check safety release cable adjustment
4. Check arm restraints and lubricate
5. Check anchor bolts and re-torque if required

EVERY FOUR MONTHS:

1. Dismantle and clean inner arms
2. Lubricate cable pulleys
3. Check equalizing cable adjustment

EVERY YEAR:

1. Inspect lift as per Automotive Lift Operation, Inspection and Maintenance (ALOIM)

EVERY TWO YEARS:

1. Change hydraulic fluid

LUBRICATION:

Where grease is required > multi-purpose lithium grease

Where lubricating oil is required > multi-purpose SAE 30 lubricating oil

Where hydraulic oil is required > ISO 32 10W - non detergent hydraulic oil

NOTE: If the lift locks, while in the fully raised position this will indicate that the hydraulic system has not been inspected or maintained as recommended. This is a safety back-up system. If you are unclear call your local representative immediately.

11.0 WIRE ROPES

⚠ WARNING

- Wire ropes are critical to safe and reliable performance of your lift.
- Cables are expendable items and should be replaced as a set.

11.1 WIRE ROPE CONDITION GUIDE

Typical good cable



Cable with necking



Broken wires

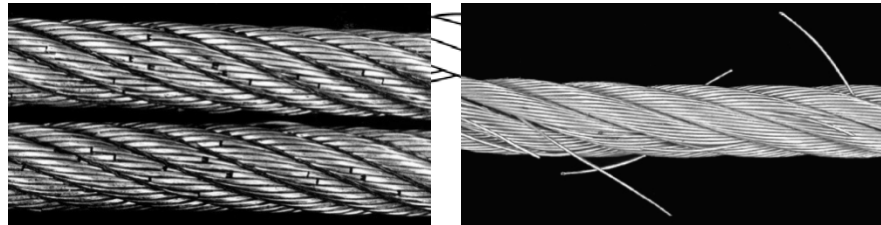

Excessive wear of wires

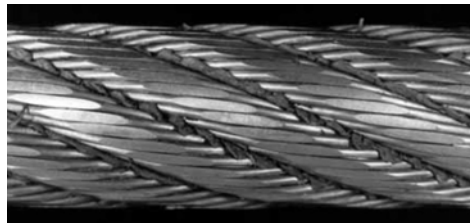

Rust on sheave stack and ropes



Corrugated sheave groove



(Pictures above are of a 4-Post Lift, conditions still apply to 2-Post Lifts)

11.2 WIRE ROPE REPLACEMENT CRITERIA:

⚠ WARNING

If any cable is found to be in need of replacement, the entire cable set, pulleys and safety rollers must be replaced immediately.

See **10.1**, cable conditions guide.

In the following table, "lay" means the distance measured along a line parallel to the axis of the rope in which the strand makes one complete turn about the axis of the rope, or the wires make a complete turn about the axis of the strand.



The wire rope must be removed from service if one or more of the following criteria are met:

1. More than six randomly distributed broken wires in one rope lay or $6 \times d$ length.
2. More than three broken wires in one strand in one rope lay or $6 \times d$ length.
3. Three or more broken wires at rope terminations.
4. One outer wire broken at the point of contact with the core of the rope which has worked its way out of the rope structure and protrudes or loops out from the rope structure
5. Heavy rusting, corrosion, or pitting. A light surface corrosion on outer wires is normal.
6. Wear or scraping of one-third of the original diameter of outside individual wires
7. Excessive stretch. It is normal for new cable to require adjustment during "break-in", after which small periodic adjustments may be required. However, if a cable that has been in service for 6 months should suddenly require frequent adjustments or has used all the cable adjustment available, all cables must be replaced immediately.
8. Deformed strands, kinking, crushing, bird-caging, or any other damage or distortion of wire rope structure
9. Variations in diameter (necking) or any change from normal appearance
10. Reductions from nominal diameter of more than $1/32$ " (for cables $3/8$ " to $1/2$ " dia. inclusive)
11. End attachments cracked, deformed or worn

11.3 WIRE ROPE INSPECTION

Inspect wire rope cables for wear or damage. Wipe cables with a rag to detect hard to see small broken or frayed cable strands. See chapter **9.2**, **Fig.75** and ANSI/ALI ALOIM standard.

11.4 WIRE ROPE LUBRICATION

Lubricate wire ropes with lift in both lowered and raised position, by spraying them with wire rope lubricant (i.e. 2001 MONOLEC®) and wiping the cable down.

11.5 WIRE ROPE ADJUSTMENT

Adjust cables if lifting is uneven or lift is not level (See chapter 7.15.3). Never make adjustments with weight on lift. If running out of adjustment threads, cables need to be replaced. Do not add washers or other spacers to re-use previously used adjustment threads.

Wire rope tension adjustment should be performed when installing the lift and every three months.

13.0 TROUBLESHOOTING GUIDE

PROBLEM	REASON	SOLUTION
Power Pack (Motor) not running.	Bad Fuse or Circuit breaker.	Replace bad fuse or reset circuit breaker.
	Incorrect voltage to motor.	Provide proper voltage to motor.
	Improper wiring.	Have certified electrician check wiring.
	Power Pack up switch not functioning.	Replace Power Pack up switch.
	Overhead Microswitch not functioning.	Replace overhead Microswitch.
	Power Pack motor burned out.	Replace motor.
Power Pack (Motor) runs but lift does not go up.	Low oil level.	Fill reservoir with proper hydraulic oil.
	Oil valve remains open.	Repair or replace oil valve.
	Pump sucking air.	Tighten all fittings and suction lines.
Lift goes up slowly or oil coming out from filler cap.	Air in hydraulic fluid lines	Bleed hydraulic lines (Call installer).
Lift doesn't come down.	Dirt in directional valve	Call installer to clean valve. (Do not attempt to open hydraulic lines unless vehicle is secure)
Safety Dog does not engage.	Safety Dog jammed.	Oil or replace pin to free Safety Dog. Check or replace spring.
Safety Dog does not disengage.	Safety dog is being limited	Check for any obstructions.
Lift goes up unlevel.	Equalizing cables are loose.	Adjust equalizing cables to correct tension.
	Floor unlevel.	Shim lift to make towers level. (Do not exceed 1/2" of shimming).
Lift goes up with chatter or does not fully rise.	Low oil level.	Fill reservoir to correct level with proper hydraulic oil.
	Air in hydraulic fluid lines/cylinder.	Bleed hydraulic lines. (Call installer).
Anchor bolts do not stay tight.	Holes are too large.	Relocate lift using proper size drill bit.
	Incorrect concrete floor specification (Thickness and holding strength).	Break existing floor and pour new pad for lift.
Noticeable Deflection of Arm or arm dragging on floor.	Lift out of plumb.	Plumb columns.
	Unlevel floor.	Replace floor or shim columns.
	Worn arm or carriage holes.	Replace parts.
	Worn carriage slide blocks.	Replace side blocks.
	Bent arm (Overloaded).	Replace arm. Also check damage to carriage.

14.0 LOCK OUT AND TAG OUT INSTRUCTIONS

IMPORTANT: This machine does not have integral devices that will isolate the electrical, pneumatic, stored and hydraulic energy source. Appropriate isolation or blocking devices must be used that have the provisions to be switched in the off position and locked in that position.

ALL MAINTANANCE AND SERVICE MUST BE PERFORMED BY A QUALIFIED PERSON.

ALL MAINTANANCE AND SERVICE MUST BE PERFORMED WITH THE LIFT UNLOADED.

IT IS THE SHOP OWNERS RESPONSIBILITY TO ENSURE ENERGY ISOLATING DEVICES ARE:

- Accessible
- Conveniently located to facilitate the application of lockout devices during service and maintenance
- Located outside any hazardous area.
- At a convenient manipulating height (i.e. not overhead, on ladders or under machinery)
- Adequately labeled or marked. Identification shall include machine ID, energy type and magnitude.
- Capable of being locked or otherwise secured in an effective isolating position.

Effective hazardous energy control procedures will protect employees during machine and equipment servicing and maintenance where the unexpected energization, start up or release of stored energy could occur and cause injury, as well as while working on or near exposed de-energized electrical conductors and parts of electrical equipment. Hazards being guard against include being caught in, being crushed by, being struck by, being thrown from, or contacting live electrical circuits/parts.

In preparation for lockout, an initial survey must be made to locate and identify all energy isolating devices to be certain which switch, valve, or other energy isolating devices apply to the machine / equipment to be locked out. More than one energy source (electrical, hydraulic, pneumatic, or others) may be involved.

14.1 SHUT DOWN PROCEDURE:

- Notify all affected employees that a lockout or tagout system is going to be utilized and the reason for. The authorized employee shall know the type

and magnitude of energy that the lift utilizes and shall understand the associated hazards.

- **ELECTRICAL:** Located at the user control panel, press the “E-STOP” button to disconnect the raise and lower functions.

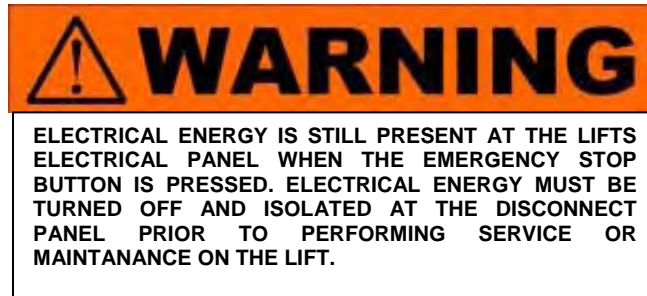

14.2 ISOLATION AND VERIFICAITON PROCEDURES:

Table 1: ISOLATION AND VERIFICATION PROCEDURES:

ENERGY TYPE AND SOURCE	LOCKOUT LOCATION (TO BE COMPLETED BY END USER)	PROCEDURE FOR LOCING OUT AND OR RELEASING ENERGIES	VERIFY PROCEDURES
<p>STORED ENERGY</p> <p>AND</p> <p>HYDRAULIC PRESSURE 3000-5000 PSI</p>		<p>LOWER THE LIFT TO ITS LOWEST REST POSTION. IF THE LIFT MUST BE SERVICED OR MAINTAINED IN THE RAISED POSITION, ENSURE THAT THE LIFT IS PLACED ON THE MECHANICAL LOCKS.</p> <p>FOR SCISSOR LIFTS, ADDITIONAL SUPPORT WITH SUPPLEMENTARY JACK STANDS, BLOCK AT THE SLIDERS AND A COME ALONG SECURED BETWEEN THE SCISSORS.</p> <p>FOR 4-POST LIFTS, ADDITIONAL SUPPORT WITH SUPPLEMENTARY JACK STANDS.</p>	<p>VERIFY THAT THE LIFT IS (IF APPLICABLE):</p> <p>CONTACTING THE MECHANICAL LOCKS,</p> <p>RESTING ON THE SUPPLEMENTARY JACK STANDS,</p> <p>BLOCKS ARE SECURLY PLACED</p> <p>COME ALONG IS SECURED BETWEEN THE SCISSORS.</p>

<p>ELECTRICAL 240VOLTS</p>		<p>AT THE LIFT, PRESS THE EMERGENCY STOP BUTTON COMPLETELY TO DE-ENERGIZE THE CONTROL BUTTONS (IF APPLICABLE).</p> <p>AT THE DISCONNECT PLANEL, PLACE THE DISCONNECT HANDLE IN OFF POSITION. ATTACH A MULTIPLE LOCOUT DEVICE. LOCK AND TAG.</p> <p><u>DANGER: LINE SIDE OF DISCONNECT REMAINS ENERGIZED</u></p>	<p>ATEMPT TO RESTART THE SYSTEM, THE SYSTEM MUST NOT START. VISUALLY VERIFY OPEN DISCONNECTS AND LOCKING DEVICE INSTALLED.</p>
<p>PNEUMATIC UPTO 160PSI</p>		<p>SLOWLY CLOSE LOCKOUT VALVE TO RELEASE AIR PRESSURE GRADUALLY. ATTACH MULTIPLE LOCKOUT DEVICE, LOCK AND TAG.</p> <p><u>DANGER: LINE SIDE OF DISCONNECT REMAINS PRESSURIZED</u></p>	<p>VERIFY THE VALVE IS CLOSED AND LOCKOUT DEVICE IS PROPERLY ATTACHED. OPERATE THE PNEUMATIC SYSTEM TO ENSURE THE SYSTEM IS DE-ENERGIZED. IT MAY BE NECESSARY TO BLEED THE SYSTEM OF REMAINING COMPRESSED AIR, THIS CAN BE PERFORMED AT THE BASE OF THE WATER SEPARATOR BOWL.</p>

14.3 RETURNING TO SERVICE:

- Check the lift and the immediate area around the lift to ensure that nonessential items,, tools and parts are removed and that the lift components are operationally intact.
- Check the work area to ensure that all employees have been safely positioned or removed from the work area.
- Notify all employees that the lockout/tagout is going to be removed and the lift is going to restarted.
- Remove the lockout/tagouts in the reverse order as the installation.
- Verify the proper operation of the equipment.
- Notify affected employees that the maintenance/service is completed and the machine is ready for operation.

15.0 EMERGENCY OPERATION:

If the lift becomes inoperative in the raised position, it is best to wait until the electrical power is restored before lowering the vehicle. However, if it's critical to safety that the lift be lowered, the following steps should be taken.



WARNING: DO NOT LOOSEN OR REMOVE HYDRAULIC CONNECTIONS OR FITTINGS UNDER PRESSURE. SERIOUS INJURY OR DEATH COULD OCCUR.

NOTE: Safely performing this process requires 3 people. All personnel should stay clear of the path of the lift. All tools and other non-secured items should be removed from the surface of the runways.

- 1) Survey the area surrounding the lift; remove any items and personnel from area before proceeding with this procedure.
- 2) Perform the appropriate lockout/tag out procedure on the electrical energy.
- 3) Use a second person standing at a safe distance away from the lift to keep watch on the area, lift, vehicle and other personnel throughout the process. This person should signal the person performing the procedure to stop if necessary.
- 4) Use a caution tape or similar to barrier the area around the lift to avoid personnel from accidentally entering the area while this process is being performed.
- 5) Do not proceed with this procedure if you are unfamiliar with the lift or its function.

15.1 IF THE MECHANICAL LOCKS ARE NOT ENGAGED:

- 1) Pull safety release lever simultaneously pressing the descent lever on the powerpack.
- 2) Keep a close eye on the movement of the lift and the position of the vehicle; release descent lever if any abnormal movement is detected.
- 3) Continue until the lift is fully lowered.
- 4) Once power is restored follow the lockout/tag out procedure to return the lift back into service.

15.2 IF THE MECHANICAL LOCKS ARE ENGAGED:

Various methods can be used to raise the lift in order to get sufficient clearance to disengage the mechanical locks. The safest method would employ temporary electrical power to the lift using a portable power generator. Any electrical connections should be done by a licensed electrician; lockout/tag out procedures should also be employed at this time.

This process should only be performed by a trained professional. Contact customer service or a local service professional for further assistance.

16.0 PARTS LIST

REPLACE WORN, DAMAGED OR BROKEN PARTS WITH PARTS APPROVED BY THE ORIGINAL EQUIPMENT MANUFACTURER ONLY

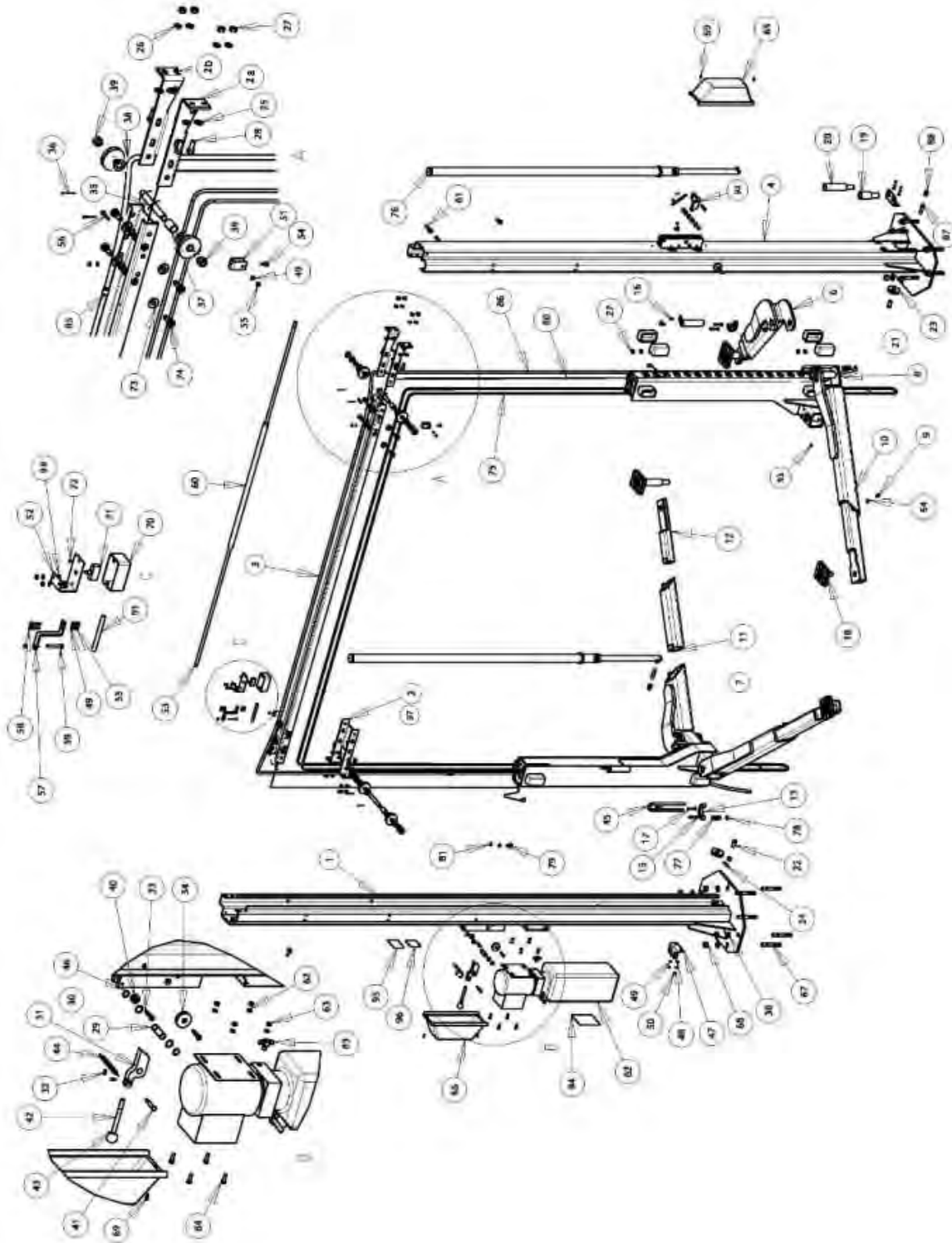

Item#	Part #	Description	Qty.
1	4-1010	Tower Weldment, Driver Side	1
2a	1-4066	Crossmember Bracket	1
2b	1-4065	Crossmember Bracket	1
3	2-2323	Crossmember Channel	1
4	4-1011	Tower Weldment, Passenger Side	1
5	4-1377	Carriage Weldment	2
6	2-2982	Outer Arm Weldment, Front RS	1
7	2-2981	Outer Arm Weldment, Front LS	1
8	3-1137	Outer Arm Weldment, Rear	2
9	6-0030	Hex Bolt, 3/8 UNC x 3/4" LG.	4
10	2-2968	Inner Arm Weldment, Rear	2
11	2-2282	Intermediate Arm Weldment, Front	2
12	2-2960	Inner Arm Weldment, Front	2
14	2-1594	Arm Pin	4
15	6-0295	Flat Washer, 5/16 I.D.	12
16	6-0423	Hex Bolt, 5/16"-18UNC x 3/4" LG.	4
17	6-2059	Hex HD. Bolt, 5/16-18UNC x 1 1/4" LG.	8
18	1-3278	Stack Pad Assembly	4
19 *	1-3280	Stack Pad Adapter 3"	2
20 *	2-1580	Stack Pad Adapter 6"	2
21	2-0772	Glide Block	8
22	1-1887	Pin, Cable Equalization	2
23	1-1898	2-Post Pulley	6
24	6-1841	Hitch Pin, 1/8" DIA.	2
25	6-0248	Flat Washer, 1/2" ID SAE	16
26	6-0059	Lock Washer, 1/2 "	16
27	6-0035	NUT, 1/2-13 UNC, HEX	16
28	6-0291	Hex Bolt, 1/2"-13 UNC x 1 1/2" LG.	8
29	1-2337	Safety Pin	2
30	6-0808	Flat Washer, 51/64" ID x 1" OD x 1/16" THK.	4
31	2-1901	Safety Dog Weldment, Power Side	2
32	6-0169	Self-Tapping Screw, #10 X 3/8 LG	6
33	6-0206	Shoulder Bolt, 3/8" DIA. X 1" LG.	3
34	1-0415	Safety Pulley	2
35	2-1251	Crossmember Pulley Shaft	2
36	6-0978	Cotter Pin, 1/8" DIA. X 1 1/2" LG.	4
37	1-1626	Crossmember Pulley Pipe, 1 3/4" LG.	2
38	6-0738	Flat Washer, 3/4" ID	26
40	1-1116	Safety Cable Pulley	3
41	6-0801	Shoulder Bolt, 3/8" x 1 1/2" LG.	2
42	1-1113	Safety Release Handle	1
43	6-1135	Plastic Knob	2
44	1-1115	Safety Spring	2
45	2-2942	Arm Lock Handle Weldment	4
46	6-2445	Snap Ring 3/4" EXT	4
47	1-2012	Stack Pad Adapter Holder	2

48	6-0060	Flat Washer, 1/4 I.D.	4
49	6-0056	Lock Washer, 1/4 I.D.	10
50	6-1353	Round HD. MACH. Screw 1/4-20 x 3/8" LG.	10
51	1-1378	Actuator Mounting Bracket	1
52	2-1143	Limit Switch Mounting Bracket	1
53	1-1380	Actuator Bar	1
54	6-0178	Hex Bolt, 1/4" x 3/4" LG.	1
55	6-0032	Hex Nut, 1/4-20UNC	7
56	6-0205	Hex HD. Bolt 1/4" NC x 1 1/2" LG.	1
57	1-1379	Actuator Extension	1
58	6-0027	Hex HD. Bolt 1/4" NC x 1 1/4" LG.	2
59	6-0741	Hex HD. Bolt 1/4"NC x 2" LG.	1
60	6-1404	Foam Guard	1
61	6-0069	Shoulder Bolt, 3/8" DIA. X 5/8" LG.	2
62	6-0674	Lock Washer, 5/16 I.D.	6
63	6-0294	Hex Nut, 5/16-18UNC	6
64	6-0062	Flat Washer, 3/8" ID SAE	4
65	0-0203	Safety Cover c/w Decals, Slave Side	1
66	0-0204	Safety Cover c/w Decals, Power Side	1
67	6-1379	Wedge Anchor 3/4 x 5 1/2" LG. (c/w Washers & Nuts)	10
68	6-0737	Hex Nut, 3/4"-10UNC	10
69	6-1134	SELF TAPPING SCREW, #12 X 1/2 LG	4
70	6-1403	Electrical Utility Box	1
71	6-0916	Microswitch	1
72	6-1466	6/32 Screw (Electrical Box)	2
73	6-0063	Flat Washer, 1/2	8
74	6-0045	Hex Bolt, 1/2-13UNC X 1" LG.	8
75	1-1786	Equalizing Cable	2
76	3-0621	Hydraulic Cylinder Assembly	2
77	1-4033	Arm Lock Spring	4
78	9-0114	Spring Pin, 4.5mm x 30mm	4
79	6-2074	Thimble, 5/32"	2
80	1-2058	Safety Release Cable	1
81	6-2055	Power Pack, 208-230 V, 1 PH	1
83	6-1506	Branch Tee	1
84	6-0293	Hex Bolt, 5/16"-18UNC x 1" LG.	4
85	6-1547	Tube Clamp, 5/8	8
86	2-1486	Hydraulic Hose (Long)	1
	2-1230	Hydraulic Hose (Short)	1
87	6-2095	Male Nipple, 1/4" NPT	2
88	6-1510	Flow Control	2

91	6-1173	Elec. Cable 12/3 x 117 LG.	1
92	2-0872	Safety Dog, Slave Side	1
93	6-0000	Grease Nipple	4
94	6-3039	Operations Decal	1
95	6-1767	Capacity Decal	1
96	6-1111	Serial Plate	1
97	2-2318	9K Symmetric Equalizing Pulley Assembly	2
98	6-0008	Hex Bolt, 1/4" x 1" LG.	2

* Stack Pad Adapters (3" and 6") do not come standard with the "D" series lift.
See Section 9.0 for available Accessories.

16.1 HYDRAULIC SYSTEM:

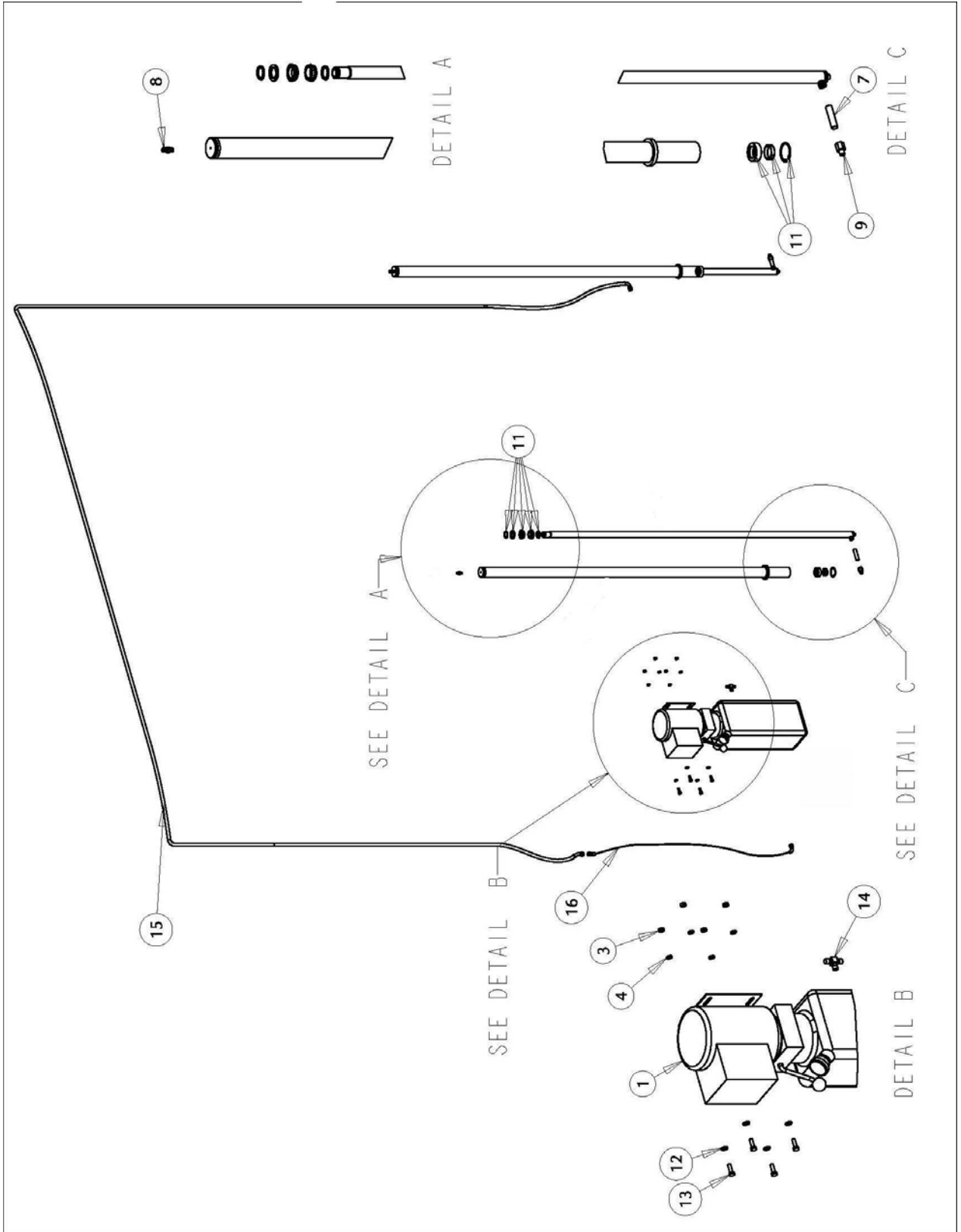

Item	Part #	Description	Qty
1	6-2055	Power Pack, 208-230V, 1 PH	1
	6-2665	Power Pack, 208-230V, 3 PH	
2	6-3039	"Lift Operation" Decal	1
3	6-0294	Hex Nut, 5/16"-18 UNC	4
4	6-0674	Lock Washer, 5/16" I.D.	4
7	6-2095	Male Nipple, 1/4" NPT	2
8	6-3666	Bleeder Valve (Holmac)	2
	6-4083	Bleeder Valve (HWF Eagle)	2
9	6-1510	Flow Control	2
11	6-3162	Gland & Piston Seal Kit (Holmac Cylinder)	2
	6-3914	Gland & Piston Seal Kit (HWF Eagle Cylinder)	2
12	6-0295	Flat Washer, 5/16" I.D.	4
13	6-0293	Hex Bolt, 5/16"-18 UNC x 1" LG.	4
14	6-1506	Branch Tee	1
15	2-1486	Hydraulic Hose (Long)	1
16	2-1230	Hydraulic Hose (Short)	1
	3-062101	Cylinder Assembly (Not INCL. Flow Control)	*
		3PH Power Pack Includes the Following (<i>Not Shown</i>)	
*	6-1575	Contactorm Box (Remove Jumper & Wire for 3PH)	1
*	2-1130	Contactorm Bracket	1
*	1-1369	Cover Plate	1
*	6-0008	Hex Bolt, 1/4" -NC x 1" LG	2
*	6-0056	Lock Washer, 1/4"	4
*	6-0032	Hex Nut, 1/4" - NC	2
*	6-0094	Strain Relief	2
*	8-0287	Cable, 14/4	2 ft

16.2 POWER PACK PARTS LIST:

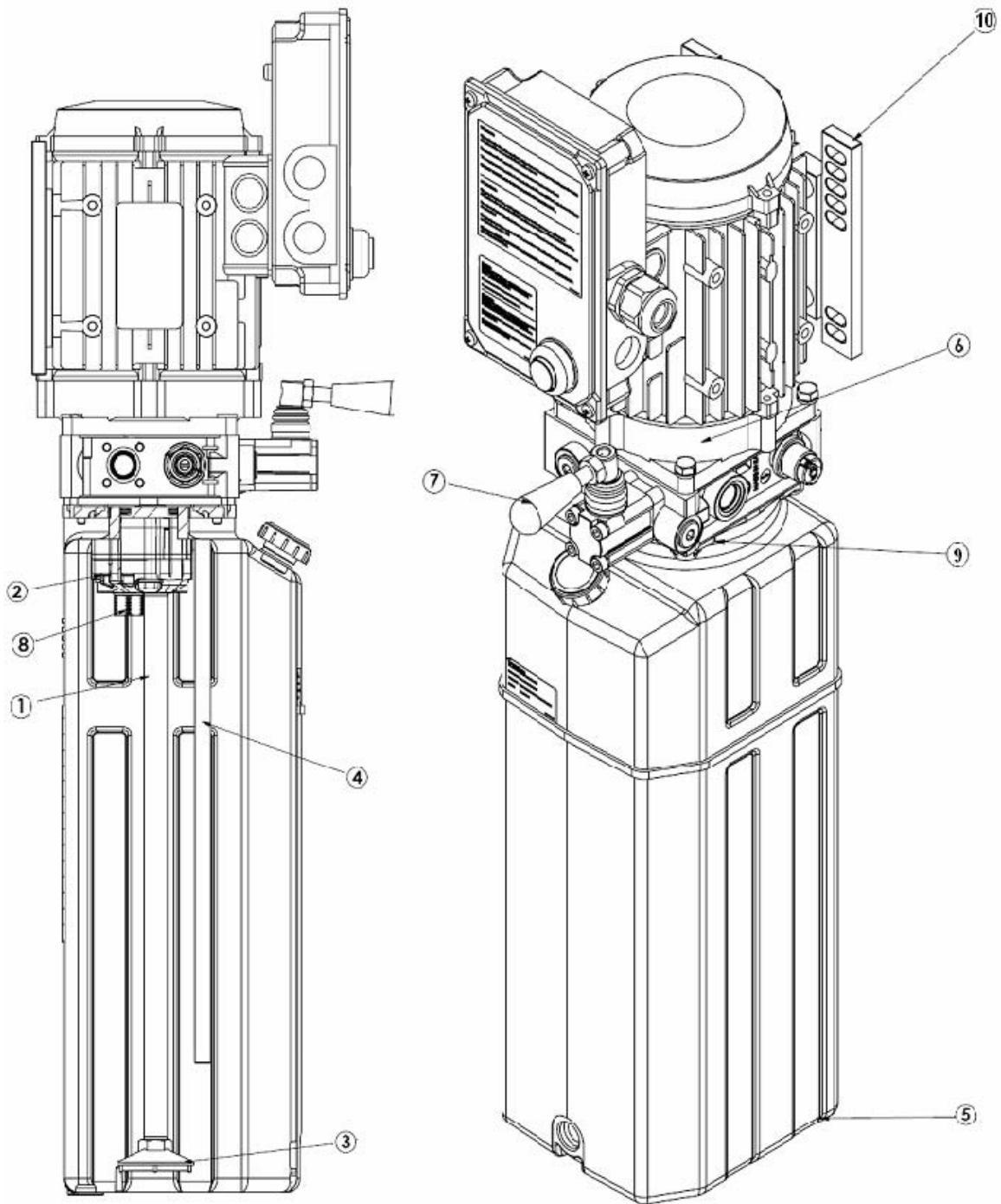











46.832.17.0004 230 V / 1 PH / 60 HZ

Item	Part #	Description	Qty
1	6-3442	PUMP 6.7G, 17 GEAR	1
2	6-3443	SUCTION PIPE 3/8"	1
3	6-3444	SUCTION FILTER 3/8" FEMALE 15 L/MIN	1
4	6-3445	RETURN PIPE	1
5	6-3446	PLASTIC TANK 12L	1
6	6-3447	MOTOR SHAFT COUPLING PUMP	1
7	6-3448	MANUAL VALVE	1
8	6-3452	START UP VALVE	1
9	6-3449	TANK BRACKET WITH SCREWS	1
10	6-3450	MOTOR BRACKETS	1
11*	6-3451	PUSH BUTTON WITH MICROSWITCH	1

***NOT SHOWN IN DIAGRAM**

17.0 AVAILABLE ACCESSORIES

Flip Pad Accessories				
	Poly Pad Adapter (set of 4)		High Lift Truck Extension Mid-Rise / 2-Post (set of 2)	
3000 lb max capacity each		2500 lb max capacity each		
Stack Pad Accessories				
	Stack Pad Adapter w/ Checker Plate Top (set of 4)		Stack Pad Ass'y w/ 3" & 6" Adapters (set of 1)	
3000 lb max capacity each		3000 lb max capacity each		
	1 1/2" Stack Pad Assembly Kit		4 1/2" Stack Adapter Kit	
3000 lb max capacity each		3000 lb max capacity each		
Common Accessories				
	Tool Tray Kit for 2-Post		Secondary Adapter Pad Kit (Used On Outer Arms)	
		3000 lb max capacity each		
	Air / Electric Service Station for 2-Post & 4-Post (90-110 psi 110 Volts Required)		Foam Door Protector Kit	
				24" Tower Extension

Accessories may not be available for all models. Contact supplier for availability and part numbers.

Max capacity is for 12,000 Lb Lifts. Do not exceed rated capacity of lift.