

SUN

INSTALLATION and OPERATION MANUAL



WHEELTRON

EELR113A EELR114A

(9000LB.)

EELR131A

(12,000 LB)

READ and SAVE THIS INSTRUCTION MANUAL

SUN is a trademark of
Snap-on Tools Corporation

1-800-268-7959

OCT 2005

6-1282

TABLE OF CONTENTS	PAGE
1. SAFETY INSTRUCTIONS.....	2
2. SPECIFICATIONS.....	3
3. CONTENTS.....	4
4. TOOLS REQUIRED FOR INSTALLATION	4
5. INSTALLATION INSTRUCTIONS.....	4
5.1 BAY LAYOUT	5
5.2 UNPACKING PROCEDURE.....	6
5.3 HYDRAULIC INSTALLATION.....	6
5.4 ELECTRICAL INSTALLATION.....	8
5.5 BLEEDING PROCEDURE	9
5.6 AIR LINE INSTALLATION	9
5.7 MECHANICAL SAFETY INSTALLATION:	10
5.8 LEVELING PROCEDURE.....	12
5.9 ANCHORING PROCEDURE:	13
5.10 INSTALLATION OF COVERS, WHEEL STOPS AND APPROACH RAMPS:.....	13
6. OPERATING INSTRUCTIONS	14
6.1 RAISING THE LIFT.....	14
6.2 LOWERING THE LIFT.....	15
7. RECOMMENDED MAINTENANCE	15
8. PARTS MANUAL.....	17
8.1 PARTS ASSEMBLY.....	18
PARTS LIST.....	19
8.2 HYDRAULICS.....	21
HYDRAULICS PARTS LIST.....	22
8.3 OPTIONS.....	23
OPTIONS PARTS LIST.....	24
8.4 9,000 LB POWER PACK ASSEMBLY.....	25
9,000 LB POWER PACK PARTS LIST.....	26
8.5 12,000 LB POWER PACK ASSEMBLY.....	28
12,000 LB POWER PACK PARTS LIST.....	29

1. SAFETY INSTRUCTIONS

When using this lift, basic safety precautions should always be followed, including the following:

1. Read all instructions in this manual and on the lift.
2. Inspect lift daily. Do not operate if it malfunctions or problems have been encountered.
3. Never attempt to overload the lift. The manufacturer's rated capacity is shown on the identification label on the power side column. Do not override the operating controls or the safety devices.
4. Only trained and authorized personnel should operate the lift. Do not allow customers or bystanders to operate the lift or be in the lift area.
5. **Caution! Never work under the lift unless the mechanical safety locks are engaged.**
6. Always keep the lift area free of obstruction and debris. Grease and oil spills should always be cleaned up immediately.
7. Never raise vehicle with passengers inside.
8. Before lowering check area for any obstructions.
9. To protect against the risk of fire, do not operate lift in the vicinity of open containers of flammable liquids.
10. Adequate ventilation should be provided when working on internal combustion engines.

SAVE THESE INSTRUCTIONS

2. SPECIFICATIONS

Maximum Capacity:

Overall Width:

Width Between Runways:

Overall Length (144" W/B):

Overall Length (155" W/B):

Overall Length (172" W/B):

Max. Raised Height:

Min. Lowered Height:

Lifting Time:

Power Requirements:

Shipping Weight (144" W/B):

Shipping Weight (172" W/B):

9000 lbs.	4100 kg	12000 lbs.	5450 kg
84"	2134 mm	92"	2337 mm
36"	914 mm	36"	914 mm
234"	5944mm	N/A	N/A
245"	6300mm	N/A	N/A
264"	6706 mm	264"	6706 mm
72"	1829 mm	72"	1829 mm
8 3/4"	222 mm	8 3/4"	222 mm
60 Sec.		60 Sec.	
230V, 1Ph, 60Hz		230V, 1Ph, 60Hz	
3450 lbs.	1565 kg	N/A	N/A
3560 lbs.	1615 kg	4980 lbs.	1615 kg

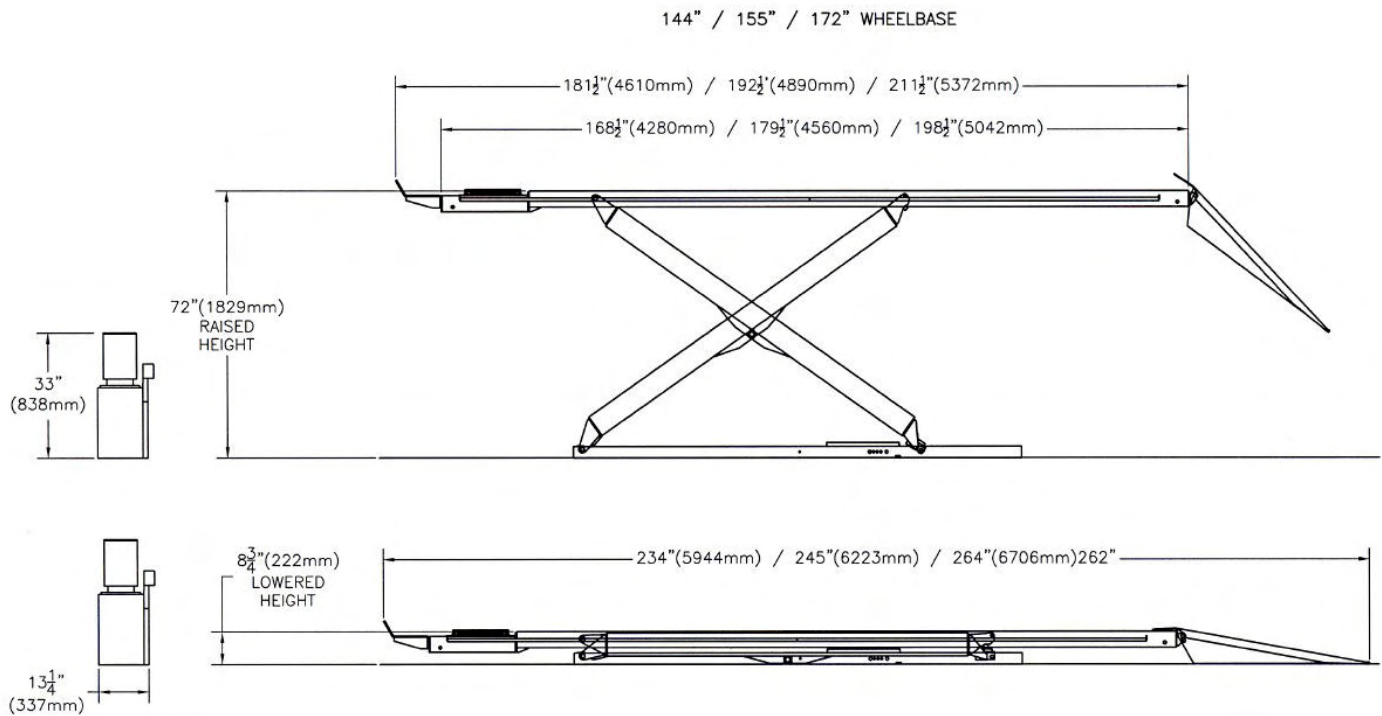

Figure 1 -Lift Dimensions

3. CONTENTS

The complete lift is contained in two (2) packages:

1. The **main structural components** are pre-assembled and packaged one on top of the other.
2. The remaining parts are packed in an **accessory box**.

Main Structural Components includes:

1pc. - Left Side Main Frame Assembly; Runway, Scissors and Base Frame

1pc. - Right Side Main Frame Assembly; Runway, Scissors and Base Frame

Note: Hydraulic lines in base frames have been factory installed

4. TOOLS REQUIRED FOR INSTALLATION

- * Rotary Hammer Drill or Similar, ¼" and ½" Concrete Drill Bits
- * 4' Level
- * SAE Wrenches and Sockets
- * Hammer
- * Pry Bar
- * Chalk Line
- * Tape Measure
- * Side Cutters
- * Screw Drivers
- * Hydraulic Fluid ISO 32 (10 weight hydraulic oil) - (20 liters / 5.3Gal.)

5. INSTALLATION INSTRUCTIONS

When the lift arrives on site, please read the owner's manual completely. Check the contents to make sure no parts are missing before starting installation. Gather all the tools listed and make sure the installation instructions are fully understood before commencing with the installation.

IMPORTANT: It is the user's responsibility to provide a satisfactory installation area for the lift. Lifts should only be installed on level concrete floors with a minimum thickness of five (5) inches or 130 mm. Concrete must have a minimum strength of 4000 psi or 30 MPa and should be aged thirty (30) days prior to installation. Please consult the architect, contractor or engineer if doubt exists as to the strength and feasibility of the floor to enable proper lift installation and operation.

It is the user's responsibility to provide all wiring for electrical hook-up prior to installation and to insure that the electrical installation conforms to local building codes. Where required, it is the user's responsibility to provide an electrical isolation switch located in close proximity to the lift that will enable emergency stop capability and isolate electrical power from the lift for any servicing requirements.

5.1 BAY LAYOUT

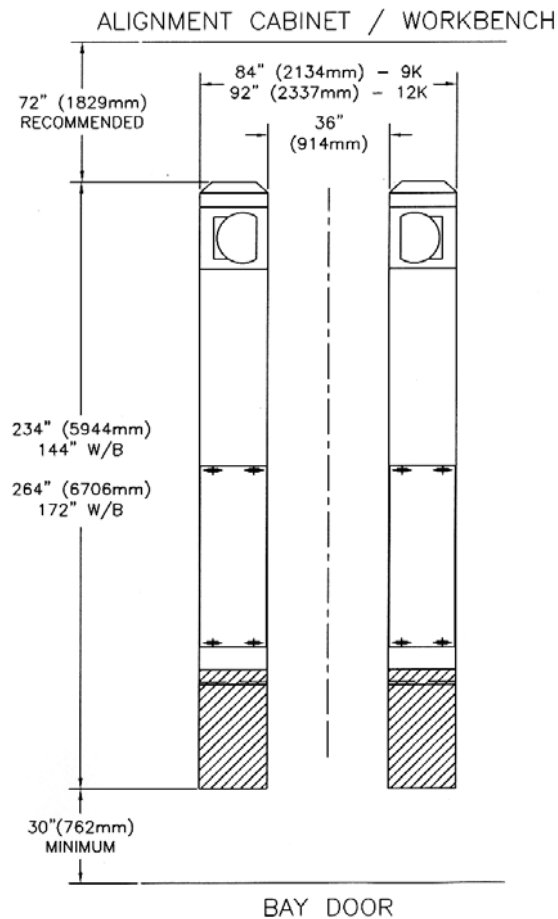

Figure 2 - Typical Bay Layout (Surface Mount)

IMPORTANT: DO NOT UNBOLT SHIPPING CLAMPS HOLDING EACH MAIN FRAME ASSEMBLY TOGETHER UNTIL INSTRUCTED TO DO SO.

1. After selecting the location best suited for your lift, draw a line parallel to the front of the lift, approximately 72" (1829mm) back from the cabinet/work bench area. This will be the approximate location of the front of the lift.

NOTE: Check the installation area for obstructions. (Overhead; light fixtures, heating ducts, ceiling, and In-ground; floor drains, electrical, etc.)

2. Mark on the floor an outline matching the dimensions listed.

144" (3658mm) W/B	Overall dimensions are 234" (5944mm) x 84" (2134mm).
172" (4369mm) W/B 9K	Overall dimensions are 264" (6706mm) x 84" (2134mm).
172" (4369mm) W/B 12K	Overall dimensions are 264" (6706mm) x 92" (2337mm).

3. Draw a center line down the middle of the outline starting at the front of the lift location and ending at the rear approach ramps.

4. Draw two lines parallel to the center line 18" (457mm) 9,000 lb. / 20" (508mm) 12,000 lb., on either side to locate the inside of the baseframes.
5. Draw a line parallel to the front of the lift or pit (flushmount) and align the front of each base frame assembly onto this line.

144" (3658mm) W/B 39" (991mm) back from the front of the lift
172" (4369mm) W/B 49" (1321mm) back from the front of the lift

6. Check the floor in the outline for the highest point using a four (4) foot level. Mark this location, reference will be made to it later during the leveling procedure.

5.2 UNPACKING PROCEDURE

Cut and remove the metal banding straps that hold the accessory box (and sliding Jack Beams if so equipped) and place in a convenient location near the installation area.

Cut and remove the metal banding straps surrounding the Two Main Frame Assemblies. Position the Main Frame Assemblies in the location previously marked in the bay layout.

NOTE: To distinguish between the left and right Main Frame Assemblies, ensure that the jack beam rails should be facing each other. All measurements are to be taken from the front of the lift.

Check that the inside of the base frames are 18" (457mm) away from the center line at both the front and rear of each mainframe assembly and that the front of each base frame is on the line drawn in step 5 of the bay layout Section 5.1.

5.3 HYDRAULIC INSTALLATION

NOTE: When working with hydraulics it is important to keep all components clean. All hydraulic connections are 37 ½° JIC flares.

1. Select a position best suited for the power pack.
2. Remove the breather filler cap and fill with 20 liters/5.3Gal. of ISO 32 hydraulic fluid (10 weight).
3. Connect the two (2) 21' (6401mm) long hydraulic hoses to the hydraulic outlet ports on the valve assembly of the power pack using the two 90deg elbows (3/8" JIC-M, 3/8" JIC-F) located in the hardware kit. Refer to Figure 3.
4. Locate the opposite ends of the two (2) 21' (6401mm) long hydraulic hoses. Connect to the two inlet ports of the lift, the inlet ports are located on the left side of the Left Main Frame Assembly. Refer to Figure 3.
5. Connect one end of the center hydraulic line to the outlet side of the Left Main Frame Assembly and the other end to the inlet side of the Right Main Frame Assembly. Tighten the hydraulic line in place so that it runs along the floor giving it a low profile.

IMPORTANT: THE SHIPPING CLAMPS HOLDING EACH MAIN FRAME ASSEMBLY TOGETHER MUST BE UNBOLTED BEFORE CONNECTING ELECTRICAL POWER. THERE ARE TWO (2) CLAMPS ON EACH ASSEMBLY.

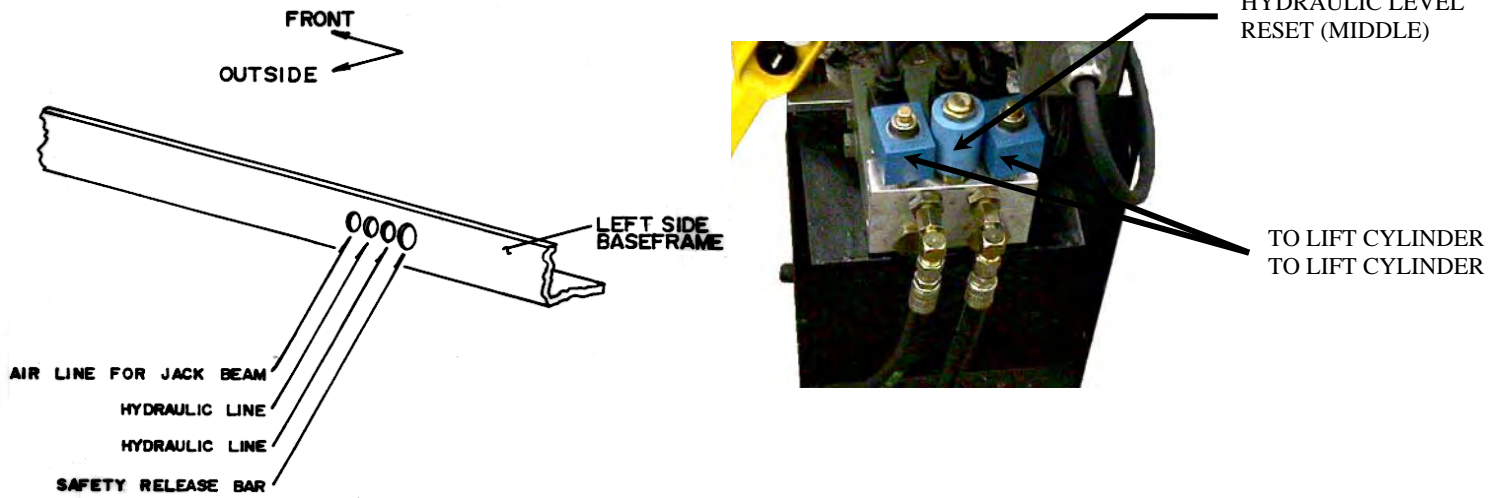
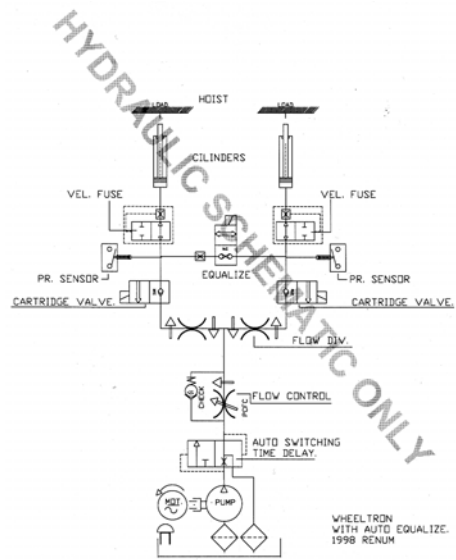

Figure 3 - Hydraulic Connections



Hydraulic Schematic

5.4 ELECTRICAL INSTALLATION

IMPORTANT: ALL FINAL ELECTRICAL CONNECTIONS SHOULD BE MADE BY A QUALIFIED ELECTRICIAN.

Please refer to Figure 4, the electrical diagram. Note: All electrical connections have been made and customer power supply can be connected using the 12" cable extending from the back of the contactor box.

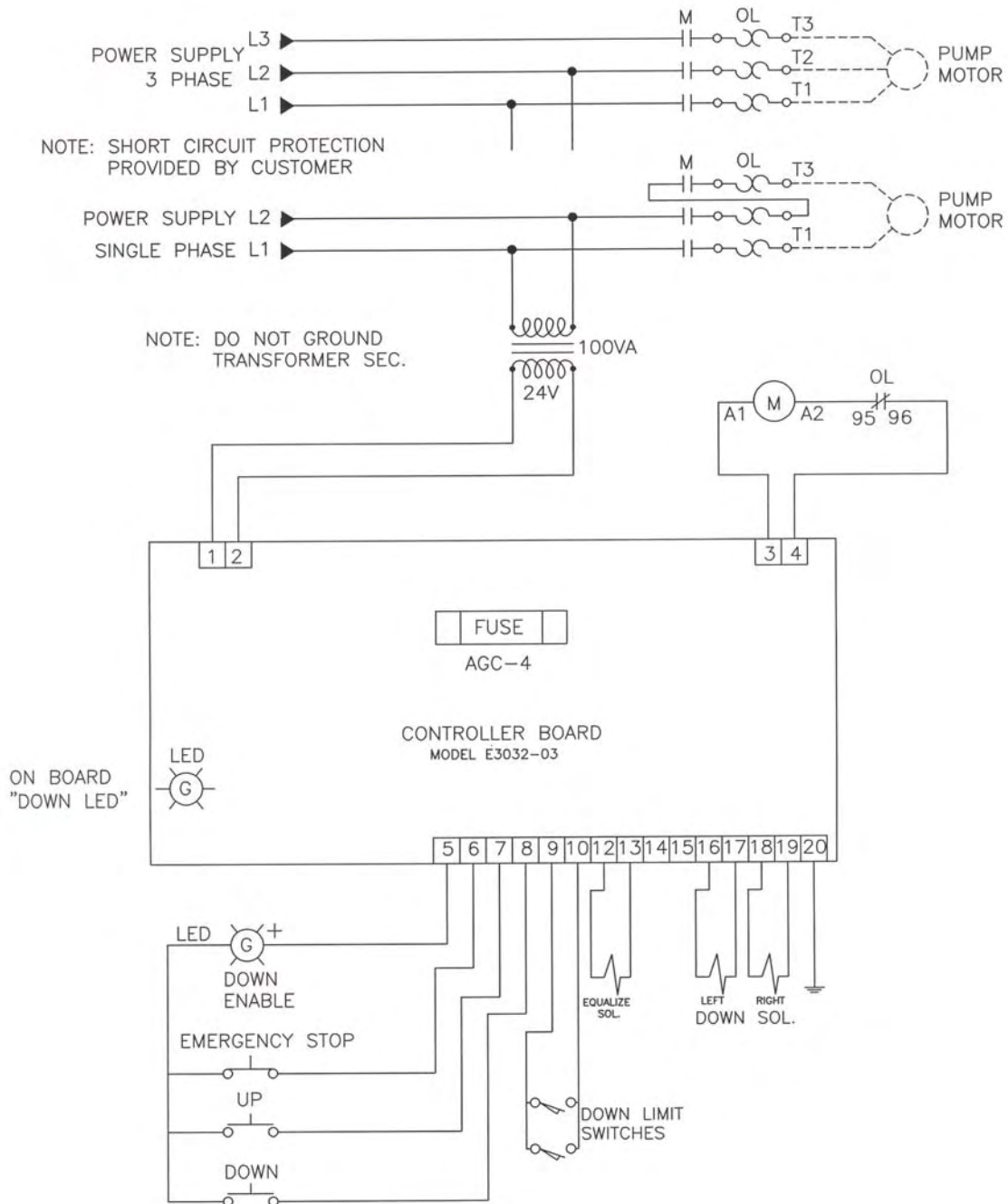

Figure 4 - Electrical Schematic; 220 Volt, 3Ph.

5.5 BLEEDING PROCEDURE

1. Once the main electrical power supply has been connected, turn the equalization adjustment fully clockwise. The equalization adjustment is located on the powerpack controller board, see Figure 4.
2. Press the up control button and raise the lift 10” (254mm) above the ground. If the LED does not illuminate, continue pressing the up button until the LED comes on.
3. Lower the lift to the ground and hold the down button until the LED light goes off. This will release air from the hydraulic system. Note: If the LED is not illuminated the lift will not lower – press the up button and raise the lift until the LED comes on. Once the LED is illuminated, the lift can be lowered.
4. Repeat these steps 3-4 times to completely bleed the system of air. Check the lift for hydraulic leaks at all connections. When complete, turn the equalization adjustment fully counter clockwise.
5. After bleeding, it is recommended that the filter assembly fitting (between the hydraulic hose and the powerpack – see Figure 3) be cleaned. Place the fitting on a workbench and use an air gun to blow through the filter in the opposite direction to flow from the lift.

5.6 AIR LINE INSTALLATION

1. Remove the air line fittings from the accessory box.
2. Raise the lift until the deck is at a suitable working height. Lower the lift until mechanical safety locks engage.
3. Assemble the fittings to the front of the right side deck as shown in Figure 5. Connect the 3/8” polytube from the inside of the deck to the fitting assembly.
4. Assemble the fittings to the rear of the right side deck as shown in Figure 5. Connect the 3/8” polytube from the inside of the deck to the fitting assembly.
5. Remove one recoil hose from the accessory box and connect it to the rear fitting assembly as shown in Figure 5. Run the recoil hose under the deck and connect the opposite end to the air line on the scissors using the 3/8”JIC-M x 1/4”NPT-F adapter from the hardware kit.
6. Connect the 21' (6401mm) long 3/8” braided hose (located in the accessory box) to the air inlet on the left baseframe.

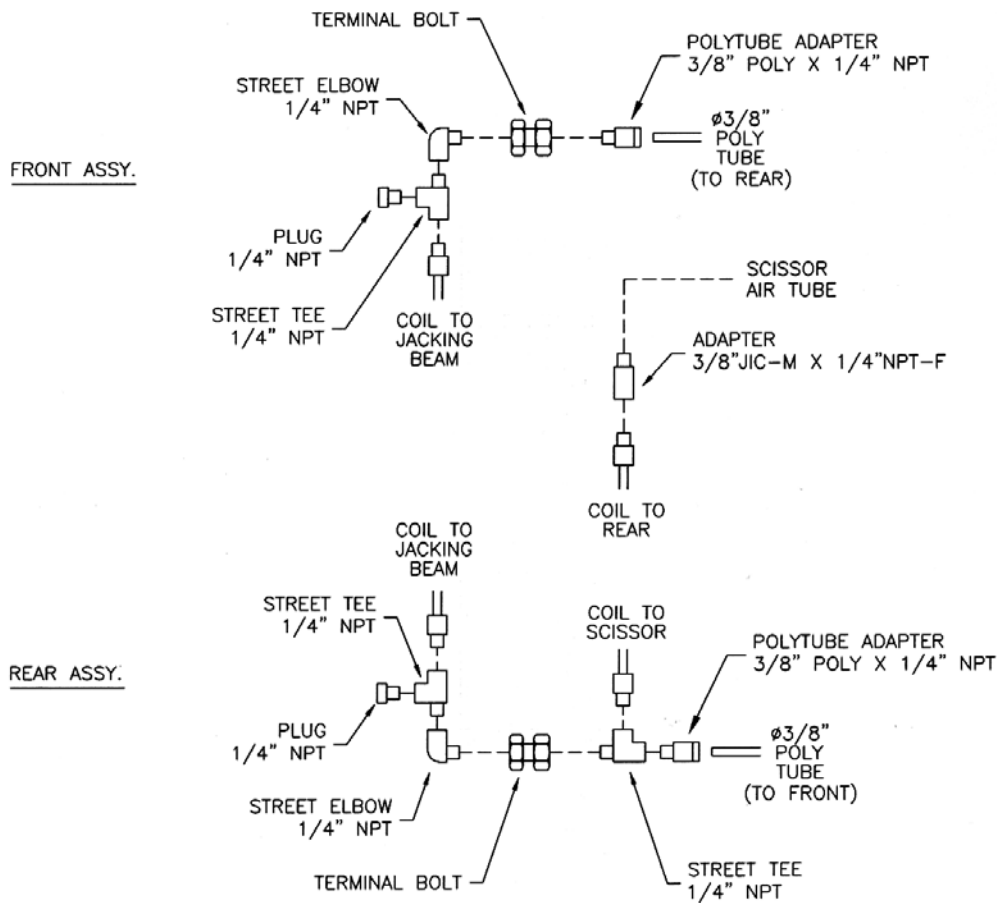

Figure 5 – Air Line Connections

5.7 MECHANICAL SAFETY INSTALLATION:

1. At this point, run the lift to full height and turn off the power supply to the power pack.
2. Slide each of the safety release rods through the holes closest to the rear of each baseframe.

NOTE: Install the rod with the flat section in the middle of the rod on top and pointing up toward the front of the deck when the slots on either end are parallel to the ground. Refer to Figure 6.

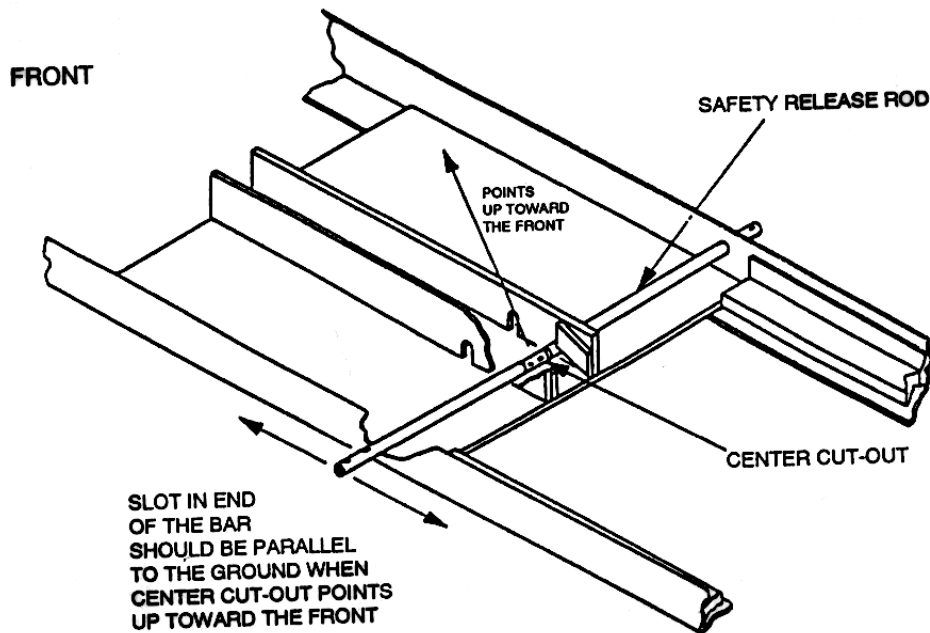

Figure 6 - Safety release rod location.

3. Install the rectangular safety release tab using two (1); 1/4" - 20UNC x 3/4"lg. cap screw and lock washers. The safety release tab bolts to the surface of the safety release rod located under the mechanical safety locks.
4. Install foot pedals on the outside of each safety release rod, using two (2); 1/4" - 20UNC x 1 1/4"LG. hex bolts, nuts and lockwashers for each pedal.
5. Install the foot pedal safety guards. The safety guards should be installed on each baseframe using the 1/4" - 20UNC x 3/4"LG. hex bolts and lockwashers provided.
6. Install the safety release connecting rod between the safety bars using 1/4" - 20UNC x 1 1/4" long hex bolt, nut and lockwasher, using one on each side.
7. Place the safety bar weldments back in their engaged position. **Turn power back on.**
8. Make sure there are no people, tools, or obstructions under the platforms before stepping on the safety pedal, then press down button on the control. Stop lowering at approximately 3 feet from the floor. Release the foot pedal and lower the lift down onto its safeties.
9. **FOR THOSE UNITS EQUIPPED WITH SLIDING JACK BEAM(S) NOW IS THE TIME TO INSTALL THE JACK(S).** Lower lift and consult instructions supplied with each Jacking Beam.
10. Turn on the shop air supply and check for leaks. The air supply line should have an operating pressure of 90-120psi (6-8bar).

5.8 LEVELING PROCEDURE

1. The highest point on the floor, noted from Section 5.1 step 6 is the point from which the base frame will be leveled from. Raise the lift to full height and, using a four (4) foot level across the base frames, verify again that this is the highest point.
2. Starting at the corner closest to the highest point, check along the length of the base frame edge with the four foot level and shim as required. **NOTE THE FIVE CRITICAL POSITIONS THAT SHIMS MUST BE PLACED ON EACH BASE FRAME OF EACH MAIN FRAME ASSEMBLY.** Refer to Figure 7.
3. Continue shimming across that base frame from side to side, and front to rear.
4. Once one frame is completely leveled, level the inside rails of the base frames to one another.
5. Now level the remaining outside half of the last base frame by placing the level across that unit and shimming as required.
6. A quick check across, along and between each base frame will ensure the leveling procedure was carried out successfully.

LEVELING EXAMPLE:

Assuming that the front right corner is the highest point level in the following order:

- Shim along side "A"
- Shim across from side "A" to side "B" (check along side "B" from front to back)

The Right Side base frame should now be leveled.

- Shim across from side "B" to side "C" (check along side "C" from front to back)
- Shim across from side "C" to side "D" (check along side "D" from front to back)
- Shim along side E & side F (locking Mechanism)

Both base frames should now be leveled from front to back and side to side.

NOTE: Base frame leveling should be performed as a reference before main leveling of the decks. One last check before anchoring is to make sure that there is 36" between the baseframes.

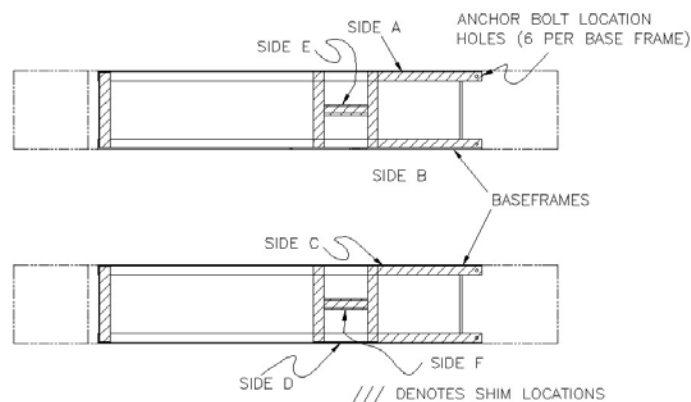

Figure 7 - Leveling Procedure Example

5.9 ANCHORING PROCEDURE:

NOTE: Check operation of lift (up/down) and movement of jack beams before anchoring the lift

1. Using a rotary hammer drill and a ½" concrete drill bit, drill through the floor in the six (6) anchor bolt locations on each of the base frames. Make sure that the ½" concrete drill is in good condition. Refer to Figure 8.
2. Insert the ½" x 4 ½" long wedge anchor bolts supplied, place a flat washer and nut on each anchor. Tighten securely.
3. Torque all anchor bolts to 55 ft. lbs.
4. With all anchor bolts torqued as specified operate the lift checking its full operation.

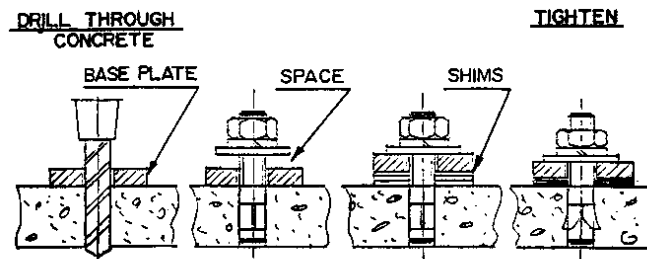

Figure 8 - Anchoring

5.10 INSTALLATION OF COVERS, WHEEL STOPS AND APPROACH RAMP:

1. Locate and install the center cover over the mechanical safety release connecting rod and center connecting hydraulic line. Install using the four (4) ¼" - 20 UNC x ¾" long hex head bolts, flat washers and lock washers.
2. Check to make sure that the safety release connecting rod does not bind during operation.
3. Locate and install protective line covers over all air and hydraulic supply lines.
4. Using a rotary hammer drill and a ¼" concrete drill bit, drill all line cover locations. Using the ¼" nail-in anchors supplied, fasten the line covers to the floor.
5. Locate and install the two (2) front wheel stops; one (1) to the front of each of the runways using the six (6) 1/2" - 13 UNC x 1 1/2" long hex head bolts, flat washers, and lock washers.
6. Install the approach ramps using ramp pins, washers, and cotter pins.

6. OPERATING INSTRUCTIONS

NOTE: In case of power failure, the manual override can be used to lower the lift. To operate the manual override, first remove red plastic tamper proof cap from each of the two solenoids connected to the hydraulic lines. Unscrew the center needle valves on each of these 2 solenoids simultaneously to the fully counterclockwise position. The lift will then lower to the ground (Note: a second person may be required to disengage the safeties).

6.1 RAISING THE LIFT

1. If the lift is equipped with Sliding Jack Beam(s) be sure that the Beam(s) are positioned at the front or mid travel of the lift, fully down, with the risers removed and stored. Never store Jack Beam(s) at the rear of the lift.
2. Be sure that the lift is fully lowered before attempting to load or unload a vehicle.
3. Position the vehicle on the lift ensuring the resulting load on each deck is distributed as evenly as possible.

NOTE: The vehicle is positioned correctly when the distance from the center of the tires to the inside edge of the runways is equal on both runways, for the front and rear tires.

4. Check that there are no obstructions above the lift that could damage the lift or vehicles.
5. Raise the lift by pressing the up button on the remote pendant control. Raise the lift up past the desired working height until the mechanical safety drops into position. Press the down button to lower the lift down onto both of the mechanical safeties. Note: If the LED is not illuminated the lift will not lower – press the up button and raise the lift until the LED comes on. Once the LED is illuminated, the lift can be lowered.
6. Continue depressing down button until L.E.D. shuts off. (To allow lift to equalize automatically)

NOTE: NEVER WORK UNDER A VEHICLE OR THE LIFT UNLESS IT IS POSITIONED ON BOTH MECHANICAL SAFETIES!

6.2 LOWERING THE LIFT

1. Check that there are no obstructions under the lift or vehicle. Be sure that the Sliding Jack Beams are fully lowered and positioned at the front or mid section of the lift.
2. Raise the lift by pressing the up button until the mechanical safety bars are off their stops, and the LED light illuminates. Stop raising.
3. Depress the safety release pedal to disengage the mechanical safety locking bars. Continue to hold the pedal while depressing the down button on the remote pendant control.
4. Continue lowering until the lift is approximately 34" (864mm) above the floor. Then release the mechanical safety release pedal, allowing the mechanical safety locking bars to be reset for their next use. Continue to depress the down button until the lift is completely lowered and LED light goes off for leveling of both runways.

NOTE: The operator must always keep their attention on the operation of the lift while raising or lowering.

5. Be sure that the lift is completely lowered before removing the vehicle from the lift.

7. RECOMMENDED MAINTENANCE

1. The lift should be greased at least once every two months. There are six (6) points on each lift that will take grease: four (4) on the scissors hinges and one on each of the two (2) hydraulic cylinder rod eyelet's.
2. The fluid level in the reservoir should be checked periodically. Be sure that the lift is fully lowered when checking. The hydraulic fluids should be changed once every five years. Use only ISO 32 hydraulic fluid.
3. The roller tracks should always be kept clean and free of debris. This area should be checked before any raising or lowering of the lift.
4. Inspect the operation of the lift daily. Raise and lower fully.
5. Inspect electrical and mechanical operations of all switches, electrical and mechanical.
6. Lifts equipped with full floating rear slip plates and front radius turning plates, require to be disassembled and cleaned once every 3 months. More frequently with lifts that are in areas with more exposure to sand and salt.

NOTE: Locking pins should always be installed on front and rear plates before attempting to drive a vehicle on or off the lift.

QUARTELY REAR SLIP PLATE MAINTENANCE

1. Remove top Slip Plate covers by first removing the four (4) shoulder bolts on each cover.
2. Remove polyethylene bearing cages insuring that all the delrin bearings remain in the cages. Additional delrin bearings may be purchased if required.
3. Clean runway surface and touch up any paint wear with a rust resistant paint. Allow paint to dry thoroughly.
4. To obtain optimum performance, the position of the slip plate bearing cage should be rotated every quarter to change the wear pattern. With the first quarter maintenance, flip the bearing cage over to the opposite side. With the second quarter maintenance, rotate the bearing cage end-to-end. With the third quarter maintenance, flip bearing cage over to the opposite side. Fourth quarter maintenance should see the bearing cage rotated back to the position it started in.
5. Quarterly maintenance will optimize performance and contribute to longer slip plate life.

8. PARTS MANUAL WHEELTRON ASSEMBLY

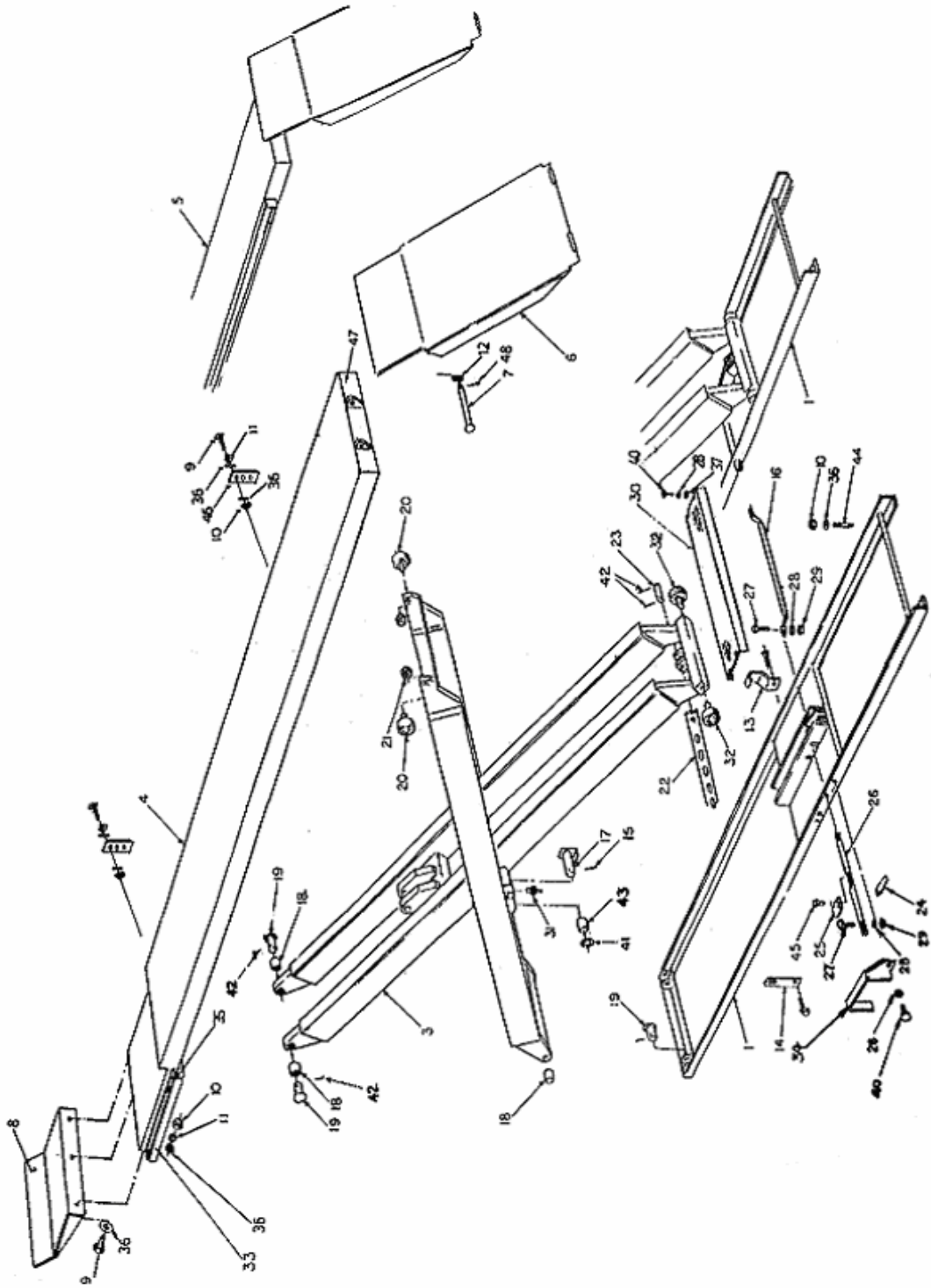

WHEELTRON - PART LIST

ITEM	QTY.	DESCRIPTION	PART #
1	2	BASE FRAME WELDMENT, 9K	4-0160
	2	BASE FRAME WELDMENT, 12K	4-0160
3	2	SCISSOR WELDMENT	4-0002
4	1	9K ALIGNMENT DECK, LEFT SIDE (144"W/B)	4-0379
	1	9K ALIGNMENT DECK, LEFT SIDE (155"W/B)	4-1071
	1	9K ALIGNMENT DECK, LEFT SIDE (172"W/B)	4-0415
	1	12K ALIGNMENT DECK, LEFT SIDE (172"W/B)	4-0158
5	1	9K ALIGNMENT DECK, RIGHT SIDE (144"W/B)	4-0380
	1	9K ALIGNMENT DECK, RIGHT SIDE (155"W/B)	4-1070
	1	9K ALIGNMENT DECK, RIGHT SIDE (172"W/B)	4-0416
	1	12K ALIGNMENT DECK, RIGHT SIDE (172"W/B)	4-0159
6	2	RAMP ASSEMBLY W/ ROLLER	3-0905
7	4	RAMP PIN	1-1887
8	2	FRONT WHEEL STOP	2-0851
9	6	HEX BOLT, 1/2" - 13UNC X 1 1/2"LG.	6-0291
10	18	HEX NUT, 1/2" - 13UNC	6-0035
11	6	LOCK WASHER, 1/2" I.D.	6-0059
12	4	3/4" I.D. FLAT WASHER	6-0738
13	2	SHIPPING BRACKET	2-0112
14	2	FLAT SHIPPING BRACKET	2-0266
15	4	SPRING PIN, 3/16" X 2" LG.	6-0146
16	1	SAFETY RELEASE CONNECTING ROD	2-0071
17	4	FULCRUM PIN, 1 1/4" DIA.	1-0106
18	8	BUSHING, 1" I.D.	6-0085
19	8	END HINGE PIN, 1" DIA.	1-0107
20	4	CAM FOLLOWER	6-0637
21	4	JAM NUT, 5/8" - 18UNF	6-0040
22	2	SAFETY BAR WELDMENT	2-1683
23	2	SAFETY PIN	1-0547
24	2	SAFETY PEDAL (9K)	2-0194
	2	SAFETY PEDAL (12)	2-0742
25	2	SAFETY RELEASE TAB	1-2169
26	2	SAFETY RELEASE ROD (9K)	2-2133
	2	SAFETY RELEASE ROD (12K)	2-2134
27	6	HEX BOLT, 1/4" - 20UNC X 1 1/4" LG.	6-0027
28	14	LOCK WASHER, 1/4" I.D.	6-0056
29	6	HEX NUT, 1/4" - 20UNC	6-0032
30	1	CENTER COVER (9K)	3-0365
	1	CENTER COVER (12K)	3-0371
31	4	GREASE NIPPLE	6-0000
32	4	CAM FOLLOWER	6-0077
33	2	PULL OUT STEP ASSEMBLY	2-0362
		* NO PULL OUT STEP ASSEMBLY FOR 12K MODEL	
34	2	TOE GUARD (9K)	1-0086
	2	TOE GUARD (12K)	1-0698
35	2	SAFETY WALK TAPE	1-0749
36	24	PLAIN WASHER, 1/2" I.D.	6-0063
37	4	FLATWASHER, 1/4" I.D.	6-0060
40	8	HEX BOLT, 1/4" - 20UNC X 3/4" LG.	6-0178

ITEM	QTY.	DESCRIPTION	PART #
41	4	WASHER	1-0140
42	14	COTTER PIN, 1/8" X 2"LG.	6-0115
43	4	BUSHING, 1 1/4" I.D.	6-0084
44	12	9K WEDGE ANCHOR, 1/2" X 4 1/2" LG.	6-0140
	16	12K WEDGE ANCHOR, 1/2" X 4 1/2" LG.	6-0140
45	2	FLAT HD., 1/4"-20UNC X 3/4" LG	6-1086
46	2	T/B BRACKET (12K) FOR AIR KIT, D.S. ONLY	1-0636
	2	HEX BOLT, 1/2" - 13UNC X 1 1/2" LG.	6-0291
	2	HEX NUT, 1/2" - 13UNC	6-0035
	4	PLAIN WASHER, 1/2" I.D.	6-0063
	2	LOCK WASHER, 1/2" I.D.	6-0059
47	2	ADAPTER PLATE (12K)	1-2319
	6	HEX BOLT, 1/2" - 13UNC X 1 1/2" LG.	6-0291
	6	HEX NUT, 1/2" - 13UNC	6-0035
	12	PLAIN WASHER, 1/2" I.D.	6-0063
	6	LOCK WASHER, 1/2" I.D.	6-0059
48	4	COTTER PIN 1/8" X 1 1/2"	6-0978

WHEELTRON HYDRAULICS

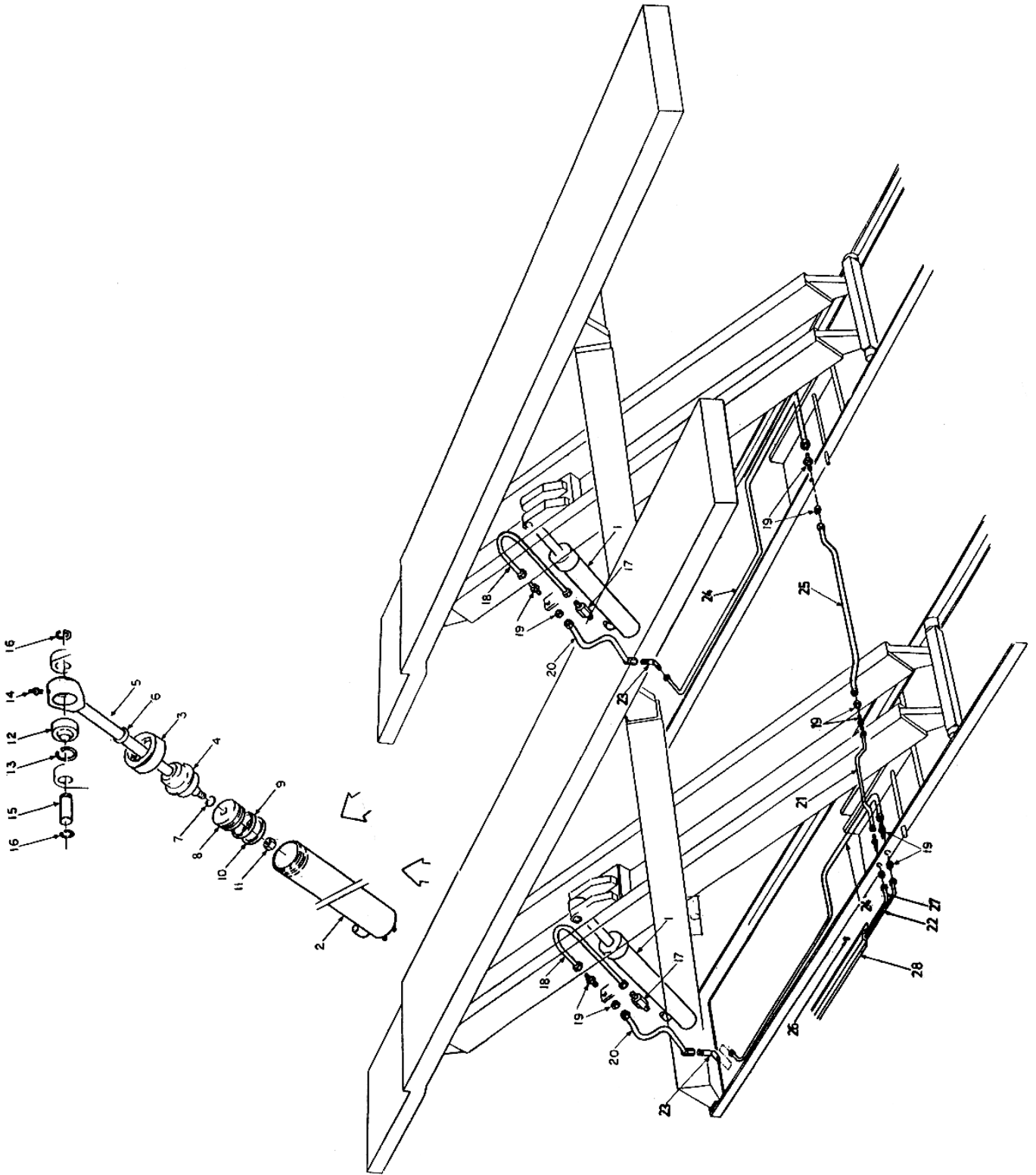

WHEELTRON - HYDRAULICS PART LIST

ITEM	QTY.	DESCRIPTION	PART #
1	2	HYDRAULIC CYLINDER	3-0000
1-2	1	TUBE WELDMENT	2-0000
1-3	1	NUT GLAND	1-0011
1-4	1	GLAND	1-0008
1-5	1	ROD WELDMENT	2-0001
1-6*	1	WIPER RING	6-0001
1-7*	1	'O' RING	6-0002
1-8	1	PISTON	1-0007
1-9*	1	SEAL RING	6-0003
1-10*	1	WEAR RING	6-0004
1-11	1	NYLON INSERT LOCK NUT, 7/8"-14UNF	6-0005
1-12	1	BEARING	6-0007
1-13	1	RETAINING RING	6-0070
1-14	1	GREASE NIPPLE	6-0000
15	2	PIN	1-0029
16	4	RETAINING RING	6-0340
17	2	VELOCITY FUSE	6-0422
18	2	TUBE ASSEMBLY, CYLINDER	1-0093
19	6	BULKHEAD, CONNECTOR 3/8"JIC C/W JAM NUT	6-0013
20	2	HOSE ASSEMBLY	2-2136
21	1	TUBE ASSEMBLY	2-0848
22	1	HYDRAULIC HOSE ASSEMBLY	2-2050
23	2	BULKHEAD, 90° ELBOW 3/8"JIC M C/W JAM NUT	6-0012
24	2	TUBE ASSEMBLY	2-0849
25	1	TUBE ASSEMBLY (9K)	2-0065
	1	TUBE ASSEMBLY (12K)	2-0519
26	20	CONCRETE NAIL, 1/4" x 1"	6-0141
27	1	HYDRAULIC HOSE ASSEMBLY	2-1049
28	5	LINE COVER	2-1104

*HYDRAULIC CYLINDER SEAL KIT PART # 0-0007

WHEELTRON OPTIONS

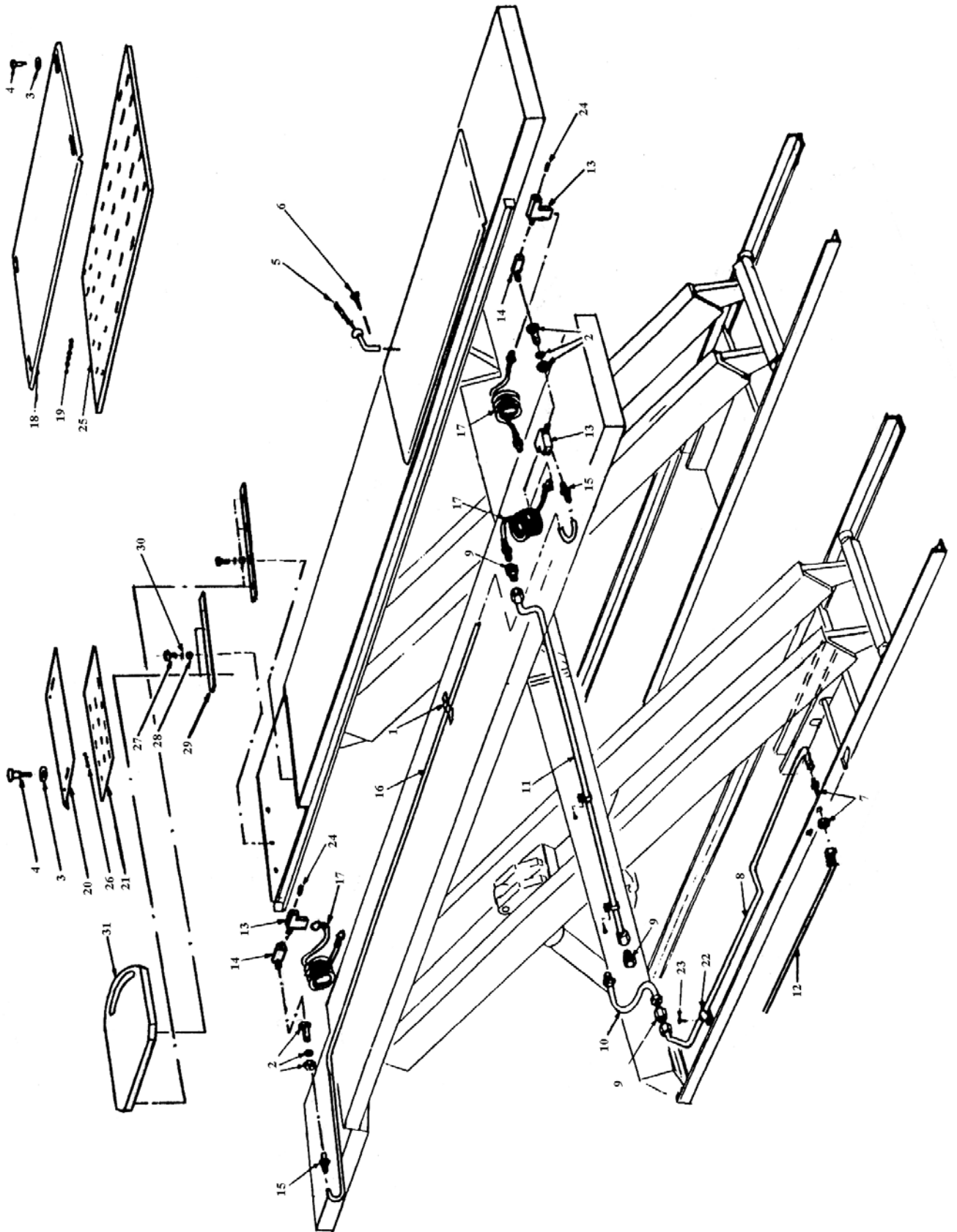

WHEELTRON - OPTIONS PART LIST

ITEM	QTY.	DESCRIPTION	PART #
1	5	FRAME CLIP	6-0500
2	2	TERMINAL BOLT, 3/4"-16m W/1/4 NPT F	6-0167
3	12	FLAT WASHER	6-0426
4	12	SHOULDER BOLT, 3/8" X 5/8"LG.	6-0069
5	8	LOCKING PIN ASSEMBLY	2-2184
6	8	SELF TAP SCREW #10 X 1/2"LG.	6-0505
7	1	BULKHEAD, CONNECTOR 3/8"JIC C/W JAM NUT	6-0013
8	1	TUBE ASSEMBLY	3-0017
9	3	ADAPTER, 3/8"JIC M TO 1/4"NPT F	6-0118
10	1	HOSE ASSEMBLY	1-0119
11	1	TUBE ASSEMBLY	2-0062
12	1	3/8"DIA. PVC BRAIDED HOSE, 22'LG. (C/W FITTINGS)	6-1345
13	3	STREET TEE 1/4"NPT	6-0014
14	2	STREET ELBOW	6-0015
15	2	POLYTUBE STRAIGHT ADAPTER, 3/8" X 1/4"NPT	6-0710
16	1	HOSE 144"W/B	1-0120
17	3	12' COILED HOSE	6-0337
18	2	REAR SLIP PLATE WELDMENT	3-0197
19	1 SET (225)	BALL BEARING, 1/4"DIA.	6-0829
20	2	FRONT POSITIONING PLATE WELDMENT	2-0841
21	2	FRONT BEARING CAGE	1-1070
22	4	TUBE CLAMP	6-0170
23	4	SELF TAP SCREW, #10 X 3/8"LG.	6-0169
24	2	PLUG, 1/4"NPT	6-0282
25	2	REAR BEARING CAGE	3-0196
26	1 SET (70)	BALL BEARING, 1/4" DIA.	6-0829
27	16	HEX HD. BOLT, 1/4"-20UNC X 3/4"LG.	6-0178
28	16	FLATWASHER, 1/4" I.D. x 3/4"OD, PLATED	6-0060
29	4	RETAINING BAR	2-1391
30	16	LOCKWASHER, 1/4"DIA.	6-0056
31	2	WHEELTRON TURNPLATE	4-0375

9,000 LB WHEELTRON POWER PACK

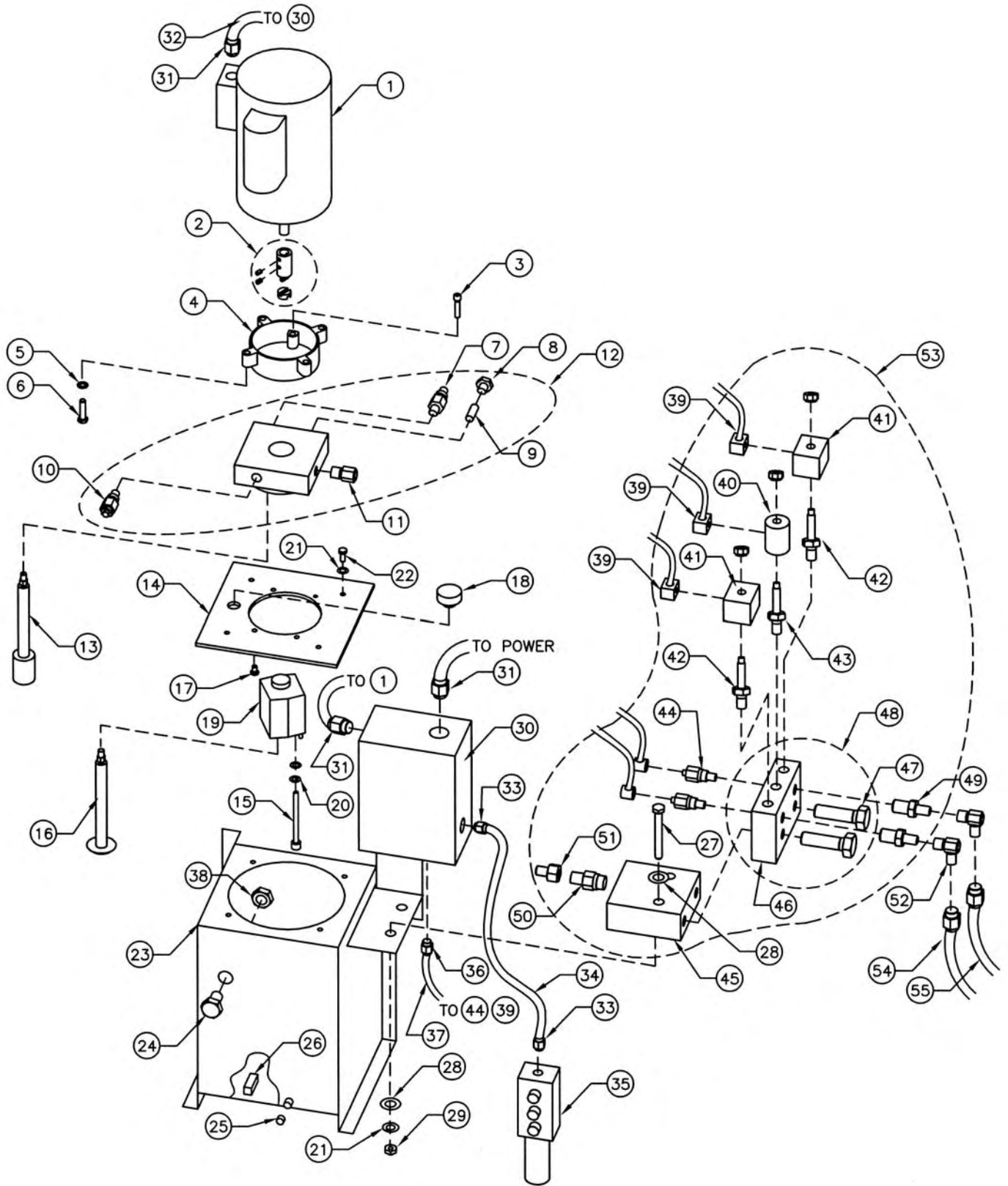

9,000 LB WHEELTRON POWER PACK - PARTS LIST

ITEM NO.	QTY.	DESCRIPTION	PART NO.
1A	1	MOTOR, 220V, 1 PHASE	6-0087
1B	1	MOTOR, 220V, 3 PHASE	6-0446
1C	1	MOTOR, 575V, 3 PHASE	6-0447
2	1	MOTOR COUPLER	6-2537
3	2	CAP SCREW, SOCKETHEAD, 5/16"-18UNC x 1 1/2" LG	6-2534
4	1	BELLHOUSING	6-2507
5	4	LOCKWASHER, INTERNAL TOOTH, 3/8"	6-2547
6	4	CAP SCREW, HEX HEAD, 3/8"-16UNC x 1 1/2" LG	6-2558
7	1	AUTO SWITCHING VALVE	6-2273
8	1	PLUG, 3/8" (INCLUDES "O"-RING)	6-2519
9	1	FLOW CONTROL , 1.5 – 2 GPM	6-2272
10	1	RELIEF VALVE (4100 PSI)	6-2264
11	1	SWIVEL ADAPTER (1/4" NPT MALE TO 3/8" JIC	6-2270
12	1	MAIN BODY ASSEMBLY (INCLUDES 7,8,9,10,11)	6-2545
13	1	RETURN FILTER ASSEMBLY	6-2546
14	1	MOUNTING PLATE	6-2521
15	2	CAP SCREW, SOCKET HEAD, 5/16"-18UNC x 3 1/4" LG	6-2536
16	1	INLET STRAINER ASSEMBLY	6-2535
17	4	CAP SCREW, BUTTIONHEAD, 5/16"-18UNC x 1/2" LG	6-2524
18	1	FILLER / BREATHER CAP	6-2523
19	1	PUMP	6-2268
20	4	LOCKWASHER, 5/16"	6-0674
21	4	LOCK WASHER, 1/4"	6-0056
22	4	CAP SCREW, HEX HEAD, 1/4"-20UNC x 3/4" LG	6-0178
23	1	OIL RESERVOIR	4-0740
24	1	OIL LEVEL SIGHT PLUG	6-0517
25	1	PLUG, SOCKETHEAD, 3/8" NPT	6-0102
26	1	MAGNET	6-0405
27	2	CAP SCREW, HEX HEAD, 1/4"-20 UNC x 2 3/4" LG	6-0648
28	4	FLAT WASHER, 1/4"	6-0060
29	4	NUT, HEX, 1/4"-20UNC	6-0032
30A	1	CONTACTOR ASSEMBLY, 220V, 1PH INCLUDES:	
	1	PRINTED CIRCUIT BOARD	6-2125
	2	FUSE 2A 600V	6-2178
	1	CONTACTOR BOX, 1 PH, 24V COIL	6-2148
	1	TRANSFORMER, 220V	6-2126
30B	1	CONTACTOR ASSEMBLY, 220V, 3 PHASE INCLUDES:	
	1	PRINTED CIRCUIT BOARD	6-2125
	2	FUSE 2A 600V	6-2178
	1	CONTACTOR BOX, 3 PH, 24V COIL	6-2120
	1	TRANSFORMER, 220V	6-2126
	1	THERMAL OVERLOAD, 6 – 9.2A	6-2176

30C	1	CONTACTOR ASSEMBLY, 460V, 3 PHASE INCLUDES:	
	1	PRINTED CIRCUIT BOARD	6-2125
	2	FUSE 2A 600V	6-2178
	1	CONTACTOR BOX, 3 PH, 24V COIL	6-2120
	1	TRANSFORMER, 460V	6-2171
	1	THERMAL OVERLOAD, 2.7 – 4.2A	6-2175
30D	1	CONTACTOR ASSEMBLY, 575V, 3 PHASE INCLUDES:	
	1	PRINTED CIRCUIT BOARD	6-2125
	2	FUSE 2A 600V	6-2178
	1	CONTACTOR BOX, 3 PH, 24V COIL	6-2120
	1	TRANSFORMER, 575V	6-2147
	1	THERMAL OVERLOAD, 1.8 – 2.8A	6-2174
31A	3	½” STRAIN RELIEF CONNECTOR (1 PHASE)	6-1370
31B	3	½” STRAIN RELIEF CONNECTOR (3 PHASE)	6-0094
32A	1	MOTOR CABLE (1 PHASE)	1-0104
32B	1	MOTOR CABLE (3 PHASE)	1-1824
33	1	3/8” STRAIN RELIEF CONNECTOR	6-0093
34	1	REMOTE CONTROL CABLE	6-1989
35	1	REMOTE HAND CONTROL, 2 BUTTON W/ LED	6-2038
36	5	¼” STRAIN RELIEF CONNECTOR	6-0092
37	15 FT	COIL / PRESSURE SWITCH CABLE	8-0306
38	5	½” CONDUIT LOCKNUT	6-1610
39	3	DIN CONNECTOR (24V)	6-2236
40	1	ROUND COIL (24V)	6-2114
41	2	SQUARE COIL (24V)	6-2128
42	2	SPOOL VALVE (C/W MANUAL OVERRIDE)	6-2129
43	1	SPOOL VALVE (RESQUARE)	6-1364
44	2	PRESSURE SWITCH (INCLUDES BONDED SEAL)	6-2548
45	1	FLOW DIVIDER	6-2549
46	1	MANIFOLD	6-2551
47	2	BANJO BOLT (INCLUDES BONDED SEAL)	6-2550
48	1	MANIFOLD ASSEMBLY (INCLUDES 46-47)	6-2552
49	2	FILTER FITTING (BSP 3/8” MALE TO 3/8” JIC MALE)	6-2127
50	1	FILTER FITTING (BSP ½” MALE TO 3/8” JIC MALE)	6-2553
51	1	ADAPTER (3/8” JIC MALE TO 3/8” JIC FEMALE W/	6-2559
52	2	90° ELBOW (3/8” JIC MALE TO 3/8” JIC FEMALE	6-0813
53	1	FLOW DIVIDER ASSEMBLY (INCLUDES 39 TO 51)	6-2315
54	1	DRIVER SIDE HYDRAULIC HOSE	2-1049
55	1	PASSENGER SIDE HYDRAULIC HOSE	2-2050
***NOTE		PUMP ASSEMBLY (INCLUDES 2 TO 20)	6-2110
		COMPLETE POWERPACK ASSEMBLY, 220V, 1 PHASE	0-0722
		COMPLETE POWERPACK ASSEMBLY, 220V, 3 PHASE	0-0759
		COMPLETE POWERPACK ASSEMBLY, 460V, 3 PHASE	0-0818
		COMPLETE POWERPACK ASSEMBLY, 575V, 3 PHASE	0-0760

12,000 LB WHEELTRON POWER PACK

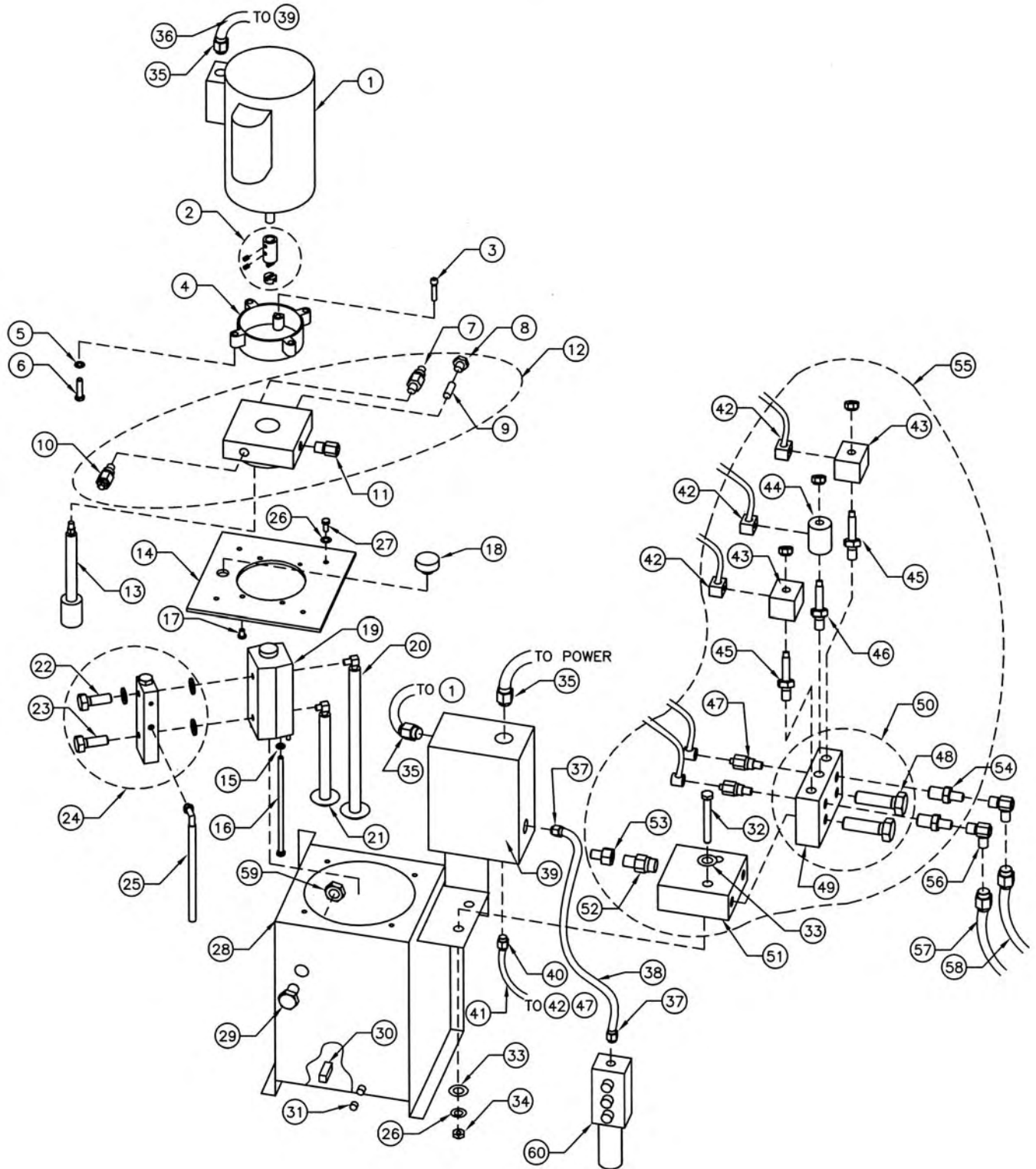

12,000 LB WHEELTRON POWER PACK - PARTS LIST

ITEM NO.	QTY.	DESCRIPTION	PART NO.
1A	1	MOTOR, 220V, 1 PHASE	6-0087
1B	1	MOTOR, 220V, 3 PHASE	6-0446
1C	1	MOTOR, 575V, 3 PHASE	6-0447
2	1	MOTOR COUPLER	6-2537
3	2	CAP SCREW, SOCKET HEAD, 5/16"-18UNC x 1 1/2" LG	6-2534
4	1	BELLHOUSING	6-2507
5	4	LOCKWASHER, INTERNAL TOOTH, 3/8"	6-2547
6	4	CAP SCREW, HEX HEAD, 3/8"-16UNC x 1 1/2" LG	6-2558
7	1	AUTO SWITCHING VALVE	6-2273
8	1	PLUG, 3/8" (INCLUDES "O"-RING)	6-2519
9	1	FLOW CONTROL , 1.5 – 2 GPM	6-2272
10	1	RELIEF VALVE (5400 PSI)	6-2265
11	1	SWIVEL ADAPTER (1/4" NPT MALE TO 3/8" JIC	6-2270
12	1	MAIN BODY ASSEMBLY (INCLUDES 7,8,9,10,11)	6-2557
13	1	RETURN FILTER ASSEMBLY	6-2546
14	1	MOUNTING PLATE	6-2521
15	4	LOCKWASHER, 5/16"	6-0674
16	2	CAP SCREW, HEX HEAD, 5/16"-18UNC x 6 1/2" LG	6-2533
17	4	CAP SCREW, BUTTIONHEAD, 5/16"-18UNC x 1/2" LG	6-2524
18	1	FILLER / BREATHER CAP	6-2523
19	1	TANDEM PUMP	6-2527
20	1	LONG INLET STRAINER ASSEMBLY	6-2528
21	1	SHORT INLET STRAINER ASSEMBLY	6-2529
22	1	BANJO BOLT (INCLUDES 2 WASHER SEALS)	6-2525
23	1	BANJO BOLT (INCLUDES 2 "O"-RINGS AND 1	6-2526
24	1	UNLOADING MANIFOLD ASSEMBLY(INCLUDING	6-2555
25	1	RETURN TUBE ASSEMBLY	6-2532
26	4	LOCKWASHER, 1/4"	6-0056
27	4	CAP SCREW, HEX HEAD, 1/4"-20UNC x 3/4" LG	6-0178
28	1	OIL RESERVOIR	4-0740
29	1	OIL LEVEL SIGHT PLUG	6-0517
30	1	MAGNET	6-0405
31	1	PLUG, SOCKETHEAD, 3/8" NPT	6-0102
32	2	CAP SCREW, HEX HEAD, 1/4"-20UNC x 2 3/4" LG	6-0648
33	4	FLAT WASHER, 1/4"	6-0060
34	4	NUT, HEX, 1/4"-20UNC	6-0032
35A	3	1/2" STRAIN RELIEF CONNECTOR (1 PHASE)	6-1370
35B	3	1/2" STRAIN RELIEF CONNECTOR (3 PHASE)	6-0094
36A	1	MOTOR CABLE (1 PHASE)	1-0104
36B	1	MOTOR CABLE (3 PHASE)	1-1824
37	1	3/8" STRAIN RELIEF CONNECTOR	6-0093
38	1	REMOTE CONTROL CABLE	6-1989
39A	1	CONTACTOR ASSEMBLY, 220V, 1PH INCLUDES:	
	1	PRINTED CIRCUIT BOARD	6-2125
	2	FUSE 2A 600V	6-2178
	1	CONTACTOR BOX, 1 PH, 24V COIL	6-2148
	1	TRANSFORMER, 220V	6-2126

39B	1	CONTACTOR ASSEMBLY, 220V, 3 PHASE INCLUDES:	
	1	PRINTED CIRCUIT BOARD	6-2125
	2	FUSE 2A 600V	6-2178
	1	CONTACTOR BOX, 3 PH, 24V COIL	6-2120
	1	TRANSFORMER, 220V	6-2126
	1	THERMAL OVERLOAD, 6 – 9.2A	6-2176
39C	1	CONTACTOR ASSEMBLY, 460V, 3 PHASE INCLUDES:	
	1	PRINTED CIRCUIT BOARD	6-2125
	2	FUSE 2A 600V	6-2178
	1	CONTACTOR BOX, 3 PH, 24V COIL	6-2120
	1	TRANSFORMER, 460V	6-2171
	1	THERMAL OVERLOAD, 2.7 – 4.2A	6-2175
39D	1	CONTACTOR ASSEMBLY, 575V, 3 PHASE INCLUDES:	
	1	PRINTED CIRCUIT BOARD	6-2125
	2	FUSE 2A 600V	6-2178
	1	CONTACTOR BOX, 3 PH, 24V COIL	6-2120
	1	TRANSFORMER, 575V	6-2147
	1	THERMAL OVERLOAD, 1.8 – 2.8A	6-2174
40	5	¼” STRAIN RELIEF CONNECTOR	6-0092
41	5	COIL / PRESSURE SWITCH CABLE	1-0105
42	3	DIN CONNECTOR (24V)	6-2236
43	2	SQUARE COIL (24V)	6-2128
44	1	ROUND COIL (24V)	6-2114
45	2	SPOOL VALVE (C/W MANUAL OVERRIDE)	6-2129
46	1	SPOOL VALVE (RESQUARE)	6-1364
47	2	PRESSURE SWITCH (INCLUDES BONDED SEAL)	6-2548
48	2	BANJO BOLT (INCLUDES BONDED SEAL)	6-2550
49	1	MANIFOLD	6-2551
50	1	MANIFOLD ASSEMBLY (INCLUDES 48-49)	6-2552
51	1	FLOW DIVIDER	6-2549
52	1	FILTER FITTING (BSP ½” MALE TO 3/8” JIC MALE)	6-2553
53	1	ADAPTER (3/8” JIC MALE TO 3/8” JIC FEMALE)	6-2559
54	2	FILTER FITTING (BSP 3/8” MALE TO 3/8” JIC MALE)	6-2127
55	1	FLOW DIVIDER ASSEMBLY (INCLUDES 42 TO 54)	6-2315
56	2	90° ELBOW (3/8” JIC MALE TO 3/8” JIC FEMALE)	6-0813
57	1	DRIVER SIDE HYDRAULIC HOSE	2-1049
58	1	PASSENGER SIDE HYDRAULIC HOSE	2-2050
59	5	½” CONDUIT LOCKNUT	6-1610
60	1	REMOTE HAND CONTROL, 2 BUTTON W/ LED	6-2038
***NOTE		PUMP ASSEMBLY (INCLUDES 2 TO 25)	6-2262
		COMPLETE POWERPACK ASSEMBLY 220V, 1 PHASE	0-0768
		COMPLETE POWERPACK ASSEMBLY 220V, 3 PHASE	0-0769
		COMPLETE POWERPACK ASSEMBLY 460V, 3 PHASE	0-0819
		COMPLETE POWERPACK ASSEMBLY 575V, 3 PHASE	0-0770

