

Snap-on®

2-POST

MODEL # EELR326A



INSTALLATION AND OPERATION MANUAL

**READ and SAVE THIS
INSTRUCTION MANUAL**

Snap-on®

Snap-On Tools Corporation

1-800-268-7959

MAR 2003 6-1640

TABLE OF CONTENTS

	PAGE
1 SAFETY AND OPERATING INSTRUCTIONS.....	2
2 SPECIFICATIONS	3
3 CONTENTS	4
4 INSTALLATION REQUIREMENTS	5
5 INSTALLATION INSTRUCTIONS	6
5.1 UNPACKING PROCEDURE	6
5.2 BAY LAYOUT.....	7
5.3 SAFETY SHUT-OFF BAR INSTALLATION	8
5.4 SAFETY SHUT-OFF BAR ADJUSTMENT	8
5.5 TOWER POSITIONING AND SETUP	10
5.6 ARM INSTALLATION	10
5.7 POWER PACK INSTALLATION.....	11
5.8 HYDRAULIC SYSTEM INSTALLATION	12
5.9 SAFETY RELEASE CABLE ROUTING AND ADJUSTMENT	14
5.10 HYDRAULIC SYSTEM BLEEDING AND LEVELING PROCEDURE.....	16
5.11 HYDRAULIC ADJUSTMENT PROCEDURE.....	17
5.12 TOWER POSITIONING AND ANCHORING.....	17
5.13 SHIMMING OF THE REMAINING TOWER	19
5.14 ARM RESTRAINT ADJUSTMENT.....	20
6 LIFT MAINTENANCE GUIDELINES.....	20
6.1 SAFETY INSTRUCTIONS.....	20
6.2 PERIODIC MAINTENANCE.....	20
7 SAFETY AWARENESS - AUTOMOTIVE LIFT INSTITUTE (ALI)	22
8 PARTS MANUAL	23
8.1 LIFT ASSEMBLY.....	23
8.2 LIFT ASSEMBLY PARTS LIST	24
8.3 HYDRAULIC SYSTEM	26
8.4 HYDRAULIC SYSTEM PARTS LIST.....	27
8.5 HYDRAULIC SYSTEM PARTS LIST.....	28
8.6 POWER PACK: #6-2055 (AB-1381) 208-230V/1PH/60Hz.....	28
8.7 POWER PACK PARTS LIST: #6-2055 (AB-1381) 208-230V/1PH/60Hz.....	29

1 SAFETY AND OPERATING INSTRUCTIONS

1. When using this lift, basic safety precautions should always be followed, including the following.
2. Read all instructions in this manual and on the lift.
3. Inspect lift daily. Do not operate if it malfunctions or problems have been encountered.
4. Never attempt to overload the lift. The manufacturer's rated capacity is shown on the identification label on the power side column. Do not override the operating controls or the warranty will be void.
5. Before driving vehicle between the towers, position the arms to the drive-through position to ensure unobstructed clearance. Do not hit or run over arms as this could damage the lift and/or vehicle.
6. Only trained and authorized personnel should operate the lift. Do not allow customers or bystanders to operate the lift or be in the lift area.
7. Position the lift support pads to contact the vehicle manufacturers recommended lifting points. Raise the lift until the pads contact the vehicle. Check pads for secure contact with the vehicle. Check all arm restraints and insure they are properly engaged. Raise the lift to the desired working height.
8. Some pickup trucks may require an optional truck adapter to clear running boards or other accessories.
NOTE: Always use all 4 arms to raise and support vehicle.
9. **Caution! Never work under the lift unless the mechanical safety locks are engaged.**
10. Note that the removal or installation of some vehicle parts may cause a critical load shift in the center of gravity and may cause the vehicle to become unstable. Refer to the vehicle manufacturer's service manual for recommended procedures.
11. Always keep the lift area free of obstruction and debris. Grease and oil spills should always be cleaned up immediately.
12. Never raise vehicle with passengers inside.
13. Before lowering check area for any obstructions.
14. Before removing the vehicle from the lift area, position the arms to the drive-through position to prevent damage to the lift and /or vehicle.

2 SPECIFICATIONS

Capacity:
 Overall Width:
 Width Between Columns:
 Drive-Thru Width:
 Overall Height:
 Under Bar Clearance:
 Height to Lowered Lift Pads:
 Height to Raised Low Lift Pad:
 Height to Raised High Lift Pad:
 Front Arm Retracted Length:
 Front Arm Extended Length:
 Rear Arm Retracted Length:
 Rear Arm Extended Length:
 Maximum Lifting Height:
 Lift Time:
 Power Requirements (Standard):

9000 lbs.	4090 kg
134"	3404mm
107"	2717mm
86 1/2"	2197mm
144"	3658mm
140"	3556mm
4"	102mm
5 3/4"	146mm
8 3/4"	222mm
23 1/4"	591mm
36 3/4"	933mm
35 3/4"	908mm
57 1/4"	1454mm
77 1/4"	1962mm
45 seconds	
230 Volts AC, 1 Ph., 60Hz.	

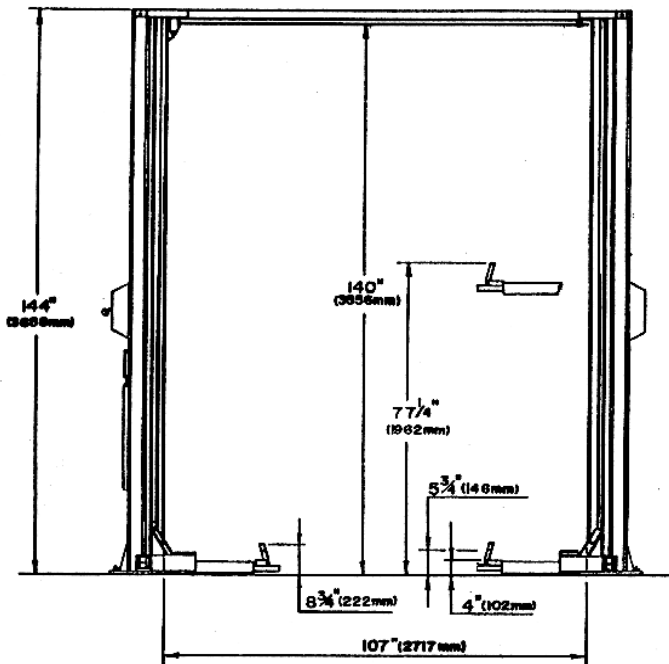

Figure 1 – Front View

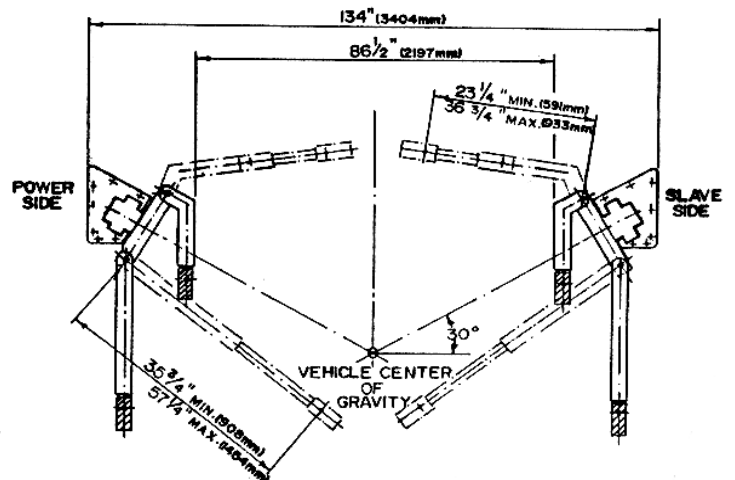

Figure 2 – Top View

3 CONTENTS

The complete lift is contained in two (2) packages:

1. The **main structural components** are packed in a steel frame.
2. The remaining parts are packed in an **accessory box**.

Main Structural Components includes:

- 1pc. - Power side tower and carriage assembly
- 1pc. - Slave side tower and carriage assembly
- 1pc. - Crossmember
- 1pc. - Hydraulic line for crossmember

Accessory box contents:

- 2pcs. - Front arms (Short) w/arm pins
- 2pcs. - Rear arms (Long) w/arm pins
- 2pcs. - Safety Covers w/Decals
- 1pc. - Power Pack
- 1pc. - Safety release cable assembly
- 1pc. - Valve Block (C/W Fittings)
- 1pc. - Safety shut-off microswitch assembly
- 1pc. - Hardware package w/Packing List
- 1pc. - Owner's manual
- 1pc. - ALI manual "Lifting It Right"
- 1pc. - Automotive Lift Safety Tips
- 1pc. - Automotive Lift, Operation, Inspection and Maintenance manual
- 1pc. - "ALI" Quick Reference Guide

4 INSTALLATION REQUIREMENTS

IMPORTANT: It is the user's responsibility to provide a satisfactory installation area for the lift. Lifts should only be installed on level concrete floors with a minimum thickness of five (5) inches or 130 mm. Concrete must have a minimum strength of 4000 psi or 30 MPa and should be aged thirty (30) days prior to installation. Please consult the architect, contractor or engineer if doubt exists as to the strength and feasibility of the floor to enable proper lift installation and operation.

It is the user's responsibility to provide all wiring for electrical hook-up prior to installation and to insure that the electrical installation conforms to local building codes. Where required, it is the user's responsibility to provide an electrical isolation switch located in close proximity to the lift that will enable emergency stop capability and isolate electrical power from the lift for any servicing requirements.

Tools Required:

- a. 16ft. Measuring Tape
- b. Chalk Line
- c. Rotary Hammer Drill
- d. 3/4" diameter Masonry Drill Bit
- e. Hammer
- f. SAE Wrenches and Ratchet Set
- g. 2ft. Level
- h. 4ft. Level
- I. Crow Bar
- j. One 12ft. Step Ladder
- k. Side Cutters
- l. Screwdrivers
- m. 15 ft. Bleeder Hose (Clear) w/ 3/8" JIC Swivel F fitting on one end
- n. 4" x 4" Wooden Blocks (for unpackaging)

5 INSTALLATION INSTRUCTIONS

When the lift arrives on site, please read the owner's manual and check for any freight damages. Also, check the contents to make sure no parts are missing before starting installation. Gather all the tools listed and make sure the installation instructions are fully understood before commencing installation.

5.1 UNPACKING PROCEDURE

1. **Important!** Place the main structural components on wooden blocks so that the steel frames can be removed.
2. Remove plastic wrapping.
3. Remove crossmember, hydraulic line, and extensions.
4. Remove steel frames.
5. Lay towers on floor with the carriage side up.
6. Check the installation area for obstructions. (Lights, Heating Ducts, Ceiling, Floor Drains...etc.)
7. Prepare the bay by selecting the location of the lift relative to the walls. Clear area of all packaging materials to avoid trip hazards. Draw a chalk line on the floor to represent the center line of the bay and a second chalk line crossing at 90° for locating the lift towers. Refer to **Figure 3**.

5.2 BAY LAYOUT

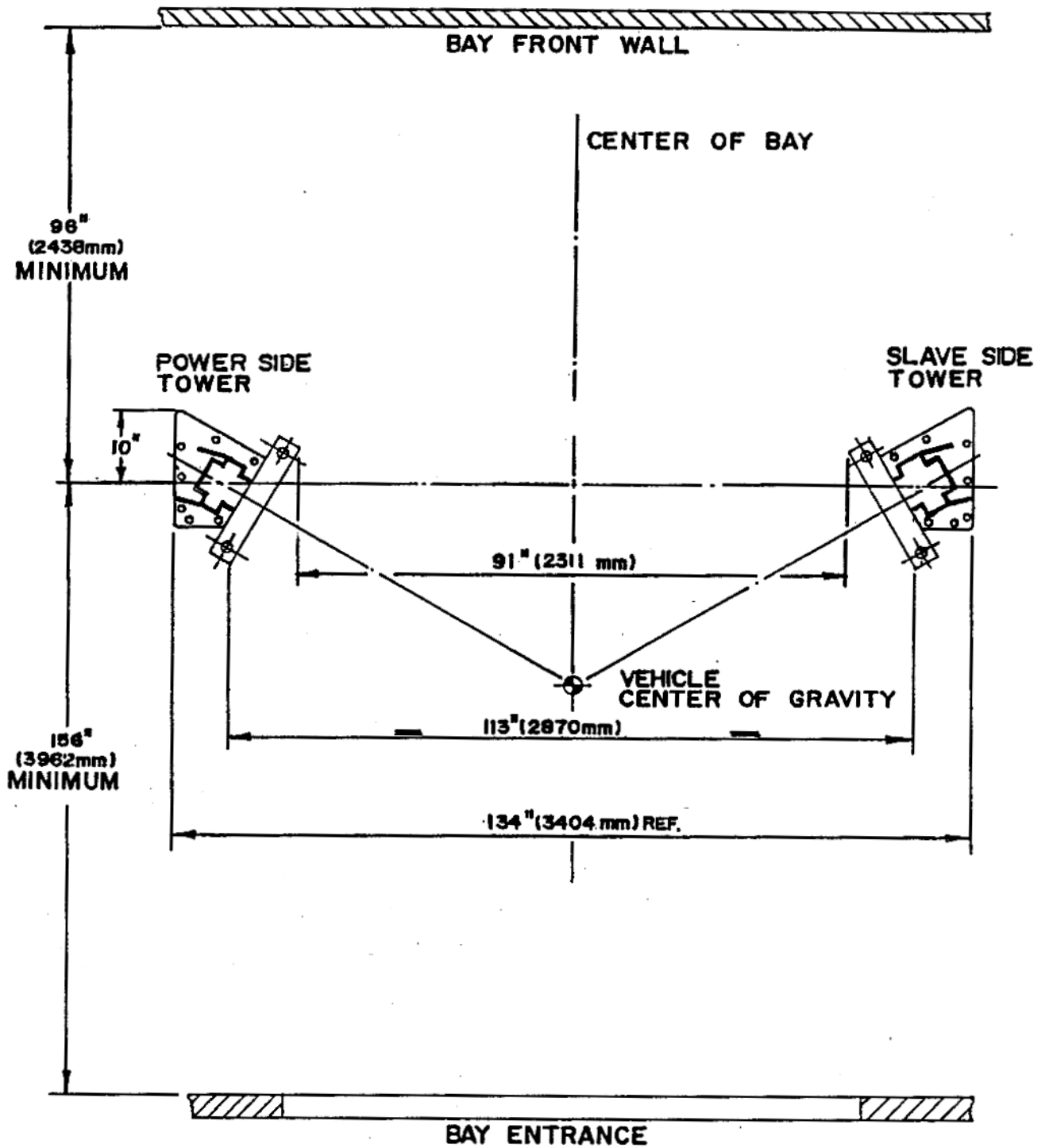

Figure 3 – Bay Layout

5.3 SAFETY SHUT-OFF BAR INSTALLATION

Note: The safety shut off will disconnect the power to the power pack when an obstruction touches the padded bar or the carriages reach their maximum extension. The safety shut off switch is factory pre-wired. Refer to Figure 4 and 5.

Note: This procedure can be done on the floor.

1. Attach the Actuator Mounting Bracket (1-1378) to the crossmember using hex head bolt 1/4" NC x 3/4" lg. bolt (6-0178), lockwasher 1/4" dia. (6-0056), and hex nut 1/4" NC (6-0032).
2. Attach Actuator Bar assembly to the Actuator Mounting Bracket assembly using hex head bolt 1/4" NC x 1 1/2" lg. (6-0027), lockwasher (6-0178), and hex nut 1/4" NC (6-0032).
3. Slide Safety Shut-Off Microswitch Assembly over open end of actuator bar and bolt the assembly to the crossmember using hex head bolt 1/4" NC x 3/4" lg. (6-0178), lockwasher (6-0178), and hex nut 1/4" NC (6-0032).
4. Bolt Actuator Extension (1-1379) onto open end of actuator bar using (2x) hex head bolt 1/4" NC x 1 1/4" lg. (6-0027), lockwasher (6-0178), and hex nut 1/4" NC (6-0032).

5.4 SAFETY SHUT-OFF BAR ADJUSTMENT

Note: This procedure must be done last.

1. When the lift is fully installed, leveled, and operational, extend the carriages to their full upper limit.
2. Lower the carriages about 1/4" to 1/2".
3. Adjust the stopper bolt by threading the upper nut towards the head, and the lower nut towards the bottom.
4. The bottom of the bolt should be touching the top of the carriage.
5. Tighten both stopper nuts onto the actuator bar extension.

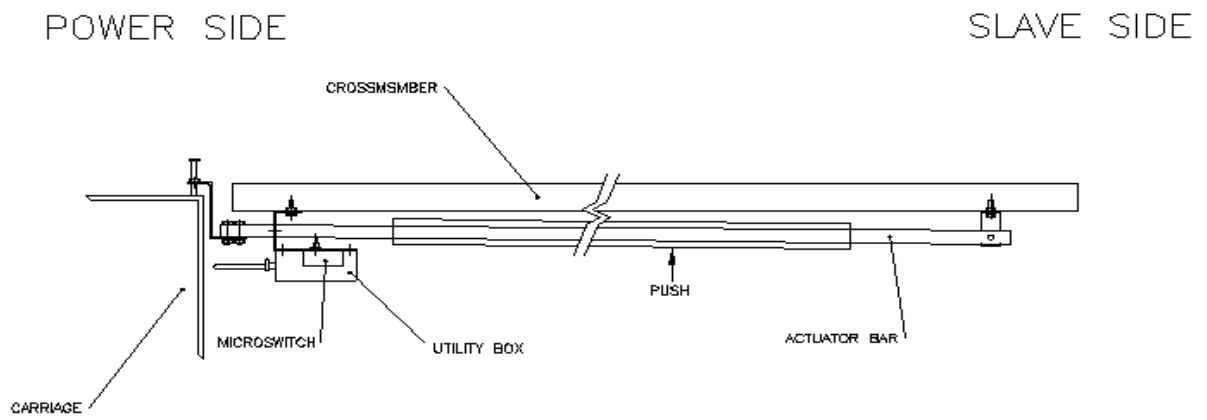

Figure 4 – Safety Shut-Off Bar Installation

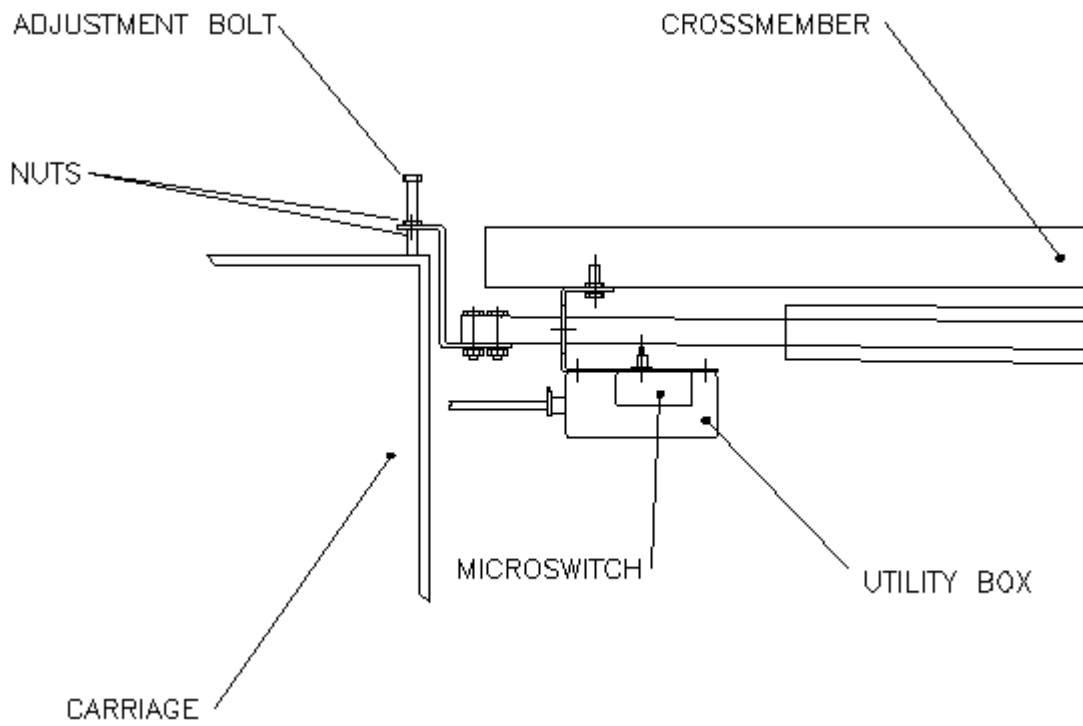

Figure 5 – Safety Shut-Off Bar (Power Side)

5.5 TOWER POSITIONING AND SETUP

1. Locate the power side and slave side tower to the relative position as shown on **Figure 3**. Double check all dimensions.
2. Using a step ladder, install the crossmember. Raise and place the crossmember mounting hooks over the top of the tower. Install and **tighten** the crossmember using four (4) 1/2"-13UNC x 1 1/2"LG. hex head bolts, flat washers, lock washers and hex nuts.
3. Check the towers to make sure they are located, and positioned in the correct location. Refer to **Figure 3**.

5.6 ARM INSTALLATION

1. Remove (4) 5/16"-18UNC x 3/4"LG. hex head bolts that are locking the arm pins to the arm. Install arms to carriages. Install so that the shorter arms (with the 30° bend) are on the front, and the long arms on the rear. Refer to **Figure 6**.
2. Grease and insert arm pins. Align notch on arm pins to the tapped hole on the arm. Using the 5/16" hex head bolts removed in previous step, reinstall and tighten securely.

NOTE: Arm restraint device to be installed in Section 5.14.

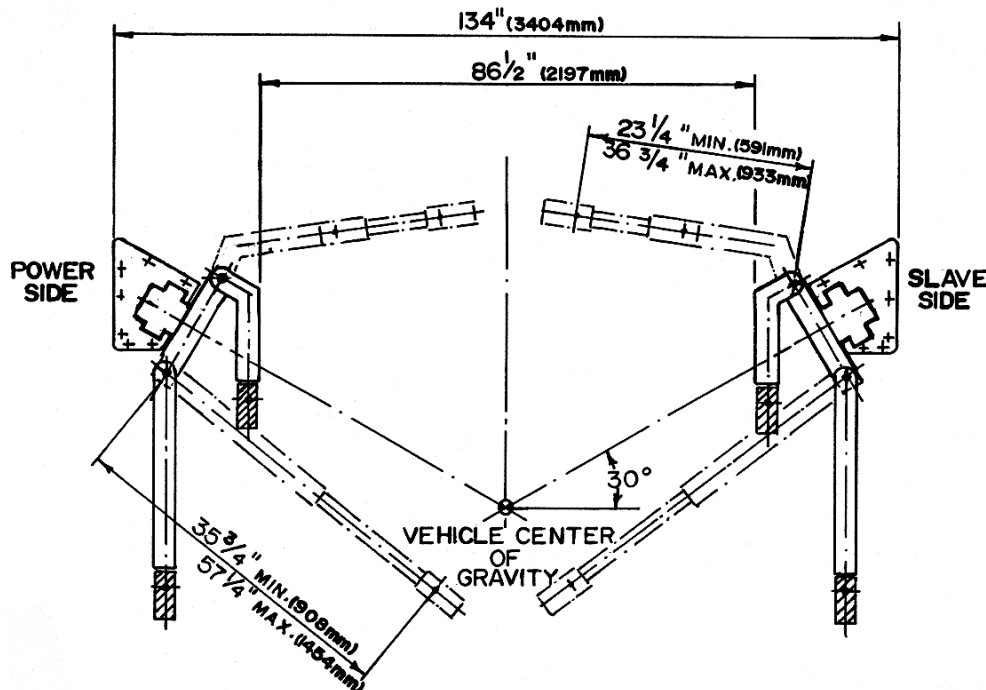

Figure 6 – Arm Installation

5.7 POWER PACK INSTALLATION

1. Remove the **red** plastic cap located at the rear of the power pack, and install the 90° fitting (page 25, item 18) located in the hardware kit.
2. Bolt power pack to the mounting bracket on the power side tower using four (4) 5/16"-18UNC x 1"LG. hex head bolts, lock washers, flat washers and nuts. Do not tighten.
3. A **certified electrician** must connect the 230Volt/Single phase power to the motor. The electrical diagram is provided, refer to **Figure 8**.

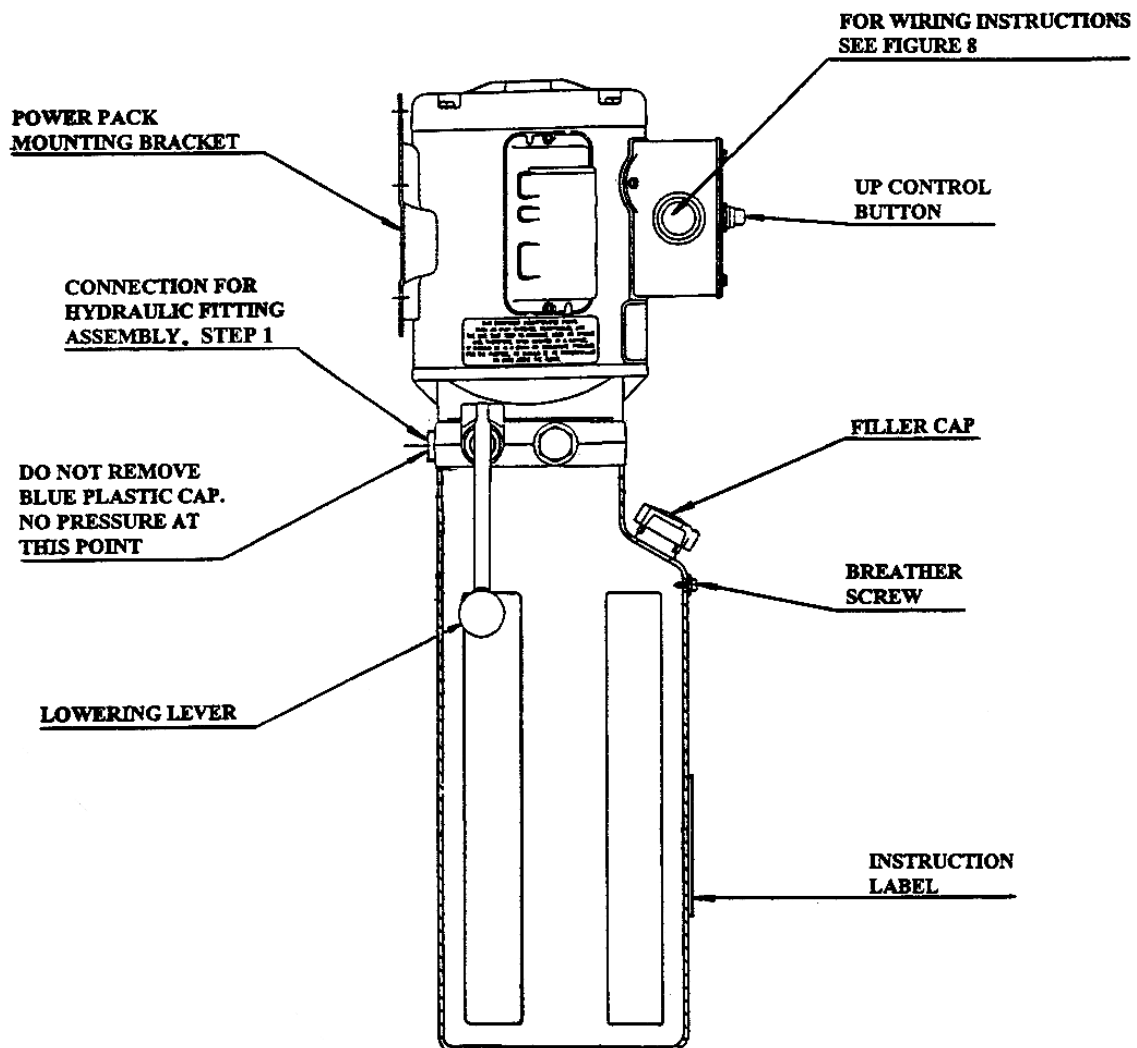

Figure 7 – Powerpack Details

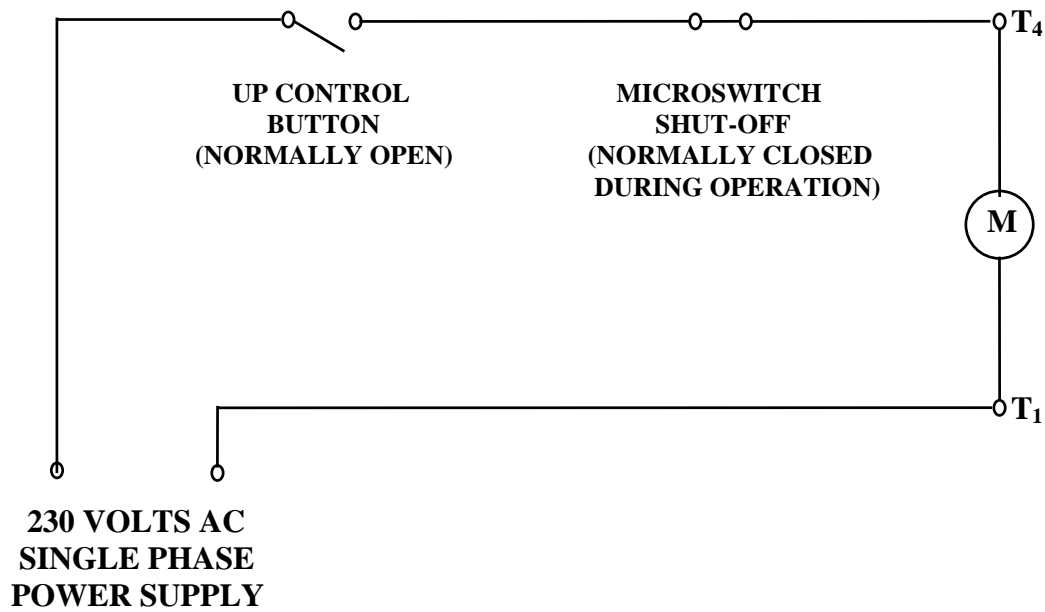

Figure 8 – Electrical Diagram

5.8 HYDRAULIC SYSTEM INSTALLATION

Refer to **Figure 9** and **10**, and the Hydraulic System Parts List on page 26

Note: Save hydraulic caps and plugs for future use.

1. Do not tighten any hydraulic fittings until all connections have been made.
2. Remove plug from item 17. Install item 17 (page 26) to the 90° fitting on the power pack (item 18).
3. Install the valve block to the power side tower using items 23 & 5.
4. On the power side cylinder, remove the cap off item 28 at the bottom rear and install item 27.
5. Attach item 27 to item 53 on valve block.
6. At the bottom of the power side cylinder, remove the 1/4" cap from item 25 and attach it to item 51 on valve block.
7. Attach the other end of item 17 to the 90° fitting (item 18) on the valve block.
8. Remove the two caps on item 39 and place it in the crossmember. Connect the slave side end of this line to a bulkhead fitting (item 1) attached to the hydraulic line (item 6).

9. Connect the power side end to the bulkhead fitting (item 1) attached to the hydraulic line (item 30).
10. TIGHTEN ALL HYDRAULIC CONNECTIONS.
Caution: Over tightening could cause the flare seal to break.
11. Remove filler cap from power pack, and fill reservoir with 3.5 Gal. (13.2 L) of ISO32 hydraulic oil (10 weight hydraulic oil). Remove breather screw when filling and replace when full. Refer to **Figure 7**.

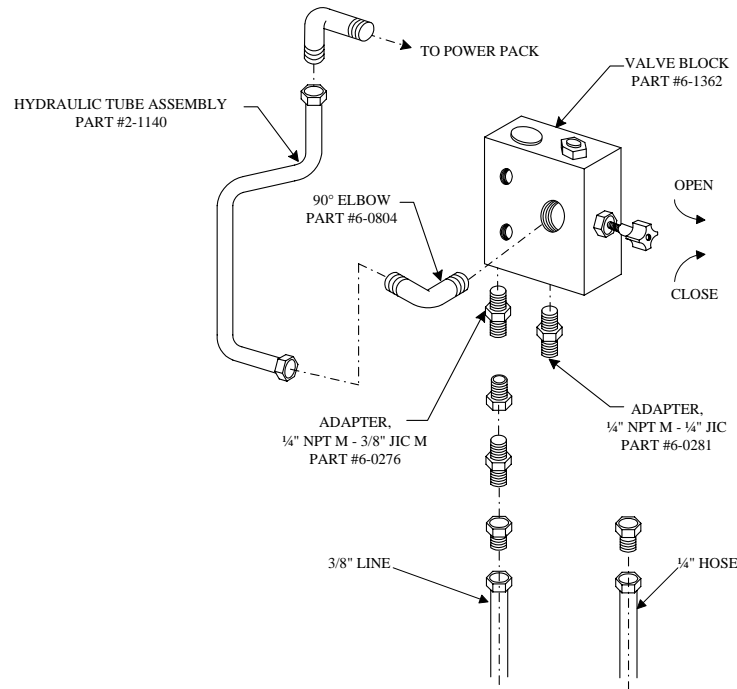

Figure 9 – Hydraulic System Connections

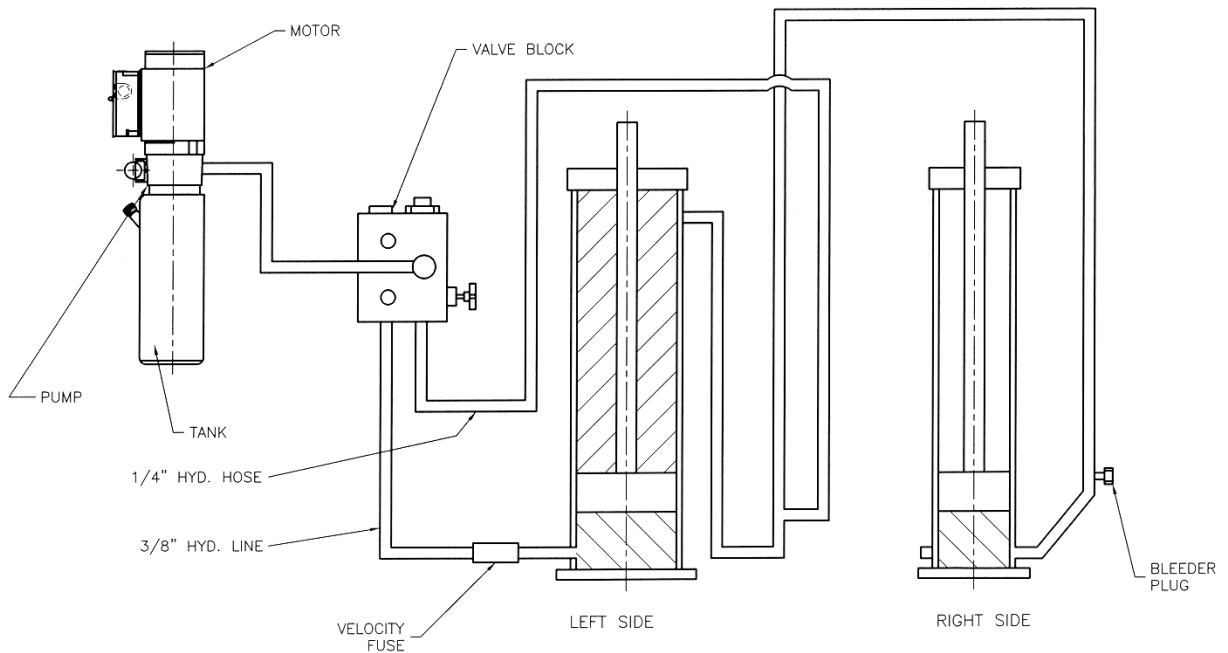

Figure 10 – Hydraulic System Schematic

5.9 SAFETY RELEASE CABLE ROUTING AND ADJUSTMENT

The mechanical safety automatically engages. To release the mechanical safety, you must first raise the lift approximately 2", then pull the safety release lever down. This disengages the power side safety dog and activates the safety cable to release the slave side safety dog.

1. Install the safety release bracket on each tower as shown in Figure 10. Attach the safety pulley to the bracket using the 3/8" x 5/8" LG. shoulder bolt, 5/16" lockwasher and 5/16" hex nut. Attach the pulley bracket, complete with pulley, to the tower using the 5/16" x 3/4" LG. hex bolt, 5/16" flat washer, 5/16" lockwasher, and 5/16" hex nut.

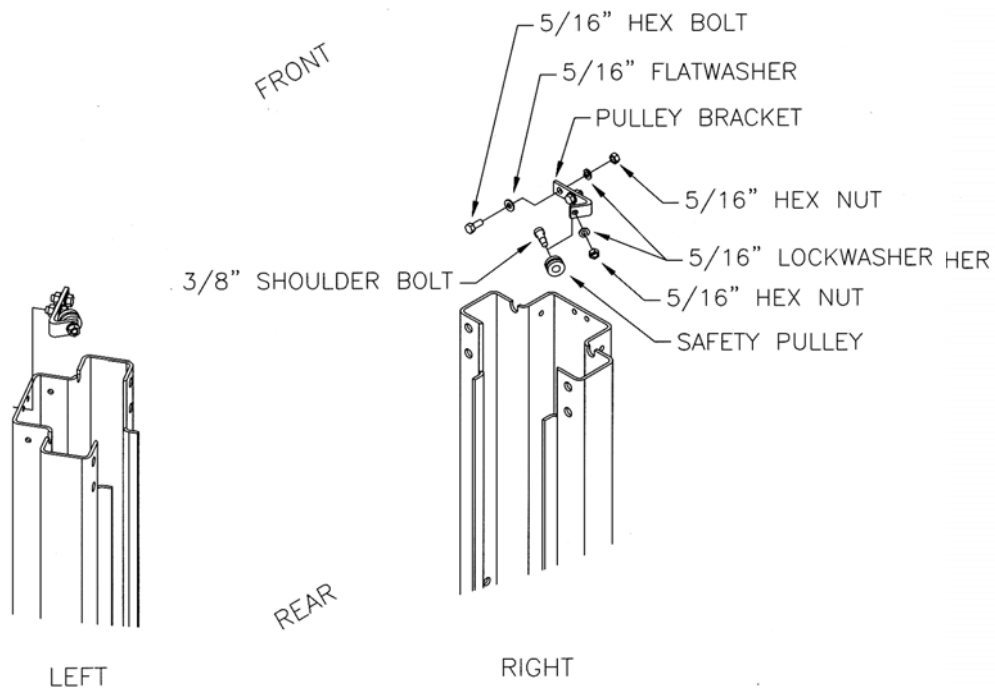

Figure 11 - Safety Release Pulley Installation

2. Refer to **Figure 12** for safety release cable routing. The end of the cable that has a collar attaches to the slave side safety dog. The free end is fixed to the power side safety dog using two (2) wire rope clips.
3. Install the safety release handle onto the power side safety dog.
4. Start routing the safety release cable from the slave side of crossmember. Feed the cable over the small pulley, then guide the cable down along the inside of the slave side tower. Pull the cable out through the opening in the back of the tower near the safety dog.

5. Guide the cable up under the large pulley towards the end of the safety dog. Remove the 3/8" x 1 1/2" shoulder bolt from the safety dog. Feed the shoulder bolt through the collar of the safety release cable and then replace the shoulder bolt securely to the safety dog. **NOTE:** Make sure shoulder bolt, 3/8" dia. x 1 1/2" lg. (6-0801), is lock tight to safety dog.
6. Repeat step 2 for the power side tower.
7. Guide the cable up under the large pulley and then over the small pulley towards the safety dog. Wrap the cable around the thimble (attached to the safety dog with a 3/8" x 1 1/2" lg. shoulder bolt) and then clamp it using two (2) wire rope clips. Do not tighten fully at this stage.
8. Adjust the cable length so that both safety dogs travel from full engagement position to full release position when the safety release handle is pulled. **Tighten both wire rope clips firmly when adjustment is completed.**

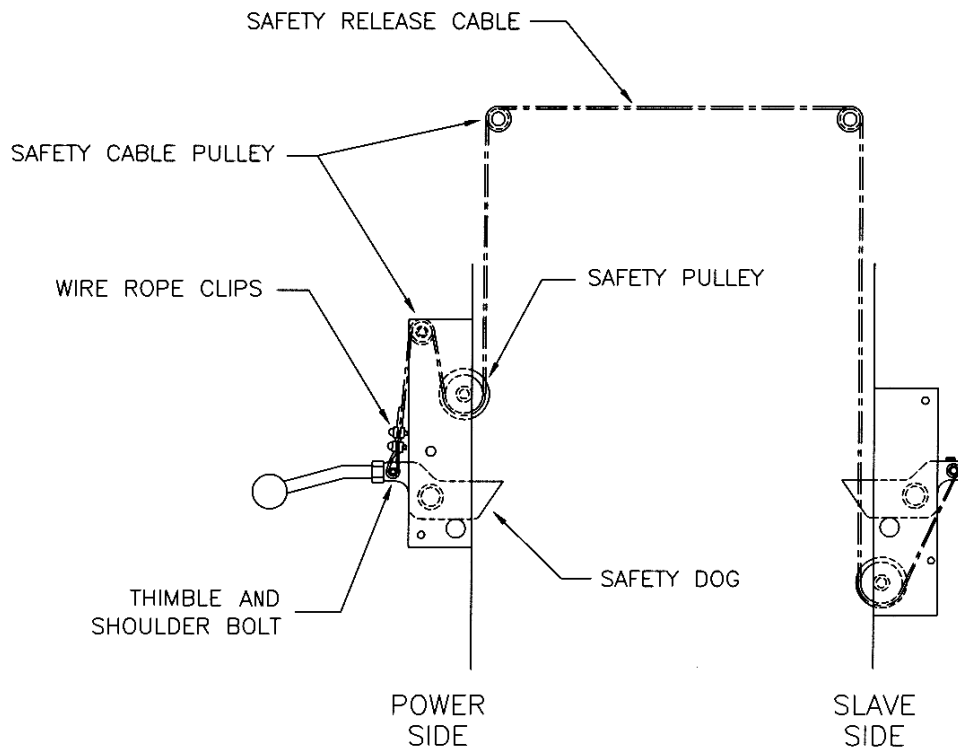

Figure 12 – Safety Release Cable Routing and Adjustment

5.10 HYDRAULIC SYSTEM BLEEDING AND LEVELING PROCEDURE

1. Ensure that both carriages are fully lowered.
2. Remove the bleeder cap from the “T” fitting at the bottom of the slave side cylinder.
3. Attach a 15ft. clear bleeding hose to the same fitting, and place the open end of the hose into the power pack’s reservoir’s filler neck or in a container in which the oil came in for reuse. Hose should be secured during the bleeding procedure.
4. Close the by-pass valve, and power up until the power side carriage reaches the carriage stops.
5. Open the by-pass valve, and power up until oil is seen flowing out of the bleeder hose. (No Air Bubbles). Bleed at least 1 gal. of hydraulic fluid through the system.
6. Remove the bleeding hose and reinstall the bleeder cap. Replace breather/filler cap.
7. Power up until slave side carriage reaches the carriage stops.
8. Close the by-pass valve and lower lift (both sides) until both carriages are fully collapsed. Power up and lower (14”) lift a few times. When lift is fully down, open the by-pass valve and raise the slave side 2-3” higher than the power side. Close the by-pass valve.
9. Power up, and lower lift onto the first safety, on the power side. Open the by-pass valve and lower slave side onto the same first safety. Close the by-pass valve. Lift is now synchronized hydraulically.
10. Both power and slave sides must be completely down.
11. Check and add hydraulic fluid to power pack before cycling lift.
12. Install safety covers, and safety release lever knob. Securely.
13. After anchoring, set up a vehicle on the lift to make sure hydraulics are operating properly.

5.11 HYDRAULIC ADJUSTMENT PROCEDURE

Important! Should your lift come out of synchronization, i.e. one carriage is higher than the other, it is necessary to level the lift hydraulically.

When **slave** side is **higher** than the power side:

1. Lower lift on to the first safety on the power side.
2. Open by-pass valve. Push the down control lever. This will cause the slave side carriage to be lowered. Stop lowering when the slave side carriage stops on the first safety.

When **power** side is **higher** than the slave side:

1. Open the by-pass valve, raise lift until the slave side carriage is approximately 1-2” higher than the power side carriage. Stop raising and close by-pass valve.
2. Lower lift by pushing the down control lever. Stop lowering when the power side carriage touches the first safety.
3. Next, open the by-pass valve. Push the down control lever so that the slave side carriage lowers. Stop lowering when the slave side carriage touches the first safety. Close the by-pass valve.

5.12 TOWER POSITIONING AND ANCHORING

WARNING! Failure to follow these instructions may cause an unsafe operating condition.

WARNING! Before proceeding with installation, review Section 4: Installation Requirements & Tools.

1. Using a 4ft. level on top of the crossmember, determine which column is higher (**Figure 13**).
2. Using 2 ft. level on the sides of the high column, ensure that the column is level in the vertical position (**Figure 14**). Use shims under the column baseplate to hold the column level. Ensure that the base plate is completely supported by shims where it does not contact the floor (**Figure 15**).

WARNING! Do not use more than 1/2” (13mm) of shims. Anchor bolts supplied allow for a maximum of 1/2” (13mm) of shim. If more than 1/2” (13mm) of shims are required, **DO NOT** proceed with installation and contact Product Manufacturer / Supplier for further details.

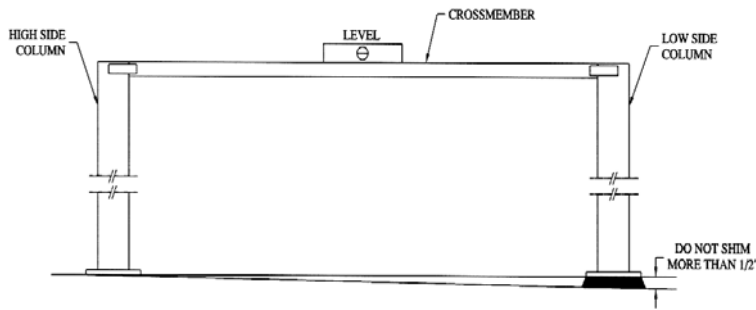

Figure 13 – Crossmember Leveling

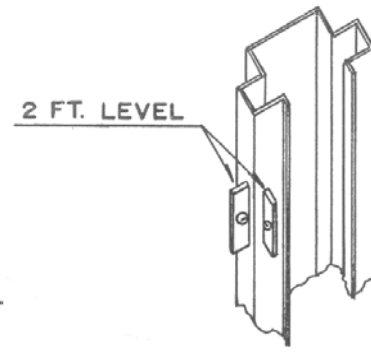

Figure 14 – Tower Leveling

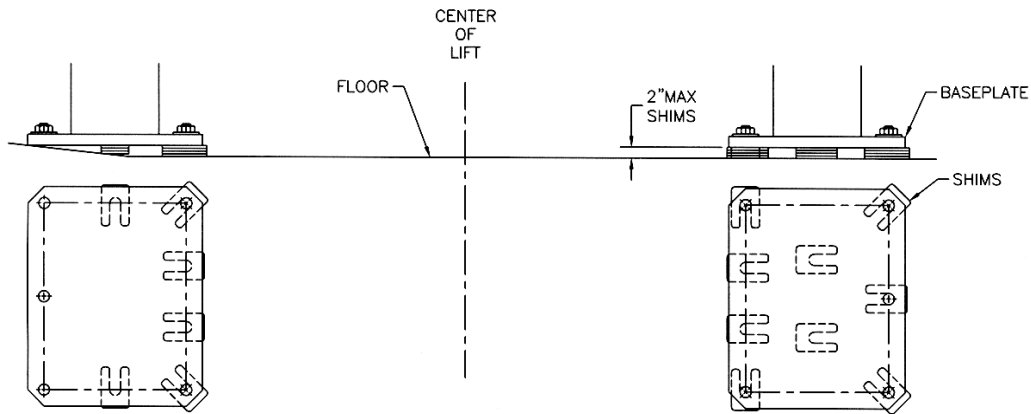

Figure 15 – Shim Placement

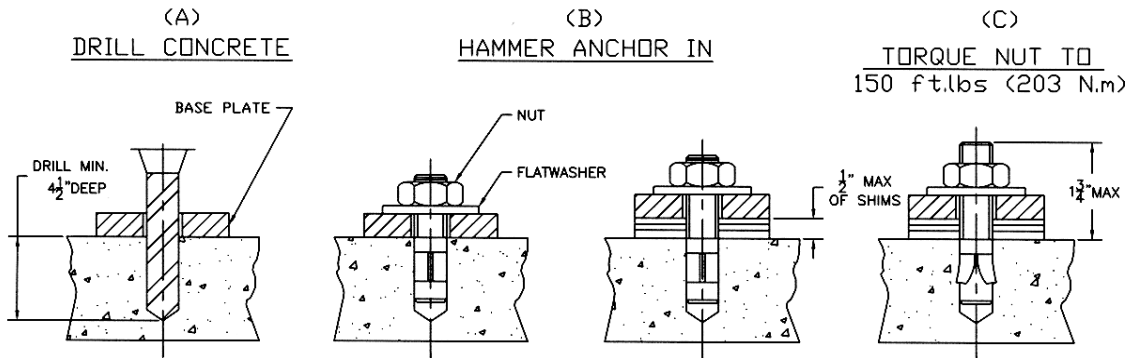

Figure 16 – Anchor Installation

3. Refer to Bay Layout (**Figure 3**) to ensure that the column is still in the proper position. Using a rotary hammer drill with a 3/4" masonry drill bit, drill holes in the floor on the high side column using the tower baseplate as a template. Make sure that the 3/4" masonry drill is in good condition (**Figure 16A**).
4. Carefully clean out drilling dust from the anchor holes. Hammer in the anchor bolts (**Figure 16B**). Hand tighten all anchor bolts.

5. Reconfirm that the column is level front to rear and side to side (**Figure 14**). Add or remove shims as required.
6. Torque all anchor bolts to 150 ft-lbs. (203 Nm), continually checking that the column is level as you proceed. If anchor bolts do not tighten to 150 ft-lbs. OR project more than 1 3/4" above the concrete surface (**Figure 16C**), the concrete MUST be replaced by an appropriate concrete pad. (Consult Product Manufacturer / Supplier for further details).

5.13 SHIMMING OF THE REMAINING TOWER

1. Using a 4ft. level on the crossmember (**Figure 14**) and a 2ft. level on the low side column (**Figure 14**), shim underneath the baseplate until the crossmember and column are level. Ensure that the baseplate is completely supported by shims where it does not contact the floor (**Figure 15**).

WARNING! Do not use more than 1/2" (13mm) of shims. Anchor bolts supplied allow for a maximum of 1/2" (13mm) of shim. If more than 1/2" (13mm) of shims are required, DO NOT proceed with installation. Contact Product Manufacturer / Supplier for further details.

2. Refer to Bay Layout (**Figure 3**) to ensure that the column is still in the proper position. Using a rotary hammer drill with a 3/4" masonry drill bit, drill holes in the floor on the low side column using the column baseplate as a template. Make sure that the 3/4" masonry drill is in good condition (**Figure 16A**).
3. Carefully clean out drilling dust from the anchor holes. Hammer in the anchor bolts (**Figure 16B**). Hand tighten all anchor bolts.
4. Reconfirm that the crossmember is level (**Figure 13**) and that the column is level front to rear and side to side (**Figure 14**). Add or remove shims as required.
5. Torque all anchor bolts to 150 ft-lbs. (203 Nm), continually checking that the crossmember and column are level as you proceed. If anchor bolts do not tighten to 150 ft-lbs. OR project more than 1 3/4" above the concrete surface (**Figure 16C**), the concrete MUST be replaced by an appropriate concrete pad. (Consult Product Manufacturer / Supplier for further details).
6. Verify that the entire lift is level both horizontally and vertically, to ensure optimum lifting performance.

***Perform a monthly inspection and torque all anchor bolts to 150 ft-lbs. (203 Nm).**

5.14 ARM RESTRAINT ADJUSTMENT

The arm restraint are designed to automatically engage when the lift is raised and disengage when the lift is fully lowered. The arm restraint can be adjusted by turning the arm restraint bolt (**Figure 17**).

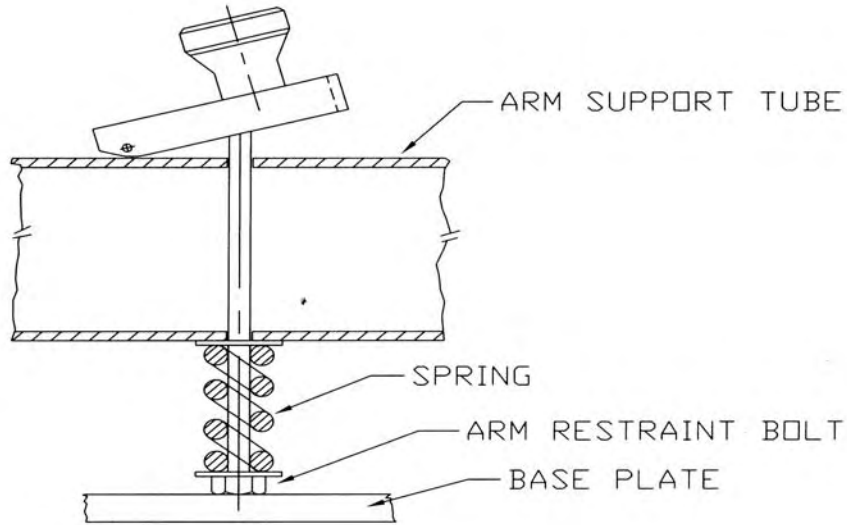

Figure 17 – Arm Restraint Adjustment

6 LIFT MAINTENANCE GUIDELINES

6.1 SAFETY INSTRUCTIONS

Read operating and safety manuals before using any lift
Do not operate a lift that has been damaged or is in disrepair
Proper inspection and maintenance is necessary for safe operation

6.2 PERIODIC MAINTENANCE

DAILY:

1. Check all hydraulic lines and fittings for pinch points, damage , cracks or leaks
2. Check all electrical wiring for pinch points, cracks or damage
3. Check all moving parts for uneven or excessive wear
4. Repair or replace all damaged, defective, worn or broken components immediately
5. Check the telescopic arms for movement. Clean any grease or oil from the lifting adapters

6. Raise and lower the lift at the beginning of each shift, without a vehicle on, to verify the lift is leveled and operating properly. Perform hydraulic leveling procedure when the lift is out of level.

WEEKLY:

1. Check and adjust hydraulic level

EVERY TWO MONTHS:

1. Clean and re-grease slide block channels inside of both columns
2. Grease arm pins
3. Check and lubricate safety dogs and safety cable adjustment
4. Check arm restraints and lubricate
5. Dismantle and clean inner arms
6. Check anchor bolts and re-torque if required
7. Check bolts on the carriage stops for tightness. Note: The carriage stop on the slave side tower should have the thicker side facing downwards, and on the power side facing upwards. Refer to **Figure 18**.

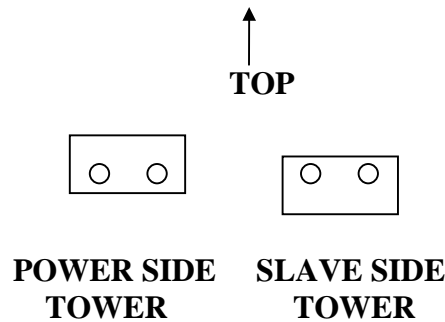

Figure 18 – Carriage Stops

EVERY YEAR:

1. Inspect lift as per Automotive Lift Operation, Inspection and Maintenance (ALOIM)

EVERY TWO YEARS:

1. Change hydraulic fluid









LUBRICATION:

- | | | |
|-----------------------------------|---|--|
| Where grease is required | > | multi-purpose lithium grease |
| Where lubricating oil is required | > | multi-purpose SAE 30 lubricating oil |
| Where hydraulic oil is required | > | ISO 32 10W - non detergent hydraulic oil |

NOTE: If lift locks while in the fully raised position this will indicate that the

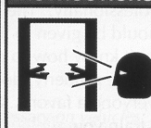
hydraulic system has not been inspected or maintained as recommended. This is a safety back-up system. If you are unclear call your local representative immediately.

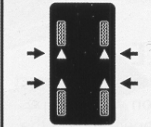
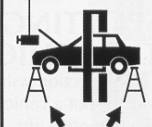
7 SAFETY AWARENESS - AUTOMOTIVE LIFT INSTITUTE (ALI)

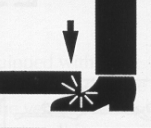
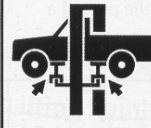
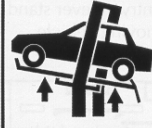
<p>▲ WARNING</p>  <p>Clear area if vehicle is in danger of falling.</p>	<p>▲ WARNING</p>  <p>Position vehicle with center of gravity midway between adapters.</p>	<p>▲ CAUTION</p>  <p>Lift to be used by trained operator only.</p>	<p>▲ CAUTION</p>  <p>Authorized personnel only in lift area.</p>	<p>SAFETY INSTRUCTIONS</p>  <p>Read operating and safety manuals before using lift.</p>	<p>SAFETY INSTRUCTIONS</p>  <p>Proper maintenance and inspection is necessary for safe operation.</p>
<p>▲ WARNING</p>  <p>Remain clear of lift when raising or lowering vehicle.</p>	<p>▲ WARNING</p>  <p>Avoid excessive rocking of vehicle while on lift.</p>	<p>▲ CAUTION</p>  <p>Use vehicle manufacturer's lift points.</p>	<p>▲ CAUTION</p>  <p>Always use safety stands when removing or installing heavy components.</p>	<p>SAFETY INSTRUCTIONS</p>  <p>Do not operate a damaged lift.</p> <p>The messages and pictographs shown are generic in nature and are meant to generally represent hazards common to all automotive lifts regardless of specific style.</p> <p>Funding for the development and validation of these labels was provided by the Automotive Lift Institute, P.O. Box 33116, Indianapolis, IN 46232-3116. They are protected by copyright. Set of labels may be obtained from ALI or its member companies.</p> <p>© 1992 by ALI, Inc. ALI/WS1014</p>	
<p>▲ WARNING</p>  <p>Do not override self-closing lift controls.</p>	<p>▲ WARNING</p>  <p>Keep feet clear of lift while lowering.</p>	<p>▲ CAUTION</p>  <p>Use height extenders when necessary to ensure good contact.</p>	<p>▲ CAUTION</p>  <p>Auxiliary adapters may reduce load capacity.</p>	<p>Warning Labels for 2-post surface mounted lifts. Daily review of these Safety Messages and Warnings is suggested.</p>	

8 PARTS MANUAL

8.1 LIFT ASSEMBLY

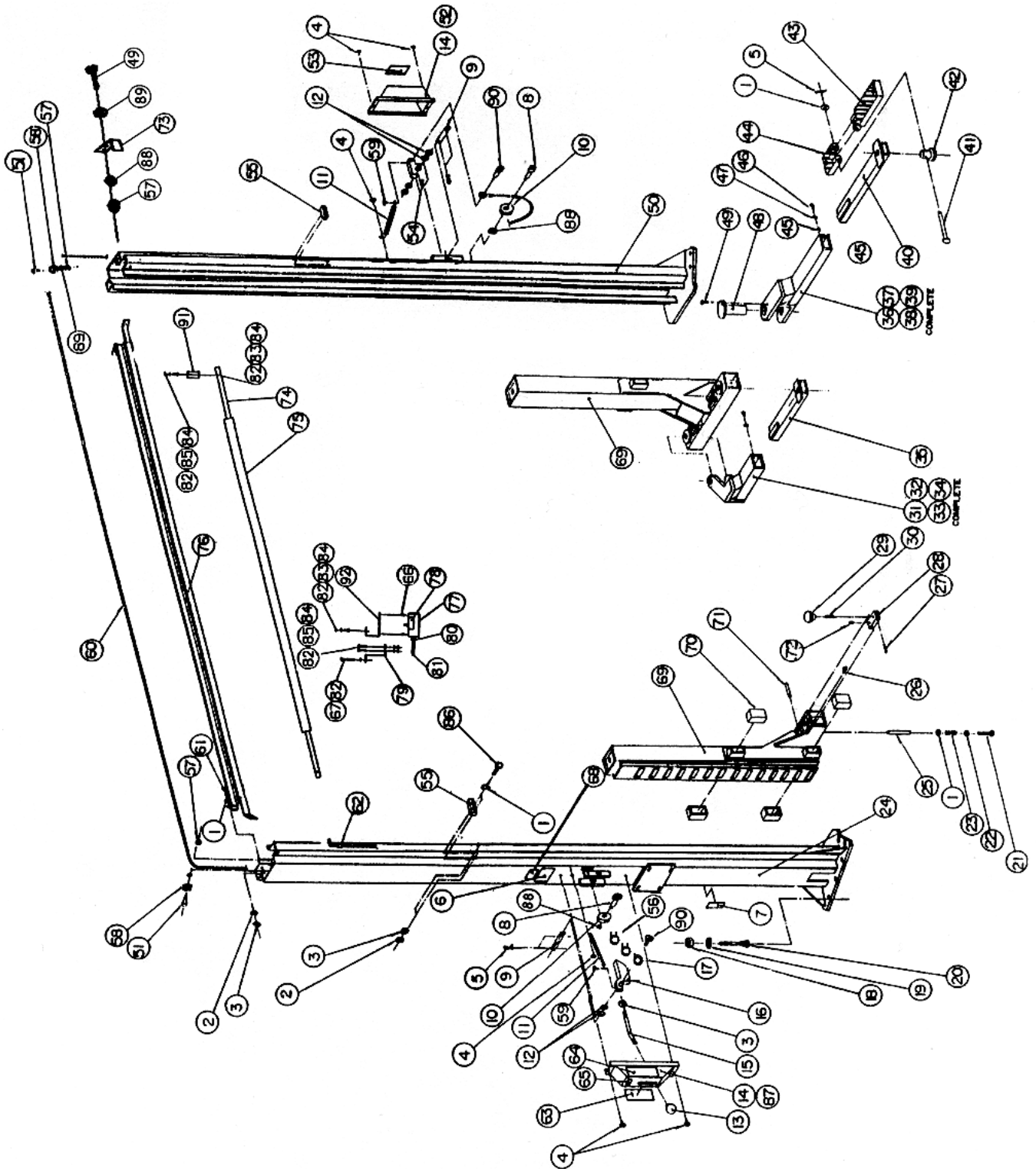

8.2 LIFT ASSEMBLY PARTS LIST

ITEM	QTY.	DESCRIPTION	PART #
1	20	FLAT WASHER, 1/2"ID SAE	6-0248
2	12	LOCKWASHER, 1/2"ID	6-0059
3	13	HEX NUT, 1/2"-13UNC	6-0035
4	6	SELF TAPPING SCREW, #12 x 1/2"LG.	6-1134
5	8	COTTER PIN, 1/8"DIA. x 1"LG.	6-0267
6	1	ALI/ETL DECAL	6-0996
7	1	"HYDRAULIC LEVELING" DECAL	6-1151
8	2	SHOULDER BOLT, 3/8"DIA. x 1"LG.	6-0206
9	2	SAFETY PIN	1-0938
10	2	SAFETY PULLEY	1-0415
11	2	SAFETY SPRING	1-1115
12	8	FLAT WASHER, 51/64"ID x 1"OD x 1/16"THK.	6-0808
13	1	PLASTIC KNOB	6-1135
14	2	SAFETY COVER	3-0439
15	1	SAFETY RELEASE HANDLE	1-1113
16	1	SAFETY DOG, LEFT SIDE	2-1901
17	1	5/32" THIMBLE	6-2074
18	14	HEX NUT, 3/4"-10UNC	6-0737
19	14	FLAT WASHER, 3/4"ID	6-0738
20	14	WEDGE ANCHOR, 3/4"-10UNC x 5 1/2"LG.	6-1379
21	4	HEX BOLT, 1/4"-20UNC x 3/4"LG.	6-0178
22	4	1/4"ID FENDER WASHER	6-0626
23	4	PLUNGER SPRING	1-0939
24	1	TOWER WELDMENT, LEFT SIDE	4-0381
25	4	PIVOT PLUNGER	1-0745
26	4	GREASE FITTING	6-0000
27	4	ROLL PIN, 1/8"DIA. x 1"LG.	6-0437
28	4	RACK	2-0249
29	4	KNOB	1-0208
30	4	THREADED ROD, 3/8"-16UNC x 1 1/2"LG.	1-1135
31	1	OUTER ARM TUBE WELDMENT, RIGHT SIDE	3-0561
32	1	OUTER ARM TUBE WELDMENT, LEFT SIDE	3-0562
33	1	LOCKING ARM ASSEMBLY, RIGHT SIDE	4-0464
34	1	LOCKING ARM ASSEMBLY, LEFT SIDE	4-0463
35	2	SHORT INNER ARM WELDMENT	2-1088
36	1	OUTER ARM TUBE WELDMENT, RIGHT SIDE	3-0560
37	1	OUTER ARM TUBE WELDMENT, LEFT SIDE	3-0559
38	1	LOCKING ARM ASSEMBLY, RIGHT SIDE	4-0462
39	1	LOCKING ARM ASSEMBLY, LEFT SIDE	4-0461
40	2	INNER ARM WELDMENT	2-1086
41	4	CENTER PIN	1-1099
42	4	ADAPTER PIN	1-1091
43	4	HIGH STEP POSITION ADAPTER	3-0582
44	4	LOW POSITION ADAPTER	3-0583
45	4	FLATWASHER, 3/8"I.D.	6-0062
46	4	HEX BOLT, 3/8"-16UNC x 3/4"LG.	6-0030
47	4	LOCKWASHER, 3/8"I.D.	6-0058
48	4	ARM PIN	2-0439

ITEM	QTY.	DESCRIPTION	PART #
49	6	HEX BOLT, 5/16"-18UNC x 3/4"LG.	6-0423
50	1	TOWER WELDMENT, RIGHT SIDE	4-0382
51	2	SHOULDER BOLT, 3/8"DIA. x 5/8"LG.	6-0069
52	1	SAFETY COVER w/DECALS, RIGHT SIDE	0-0203
53	1	"SAFETY INSTRUCTIONS" DECAL	6-0594
54	1	SAFETY DOG, RIGHT SIDE	2-0872
55	4	CARRIAGE STOP	1-1119
56	2	WIRE ROPE CLIPS	6-2060
57	4	HEX NUT, 5/16"-18UNC	6-0294
58	3	SAFETY CABLE PULLEY	1-1116
59	2	SELF TAPPING SCREW, #10 X 3/8" LG.	6-0169
60	1	SAFETY RELEASE CABLE	1-2058
61	4	HEX BOLT, 1/2"-13UNC x 1 1/2"LG.	6-0291
62	3	5/8" ELECTRICAL CLIP	6-1759
63	1	"WARNING" DECAL	6-0595
64	1	"CAUTION" DECAL	6-0592
65	1	"SAFETY RELEASE" DECAL	6-0603
66	2	6/32 SCREW (ELECTRICAL BOX)	6-1466
67	1	HEX HD. BOLT 1/4"NC x 2"LG.	6-0177
68	1	SERIAL # TAG	6-1120
69	2	CARRIAGE WELDMENT	4-0635
70	8	GLIDE BEARING	2-0772
71	4	PIVOT PIN	1-0333
72	4	SET SCREW., 1/4"-20UNC X 1/2"LG.	6-0438
73	2	ANGLE BRACKET	2-1477
74	1	ACTUATOR BAR	1-1380
75	1	FOAM GUARD	6-1404
76	1	CROSSMEMBER WELDMENT	3-0440
77	1	ELECTRICAL UTILITY BOX	6-1403
78	1	MICROSWITCH	6-0916
79	1	ACTUATOR EXTENSION	1-1379
80	1	CABLE CONNECTOR	6-1133
81	1	ELEC. CABLE 12/3 x 117"LG. SOW	6-1173
82	5	HEX HD. NUT 1/4"NC	6-0032
83	3	HEX HD. BOLT 1/4"NC x 3/4"LG.	6-0178
84	6	LOCKWASHER 1/4" DIA	6-0056
85	3	HEX BOLT 1/4" NC x 1 1/4" LG.	6-0027
86	8	HEX BOLT, 1/2"-13UNC x 2 1/4"LG.	6-0315
87	1	SAFETY COVER w/DECALS, LEFT SIDE	0-0204
88	4	FLAT WASHER, 5/16" I.D.	6-0295
89	4	LOCKWASHER, 5/16" I.D.	6-0296
90	2	SHOULDER BOLT, 3/8"DIA. x 1 1/2"LG.	6-0801
91	1	ACTUATOR MTG. BRACKET	1-1378
92	1	LIMIT SWITCH MTG. BRACKET	2-1143

8.3 HYDRAULIC SYSTEM

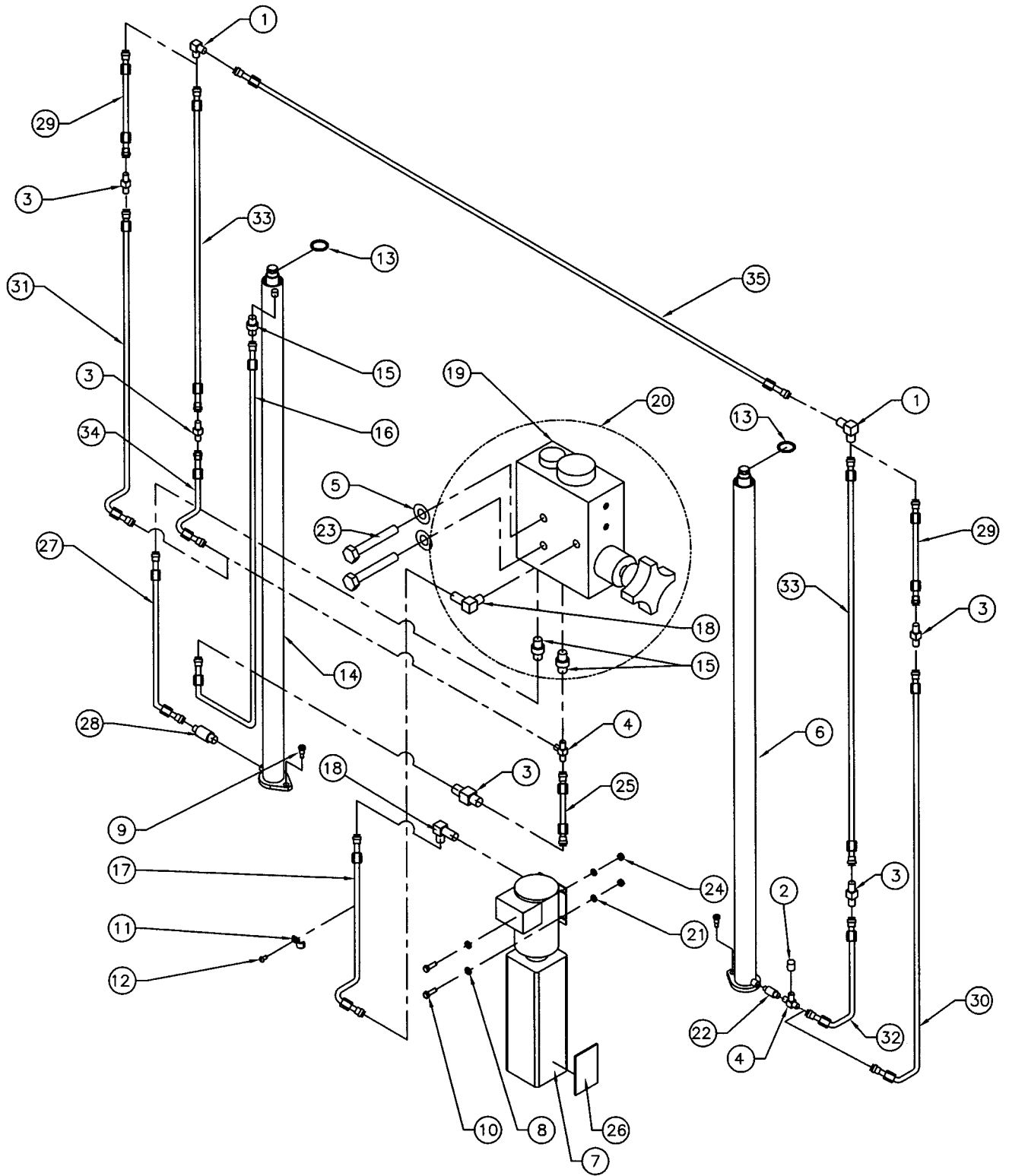

8.4 HYDRAULIC SYSTEM PARTS LIST

ITEM	QTY.	DESCRIPTION	PART #
1	2	ELBOW BULKHEAD 90°, 3/8"JIC-3/8"JIC	6-0012
2	1	CAP, 3/8"JIC	6-0021
3	3	UNION, 3/8"JIC MALE	6-0286
4	2	TEE, 3/8" SWIVEL NUT JIC MALE	6-0284
5	2	LOCKWASHER, 1/4" I.D.	6-0056
6	1	HYDRAULIC CYLINDER ASS'Y, RS	3-0735
7	1	POWER PACK (8K)	6-1956
	1	POWER PACK (9K)	6-1957
	1	POWER PACK (11K)	6-1935
8	4	FLAT WASHER, 5/16"ID	6-0295
9	2	SHOULDER BOLT, 1/2" x 5/8"LG.	6-0425
10	4	HEX BOLT, 5/16"-18UNC x 1"LG.	6-0293
11	7	TUBE CLAMP	6-0170
12	7	ROUND HD. BOLT, 1/4"-20UNC x 3/8"LG.	6-1353
13	2	CIRCLIP	6-0340
14	1	HYDRAULIC CYLINDER ASS'Y, LS	4-0289
15	2	ADAPTER, 1/4"NPT MALE - 3/8"JIC MALE	6-0276
16	1	HYDRAULIC TUBE ASS'Y, LS	2-0887
17	1	HYDRAULIC TUBE ASS'Y (VALVE BLOCK TO POWERPACK)	2-1140
18	2	ELBOW 90°, 9/16"SAE M-3/8"JIC M	6-0804
19	1	HYDRAULIC VALVE BLOCK	6-1362
20	1	HYDRAULIC VALVE BLOCK ASS'Y (C/W FITTINGS)	6-2623
21	4	LOCKWASHER, 5/16"ID	6-0674
22	1	ADAPTER, 3/8"NPT - 3/8"JIC x 2 1/4"LG.	6-0345
23	2	HEX HD. BOLT, 1/4"-20UNC x 1 3/4"LG.	6-0028
24	4	HEX NUT, 5/16"-18UNC	6-0294
25	1	HYDRAULIC TUBE ASS'Y	1-2436
26	1	"LIFT OPERATION" DECAL	6-2094
27	1	HYDRAULIC TUBE ASS'Y	2-0886
28	1	VELOCITY FUSE, 4GPM	6-0422
29	1	HYDRAULIC TUBE ASS'Y (2-PIECE TOWER)	2-0878
30	1	HYDRAULIC TUBE ASS'Y, RS (2-PIECE TOWER)	2-1876
31	1	HYDRAULIC TUBE ASS'Y, LS (2-PIECE TOWER)	2-1877
32	1	HYDRAULIC TUBE ASS'Y, RS (12' & 14' TOWER)	2-1874
33	1	HYDRAULIC TUBE ASS'Y, (12' TOWER)	2-1873
	1	HYDRAULIC TUBE ASS'Y, (14' TOWER)	2-1875
34	1	HYDRAULIC TUBE ASS'Y, LS	2-1872
35	1	HYDRAULIC TUBE ASS'Y (8/9K)	2-1537
	1	HYDRAULIC TUBE ASS'Y (11K ASS'Y)	2-0959
	1	HYDRAULIC TUBE ASS'Y (11K SYM)	2-1286
		GLAND SEAL KIT, RIGHT SIDE (8/9/11K)	0-0551
		PISTON SEAL KIT, RIGHT SIDE (8/9/11K)	0-0159
		GLAND SEAL KIT, LEFT SIDE (8/9/11K)	0-0206
		PISTON SEAL KIT, LEFT SIDE (8/9/11K)	0-0160

8.5 POWER PACK: #6-2055 (AB-1381) 208-230V/1PH/60Hz

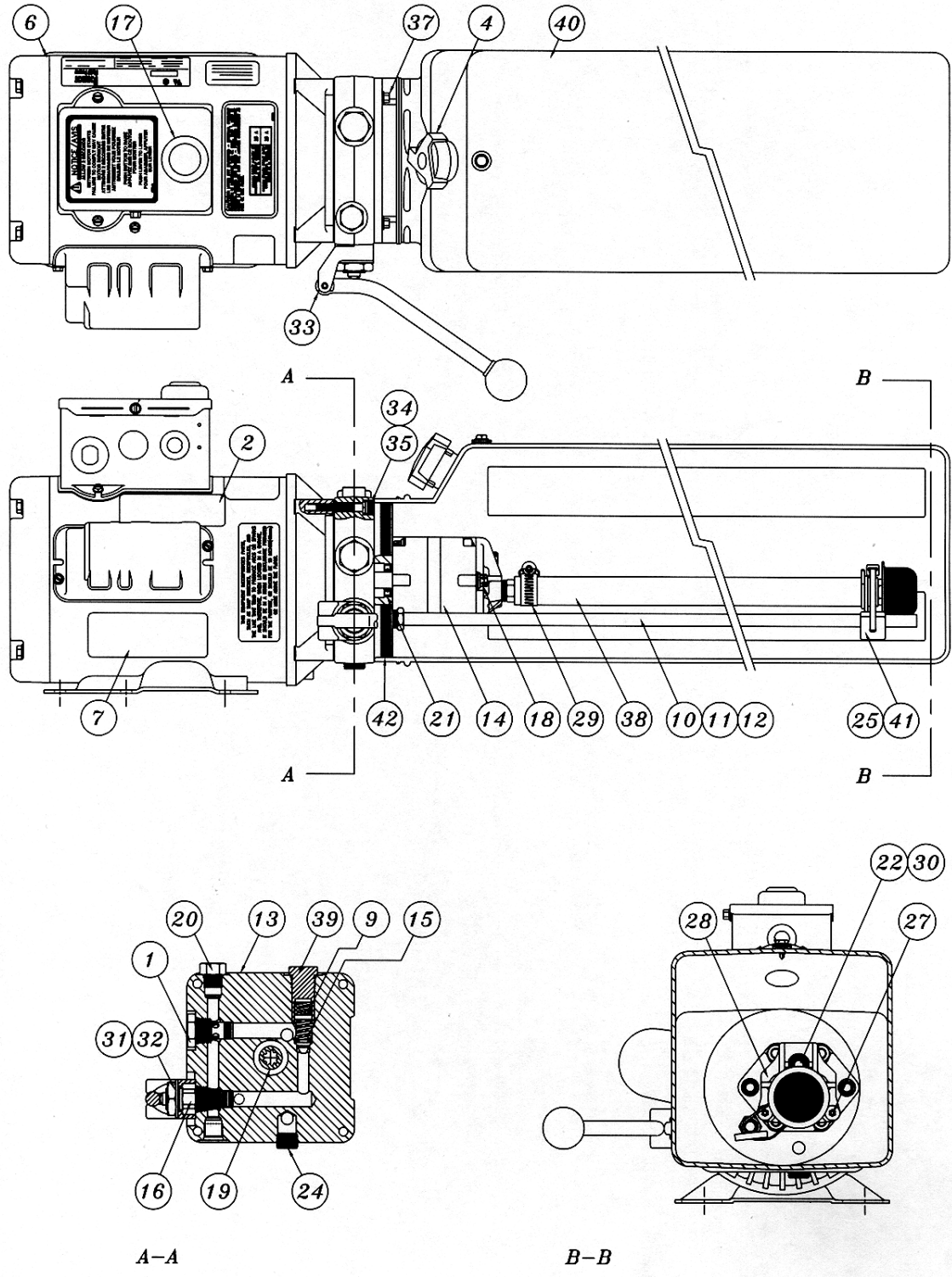

8.6 POWER PACK PARTS LIST: #6-2055 (AB-1381) 208-230V/1PH/60Hz

ITEM	QTY.	DESCRIPTION	PART #
1	1	VALVE CARTRIDGE CHECK	6-1087
2	1	LABEL INSTALLATION AUTOHOIST	6-2136
4	1	BREATHER CAP & BLADDER	6-1376
6	1	MOTOR AC 208-230V. 2HP/1PH/60Hz, BLK	6-2474
7	1	LABEL WARNING AUTOHOIST	6-2149
9	1	SPRING 0.480" x 0.063" x 0.42" COMP	6-2151
10	1	RETURN HOSE 3/8" OD x 21.5"	6-2152
11	1	COMPRESSION TUBE NUT	6-2153
12	1	COMPRESSION TUBE SLEEVE	6-2154
13	1	ENDHEAD UNIVERSAL AUTOHOIST	6-2155
14	1	PUMPASSY 2.5 CC/REV. SHORT SPLINE	6-1958
15	1	RELIEF ASSEMBLY FIXED 190 BAR	6-1319
16	1	VALVE CARTRIDGE RELEASE MANUAL	6-0880
17	1	WIRING ASSEMBLY AC 1PH FENNER	6-2473
18	2	BOLT 5/16"-24 x 3.00" TORX G8	6-1090
19	1	COUPLING SAE 9T-20/40 1.260"	6-0774
20	1	PLUMBING PLUG 9/16" SAE	6-2157
21	1	SEAL SHAFT 0.500" x 1.00" x 0.25"	6-2158
22	1	WASHER 0.338" x 0.625" x 0.060" STEEL	6-2159
24	1	PLUMBING PLUG 3/8" NPT	6-2161
25	1	PLUMBING MAGNET	6-2162
27	2	SCREW TAPTITE M6 x 1.0 12MM TORX	6-2164
28	1	COVER ASSY SUCTION	6-2165
29	1	PLUMBING CLAMP HOSE ADJ. INLET	6-2166
30	1	BOLT 5/16"-18 x 1.00" SHCS	6-1392
31	1	NUT 3/4"-16 x 1" HEX x 0.250" STEEL	6-2167
32	1	WASHER 3/4" INT. TOOTH LOCK	6-2168
33	1	BRACKET - HANDLE ASSY REL BLACK	6-0776
34	4	BOLT M6 x 1.0 35MM SOC HD	6-2169
35	4	WASHER 1/4" LOCK HI-COLLAR	6-2170
37	4	BOLT #12-24 x 0.50' HEX WSHRHD	6-1091
38	1	PLUMBING ASSY INLET 17.24 (3)	6-0786
39	1	RELIEF VALVE CAP ASSEMBLY	6-1089
40	1	TANK PLASTIC 6.7 OS 22.50" BLK	6-1399
41	1	CABLE TIE 8" LONG WHITE	6-1846
42	1	O-RING 2-348 BUNA	6-0875