

HOFMANN

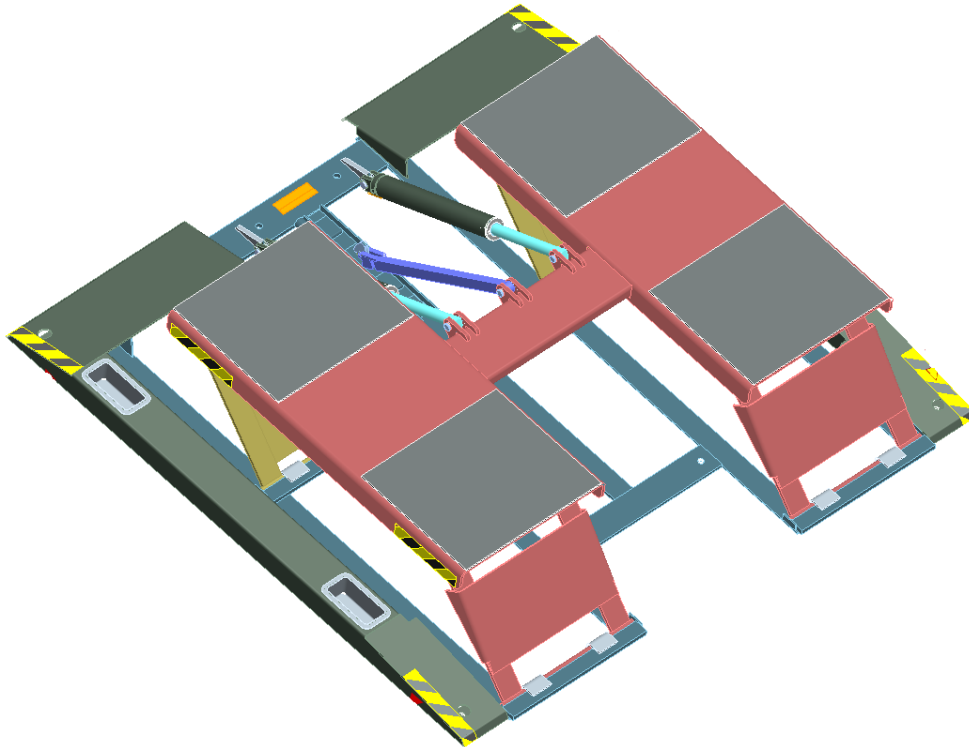

INSTALLATION and OPERATION MANUAL



10K LOWRISE EELR703A

**READ THIS INSTRUCTION MANUAL THOROUGHLY
BEFORE INSTALLING, OPERATING, SERVICING OR
MAINTAINING THE LIFT. SAVE THIS MANUAL.**



309 Exchange Avenue • Conway, AR 72032
(800) 251-4500 • (501) 505-2662
Fax (501) 450-2085 • www.hofmann-usa.com



6500 Millcreek Drive • Mississauga, ONT L5N 2W6
(800) 267-2185
Fax (905) 821-2073 • www.hofmann.ca

May 2013 REV.- 6-4013

TABLE OF CONTENTS

1	OWNER / EMPLOYER OBLIGATIONS	3
2	IMPORTANT SAFETY INSTRUCTIONS	4
3	SAFETY WARNING DECALS.....	7
4	GENERAL SPECIFICATIONS:	9
5	SHIPPING CONTENTS	10
6	TOOLS REQUIRED FOR INSTALLATION	10
7	INSTALLATION INSTRUCTIONS	10
7.1	BAY LAYOUT – SURFACE MOUNT	12
7.2	UNPACKING THE LIFT	13
7.3	HYDRAULIC CONNECTIONS.....	13
7.4	ANCHORING PROCEDURES.....	14
7.5	LINE COVER INSTALLATION (OPTIONAL)	15
8	USE OF LIFTING ADAPTER 2-2570	15
9	BLEEDING PROCEDURE	16
10	FINAL CHECK OF ASSEMBLED LIFT	16
11	OPERATION TEST WITH VEHICLE.....	16
12	LIFT OPERATION.....	17
12.1	Before Lifting:	17
12.2	Raising the Lift:.....	17
12.3	Lowering the Lift:	17
12.4	After Lowering:	17
13	RECOMMENDED MAINTANANCE	18
13.1	Inspect Regularly for:.....	18
13.2	MAINTANANCE SCHEDULE	18
14	TROUBLE SHOOTING	19
15	EMERGENCY OPERATION	19
16	LIFT ASSEMBLY.....	22
16.1	LIFT PARTS LIST.....	22
17	POWER PACK ASSEMBLY.....	23
17.1	POWER PACK PARTS LIST.....	24
18	AVAILABLE ACCESSORIES	25

1 OWNER / EMPLOYER OBLIGATIONS

1. The Owner/Employer shall ensure that lift operators are qualified and that they are trained in the safe use and operation of the lift using the manufacturer's operating instructions; ALI/SM 93-1, **ALI Lifting it Right safety manual**; ALI/ST-90 **ALI Safety Tips card**; ANSI/ALI ALOIM-2008, **American National Standard for Automotive Lifts - Safety Requirements for Operation, Inspection and Maintenance**; ALI/WL Series, **ALI Uniform Warning Label Decals/Placards**; and in the case of frame engaging lifts, ALI/LP-GUIDE, **Vehicle Lifting Points/Quick Reference Guide for Frame Engaging Lifts**.
2. The Owner/Employer shall establish procedures to periodically inspect the lift in accordance with the lift manufacturer's instructions or ANSI/ALI ALOIM-2008, American National Standard for Automotive Lifts - Safety Requirements for Operation, Inspection and Maintenance; and the Employer shall ensure that the lift inspectors are qualified and that they are adequately trained in the inspection of the lift.
3. The Owner/Employer shall establish procedures to periodically maintain the lift in accordance with the lift manufacturer's instructions or ANSI/ALI ALOIM-2008, American National Standard for Automotive Lifts - Safety Requirements for Operation, Inspection and Maintenance; and the Employer shall ensure that the lift maintenance personnel are qualified and that they are adequately trained in the maintenance of the lift.
4. The Owner/Employer shall maintain the periodic inspection and maintenance records recommended by the lift manufacturer's instructions or ANSI/ALI ALOIM-2008, American National Standard for Automotive Lifts - Safety Requirements for Operation, Inspection and Maintenance.
5. The Owner/Employer shall display the lift manufacturer's operating instructions; ALI/SM 93-1, ALI Lifting it Right safety manual; ALI/ST-90 ALI Safety Tips card; ANSI/ALI ALOIM-2008, American National Standard for Automotive Lifts - Safety Requirements for Operation, Inspection and Maintenance; ALI/WL Series, ALI Uniform Warning Label Decals/Placards; and in the case of frame engaging lifts, ALI/LP-GUIDE, Vehicle Lifting Points/Quick Reference Guide for Frame Engaging Lifts in a conspicuous location in the lift area convenient to the operator.
6. The Owner/Operator shall provide necessary lockout/tagout means for energy sources per ANSI Z244.1-1982 (R1993), Safety Requirements for the Lockout/Tagout of Energy Sources, before beginning any lift repairs and maintenance.
7. The Owner/Employer shall not modify the lift in any manner without the prior written consent of the manufacturer.

2 IMPORTANT SAFETY INSTRUCTIONS

When using this lift, basic safety precautions should always be followed, including the following (if applicable):

1. Read all instructions in this manual and on the lift thoroughly before installing, operating, servicing or maintaining the lift.
2. Care must be taken as burns can occur from touching hot parts.
3. Do not operate equipment with a damaged cord or if the equipment has been dropped or damaged – until it has been examined by a qualified service person.
4. Do not let a cord hang over the edge of the table, bench, or counter or come in contact with hot manifolds or moving fan blades.
5. If an extension cord is necessary, a cord with a current rating equal to or more than that of the equipment should be used. Cords rated for less current than the equipment may overheat. Care should be taken to arrange the cord so that it will not be tripped over or pulled.
6. Always unplug equipment from electrical outlet when not in use. Never use the cord to pull the plug from the outlet. Grasp plug and pull to disconnect.
7. Let equipment cool completely before putting away. Loop cord loosely around equipment when storing.
8. To reduce the risk of fire, do not operate equipment in the vicinity of open containers of flammable liquids (gasoline).
9. Adequate ventilation should be provided when working on operating internal combustion engines.
10. Keep hair, loose clothing, fingers, and all parts of body away from moving parts.
11. To reduce the risk of electric shock, do not use on wet surfaces or expose to rain.
12. Use only as described in this manual. Use only manufacturer's recommended attachments.
13. **ALWAYS WEAR SAFETY GLASSES.** Everyday eyeglasses only have impact resistant lenses, they are not safety glasses.
14. Inspect lift daily. Do not operate if it malfunctions or problems have been encountered.
15. Never attempt to overload the lift. The manufacturer's rated capacity is shown on the identification label on the power side column. Do not override the operating controls or the warranty will be void.

16. Before driving vehicle between the towers, position the arms to the drive-through position to ensure unobstructed clearance. Do not hit or run over arms as this could damage the lift and/or vehicle.
17. Only trained and authorized personnel should operate the lift. Do not allow customers or bystanders to operate the lift or be in the lift area.
18. Position the lift support pads to contact the vehicle manufacturers recommended lifting points. Raise the lift until the pads contact the vehicle. Check pads for secure contact with the vehicle. Check all arm restraints and insure they are properly engaged. Raise the lift to the desired working height.
19. Some pickup trucks may require an optional truck adapter to clear running boards or other accessories.
20. NOTE: Always use all 4 arms to raise and support vehicle.
21. **Caution!** Never work under the lift unless the mechanical safety locks are engaged.
22. Note that the removal or installation of some vehicle parts may cause a critical load shift in the center of gravity and may cause the vehicle to become unstable. Refer to the vehicle manufacturer's service manual for recommended procedures.
23. Always keep the lift area free of obstruction and debris. Grease and oil spills should always be cleaned up immediately.
24. Never raise vehicle with passengers inside.
25. Before lowering check area for any obstructions.
26. Before removing the vehicle from the lift area, position the arms to the drive-thru position to prevent damage to the lift and /or vehicle.
27. Do not remove hydraulic fittings while under pressure.
28. For additional safety instructions regarding lifting, lift types, warning labels, preparing to lift, vehicle spotting, vehicle lifting, maintaining load stability, emergency procedures, vehicle lowering, lift limitations, lift maintenance, good shop practices, installation, operator training and owner/employer responsibilities, please refer to "Lifting It Right" (ALI/SM) and "Safety Tips" (ALI/ST) and vehicle lift points for service garage lifting SAE J2184.
29. For additional instruction on general requirements for lift operation, please refer to "Automotive Lift-Safety Requirements For Operation, Inspection and Maintenance" (ANSI/ALI ALOIM).
30. Installation shall be performed in accordance with ANSO/ALI ALIS, Safety Requirements for Installation and Service of Automotive Lifts.



ATTENTION! This lift is intended for indoor installation only. It is prohibited to install this product outdoors. Operating environment temperature range should be 41 – 104 °F (5 – 40 °C). Failure to adhere will result in decertification, loss of warranty, and possible damage to the equipment.

+ 070126-Quadra-WLSIA01

SAFETY INSTRUCTIONS

If attachments, accessories or configuration modifying components that are located in the

load path, affect operation of the lift, affect the lift electrical listing or affect intended vehicle accommodation are used on this lift and, if they are not certified for use on this lift, then the certification of this lift shall become null and void. Contact the participant for information pertaining to certified attachments, accessories or configuration modifying components.

www.autolift.org

©2007 by ALI, Inc.

ALI / WLSIA01

SAVE THESE INSTRUCTIONS

3 SAFETY WARNING DECALS

Be sure the operator is aware and understands all safety warning labels and follows them accordingly.

<p>⚠ WARNING</p>  <p>Position vehicle with center of gravity midway between adapters. ©</p>	<p>⚠ WARNING</p>  <p>Remain clear of lift when raising or lowering vehicle. ©</p>	<p>⚠ WARNING</p>  <p>Keep feet clear of lift while lowering. ©</p>	
<p>⚠ WARNING</p>  <p>Clear area if vehicle is in danger of falling. ©</p>	<p>⚠ WARNING</p>  <p>Avoid excessive rocking of vehicle while on lift. ©</p>	<p>⚠ WARNING</p>  <p>Keep clear of pinch points when lift is moving. ©</p>	<p>The messages and pictographs shown are generic in nature and are meant to generally represent hazards common to all automotive lifts regardless of specific style.</p> <p>Funding for the development and validation of these labels was provided by the Automotive Lift Institute, P.O. Box 33116 Indianapolis, IN 46233.</p> <p>They are protected by copyright. Set of labels may be obtained from ALI or its member companies.</p> <p>© 1997 by ALI, Inc. ALIWE0306esm</p>
<p>⚠ CAUTION</p>  <p>Use vehicle manufacturer's lift points. ©</p>	<p>⚠ CAUTION</p>  <p>Always use safety stands when removing or installing heavy components. ©</p>	<p>⚠ CAUTION</p>  <p>Authorized personnel only in lift area. ©</p>	<p>⚠ CAUTION</p>  <p>Lift to be used by trained operator only. ©</p>
<p>SAFETY INSTRUCTIONS</p>  <p>Proper maintenance and inspection is necessary for safe operation. ©</p>	<p>SAFETY INSTRUCTIONS</p>  <p>Do not operate a damaged lift. ©</p>	<p>SAFETY INSTRUCTIONS</p>  <p>Read operating and safety manuals before using lift. ©</p>	<p>Power Unit: Secure placard near lift controls.</p>  <p>Lift Control Console: Secure placard in an accessible location.</p> 

CAUTION TAPE LOCATIONS

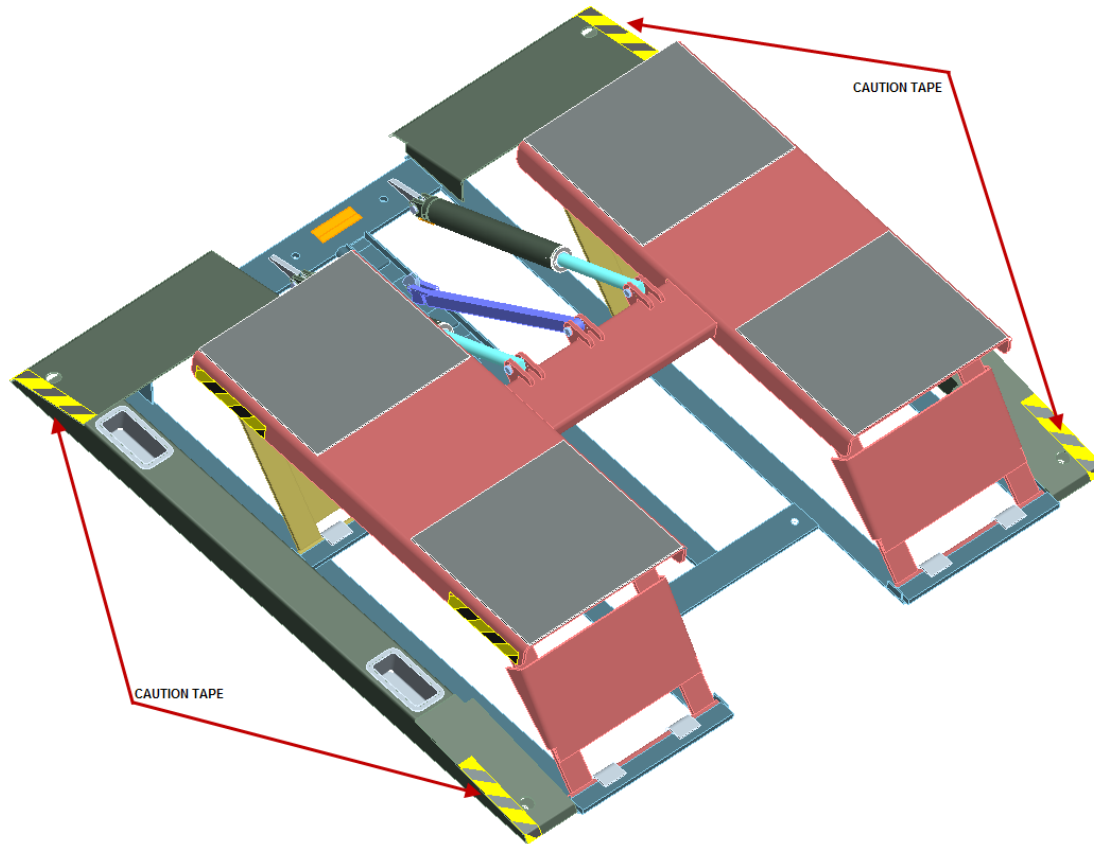

NOTE: CAUTION TAPE IDENTIFIES POSSIBLE TRIP HAZARDS WHEN THE LIFT IS LOWERED AND NOT IN USE. ENSURE THAT THIS TAPE IS REPLACED WHEN WORN OR REMOVED.

	<h1>WARNING</h1>
<p>SAFETY LATCH DOES NOT AUTOMATICALLY RESET, AFTER IT WAS DISENGAGED TO PERMIT LOWERING.</p> <p>LIFT HAS TO BE LOWERED COMPLETELY TO RESET LATCH.</p>	
<p>6-3996</p>	

4 GENERAL SPECIFICATIONS:

Capacity:
 Overall Width:
 Overall Length:
 Lowered Height:
 Raised Height:
 Power Requirements:
 Maximum Operating Pressure
 @ Rated Load:

10000 lbs.	4536 kg
85"	2159 mm
83"	2108 mm
3-7/8"	98 mm
21½"	546 mm
115 Volts AC, 1 Ph., 60 Hz.	
1600 psi	

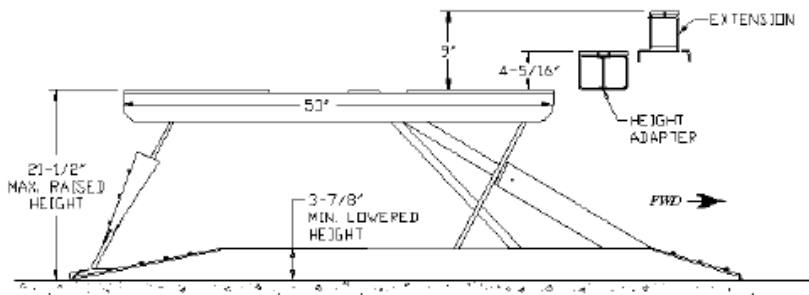
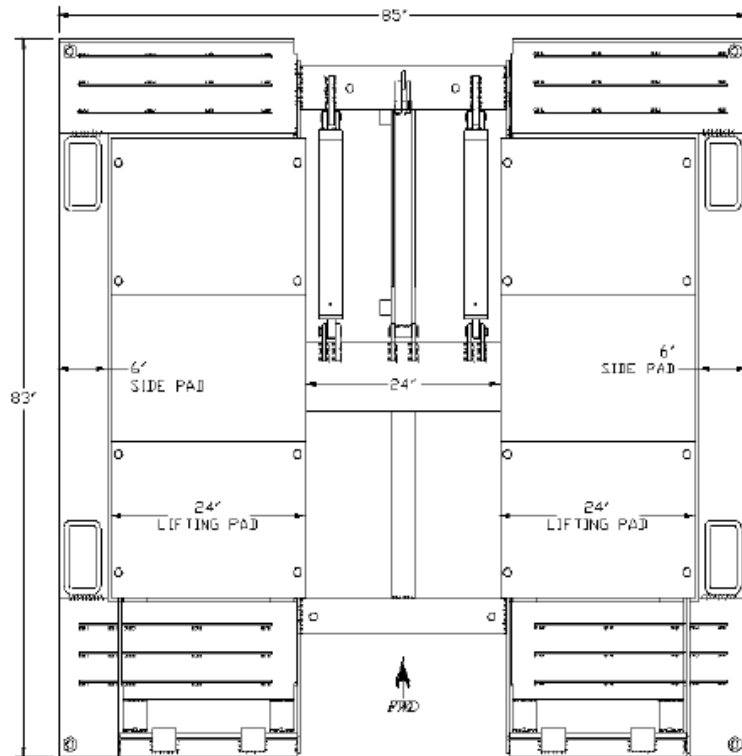

Figure 1 - Overall Specifications

5 SHIPPING CONTENTS

Overall Weight: 900lb / 408kg

- 1 – Lifting frame assembly with cylinders attached
- 1 – Pump box including:
 - 1 – Pumping unit assembly
 - 4 - 1/4" x 1 bolts with nuts & washers (Pump Mount)
 - 8 – 3/4" x 5 1/2" anchor bolts with nuts & washers (Frame Mount)
 - 1 – Tee fitting
 - 1 – Automotive lift safety tips
 - 1 – ALI manual "Lifting it Right"
- 1 – Installation and Operation manual
- 1 – Parts box including:
 - 4 – Height adapters
 - 4 – Height extensions
 - 2 – 1/4"x29" hydraulic hose
 - 1 – 3/8" x 20'hydraulic hose
- 1 – Pumping unit mounting stand

Missing Parts

It is important to notify the delivery carrier immediately if any parts are damages or missing from shipment.

6 TOOLS REQUIRED FOR INSTALLATION

- 16ft. Measuring Tape
- Chalk Line
- Rotary Hammer Drill
- 3/4" diameter Masonry Drill Bit
- Hammer
- SAE Wrenches and Ratchet Set
- 2ft. Level
- 4ft. Level
- Crow Bar
- 12ft. Step Ladder
- Side Cutters
- Screwdrivers
- 4" x 4" Wooden Blocks (for unpacking)

7 INSTALLATION INSTRUCTIONS

When the lift arrives on site, please read the owner's manual completely and make sure the installation instructions are fully understood. Check the contents of

the hardware and accessory boxes to make sure no parts are missing and no freight damages exist before starting installation. Gather all the tools listed above and make sure the installation instructions are fully understood before commencing with the installation.

IMPORTANT: It is the user's responsibility to provide a satisfactory installation area for the lift. Lifts should only be installed on level concrete floors with a minimum thickness of 4-1/4" or 108 mm. Concrete must have a steel reinforcing with a minimum strength of 3000 psi or 21 MPa and should be aged thirty (30) days prior to installation. Maximum slope must not exceed 1/16" per foot. Always pay special attention to the condition of the concrete such as age, cracking, chipping, and levelness. Please consult the architect, contractor or engineer if doubt exists as to the strength and feasibility of the floor to enable proper lift installation and operation.

A qualified person should be consulted to address seismic loads and other local or state requirements.

It is the user's responsibility to provide all wiring for electrical hook-up prior to installation and to insure that the electrical installation conforms to local building codes. Where required, it is the user's responsibility to provide an electrical isolation switch located in close proximity to the lift that will enable emergency stop capability and isolate electrical power from the lift for any servicing requirements.

7.1 BAY LAYOUT – SURFACE MOUNT

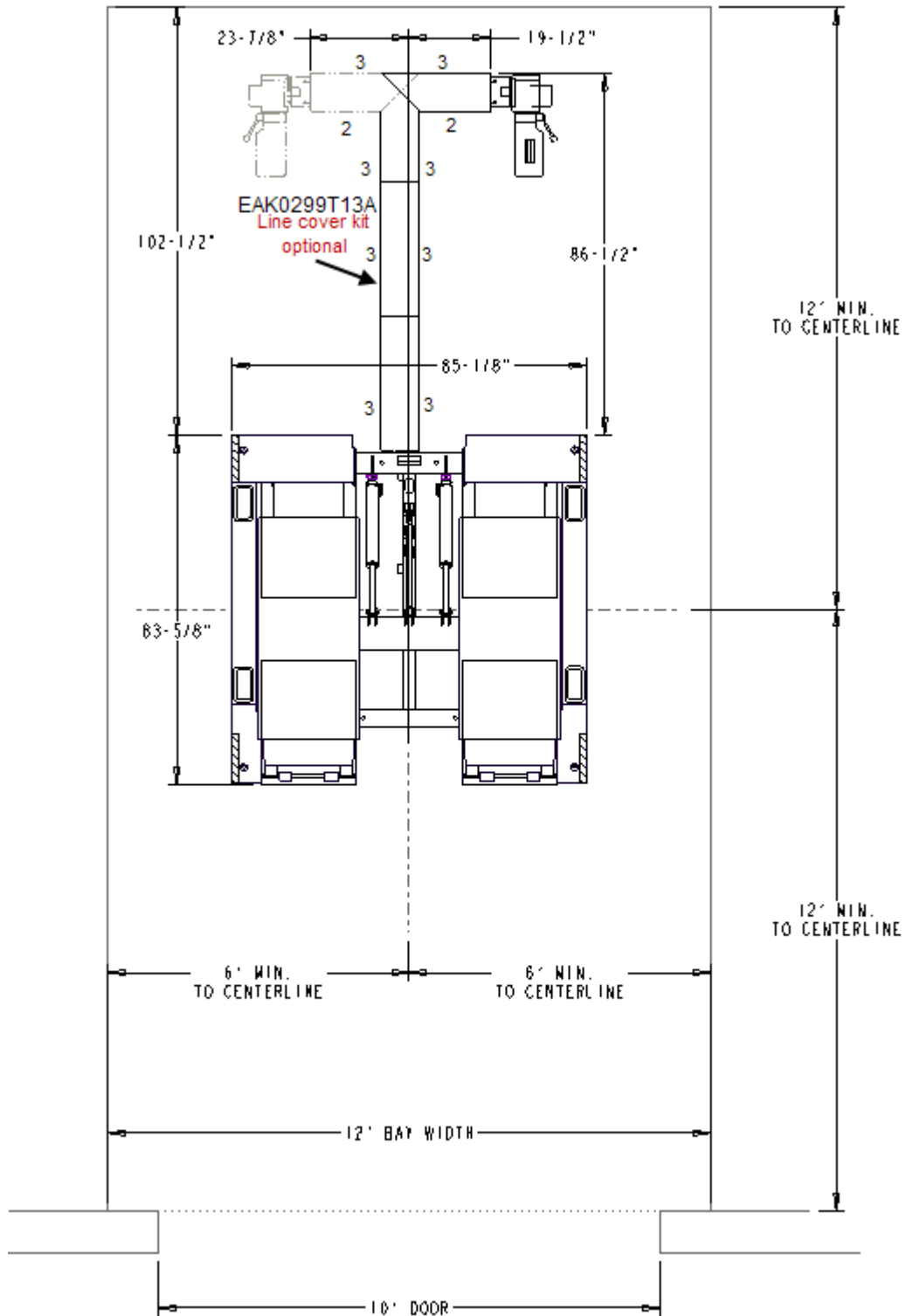

Figure 2 - Bay Layout – Surface Mount
NOTE: LAYOUT SHOWN WITH OPTION LINE COVER KIT EAK0299T13A

7.2 UNPACKING THE LIFT

Remove the metal strapping from the main structure package and slide the lift shipping skid. Open the accessory box and check the contents of the box.

1. Position unit on a flat floor allowing a minimum of 6 feet from center of lift to side obstructions and 12 feet from center of lift to front or rear obstructions. (Lift cylinder is on front end of lift.) Recommended overhead clearance is a minimum 97 inches ceiling providing 25 inches for the maximum lift height and 6 feet for the supported vehicle. For vehicles taller than 6 feet it is recommended that the user provides additional overhead clearance or a shut off mechanism to stop the lift from raising the vehicle too high.
2. Remove pumping unit from box and install on pump stand.

7.3 HYDRAULIC CONNECTIONS

NOTE: When working with hydraulics it is important to keep all components clean.

1. Select a position best suited for the power pack.
2. Remove the breather filler cap and fill with 11 liters / 3 Gal. of ISO 32 10 weight hydraulic oil.
3. Reinstall the breather filler cap onto the Power Unit.
4. Connect the 90° elbow fitting (9/16" JIC-M, 3/8" JIC-M) with 'O' ring, to the hydraulic outlet port on the valve assembly of the power pack. The 90° elbow fitting is located in a hardware kit.
5. Connect 11' (3353 mm) long hydraulic hose (female end) to the opposite end of the 90° elbow fitting.
6. Locate the opposite (male) end of the 11' (3353 mm) long hydraulic hose. Connect to the central end of the swivel tee.
7. Connect the male ends from both 29" long hydraulic hoses to the swivel tee side ends. Locate the opposite (female) ends of both 29" long hydraulic hoses and connect them to the inlet ports of the lift, which are located on the corresponding hydraulic cylinders.
8. Tighten the hydraulic line in place so that it runs along the floor giving it a low profile.

7.4 ANCHORING PROCEDURES

NOTE: Check operation of lift (up/down) before anchoring the lift.

1. Using a rotary hammer drill and a 1/2" concrete bit, drill through the floor at each anchor bolt location. Make sure that the 1/2" concrete drill bit is in good condition.
2. Clean out the drilling dust from the holes
3. Assemble the nut and washer onto the supplied 1/2" x 4-1/2" long wedge anchor bolts. A minimum of six threads must be visible below the surface of the nut.
4. Hammer in the anchors until they make contact with the base plate. **Hand tighten all anchor bolts.** Remove any bolt assembly that does not grip concrete firmly and open expansion sleeve before reinstalling.
5. Inspect to make certain lift sits firmly on floor. There should be no twisting or rocking motion in the base unit.
6. Torque all anchor bolts to 40 ft-lbs.
7. Position the power pack in the final desired location. Using a rotary hammer drill and a 1/4" concrete bit, drill four (4) holes and anchor the power pack stand to the floor using anchor bolts located in the hardware kit.
8. Install the optional line covers to protect hydraulic hoses, refer to section 7.2
9. With all anchor bolts torqued as specified operate the lift checking its full operation.

If anchor bolts do not tighten to 40 ft-lbs OR project more than 2 1/4" above the concrete surface, the concrete should be replaced by an appropriate concrete pad. (Consult Product Manufacturer / Supplier for further details.)

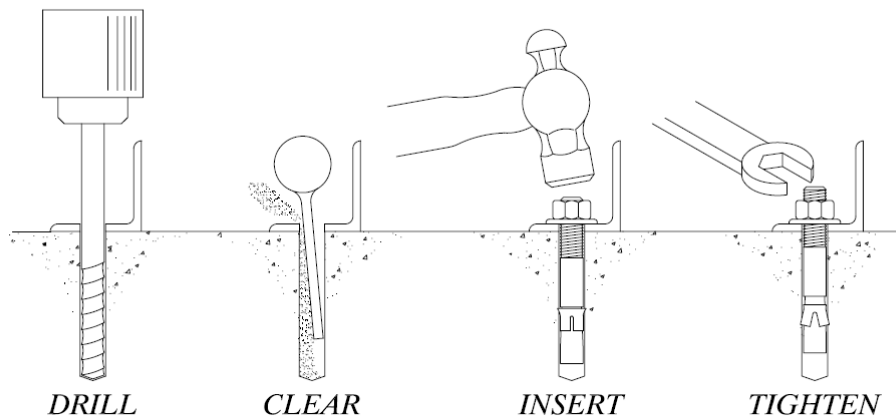

Figure 3 - Anchoring Steps

7.5 LINE COVER INSTALLATION (OPTIONAL)

NOTE: FLOOR COVERS ARE DESIGNED TO SUPPORT FOOT TRAFFIC AND TOOL BOXES UNDER 300LBS. ANY VEHICLE TRAFFIC WILL CAUSE DAMAGE TO THE LINE COVERS.

1. Position the power pack in the location shown in the Bay layout Figure 2
2. Use the combination of straight (2-2736) and angled (2-2734 and 2-2733) line covers provided in the options line cover kit EAK0299T13 to cover the hoses from the structure to the power pack. Any excess hydraulic hose should be coiled and zip tied to the power pack stand to avoid trip hazards.
3. The angled line covers 2-2733 and 2-2734 will need to be cut at the cut line shown in figure 2.
- 4.
5. Using a ¼" concrete drill bit, drill and fasten the line covers to the floor using the ¼" x 1" long nail in anchors provided. The number beside the line covers represent the quantity of fasteners required to secure that side. Ensure that the line covers are sitting securely on the floor.
6. NOTE: If the lift is shimmed to a point where the line covers do not sit flush due to interference with hoses, the line covers can be heated with a heat gun and then placed over the hoses for a cleaner look.

8 USE OF LIFTING ADAPTER 2-2570

NOTE: Please read the warning label on adapters 2-2570 before use.

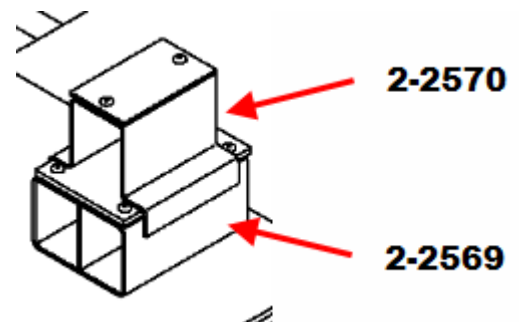

Figure 4 - Adapter Assembly

9 BLEEDING PROCEDURE

1. Press the up control button and raise the lift 10" (254mm) above the ground.
2. Lower the lift to the ground and hold the down button until lift fully reaches the ground.
3. Repeat these steps 3-4 times to completely bleed the system of air. Check the lift for hydraulic leaks at all connections.
4. After bleeding, it is recommended that the filter assembly fitting (between the hydraulic hose and the power pack be cleaned. Place the fitting on a workbench and use an air gun to blow through the filter in the opposite direction to flow from the lift.

10 FINAL CHECK OF ASSEMBLED LIFT

- Check for hydraulic leaks. _____
- Ensure all safety lock mechanisms are working correctly. _____
- Re-check level of decks. _____
- Check all fasteners, tighten if necessary. _____
- Operate lift to full stroke then lower to ground while checking
for proper functionality. _____
- Ensure Customer Care Kit is complete and given to operator. _____
- Operation Manual _____
- ANSI / ALI Lift It Right Manual _____
- ANSI / ALI Safety Tip CARD _____
- ANSI / ALI ALIS safety Requirements for Installation
and Service of Automotive Lifts _____
- ANDI / ALI Quick Reference Guide _____
- Train end user on operation of the lift. _____

11 OPERATION TEST WITH VEHICLE

1. Lower lift to ground.
2. Drive vehicle on to lift such that the lift's contact frame is properly aligned with the manufacturer's recommended lifting points for that vehicle.
3. Raise lift to and lower onto first, second, and third lock positions during full rise to ensure all locks are working correctly.
4. Check lowering speed and smooth decent rate.
5. Lower lift to ground and drive vehicle off lift.

If any problems occur during the final checkout or operation of the lift please contact customer service at 1-800-268-7959.

12 LIFT OPERATION

Operators of this lift should be trained by authorized personnel.

12.1 Before Lifting:

1. After making certain lift is in the fully lowered position, drive the vehicle into the bay and position it with the wheel in front of the superstructure.

NOTE: The center of gravity of the vehicle should be centered on the lifting structure. Refer to the "Lifting it Right" and "Vehicle lifting points quick reference Guide" ALI/LP Guide provided. SAE J2184

DO NOT TURN STEERING WHEEL WHILE TIRES ARE CROSSING

2. Check to make certain car is fairly well centered left to right on lift.

12.2 Raising the Lift:

Hold toggle switch on pumping unit in "ON" position until locking leg drops onto one of the three lifting height locking positions.

Rock vehicle to check for stability.

Lower the vehicle onto the mechanical locks.

12.3 Lowering the Lift:

1. After making certain lifting area is clear of people, electric cords, hoses, etc., raise lift past next the safety lock to full height to disengage locking device.
2. Press the lowering handle slowly until the lift is in its fully collapsed position.

	<h1>WARNING</h1>
<p>SAFETY LATCH DOES NOT AUTOMATICALLY RESET, AFTER IT WAS DISENGAGED TO PERMIT LOWERING.</p> <p>LIFT HAS TO BE LOWERED COMPLETELY TO RESET LATCH.</p>	
<small>6-3996</small>	

12.4 After Lowering:

Drive car off lift without turning steering wheel while tires are crossing the lift.

13 RECOMMENDED MAINTANANCE

13.1 Inspect Regularly for:

- Overload cracks in welds and metal fatigue.
- Misalignment of working parts.
- Hydraulic leaks.
- Low fluid level in pump reservoir. **DO NOT** use automatic transmission fluid. Use only petroleum based ISO 32-10 weight hydraulic oil.
- Lubricate all moving parts.
- Check locking latch for smooth and proper operation.

13.2 MAINTANANCE SCHEDULE

Daily:

1. Check all hydraulic lines and fittings for pinch points , damage , cracks or leaks
2. Check all electrical wiring for pinch points , cracks or damage
3. Check all moving parts for uneven or excessive wear
4. Repair or replace all damaged, defective, worn or broken components immediately.
5. Check the telescopic arms for movement. Clean any grease or oil from the lifting adapters.
6. Raise and lower the lift at the beginning of each shift, without a vehicle on, to verify the lift is leveled and operating properly.
7. Check the operation of the mechanical safety lock and release mechanism. If any damage or malfunction is found, discontinue using the lift until repair is performed.

Weekly:

- Check and adjust hydraulic level.

Every Two Months:

- Clean and re-grease hinge pins.

Every Year:

- Inspect lift as per Automotive Lift Operation, Inspection and Maintenance (ALOIM).
-

Every Two Years:

- Change hydraulic fluid.

LUBRICATION:

- Where grease is required multi-purpose lithium grease.
- Where lubricating oil is required > multi-purpose SAE 30 lubricating oil.
- Where hydraulic oil is required > ISO 32 10W - non detergent hydraulic oil.

14 TROUBLE SHOOTING

1. Motor does not run:
 - A. Breaker tripped or fuse blown.
 - B. Motor thermal overload tripped. Wait for overload to cool.
 - C. Defective control switch. Replace switch.
 - D. Faulty wiring connections. Call electrician.
2. Motor runs but the lift will not hold a load:
 - A. A foreign object under check valve. Push handle down and push “raise” switch. Foreign matter should release under pressure.
 - B. Remove check valve. Clean ball and seat and replace the nut.
 - C. Oil level low, check oil reservoir. With lift cylinder (cylinders) in the down position, pump reservoir should be full.
3. Motor runs but the lift picks up partial load only.
 - A. Lift is overloaded. Check capacity of lift and weight of vehicle.
 - B. Relief valve setting is too low. Remove back hex cap on pump and adjust valve clockwise.
 - C. Hydraulic seals damaged (call customer service for instructions 1-800-266-7959).
4. Lift makes groaning sound when raising or lowering.
 - A. Bleed cylinder manually.
 - B. Add an ounce of oil to the air side of the piston.

15 EMERGENCY OPERATION

If the lift becomes inoperative in the raised position, it is best to wait until the electrical power is restored before lowering the vehicle. However, if it's critical to safety that the lift be lowered, the following steps should be taken:



WARNING: DO NOT LOOSEN OR REMOVE HYDRAULIC CONNECTIONS OR FITTINGS UNDER PRESSURE. SERIOUS INJURY OR DEATH COULD OCCUR.

NOTE: Safely performing this process requires 2 people. All personnel should stay clear of the path of the lift. All tools and other non-secured items should be removed from the surface of the runways.

- 1) Survey the area surrounding the lift; remove any items and personnel from area before proceeding with this procedure.
- 2) Perform the appropriate lockout/tag out procedure on the electrical energy.
- 3) Use a second person standing at a safe distance away from the lift to keep watch on the area, lift, vehicle and other personnel throughout the process. This person should signal the person performing the procedure to stop if necessary.
- 4) Use a caution tape or similar to barrier the area around the lift to avoid personnel from accidentally entering the area while this process is being performed.
- 5) Do not proceed with this procedure if you are unfamiliar with the lift or its function.

IF THE MECHANICAL LOCK IS NOT ENGAGED:

- 1) Verbally indicate to all those involved that the lift will now be lowered.
- 2) Perform a visual inspection on the status of the safety cam. Do not attempt to walk under the lifted vehicle for this inspection, lean on the vehicle, or seek support on any of its parts. If the position of the cam is like in Case A, you may continue with instructions at points (3), (4), (5). If the position of the cam is like in Case B, the safety lock will engage as lift continues to descend. Points (3), (4), (5) do not apply. Proceed to next case: "IF THE Mechanical Stop IS ENGAGED".

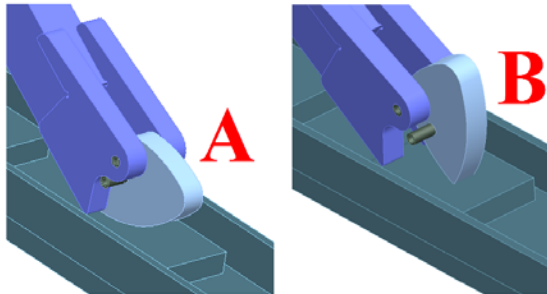

- 3) Slowly push the lowering lever on the power pack to lower the lift.
- 4) Keep a close eye on the movement of the lift and the position of the vehicle; release the lowering lever if any abnormal movement is detected.

- 5) Once power is restored follow the lockout/tag out procedure to return the lift back into service.

IF THE MECHANICAL LOCK IS ENGAGED:

Various methods can be used to raise the lift until the mechanical lock disengages (at maximum rise). The safest method would employ temporary electrical power to the lift using a portable power generator. Any electrical connections should be done by a licensed electrician; lock out/tag out procedures should also be employed at this time.

This process should only be performed by a trained professional. Contact customer service or a local service professional for further assistance.

16 LIFT ASSEMBLY

NOTE: Only replace parts with genuine lift manufacturers supplied parts

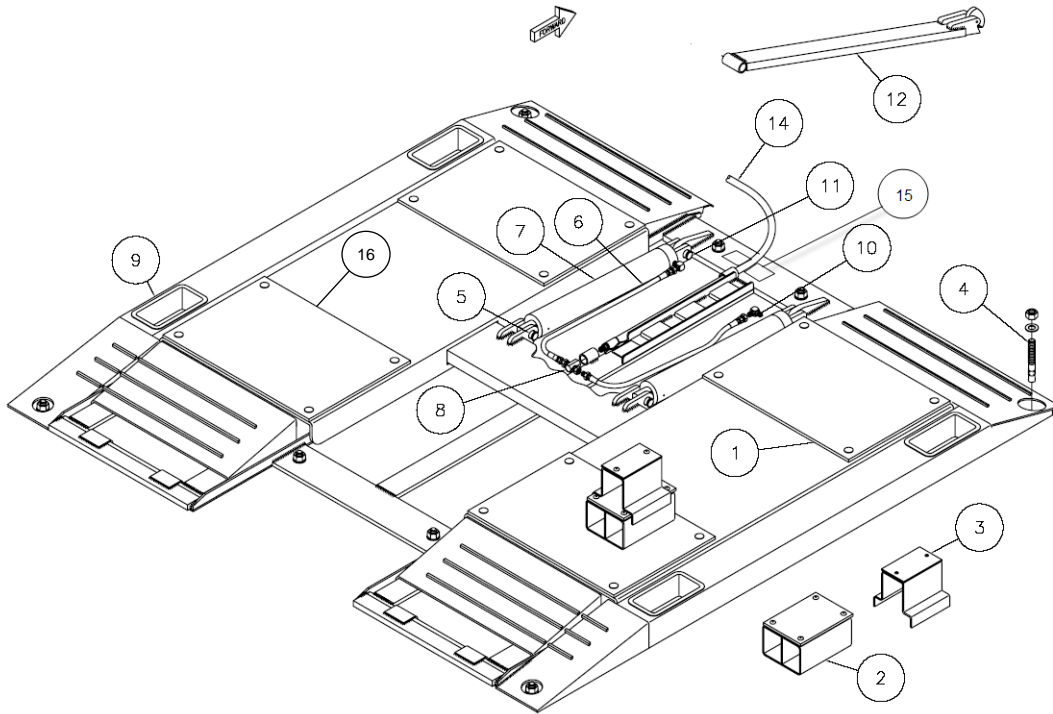

16.1 LIFT PARTS LIST

Item	Part No.	Description	QTY.
1	2-3002	3/8" x 19" x 22-1/2" Front Pad	2
2	2-2569	4" Height Extension Adapter	4
3	2-2987	4-1/2" Height Extension Adapter	4
4	6-1379	3/4" x 5-1/2" Anchor Bolt	4
5	1-3806	7/8" x 2-3/4" Piston Top Axle	2
6	2-2561	1/4" x 29" Hydraulic Hose M-F	2
7	3-1068	Cylinder Assembly	2
8	6-3516	F Pipe x F Pipe Swivel Tee 6-4-4	1
9	1-3374	Plastic Lug Nut Box	4
10	6-4018	Flow restrictor	2
11	1-3805	3/4" x 2-7/16" Pin	2
12	3-1066	Lock Leg Assembly	1
14	2-2566	11' High Pressure Hose	1
16	2-3003	3/8" x 19" x 22-1/2" Rear Pad	2
	3-1026	Pump Stand Bolt Down Standard	1

* Not shown in figure.

17 POWER PACK ASSEMBLY

NOTE: Only replace parts with genuine lift manufacturer's supplied parts

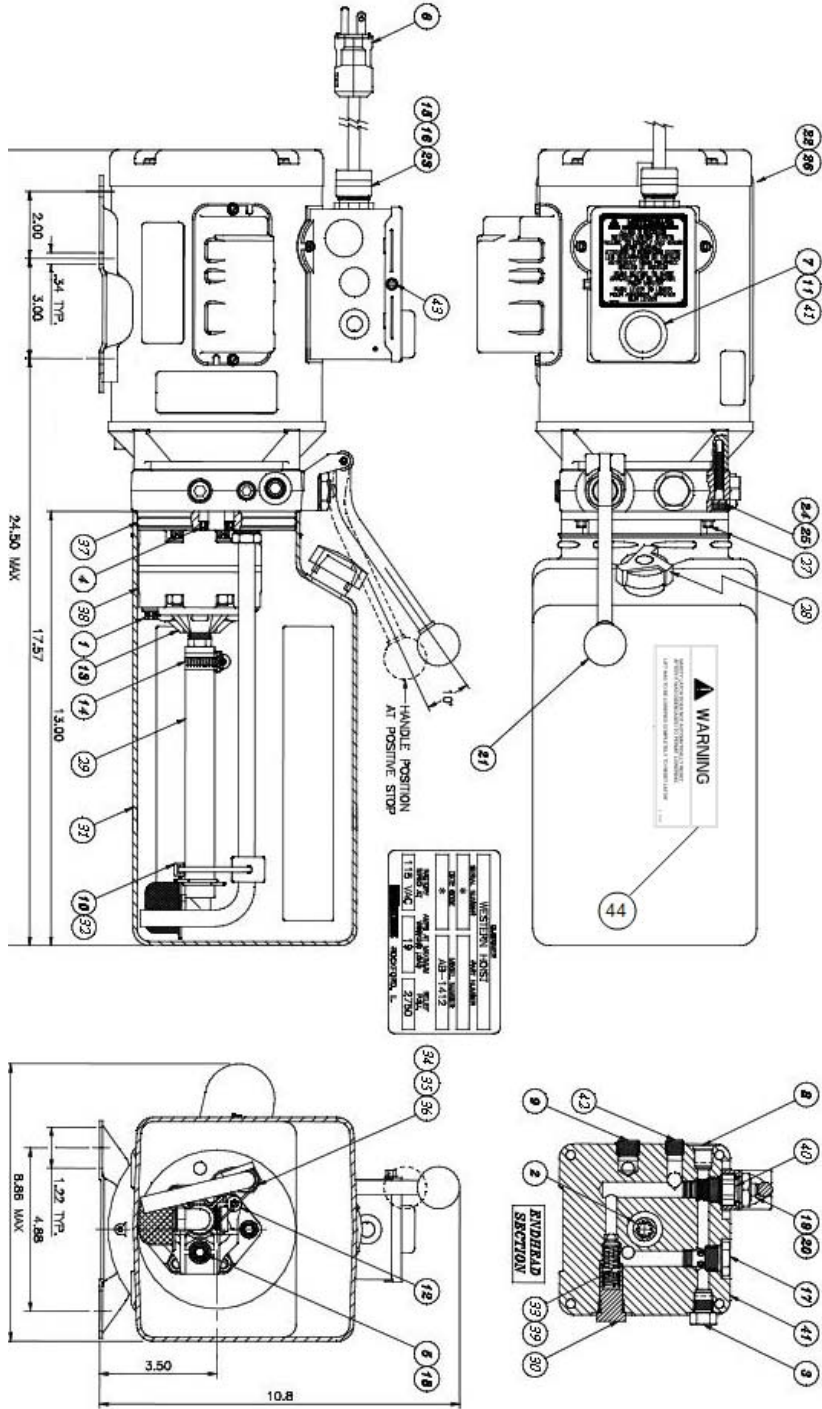

17.1 POWER PACK PARTS LIST

Item	Part No.	Description
1	6-2298	BOLT, 5/16" - 24" X 2-3/4" LG
2	6-0774	COUPLING (4 POST POWER PACK)
3	6-2157	PLUMBING PLUG 5/16" SAE
4	6-2158	SEAL SHAFT 0.5X1X.25
5	6-2159	WASHER .338X.625X.06
6	62300	CORDSET 16/3 SJO 8FT 115V PLUG
7	6-2156	WIRING ASSEMBLY AC 1PH FENNER
8	6-2301	PACKAGE PLUG 9/16" SAE
9	6-2157	PLUMBING PLUG 9/16 SAE
10	6-2162	PLUMBING MAGNET
11	6-2302	ELECTRICAL STAKON NUT
12	6-2164	SCREW TAPTITE TORX
13	6-2165	COVER ASY SUCTION
14	6-2166	CLAMPHOSESEADJ. INLET
15	6-2303	ELECTRIC CORD GRIP 3/4"NPT
16	6-2304	ELECTRIC PIPENUT 3/4"
17	6-1087	VALVE CARTRIDGE CHECK
18	6-2305	VALVE LOAD DELAY
19	6-2167	NUT 3/4"-16x1" HEX .25
20	6-2168	WASHER 3/4" INT TOOTH
21	6-1108	RELEASE HANDLE ASS'Y
22	6-3782	END HEAD UNIV.
23	6-2311	ELECT. REDUCER WASHER
24	6-2169	SHCS, M6X1 .35MM
25	6-2170	WASHER 1/4 LC HI-COLLR
26	6-2600	MOTOR(2781-BC)115/230V,1PH,1HP
27	6-1091	RESERVOIR SCREW
28	6-1376	BREATHER FILLER
29	6-0884	INLET HOSE/FILTER ASS'Y
30	6-1089	RELIEF VALVE CAP
31	6-3783	TANK 2.0 GAL WHITE
32	6-1846	CABLE TIE 8" LONG WHITE
33	6-1319	RV19
34	6-2153	COMPRESSION TUBE NUT
35	6-2154	COMP. TUBE SLEEVE
36	6-3786	RETURN TUBE 1/2 OD 90 DEG
37	6-0875	RESERVOIR O-RING
38	6-2306	PUMP ASS'Y 0.8 SHORT SPLINE
39	6-2151	SPRING .48X.063X.42
40	6-0880	VALVE CARTRIDGE RELEASE MANUAL
41	6-2156	MICROSWITCH W/SNAP LID W-200
42	6-2161	PLUMB. PLUG 3/8NPT
43	6-3466	GROUNDING SCREW, #8-32 X 1/2"
44	6-3996	DECAL

18 AVAILABLE ACCESSORIES

2-2733 qty 1

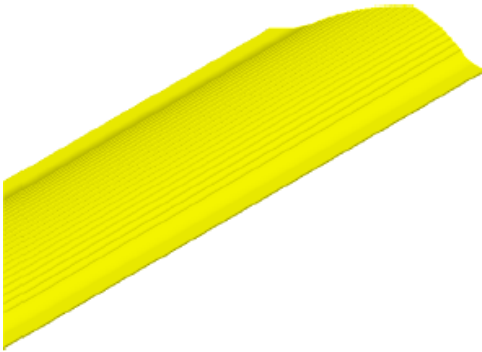

2-2734 qty 1

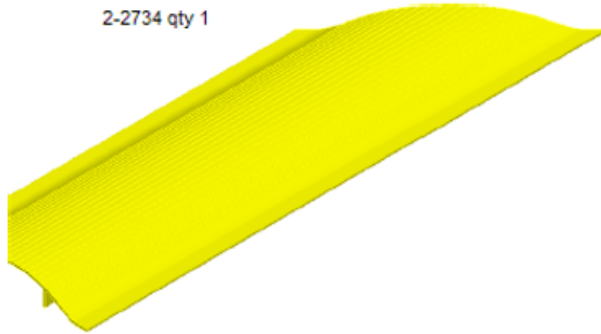

2-2736 qty 3

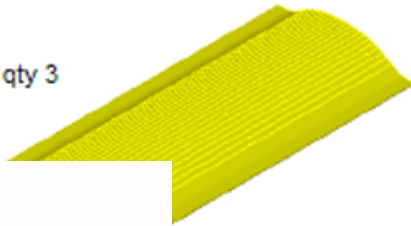

Figure 4 – Square Pad, Part No. 6-2776 (Set of 4)



Rubber

EAK0299T13A - Line Cover Kit