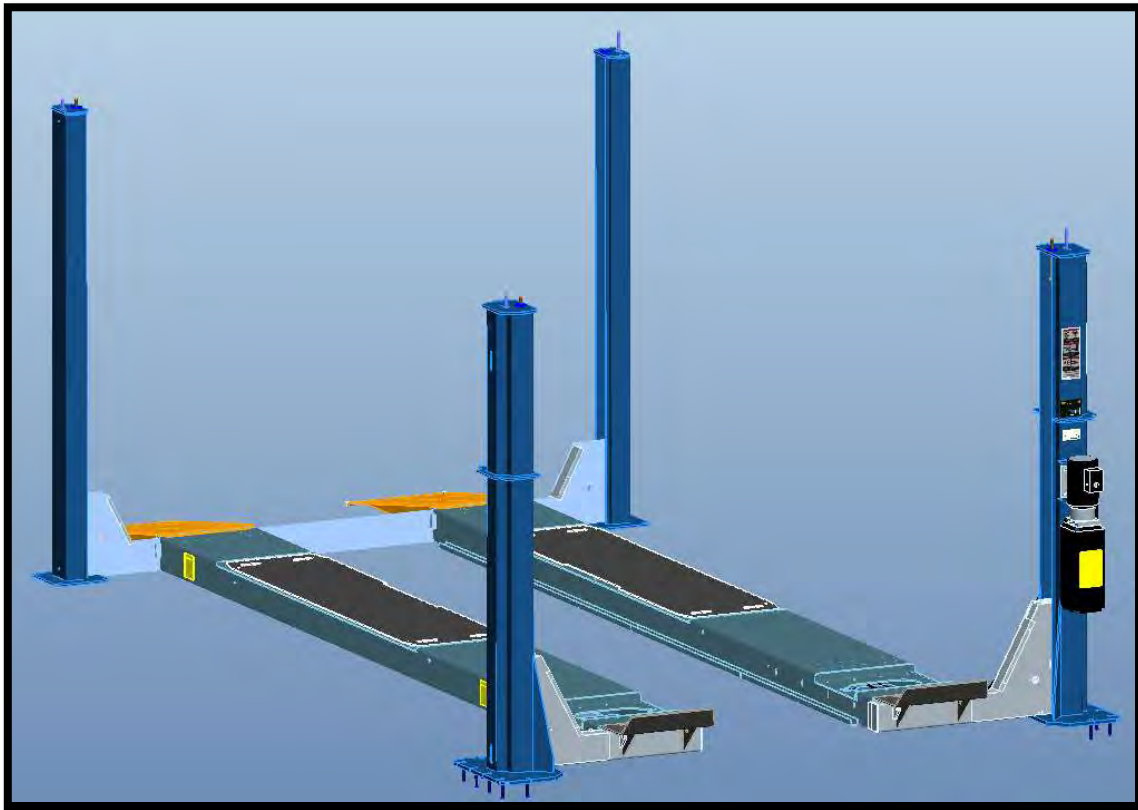




a division of **Snap-on Equipment**

# INSTALLATION and OPERATION MANUAL



## **4-POST 14000 LBS. EELR705A, EELR707A**

**READ THIS INSTRUCTION MANUAL THOROUGHLY BEFORE  
INSTALLING, OPERATING, SERVICING OR MAINTAINING THE  
LIFT. SAVE THIS MANUAL.**



309 Exchange Avenue • Conway, AR 72032  
(800) 251-4500 • (501) 505-2662  
Fax (501) 450-2085 • [www.hofmann-usa.com](http://www.hofmann-usa.com)



6500 Millcreek Drive • Mississauga, ONT L5N 2W6  
(800) 267-2185  
Fax (905) 821-2073 • [www.hofmann.ca](http://www.hofmann.ca)

REV.- SEPT 27 2018

6-4042

## OWNER / EMPLOYER OBLIGATIONS

1. The Owner/Employer shall ensure that lift operators are qualified and that they are trained in the safe use and operation of the lift using the manufacturer's operating instructions; ALI/SM 93-1, **ALI Lifting it Right** safety manual; ALI/ST-90 **ALI Safety Tips** card; ANSI/ALI ALOIM-2017, **American National Standard for Automotive Lifts - Safety Requirements for Operation, Inspection and Maintenance, Appendix A (Operator Training Log)**; ALI/WL Series, **ALI Uniform Warning Label Decals/Placards**; and in the case of frame engaging lifts, ALI/LP-GUIDE, **Vehicle Lifting Points/Quick Reference Guide for Frame Engaging Lifts**.
2. The Owner/Employer shall establish procedures to periodically inspect the lift in accordance with the lift manufacturer's instructions or ANSI/ALI ALOIM-2017, **American National Standard for Automotive Lifts - Safety Requirements for Operation, Inspection and Maintenance, Appendix B and Appendixes C through F**; and the Employer shall ensure that the lift inspectors are qualified and that they are adequately trained in the inspection of the lift.
3. The Owner/Employer shall establish procedures to periodically maintain the lift in accordance with the lift manufacturer's instructions or ANSI/ALI ALOIM-2017, **American National Standard for Automotive Lifts - Safety Requirements for Operation, Inspection and Maintenance, Appendix G (Planned Maintenance Log)**; and the Employer shall ensure that the lift maintenance personnel are qualified and that they are adequately trained in the maintenance of the lift.
4. The Owner/Employer shall maintain the periodic inspection and maintenance records recommended by the lift manufacturer's instructions or ANSI/ALI ALOIM-2017, **American National Standard for Automotive Lifts - Safety Requirements for Operation, Inspection and Maintenance**
5. The Owner/Employer shall display the lift manufacturer's operating instructions; ALI/SM 93-1, **ALI Lifting it Right** safety manual; ALI/ST-90 **ALI Safety Tips** card; ANSI/ALI ALOIM-2017, **American National Standard for Automotive Lifts - Safety Requirements for Operation, Inspection and Maintenance**; ALI/WL Series, **ALI Uniform Warning Label Decals/Placards**; and in the case of frame engaging lifts, ALI/LP-GUIDE, **Vehicle Lifting Points/Quick Reference Guide for Frame Engaging Lifts** in a conspicuous location in the lift area convenient to the operator.
6. The Owner/Operator shall provide necessary lockout/tagout means for energy sources per ANSI Z244.1-1982 (R1993), **Safety Requirements for the Lockout/Tagout of Energy Sources**, before beginning any lift repairs and maintenance.
7. The Owner/Employer shall not modify the lift in any manner without the prior written consent of the manufacturer.

---

**⚠ WARNING** DO NOT ATTEMPT TO OPERATE THIS LIFT IF ANY PART IS NOT WORKING PROPERLY OR YOU HAVE NOT READ THE COMPLETE OPERATING INSTRUCTION MANUAL.

---

## 1.1 IMPORTANT SAFETY INSTRUCTIONS

When using this lift, basic safety precautions should always be followed, including the following:

1. Only trained and authorized personnel should operate the lift or rolling jacks. Do not allow customers or bystanders to operate the lift or be in the shop area while lift is in use.
2. Read all instructions in this manual and on the lift. Thoroughly train all employees in the use and care of lift and rolling jacks.
3. Inspect lift daily. Do not operate if it malfunctions or problems have been encountered.
4. Ensure no one is standing in front or behind the lift while vehicle is being driven onto, or backed off the lift.
5. Before driving vehicle on, make sure lift is in the fully down position.
6. Before removing the vehicle from the lift, make sure the lift is in the fully down position and ensure that all tools have been removed from the deck surfaces.
7. Always raise the lift off safety locks before lowering.
8. Do not allow rear tires or portion of the vehicle to interfere with approach ramp.
9. Be sure front wheel stops are always installed on the lift.
10. Never allow front wheels to strike the front wheel stops.
11. Do not permit employees or customers on lift when it is either being raised or lowered.
12. Never raise vehicle with passengers inside.
13. Always stand clear of lift when raising or lowering and observe “Pinch points” warning.
14. Before lowering the lift, check area for any obstructions
15. Never attempt to overload the lift. The manufacturer’s rated capacity is shown on the identification label on the power side column.
16. Do not override the operating controls or safety mechanisms, or the warranty will be void. The mechanical safeties are designed to engage automatically on the way up.
17. Always use wheel chocks to keep the vehicle from rolling freely on the runways. Wheel chocks should be used at the front and back of the same wheel.
18. Always use Personal Protective Equipment (PPE) when installing or servicing the lift.
- 19. Caution! Never work under the lift unless the mechanical safety locks are engaged.**
20. Always keep the lift area free of obstruction, tools and debris. Grease and oil spills should always be cleaned up immediately.
21. Always keep runways clean.
22. To protect against the risk of fire, do not operate lift in the vicinity of open containers of flammable liquids.
23. Adequate ventilation should be provided when working on internal combustion engines.
24. Replace all caution, warning, or safety related decals on the lift when unable to read or missing.
25. For Rolling Jack Safety Instructions, see Rolling Jack Installation, Operation and Maintenance Instructions in the Rolling Jack box.

**SAFETY INSTRUCTIONS**

If attachments, accessories or configuration modifying components that are located in the load path, affect operation of the lift, affect the lift electrical listing or affect intended vehicle accommodation are used on this lift and, if they are not certified for use on this lift, then the certification of this lift shall become null and void. Contact the participant for information pertaining to certified attachments, accessories or configuration modifying components.

www.autolift.org ©2007 by ALI, Inc. ALI / WLSIAO1

+ 070126-Quadra-WLSIAO1

## 1.2 SAFETY WARNING LABELS FOR 4-POST SURFACE MOUNTED ROLL-ON LIFTS

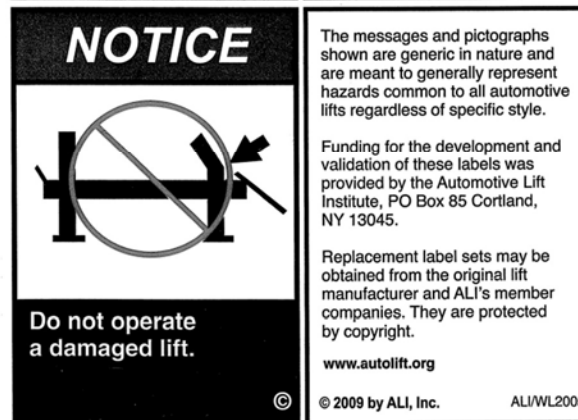
### Automotive Lift Institute, Inc.



The messages and pictographs shown are generic in nature and are meant to generally represent hazards common to all automotive lifts regardless of specific style.

Funding for the development and validation of these labels was provided by the Automotive Lift Institute, PO Box 85 Cortland, NY 13045.

Replacement label sets may be obtained from the original lift manufacturer and ALI's member companies. They are protected by copyright.  
[www.autolift.org](http://www.autolift.org) © 2009 by ALI, Inc. ALI/WL200c



### WL200 Series Label Kit



The messages and pictographs shown are generic in nature and are meant to generally represent hazards common to all automotive lifts regardless of specific style.

Funding for the development and validation of these labels was provided by the Automotive Lift Institute, PO Box 85 Cortland, NY 13045.

Replacement label sets may be obtained from the original lift manufacturer and ALI's member companies. They are protected by copyright.  
[www.autolift.org](http://www.autolift.org) © 2010 by ALI, Inc. ALI/WL200w

**SAVE THESE INSTRUCTIONS**

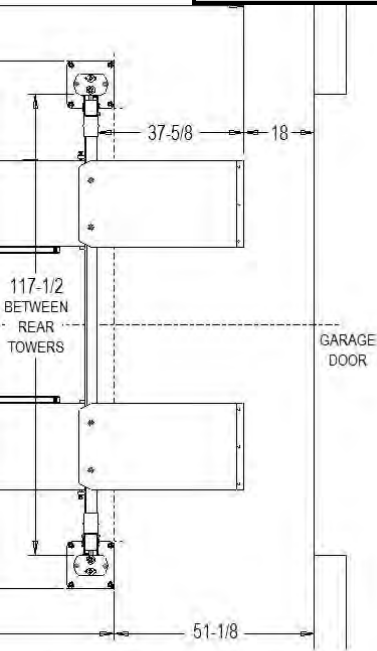
## 2. TABLE OF CONTENTS

<b>1. OWNER / EMPLOYER OBLIGATIONS.....</b>	<b>2</b>
1.1 IMPORTANT SAFETY INSTRUCTIONS .....	3
1.2 SAFETY WARNING LABELS FOR 4-POST SURFACE MOUNTED ROLL-ON LIFTS.....	4
<b>2. TABLE OF CONTENTS.....</b>	<b>5</b>
<b>3. GENERAL SPECIFICATIONS.....</b>	<b>7</b>
<b>4. TOOLS REQUIRED FOR INSTALLATION.....</b>	<b>8</b>
<b>5. PACKAGING CONTENTS.....</b>	<b>8</b>
<b>6. INSTALLATION INSTRUCTIONS.....</b>	<b>10</b>
6.1 CHALK LINE LAYOUT .....	11
6.2 IDENTIFICATION OF MAIN LIFT COMPONENTS.....	11
6.3 FRONT CROSS-MEMBERS AND TOWER ASSEMBLIES .....	13
6.4 ANCHOR FRONT TOWERS.....	17
6.5 DECK ASSEMBLIES (FRONT) .....	18
6.6 REAR CROSS-MEMBER AND TOWER ASSEMBLIES.....	19
6.7 DECK ASSEMBLIES (REAR).....	21
6.8 CABLE INSTALLATION.....	23
6.9 SAFETY RELEASE AIR LINES.....	26
6.10 INSTALL SHEAVES. FINALIZE CABLE INSTALLATION.....	27
6.11 POWER PACK AND HYDRAULIC HOSE INSTALLATION .....	30
6.12 MOUNTING LIGHTS & LOCKS CONTROL BOX (OPTIONAL).....	31
6.13 JACKING BEAM AIR LINE .....	32
6.14 FRONT AND REAR LIGHT KIT CONNECTIONS (OPTIONAL).....	33
6.15 FINALIZE AIR LINE INSTALLATION.....	34
6.16 FINALIZE LIGHTS & LOCKS INSTALLATION (OPTIONAL).....	35
6.17 LOCKING FRONT TURNPLATES & REAR SLIP PLATES (OPTIONAL) .....	37
6.18 FILTER/REGULATOR/LUBRICATOR COMMISSIONING (OPTIONAL) .....	38
6.19 ELECTRICAL CONNECTIONS.....	38
6.20 LIGHTS & LOCKS CONTROL BOX (OPTIONAL) .....	40
6.21 LIGHTS & LOCKS CONTROLS (OPTIONAL).....	42
6.22 DECK LEVELING PROCEDURE .....	43
6.23 ANCHOR REAR TOWERS.....	44
6.24 APPROACH RAMPS, WHEEL STOPS, PULLEY COVERS.....	46
<b>7. OPERATING INSTRUCTIONS .....</b>	<b>47</b>
<b>8. RECOMMENDED INSPECTION AND MAINTENANCE.....</b>	<b>48</b>
8.1 LUBRICATION SPECS .....	48
8.2 WIRE ROPES .....	50
8.3 FASTENERS .....	52
8.4 SHEAVES AND PINS.....	52
8.5 MECHANICAL SAFETY LATCHES (DOGS).....	53
8.6 CABLE BREAK SAFETY MECHANISM.....	53
8.7 AIR CYLINDERS, AIR LINES, VALVE AND FITTINGS .....	53
8.8 HYDRAULIC POWER PACK AND HOSE.....	54
8.9 HYDRAULIC CYLINDER .....	54
8.10 RUNWAYS.....	54
8.11 COLUMNS .....	55
8.12 APPROACH RAMPS, CHOCKS, FRONT WHEEL STOPS .....	55
8.13 FRONT AND REAR STEER PLATES.....	55
8.14 ROLLING AIR JACKS.....	56
8.15 ENTIRE LIFT.....	56
<b>9. LIFT LOCKOUT / TAGOUT PROCEDURE .....</b>	<b>57</b>

9.1	PURPOSE .....	57
9.2	RESPONSIBILITY .....	57
9.3	PREPARATION .....	57
9.4	SEQUENCE OF LOCKOUT PROCEDURE .....	57
9.5	RESTORING EQUIPMENT TO SERVICE .....	57
9.6	RULES FOR USING THE LOCKOUT PROCEDURE .....	57
<b>10.</b>	<b>PARTS LIST .....</b>	<b>58</b>
10.1	PARTS LIST - LIFT ASSEMBLY .....	58
10.2	PARTS LIST – FRONT TOWER ASSEMBLY, POWER .....	60
10.3	PARTS LIST – REAR CROSS-MEMBER .....	61
10.4	EXPLODED VIEW - LOCKS & LIGHTS (OPTIONAL).....	62
10.5	PARTS LIST – FRONT CROSS-MEMBER, LS.....	63
10.6	PARTS LIST – FRONT CROSS-MEMBER, RS .....	64
10.7	PARTS LIST - DECK ASSEMBLY, LEFT SIDE.....	65
10.8	EXPLODED VIEW - LOCKS & LIGHTS (OPTIONAL).....	66
10.9	PARTS LIST - DECK ASSEMBLY, RIGHT SIDE .....	68
10.10	EXPLODED VIEW - LOCKS & LIGHTS (OPTIONAL).....	69
10.11	PARTS LIST – CYLINDER ASSEMBLY – P/N: 4-1353 .....	71
10.12	ARTS LIST - CABLE ROUTING .....	71
10.13	PARTS LIST - AIR AND HYDRAULICS .....	72
10.14	FILTER/REGULATOR/LUBRICATOR ASSEMBLY .....	73
10.15	PARTS LIST - POWER PACK .....	74
10.16	EXPLODED VIEW - LOCKS & LIGHTS (OPTIONAL).....	76
10.17	POWER SUPPLY FRAME ASSEMBLY (OPTIONAL).....	78
10.18	EXPLODED VIEW - LOCKS & LIGHTS (OPTIONAL).....	80
10.19	MAINTENANCE RECORD .....	81

### 3. GENERAL SPECIFICATIONS

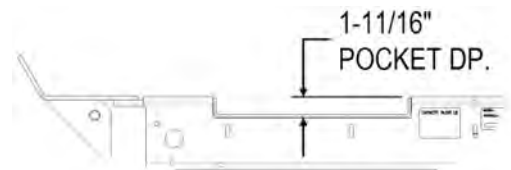
Maximum Capacity	14,000 lb	6350 kg
Maximum Wheelbase – General Service	205”	5207 mm
Maximum Wheelbase – 2-Wheel Alignment	188”	4775 mm
Maximum Wheelbase – 4-Wheel Alignment	158”	4013 mm
Minimum Wheelbase – 4-Wheel Alignment	70”	1778 mm
Overall Length	270-5/8”	6874 mm
Overall Width	140 1/2”	3569 mm
Lowered Runway Height	7”	178 mm
Maximum Lifting Height (to runway surface)	74”	1879 mm
Rise Time	70 Seconds	
Ramp approach angle (no shims)	10°	
Power Requirements	Standard motor	230VAC, 1PH., 20A, 60 Hz
	Optional motor	208-230/460VAC, 3PH., 9A, 60 Hz
Shipping Weight	4206lb	1908 kg
Maximum Operating Pressure (Full Load):	3180 psi	219 bar



turn table, and adjust this dimension accordingly.

**NOTE:**

Dimensions in *Figure 1* and *Figure 2* are reference dimensions, It is critical to ensure that front cross-members are positioned during installation as defined in *Figure 14* at page 17.



**Figure 1**

#### 4. TOOLS REQUIRED FOR INSTALLATION

ROTARY HAMMER DRILL  
3/4" CONCRETE DRILL BIT  
1/2" CONCRETE DRILL BIT  
4' LEVEL  
HAMMER (for anchor installation)  
PRY BAR (for shim installation)  
CHALK LINE (lift location)  
TAPE MEASURE  
ELECTRICAL TAPE  
STEP LADDER (adjusting cables and/or safety ladder in posts)  
SIDE CUTTERS (for cutting shipping straps)  
4 WORK STANDS (set up)  
STANDARD SOCKETS AND WRENCHES  
ALLEN KEY SET  
SCREWDRIVER SET  
FLOOR JACK OR ENGINE HOIST  
BOX CUTTER / SNIPS (to remove packaging)  
RUBBER OR PLASTIC MALLET

#### 5. PACKAGING CONTENTS

The lift is packaged to protect it from damage during shipping. The two deck assemblies and cross-members are packaged together with the accessory boxes strapped to them.

##### Main Structural Components:

- 1 - Left Side Deck Assembly (complete with hydraulic cylinder)
- 1 - Right Side Deck Assembly
- 1 - Front LS Cross-member Assembly (with air cylinder release locks)
- 1 - Front RS Cross-member Assembly (with air cylinder release locks)
- 1 - Rear Cross-member Assembly (with air cylinder release locks)

**Table 1: Accessory Box Contents**

Hardware Kit (with separate packaging list)	1
Top plate, Front Towers	2
Top plate, Rear Towers	2
Cross-Member Sheave Pins	4
Deck Sheave Pin	5
Sheave Weldment/Assembly	11
Spacer, Sheave, 1-11/16" Lg.	2
Spacer, Sheave, 3-3/16"	1
Spacer, Sheave, 1/4" Lg.	1



Spacer, Sheave, 1” Lg.	3
Spacer, Sheave, 2-1/4” Lg.	2
Spacer, Sheave, 7/8” Lg.	8
Glide Block Spacer	4
Front Sheave Cover	2
Rear Sheave Cover	2
Plastic Glide Block, Swivel (rear cross-member)	4
Plastic Insert	4
Shim, 20GA, for Slider Blocks	8
Glide (Slider Block, front cross-member)	8
Front Left Cable, 391” Lg.	1
Rear Left Cable, 155-1/2” Lg.	1
Rear Right Cable, 217-1/2” Lg.	1
Front Right Cable, 433” Lg.	1
Hose Guard	1
Air valve and Air Filter Assembly	1
Hydraulic Hose Assembly (16ft. lg.)	1
Power Unit	1
Duty Cycle Decal	1
Headed pin (approach ramp, wheel stop)	8
Wheel Stop Weldment	2
Approach Ramp Assembly	2
Rubber Wheel Chock	2
Polytube, 1/4" OD, Black	45ft
Polytube, 3/8” OD, Black	16.67ft
Installation & Operation Manual	1
Lift it Right Manual “ALI”	1
Lift it Right Safety Tips	1
“ALI” Standards	1
“ALI” Quick Reference Guide	1
HOFFMAN DECAL	1

## 6. INSTALLATION INSTRUCTIONS

**PLEASE TAKE THE TIME TO READ THESE INSTRUCTIONS COMPLETELY. A QUICK CHECK OF THE CONTENTS OF THE ACCESSORY BOX WOULD ALSO DECREASE THE INSTALLATION TIME.**

- Gather the tools and materials required for the installation.
- Select the location best suited for your lift.

**NOTE:** In determining lift area check for the following:

- Ease of driving a vehicle on and off the lift.
- Overhead obstructions, low ceiling height, overhead doors, overhead heaters etc. Minimum ceiling clearance must be 12 ft. Lower ceiling heights may interfere with servicing some vehicles
- Floor obstructions, drains, uneven floor in lift area, work benches, electrical wiring in floor, etc.



**ATTENTION!** This lift is intended for indoor installation only. It is prohibited to install this product outdoors. Operating environment temperature range should be 41 – 104 °F (5 – 40 °C). Failure to adhere will result in decertification, loss of warranty, and possible damage to the equipment.

**IMPORTANT:** It is the user's responsibility to provide a satisfactory installation area for the lift. Lifts should only be installed on level concrete floors with a minimum thickness of six (6) inches or 150mm. Concrete must have a minimum compressive strength of 3000 psi (21 MPa) and should be aged thirty (30) days prior to installation. Please consult the architect, contractor or engineer if doubt exists as to the strength and feasibility of the floor to enable proper lift installation and operation.

It is the user's responsibility to provide all wiring for electrical hook-up prior to installation and to insure that the electrical installation conforms to local building codes. Where required, it is the user's responsibility to provide an electrical isolation switch located in close proximity to the lift that will enable emergency stop capability and isolate electrical power from the lift for any servicing requirements.

Recommended clearance around the lift is 3 to 4 feet. Ensure clearance conforms to local building and fire codes. Recommended overhead clearance is a minimum twelve (12) foot ceiling providing 6 feet for the maximum lift height and 6 feet for the supported vehicle. For vehicles taller than 6 feet it is recommended that the user provides additional overhead clearance or a shut off mechanism to stop the lift from raising the vehicle too high.

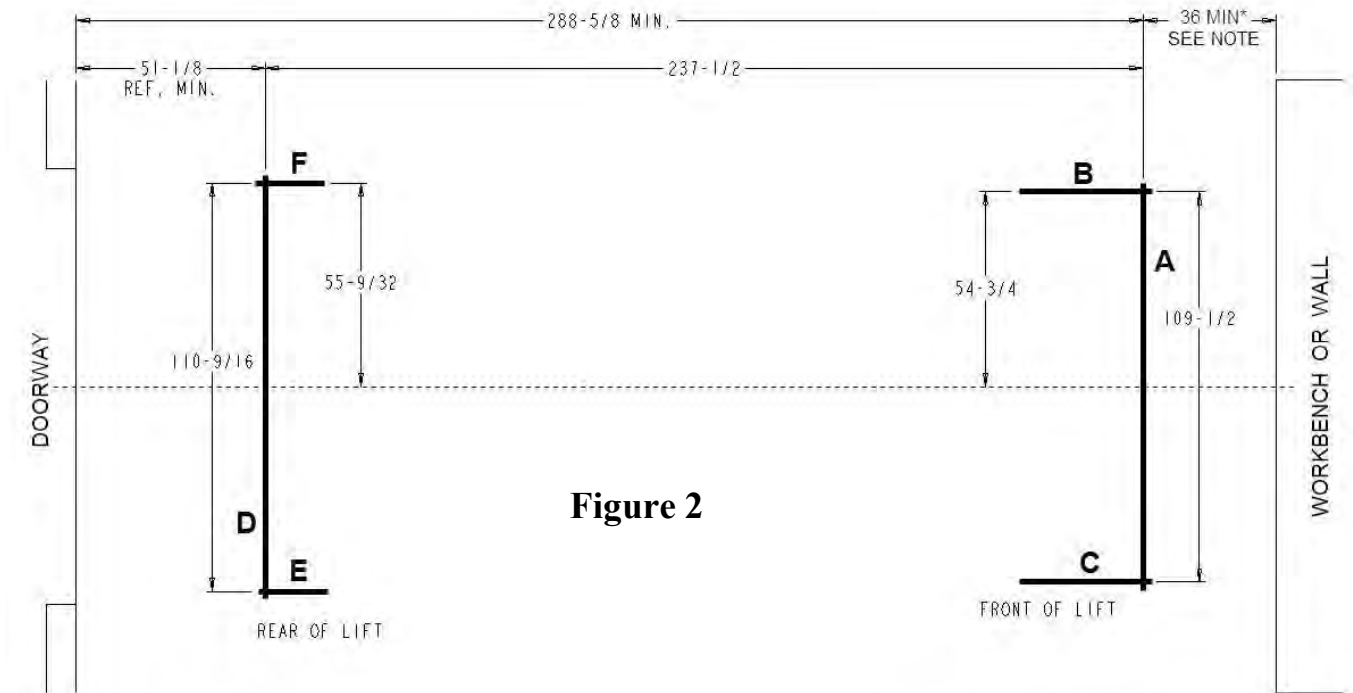
An outline matching the dimensions shown in **Figure 2** will need to be marked on the floor. Refer to Figure 2 for outline dimensions. Refer to General Lift Specifications for overall lift dimensions.



**WARNING** DO NOT install the lift on asphalt or other unstable surface. Lift columns are supported only by anchors in floor.

**INSTALLER:** PLEASE RETURN THIS BOOKLET TO LIFT OWNER/OPERATOR AFTER COMPLETING INSTALLATION

## 6.1 CHALK LINE LAYOUT



**Figure 2**

**NOTE:**

If using this lift in conjunction with an alignment system, consult aligner manual for manufacturer's minimum recommended distance to front turn table, and adjust this dimension accordingly.

**⚠ WARNING**

None of the front anchors shall be closer than 4-3/4" to any edge of a concrete slab, expansion joint or crack in the garage floor. Review position of front towers, base plates and anchors, and relocate lines "A", "B", "C" if needed.

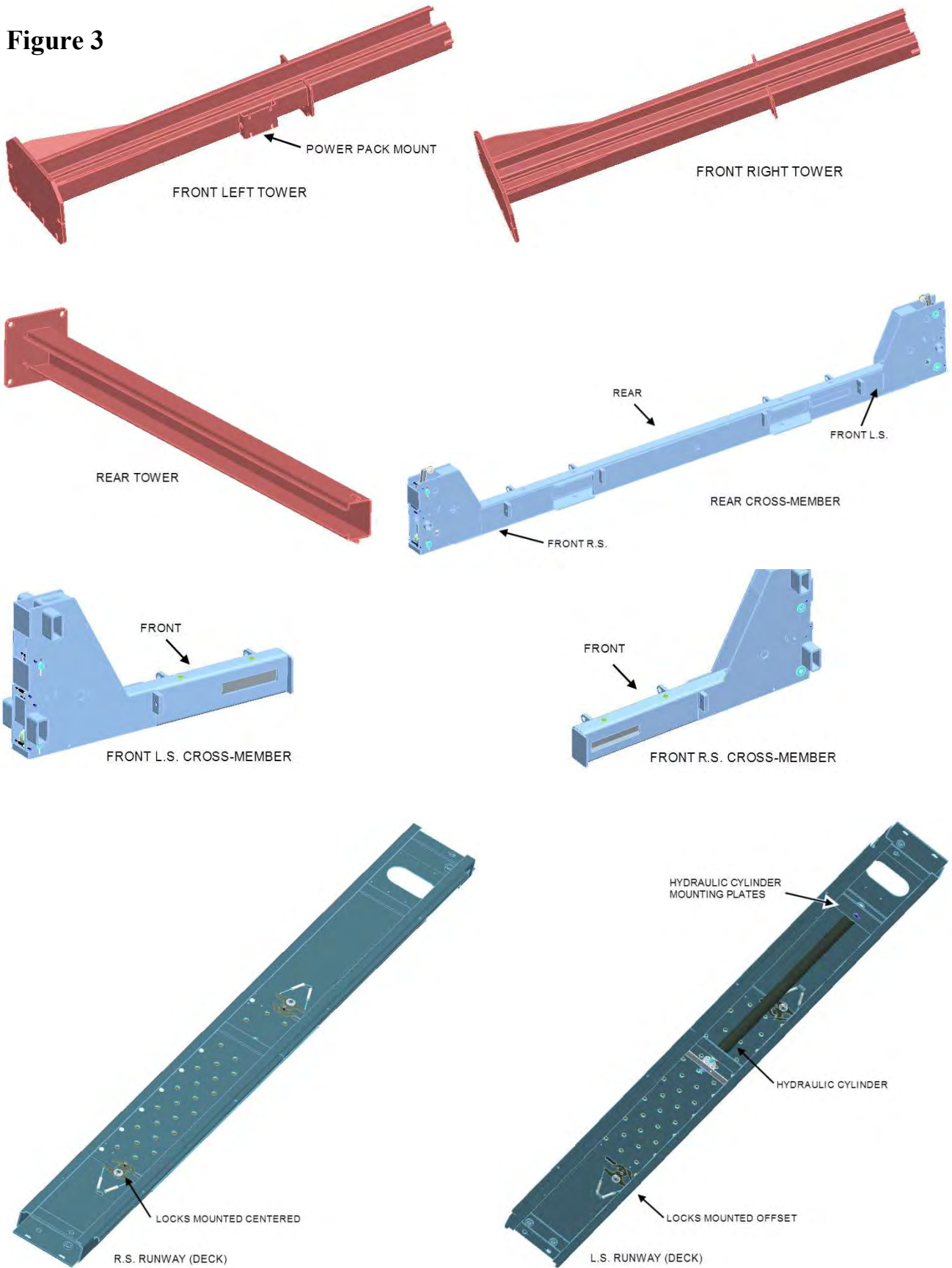
- **Refer to Figure 2.** Make a chalk line parallel to the doorway at least 288-5/8" from the doorway. This will be the location for the front edges of the front tower base plates. Call this line "A".
- Determine the center of the doorway and bay. Make a centerline to intersect with line "A".
- Make two chalk lines spaced 54-3/4" to the left and right side of the centerline (109-1/2" apart). Call these lines "B" and "C" respectively. These will be the locations of the inside edges of the front tower base plates.
- Make a chalk line spaced 237-1/2" to the back from line "A". Call this line "D". This is the position of the rear edges of the rear tower base plates.
- Make two chalk lines spaced 55-9/32" to the left and right side of the centerline (110-9/16" apart). Call these lines "E" and "F" respectively. These will be the locations of the inside edges of the rear tower base plates.

## 6.2 IDENTIFICATION OF MAIN LIFT COMPONENTS

- Identify and unpack major lift components (cables, columns, traverse beams) and place them where they belong (front left, front right etc.) See **Fig.3**.

- Place components in their approximate locations. Do not unwind cables at this point. Leave cables coiled, close to their respective towers.
- Place runways (decks) about 40" apart and about 3 ft behind line "A"

**Figure 3**



- Identify and place coiled cables as follows, close to their respective towers (Table 2):

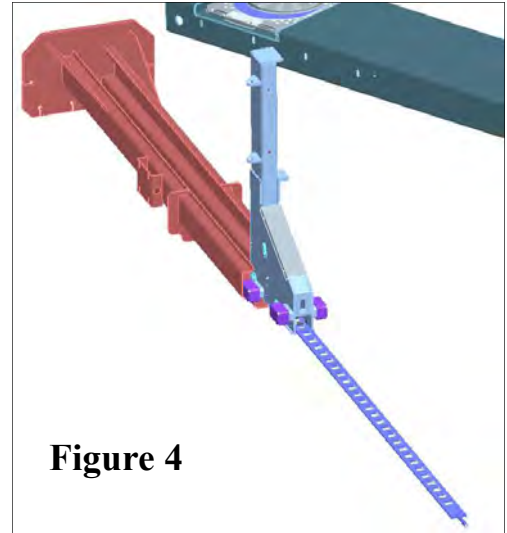
CABLE P/N	LOCATION	LENGTH
2-2914	FRONT LEFT	398-1/4"
2-2933	REAR LEFT	165-1/2"
2-2916	REAR RIGHT	224-3/4"
2-2917	FRONT RIGHT	450-1/4"

**Table 2: Cable part numbers**

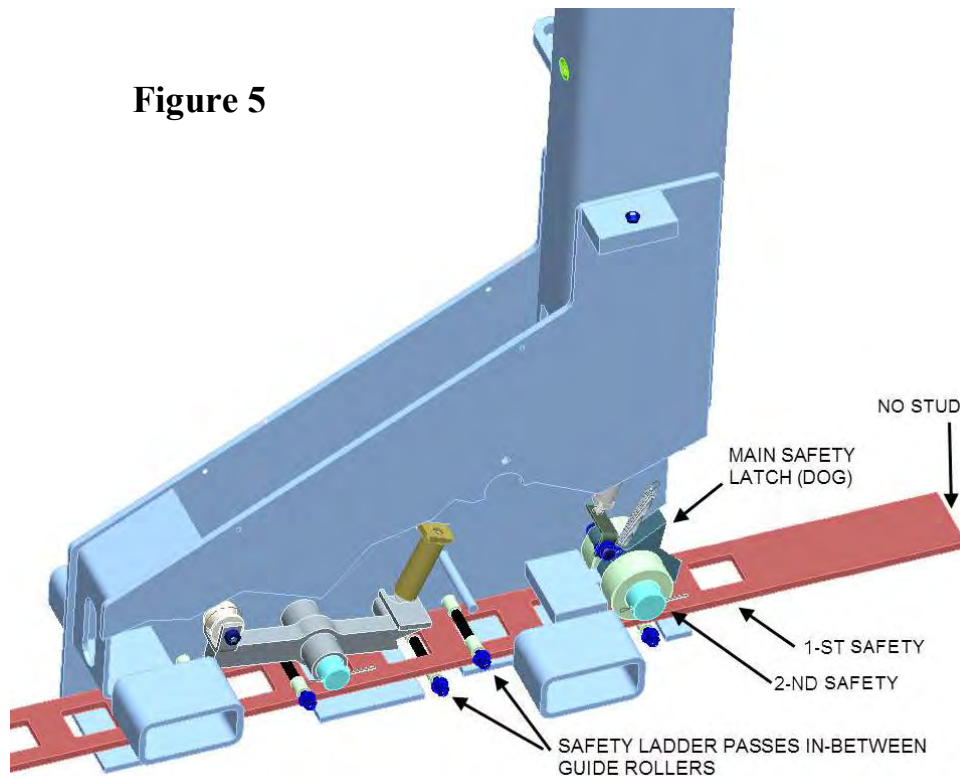
### 6.3 FRONT CROSS-MEMBERS AND TOWER ASSEMBLIES

- Lay front left tower on its back, with base plate close to its final position (see chalk lines) and top pointing to the rear of the lift and slightly to the left.
- Position left front cross-member to the end of front left tower, as shown in **Figure 4**.
- Insert safety plate (ladder) into front left cross-member, non-stud end first, as shown in **Fig.4** and **Fig.5** Insert safety ladder until main safety latch (dog) engages into 2<sup>nd</sup> safety cutout. See **Fig. 5**

**NOTE:** When installing the Safety Ladders, ensure they pass in-between the guide rollers as shown.

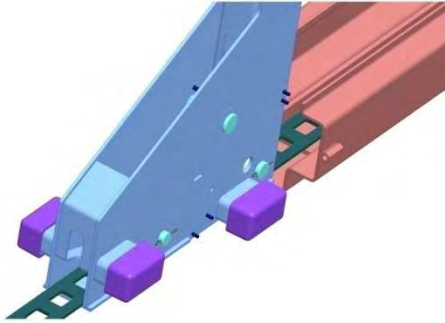


**Figure 4**



**Figure 5**

- Assemble slider blocks to front cross-member (See **Figure 6**)

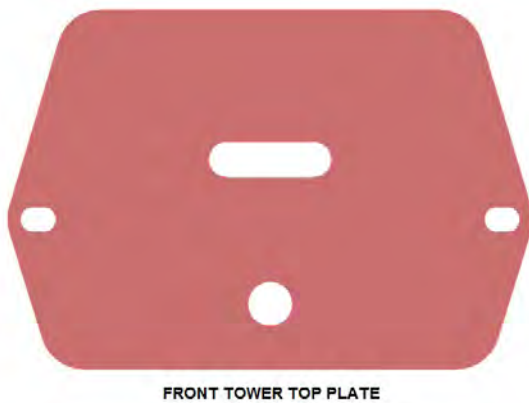


**Figure 6**

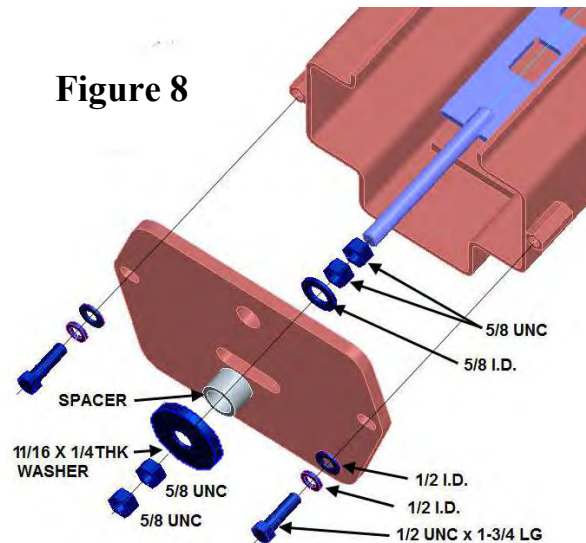
- Slide front cross-member (with safety ladder mounted) into front tower, until safety ladder has touched the tower base plate.
- Retrieve front tower top plate (**Figure 7**) in accessory box. Retrieve 2 flat washers (1/2" ID), 2 lock washers (1/2" ID), 2 HHCS (1/2 UNC x 1-3/4 LG), 2 SAE flat washers (3/4" ID), 4 hex nuts (5/8 UNC) and 1 spacer from the hardware kit.
- Assemble top plate to front tower and safety ladder to top plate as shown (**Figure 8**)

**NOTE:**

**Spacer is intended to allow the safety ladder to float, after assembled the top plate, ensure the ladder is free to move in the slot.**



**Figure 7**



**Figure 8**

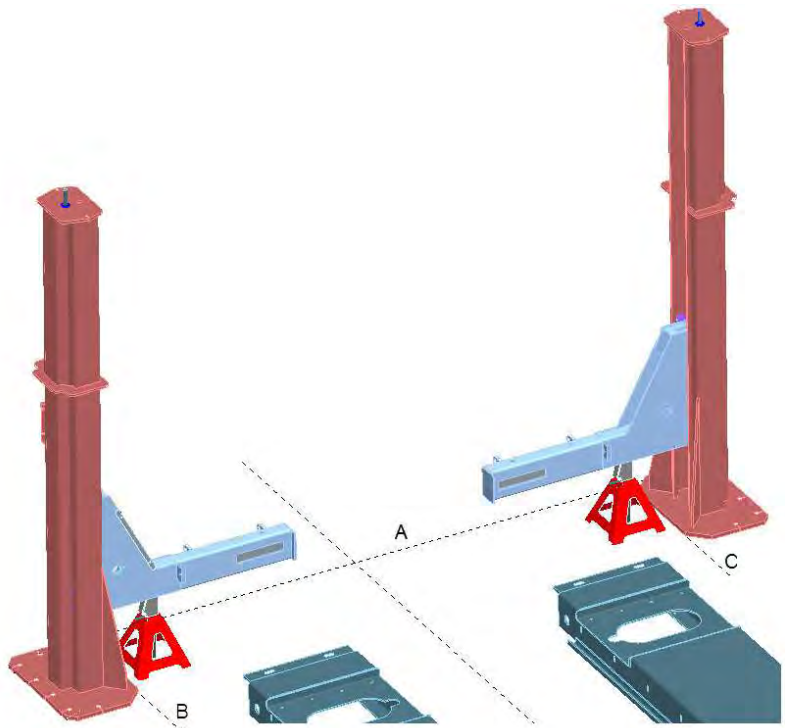
- Stand up tower, move into position at the front of the lift (see Fig.10), and line up with lines “A” and “B”. **Handle tower and front cross-member only by the tower.** As the cross-member is only restrained to the tower by safety locks, care must be taken when handling tower with cross-member.



None of the front anchor holes shall be closer than 4-3/4" to any edge of a concrete slab, expansion joint or crack in the garage floor. If this situation occurs, relocate chalk layout before continuing installation

- Support front cross-member with a jack stand as shown (Fig.10). Stand should be placed close to tower.
- Repeat above steps for front right tower and right front cross-member. Align to lines “A” and “C” (See Figure 9)

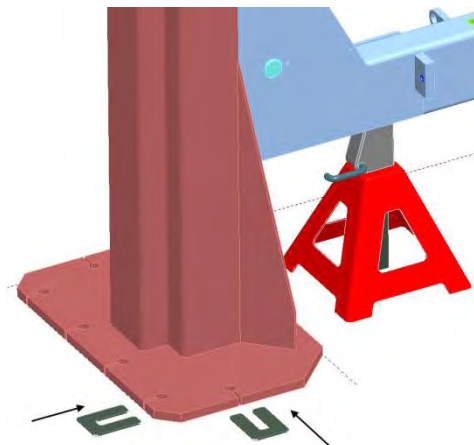
**Figure 9**



- Use a 4' level, to level the posts vertically (shim if necessary) as shown in **Figure 10** and **Figure 11**.



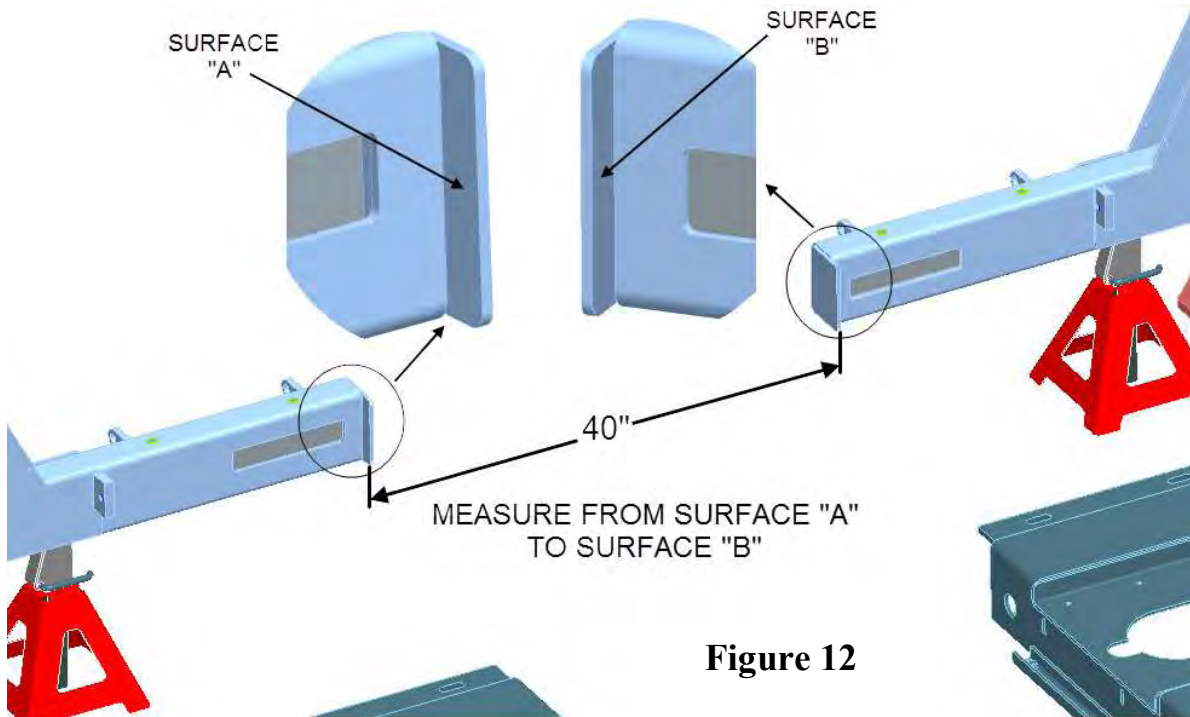
**Figure 10**



**Figure 11**

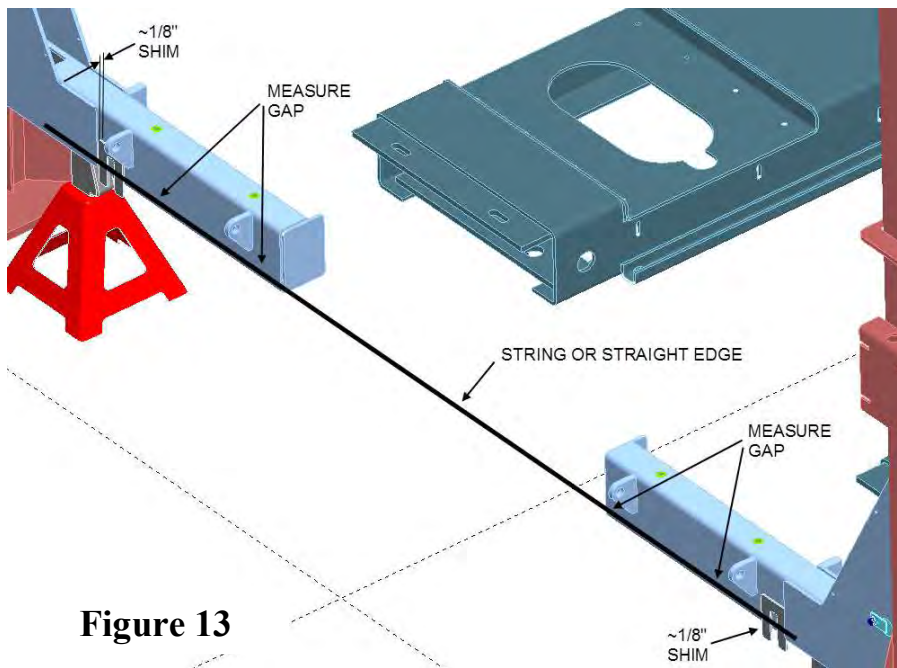
**⚠ WARNING** IF THE TOWERS ARE LEANING INTO THE LIFT, THE CROSS MEMBERS CAN BECOME WEDGED INTO THE TOWERS AS THE LIFT RAISES.

- Level columns so that they are plumb to each other, making sure the distance between deck contact surfaces of the runway stoppers (surfaces “A” and “B”) is 40” (**Fig.12**).



**Figure 12**

- Use a straight edge (string line) along front side of beams along with 1/8” column shim provided and ensure equal spacing throughout entire area of both beams (**Fig.13**). Rotate the columns if required to make cross-members parallel.

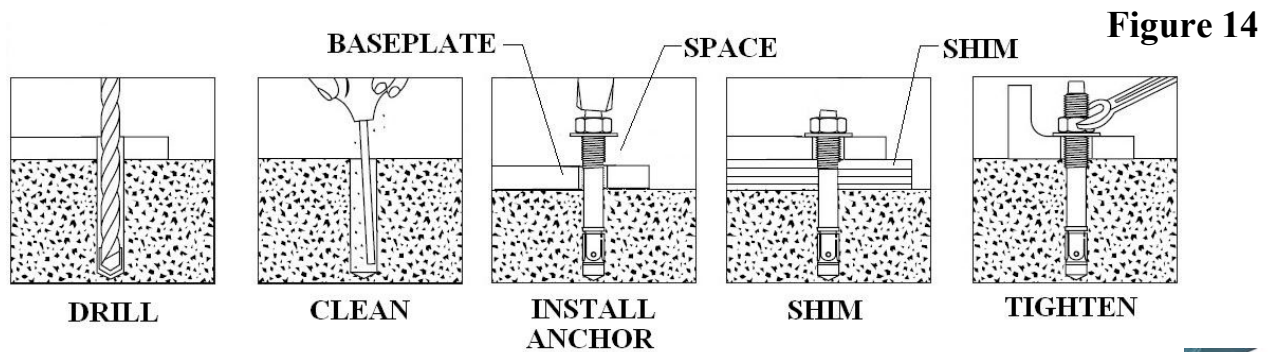


**Figure 13**

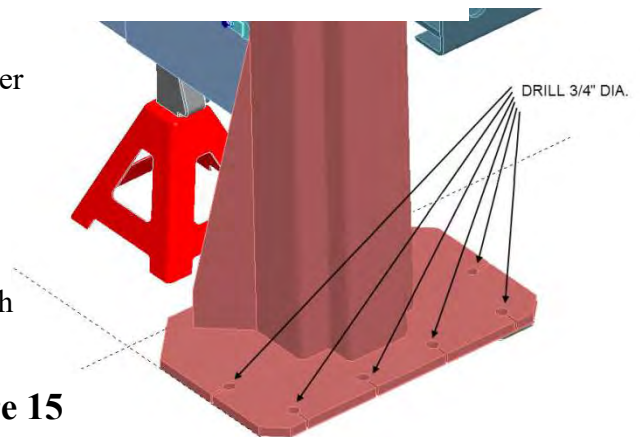


## 6.4 ANCHOR FRONT TOWERS

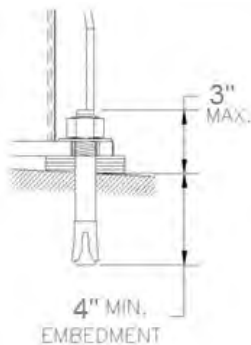
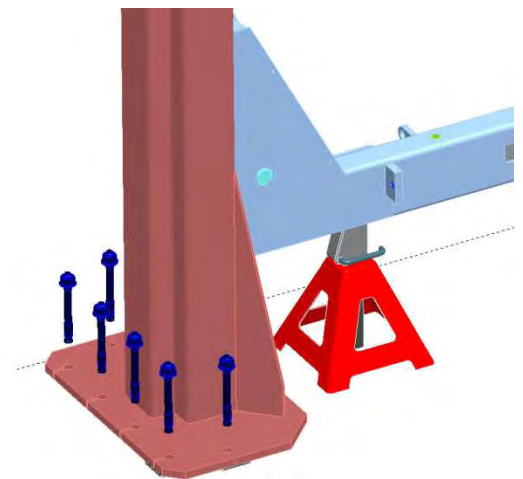
- Prior to installing anchors, assemble the nut and washer onto anchors. A minimum of six threads must be visible below the surface of the nut. Refer to the **Figure 14** while reading through the following instructions.



- If shop floor is not level, determine which front tower sits on higher floor
- Using a 3/4" concrete drill bit and rotary hammer drill, drill 3/4" holes for the anchor bolts on the high side column. Drill completely through the concrete floor (**Fig.15**). In case longer anchors are required, supplied anchors can be hammered through concrete.



- Clean out the drilling dust from the holes and hammer in the anchor bolts until they make contact with the base plate. Hand-tighten all anchor bolts.
- Check that the column is level front to rear and side to side. Adjust shims as required.
- If excessive shimming (greater than 5/16") is required, grout or additional support is required under the towers.
- Torque all anchor bolts to 110 ft-lbs. (150 Nm), continually checking that the column is level as you proceed.



**NOTE:** The 3/4" × 7" lg. wedge anchor bolts supplied must have a minimum embedment of 4" into the concrete floor.

**NOTE:** If anchors do not tighten to required torque, OR project more than 3” above the concrete surface, the concrete under the towers may not be sufficient and need to be replaced by an appropriate concrete pad.

**NOTE:** In cases where the floor is extremely out of level, the mechanical safety latches may not engage on the same lock

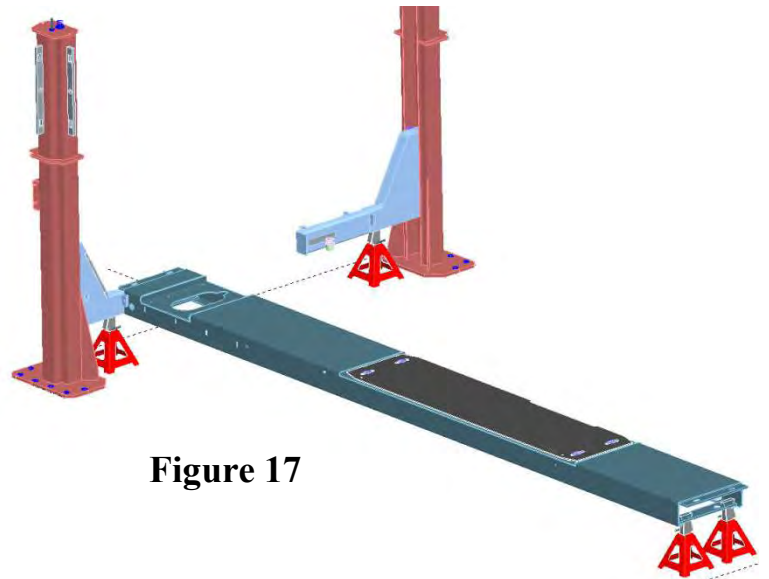
**⚠ WARNING** DO NOT use more than 1/2” (13mm) of shims. Anchor bolts supplied allow for a maximum of 1/2” (13mm) of shim. If more than 1/2” (13mm) of shims are required, DO NOT proceed with installation and contact Snap-on Equipment Technical Support for further details.

**NOTE:** Refer to Fig.1 and Fig.2 to ensure that the column is still in the proper position.

- Repeat procedure for the other front tower.

## 6.5 DECK ASSEMBLIES (FRONT)

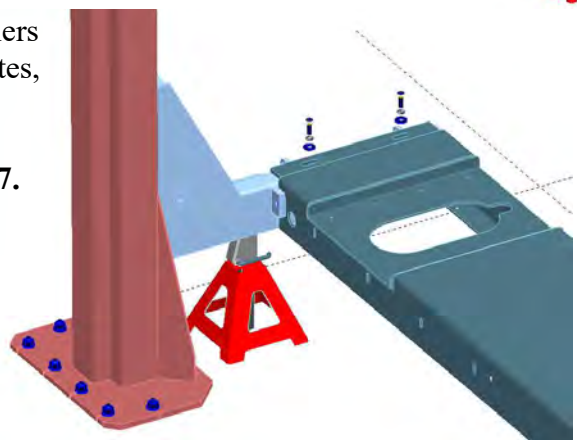
- Raise left side deck and place the front end plate of deck on top of front cross-member. Ensure the mounting slots in deck end plate line up with (threaded) mounting holes in cross-member. Support rear end on a jack stands (Fig.17).



**Figure 17**

- Insert 1/2”-13 HHCS x 1-1/2” long bolts, 1/2” washers and 1/2” lock washers thru slots in the front end plates, into cross-member tube (see Fig.18).

**Do not tighten bolts. This will be completed in 6.7.**

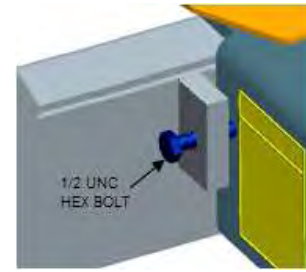


**Figure 18**

- Insert 1/2" UNC hex bolt in the jacking plates on cross-members (Fig.19). The 1/2" UNC hex bolts are found in the hardware kit.

**Do not tighten the bolt at this time.**

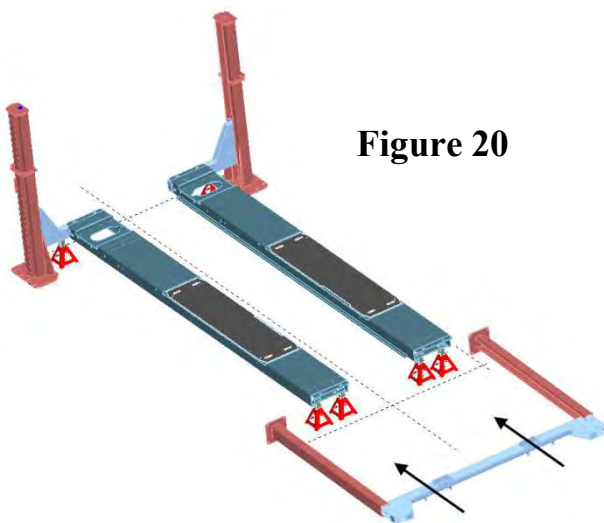
**Figure 19**



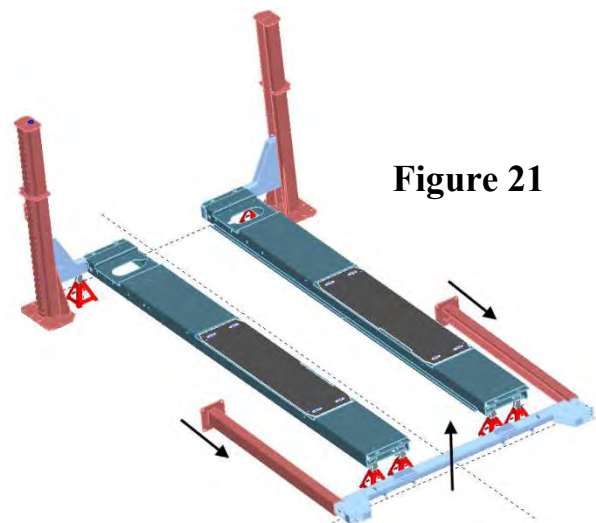
- Repeat procedure for the right side deck.

## 6.6 REAR CROSS-MEMBER AND TOWER ASSEMBLIES

- Remove rear cross-member from packaging and place it with cut-outs pointing up and the ends close to the rear towers tops, lying on the floor.
- Depending on the space available on the shop floor, rear towers and cross-members will be laid out in one of the 2 following situations:

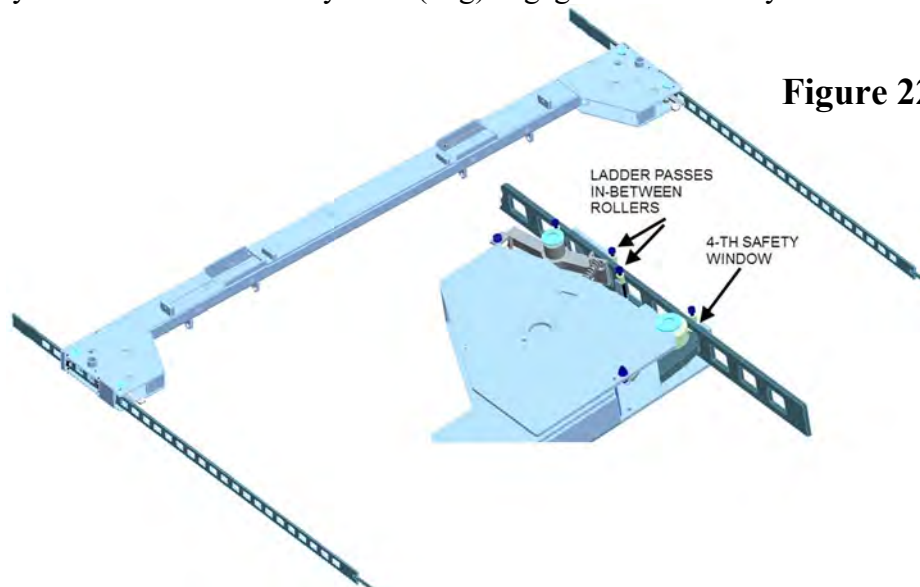


**Figure 20**



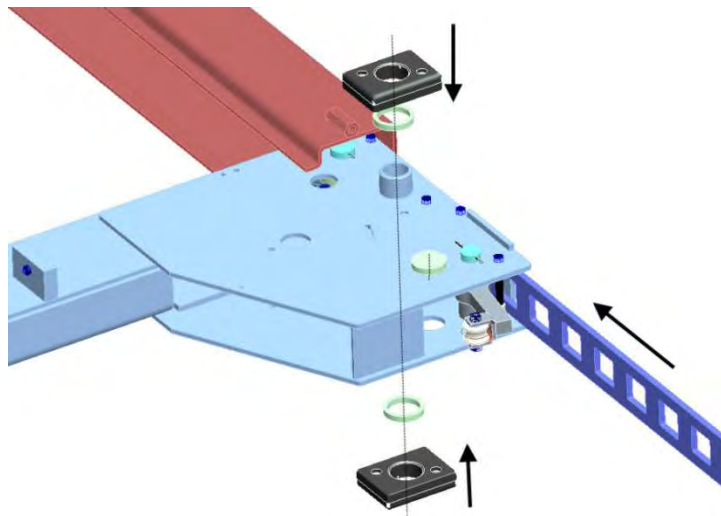
**Figure 21**

- Insert safety plates (ladders) into rear cross-member, non-stud end first, as shown in Fig.22. Insert safety ladder until main safety latch (dog) engages into 4<sup>th</sup> safety cutout. See Fig.22.



**Figure 22**

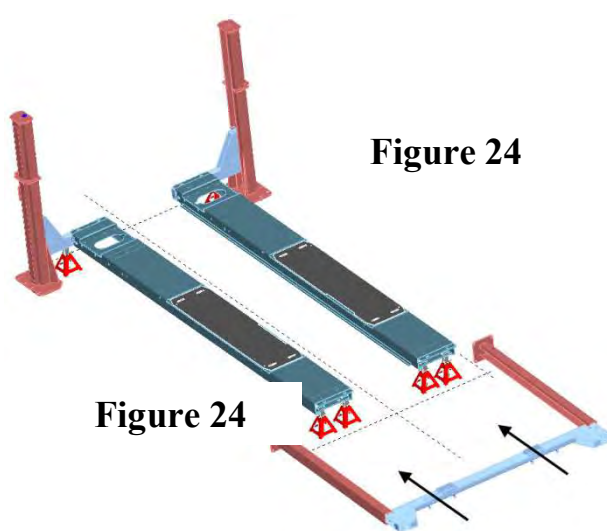
- Assemble sliders into the rear cross-member (**Fig.23**).



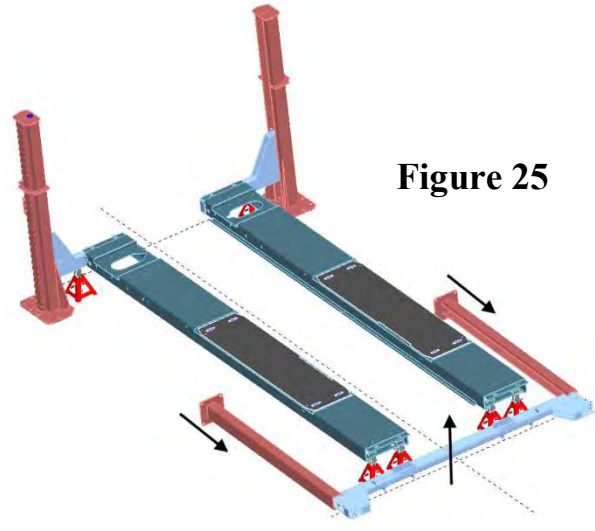
NOTE:  
Bevelled edges to be placed  
away from the traverse beam.

**Figure 23**

- Depending on the layout chosen for rear towers and cross-member, insert the cross-member in one of two ways:
  - Keep towers fixed on the floor and push rear cross-member toward the lift (**Fig.24**).
  - Push towers toward the back and gradually lift cross-member (**Fig.25**).



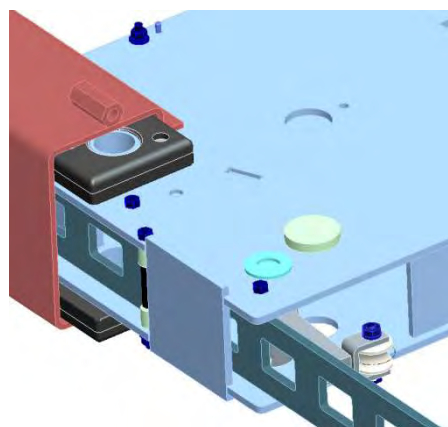
**Figure 24**



**Figure 25**

**Figure 24**

- Slide rear cross-member (with safety ladders mounted in) into rear towers, until safety ladder touches the base plate (**Fig.26**).
- Note orientation of slider blocks inside the rear tower (**Fig.26**).



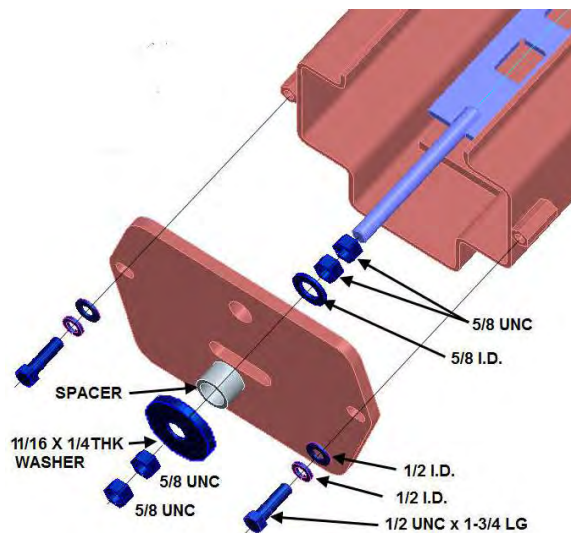
**Figure 26**

- Retrieve rear tower top plate in accessory box. Retrieve 2 flat washers (1/2" ID), 2 lock washers (1/2" ID), 2 HHCS (1/2 UNC x 1-3/4 LG), 1 SAE flat washers (5/8" ID), 4 hex nuts (5/8 UNC), 1 Ø11/16" x Ø2" x 1/4" THK washer and 1 Ø5/8" x Ø3/4" x 19/32" LG spacer from the hardware kit.
- Assemble top plate to rear tower and safety ladder to top plate as shown (**Fig.27**)
- Repeat operation for second rear tower.

**NOTE:**

**Spacer is intended to allow the safety ladder to float, after assembled the top plate, ensure the ladder is free to move in the slot.**

**Note:** Front tower shown in illustration as assembly is the same.



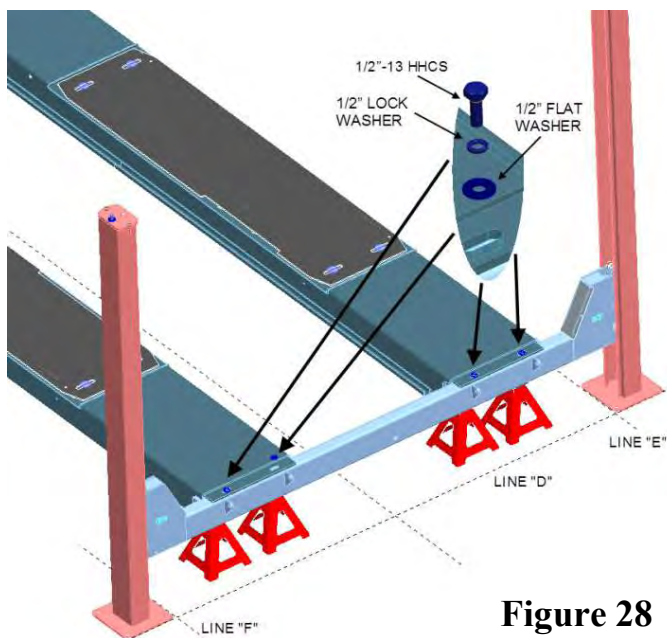
**Figure 27**



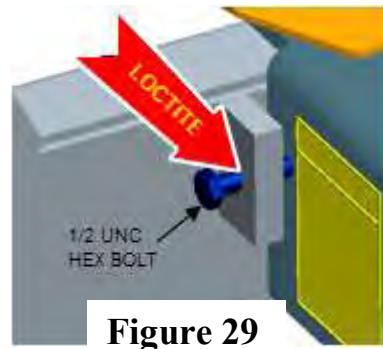
- Stand up towers, move into position at the back of the lift (see **Fig.2** and **Fig.28**), and line up with lines “E”, “F” and “D”. As the cross-member is only restrained to the tower by safety locks, care must be taken when handling towers with cross-member.
- Support rear cross-member with a jack stand as shown (**Fig.28**). Stand should be placed close to tower.
- If sub-assembly consisting of rear towers and rear cross-members is unstable, provide additional support for both towers

## 6.7 DECK ASSEMBLIES (REAR)

- Adjust height of decks or rear cross-member until end plates of decks rest on top of rear cross-member and the mounting slots in deck end plates line up with (threaded) mounting holes in rear cross-member. The rear cross-member should butt up against the deck.
- Insert 1/2"-13 HHCS x 1-1/2" long bolts, 1/2" washers and 1/2" lock washers thru slots in the front end plates, into cross-member tube (see **Fig.28**). **Do not tighten bolts.**

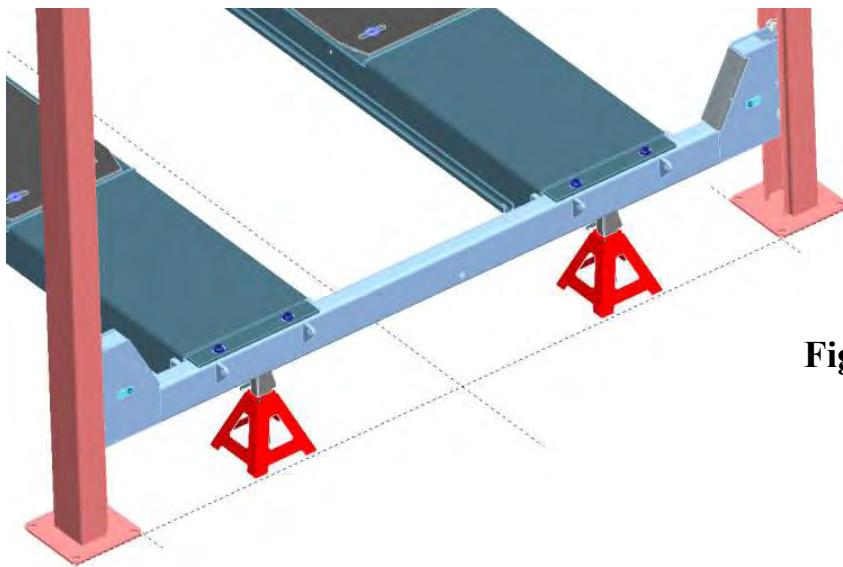


**Figure 28**



**Figure 29**

- Insert 1/2" UNC hex bolt in the jacking plates on cross-members (**Fig.29**). The 1/2" UNC hex bolts are found in the hardware kit.
- Back off the 4 bolts on the front and rear jacking plates, one at a time, Apply Loctite® on the bolt threads, then tighten (**Fig.19, Fig.29**) till the deck is flush against the stop on the opposite side. Do not over-tighten.
- Check all lift dimensions, and make adjustments if necessary. Tighten bolts mounting the decks to front and rear cross-members (see **Fig.18** and **Fig.28**).
- Transfer jack stands from under the decks to under rear cross-member (**Fig.30**).



**Figure 30**

## 6.8 CABLE INSTALLATION

REFER TO [Fig.46-a] FOR GENERAL CABLE ROUTING DIAGRAM.

### 6.8.1 Routing Front Left Cable

- Anchor threaded end of the front left cable into the top plate of the front left tower (**Fig.31**). Use one 7/8" ID flat washer and two 7/8-14 UNF hex nuts (see hardware kit).

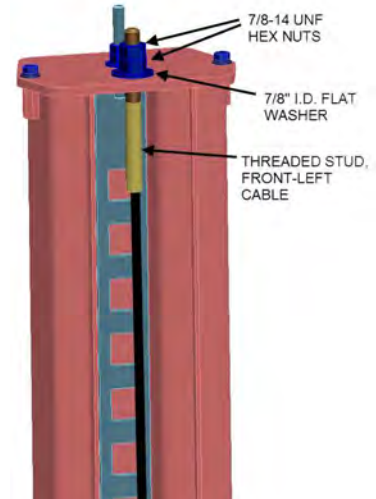


Figure 31

- Continue routing the cable, non-threaded sleeve first, through the slot in the top stiffener plate, through the front left cross-member (**Fig.32**). Pull sleeve end of the cable through the cross-member opening under the front of the left side runway (**Fig.33**)

**NOTE:** It is very important to route the cable inside a cross-member IN FRONT of the cable retainer shaft (see detail in **Fig.32**). Routing the cable behind the cable retainer shaft will not allow the cable to sit in the pulley groove and will cause damage to the lift.

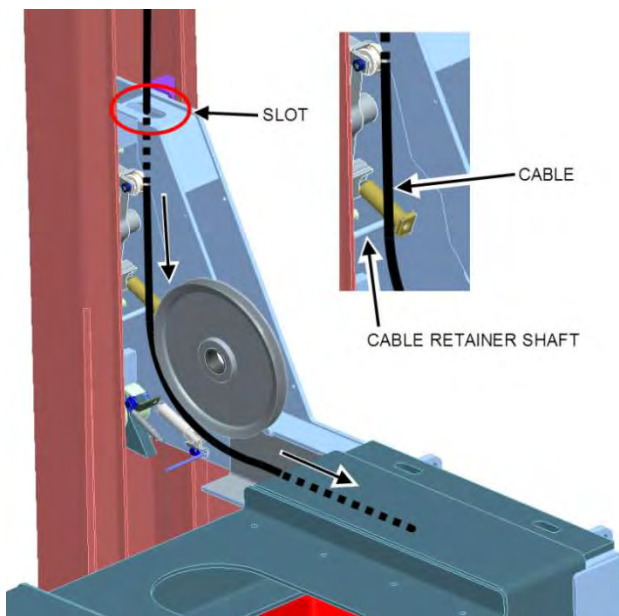


Figure 32

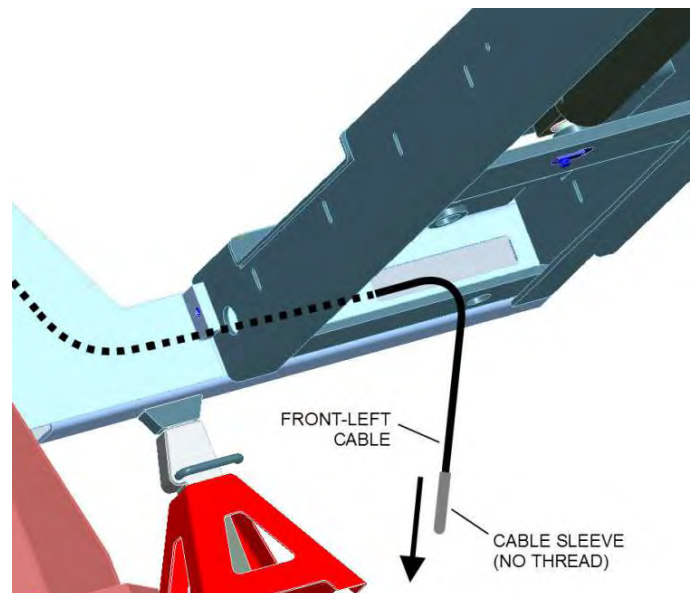
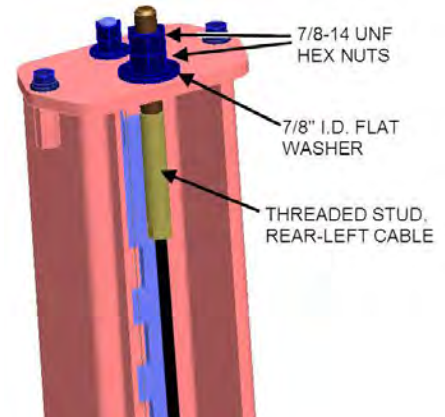


Figure 33

## 6.8.2 Routing Rear Left Cable

- Anchor threaded end of the rear left cable into the top plate of the rear left tower (**Fig.34**). Use one 7/8" ID flat washer and two 7/8-14 UNF hex nuts (see hardware kit).

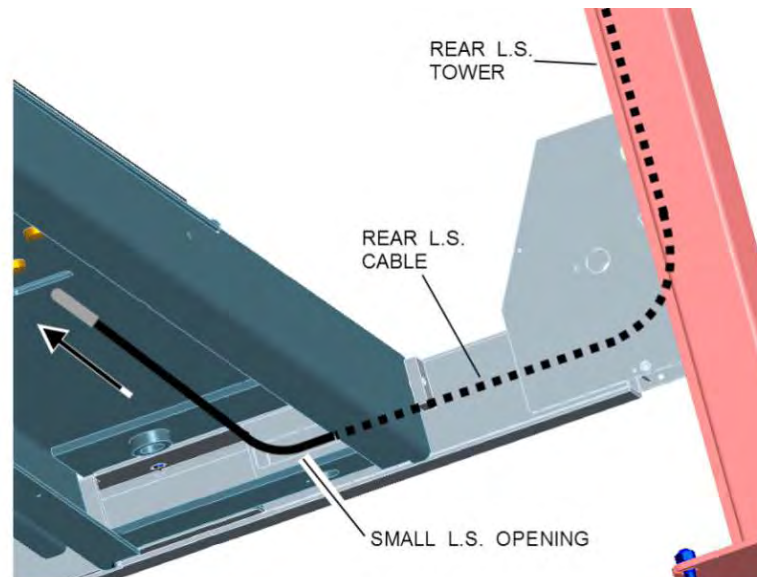


**Figure 34**

- Continue routing the cable, non-threaded sleeve first, through the rear cross-member. Pull sleeve end of the cable through the smaller opening under the rear of the left side runway (**Fig.35**).

**NOTE:** It is very important to route the cable inside a cross-member IN FRONT of the cable retainer shaft (see detail in **Fig.32**). Routing the cable behind the cable retainer shaft will not allow the cable to sit in the pulley groove and will cause damage to the lift.

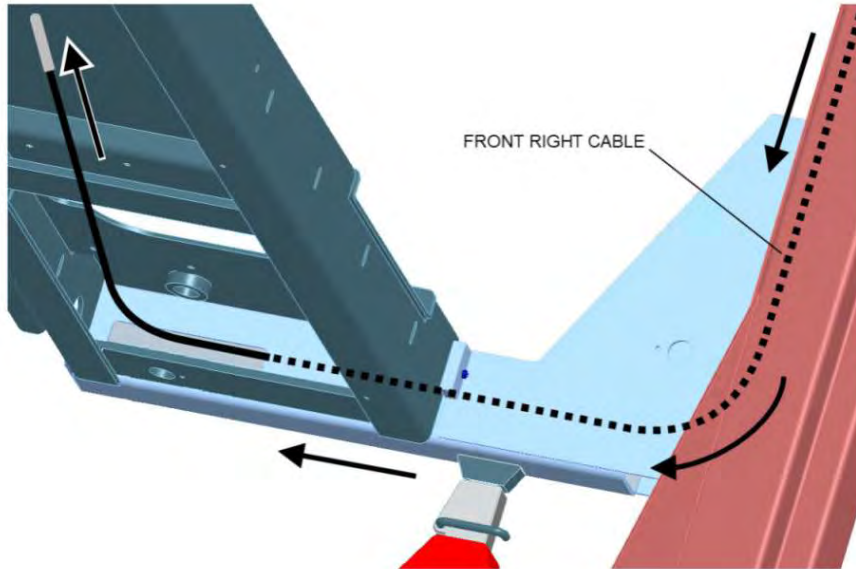
**Figure 35**





### 6.8.3 Routing Front Right Cable

- Anchor threaded end of the front right cable into the top plate of the front right tower. Use one 7/8" ID flat washer and two 7/8-14 UNF hex nuts (see hardware kit). Refer to **Fig.31**.
- Continue routing the cable, non-threaded sleeve first, through the slot in the top stiffener plate (Ref. **Fig.32**), through the front right cross-member. Pull sleeve end of the cable through the cross-member opening under the front of the right side runway (**Fig.36**).



**Figure 36**

- Continue routing the cable toward the rear of the right side runway (deck)

### 6.8.4 Routing Rear Right Cable

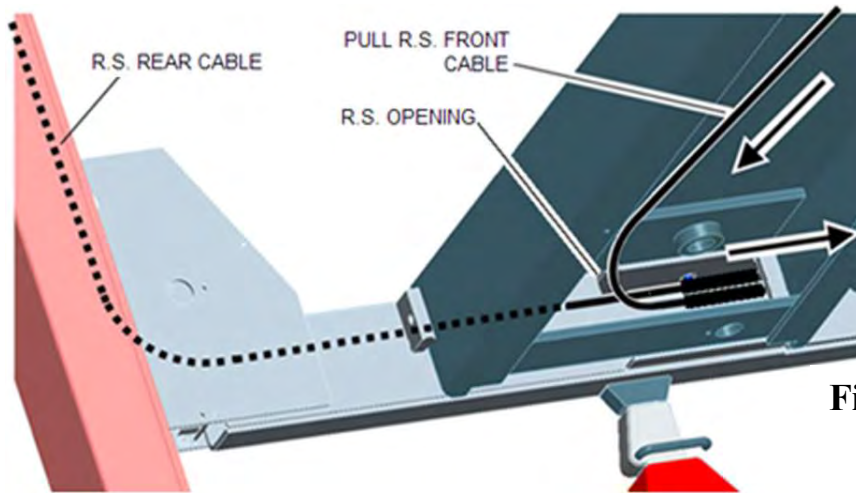
- Anchor threaded end of the rear right cable into the top plate of the rear right tower. Use one 7/8" ID flat washer and two 7/8-14 UNF hex nuts (see hardware kit). Refer to **Fig.35**.

**NOTE:** It is very important to route the cable inside a cross-member IN FRONT of the cable retainer shaft (see detail in **Fig.32**). Routing the cable behind the cable retainer shaft will not allow the cable to sit in the pulley groove and will cause important damage to the lift.

- Continue routing the cable, non-threaded sleeve first, through the rear cross-member, up to the right side opening.

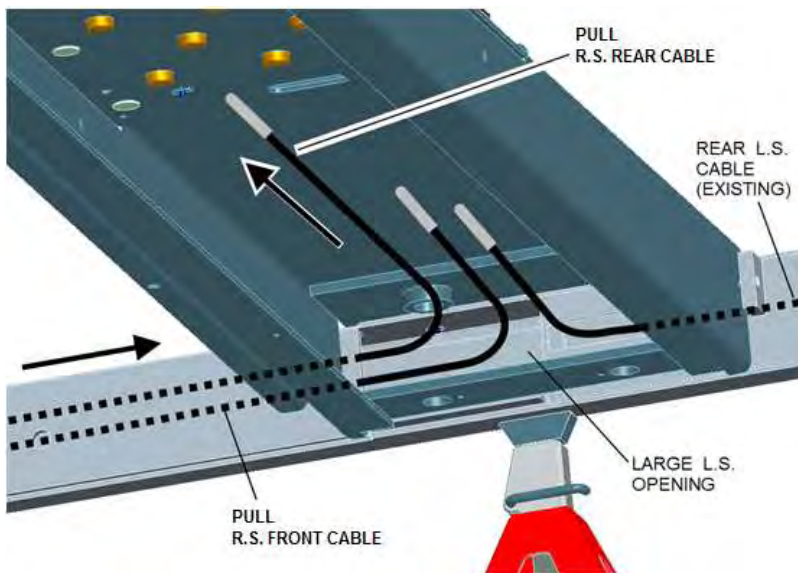
**NOTE:** Do not twist cables inside the tubes.

- On the right side, at the rear right opening (**Fig.37**), take the non-threaded plugs of the rear right cable and front right cable and tape them together with the RS rear cable on top, and feed both cables thru the window of the traverse beam.



**Figure 37**

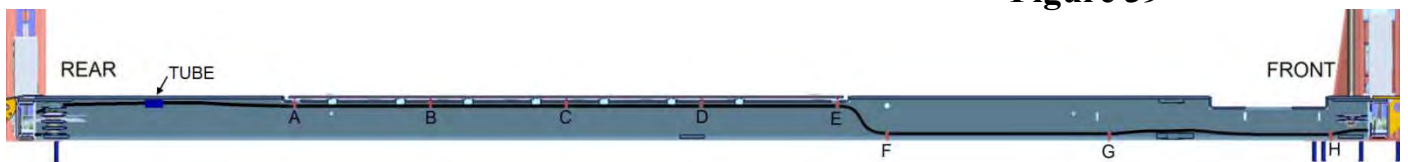
- Pull both cables out through the LARGE opening on the left side of the rear cross-member (Fig.38).



**Figure 38**

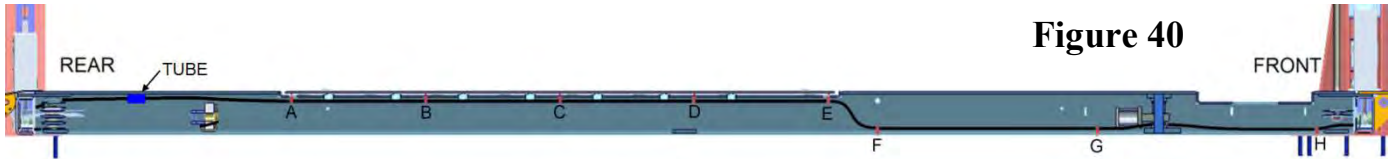
## 6.9 SAFETY RELEASE AIR LINES

- Install RS airline from the Tee fitting in front traverse beam to the fitting in rear traverse beam and zip tie in locations A, B, C,..., H identified below (Fig.39).



**Figure 39**

- Route LS air line from the tie "A" thru the TUBE and connect to the TEE fitting on the left side of rear cross-member. if necessary , reach with the hand thru window "W" in rear cross-member to hold TEE fitting while inserting air line.



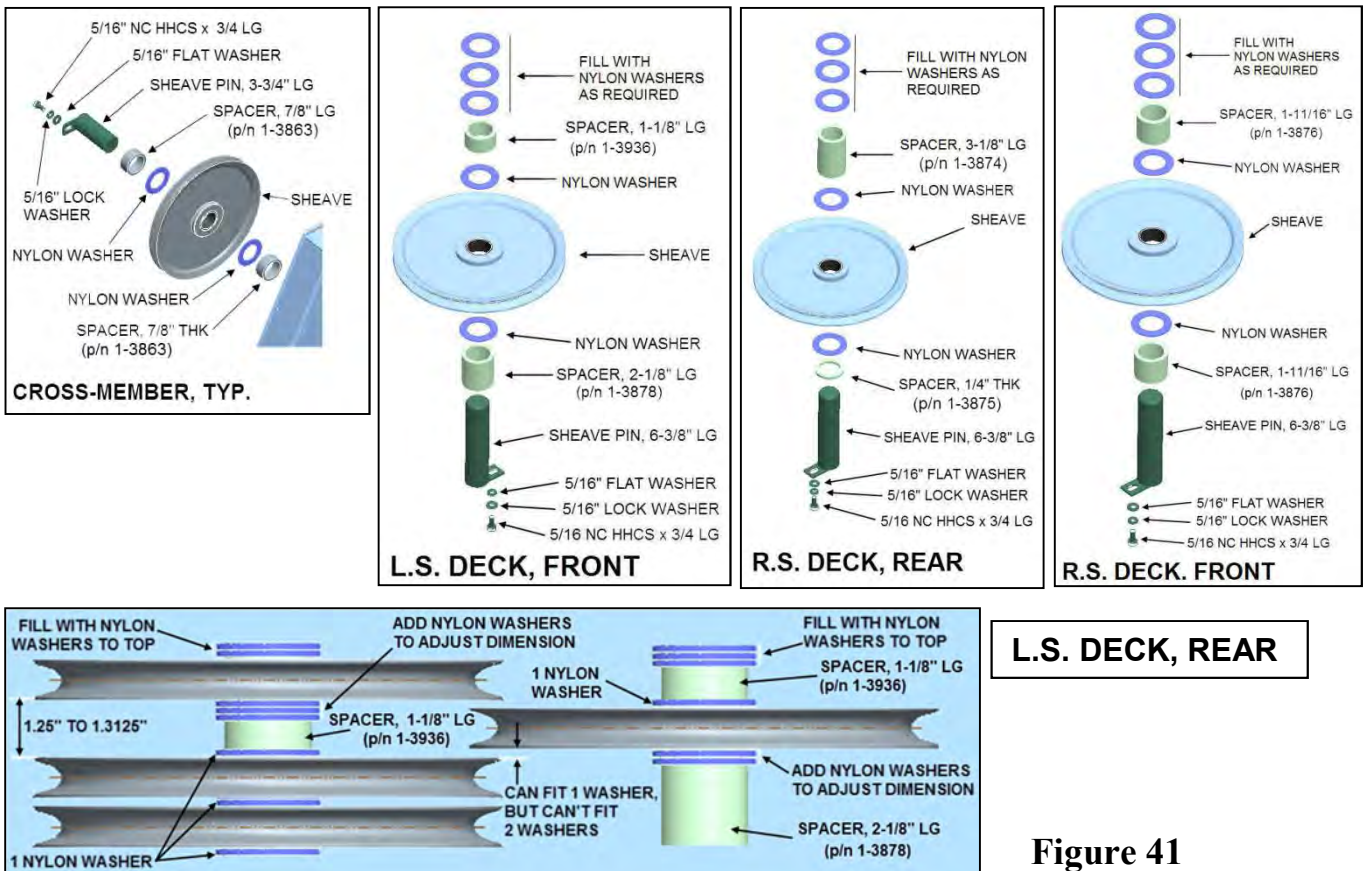
**Figure 40**

- Continue routing LS airline towards the front of the deck and zip tie in locations B, C, D and E. (**Fig.40**). At this point, leave the excess air line aside, and continue with installation. Do not install air line onto F, G, H, as this will be done after all the lines and hydraulic hose are installed, in **6.14**.

### 6.10 INSTALL SHEAVES. FINALIZE CABLE INSTALLATION

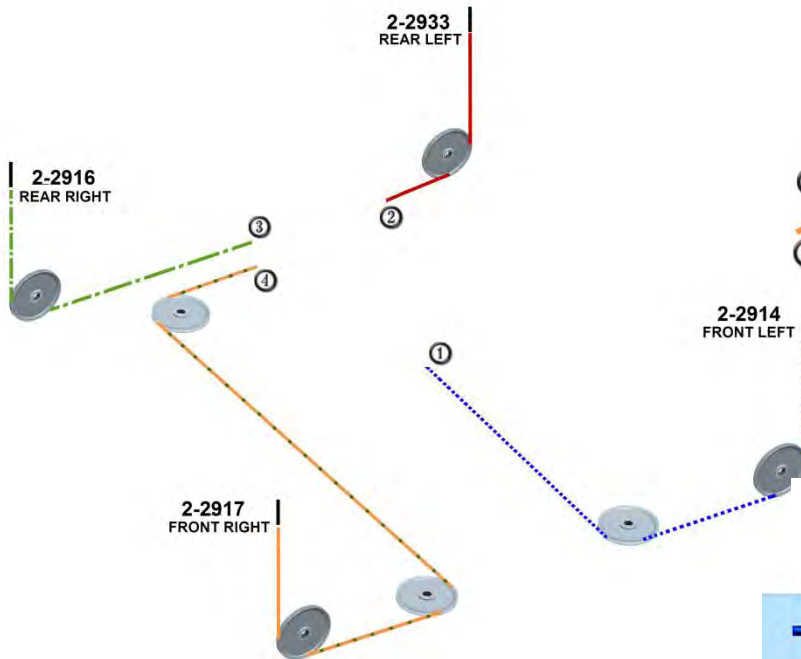
- Retrieve the deck sheaves, deck sheave pins ( $\text{Ø}1\text{-}1/2 \times 6\text{ }3/8$ " long), and deck sheave spacers from the accessory box. Retrieve the nylon thrust washers from the hardware kit. Please see following table for sheave spacer dimensions and location.
- See **Fig. 41** for position of sheave spacers.  
**Note:** Failure to install spacers and Nylon washers will result in premature cable or sheave failure and void warranty.

**Table 3: Spacers size and location**

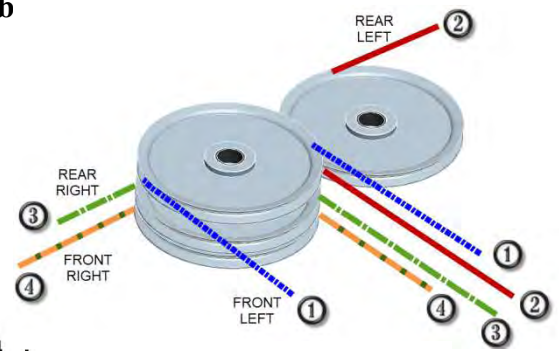


**Figure 41**

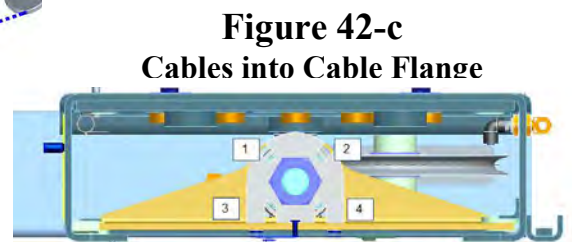
- Check that the cables are routed as in **Fig. 42-a** and **Fig. 42-b**



**Figure 42-a**  
Cable Routing

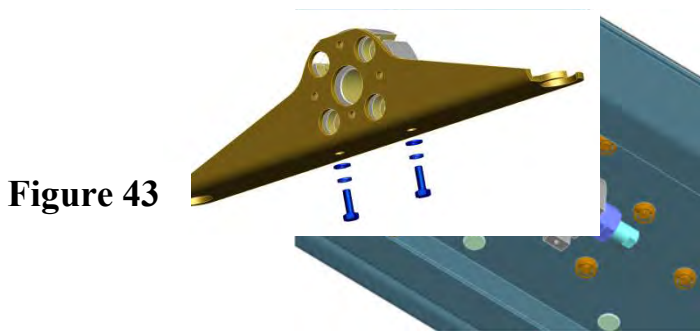


**Figure 42-b**  
Rear Pulleys Detail



**Figure 42-c**  
Cables into Cable Flange

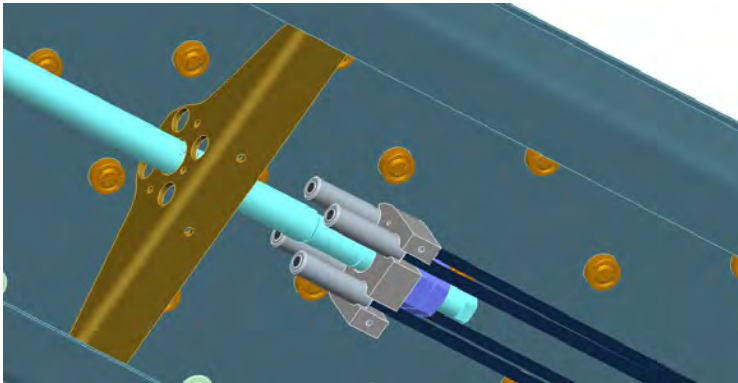
- Remove the two hex head bolts retaining the anti-rotation bar to the cable flange at the threaded end of the hydraulic cylinder (**Fig.43**). Carefully slide the anti-rotation bar towards the cylinder (**Fig.44**).



**Figure 44**

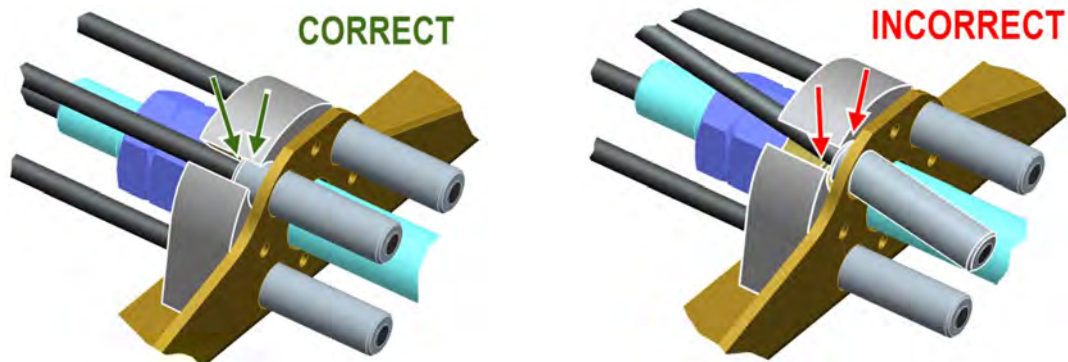
**NOTE:** THE CYLINDER ROD MUST BE FULLY EXTENDED IN ORDER TO ATTACH THE NON-THREADED ENDS (SLEEVES) OF THE CABLES TO THE CABLE FLANGE ON CYLINDER ROD. USE COMPRESSED AIR IN THE SHOP AND AN AIR NOZZLE AT THE BREATHER END TO EXTEND THE CYLINDER ROD. USE CAUTION AND PROTECTIVE EQUIPMENT WHEN WORKING WITH COMPRESSED AIR.

- Insert unthreaded studs of the cables into the cable flange as shown in **Fig. 45**.



**Figure 45**

- Unthreaded stud end of the cables must be installed to the cable flange in the positions noted in **Figure 42.c**.
- Ensure that the unthreaded stud ends are properly seated in the counter bores of the cable flange. Note the orientation of the anti-rotation bar with respect to cable flange and cylinder rod (**Fig. 46.a, Fig. 46.b**).



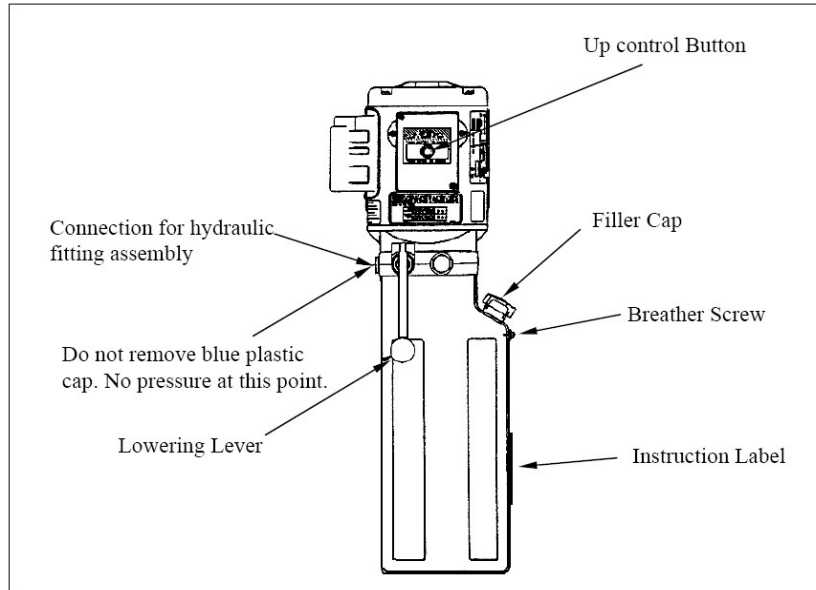
**Figure 46.a, b. Seating the cable in the cable flange slots**

- Once all cable have been routed, re-install the cable retainer and the 2 hex head bolts.

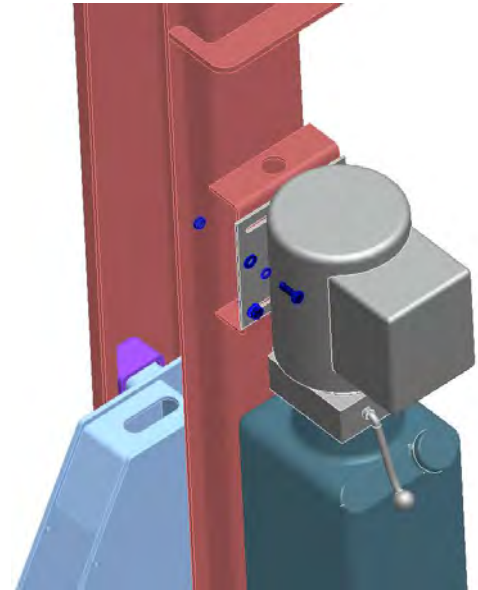
## 6.11 POWER PACK AND HYDRAULIC HOSE INSTALLATION

**NOTE:** WHEN WORKING WITH HYDRAULIC LINES AND VALVES, IT IS IMPORTANT TO KEEP ALL COMPONENTS CLEAN AND FREE OF DIRT.

### POWER PACK DETAILS



**Figure 47**

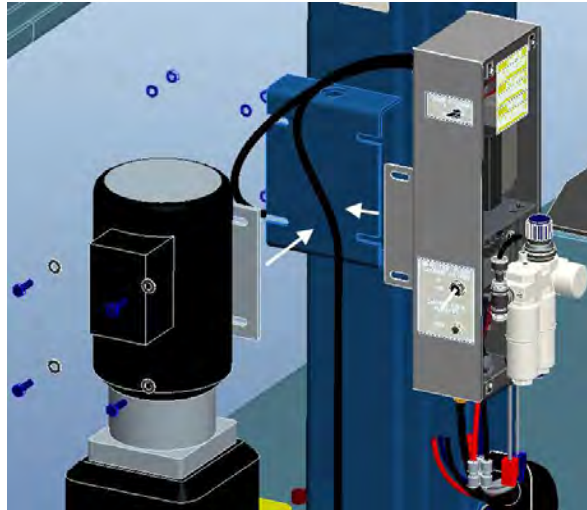


**Figure 48**

- Install the power pack to the mounting bracket on the front face of the left front post using the 5/16"-18UNC × 1"LG. hex head bolts and 5/16" washers, lock washers and hex nuts, found in the hardware kit (**Fig.48**).  
**Note:** Leave the (2) bolts towards the outer of the lift loose in order to install the Filter/Regulator/Lubricator assembly, see **Section 6.15**.
- Fill the reservoir on the power unit with 14 Liters of ISO 32 (10 Hydraulic Weight) hydraulic fluid.
- Retrieve the hose guard in the accessory box, and install in the opening on the left front side of the left side deck.
- Retrieve the hydraulic hose from the accessory box. Insert any end of the hydraulic hose through the hose guard, into the front end of the left side deck.
- Fasten one end to the hydraulic power pack and the other end to the flow control on the hydraulic cylinder.
- **Do not over-tighten hydraulic fittings**

## 6.12 MOUNTING LIGHTS & LOCKS CONTROL BOX (OPTIONAL)

1. Place the control box between the powerpack and mounting bracket. Use the 5/16" hardware found in the hardware kit to fasten items together.



**Figure 49**

2. On the inside of the front DS tower, mount the Roller Lever Light Sensor using the #8-32 screws #6-4135, internal lock washers #6-3465 and flat washers #6-3966. Ensure the lever is as shown in the below figure with roller towards tower (**Fig. 50a**).
3. Adjust the Roller Lever arm by loosening the center screw and rotating it downwards until you hear a clicking sound. Slide the arm towards the crossmember until the roller makes contact with the side of the front crossmember. Tighten screw.
4. Use (2) hose clamps #6-0170 and (2) screws #6-1353 to secure the sensor cable to the tower. (**Fig. 50b**).

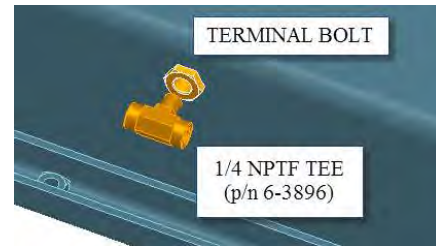


**Figure 50a & 50b**

5. Follow the electrical schematic to connect the control box to the powerpack.

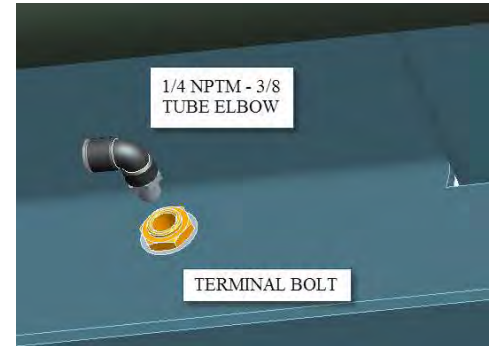
### 6.13 JACKING BEAM AIR LINE

- Install 3/4" terminal bolt and 1/4" NPTF Tee fitting on the outside of the deck, into the terminal bolt, as shown in **Fig.51**. At the end of installation, ensure that the branches of the Tee are approximately horizontal



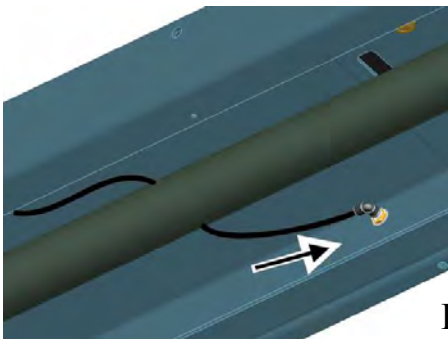
**Figure 51**

- Install the 90° elbow 1/4" NPTM to 3/8" tube push-in on the inside of the deck, into the terminal bolt, as shown in **Fig.52**.

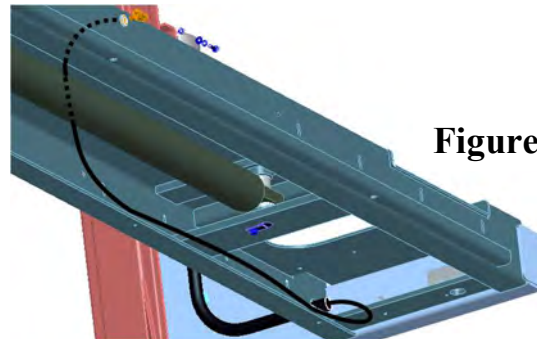


**Figure 52**

- Retrieve the (200 in long) 3/8 in dia. air line from the accessory box.
- Connect 3/8" tube to the push-in elbow, as shown in **Fig.53**.
- Run 3/8 dia. air line over the hydraulic cylinder, along left lip of the deck, and thru the hose guard (**Fig.54**).



**Figure 53**

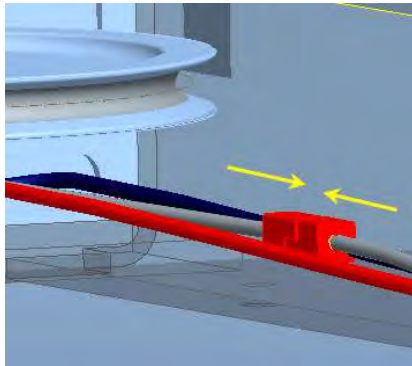


**Figure 54**

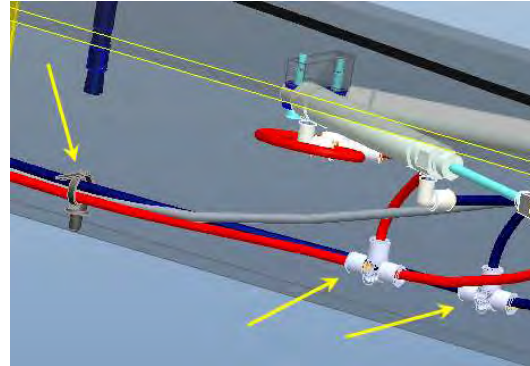


## 6.14 FRONT AND REAR LIGHT KIT CONNECTIONS (OPTIONAL)

1. Starting from the rear underside of the driver side deck assembly:
  - Connect the two red connectors that will send power to the lights on the right side deck assembly (**Fig. 55**).
  - From the rear crossmember, route the red and blue polytubes through the mounted zip tie on the deck, and then connect to the colour appropriate tee fitting. Tighten the tie wrap and cut excess (**Fig. 56**).

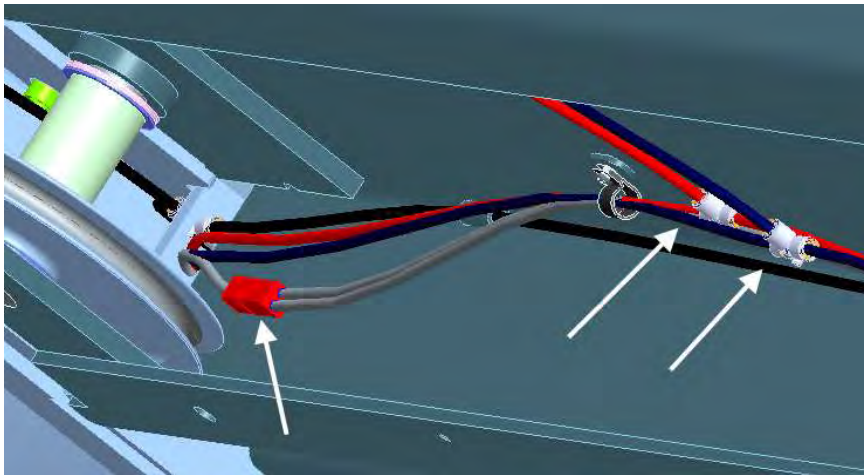


**Figure 55**



**Figure 56**

2. Next, continue onto the rear of the passenger side deck assembly (**Fig. 57**):
  - Connect the two red connectors for the light system.
  - From the rear crossmember, route the red and blue polytubes through the tube clamp on the deck, and connect to the colour appropriate tee fitting.



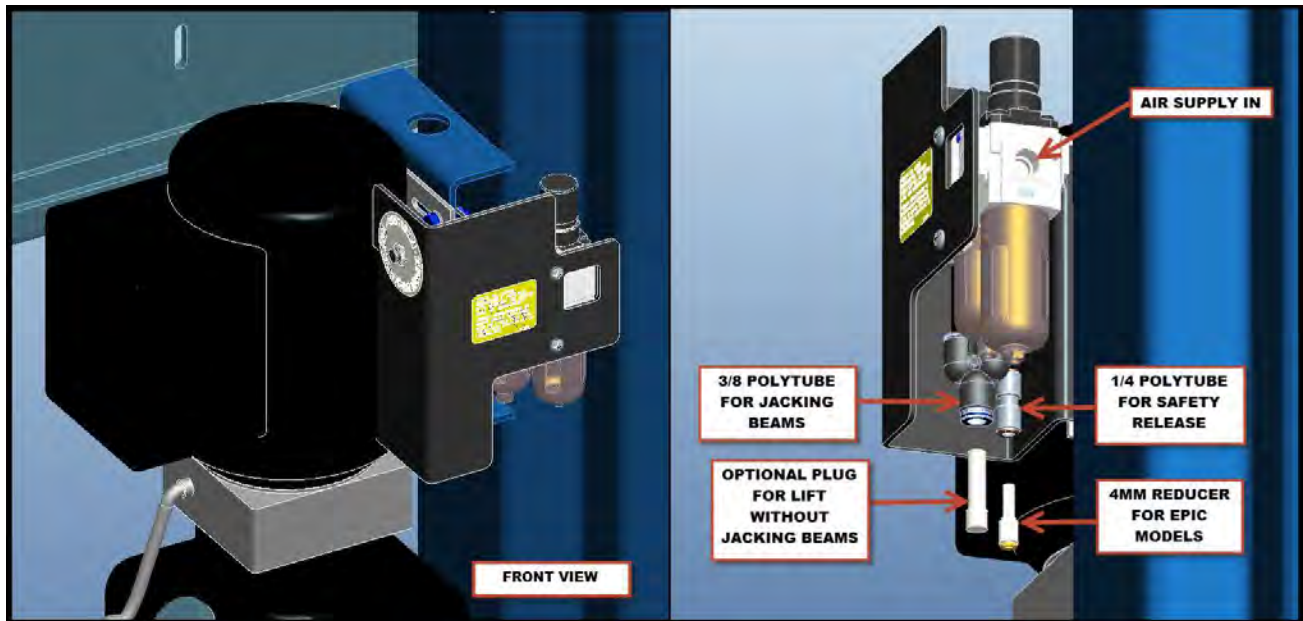
**Figure 57**

- Use a zip tie wrap to bundle all lines from the rear crossmember together.

## 6.15 FINALIZE AIR LINE INSTALLATION

NOTE: Please refer to the air and hydraulics parts list, page 70, **Fig.88**.

1. Continue LS safety release air line installation from point E (chapter 6.9, **Fig. 40**) to the front TEE fitting. Connect remaining 1/4 dia. air line to the front TEE fitting and pass free end thru the hose guard, out of the deck.
2. Zip tie hydraulic hose, jack beam air line and safety release air line together at the locations F, G and H (see **Fig.40**).



**Figure 58: FRL Assembly**

3. Install the air valve and filter assembly (found in the accessory box) to the mounting bracket on the power post.
4. To do this, slide the FRL assembly between the tower bracket and the 5/16" lockwasher.
5. Tighten up the hardware.
6. Connect the 1/4" polytube for the safety system and the 3/8" polytube for the jacking beams.

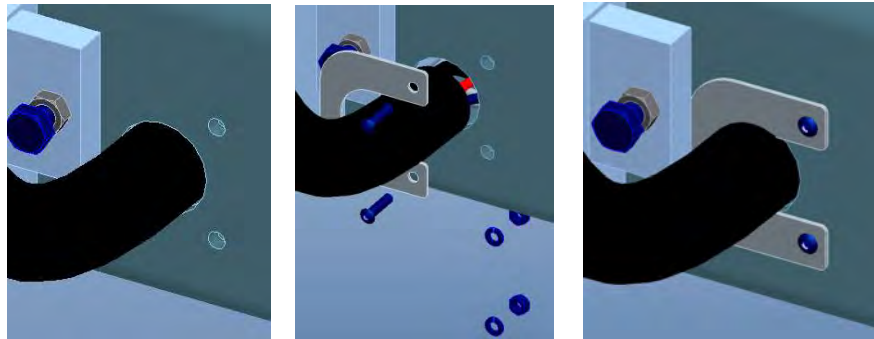
**NOTE: When cutting polytube, be sure to cut the line at 90 degrees. Failure to do so may result in leaks in the air connections.**

**NOTE: FOR THOSE UNITS EQUIPPED WITH JACKING BEAMS, THIS IS THE APPROPRIATE TIME TO INSTALL THEM. CONSULT THE JACKING BEAM INSTRUCTION MANUALS FOUND IN EACH JACKING BEAM BOX.**

7. Connect the air supply to the inlet on the FRL.

## 6.16 FINALIZE LIGHTS & LOCKS INSTALLATION (OPTIONAL)

1. From the front of the DS deck, there will be a total of (7) pneumatic, hydraulic and electrical lines that will be required to connect to the control box:
  1. RED Electrical Cable for RS Lights
  2. BLUE Electrical Cable for LS Lights
  3. RED 1/4" polytube for locking plates
  4. BLUE 1/4" polytube for locking plates
  5. BLACK 1/4" polytube for safety locks
  6. BLACK 3/8" polytube for JackBeams
  7. Hydraulic Hose Assembly to cylinder
2. From the access hole in the DS deck, route these lines through the corrugated hose protector. Insert approximate 1"-2" of the hose protector into the access hole on the deck.
3. Locate Hose Guard Clamp #1-4013 and slide it onto the hose guard between two of its ribs on the outside of the deck. Align the holes to the mounting holes on the deck and faster with 1/4" screws #6-3036, lock washer #6-0056 and nuts #6-0032.



**Figure 60**

4. At the control box, connect the pneumatic and electrical lines as shown in the below figure. Connect the hydraulic hose assembly to the powerpack.

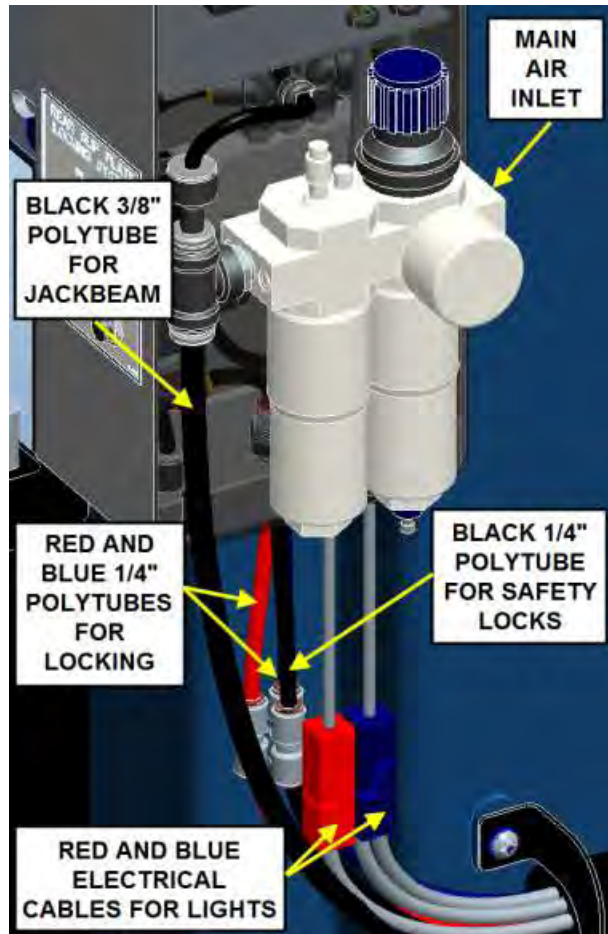


Figure 61

5. Locate Hose Guard Clamp #1-4014 and slide it onto the hose guard between two of its ribs approximately 1"-2" from the end. Align the holes to the mounting holes on the tower and fasten with 1/4" screws #6-1353 and lock washer #6-0056.

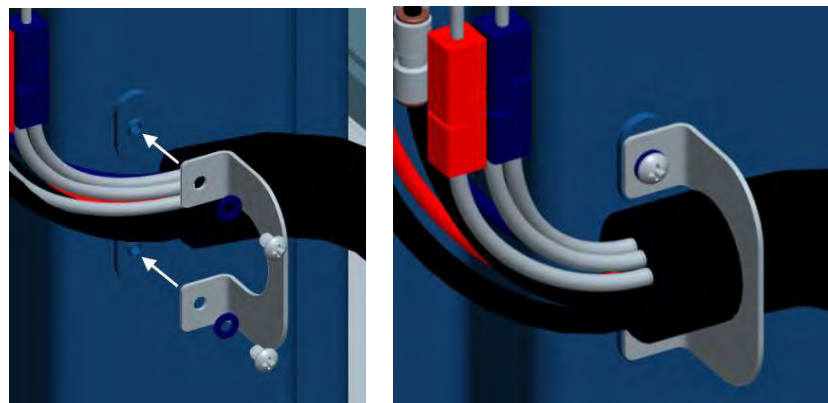


Figure 62

6. Connect the main air supply to the Filter/Regulator/Lubricator mounted to the outside of the control box (Fitting not included).

**NOTE:** Please refer to the Filter/Regulator/Lubricator commissioning procedure prior to operating lift, page 38.

7. Route the hydraulic line between the tower and tank of the powerpack and connect it to the 90deg fitting on the pump.

## 6.17 LOCKING FRONT TURNPLATES & REAR SLIP PLATES (OPTIONAL)

### Installation of Front Turnplates



Avoid inserting fingers in the front alignment pan cut-out, if position of the turnplate assembly exposes such openings.

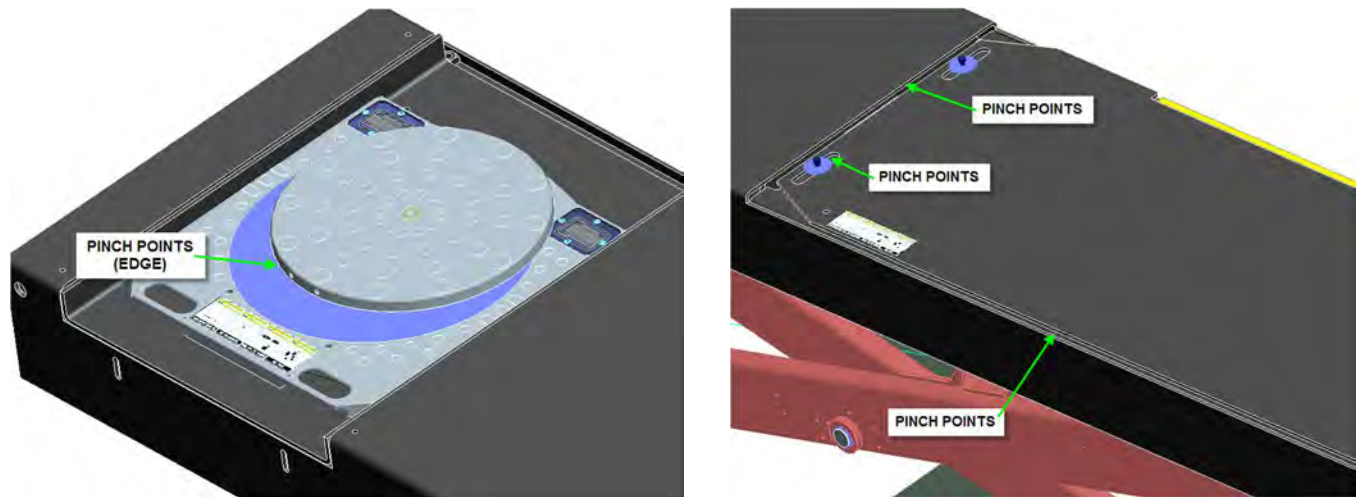


Ensure that air supply to the lift is turned off and no person is operating on the console during maintenance of clamping elements of the locking system.



During normal use, the front turnplates and rear slip plates may move rapidly, when locking system is activated. This creates pinch points for your fingers or hands. Keep hands clear of these pinch points when lift air supply is connected. No person shall operate console while maintenance or inspection of the slip plates is in process.

---



*\*Note: Objects in pictures may not be exactly as shown.*

**Figure 63a & 63b**

1. Lower lift to a comfort height.
2. Place each front turnplate assembly, one by one, on the front alignment pan on runway. Moving handles of the turnplates should be oriented to the outside of lift, shown below.

---

Ensure that the locking system components on the bottom of the turnplate (air cylinder, fittings, and plastic clamping parts) are not hitting against the runway during placement.

---

3. Verify that the turnplate assembly is completely seated in the front alignment pan. Gently slide each turnplate in the alignment pan, left and right, to verify that they can be positioned for different car widths. Do not hit plastic locking ring forcefully against the edges of the cut-out in the front alignment pan.
4. Connect free ends of front air lines to the turnplate locking cylinder: blue air line to the cylinder port marked with a blue dot and red air line to the cylinder port marked with a red dot [Figure shown below].

5. Plug the electrical connector on the turnplate light cord into the electrical connector on the cable at the front.

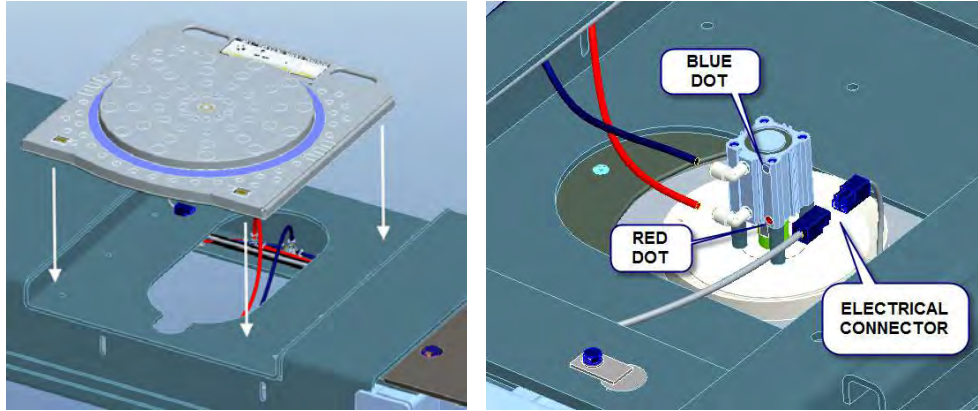


Figure 64a & 64b

## 6.18 FILTER/REGULATOR/LUBRICATOR COMMISSIONING (OPTIONAL)

### PROCEDURE FOR PREPARING FRL FOR USE WITH LIFT:

- 1) Disconnect shop air from FRL inlet. Adding Oil to the lubricator cannot take place under a pressurized condition.



- 2) Using a slotted screwdriver or an Allen key, remove the filler cap from the top of the FRL.



- 3) Fill FRL using Snap-On AirOil #IM6 or equivalent. Oil to be filled to the MAX line marked on reservoir. If unit does not have MAX line mark, reservoir should be 80% full.



- 4) Replace filler cap to top of FRL.
- 5) With the output end of the FRL disconnected (remove the quick disconnect fitting), reconnect the air line to the FRL unit. Air will flow freely through the FRL.
- 6) Perform Drip Check / Adjustment: Drips to be set to 2-3 per minute.

#### SMC Brand - DIAL VERSION

- i. Turn the dial on the top end of the oil reservoir to the 2 position.
- ii. Count the number of drips for 1 minute.
- iii. Adjust between settings up or down to reach the desired drip rate.



#### JELPC Brand - SCREW VERSION

- i. Using a flat head screwdriver, turn the screw clockwise until it is closed.
  - ii. Open the screw by turning counterclockwise a 1/4 turn.
  - iii. Adjust by turning screw slowly in either direction to reach the desired drip rate.
- 7) PRESSURE ADJUSTMENT:



Pull up on the regulator knob and adjust the pressure to 100 psi. Pressure should be set between 90 - 120 psi.

- 8) Reconnect all airlines and check system for air leaks.

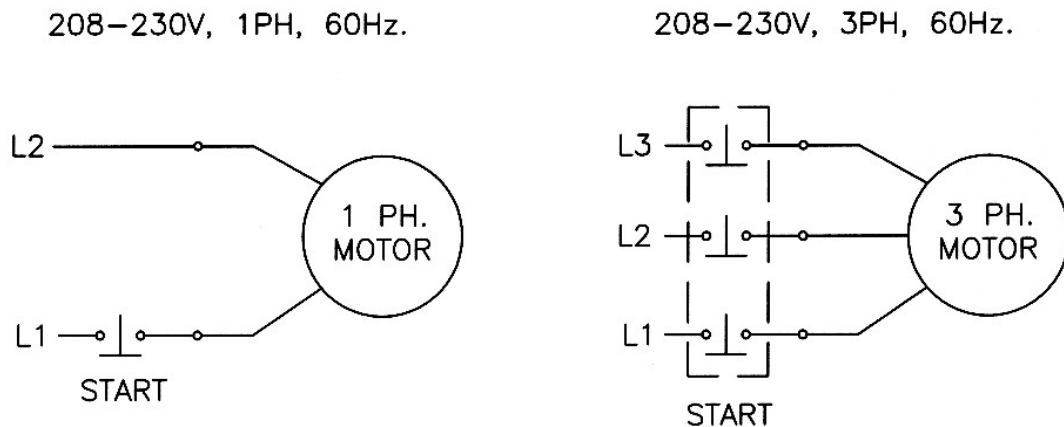
## 6.19 ELECTRICAL CONNECTIONS



**A QUALIFIED ELECTRICIAN SHOULD MAKE ALL ELECTRICAL CONNECTIONS.**

Refer to **Figure 65** for electrical connections.

Electrical Breaker must be sized by a qualified electrician. Refer to page 7 for electric motor ratings.



**Figure 65 – Electrical Diagram**

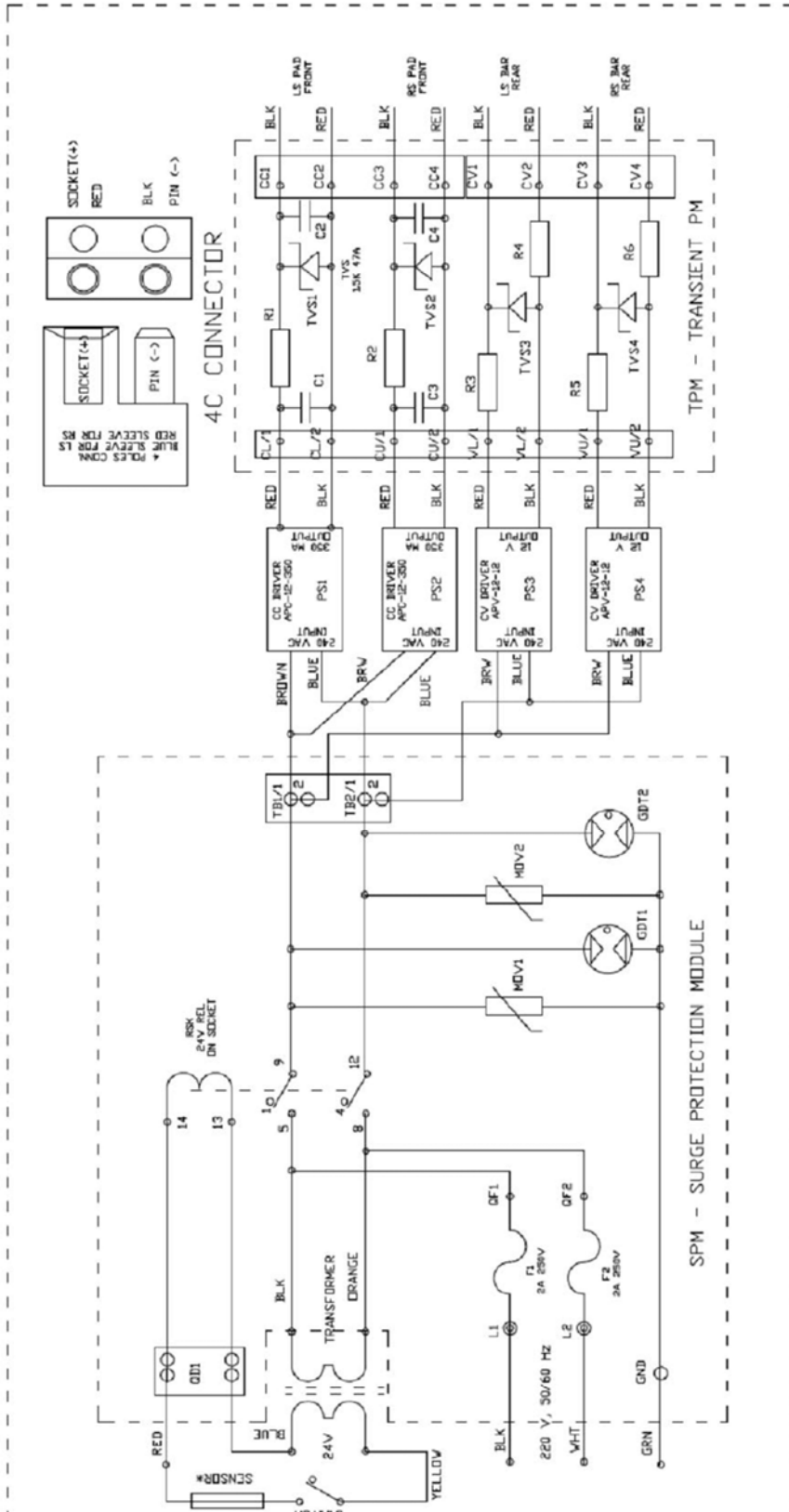
## 6.20 LIGHTS & LOCKS CONTROL BOX (OPTIONAL)

Refer to **Fig. 66** for electrical schematic on control box.

An electrician is to connect the control box leads (wht/grn/blk) into the box on the power pack.



Figure 66 –Electrical Diagram (OPTIONAL)



## 6.21 LIGHTS & LOCKS CONTROLS (OPTIONAL)

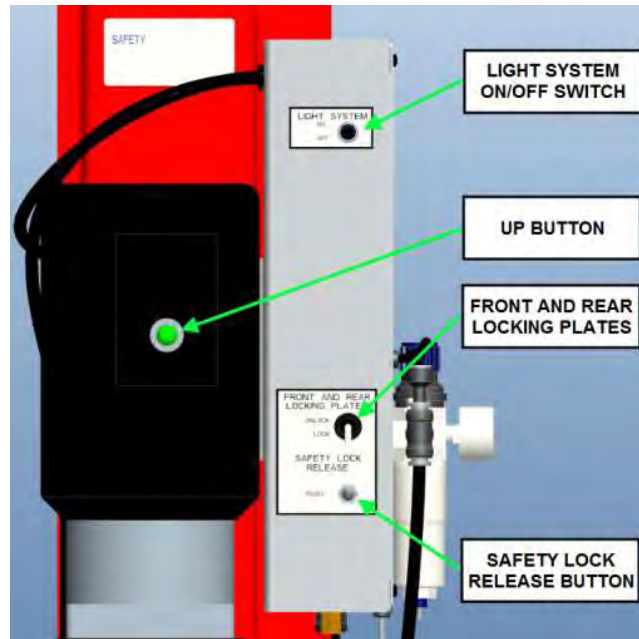


Figure 67

### 6.21.1 The Light System

1. The light system will illuminate after approximately 24" of travel from the ground and will turn off at the same height, please verify.
2. If you desire to have the light system off at any height above the 24", you can do so by turning the switch on the control box to the "off" position, please verify.
3. If not, check that all connections are correct and there is current to the control box.

### 6.21.2 Locking Plate System

4. On the control box, switch the Locking Plate lever to "OFF" to unlock. All locking plates should be free to move, please verify.
5. Now switch the lever to "ON" to lock. All locking plates should be centered and locked, please verify.
6. If not, check that all polytubes connections are correct and there is 90-120psi of air pressure.

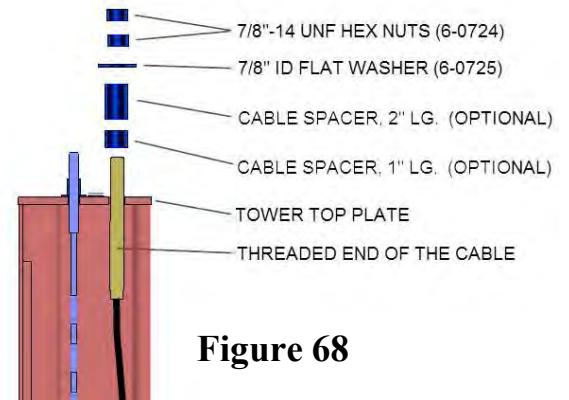
## 6.22 DECK LEVELING PROCEDURE

### 6.22.1 Leveling Lift on the floor

- Lower the lift completely to the floor.
- Determine the highest corner of the lift and adjust remaining towers to level the lift, front-to-back and side-to-side (see positions 1, 2, 3, 4 in **Fig. 68**). Use shims under tower base plate, as needed.

### 6.22.2 Leveling Safety Ladders:

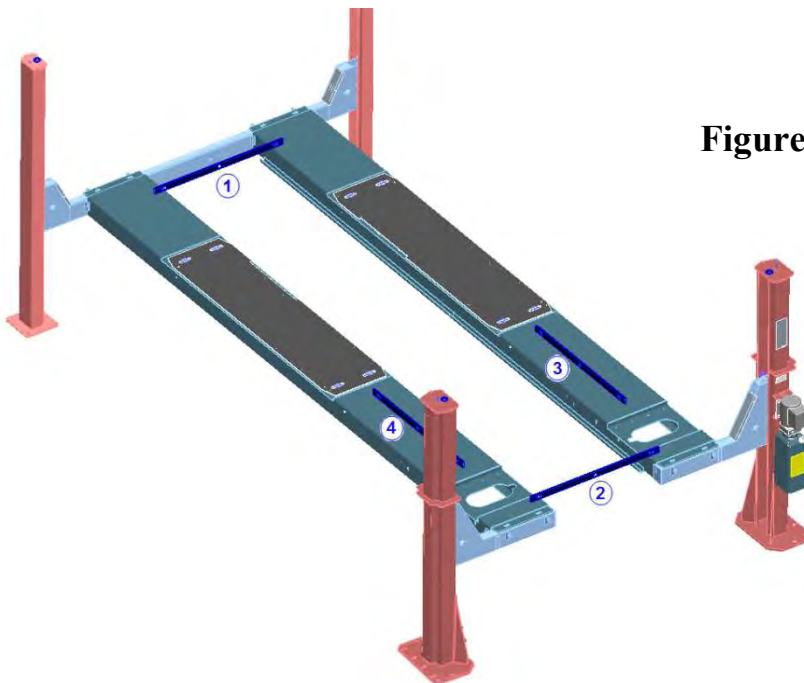
- Raise the lift to a comfortable working height using the hydraulic power pack.
- Lower the lift onto the nearest safety.
- Using a 4' level, check the level of the decks front to rear and side to side as shown in **Fig.69**.
- Determine the highest corner of the lift.
- The other 3 corners will need to be raised to the level of the highest corner. This is accomplished by tightening the safety ladder retaining nuts on the top of the tower.



**Figure 68**

**NOTE:** The lower safety ladder retaining nuts will need to be tightened to jam. It may be easier to remove the cable to gain access to the lower safety ladder retaining nuts. Re-install the cable once the adjustment is complete.

- Repeat this procedure for all 3 corners while checking the level of the decks.



**Figure 69 – Deck Leveling**

### 6.22.3 Leveling Lift on Cables:

- Raise the lift off the safety ladders, at a comfortable working height.
- Using a 4' level, check the level of the decks front to rear and side to side as shown in **Fig.69**
- Determine the highest corner of the lift.
- The other 3 corners will need to be raised to the level of the highest corner. This is accomplished by tightening the cable retaining nut on the top of the tower.

**NOTE:** There should be two nuts retaining the cable to the top plate of the tower. The upper nut is used as a jam nut to prevent the lower nut from loosening. Both nuts should be installed after the adjustment is completed.

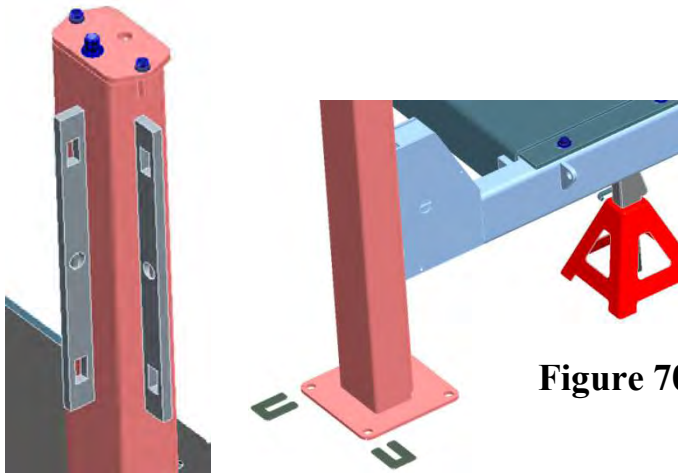
- Repeat the preceding steps until the lift is completely level when supported by the cables. Tighten the jam nut after the adjustment is completed.
- Make sure that the non-threaded sleeve of each wire rope seats in the cable flange properly (See **Fig.45.a, Fig.45.b**, chapter **6.10**).
- Raise the lift and check that the ladders engage evenly.
- Lower the lift onto a mechanical safety position. Raise the lift from this position and ensure the lift rises evenly and level from the mechanical locks.

### 6.23 ANCHOR REAR TOWERS

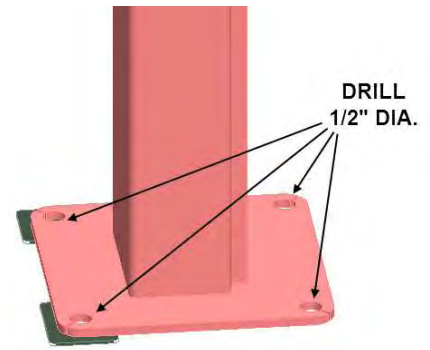
- Before proceeding, check that the layout dimensions on Figure 1 and Figure 2 before continuing with anchor installation. Measure diagonally lift dimensions over 2 decks, and distance between decks, and then tighten decks to cross-members. Diagonal distances should be equal within 1/4".
- At this stage, the rear towers may be slightly off line "D". Check if rear towers are centered with respect to chalk lines "E" and "F", and adjust if necessary.
- Use a 4' level, to level the posts vertically (shim if necessary) as shown in **Figure 70**.

**NOTE:** IF THE TOWERS ARE LEANING INTO THE LIFT, THE CROSS-MEMBERS CAN BECOME WEDGED INTO THE TOWERS AS THE LIFT RAISES.

- Prior to installing anchors, assemble the nut and washer onto anchors. A minimum of six threads must be visible below the surface of the nut. Refer to the **Figure 15** for anchoring instructions.
- If shop floor is not level, determine which rear tower sits on higher floor.
- Using a 1/2" concrete drill bit and rotary hammer drill, drill 1/2" holes for the anchor bolts on the (high side) column. Drill completely through the concrete floor. (**Fig.71**). In case longer anchors are required, supplied anchors can be hammered through concrete



**Figure 70**

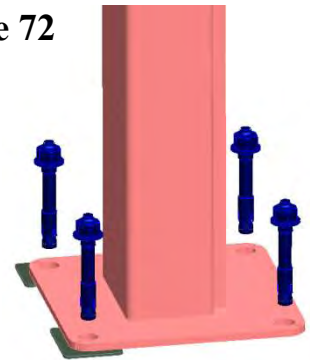


**Figure 71**

Clean out the drilling dust from the holes and hammer in the anchor bolts until they make contact with the base plate. Tighten all anchor bolts (**Fig.72**).

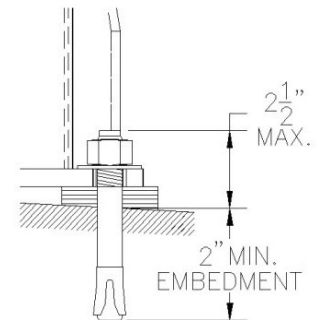
- Check that the column is level front to rear and side to side. Adjust shims as required.
- Ensure that the base plate is completely supported by shims, including near the center, where it does not contact the floor. If excessive shimming (greater than 5/16") is required, grout or additional support is required under the towers.
- Torque all anchor bolts to 55 ft-lbs. (75 Nm), continually checking that the column is level as you proceed. **Do not exceed tightening torque.**

**Figure 72**



**NOTE:** The 1/2" × 4½" lg. wedge anchor bolts supplied must have a minimum embedment of 2" into the concrete floor.

**NOTE:** If anchors do not tighten to required torque, OR project more than 2-1/2" above the concrete surface due to floor slope, contact a foundation engineer to determine the best course of action.



**NOTE:** In cases where the floor is extremely out of level, the mechanical safety latches may not engage on the same lock

**⚠ WARNING** DO NOT use more than 1/2" (13mm) of shims. Anchor bolts supplied allow for a maximum of 1/2" (13mm) of shim. If more than 1/2" (13mm) of shims are required, DO NOT proceed with installation and contact Snap-on Equipment Technical Support for further details.

**NOTE:** Refer to Bay Layout to ensure that the column is still in the proper position.

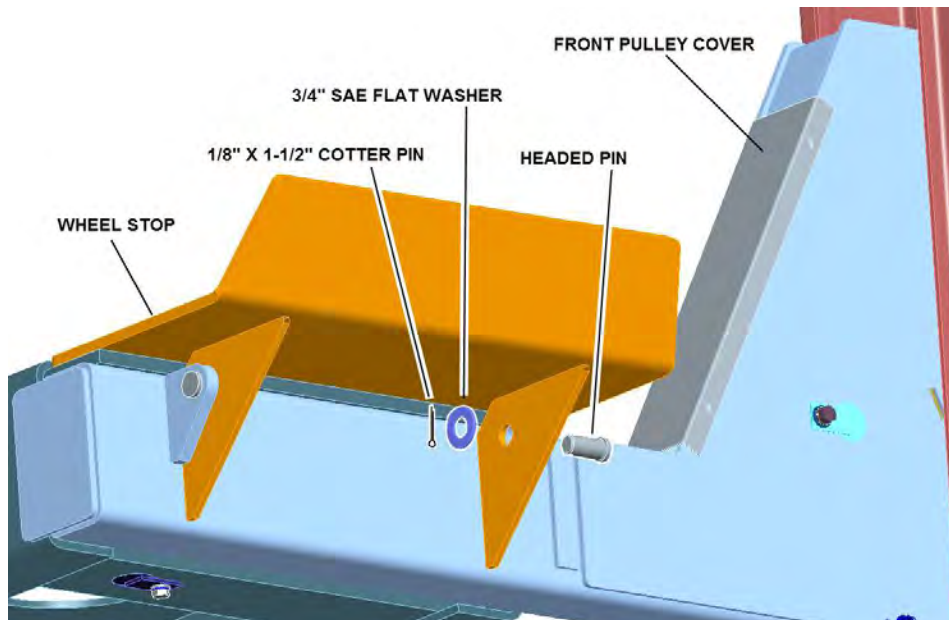
- Repeat procedure for the other rear tower.

**NOTE:** THE 40" DIMENSION SHOWN IN FIGURE 1 AND FIGURE 2 IS CRITICAL, AS IT IS NECESSARY TO ALLOW THE JACKING BEAMS TO ROLL FREELY.

## 6.24

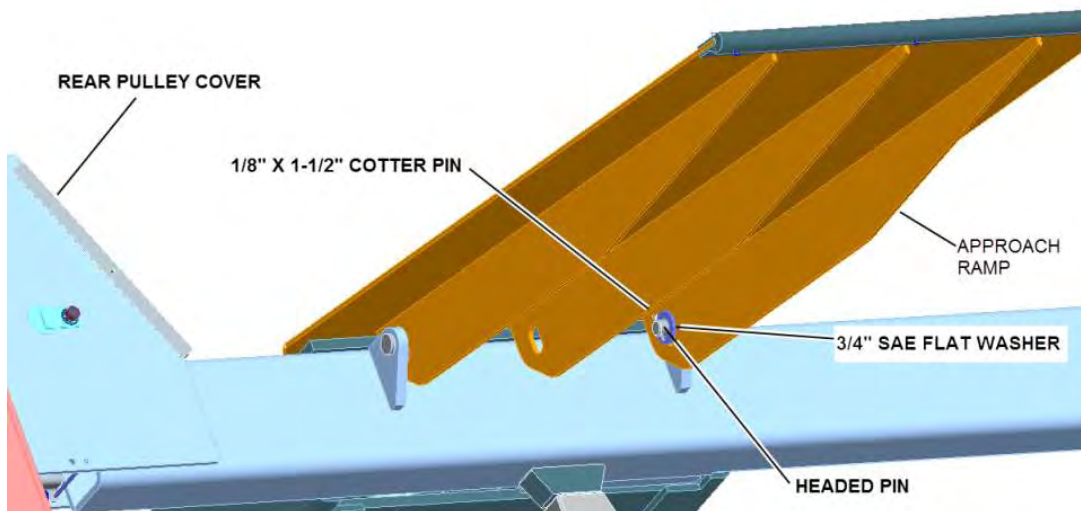
### APPROACH RAMPS, WHEEL STOPS, PULLEY COVERS

- Retrieve the approach ramps, wheel stops and pulley covers from the accessory box. Install short pulley covers to rear cross-members. Install long pulley covers to front cross-members.
- Install the front wheel stops at the front of the decks, using  $\text{Ø}3/4''$  x 1-1/2'' LG headed pins,  $\text{Ø}3/4''$  SAE washers and  $\text{Ø}1/8''$  x 1-1/2 LG cotter pins (Qty.2 per each wheel stop).



**Figure 73**

- Headed pins are found in the accessory box. Cotter pins and washers are found in hardware kit.
- Install the approach ramps at the rear of the decks with  $\text{Ø}3/4''$  x 1-1/2'' LG headed pins,  $\text{Ø}3/4''$  SAE washers and  $\text{Ø}1/8''$  x 1-1/2 LG cotter pins (Qty.2 per each approach ramp). Install short pulley covers to both sides of rear cross-member.



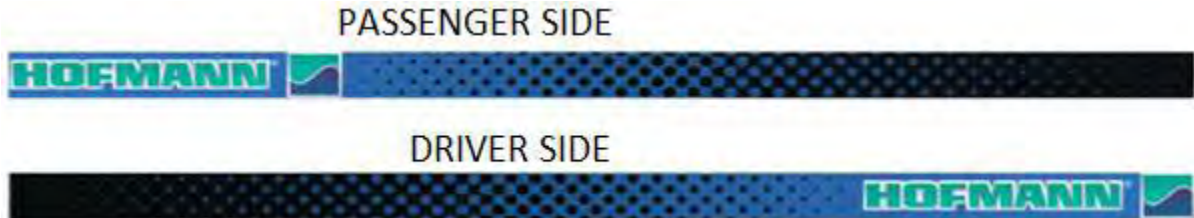
**Figure 74**

- Ensure the proper operation of the approach ramps.

## 6.25

### DECAL PLACEMENT AND CYCLE TESTING

- Clean the outside sides of the runways with rubbing alcohol, acetone, or another degreaser.
- Notice there are two Pinch Warning decals on the outside side of each runway, one towards the rear and one towards the front. Place the Large Hoffman Decals 2 inches from the rear Pinch Warning Decal on each side of the runway being careful to center the decal vertically. Note: it may help to use masking tape to template the location.



- Cycle the lift several times to check proper operation of the cables, safety lock, air locks, etc. with & without load.

### STOP IMMEDIATELY IF THE LIFT IS NOT OPERATING PROPERLY!

- Make any necessary adjustments and check again for proper operation.

**NOTE:** IF THE LIFT IS EQUIPPED WITH JACKING BEAMS, THIS IS THE APPROPRIATE TIME TO INSTALL THEM. CONSULT THE JACKING BEAM INSTRUCTION MANUALS FOUND IN EACH JACKING BEAM BOX.

**WARNING** Before attempting to operate the lift, please ensure that slider guide surfaces inside the front towers are greased adequately.

## 7. OPERATING INSTRUCTIONS

**WARNING** To avoid personal injury and/or property damage, permit only trained personnel to operate the lift.

After reviewing these instructions, get familiar with lift controls, by running the lift through a few cycles before loading vehicle on lift.

Observe and heed SAFETY and WARNING labels on the lift.

### LIFT OPERATION

- **Loading:** Lift must be fully lowered, and no one in the service bay while the vehicle is brought in. If the lift is equipped with rolling jacks, jacks must be fully lowered and the rear jack pushed toward center of lift, to provide under-car clearance.
- Stop vehicle before it contacts the front wheel stops. At all times, be sure the rear wheels are forward of the approach ramps/chocks and the approach ramps/chocks will clear the tires when the lift is raised. Driver must exit the vehicle before rising.
- Place triangular wheel chocks on front and rear of one of the rear tires.
- **To raise the lift:** Push the “RAISE” button on the power unit. Release button at desired height, ensure that all corners have passed a mechanical lock position.

- After raising the lift to the desired height, press and hold the lowering lever on the hydraulic power unit, until lift stops on safety latches. Cross-members should be stopped on safety latches in all 4 towers before any work can start on the raised vehicle. If any of the safety latches is not engaged, try to raise or lower the lift to the next higher or lower safety position, and observe again if all 4 safety latches have engaged. If the problem persists, lower and unload the vehicle, solve the lift safety problem, and only then resume vehicle service.
- **Before lowering lift:** be sure no one is in the lift area and that all tools, tool trays, etc. have been removed from under the lift and vehicle. If the lift is equipped with rolling jacks, jacks must be fully lowered and the rear jack pushed toward center of lift, to provide under-car clearance.

**⚠ WARNING**

The runways, approach ramps, and cross-members are designed to rest on the floor when fully lowered. Observe pinch point warning decals.

- **To lower lift:** if lift has been resting on the safety latches, the lift has to be raised high enough for all 4 safety latches to clear the openings in the latch plate (safety ladder).
- Actuate the latch release valve on the power unit column to disengage all four locking latches. Hold actuator until lift is fully lowered.

NOTE: If actuator on air valve is released, the latches will automatically reset to the engaged position.

- Push the lowering handle on the power unit to lower the lift.
- Observe lift and vehicle to be sure lift is level while being lowered. If not, STOP the lift and try to resume lowering as explained above.
- Fully lower lift, remove the triangular wheel chocks and check to be sure area is clear before removing vehicle from lift.
- If lift is not operating properly, do not use until adjustment or repairs have been made by qualified lift service personnel.
- For Rolling Jack operating instructions, see Rolling Jack Installation, Operation and maintenance Instructions in the rolling jack shipping box.

**⚠ WARNING**

Do not operate lift with pulley covers removed from cross-member ends. Keep hands clear of the cross-member ends when lift is being raised or lowered.

**⚠ WARNING**

Do not raise or lower the lift while the jack beams are loaded.

## 8. RECOMMENDED INSPECTION AND MAINTENANCE

### 8.1 LUBRICATION SPECS

Where hydraulic oil is required	> ISO 32 10W - non detergent hydraulic oil
Where grease is required	> multi-purpose lithium grease
Where multipurpose lube is required	> multi-purpose SAE 30 lubricating oil
Where pneumatic oil is required	> Snap-On air motor oil IM1PT



Where cable lube is required

> NYROSTEN SEIOLOL wire rope lubricant or equivalent  
(Part # for ordering: **EAK0299T71A**)

**⚠ WARNING** If you are not completely familiar with automotive lift maintenance procedures, STOP. Contact Snap-on Equipment Technical Support for instructions. To avoid personal injury, permit only qualified lift service personnel to perform maintenance on this equipment.

**Always** raise lift when cleaning floor area with solvents and/or cleaning compounds.

**Always** replace cable break safety springs when replacing cables.

Please refer to the following table for specific inspection and maintenance frequency.

COMPONENT	INSPECTION FREQUENCY					
	DAILY	WEEKLY	MONTHLY	QUARTERLY	SEMI-ANNUALLY	ANNUALLY
Entire Lift and surrounding area	8.15					As shown before, and ALI Standard
Entire Lift Operation	8.15					
Fasteners		8.3				
Wire Ropes		8.2.3	8.2.4	8.2.5		
Sheaves		8.4.1		8.4.2		
Sheave Pins		8.4.3		8.4.2		
Safety Dogs	8.5		8.3			
Slack Cable Devices	8.6					
Latch Plates (Ladders)			8.6			
Air Filter, Regulator, Lubricator	8.7.1					
Air Lubricator Oil Level	8.7.2					
Approach Ramps, Chocks, Wheel Stops	8.12					
Anchor Bolts			8.11.2			
Turn Tables and Rear Slip Plates	8.13.1		8.13.2	8.13.3	8.13.5	
Bearing Cage / Rear Slip Plates	8.13.1		8.13.2	8.13.4	8.13.5	
Edges of Cable Flange Slots	8.2.6					
Runways			8.10.1			
Columns			8.11.1			
Air cylinders, Lines, Fittings			8.7			
Hydraulic Power Pack, Hose, Fittings			8.8			8.8

Hydraulic Cylinder				8.9		
Jack Beam Rails, Oil Drain Pan				8.10.2		
Anti-skid Surfaces				8.13.5		
Rolling Air Jacks			8.14			

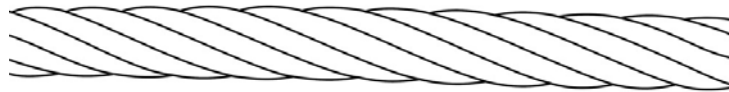
## 8.2 WIRE ROPES

### **⚠ WARNING**

- Wire ropes are critical to safe and reliable performance of your lift.
- Cables are expendable items and should be replaced as a set.

### 8.2.1 WIRE ROPE CONDITIONS GUIDE

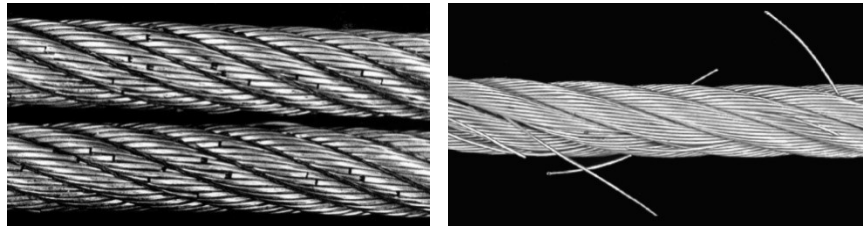
Typical good cable



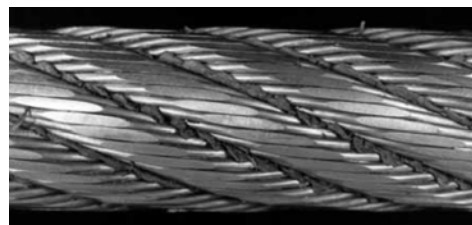
Cable with necking



Broken wires



Excessive wear of wires



Rust on sheave stack and ropes



Corrugated sheave groove



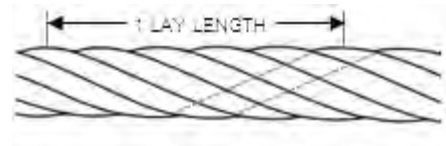
**Figure 75**

## 8.2.2 WIRE ROPE REPLACEMENT CRITERIA:

### **⚠ WARNING**

If any cable is found to be in need of replacement, the entire cable set, pulleys and safety rollers must be replaced immediately. See 8.2.1, cable conditions guide.

In the following table, "lay" means the distance measured along a line parallel to the axis of the rope in which the strand makes one complete turn about the axis of the rope, or the wires make a complete turn about the axis of the strand.



<i>The wire rope must be removed from service if one or more of the following criteria are met:</i>
1. More than six randomly distributed broken wires in one rope lay or 6×d length.
2. More than three broken wires in one strand in one rope lay or 6×d length.
3. Three or more broken wires at rope terminations.
4. One outer wire broken at the point of contact with the core of the rope which has worked its way out of the rope structure and protrudes or loops out from the rope structure
5. Heavy rusting, corrosion, or pitting. A light surface corrosion on outer wires is normal.
6. Wear or scraping of one-third of the original diameter of outside individual wires
7. Excessive stretch. It is normal for new cable to require adjustment during “break-in”, after which small periodic adjustments may be required. However, if a cable that has been in service for 6 months should suddenly require frequent adjustments or has used all the cable adjustment available, all cables must be replaced immediately.
8. Deformed strands, kinking, crushing, bird-caging, or any other damage or distortion of wire rope structure
9. Variations in diameter (necking) or any change from normal appearance
10. Reductions from nominal diameter of more than 1/32" (for cables 3/8" to 1/2" dia. inclusive)
11. End attachments cracked, deformed or worn

## 8.2.3 WIRE ROPE INSPECTION

Inspect wire rope cables for wear or damage. Wipe cables with a rag to detect hard to see small broken or frayed cable strands. See chapter 8.2, Fig.75 and ANSI/ALI ALOIM standard.

## 8.2.4 WIRE ROPE LUBRICATION

Lubricate wire ropes with lift in both lowered and raised position, by spraying them with wire rope lubricant (i.e. NYROSTEN SEIOL).

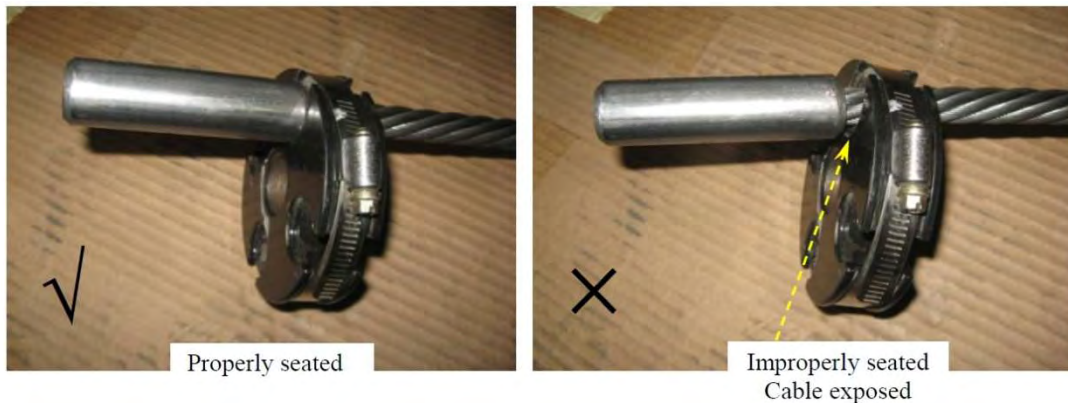
### 8.2.5 WIRE ROPE ADJUSTMENT

Adjust cables if lifting is uneven or lift is not level (See chapter 6.15.3). Never make adjustments with weight on lift. If running out of adjustment threads, cables need to be replaced. Do not add washers or other spacers to re-use previously used adjustment threads.

Wire rope tension adjustment should be performed when installing the lift and every three months.

### 8.2.6 INSPECT CABLE FLANGE

Make sure the edges of the counter-bores in the cable flange are not damaged or worn, indicating that cable sleeves may not be properly seated at all times.



### 8.3 FASTENERS

Check all the attaching bolts and nuts for tightness.

Note: Air cylinder bolts and nuts should allow movement of the cylinder.

### 8.4 SHEAVES AND PINS

Sheaves and pins are expendable items. Sheaves and pins should be replaced when worn. Use of sheaves and pins with excessive wear will lead to reduced service life of the cables.



Bushings inside sheaves work best in “dry” condition. Applying oil will diminish their performance and greases will degrade performance even further. **DO NOT GREASE SHEAVE BUSHINGS OR SHAFTS.**

#### 8.4.1 VISUAL INSPECTION OF SHEAVES

- Check sheaves and replace if cracks or other damage are found.
- Visually inspect alignment of sheaves. Misalignment of sheaves indicates excessive wear. Remove, inspect, and, if needed replace sheave and pin.

#### 8.4.2 MEASURE SHEAVE WEAR

- Inspect sheaves in cross-members with lift in lowered position and resting on safety latches
- Place safety stands under front and rear cross-members. Stop lift on mechanical safety locks. One person should hold the lowering handle on power unit down while another person pulls on cables in each column to create slack in cables.
- Check for ease of rotation. If sheaves do not turn freely, the sheave and sheave pin should be removed, inspected, fixed or replaced.
- Fully raise the lift, to inspect sheaves in runways. Hold lowering handle down to lower lift onto safety latches
- Pull on cables in runway to create slack in cables.

- Check all sheaves for excessive wobble, or movement. Grasp rim of sheave and attempt to wobble (tilt) side to side. If sheaves wobble (tilt) more than 3/16” (1.6 mm) side to side, or move in and out more than 1/32 (0.8 mm), the sheave and sheave pin (shaft) should be replaced. Replace immediately if needed.

### 8.4.3 SHEAVE PINS

Sheave pins are held in place by a Hex Head Bolt, washer and lock washer.

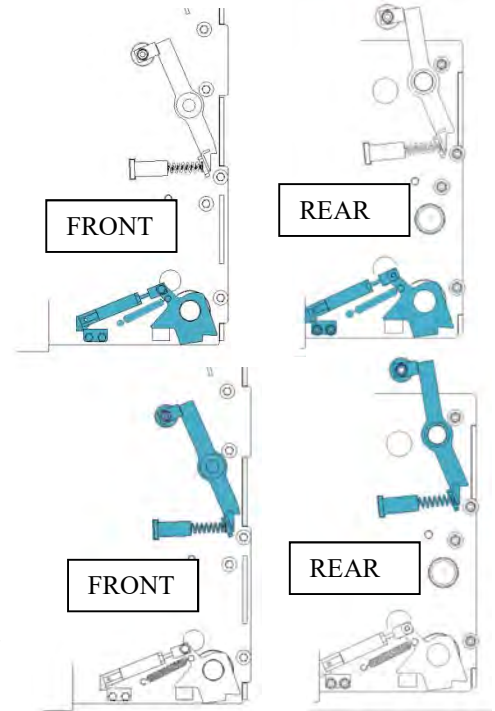
Check for loose sheave pins, loose or missing fasteners to hold sheave pins in place. Remediate situation immediately.

### 8.5 MECHANICAL SAFETY LATCHES (DOGS)

Watch and listen to safety latch operation during lift operation, to ensure that latches move as required, have not lost spring preload, and line up with slots in latch plates (safety ladders) in columns.

Watch for broken traction springs on safety latches.

Check and adjust safety ladders if lift is not level on safety, or if safeties do not engage properly. Stop using the lift if any malfunction or damage is observed.



### 8.6 CABLE BREAK SAFETY MECHANISM

With lift not loaded, all four cable break levers should produce deflection of the lift cables.

Inspect slack cable device as follows:

Check for missing or damaged parts. Watch for broken springs.

Check if the spring is properly seated in the support tube and in the holder on the cable break safety lever. Watch cable tracking properly on cable break safety roller. Check if the safety roller and bolt are properly attached to the cable break safety lever. Verify that the cable break safety lever is centered within the cross-member, and that it lines up with the openings in the safety ladder. Verify using hand force or a light lever that the cable break safety lever pivots on the shaft. Lubricate with light lubricant if required.

### 8.7 AIR CYLINDERS, AIR LINES, VALVE AND FITTINGS

#### 8.7.1 GENERAL CHECKS

Check filter/regulator/lubricator in supply line to lift. (customer supplied, typically at compressor).

Drain water trap filter bowl and adjust oil feed according to manufacturer’s instructions. Refer to

Drain water bowl on lift supplied water separator. Press valve at the bottom of the bowl to clear.

Check operation of air release valve for air leaks.

Check air cylinders for visible damage.

Check air lines for leaks, wear or kinks.

#### 8.7.2 AIR LUBRICATOR OIL LEVEL

**NOTE:** Failure to maintain oil level in lubricator will **void warranty** of all pneumatic components.

## MAINTENANCE

- Refill oil reservoir using instructions detailed in Section 6.18 before the oil level reaches the MIN OIL line on the reservoir.
- Recheck drip rate after refilling.
- Check pressure is adjusted to 100 psi.
- The FRL unit is autodrainng. However, you can drain the water trap filter bowl by pressing valve at the bottom of the bowl until all water has drained.



### 8.8 HYDRAULIC POWER PACK AND HOSE

Check all air and hydraulic hoses, fittings and cylinders for leaks.

Check level of oil in power pack reservoir when lift is in the lowered position. Add if required.

Check fluid level of lift power unit and refill if needed. If refill was needed, inspect all fittings, hoses and seals. Tighten, repair or replace as required.

Change hydraulic fluid every 2 years.

### 8.9 HYDRAULIC CYLINDER

Inspect the hydraulic cylinder mounting to the runway. Inspect cylinder and hydraulic hose for leaks. Repair or replace as required.

Check and tighten the hydraulic cylinder rod nuts holding the cable flange.

Inspect bolts holding anti-rotation bar onto cable flange and tighten if required. (If applicable)

Inspect sliders on anti-rotation bar for excessive wear or damage. Replace if required. (If applicable)



#### **WARNING**

Failure to do so will lead to reduced service life, which could result in property damage and/or personal injury.

### 8.10 RUNWAYS

#### 8.10.1 CHECK RUNWAYS

Check level of runways on the floor, on the locks and on the cables: Refer to **Section 6.15**. Adjust as required.

Check runways for damage or abnormal deformation. If such conditions exist, contact Snap-on Equipment Technical Support.

#### 8.10.2 INSPECT JACK BEAM TRACKS

Inspect rolling jack / oil drain pan tracks for cleanliness, corrosion, excessive wear or damage. Clean dirty tracks. Worn or damaged tracks should be repaired immediately.

## 8.11 COLUMNS

### 8.11.1 CHECK COLUMNS

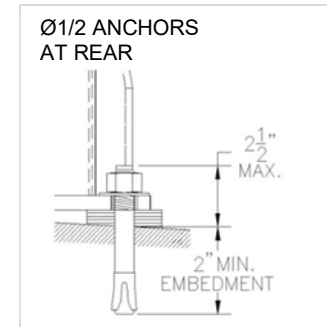
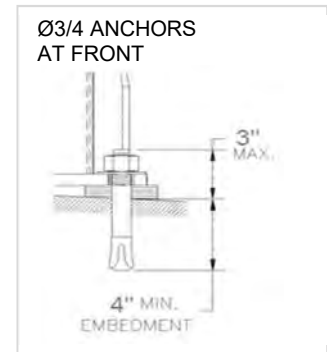
Check columns for corrosion, giving special attention to the area at the base of the column. Check severely corroded areas by pecking with an awl or welder's chipping hammer. If column is corroded through at any point, it must be replaced immediately. If not corroded through, remove old paint and rust scale, then coat with a high quality corrosion resistant paint. Clean and lubricate glide blocks.

### 8.11.2 CHECK COLUMN ANCHORS

Check column anchor bolts for tightness. If loose, re-torque front anchors to 110 ft-lb and rear anchors to 55 ft-lb. If anchors do not tighten to required torque, or continue to loosen, contact Snap-on Equipment Technical Support. Verify proper embedment of anchors after tightening.

**NOTE:** The  $\text{Ø}3/4'' \times 7''$  wedge anchors supplied must have a minimum embedment of 4'' and the  $\text{Ø}1/2'' \times 4\frac{1}{2}''$  wedge anchors supplied must have a minimum embedment of 2'' into the concrete floor.

**NOTE:** If anchors do not tighten to required torque, OR if  $\text{Ø}3/4''$  anchors project more than 3'' above the concrete surface, OR if  $\text{Ø}1/2''$  anchors project more than  $2\frac{1}{2}''$  above the concrete surface due to floor slope, contact a foundation engineer to determine the best course of action.



## 8.12 APPROACH RAMPS, CHOCKS, FRONT WHEEL STOPS

Inspect for excessive wear or damage. Repair or replace if required. Inspect hinge pins. Replace if excessively worn. Lubricate if in good condition

## 8.13 FRONT AND REAR STEER PLATES

### 8.13.1 VISUAL INSPECTION

Check front turn tables and rear slip plates for unusual deflection, damage, fluid spills. Clean or further inspect if needed.

### 8.13.2 CLEAN REAR SLIP PLATES AND FRONT TURN TABLES

Clean foreign debris from front turn tables and rear slip plates by blowing out with compressed air. Check and clean steer plates. Lubricate with oil or light grease.

### 8.13.3 MAINTENANCE OF REAR STEER PLATES

Inspect the non-skid coating on rear slip plates for wear. All areas found to be worn smooth should be resurfaced with an Anti-Slip abrasive floor tread tape or a heavy duty Anti-Slip Floor Coating.

Remove rear slip plate covers. Clean runway surface and touch up any paint wear with a rust resistant paint. Allow paint to dry thoroughly. Inspect transfer balls for excessive wear, deformations or corrosion. Inspect plastic pads (pucks) for excessive wear or deformation. Replace if needed.

### 8.13.4 MAINTENANCE OF REAR STEER PLATES - IF EQUIPPED WITH PLASTIC BEARING CAGE.

Remove top Slip Plate covers by first removing the four (4) shoulder bolts on each cover. Remove polyethylene-bearing cages insuring that all the Delrin bearings remain in the cages. Additional Delrin bearings may be purchased if required.

Clean runway surface and touch up any paint wear with a rust resistant paint. Allow paint to dry thoroughly.

To obtain optimum performance, the position of the slip-plate bearing cage should be rotated every quarter to change the wear pattern.

With the first quarter maintenance, flip the bearing cage over to the opposite side.

With the second quarter maintenance, rotate the bearing cage end-to-end.

With the third quarter maintenance, flip bearing cage over to the opposite side.

Fourth quarter maintenance should see the bearing cage rotated back to the original position.

Quarterly maintenance will optimize performance and contribute to longer slip plate life.

### 8.13.5 ANTI-SKID COATING ON REAR STEER PLATES

Inspect the non-skid coating on rear steer plates for wear. All areas found to be worn smooth should be resurfaced with an Anti-Slip abrasive floor tread tape or a heavy duty Anti-Slip Floor Coating.

## 8.14 ROLLING AIR JACKS

Lubricate roller bearings and roller guide springs.

Dismantle and clean lift arms.

Clean and lubricate rollers/sliders and hinge points.


Clean and lubricate safety mechanism.

Change hydraulic oil every two years

## 8.15 ENTIRE LIFT

Wire ropes, columns, runways and other lift parts should be kept free of corrosive agents, solvents, and road salts. If such agents are spilled or splashed on any lift component, immediately rinse thoroughly with water and wipe down with a clean rag. Lubricate again wire rope as shown at 9.2.4.

Check general operation of lift. Observe any structural noise, imbalance, binding, or other malfunctions.

 Failure to keep the lift free of corrosive agents and solvents will lead to reduced component service life, cable failure, etc., which could result in property damage and/or personal injury.



## **9. LIFT LOCKOUT / TAGOUT PROCEDURE**

### **9.1 PURPOSE**

This procedure establishes the minimum requirements for the lockout of energy that could cause injury to personnel by the operation of lifts in need of repair or being serviced. All employees shall comply with this procedure.

### **9.2 RESPONSIBILITY**

The responsibility for assuring that this procedure is followed is binding upon all employees and service personnel from outside service companies (i.e. Authorized Snap-on Installers, contractors, etc.). All employees shall be instructed in the safety significance of the lockout procedure by the facility owner/manager. (or assigned designee) in the purpose and use of the lockout procedure.

### **9.3 PREPARATION**

Employees authorized to perform lockout shall ensure that the appropriate energy isolating device (i.e. circuit breaker, fuse, disconnect, etc.) is identified for the lift being locked out. Other such devices for other equipment may be located in close proximity of the appropriate energy isolating device. If the identity of the device is in question, see the shop supervisor for resolution. Assure that proper authorization is received prior to performing the lockout procedure.

### **9.4 SEQUENCE OF LOCKOUT PROCEDURE**

- a. Notify all affected employees that a lockout is being performed and the reason for it.
- b. Unload the subject lift. Shut it down and assure the disconnect switch is "OFF" if one is provided on the lift
  - If this is a lockable device, the authorized lockout person places the assigned padlock on the device to prevent its unintentional reactivation. An appropriate tag is applied stating the person's name, at least 3"x6" in size, an easily noticeably color, and states not to operate device or remove tag.
  - If this device is a non-lockable circuit breaker or fuse, replace with a "dummy" device and tag it appropriately as mentioned above.
- c. Attempt to operate lift, to assure that lockout is working. Be sure to return any switches to the "OFF" position.
- d. The equipment is now locked and ready for the required maintenance or service.

### **9.5 RESTORING EQUIPMENT TO SERVICE**

- a. Assure the work on the lift is complete and the area is clear of tools, vehicles, and personnel.
- b. At this point, the authorized person can remove the lock (or dummy circuit breaker or fuse) and tag, and activate the energy isolating device so that the lift may again be placed into operation.

### **9.6 RULES FOR USING THE LOCKOUT PROCEDURE**

Use the Lockout Procedure whenever the lift is being repaired or serviced, waiting for repair when current operation could cause possible injury to personnel, or for any other situation when unintentional operation could injure personnel. No attempt shall be made to operate the lift when the energy isolating device is locked out.

## 10. PARTS LIST

### 10.1 PARTS LIST - LIFT ASSEMBLY

**NOTE:** For spacer locations and shim layout, please see page 28.

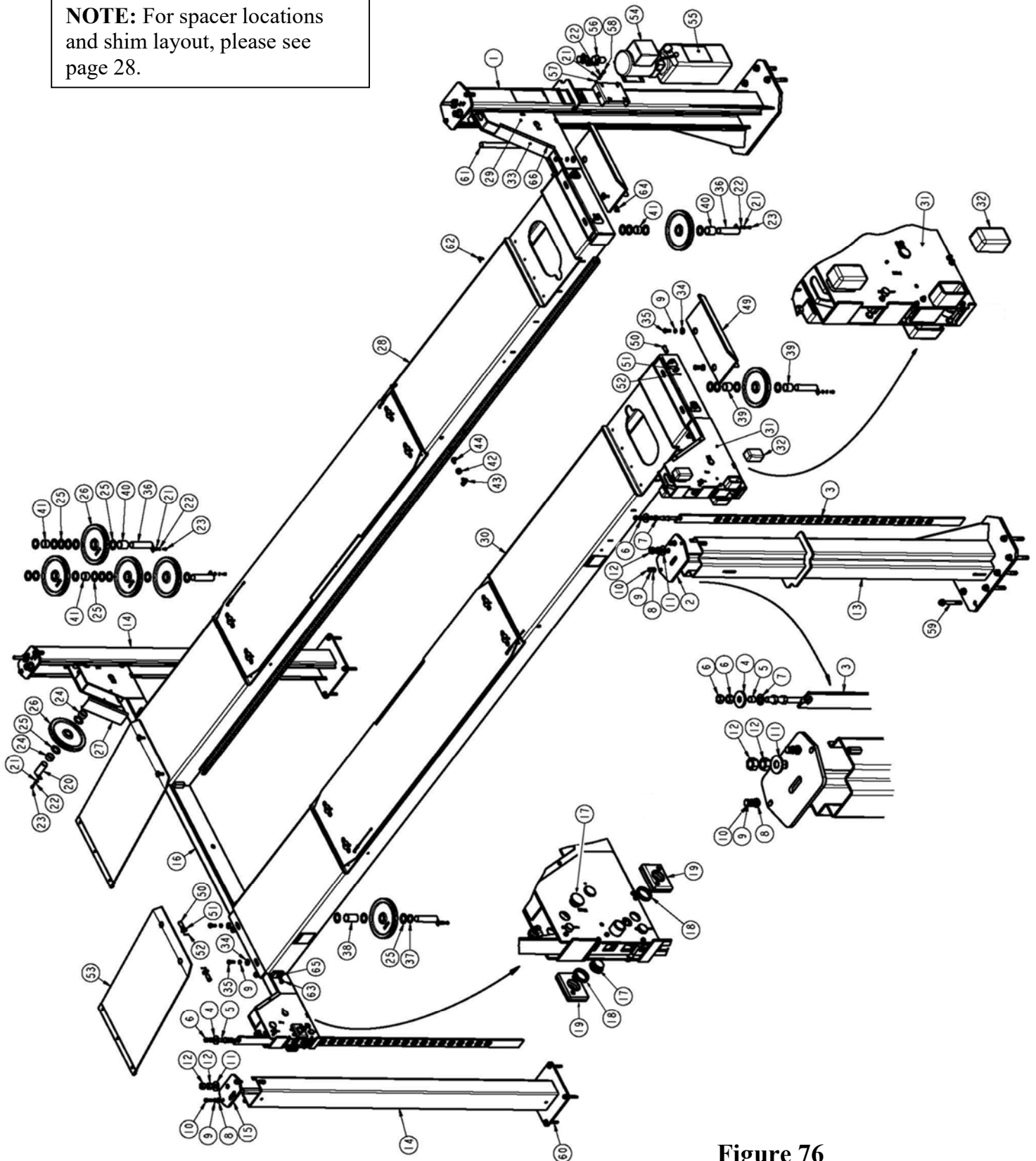
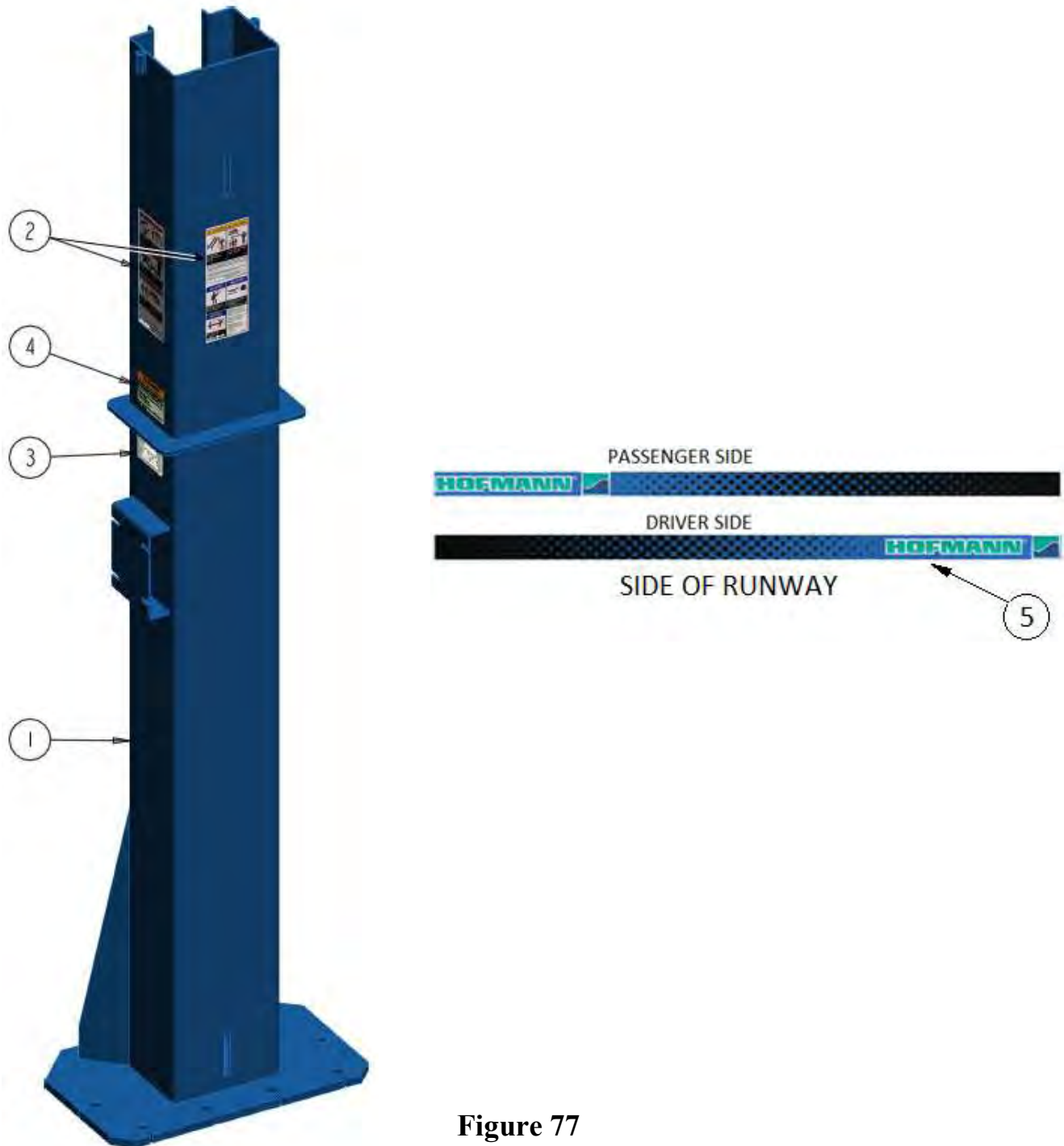


Figure 76

ITEM #	PART #	DESCRIPTION	QTY
1	4-1454	TOWER ASSY, FRONT, POWER	1
2	1-3810	TOP PLATE- WELDMENT	2
3	3-1082	SAFETY RACK WELDMENT	4
4	1-3932	WASHER, 11/16 X 2 X 1/4	4
5	1-3931	SPACER	4
6	6-0673	5/8" HEX NUT, GRADE 8	16
7	6-1401	WASHER, FLAT, 5/8 DIA	4
8	6-0248	FLAT WASHER, 1/2 ID SAE	8
9	6-0059	LOCK WASHER, 1/2"	16
10	6-0047	HEX HD BOLT, 1/2-13 x 1-3/4 LG, GR.5, PL	8
11	6-0725	7/8 ID FLAT WASHER	4
12	6-0724	HEX NUT, 7/8"-14 UNF	8
13	4-1447	FRONT POST WELDMENT, SLAVE	1
14	2-2928	REAR TOWER WELDMENT	2
15	2-2856	TOP PLATE-FLAMECUT	2
16	4-1423	REAR TRAVERSE BEAM ASSEMBLY	1
17	1-4002	PLASTIC INSERT	4
18	1-3872	SPACER, REAR SLIDER	4
19	2-2725	GLIDE BLOCK	4
20	1-3862	CROSSMEMBER SHEAVE PIN	4
21	6-0295	FLAT WASHER, 5/16" I.D.	13
22	6-0674	LOCK WASHER, 5/16" I.D.	13
23	6-0423	HEX BOLT, 5/16"-18UNC x 3/4" LG.	9
24	1-3863	SHEAVE SPACER, 7/8", CROSS-MEMBER	8
25	1-0757	NYLON THRUST WASHER	36
26	2-2927	SHEAVE ASSEMBLY, 10"	11
27	2-2852	PULLEY COVER, REAR	2
28	4-1334	DECK ASSEMBLY, LS, ALIGNMENT	1
29	4-1327	FRONT CROSSMEMBER ASSY, LS	1
30	4-1333	DECK ASSEMBLY, RS, ALIGNMENT	1
31	4-1326	FRONT COSSMEMBER ASSY, RS	1
32	2-0772	SLIDER BLOCK	8
33	2-2848	PULLEY COVER, FRONT	2

ITEM #	PART #	DESCRIPTION	QTY
34	6-0063	FLAT WASHER, 1/2"	8
35	6-0291	HEX BOLT, 1/2"-13UNC X 1-1/2 LG	8
36	2-0566	DECK SHEAVE PIN	5
37	1-3875	SHEAVE SPACER	1
38	1-3874	SHEAVE SPACER	1
39	1-3876	SPACER, FRONT, RS, TOP	2
40	1-3878	SHEAVE SPACER	2
41	1-3936	SHEAVE SPACER 1-1/8" LG	3
42	6-0713	TERMINAL BOLT, 3/4", SHORT	1
43	6-3896	PNEUMATIC TEE FITTING	1
44	6-3010	90 ELBOW. PNEU. 1/4"NPT M 3/8" F, PUSH	1
45	2-2914	LEFT FRONT CABLE, 398.25" LG	1
46	2-2933	LEFT REAR CABLE 165.5" LG	1
47	2-2916	RIGHT REAR CABLE 224.75" LG	1
48	2-2917	RIGHT FRONT CABLE, 450.25 LG	1
49	2-2868	WHEEL STOP WELDMENT	2
50	1-1887	HEADED PIN	8
51	6-0738	FLAT WASHER 3/4" SAE	8
52	6-0267	COTTER PIN, 1/8" DIA. x 1" LG	8
53	3-1089	APPROACH RAMP ASSY	2
54	6-1398	POWER PACK, 208-230V, 1PH	1
55	6-4045	FOUR POST OPERATING INSTRUCTIONS	1
56	2-1394	AIR VALVE & AIR FILTER ASSY	1
57	6-0294	HEX NUT, 5/16-18 UNC	4
58	6-0293	HEX HEAD BOLT, 5/16-18UNC x 1" LG	4
59	6-4044	WEDGE ANCHOR 3/4" x 7" LG	12
60	6-0140	WEDGE ANCHOR 1/2" x 4-1/2 LG	8
61	6-0714	HOSE GUARD	1
62	6-3998	TREE MOUNT CABLE TIE, 8" LG	18
63	6-0769	1/2-13 x 2" HEX HD BOLT GR5	4
64	6-2971	FITTING, TEE, 1/4" POLYTUBE	1
65	6-1295	NUT, JAM 1/2-13 UNC	4
66	6-1134	SCREW, #12 X 1/2"	12

## 10.2 PARTS LIST – FRONT TOWER ASSEMBLY, POWER



**Figure 77**

Item #	Part #	Description	Rev	Qty.
1	4-1454	POST WELDMENT, FL	-	1
2	6-0988	DECAL SET, ALI/WL 200	-	1
3	6-1637	SAFETY DECAL	-	1
4	6-4086	WARNING DECAL, DECK LEVELING	C	1
5	6-4321	HOFMANN DECAL	-	1

### 10.3 PARTS LIST – REAR CROSS-MEMBER

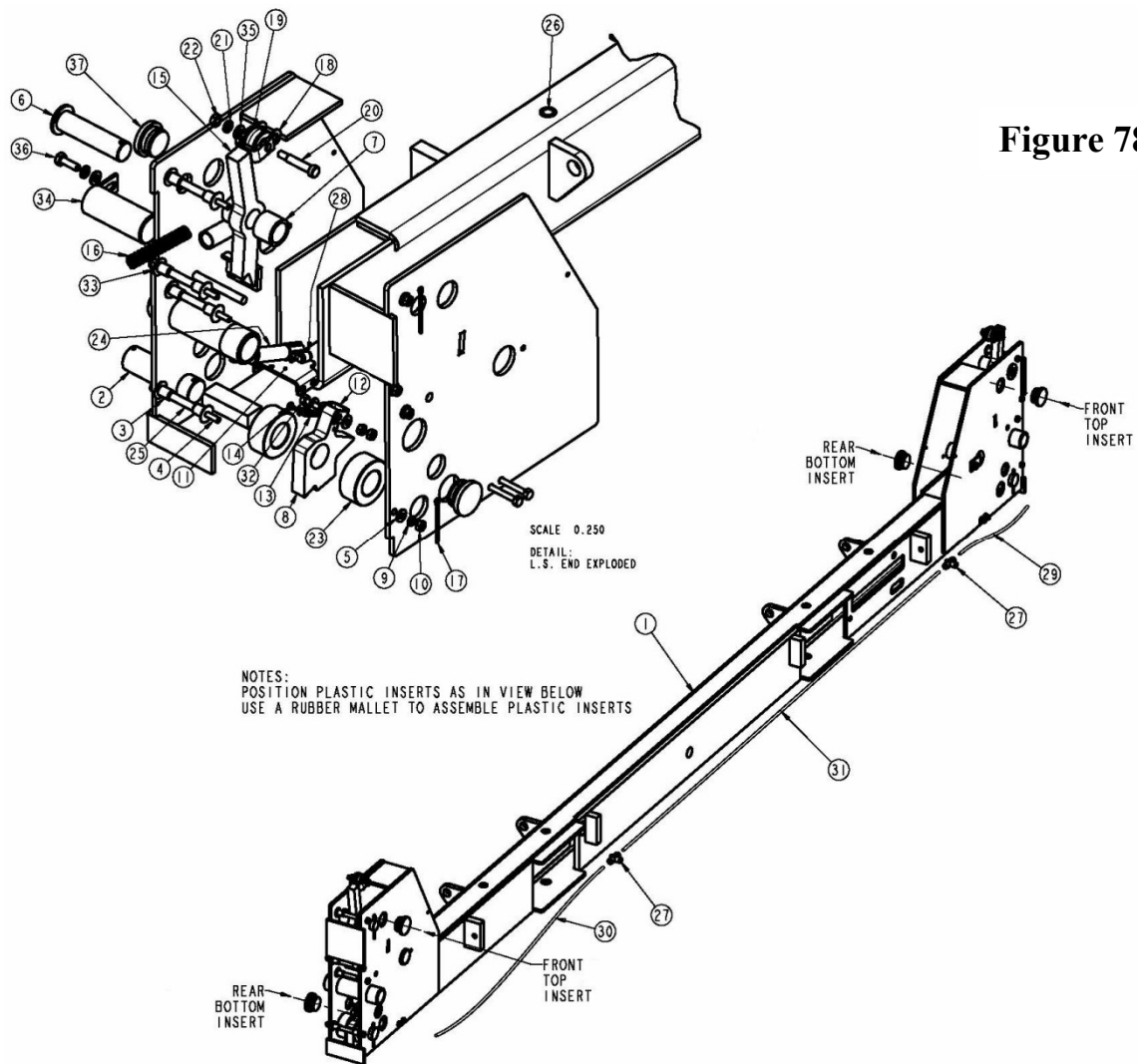


Figure 78

ITEM #	PART #	DESCRIPTION	QTY.	ITEM #	PART #	DESCRIPTION	QTY.
1	4-1422	REAR CROSSMEMBER, WELDMENT	1	19	1-3953	CABLE ROLLER ASSEMBLY	2
2	1-3891	LOCK SAFETY PIN	2	20	6-0801	SHOULDER BOLT, 3/8 x 1 1/2 LG.	2
3	6-3990	ROLLER, SAFETY LADDER	16	21	6-0674	LOCK WASHER, 5/16 I.D.	4
4	6-3997	HEX HD. BOLT, 1/4-20 UNC x 4" LG.	12	22	6-0294	HEX NUT, 5/16-18 UNC	2
5	6-0060	FLAT WASHER, 1/4" I.D.	16	23	1-3798	ROLLER RETAINER	4
6	1-3865	LOCK SAFETY PIN	2	24	6-3989	SAFETY CYLINDER	2
7	1-3812	SAFETY SPACER	4	25	1-3868	POLYTUBE SPACER	8
8	2-2847	SAFETY DOG	2	26	6-2432	THREADED INSERT, 1/2-13 UNC, 215-112	4
9	6-0056	LOCK WASHER, 1/4" I.D.	12	27	6-2971	FITTING, TEE, 1/4" POLYTUBE, PUSH-LOCK	2
10	6-0032	Hex Nut, 1/4"-20UNC	14	28	6-4040	ELBOW 90DEG 1/4" POLYTUBE - #10-32 UNF M	2
11	2-2898	CYLINDER MOUNT, WELDED	2	29	8-0141	POLYTUBE, 1/4" DIA x 0.038" WALL x 19" LG.	1
12	1-3935	ROD CLEVIS	2	30	8-0141	POLYTUBE, 1/4" DIA x 0.038" WALL x 30" LG.	1
13	1-1115	SAFETY SPRING	2	31	8-0141	POLYTUBE, 1/4" DIA x 0.038" WALL x 64" LG	1
14	6-0169	SCREW, SELF-TAPPING, #10 X 3/8 LG	2	32	6-0028	HEX HD CS, 1/4 20UNCx1 3/4" LG	2
15	2-2854	AUX. SAFETY WELDMENT, REAR	2	33	6-3882	WASHER, NYLON, 1/4 ID X 5/8 OD X 1/32 THK	16
16	6-4050	SAFETY SPRING	2	34	1-3862	CROSSMEMBER SHEAVE PIN	2
17	6-0115	COTTER PIN, 1/8 DIA X 2 LG	6	35	6-0295	FLAT WASHER, 5/16" I.D.	4
18	6-0062	FLAT WASHER, 3/8 ID SAE	4	36	6-0293	HEX HEAD BOLT, 5/16-18UNC x 1" LG.	2
				37	1-4002	PLASTIC INSERT	4

## 10.4 EXPLODED VIEW - LOCKS & LIGHTS (OPTIONAL)

### Rear Crossmember Assembly 4-1425

Item#	Part #	Description	Qty.
1	4-1424	REAR CROSSMEMBER WELDMENT	1
38	6-4125	CABLE HOLDER	3
39	6-1353	ROUND HEAD SCREW, 1/4-20UNC X 3/8 LG	3
40	6-4105	LIGHT CABLE ASSEMBLY	1
41	8-0372	POLYTUBE RED, 1/4" DIA x 0.038W" x 10FT	1
42	8-0373	POLYTUBE BLUE, 1/4" DIA x 0.038W" x 10FT	1

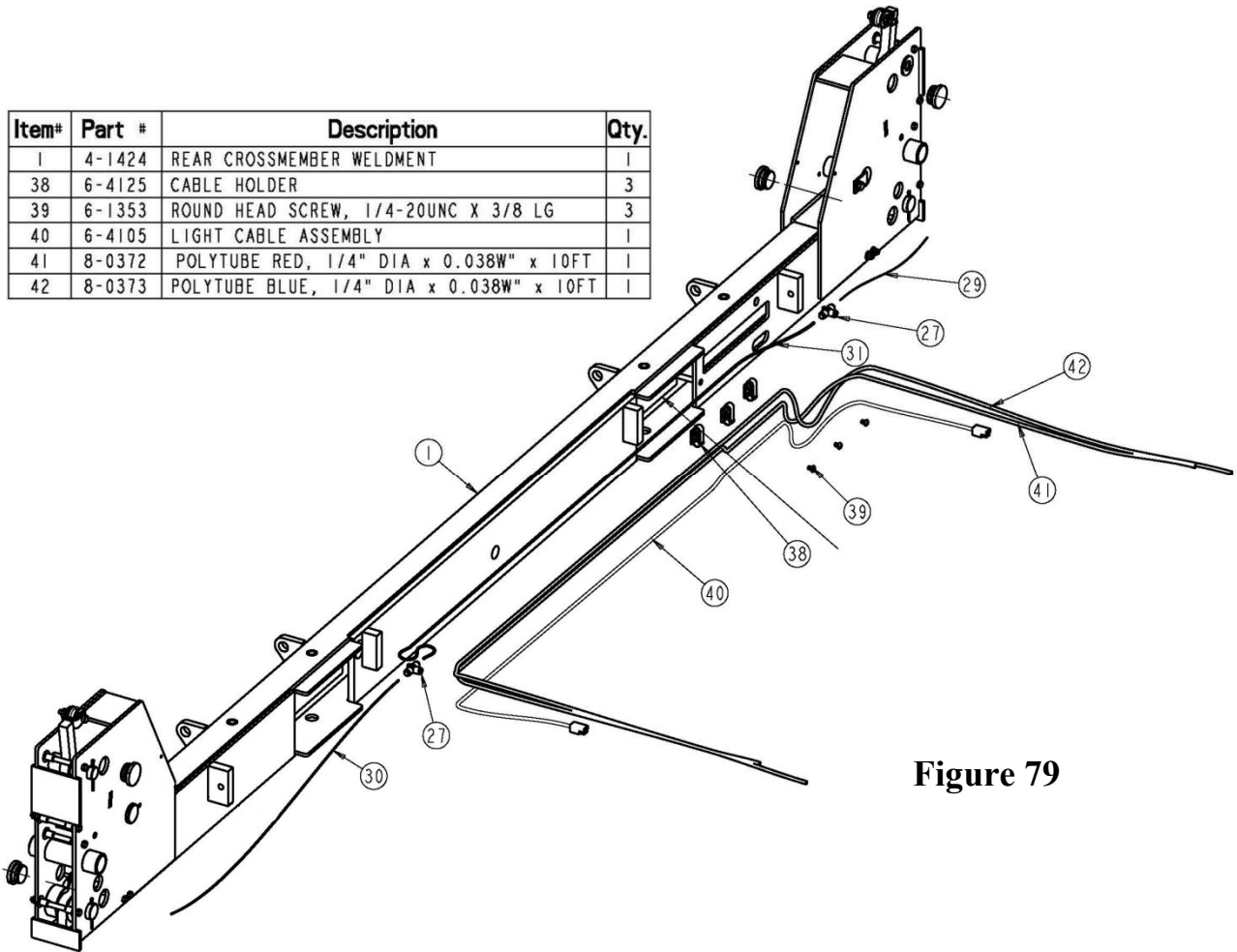
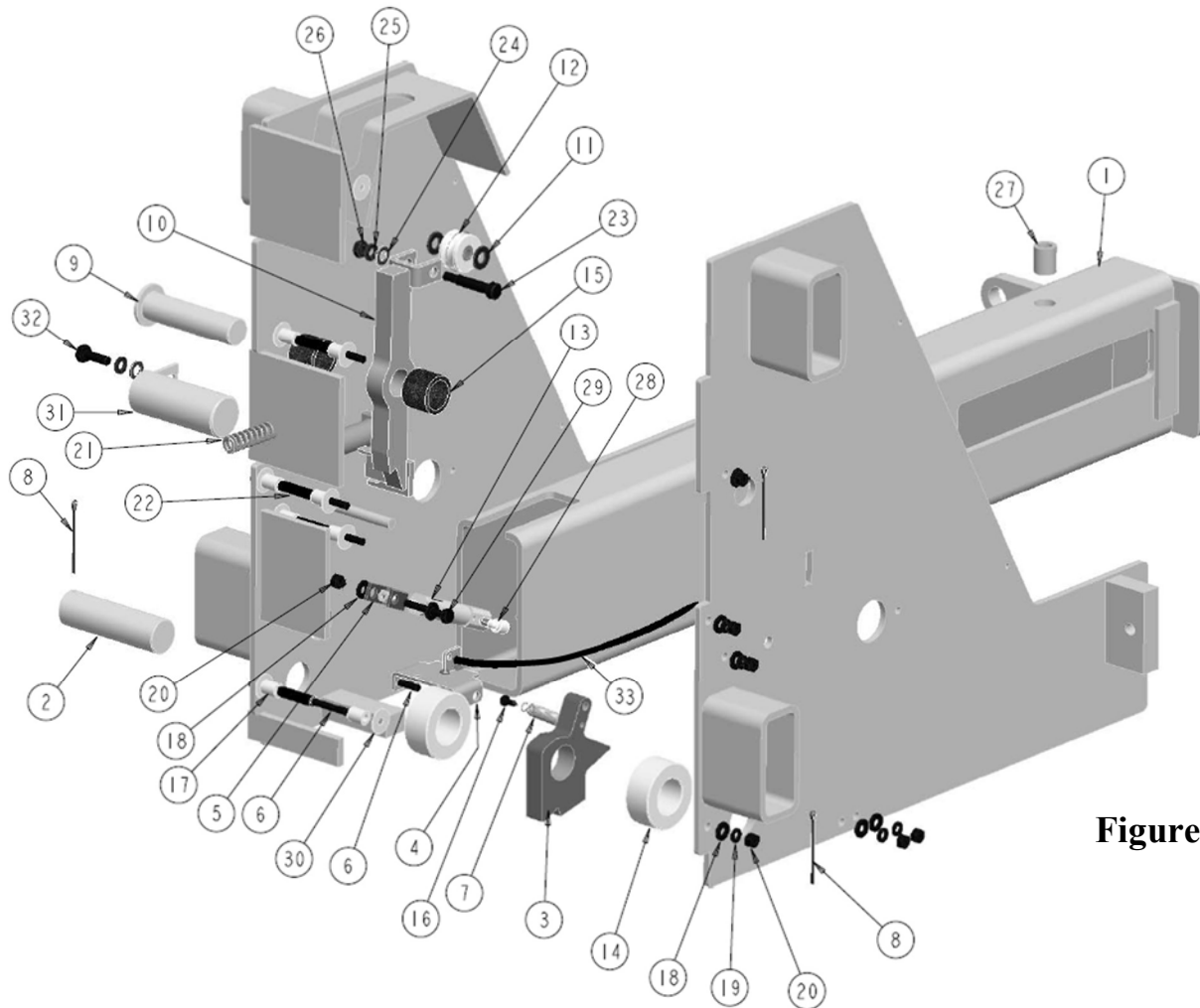


Figure 79

## 10.5 PARTS LIST – FRONT CROSS-MEMBER, LS



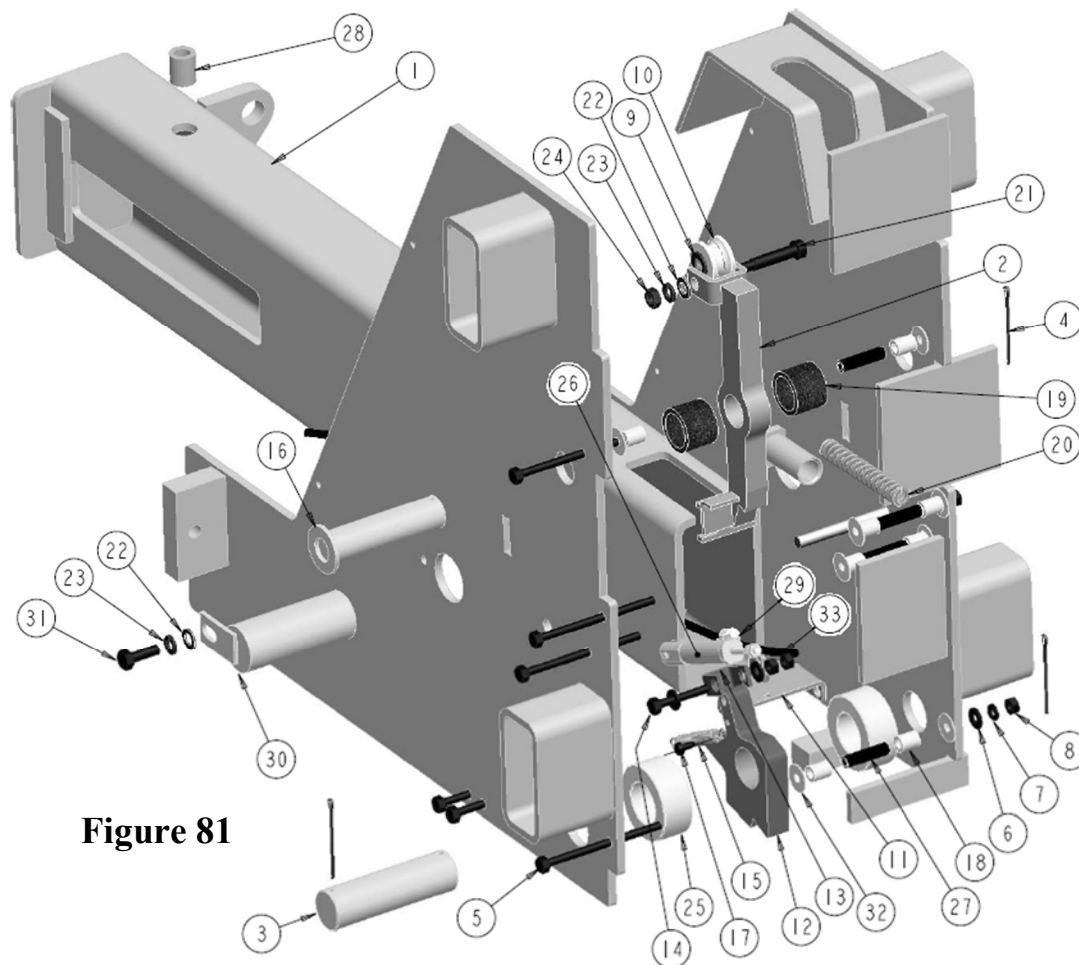
**Figure 80**

ITEM	PART	DESCRIPTION	QTY
1	4-1324	FR. CROSSMEMBER WELDMENT, LS	1
2	1-3891	LOCK SAFETY PIN	1
3	2-2847	SAFETY DOG	1
4	2-2898	CYLINDER MOUNT, WELDED	1
5	1-3935	ROD CLEVIS	1
6	6-3997	HEX HD. BOLT, 1/4-20 UNC x 4" LG.	6
7	1-1115	SAFETY SPRING	1
8	6-0115	COTTER PIN, 1/8 DIA x 2 LG	3
9	1-3865	LOCK SAFETY PIN	1
10	2-2845	AUX. SAFETY WELDMENT, FRONT	1
11	6-0062	FLAT WASHER, 3/8 ID SAE	2
12	1-3953	CABLE ROLLER ASSEMBLY	1
13	6-3989	SAFETY CYLINDER	1
14	1-3798	ROLLER RETAINER	2
15	1-3812	SAFETY SPACER	2
16	6-0169	SELF-TAPING SCREW, #10 X 3/8" LG	1
17	6-3990	ROLLER SAFETY LADDER	8

ITEM	PART	DESCRIPTION	QTY
18	6-0060	FLAT WASHER, 1/4" ID	8
19	6-0056	LOCK WASHER, 1/4" ID	6
20	6-0032	NYLOCK HEX NUT, 1/4-20UNC	4
21	6-4050	SAFETY SRPING	1
22	1-3868	POLYTUBE SPACER	4
23	6-0801	SHOULDER BOLT, 3/8x1-1/2 LG	1
24	6-0295	FLAT WASHER, 5/16" ID	2
25	6-0674	LOCK WASHER, 5/16" ID	2
26	6-0294	HEX NUT, 5/16-16 UNC	1
27	6-2432	THREADED INSERT, 1/2-13 UNC, 215-112	2
28	6-4040	ELBOW 90DEG 1/4" POLYTUBE-#10-32 UNF M	1
29	6-0028	HEX HD CS, 1/4-20UNC x 1-3/4" LG	1
30	6-3882	WASHER, NYLON 1/4 ID x 5/8 OD x 1/32 THK	9
31	1-3862	CROSSMEMBER SHEAVE PIN	1
32	6-0293	HEX HEAD BOLT, 5/16-18UNC x 1" LG	1
33	8-0141	POLYTUBE, 1/4" DIA x .038 WALL, BLK 40" LG.	1

**Service item not shown in figure:**  
6-4319 Rear Clevis Pin w/ Retainers (for item # 13)

## 10.6 PARTS LIST – FRONT CROSS-MEMBER, RS



**Figure 81**

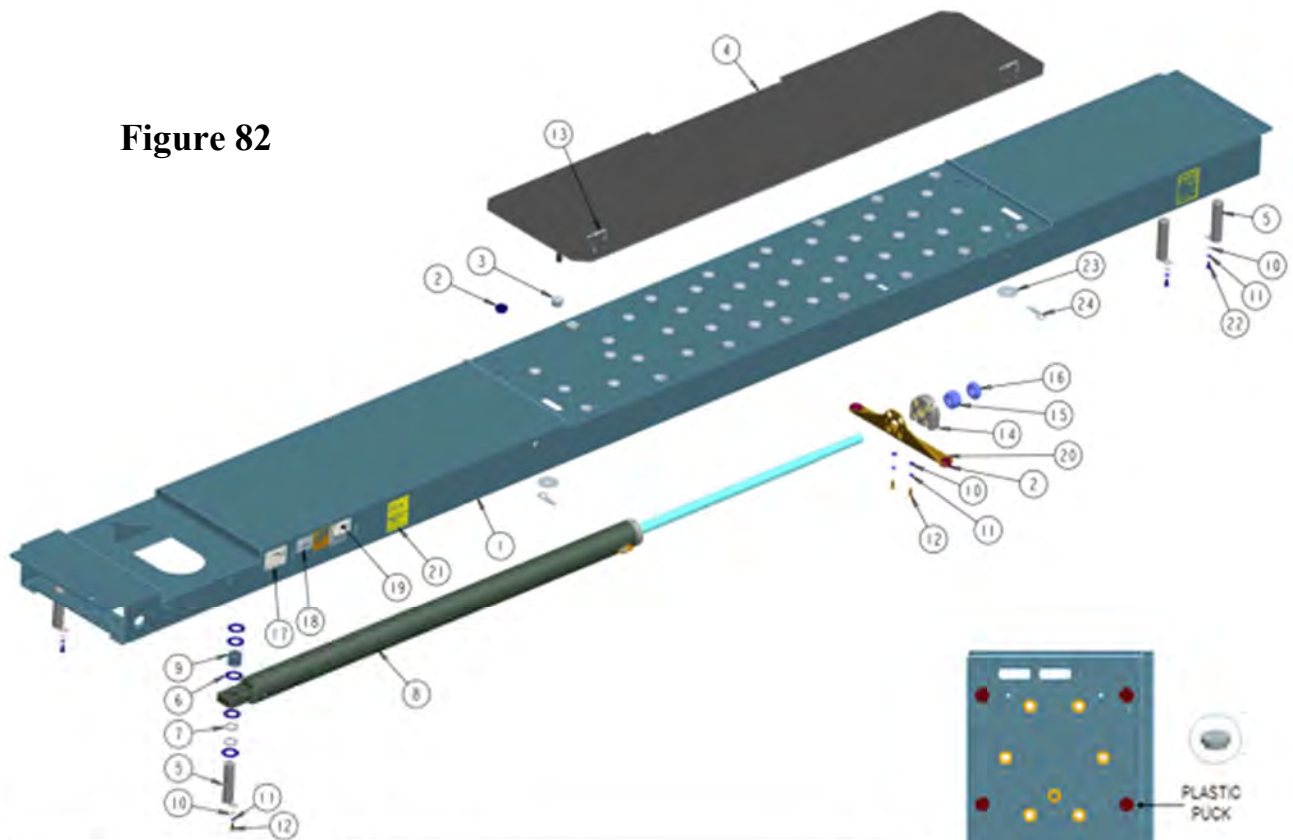
ITEM #	PART #	DESCRIPTION	QTY.	ITEM #	PART #	DESCRIPTION	QTY.
1	4-1325	FRONT CROSSMEMBER WELDMENT, RS	1	17	6-0169	SELF-TAPPING SCREW, #10 X 3/8" LG	1
2	2-2845	AUX. SAFETY WELDMENT, FRONT	1	18	6-3990	ROLLER, SAFETY LADDER	8
3	1-3891	LOCK SAFETY PIN	1	19	1-3812	SAFETY SPACER	2
4	6-0115	COTTER PIN, 1/8 DIA X 2 LG	3	20	6-4050	SAFETY SPRING	1
5	6-3997	HEX HD. BOLT, 1/4-20 UNC x 4" LG.	6	21	6-0801	SHOULDER BOLT , 3/8 x 1 1/2 LG.	1
6	6-0060	FLAT WASHER, 1/4" I.D.	8	22	6-0295	FLAT WASHER, 5/16" I.D.	2
7	6-0056	LOCK WASHER, 1/4" I.D.	6	23	6-0674	LOCK WASHER, 5/16 I.D.	2
8	6-0032	Hex Nut, 1/4"-20UNC	8	24	6-0294	HEX NUT, 5/16-18 UNC	1
9	6-0062	FLAT WASHER, 3/8 ID SAE	2	25	1-3798	ROLLER RETAINER	2
10	1-3953	CABLE ROLLER ASSEMBLY	1	26	6-3989	SAFETY CYLINDER	1
11	2-2898	CYLINDER MOUNT, WELDED	1	27	1-3868	POLYTUBE SPACER	4
12	2-2847	SAFETY DOG	1	28	6-2432	THREADED INSERT, 1/2-13 UNC, 215-112	2
13	1-3935	ROD CLEVIS	1	29	6-4040	ELBOW 90DEG 1/4" POLYTUBE - #10-32 UNF M	1
14	6-0028	HEX HD CS, 1/4 20UNCx1 3/4"LG	1	30	1-3862	CROSSMEMBER SHEAVE PIN	1
15	1-1115	SAFETY SPRING	1	31	6-0293	HEX HEAD BOLT, 5/16-18UNC x 1" LG.	1
16	1-3865	LOCK SAFETY PIN	1	32	6-3882	WASHER,NYLON,1/4 ID X 5/8 OD X 1/32 THK	8
				33	8-0141	POLYTUBE, 1/4 DIA X 0.038 WALL, BLACK, 40" LG	1

**Service item not shown in figure:**  
6-4319 Rear Clevis Pin w/ Retainers (for item # 26)

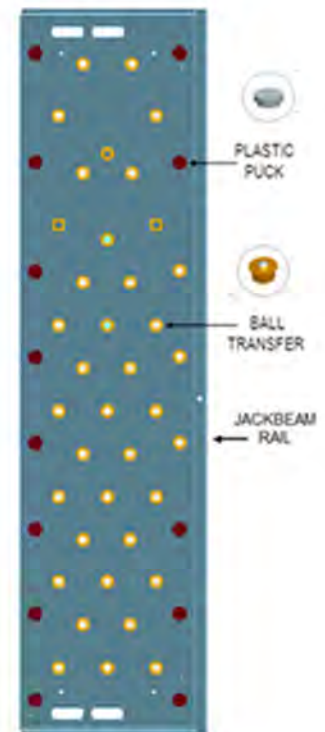


## 10.7 PARTS LIST - DECK ASSEMBLY, LEFT SIDE

Figure 82



Item*	Part *	Description	Qty.
1	4-1322	DECK WELDMENT, L.S.	1
2	1-3762	PLASTIC INSERT	15
3	6-3974	BALL TRANSFER	38
4	2-3035	SLIP PALTE WELD, L&L	1
5	2-0566	DECK SHEAVE PIN	4
6	1-0757	NYLON THRUST WASHER	5
7	1-3875	SHEAVE SPACER	2
8	4-1353	HYDRAULIC CYLINDER KIT	1
9	1-3876	SPACER, FRONT, RS, TOP	1
10	6-0295	FLAT WASHER, 5/16" I.D.	6
11	6-0674	LOCK WASHER, 5/16 I.D.	6
12	6-0293	HEX HEAD BOLT, 5/16-18UNC x 1" LG.	3
13	2-0637	LOCKING PIN ASSEMBLY	2
14	2-2866	CABLE FLANGE	1
15	6-3991	HEX NUT, 1-3/8 - 12 UNF	1
16	6-3992	HEX JAM NUT, 1-3/8 - 12 UNF	1
17	6-1763	CAPACITY DECAL, 12K OR 14K LB	1
18		MODEL NUMBER DECAL	1
19	6-2810	ALI GOLD DECAL	1
20	6-1637	SAFETY DECAL	1
21		ALI GOLD DECAL	1
22	1-3887	ANTI-ROTATION BAR, FORMED	1
23	KY089004	WARNING DECAL	2
24	6-0423	HEX BOLT, 5/16" - 18UNC x 3/4" LG.	3
25	1-4104	RETAINING WASHER	2
26	HP29	3/16" HITCH PIN X 3 1/2' LG	2



**NOTE:**  
When replacing plastic pucks and ball transfers, please follow the layout above

## 10.8 EXPLODED VIEW - LOCKS & LIGHTS (OPTIONAL)

### Deck Assembly, Left Side

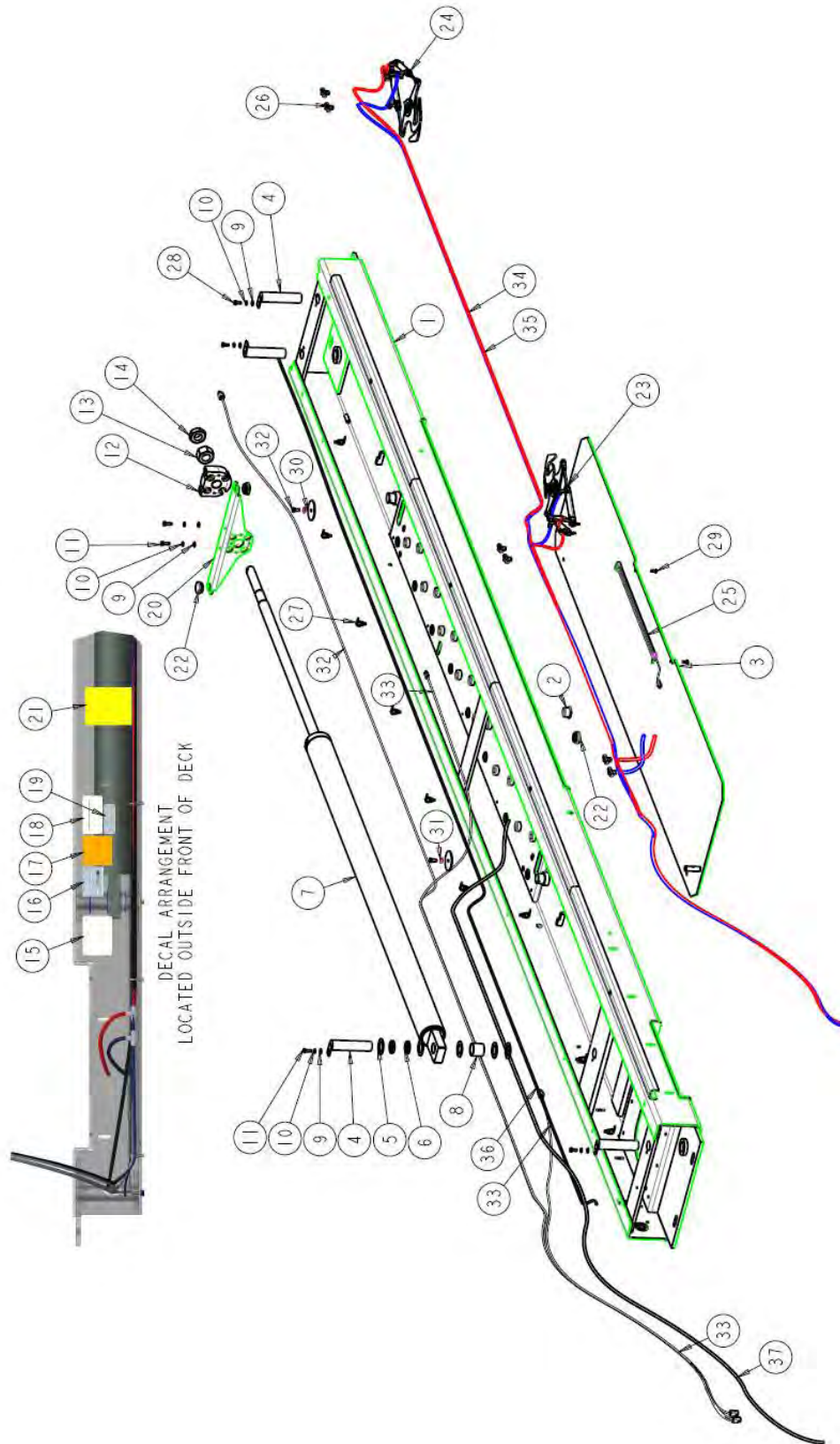


Figure 83

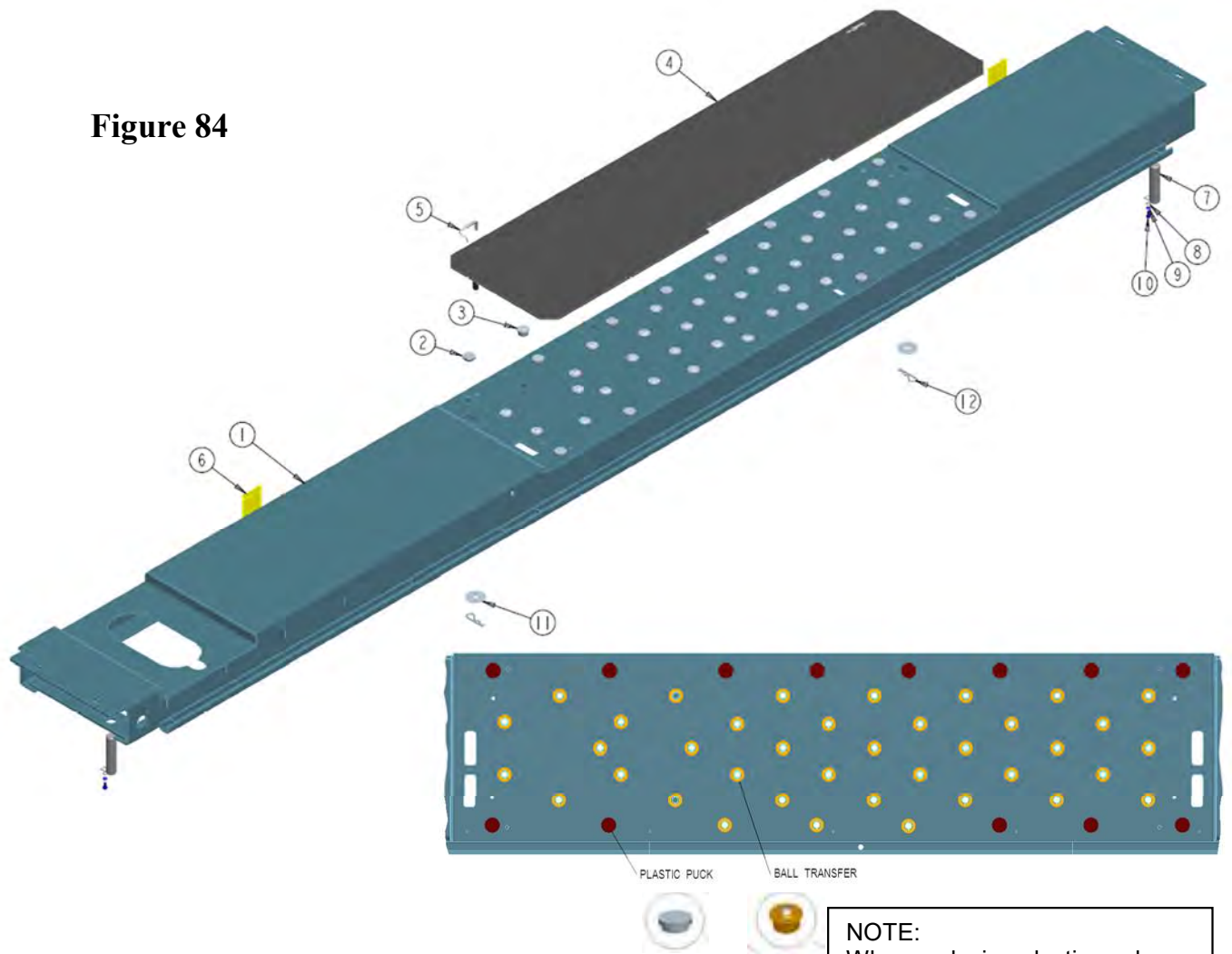
## PARTS LIST - LOCKS & LIGHTS (OPTIONAL)

### Deck Assembly, Left Side

Item#	Part #	Description	Qty.
1	4-1336	DECK WELDMENT, L.S.	1
2	6-3974	BALL TRANSFER	38
3	2-3035	SLIP PALTE WELD, L&L	1
4	2-0566	DECK SHEAVE PIN	4
5	1-0757	NYLON THRUST WASHER	5
6	1-3875	SHEAVE SPACER	2
7	4-1353	HYDRAULIC CYLINDER KIT	1
8	1-3876	SPACER, FRONT, RS, TOP	1
9	6-0295	FLAT WASHER, 5/16" I.D.	6
10	6-0674	LOCK WASHER, 5/16 I.D.	6
11	6-0293	HEX HEAD BOLT, 5/16-18UNC x 1" LG.	3
12	2-2866	CABLE FLANGE	1
13	6-3991	HEX NUT, 1-3/8 - 12 UNF	1
14	6-3992	HEX JAM NUT, 1-3/8 - 12 UNF	1
15	6-1763	CAPACITY DECAL, 12K OR 14K LB	1
16		MODEL NUMBER DECAL	1
17	6-2810	ALI GOLD DECAL	1
18	6-1637	SAFETY DECAL	1
19		ALI GOLD DECAL	1
20	1-3887	ANTI-ROTATION BAR, FORMED	1
21	KY089004	WARNING DECAL	2
22	1-3762	PLASTIC INSERT	15
23	2-2895	LOCKING UNIT, REVERSED	1
24	2-2713	LOCKING UNIT	1
25	6-4216	LED LIGHT BAR ASSY, LS	1
26	6-2971	FITTING, TEE, 1/4" POLYTUBE, PUSH-LOCK	6
27	6-4196	TREE MOUNT CABLE TIE, 8'LG.	13
28	6-0423	HEX BOLT, 5/16"-18UNC x 3/4" LG.	3
29	6-4215	RIVET 1/4 x 3/4	2
30	1-4103	RETAINING WASHER, L&L	2
31	6-0058	LOCK WASHER, 3/8"	2
32	6-0030	HEX BOLT, 3/8 UNC x 3/4 LG.	2
33	6-4103	LIGHT EXTENSION CABLE ASSEMBLY, RS	1
34	6-4104	LIGHT CABLE ASSEMBLY, LS	1
35	8-0372	POLYTUBE RED, 1/4"DIA x 0.038" WALL x 24FT	1
36	8-0373	POLYTUBE RED, 1/4"DIA x 0.038" WALL x 25FT	1
37	8-0141	POLYTUBE BLK, 1/4"DIA x 0.038" WALL x 19FT	1
38	8-0142	POLYTUBE RED, 3/8"DIA x 0.062" WALL x 13.5FT	1

## 10.9 PARTS LIST - DECK ASSEMBLY, RIGHT SIDE

**Figure 84**



**NOTE:**  
When replacing plastic pucks and ball transfers, please follow the layout above

Item#	Part #	Description	Qty.
1	4-1323	DECK WELDMENT, R.S.	1
2	1-3762	PLASTIC INSERT	13
3	6-3974	BALL TRANSFER	38
4	2-3035	SLIP PALTE WELD, L&L	1
5	2-0637	LOCKING PIN ASSEMBLY	2
6	KY089004	WARNING DECAL	2
7	2-0566	DECK SHEAVE PIN	2
8	6-0295	FLAT WASHER, 5/16" I.D.	2
9	6-0674	LOCK WASHER, 5/16 I.D.	2
10	6-0423	HEX BOLT, 5/16"-18UNC x 3/4" LG.	2
11	1-4104	RETAINING WASHER	2
12	HP29	3/16" HITCH PIN X 3 1/2' LG	2

## 10.10 EXPLODED VIEW - LOCKS & LIGHTS (OPTIONAL)

### Deck Assembly, Right Side

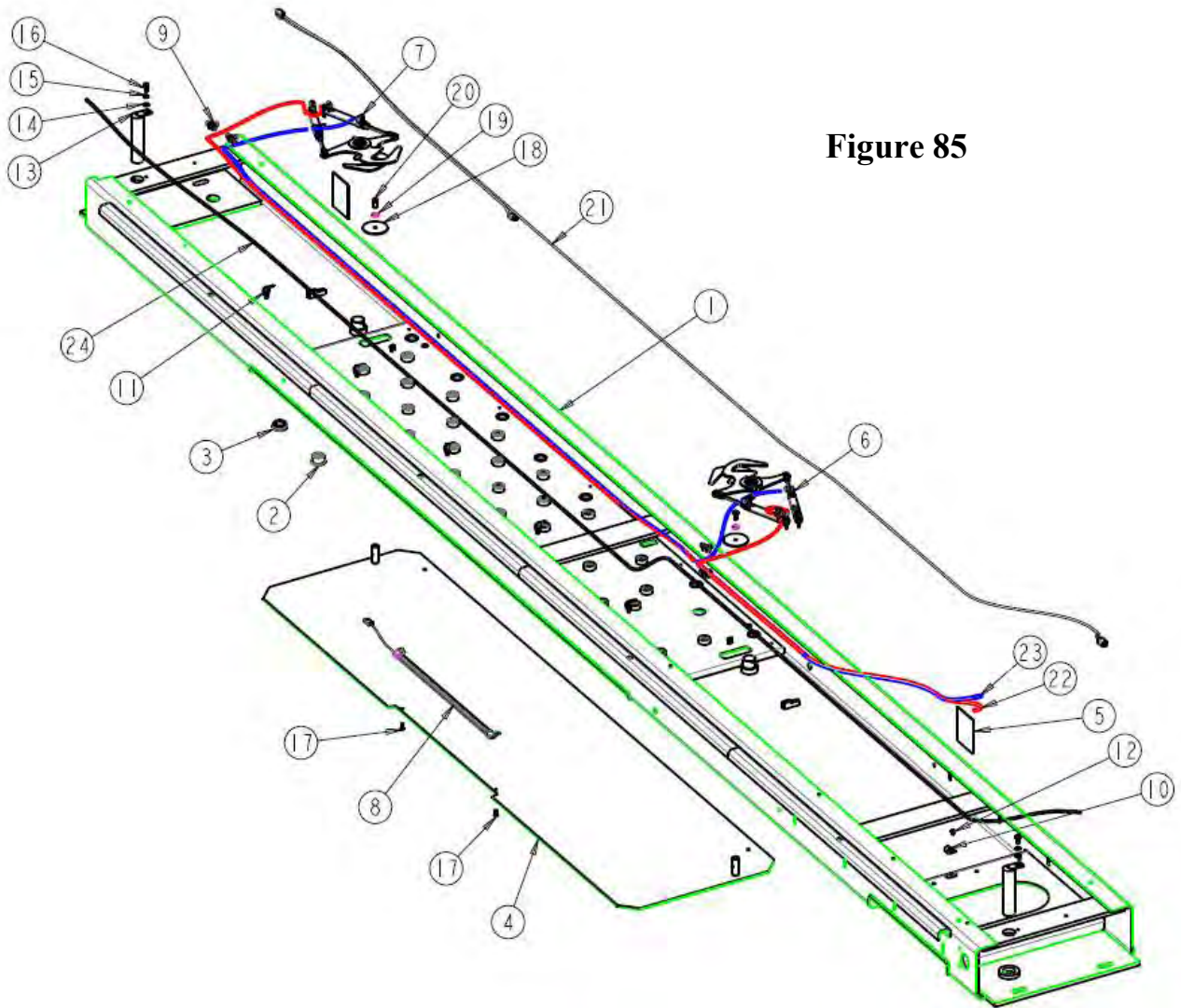
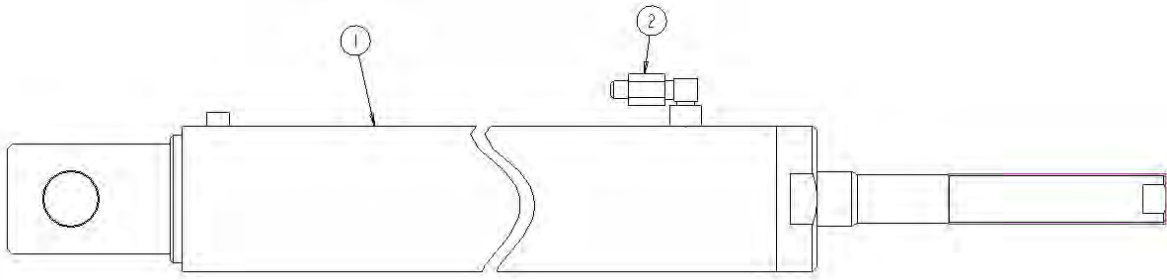


Figure 85

**PARTS LIST, LOCKS & LIGHTS (OPTIONAL)****Deck Assembly, Right Side**

<b>Item#</b>	<b>Part #</b>	<b>Description</b>	<b>Qty.</b>
1	4-1337	DECK WELDMENT, R.S.	1
2	6-3974	BALL TRANSFER	38
3	1-3762	PLASTIC INSERT	13
4	2-3035	SLIP PALTE WELD, L&L	1
5	KY089004	WARNING DECAL	2
6	2-2895	LOCKING UNIT, REVERSED	1
7	2-2713	LOCKING UNIT	1
8	6-4216	LED LIGHT BAR ASSY, LS	1
9	6-2971	FITTING, TEE, 1/4" POLYTUBE, PUSH-LOCK	4
10	6-1547	Tube Clamp, 5/8"	4
11	6-4196	TREE MOUNT CABLE TIE, 8'LG.	10
12	6-1353	ROUND HEAD SCREW, 1/4-20UNC X 3/8 LG	4
13	2-0566	DECK SHEAVE PIN	2
14	6-0295	FLAT WASHER, 5/16" I.D.	2
15	6-0674	LOCK WASHER, 5/16 I.D.	2
16	6-0423	HEX BOLT, 5/16"-18UNC x 3/4" LG.	2
17	6-4215	RIVET 1/4 x 3/4	2
18	1-4103	RETAINING WASHER, L&L	2
19	6-0058	LOCK WASHER, 3/8"	2
20	6-0030	HEX BOLT, 3/8 UNC x 3/4 LG.	2
21	6-4106	LIGHT CABLE ASSEMBLY, RS	1
22	8-0372	POLYTUBE RED, 1/4 OD x .038WALL x 20FT	1
23	8-0373	POLYTUBE BLUE, 1/4 OD x .038WALL x 20FT	1
24	8-0141	POLYTUBE BLACK, 1/4 OD x .038 WALL x 256"	1

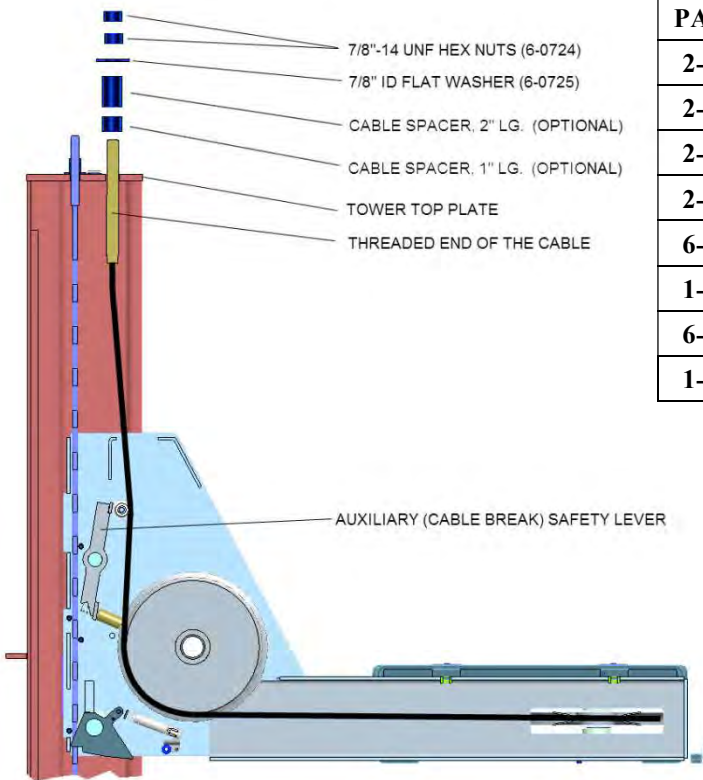
### 10.11 PARTS LIST – CYLINDER ASSEMBLY – P/N: 4-1353



Item#	Part #	Description	Qty.
1	4-1352	HYDRAULIC CYLINDER	1
2	6-2436	FLOW CONTROL 4P	1

**Figure 86**

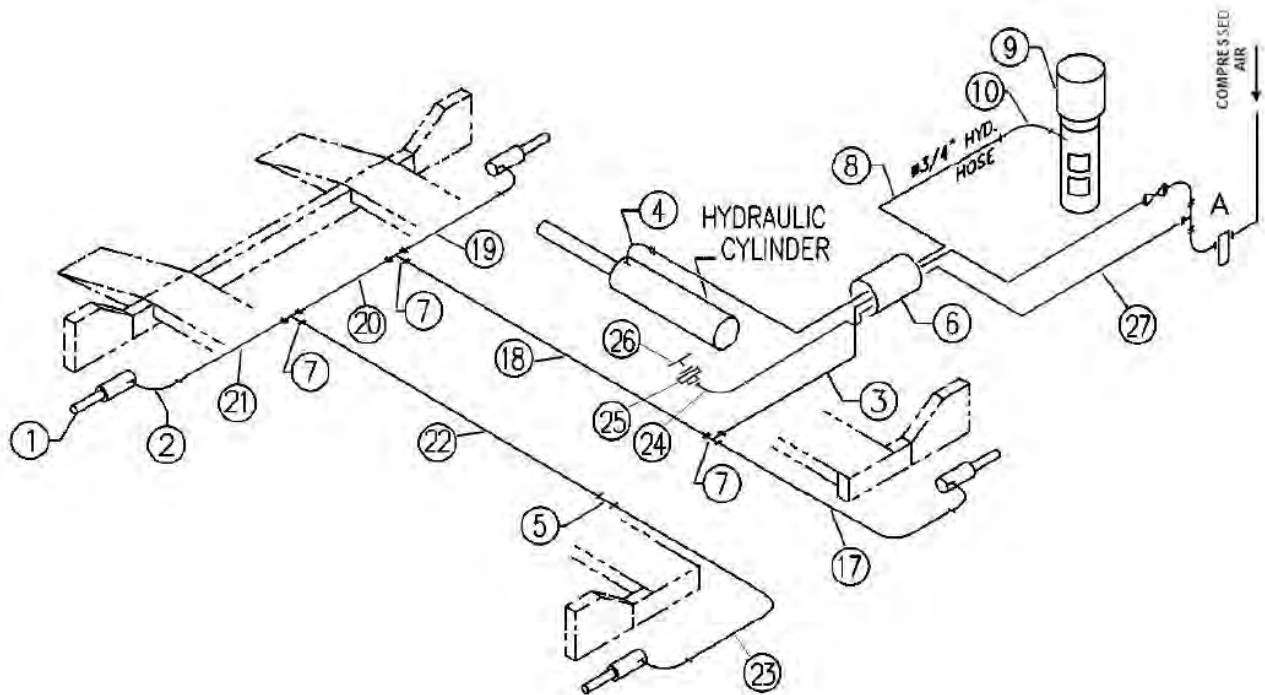
### 10.12 PARTS LIST - CABLE ROUTING



PART #	DESCRIPTION	QTY.
2-2914	CABLE ASSY. - FRONT LEFT	1
2-2917	CABLE ASSY. - FRONT RIGHT	1
2-2933	CABLE ASSY. - REAR LEFT	1
2-2916	CABLE ASSY. - REAR RIGHT	1
6-0724	HEX. NUT, 7/8\"-14 UNF, GR.8	8
1-0800	CABLE SPACER, 2\" LG (optional)	4
6-0725	FLAT WASHER, 7/8\" ID	4
1-0801	CABLE SPACER, 1\" LG (optional)	4

**Figure 87**

## 10.13 PARTS LIST - AIR AND HYDRAULICS



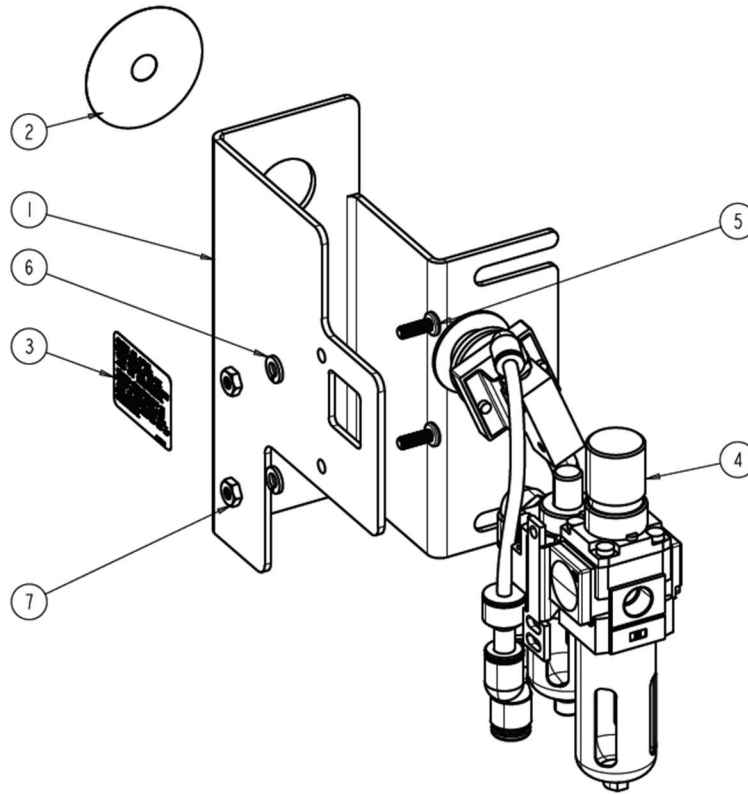
**Figure 88**

ITEM#	QTY.	DESCRIPTION	PART#
1	4	AIR CYLINDER, SAFETY RELEASE	6-3989
2	4	ELBOW, 90 DEG, 1/4" POLYTUBE TO #10-32 UNF	6-4040
3	77"	1/4" POLYTUBE, BLACK	8-0141
4	1	FLOW CONTROL	6-2436
5	1	FITTING, UNION, 1/4" POLYTUBE, PUSH-LOCK	6-3202
6	1	HOSE GUARD, 6ft.	1-4015
7	3	UNION, TEE, 1/4" POLYTUBE	6-2971
8	1	HYDRAULIC HOSE, 16FT	6-1692
9	1	POWER UNIT, 208-230V, 1PH	6-1398
10	1	ELBOW 90DEG, 9/16" SAE TO #6 JIC	6-0804
17	40"	1/4" POLYTUBE	8-0141
18	222"	1/4" POLYTUBE	8-0141
19	32"	1/4" POLYTUBE	8-0141
20	67"	1/4" POLYTUBE	8-0141
21	32"	1/4" POLYTUBE	8-0141
22	222"	1/4" POLYTUBE	8-0141
23	40"	1/4" POLYTUBE	8-0141
24	1	ELBOW, 90 DEG, 1/4" NPT TO 3/8" POLYTUBE	6-3010
25	1	TERMINAL BOLT, 3/4", SHORT	6-0713
26	1	TEE FITTING, 1/4" NPT, F	6-3896
27	182"	3/8" POLYTUBE, BLACK	8-0142



## 10.14 FILTER/REGULATOR/LUBRICATOR ASSEMBLY

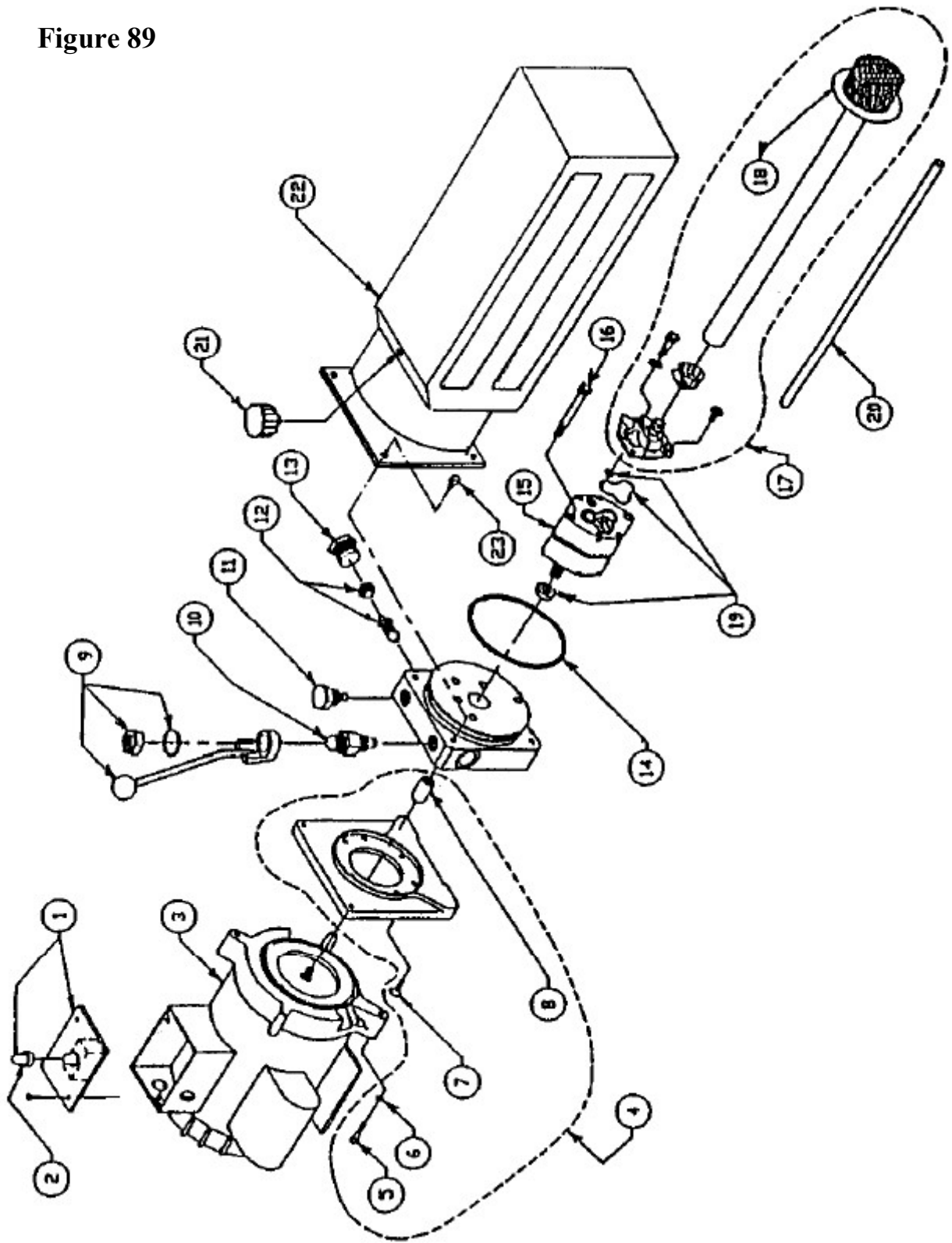
Complete Assembly: 2-3005



ITEM	QTY	DESCRIPTION	PART #
1	1	MOUNTING BRACKET, FRL	2-3022
2	1	DECAL, SAFETY RELEASE	6-3558
3	1	DECAL, OIL LEVER	6-3696
4	1	FRL ASSEMBLY W/ RELEASE BUTTON, contains:	2-3021
	1	FILTER/REGULATOR/LUBRICATOR ASS'Y	6-4142_FM
	1	90 DEG. ELBOW, 1/4"NPT M - 3/8" POLY	6-3010
	1	AIR VALVE & PUSHBUTTON	6-1777
	1	SWIVEL ELBOW, 1/8"NPT M - 1/4" POLY	6-0709
	1	PUSHLOCK UNION, 3/8" POLY	6-4214
	1	REDUCER, 3/8" STEM - 1/4" POLY	6-3731
	1	PUSHLOCK UNION, 1/4" POLY	6-3202
	1	ADAPTER, 1/8" NPT M - 1/4" POLY	6-0708
5	2	PHMS, #12-24 X 5/8" LG	6-4145
6	2	LOCK WASHER, 1/4" ID	6-0056
7	2	HEX NUT, #12-24	6-4146

# 10.15 PARTS LIST - POWER PACK

Figure 89



#6-1398, 208-230V/1PH/60Hz

ITEM	QTY.	DESCRIPTION	PART#
1	1	MICROSWITCH AND WIRING ASSEMBLY	6-4257
2	1	MICROSWITCH BOOT	6-1084
3	1	MOTOR, 230V AC, 1 PHASE, 60 HERTZ, 3HP	6-1959
	1	MOTOR, 230V AC, 3 PHASE, 60 HERTZ	6-1079
4	1	MOTOR ADAPTER KIT	0-0197
5	4	SOCKET HD.CAP SCW. 1/4"-20UNC X 1 5/8"LG.	6-1085
6	4	LOCK WASHER, 1/4" I.D.	6-0056
7	4	ALLEN FLAT HD.SCW. 1/4"-20UNC X 3/4"LG.	6-1086
8	1	COUPLING	6-0774
9	1	RELEASE BRACKET & HANDLE ASSEMBLY	6-0776
10	1	VALVE CARTRIDGE RELEASE	6-0880
11	1	VALVE CARTRIDGE CHECK	6-1087
12	1	FIXED RELIEF VALVE ASSEMBLY (RV 23)	6-1323
13	1	RELIEF VALVE CAP	6-1089
14	1	RESERVOIR "O" RING	6-0875
15	1	PUMP ASSEMBLY, 2.5CC/REV	6-1958
16	2	PUMP MOUNTING BOLT	6-1090
17	1	INLET PLUMBING KIT	0-0198
18	1	INLET HOSE / FILTER ASSEMBLY	6-0786
19	1	PUMP "O" RING KIT	0-0199
20	1	RETURN TUBE	6-0783
21	1	BREATHER FILLER CAP	6-0784
22	1	RESERVOIR	6-0785
23	4	RESERVOIR SCREW	6-1091

# 10.16 EXPLODED VIEW - LOCKS & LIGHTS (OPTIONAL)

## Control Box #6-4279

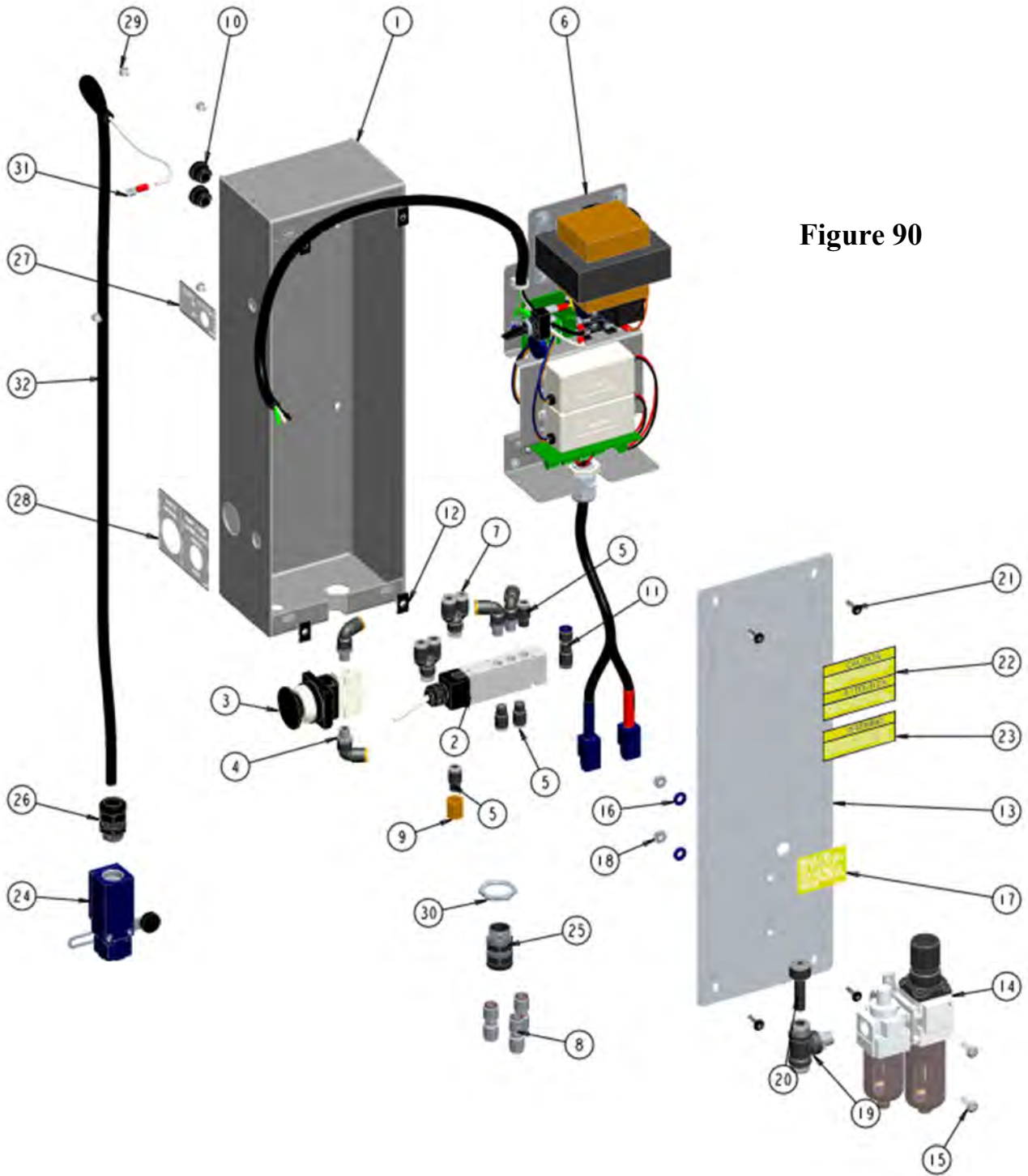


Figure 90

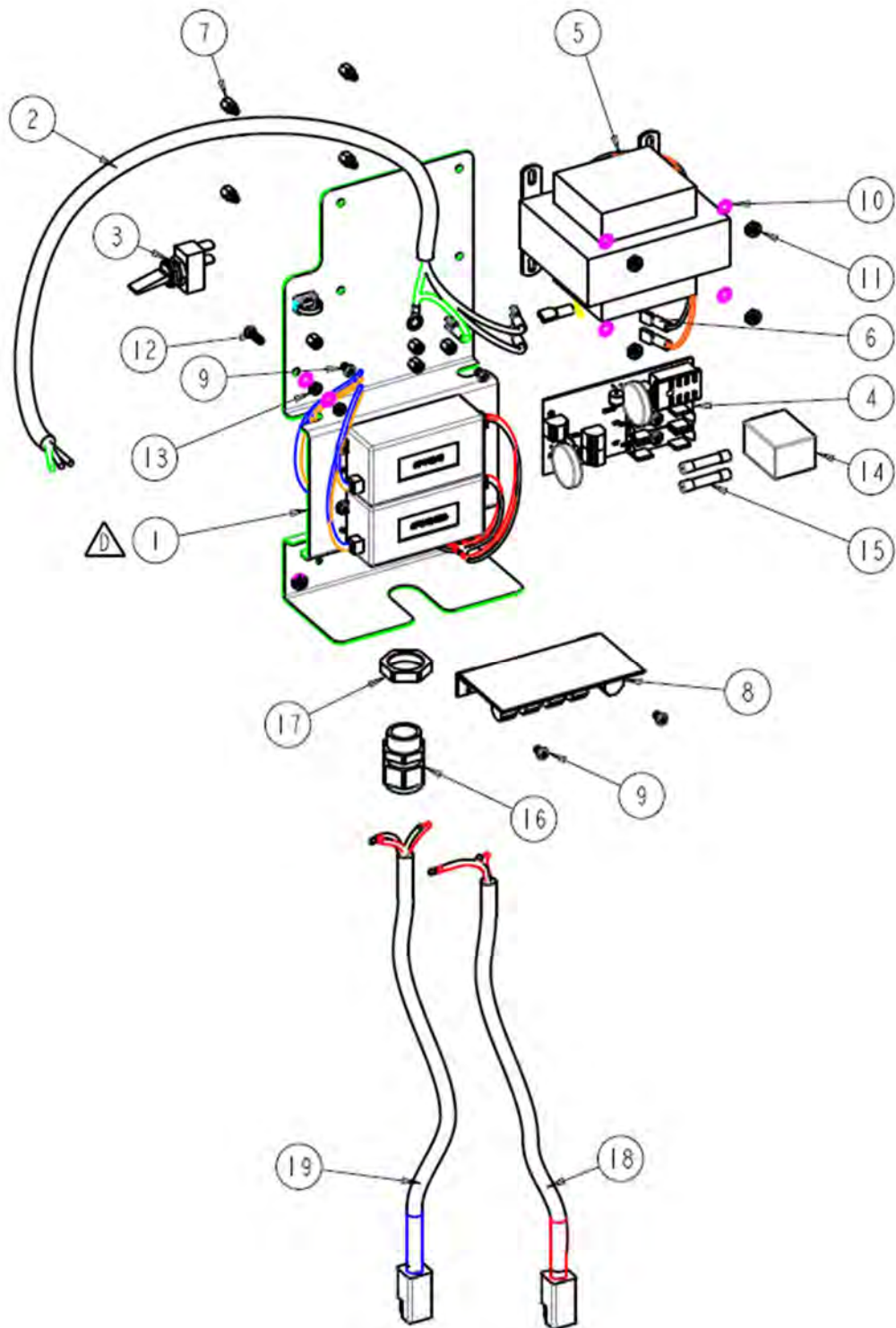
## PARTS LIST, LOCKS & LIGHTS (OPTIONAL)

### Control Box # 6-4279

Item#	Part #	Description	Qty.
1	6-4280	ENCLOSURE WELDMENT	1
2	6-3905	5 PORT MECHANICAL VALVE	1
3	6-4275	SAFETY RELEASE PUSH BUTTON ASS'Y	1
4	6-0709	SWIVEL ELBOW, 1/4" NYLON TUBE, 1/8" NPT	4
5	6-0708	ADAPTER, 1/8" NPT -1/4" POLY	4
6	6-4281	LED POWER SUPPLY FRAME ASSY	1
7	6-3729	UNION Y, 1/4" POLY	2
8	6-3202	FITTING, UNION, 1/4" PUSH-LOCK	3
9	6-3977	BREATHER VENT - NPT FEMALE	1
10	6-4120	STRAIN RELIEF BUSHING	2
11	6-3952	CHECK VALVE, 1/4" POLY	1
12	6-3074	U-TYPE FASTENER	4
13	6-4278	COVER, ENSLOSURE	1
14	6-4142	FILTER/REGULATOR/LUBRICATOR	1
15	6-4145	PHMS, #12-24 X 5/8 LG. PLATED	2
16	6-0056	LOCK WASHER, 1/4" I.D.	2
17	6-3696	DECAL, OIL LEVEL	1
18	6-4146	HEX NUT, #12-24 PLATED	2
19	6-3730	SWIVEL TEE 3/8 POLY - 1/4 NPT M	1
20	6-3731	REDUCER, 3/8" STEM - 1/4" POLY	1
21	6-3075	SCREW, 10-24 X 5/8 PHILLIPS	4
22	6-3873	ELECTRIC SHOCK, NO SERVICING	1
23	6-3872	ARCING AND SPARKING, PENDANT	1
24	6-4116	ADJ. ROLLER LEVER SWITCH	1
25	6-3583	STRAIN RELIEF 1/2"NPT	1
26	6-4119	STRAIN RELIEF, M20x1.5	1
27	6-4130	DECAL, LIGHT SYSTEM	1
28	6-4285	DECAL, RSP & SAFETY LOCK	1
29	6-4287	PH PHILIPS MACH. SCREW, #8-32 X 1/4"LG	4
30	6-1610	CONDUIT LOCKNUT 1/2"	1
31	6-3577	QUICK SLIDE DISCONNECT	1
32	8-0306	ELECTRICAL CABLE,18/3 SJOOW, CTS	49"

## 10.17 POWER SUPPLY FRAME ASSEMBLY (OPTIONAL)

Item #6 in Figure 90.



**PARTS LIST, POWER SUPPLY FRAME ASSEMBLY (OPTIONAL)**

<b>Item#</b>	<b>Part #</b>	<b>Description</b>	<b>Qty.</b>
1	6-4297	LED POWER SUPPLY AND FRAME ASSY	1
2	6-4296	POWER CABLE ASSY, 18/3 W/ CONNECTORS	1
3	6-4108	TOGGLE SWITCH	1
4	6-4298	SURGE PROTECT MODULE (SPM)	1
5	6-2126	COIL 24V	1
6	6-3577	QUICK SLIDE DISCONNECT	3
7	6-4284	STANDOFF MALE-FEMALE, #8-32, 1/4"	4
8	6-4264	TRANSIENT PORTECTION MODULE (TPM)	1
9	6-3593	#6-32x1/4 PH PAN HD T/C T-F ZC	4
10	6-3465	LOCKWASHER, INTERNAL #8	6
11	6-1095	HEX NUT, #8-32UNC	4
12	6-1466	PAN HD MACH. SCREW 6-32 X 1/2" LG	1
13	6-3170	HEX NUT, #6-32	4
14	6-4260	POWER RELAY, 24VAC DPDT	1
15	6-4261	FUSE, 250V, 2AMP, 6X32mm	2
16	6-4267	CABLE GLAND, 1/2 NPT	1
17	6-4266	CABLE NUT, 1/2" NPT	1
18	6-4282	4-POLE CABLE ASSEMBLY - RED	1
19	6-4283	4-POLE CABLE ASSEMBLY - BLUE	1

## 10.18 EXPLODED VIEW - LOCKS & LIGHTS (OPTIONAL)

### Front Turnplate Assembly

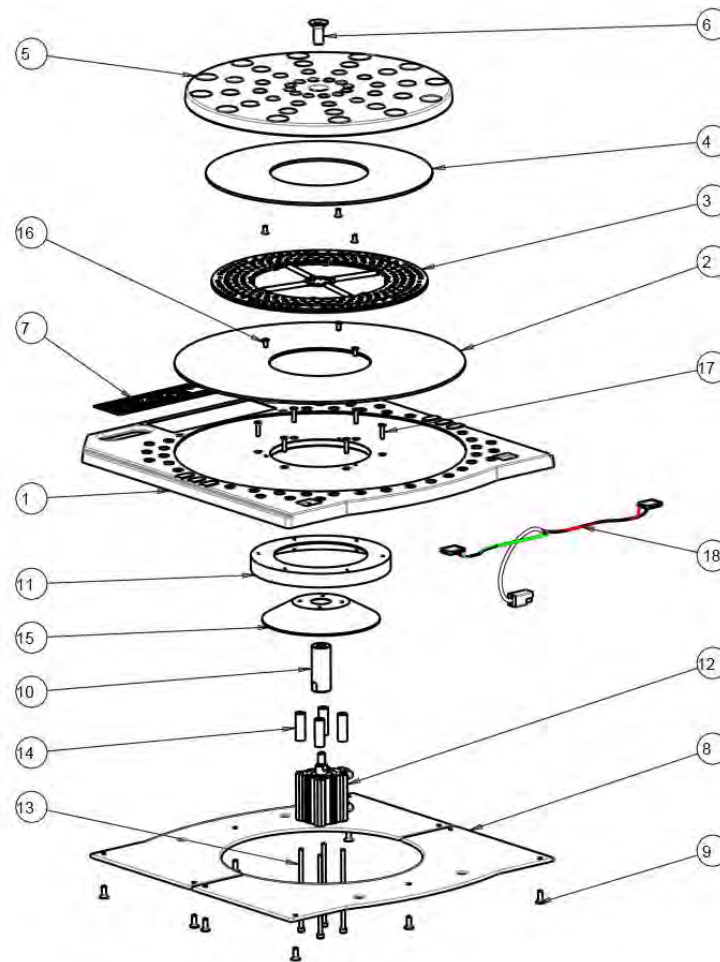


Figure 91

Item#	Part #	Description	Qty.
1	2-2932	TURNPLATE ASSEMBLY (COMPLETE)	1
2	EAM0047J58A	BOTTOM WEAR PLATE	1
3	EAA0333J59A	BALL PLATE ASM.	1
4	EAM0047J57A	WEAR PLATE - TOP	1
5	EAM0047J60A	TOP - TT, MACH.	1
6	6-3956	SCREW - FHSC, M14 X 30mm	1
7	1-3719	LABEL, TT, LOCKING	1
8	EAM0047J52A	PAD - TT	2
9	6-3955	FHMS, PHIL SCREW - M6 X 16mm	10
10	1-3678	STUB SHAFT	1
11	2-2711	CENTERING RING	1
12	6-3899	LOCKING CYLINDER ASSEMBLY	1
13	6-3902	SHCS, M5X0.8 X 120 LG	4
14	1-3677	CYLINDER STAND-OFF	4
15	2-2709	CENTERING CONE	1
16	6-3954	SCREW - FHMS M5 x .8, 10mm	6
17	6-3904	FHCS, #10-32 UNF X 3/4, STAINLESS STEEL	6
18	6-4101	LED LIGHT & CABLE ASS'Y	1



