

HOFMANN

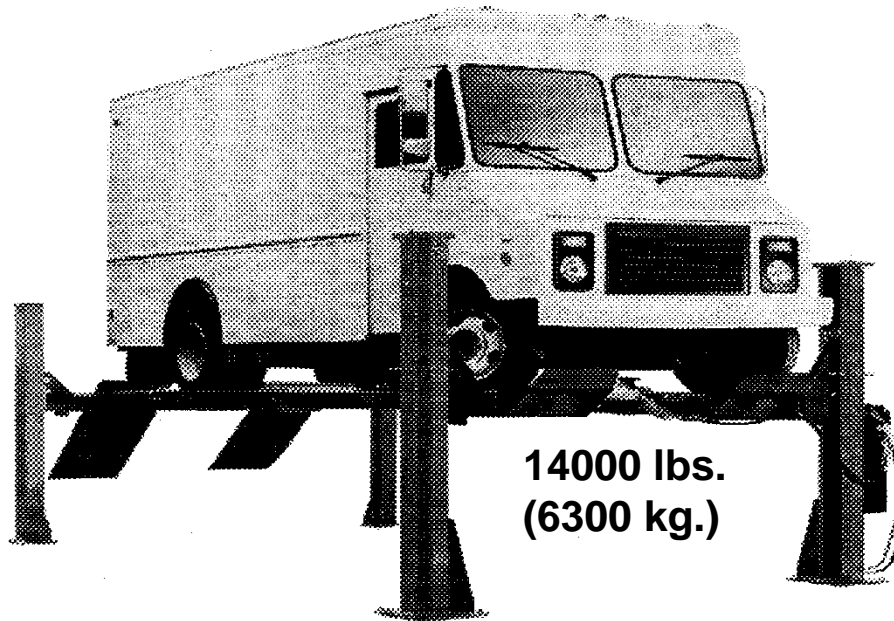

4-POST MODEL FPA14210 FPA14210R



14000 lbs.
(6300 kg.)

INSTALLATION AND OPERATION MANUAL

**READ THIS INSTRUCTION MANUAL THOROUGHLY BEFORE
INSTALLING, OPERATING, SERVICING OR MAINTAINING THE
LIFT. SAVE THIS MANUAL.**

DEC 2011 REV.- 6-2411

HOFMANN
USA

309 Exchange Avenue • Conway, AR 72032
(800) 251-4500 • (501) 505-2662
Fax (501) 450-2085 • www.hofmann-usa.com

HOFMANN
Canada

6500 Millcreek Drive • Mississauga, ONT L5N 2W6
(800) 267-2185
Fax (905) 821-2073 • www.hofmann.ca

THE FOLLOWING APPLIES TO ALL LIFTS

IMPORTANT SAFETY INSTRUCTIONS

1. When using this lift, basic safety precautions should always be followed, including the following:
2. Read all instructions in this manual and on the lift thoroughly before installing, operating, servicing or maintaining the lift.
3. Inspect lift daily. Do not operate if it malfunctions or problems have been encountered.
4. Never attempt to overload the lift. The manufacturer's rated capacity is shown on the identification label on the power side column. Do not override the operating controls or the warranty will be void.
5. Only trained and authorized personnel should operate the lift. Do not allow customers or bystanders to operate the lift or be in the lift area.
6. **Caution! Never work under the lift unless the mechanical safety locks are engaged.**
7. Always keep the lift area free of obstruction and debris. Grease and oil spills should always be cleaned up immediately.
8. Never raise vehicle with passengers inside.
9. Before lowering check area for any obstructions
10. To protect against the risk of fire, do not operate lift in the vicinity of open containers of flammable liquids.
11. Adequate ventilation should be provided when working on internal combustion engines.
12. Do not remove hydraulic fittings while under pressure.
13. Do not raise or lower the lift with the vehicle on the Jacking Beam.

SAVE THESE INSTRUCTIONS

+ 070126-Quadra-WLSIA01

SAFETY INSTRUCTIONS

If attachments, accessories or configuration modifying components that are located in the load path, affect operation of the lift, affect the lift electrical listing or affect intended vehicle accommodation are used on this lift and, if they are not certified for use on this lift, then the certification of this lift shall become null and void. Contact the participant for information pertaining to certified attachments, accessories or configuration modifying components.

www.autolift.org

©2007 by ALI, Inc.

ALI / WLSIA01

TABLE OF CONTENTS**PAGE**

1.0	GENERAL SPECIFICATIONS	4
2.0	TOOLS REQUIRED FOR INSTALLATION.....	5
3.0	CONTENTS.....	6
4.0	INSTALLATION INSTRUCTIONS.....	8
4.1	Chalk Line layout.....	9
4.2	Front And Rear Crossmember Assemblies.....	10
4.3	Front Cable Installation.....	11
4.4	Anchor Installation – Front Posts	13
4.5	Deck & Crossmember Installation.....	15
4.6	Cable Installation	15
4.7	Power Pack Installation.....	17
4.8	Hydraulic Installation.....	18
4.9	Electrical Connections	18
4.10	Air Installations.....	20
4.11	Safety Retaining System.....	21
4.12	Anchor Installation – Rear Posts.....	22
4.13	Leveling Procedure - Cables.....	22
4.14	Leveling Procedure – Safety Ladders	23
4.15	Final Check Of Assembled Lift	24
4.16	Operation Test With Vehicle	25
5.0	SAFETY AND OPERATING INSTRUCTIONS	26
6.0	SAFETY AWARENESS	27
7.0	RECOMMENDED MAINTENANCE GUIDELINES	28
8.0	PARTS MANUAL.....	30
8.1	Lift Assembly.....	30
8.2	Lift Parts List	31
8.3	Hydraulic And Air Kits Assembly.....	33
8.4	Hydraulic And Air Kits Assembly Parts List	34
8.5	Cable Routing Diagram	35
8.6	Cable Routing Parts List	36
8.7	Safety Retainer Bracket	37
8.8	Power Pack.....	38
8.9	Power Pack Parts List	39
9.0	AVAILABLE ACCESSORIES	41

1.0 GENERAL SPECIFICATIONS

Maximum Capacity:

Overall Length:

Overall Width:

Down Position Height:

Maximum Lifting Height:

Maximum Wheel Base:

Rise Time:

Power Requirements:

Air Requirements:

Shipping Weight:

14000 lbs.	6350 kg
304 9/16"	7712mm
148 1/4"	3759mm
10"	254mm
71"	1803mm
210"	5334mm
65 Seconds	
230 Volts AC, 1Ph., 20 Amp, 60Hz.	
90 – 120 psi Shop Air	
5030 lbs.	2286 kg

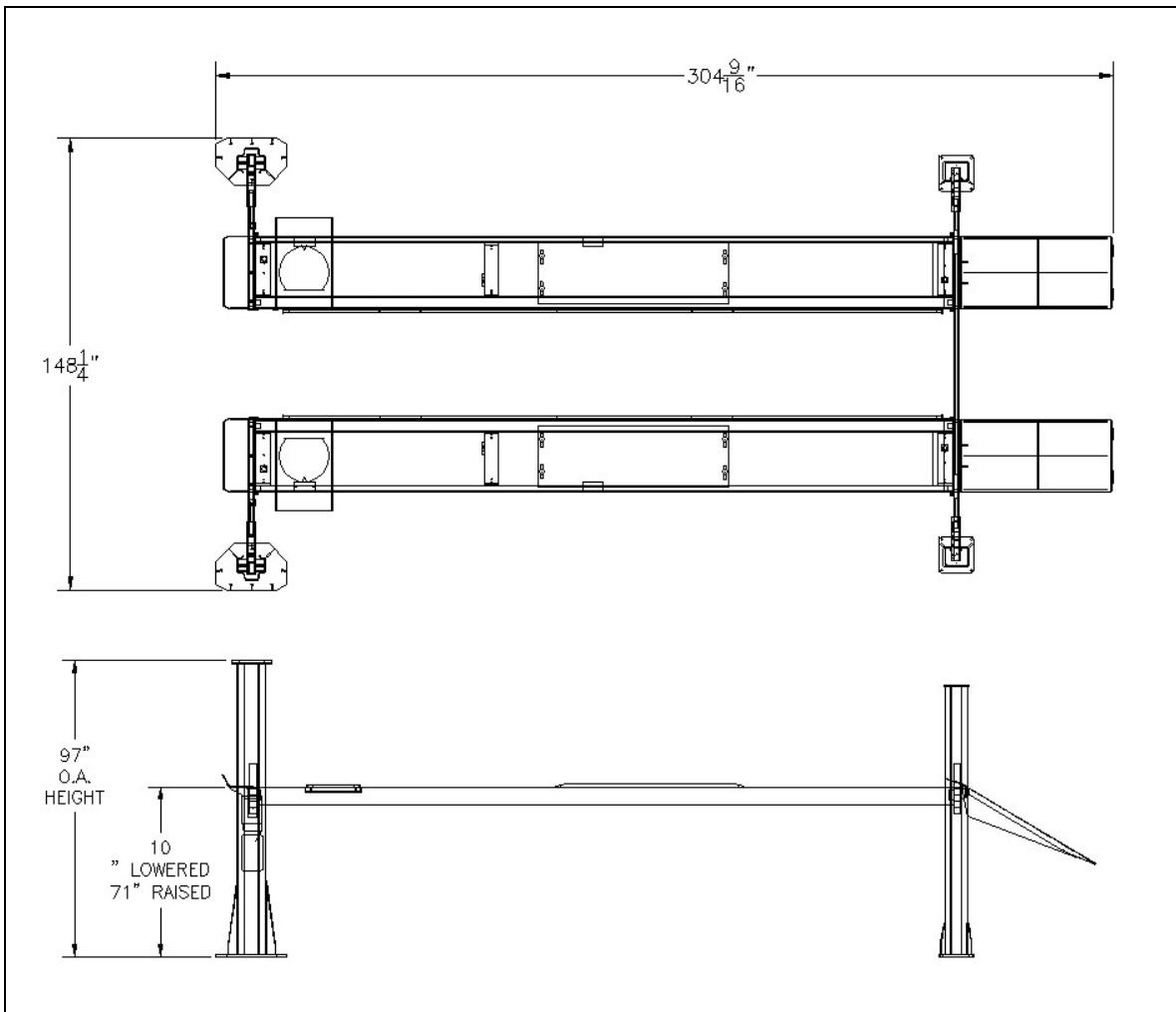

**CHECK CONTENTS OF ACCESSORY BOX WITH THE PACKING LIST
ENCLOSED**



ATTENTION! This lift is intended for indoor installation only. It is prohibited to install this product outdoors. Operating environment temperature range should be 41 – 104 °F (5 – 40 °C). Failure to adhere will result in decertification, loss of warranty, and possible damage to the equipment.

2.0 TOOLS REQUIRED FOR INSTALLATION

ROTARY HAMMER DRILL
3/4" CONCRETE DRILL BIT
SOCKET FOR TIGHTENING ANCHORS
4' LEVEL
HAMMER (for anchor installation)
PRY BAR (for shim installation)
CHALK LINE (lift location)
FISH (mechanics wire to feed cable through crossmember assembly)
TAPE MEASURE
ELECTRICAL TAPE
STEP LADDER (adjusting cables and/or safety ladder in posts)
SIDE CUTTERS (for cutting shipping straps)
BAR (4' long)
4 WORK STANDS (set up)
STANDARD SOCKETS AND WRENCHES

3.0 CONTENTS

The 14,000 lb. lift is packaged to protect it from any damage that may occur in shipping. The two deck assemblies and crossmembers are packaged together with the accessory boxes strapped to them.

Main Structural Components:

- 1 - Left Side Deck Assembly (complete with hydraulic cylinder)
- 1 - Right Side Deck Assembly
- 2 - Front Crossmembers Assemblies (with air cylinder release locks and sheaves)
- 1 - Rear Crossmember Assembly (with air cylinder release locks and sheaves)

Accessory Box Components

Box 1 Contents:

- 1 - Power Post (with safety ladder)
- 3 - Post (with safety ladder)

Box 2 Contents:

- 1 - Power Pack Assembly complete with Flow Control
- 2 - Approach Ramps
- 7 - Sheave Assemblies
- 1 - Set of Cables (set contains 4 cables with nuts and spacers)
- 6 - Sheave Spacers (different sizes)
- 2 - Front Wheel Stops
- 2 - Ramp Pins
- 4 - Deck Sheave Pins
- 1 - Air Kit (with 1/4" and 3/8" polytube and fittings)
- 1 - Hydraulic Hose (with fittings)
- 1 - Hose Guard
- 4 - Sheave Covers
- 3 - Cable Tie (for attachment of hydraulic hose to cylinder)
- 2 - Recoiled Air Hoses 12' long
- 1 - Coupler 1/4" NPT
- 1 - Package of Hardware (with its own packaging list)
- 1 - Owner's manual
- 1 - ALI manual "Lifting It Right"
- 1 - Automotive Lift Safety Tips
- 1 - Automotive Lift, Operation, Inspection and Maintenance manual
- 1 - "ALI" Quick Reference Guide

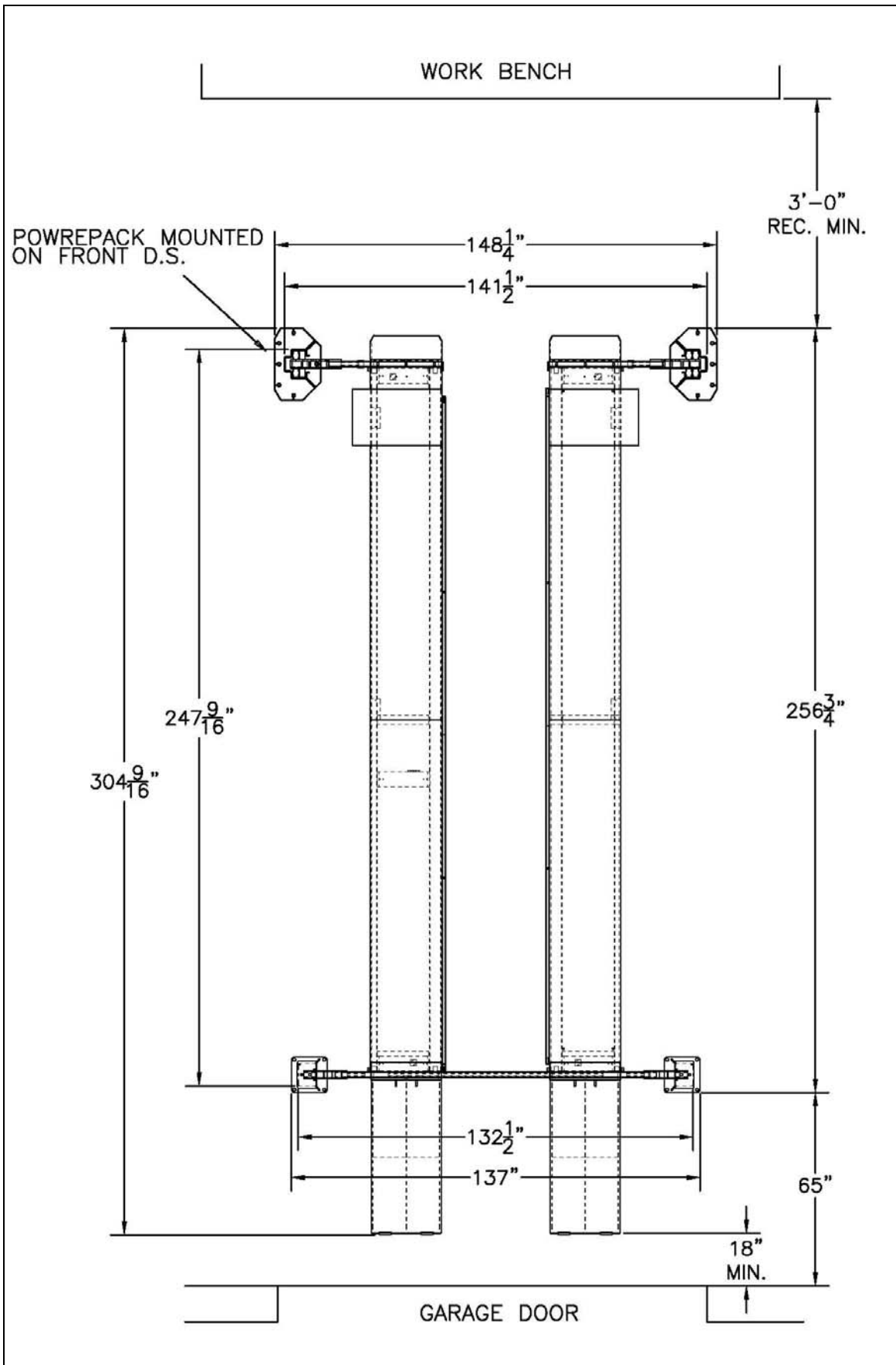

Figure 1. General lift specifications

4.0 INSTALLATION INSTRUCTIONS

PLEASE TAKE THE TIME TO READ THESE INSTRUCTIONS COMPLETELY. A QUICK CHECK OF THE CONTENTS OF THE ACCESSORY BOX WOULD ALSO DECREASE THE OVERALL TIME OF THE INSTALLATION.

- Gather the tools and materials required for the installation.
- Select the location best suited for your lift.

NOTE: In determining lift area check for the following:

- Ease of driving a vehicle on and off the lift.
- Overhead obstructions, low ceiling height, overhead doors, overhead heaters etc.
- Floor obstructions, uneven floor in lift area, floor drains, workbenches, electrical wiring in floor, etc.
- **IMPORTANT:** It is the user's responsibility to provide a satisfactory installation area for the lift. Lifts should only be installed on level concrete floors with a minimum thickness of five (5) inches or 130mm. Concrete must have a minimum strength of 4000 psi or 30 MPa and should be aged thirty (30) days prior to installation. Please consult the architect, contractor or engineer if doubt exists as to the strength and feasibility of the floor to enable proper lift installation and operation.
- It is the user's responsibility to provide all wiring for electrical hook-up prior to installation and to insure that the electrical installation conforms to local building codes. Where required, it is the user's responsibility to provide an electrical isolation switch located in close proximity to the lift that will enable emergency stop capability and isolate electrical power from the lift for any servicing requirements.

Recommended clearance around the lift is three (3) feet. Ensure clearance conforms to local building and fire codes.

Recommended overhead clearance is a minimum twelve (12) foot ceiling providing 6 feet for the maximum lift height and 6 feet for the supported vehicle. For vehicles taller than 6 feet it is recommended that the user provides additional overhead clearance or a shut off mechanism to stop the lift from raising the vehicle too high.

- An outline matching the dimensions shown in Figure 2 will need to be marked on the floor. Refer to Figure 2 for outline dimensions. Refer to General Lift Specifications for overall lift dimensions. Figure 1.

4.1 CHALK LINE LAYOUT

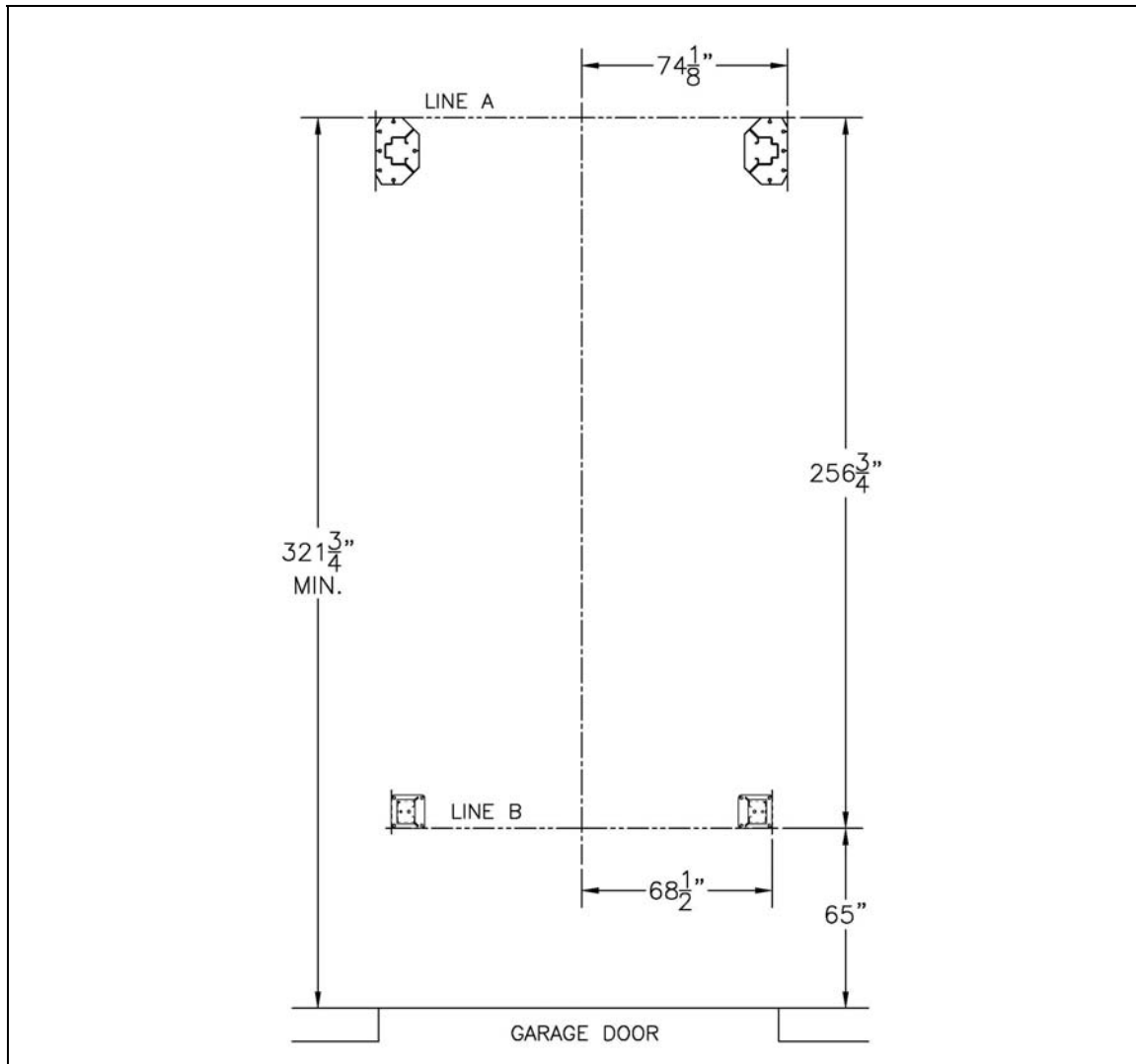

Figure 2. Chalk line layout

- **Refer to Figure 2.** Make a chalk line parallel to the doorway at least 321-3/4" in from the doorway. Call this line "A". This will be the location for the front face of the front posts baseplate.
- Determine the center of the doorway and bay. Make a centerline to intersect with line "A". Measure from the centerline along line "A", 74-1/8" in both directions. This will be the location of the front posts.
- Make a chalk line parallel to line "A" by measuring back 256-3/4", and call this line "B". This will be the location for the back baseplate face of the rear posts.
- Measure from the centerline along line "B" 68-1/2" in both directions. This will be the location of the outside baseplate face of the rear posts. Position work stands inside of line "A" and "B" of outline, to support the front and rear of each deck assembly.

4.2 FRONT AND REAR CROSSMEMBER ASSEMBLIES

IMPORTANT

NOTE: To determine the front, rear, left side and right side of the decks, check the following:

- The left deck has the hydraulic cylinder mounted to its underside. The rear of the decks have approach ramp brackets to install the drive on approach ramps. The work steps, attached to the turn plate pocket cutouts will face towards the front outside of the lift.

NOTE: To identify front and rear crossmembers, refer to Figure 3.

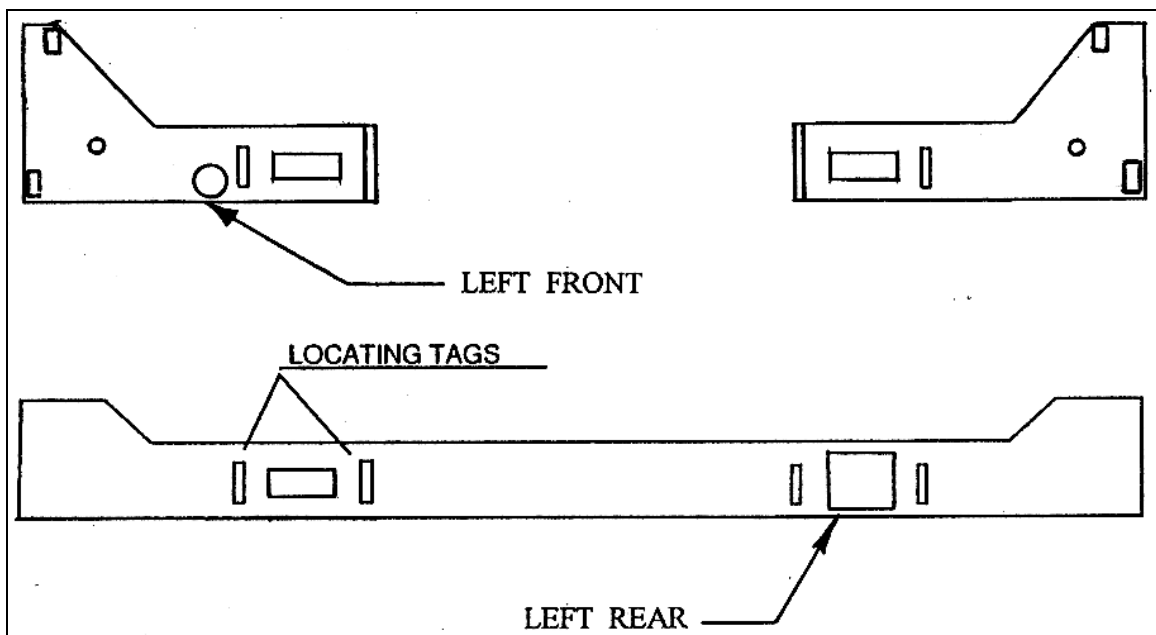

Figure 3. Front and rear crossmember assembly

- The crossmember assemblies are fully assembled and the PULLEYS DO NOT NEED TO BE REMOVED FOR CABLE INSTALLATION.
- Locate the front left tower. This tower has the mounting plate for the power pack. The rear towers are identical to each other.

4.3 FRONT CABLE INSTALLATION

- Locate cables and set out on the floor. Check the part numbers located on each stud of each cable. (Refer to Section 8.5, CABLE ROUTING DIAGRAM)

	Description	Part #
Cable #1	Cable Assembly, 404.5” Lg.	2-1504
Cable #2	Cable Assembly, 157.75” Lg.	2-1505
Cable #3	Cable Assembly, 13.75” Lg.	2-1506
Cable #4	Cable Assembly, 459.5 Lg.	2-1507

NOTE: THE PULLEYS (SHEAVES) ON THE CROSSMEMBERS DO NOT HAVE TO BE REMOVED FOR CABLE INSTALLATION. A 3/8" - 16 UNC × 3" LG. HEX HEAD BOLT MUST BE REMOVED FROM THE CROSSMEMBERS TO ALLOW CABLE INSTALLATION AROUND THE PULLEYS. THIS 3/8" - 16 UNC × 3" LG. HEX HEAD BOLT MUST BE RE-INSTALLED AFTER THE CABLES ARE ROUTED THROUGH THE CROSSMEMBER ASSEMBLIES.

WARNING!!!

DO NOT APPLY LUBRICANT TO SHEAVE ASSEMBLY. FIBRE BUSHING IS PTFE SELF-LUBRICATING. THE ADDITION OF LUBRICANT WILL SHORTEN THE LIFE OF THE FIBRE BUSHING.

- At this point only the front cables will be routed for ease of installation.
- Before beginning cable routing, refer to Figure 4, Cable and Routing Diagram.
- Begin routing cable # 4 (part # 2-1507) starting at the very top of the right side of the front crossmember assembly using the non threaded end of the cable as shown in Figure 4. Place the non-threaded end of the cable at the opening of the front-right crossmember.
- Route cable # 1 (part # 2-1504) starting at the very top of the left side of the front crossmember assembly using the non-threaded end of the cable as described in Figure 4. Place the non-threaded end of the cable at the opening of the front-left crossmember.

NOTE: WHEN SLIDING FRONT CROSSMEMBERS INTO TOWERS, TILT CROSSMEMBER TOWARDS TOP OF TOWER TO PREVENT SAFETIES FROM ENGAGING.

- Remove the top plate off both the front towers, and install the front crossmembers by laying the front towers on the floor. Insert the slider blocks into the front towers through the opening on the top of the tower. Slide the crossmember down until it reaches the bottom of the tower.
- Bolt the top plate on top of the towers using five 1/2"-13UNC hex hd. bolts, nuts, flatwashers, and lockwashers.
- Stand front towers up and position as per bay layout. See Figure 1 and Figure 2.

- Raise front crossmember to the sixth (6th) safetylock and place axle stand under beam to support it. Work stands should be placed as close as possible to the towers.
- Make sure crossmembers are inline and shim vertically.

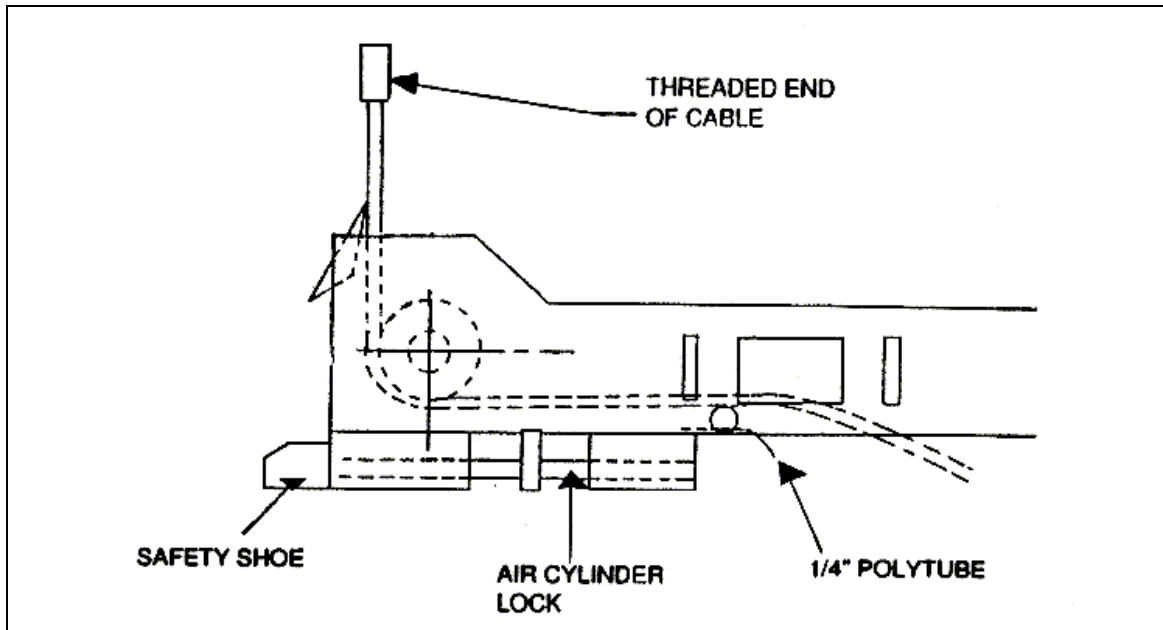

Figure 4. Typical cable routing in crossmember assembly

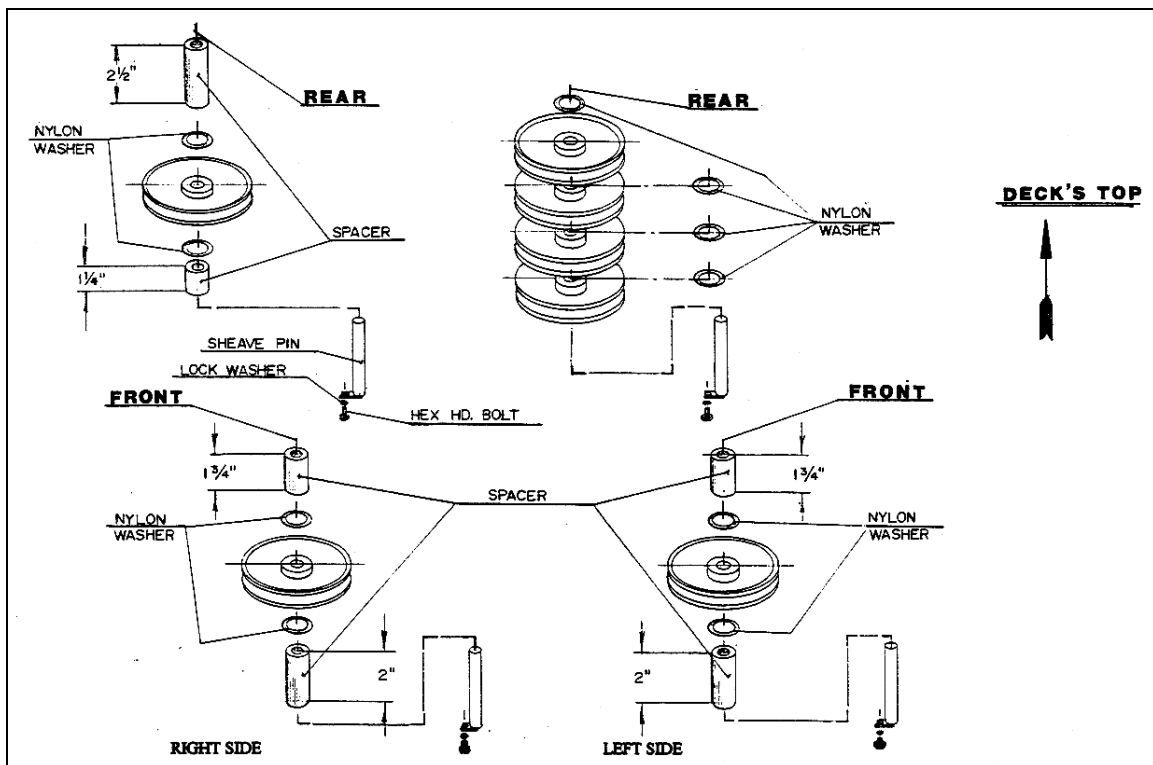

Figure 5. Sheaves installation

4.4 ANCHOR INSTALLATION – FRONT POSTS

1. Refer to Figure 6 while reading through these instructions.

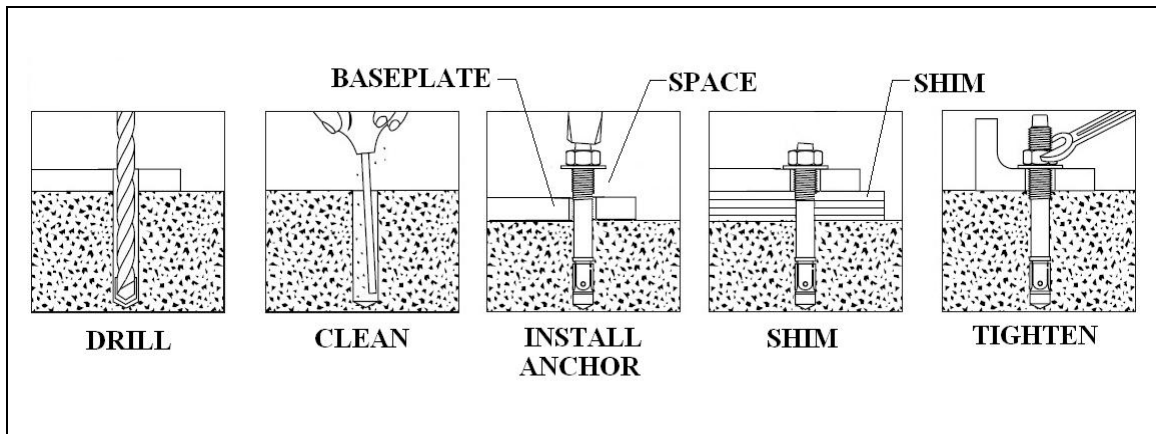

Figure 6. Anchor installation

2. Ensure that the lift is fully supported by the cables and is at a level just above the work stands.
3. Prior to installing anchors, assemble the nut and washer onto anchors. A minimum of six threads must be visible below the surface of the nut.
4. Using a 3/4" concrete drill bit and rotary hammer drill, drill through the concrete floor in the anchor holes positioned on the base of each post. (In case longer anchors are required, supplied anchors can be hammered through concrete).
5. Using a hammer, drive each anchor into floor leaving space for shimming.
6. Use a 4' level, to level the posts. Refer to Figure 8.
7. Shim as required and hammer anchors till they make contact with Baseplate. Do not tighten anchors.
8. Check the distance from the top of the anchor to the floor. If this dimension exceeds 2 1/4" due to floor slope, **DO NOT** use the supplied anchors. Longer anchor must be used (see #2 above).
9. Tighten all anchor bolts to a torque of 150 ft. lbs. Recheck and adjust the level of post(s) and cable(s) if necessary.

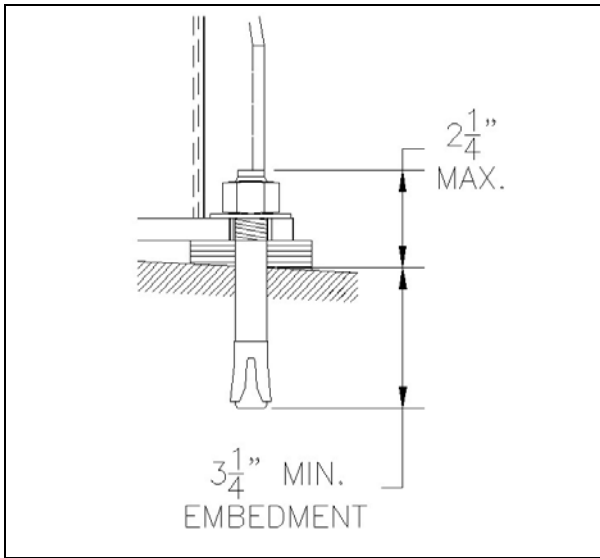

Figure 7. Floor slope

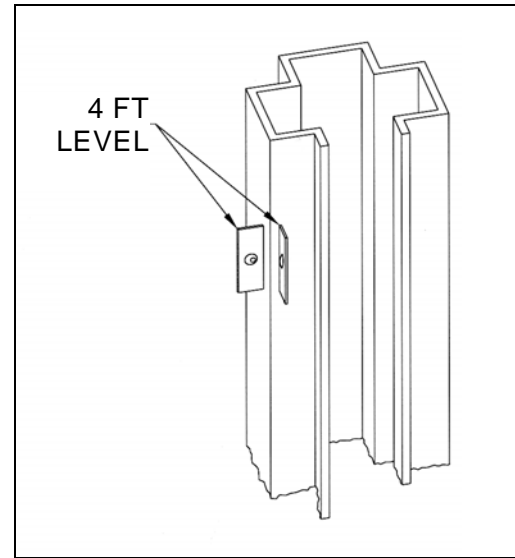

Figure 8. Post leveling

NOTE: THE 3/4" × 5 1/2" LG. WEDGE ANCHOR BOLTS SUPPLIED MUST HAVE A MINIMUM EMBEDMENT OF 3 1/4" INTO CONCRETE FLOOR.

NOTE: IN CASES WHERE THE FLOOR IS EXTREMELY OUT OF LEVEL, THE MECHANICAL SAFETIES MAY NOT ENGAGE ON THE SAME LOCK.

4.5 DECK & CROSSMEMBER INSTALLATION

NOTE: THERE MUST BE 36" BETWEEN THE DECKS WHICH WILL ALLOW THE JACKING BEAMS TO ROLL FREELY.

- Lower decks onto front crossmembers, and work stands located at the rear of the decks.

NOTE: CARE MUST BE TAKEN AS NOT TO PINCH ¼" POLYTUBES PRE-INSTALLED ON DECKS (FRONT & REAR)

- Locate and position the rear crossmember directly underneath the decks. Raise the crossmember to the decks and re-position work stands underneath the crossmember (The deck should fit inside the locating tabs on the crossmember).
- Install eight (8) 1/2 - 13 UNC × 1" lg. set screws to hold the decks to the front and rear crossmember assemblies. One set screw to the front and rear of each deck and one set screw into the four outer locating tabs on the front and rear crossmember assemblies.

4.6 CABLE INSTALLATION

Refer to Figure 4, Figure 5, and Section 8.5

NOTE: A 3/8" - 16 UNC × 3" LG. HEX HEAD BOLT MUST BE REMOVED FROM THE CROSSMEMBERS TO ALLOW CABLE INSTALLATION AROUND THE PULLEYS. THIS 3/8" - 16 UNC × 3" LG. HEX HEAD BOLT MUST BE RE-INSTALLED AFTER THE CABLES ARE ROUTED THROUGH THE CROSSMEMBER ASSEMBLIES.

- Refer to Figure 4, Cable and Routing Diagram.
- Check for correct arrangement of spacers on sheave stacks, Figure 5.
- Install the sheave into the front of the right deck as shown in Figure 5 and Section 8.5.
- Continue routing the non-threaded end of cable #4 (Part # 2-1507) located at the opening on the right side of the front crossmember assembly.

NOTE: MAKE CERTAIN THAT THE CABLE RUNS BETWEEN THE WELDED GUIDE PIN AND THE GROOVE IN THE PULLEY AS SHOWN IN FIGURE 8.

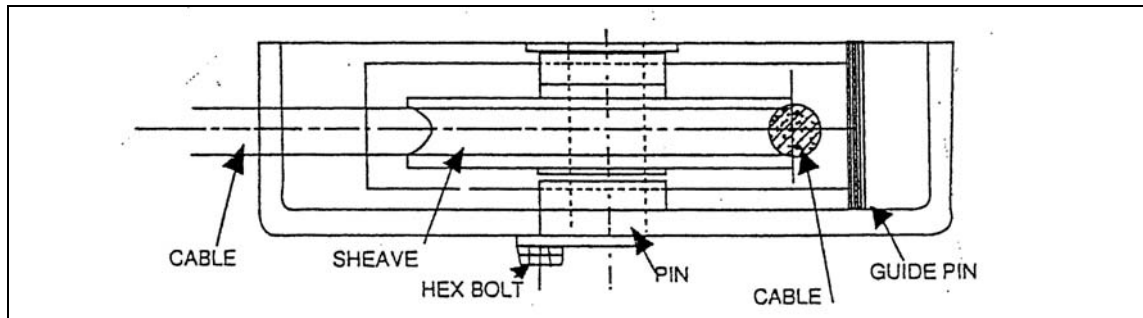

Figure 9. Sheave stack

NOTE: Typical deck sheave arrangement. Left and right front deck shown; cable must run between the welded guide pin and the groove in the sheave. Left and right front spacers have equal top and bottom sizes.

NOTE: Similar arrangement for sheave stack. **Right side deck rear spacer sizes are not equal - larger goes on top of stack.**

- Continue to pull cable #4 over the center support of the right deck.
- Begin routing cable #3 (Part # 2-1506) from the right rear crossmember assembly using the non threaded end of the cable as described in Figure 4, and out through the crossmember assembly to the opening under the rear of the right deck.
- Continue to feed cables #3 and #4 through the rear crossmember assembly and out of the opening under the rear of the left deck.
- Install the sheave into the rear of the right deck as shown in Section 8.5, and Figure 5.
- Route cable #2 (Part # 2-1505) from the left side of the rear crossmember assembly using the non threaded end of the cable as described in Figure 4, and out through the crossmember assembly to the opening under the rear of the left deck.
- Continue routing the non-threaded end of cable #1 (Part # 2-1504) located at the opening on the left side of the front crossmember assembly.
- Install the sheave into the front of the left deck as shown in Section 8.5, and Figure 5.

NOTE: MAKE CERTAIN THAT ALL CABLES ARE IN THE RIGHT POSITIONS AND ARE NOT TWISTED. VERIFY THAT ALL FOUR (4) OF THE 3/8"-16 UNC × 3"LG. HEX HEAD BOLTS ARE REINSTALLED ON THE CROSSMEMBER ASSEMBLIES.

- Install the sheave stack assembly at the rear of the left deck as shown in Section 8.5, and Figure 5, Sheave Installation.

NOTE: ALL POSTS HAVE THE SAFETY RACKS ALREADY INSTALLED. THE LEFT FRONT POST WILL HAVE A MOUNTING BRACKET FOR THE POWER PACK INSTALLATION.

- Stand rear posts into position according to Figure 1 and Figure 2.
- Install the threaded stud end of the cables through the top of the post. Use a 7/8" flat washer, and two (2) 7/8"-14 UNF hex nuts with cable spacers as required, to compensate for uneven floors.

NOTE: Install power pack and hydraulic hose before attempting to extend cylinder rod for cable installation.

4.7 POWER PACK INSTALLATION

- Install the power pack to the mounting bracket on the front face of the left front post using four (4) 5/16"-18UNC × 1"LG. hex head bolts and 5/16" lockwashers & flatwashers.
- Install 90° hydraulic elbow fitting on powerpack (See Section 8.4, Item #10)

NOTE: WHEN WORKING WITH HYDRAULIC LINES AND VALVES, IT IS IMPORTANT TO KEEP ALL COMPONENTS CLEAN AND FREE OF DIRT.

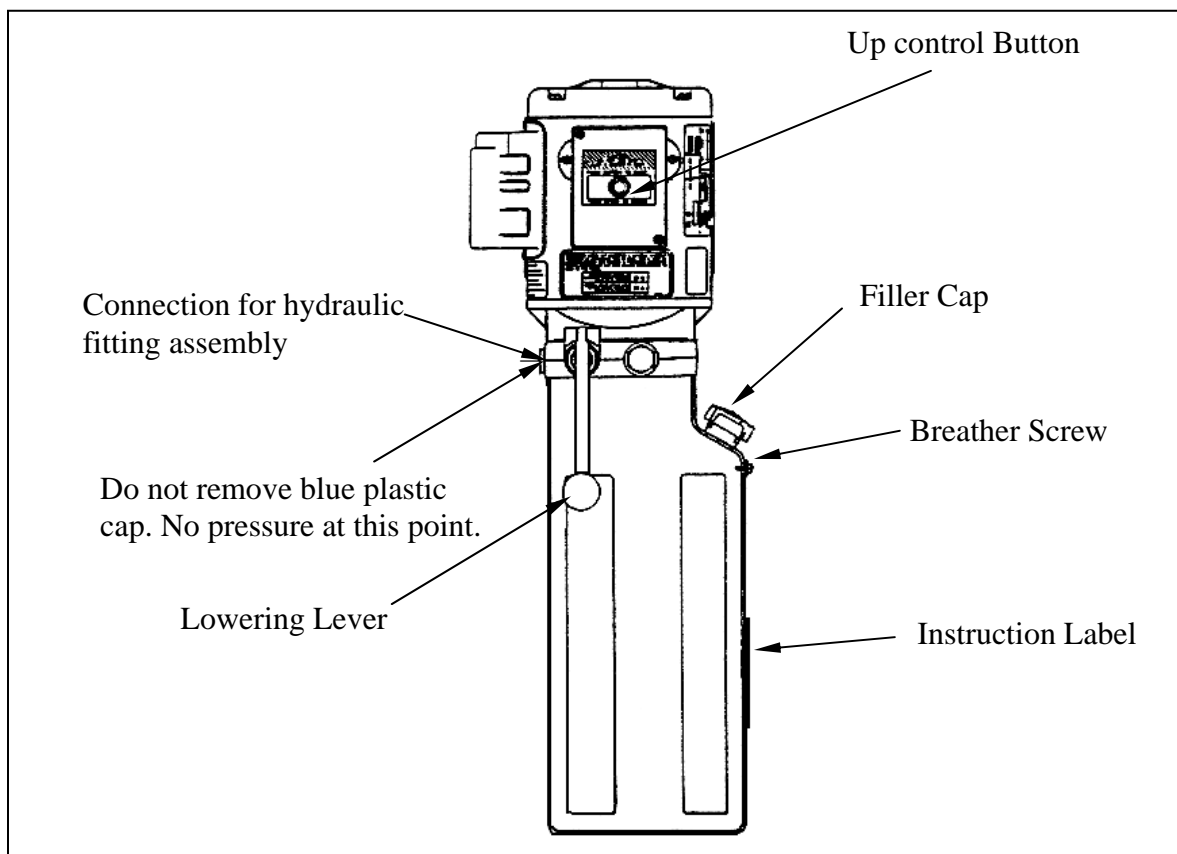

Figure 10. Power pack details

4.8 HYDRAULIC INSTALLATION

- Refer to Parts Manual, Hydraulic and Air Kit Diagram
- Locate the supply lines: 1/4" and 3/8" polytube, 3/8" flexible hydraulic line, and install the hose guard covering all three lines.
- Install the hose guard through the opening provided on the front left crossmember assembly.

TIP: TAPE ONE END OF THE HYDRAULIC HOSE TO THE TWO POLYTUBES AND FEED THEM THROUGH THE HOLE IN THE FRONT LEFT CROSSMEMBER. NOW REMOVE THE TAPE.

- Connect the 3/8" JIC-F SWIVEL end of the flexible hydraulic hose to the fitting at the cylinder. **DO NOT OVER TIGHTEN.**
- Install the flow control assembly making sure the **direction of the arrow on the flow control is facing towards the power pack. Refer to Section 8.3, item 17.**
- Attach the other end (3/8" JIC-F SWIVEL) of the flexible hydraulic hose to the adapter fitting on the flow control (3/8" JIC, M SWIVEL).

4.9 ELECTRICAL CONNECTIONS

CAUTION: A QUALIFIED ELECTRICIAN SHOULD MAKE ALL ELECTRICAL CONNECTIONS.

Please refer to Figure 10, Electrical Diagram for 230 volts/1 phase electrical connections.
Electrical Breaker Size Recommendation: 25Amps

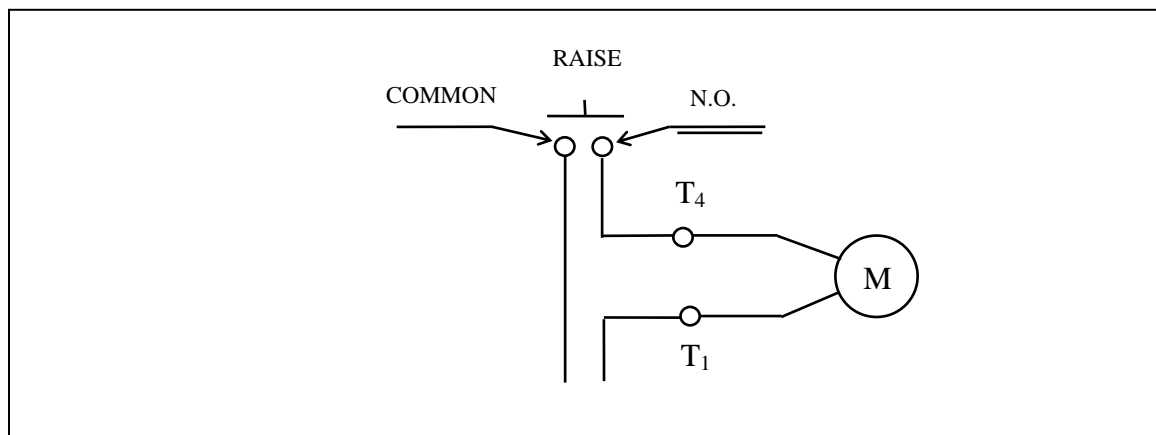

Figure 11. Electrical diagram for 230 V/1ph

NOTE: THE CYLINDER ROD MUST BE EXTENDED IN ORDER TO INSTALL THE NON-THREADED END OF THE CABLES TO THE CABLE FLANGE ON THE ROD.

- Remove the hydraulic cap from the fitting at the base of the hydraulic cylinder.
- Depress the lowering lever, and at the same time use an air chuck to blow air into the fitting in the breather hole in the base of the cylinder to extend the rod.
- Continue to extend the rod until the non-threaded ends of the cables are reached.
- Remove the clamp from the cable flange. Ensure that the cable flange is installed with the counterbores facing towards the hydraulic cylinder as shown in Figure 12 and install the cables.
- Tighten the hose clamp on the cable flange to secure all the cables. Ensure that the two retaining nuts are positioned as shown in Figure 12. Using two wrenches, lock the retaining nuts against each other.

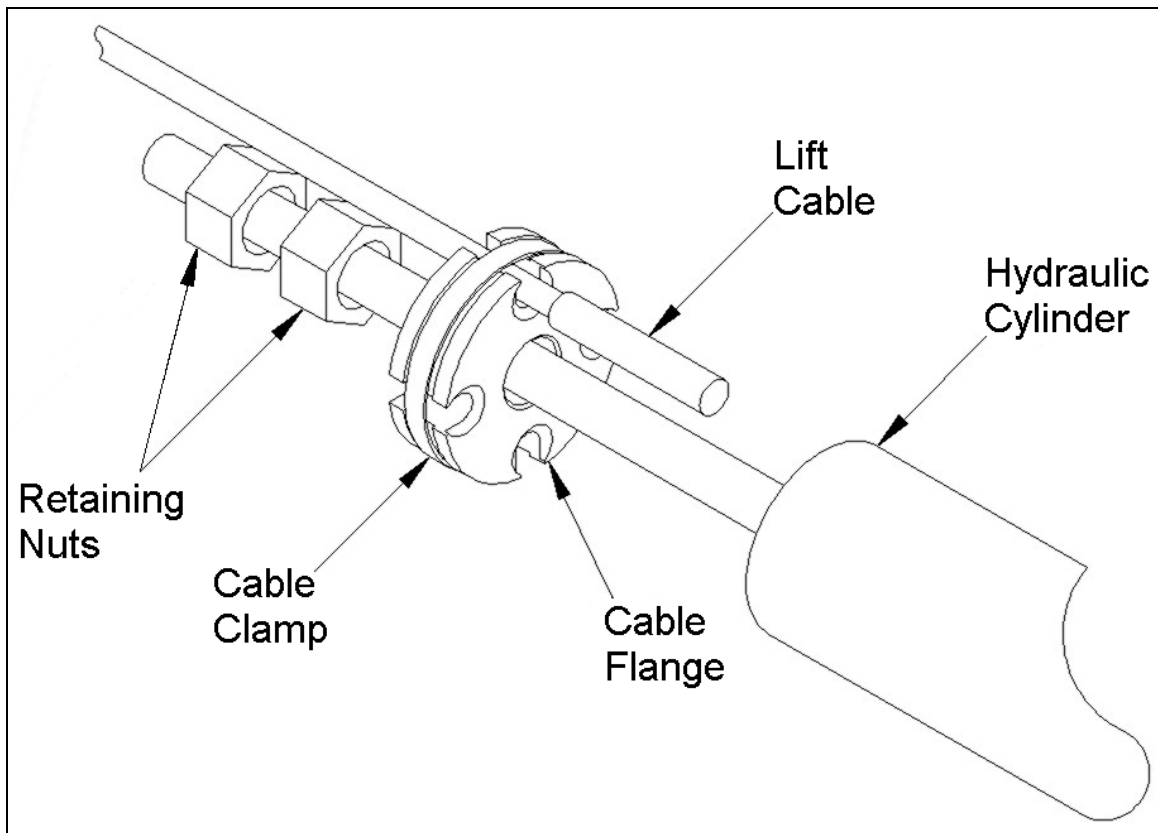

Figure 12. Cable Installation at Flange

4.10 AIR INSTALLATIONS

- The air valve assembly is factory installed, and is found on the outside face of the left front post protected by the mounting bracket.

NOTE: MOST OF THE 1/4" AND 3/8" POLYTUBE CONNECTIONS HAVE BEEN MADE IN THE REAR CROSSMEMBER ASSEMBLY AND BOTH DECKS - ONLY FINAL CONNECTIONS ARE REQUIRED. THE 1/4" POLYTUBE IS USED FOR THE AIR CYLINDER LOCKS AND THE 3/8" POLYTUBE IS USED FOR THE AIR OUTLETS TO THE JACKING BEAMS.

CAUTION: DO NOT OVER TIGHTEN CONNECTORS.

- Connect all of the 1/4" polytubes, coming out of the front & rear left crossmember assemblies, to the cross and tee pushlock fittings. See Hydraulic and Air diagram (Page 33)
- Connect the opposite end of the 1/4" polytube, to the air valve on the outside face of the left front post.
- Connect the 1/4" polytubes on the front and rear right sides of the deck using two (2) 1/4" pu adapters (Part #6-3202).
- Connect the 3/8" polytube, coming out of the front left crossmember assembly to the 3/8" polytube fitting located under the front inside of the left deck.
- Connect the opposite end of the 3/8" polytube, coming out of the front left crossmember assembly to the air valve outlet on the outside face of the left post.

NOTE: FOR THOSE UNITS EQUIPPED WITH JACKING BEAMS, THIS WOULD BE THE TIME TO INSTALL THEM. CONSULT THE JACKING BEAM INSTRUCTION MANUALS ARE FOUND IN EACH JACK BEAM BOX.

- Hook up an air supply to the inlet of the water trap on the air valve assembly located on the outside of the left post. Check for air leaks.

- Check the operation of the air cylinder locks by depressing the button attached to the air valve on the outside of the left front post.
- Fill reservoir with hydraulic fluid (ISO 32) at this time.
- Attach the hydraulic line to the inside of the left deck using the two 3/4" hose clamps and self threading screws found in the accessory box.
- Press the "UP" button on the hydraulic power pack. Continue raising the lift until it is supported fully by the cables.

NOTE: MAKE CERTAIN THAT THE MECHANICAL SAFETY LOCKS AND CABLE ROLLERS ARE WORKING PROPERLY.

4.11 SAFETY RETAINING SYSTEM

- Assemble the safety retainer bracket assemblies using the supplied hardware as shown in Section 8.7
- Install one 5/16" x 3/4" long hex head bolt with one 5/16" lock washer into the top mounting hole location on the crossmember but do not tighten. Leave at least 3/16" space between the lock washer and the crossmember.
- Insert the bracket assembly inside the post and slide up into place between the post and the crossmember so that the bolt and lock washer slide into the upper slot.
- Install the second 5/16" x 3/4" long hex head bolt and 5/16" lock washer through the lower slot and into the bottom mounting hole in the crossmember. Tighten both of the bolts. See Figure 13.
- Repeat for all sides of rear crossmember.

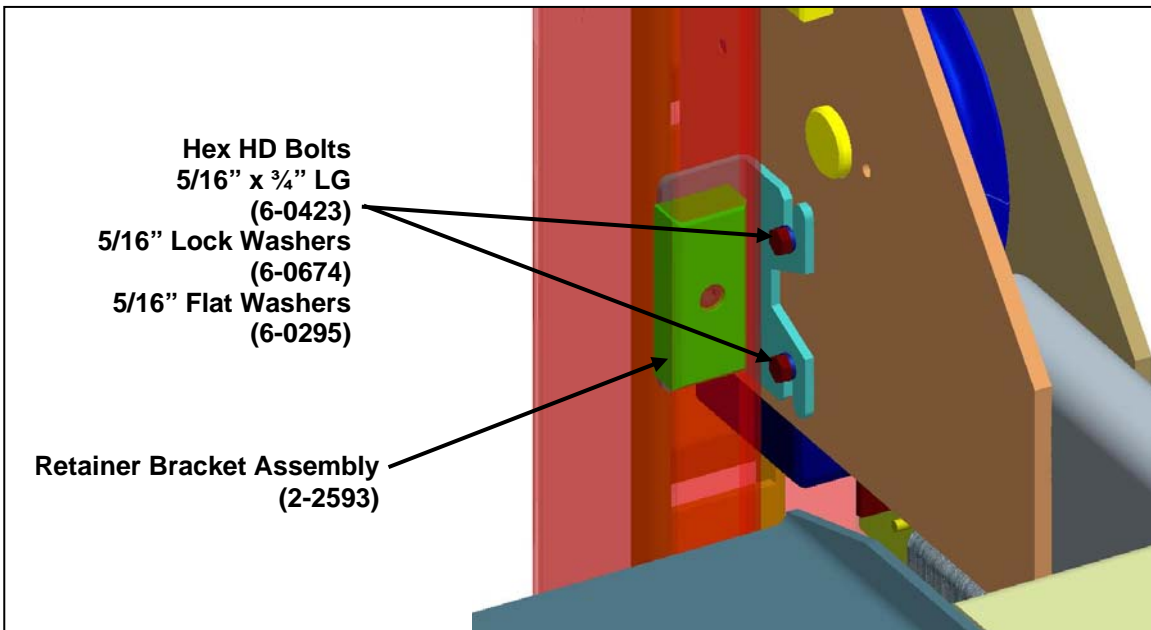

Figure 13. Retainer bracket installation

4.12 ANCHOR INSTALLATION – REAR POSTS

- Recheck all measurements before anchoring rear posts. Refer to note at bottom of page.
- Refer to section 4.4 for anchoring instructions for rear posts.

NOTE: MAKE CERTAIN THAT THE SAFETY RACK IN EACH OF THE POSTS IS SQUARE TO THE CROSSMEMBER ASSEMBLY AND THAT A CLEARANCE OF 1/8" IS MAINTAINED BETWEEN THE INSIDE FACE OF THE POSTS AND THE PLASTIC GUIDES ON THE REAR CROSSMEMBER ASSEMBLY.

4.13 LEVELING PROCEDURE - CABLES

- All cable adjustments can be made at the threaded end of the cable at the top of each of the four (4) posts.
- Tighten the two (2) 7/8" - 14 UNF hex nuts on each cable at the top of each post.
- Recheck to make certain that the safeties are engaging together.
- Raise the lift to check for full operating height of 71". This measurement is taken from the top of the decks to the floor.
- Install the approach ramps using ramp pins, cotter pins, washers, and ramps provided. Ensure the proper operation of the ramps.
- Install the front wheel stops using six (6) 1/2" - 13 UNC × 1" lg. hex bolts and six 1/2" lockwashers.
- Install the four (4) sheave covers over the sheaves in the crossmember assembly.
- Cycle the lift several times to check proper operation of the cables, safety lock, air locks, etc.

STOP IMMEDIATELY IF THE LIFT IS NOT OPERATING PROPERLY.

- Adjust and recheck for proper operation.

4.14 LEVELING PROCEDURE – SAFETY LADDERS

- Park lift on safety locks.
- Using a 4' level, adjust the safety ladders to level the lift.
- To do this loosen the 3/8" - 16 UNC × 1" lg. hex bolts at the bottom and top back of each post and pull safety ladders up until they come into full contact with each of the safety shoes on the crossmember assemblies.
- When level, tighten the two (2) 5/8" - 11 UNC hex nuts at the top of each safety rack and the 3/8" - 16 UNC × 1" lg. hex bolts at the bottom and top back of each post.
- Check to see if ladders engage evenly.
- If the ladders do not engage evenly, adjust cables by jogging the lift until the first safety lock engages and then tighten the other three corners until each safety lock clicks.

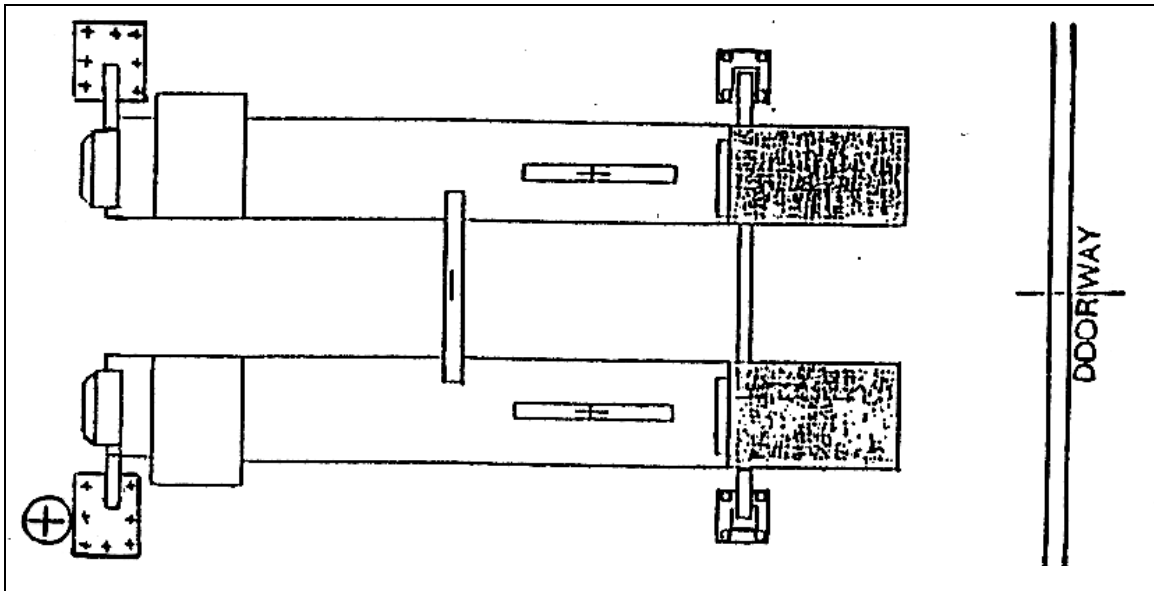

Figure 14. Deck leveling

CAUTION: USE THE CORRECT WEDGE ANCHOR BOLTS. (SUPPLIED)

NOTE: Check and adjust the decks for level using the 4' level. Both the front plate cut-outs and rear steer plates should be checked.

4.15 FINAL CHECK OF ASSEMBLED LIFT

1. Final dimension check after anchoring. _____
2. Check for air and hydraulic leaks. _____
3. Ensure cables are properly routed and free from obstructions. _____
4. Ensure all safety lock mechanism are working correctly. _____
5. Re-check level of post and decks. _____
6. Makes sure ramps are secured correctly with cotter pins and washers. _____
7. Check all fasteners, tighten if necessary. _____
8. Check direction of flow control (arrow pointed toward power unit). _____
9. If jack beams are supplied, ensure keeper bracket are installed. _____
10. Check jam nuts on cables and safety ladders are tightened. _____
11. Ensure cable flange clamp is installed correctly and tighten. _____
12. Ensure cylinder shaft Jam Nuts are installed as per instructions. _____
13. Ensure wheelstops are installed. _____
14. Ensure wheel chocks are provided. _____
15. Operate lift to full stroke then lower to ground while checking for proper functionality. _____
16. Ensure Customer Care Kit is complete and given to operator. _____
 - a. Operation Manual _____
 - b. ANSI / ALI Lift It Right Manual _____
 - c. ANSI / ALI Safety Tip Card _____
 - d. ANSI / ALI ALIS Safety Requirements for Installation and Service of Automotive Lifts _____
 - e. ANSI / ALI Quick Reference Guide _____
17. Train end user on operation of the lift. _____

4.16 OPERATION TEST WITH VEHICLE

1. Lower lift to ground.
2. Drive vehicle on to lift, install wheel chocks.
3. Raise lift to and lower onto 3-4 lock positions during full rise to ensure all locks are working correctly.
4. Double check level of runways, front to rear and side to side while on locks.
5. Re-adjust cables if necessary while vehicle is on.
6. Check lowering speed and smooth decent rate.
7. Lower lift to ground, remove wheel chocks and drive vehicle off lift.

If any problems occur during the final checkout or operation of the lift please contact customer service at 1-800-268-7959

5.0 SAFETY AND OPERATING INSTRUCTIONS

1. **Inspect** your lift daily. Do not operate it if malfunctions occur or damaged parts have been found.
2. **Never** attempt to **overload** the lift. The manufacturer's rated capacity is shown on the serial number tag on the power post.
3. Operating controls, **DO NOT OVERRIDE** the safeties. The mechanical safeties are designed to engage automatically on the way up. Press the up button on the power pack to go up. When the desired height is reached, release the power pack up button and lower onto the safety. To lower, raise the lift off of the safety locks then press the air release valve button and the lowering release lever at the same time.
4. **Only trained** and authorized personnel should operate the lift. Do not allow customers or bystanders to operate the lift or be in the lift area.
5. **Caution**, never work under the lift unless the mechanical safety locks are engaged.
6. **Before driving** vehicle on, make sure lift is in the fully down position.
7. **Before removing** the vehicle from the lift, make sure the lift is in the fully down position and ensure that all tools have been removed from the deck surfaces.
8. **Always keep** the lift area free from debris. Grease and oil spills should always be cleaned up immediately. **Never leave** any tools or parts lying on the decks.
9. **Never operate** lift with passengers in vehicle.

NOTE: DO NOT ATTEMPT TO OPERATE THIS LIFT IF ANY PART IS NOT WORKING PROPERLY OR YOU HAVE NOT READ THE COMPLETE OPERATING INSTRUCTION MANUAL.

NOTE: DO NOT RAISE OR LOWER THE LIFT WITH VEHICLE ON THE JACKING BEAM

Installation shall be performed in accordance with ANSO/ALI ALIS, Safety Requirements for Installation and Service of Automotive Lifts

For additional safety instructions regarding lifting, lift types, warning labels, preparing to lift, vehicle spotting, vehicle lifting, maintaining load stability, emergency procedures, vehicle lowering, lift limitations, lift maintenance, good shop practices, installation, operator training and owner/employer responsibilities, please refer to “Lifting It Right” (ALI/SM) and “Safety Tips” (ALI/ST).

For additional instruction on general requirements for lift operation, please refer to “Automotive Lift-Safety Requirements For Operation, Inspection and Maintenance” (ANSI/ALI ALOIM).

6.0 SAFETY AWARENESS

AUTOMOTIVE LIFT INSTITUTE (ALI)

Automotive Lift Institute, Inc.



The messages and pictographs shown are generic in nature and are meant to generally represent hazards common to all automotive lifts regardless of specific style.

Funding for the development and validation of these labels was provided by the Automotive Lift Institute, PO Box 85 Cortland, NY 13045.

Replacement label sets may be obtained from the original lift manufacturer and ALI's member companies. They are protected by copyright.

www.autolift.org

© 2009 by ALI, Inc.

ALI/WL200c



NOTICE



Do not operate a damaged lift.

The messages and pictographs shown are generic in nature and are meant to generally represent hazards common to all automotive lifts regardless of specific style.

Funding for the development and validation of these labels was provided by the Automotive Lift Institute, PO Box 85 Cortland, NY 13045.

Replacement label sets may be obtained from the original lift manufacturer and ALI's member companies. They are protected by copyright.

www.autolift.org

© 2009 by ALI, Inc.

ALI/WL200s

WL200 Series Label Kit



The messages and pictographs shown are generic in nature and are meant to generally represent hazards common to all automotive lifts regardless of specific style.

Funding for the development and validation of these labels was provided by the Automotive Lift Institute, PO Box 85 Cortland, NY 13045.

Replacement label sets may be obtained from the original lift manufacturer and ALI's member companies. They are protected by copyright.

www.autolift.org

© 2010 by ALI, Inc.

ALI/WL200w

7.0 RECOMMENDED MAINTENANCE GUIDELINES

SAFETY INSTRUCTIONS

- Read operating and safety manuals before using any lift
- Do not operate a lift that has been damaged or is in disrepair
- Proper inspection and maintenance is necessary for safe operation.
- An in-line filter/regulator/lubricator should be installed on all airlines and maintained weekly.

4-POST: DAILY

- Check general operation of lift.
- Check operations of mechanical safety locks.
- Check all air and hydraulic lines and fittings for pinch points, damage , cracks or leaks.
- Check all electrical wiring for pinch points, cracks or damage.
- Check operation of cables and pulleys.
- Check and drain water trapped in filter bowl.
- Check all moving parts for uneven or excessive wear.
- Repair or replace all damaged, defective, worn or broken components Immediately.
- Clean roller jack rails

4-POST: MONTHLY

- Check anchor bolts (if loose re-torque to 150 ft. lbs.). Replace concrete if anchors continue to loosen.
- Check all air and hydraulic hoses, fittings and cylinders for leaks.
- Check level of oil in power pack reservoir when lift is in the lowered position. Add if required.
- Check cables for fraying and adjustment. Lubricate cables with cable or penetrating oil every six months.
- Check all fasteners and tighten as required.
- Check all sheaves on crossmember assembly and under the runways for wear or play. Replace immediately. Pulley pins are held in place by 3/8" - 16UNC x 1"lg. Hex Hd. bolts. Make certain that these bolts are in position and tight.

WARNING!!!

DO NOT APPLY LUBRICANT TO SHEAVE ASSEMBLY. FIBRE BUSHING IS PTFE SELF-LUBRICATING. THE ADDITION OF LUBRICANT WILL SHORTEN THE LIFE OF THE FIBRE BUSHING.

- Check and adjust safety racks if lift is not level on safety, or if safeties do not engage properly.
- If lift is equipped with rear slip plates > dismantle, clean, touch up deck surface if required, and rotate bearing cage every four months (more frequent if necessary)
- Lubricate all safety shoes and locks every six months.
- Clean front turntable bearing cage with air.
- If lift is equipped with slide blocks, clean and re-grease slide block channels in each column every two months
- Change hydraulic oil every two years.

QUARTERLY SLIP PLATE MAINTENANCE

- Remove top Slip Plate covers by first removing the four (4) shoulder bolts on each cover.
- Remove polyethylene-bearing cages insuring that all the delrin bearings remain in the cages. Additional delrin bearings may be purchased if required.
- Clean runway surface and touch up any paint wear with a rust resistant paint. Allow paint to dry thoroughly.
- To obtain optimum performance, the position of the slip plate bearing cage should be rotated every quarter to change the wear pattern. With the first quarter maintenance, flip the bearing cage over to the opposite side. With the second quarter maintenance, rotate the bearing cage end-to-end. With the third quarter maintenance, flip bearing cage over to the opposite side. Fourth quarter maintenance should see the bearing cage rotated back to the position it started in.
- Quarterly maintenance will optimize performance and contribute to longer slip plate life.

ROLLING AIR JACKS

- An in-line filter/regulator/lubricator should be installed close to the pump . Add a few drops of oil to the air intake weekly if no lubricator is used or when idle for a long period of time.
- Lubricate roller bearings and roller guide springs every two months
- Dismantle and clean lift arms every four months
- Clean and lubricate lower cam rollers and hinge points every six months
- Clean and lubricate safety mechanism every six months
- Change hydraulic oil every two years

LUBRICATION

- Where grease is required > multi-purpose lithium grease
- Where lubricating oil is required > multi-purpose SAE 30 lubricating oil
- Where hydraulic oil is required > ISO 32 10W - non detergent hydraulic oil

8.0 PARTS MANUAL

8.1 LIFT ASSEMBLY

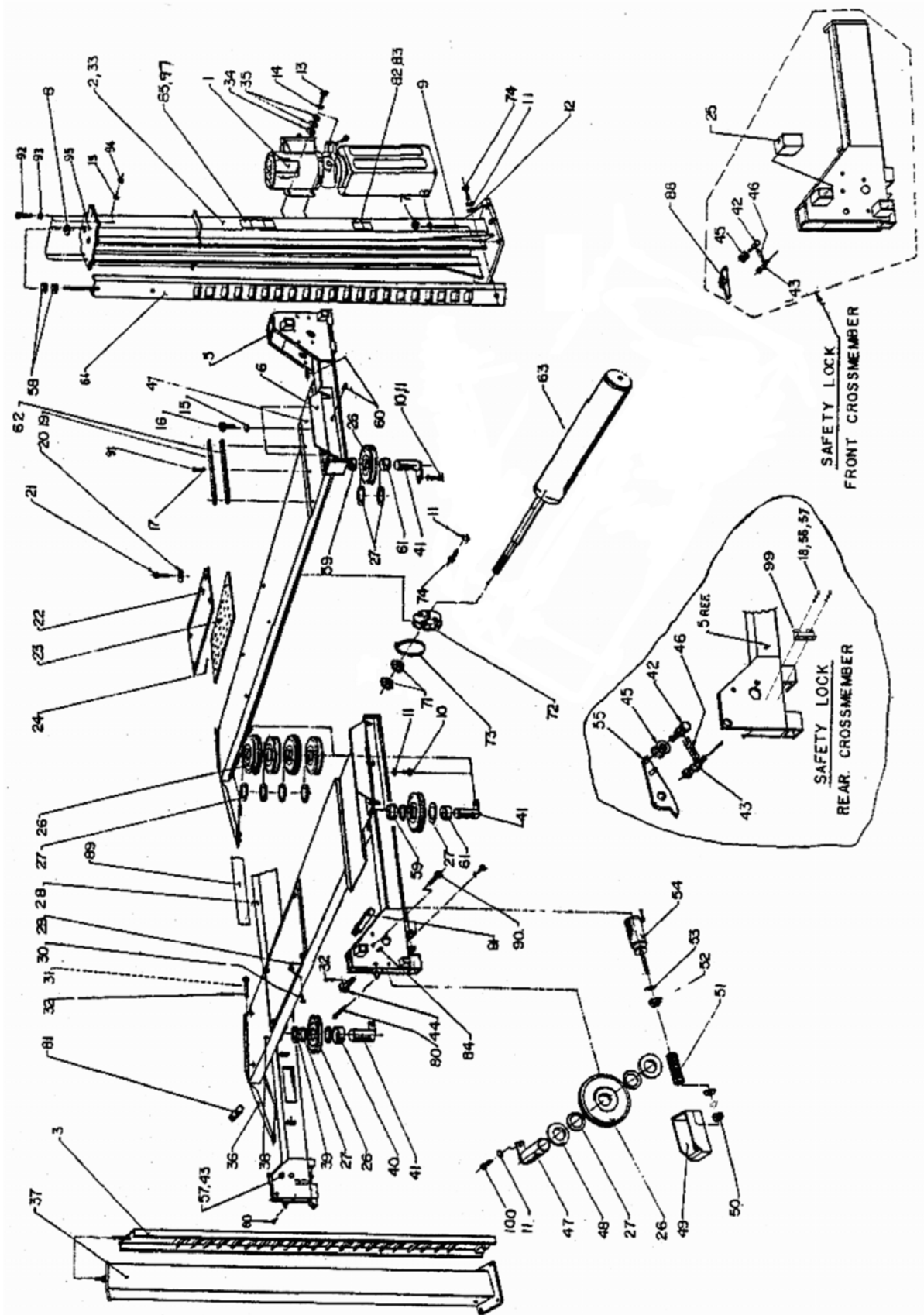

8.2 LIFT PARTS LIST

ITEM	QTY.	DESCRIPTION	PART #
1	1	POWER PACK, 230V/1PH/3HP	6-1398
2	1	POWER POST WELDING (L.S.)	4-0429
3	2	SAFETY RACK WELDMENT (REAR)	3-0487
4	1	ALIGNMENT DECK WELDMENT (LEFT SIDE)	4-0679
5	1	FRONT CROSSMEMBER WELDMENT (LEFT SIDE)	4-0366
6	2	FRONT WHEEL STOP WELDMENT	2-0998
7	22	HEX NUT, 3/4"-10UNC	6-0737
8	30	FLAT WASHER, 3/4" I.D.	6-0738
9	18	WEDGE ANCHOR, 3/4"-10UNC X 5 1/2"LG.	6-1379
10	4	HEX HD. BOLT, 3/8"-16UNC X 1"LG. GR.8	6-0668
11	16	LOCKWASHER, 3/8" I.D.	6-0058
12	6	FLAT WASHER, 3/8" I.D.	6-0625
13	4	HEX HD. BOLT, 5/16"-18UNC X 1"LG.	6-0293
14	4	LOCKWASHER, 5/16" I.D.	6-0674
15	12	LOCKWASHER, 1/2" I.D.	6-0059
16	6	HEX HD. BOLT, 1/2"-13UNC X 1"LG.	6-0045
17	12	LOCKWASHER, 1/4" I.D.	6-0056
18	8	HEX HD. BOLT, 5/16"-18 UNC 3/4"LG.	6-0423
19	4	RETAINING BAR	2-0635
20	8	FLAT WASHER 2"O.D X 13/32I.D. X 3/32	6-0426
21	8	SHOULDER BOLT 3/8" X 5/8"LG.	6-0069
22	2	REAR SLIP PLATE (FULL FLOATING)	3-0197
23	2	BEARING CAGE	3-0196
24	1 SET	1/4" BALL BEARING	6-0829
25	8	GLIDE BEARING	2-0772
26	11	SHEAVE ASSEMBLY	2-0557
27	21	NYLON THRUST WASHER	1-0757
28	1	REAR CROSSMEMBER (WELDING)	4-0371
29	4	LOCKING PIN ASSEMBLY	2-0637
30	4	SELF TAP SCREW #10 X 1/2"LG.	6-0505
31	4	RAMP PIN	1-1887
32	4	COTTER PIN, 1/8" X 1 1/2" LG.	6-0978
33	1	POST WELDING (FRONT - R.S)	4-0430
34	4	HEX NUT, 5/16UNC GR.5	6-0294
35	8	FLAT WASHER, 5/16" I.D.	6-0295
36	2	RAMP ASSEMBLY W/ ROLLER	3-0905
37	2	REAR POST WELDING	3-0347
38	1	ALIGNMENT DECK WELDMENT, (RIGHT SIDE)	4-0680
39	1	SHEAVE-SPACER 2 1/2"LG.	1-0798
40	1	SHEAVE-SPACER 1 1/4"LG.	1-0788
41	4	DECK SHEAVE PIN	2-0566
42	2	SHOULDER BOLT 3/8"DIA. X 1"LG.	6-0206
43	6	SHOULDER BOLT 3/8" DIA. X 5/8"LG.	6-0069
44	4	LOCK SAFETY PIN (WELDING)	1-1234
45	4	CABLE ROLLER	1-0766
46	8	TENSION SPRING	1-0768
47	4	CROSSMEMBER SHEAVE PIN	1-0771
48	8	SHEAVE SPACER, 3/8" LG	1-0768

ITEM	QTY.	DESCRIPTION	PART #
49	4	SAFETY SHOE WELDMENT	2-0990
50	4	HEX. NYLON LOCKNUT, 1/4"-28UNF	6-1563
51	4	COMPRESSION SPRING	1-0767
52	4	HEX. NUT, 5/8"-18UNF	6-0662
53	4	INTERNAL TOOTH LOCKWASHER, 5/8" I.D.	6-0663
54	4	AIR CYLINDER (CLIPPARD #SRR-12-2-SP; 5 1/2" ROD EXT.)	6-0651
55	1	LOCK-SAFETY LS	2-0567
	1	LOCK SAFETY RS	2-1475
56	8	LOCK WASHER 5/16" ID	6-0674
57	8	FLAT WASHER 5/16"	6-0295
58	8	HEX NUT, 5/8"-11UNC, GR.8	6-0673
59	2	SHEAVE-SPACER 1 3/4"LG.	1-0799
60	8	SET SCREW, 1/2"-13UNC X 1" LG. GR.8	6-0726
61	2	SHEAVE-SPACER 2 "LG.	1-0943
62	4	SPACER BAR	2-0636
63	1	HYDRAULIC CYLINDER 3.5"	4-0393
64	2	SAFETY RACK WELDMENT	3-0581
71	2	HEX NUT 1 1/4"-12UNF-2A	6-1454
72	1	CABLE FLANGE	2-1037
73	1	HOSE CLAMP 4 1/2"DIA.	6-0665
74	8	HEX. BOLT 3/8"-16UNC-1 1/4"LG. GR.8	6-0666
80	4	HEX HD. BOLT 3/8"-16UNC X 3"LG.	6-1386
81	4	SHEAVE COVER	2-0997
82	1	SERIAL TAG	6-1306
83	1	"ALI" PLATE	6-0988
84	1	FRONT CROSSMEMBER WELDMENT (RIGHT SIDE)	4-0368
85	1	DECAL SET, ALI/WL 200	6-0988
88	1	LOCK SAFETY LS	2-0980
	1	LOCK SAFETY RS	2-1427
89	1	"CAUTION" TAPE, (40" LG.)	6-1125
90	2	HEX HD. BOLT, 1/2"-13UNC x 3"LG.	6-1381
91	12	HEX HD. BOLT, 1/4"-20UNC x 1 1/4"LG.	6-0027
92	6	HEX HD. BOLT, 1/2"-13UNC x 2"LG.	6-0769
93	16	FLAT WASHER, 1/2" I.D. SAE	6-0248
94	6	HEX NUT, 1/2"-13UNC	6-0035
95	2	TOP PLATE	2-1125
97	1	"ATTENTION" DECAL	6-1637
98	1	KEEPER WASHER, 2"DIA. x 1/4"THK.	1-1766
99	4	SAFETY RETAINER BRACKET ASSEMBLY	2-2593
100	4	HEX BOLT 3/8" x 3/4" LG GR.5	6-0030

8.3 HYDRAULIC AND AIR KITS ASSEMBLY

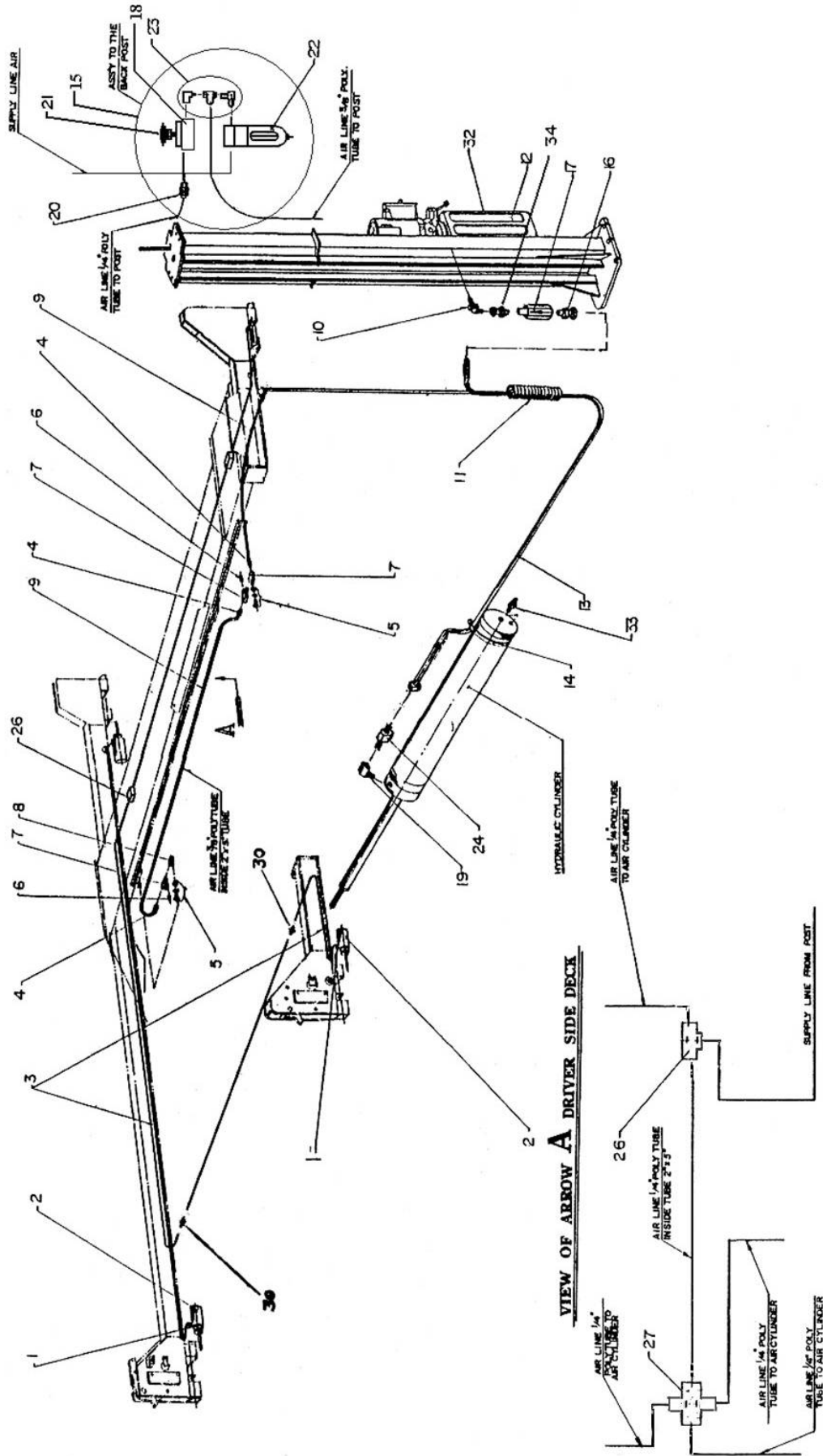

8.4 HYDRAULIC AND AIR KITS ASSEMBLY PARTS LIST

ITEM	QTY.	DESCRIPTION	PART#
1	4	90° ELBOW, 1/8"NPT X 1/4"POLY TUBE	6-0709
2	4	AIR CYLINDER	6-0651
3	1	1/4" DIA. POLY TUBE (50' LG.)	6-0706
4	3	ADAPTER, 3/8" POLY TUBE X 1/4"NPT	6-0710
5	2	TERMINAL BOLT, 3/4"	6-0713
6	2	PLUG, 1/4"NPT	6-0282
7	3	1/4" NPT STREET TEE	6-0014
8	1	1/4" NPT STREET ELBOW	6-0015
9	1	3/8" DIA. POLY TUBE (25' LG.)	6-0707
10	1	90° ELBOW, 3/8"JIC M X 9/16"SAE M	6-0804
11	1	HOSE GUARD (4' LG.)	6-0714
12	1	POWER PACK 230V/1 PH/3 HP	6-1398
13	1	HYD.HOSE ASS'Y, 3/8"JIC-F, 16FT LG.	6-1692
14	3	CABLE TIE	6-0731
15	1	AIR VALVE & FILTER ASS'Y	2-1394
16	1	ADAPTER, 3/8"NPT M X 3/8"JIC M	6-0345
17	1	FLOW CONTROL	6-0090
18	1	3-WAY AIR VALVE	6-1775
19	1	90° ELBOW, 1/4"NPT M X 3/8"NPT F	6-0796
20	1	ADAPTER, 1/4" POLY TUBE X 1/8"NPT	6-0708
21	1	AIR VALVE PUSHBUTTON KIT	6-1777
22	1	AIR FILTER ASSEMBLY	6-0772
	1	AIR FILTER ELEMENT, (REPLACEMENT)	6-0180
23	1	AIR VALVE FITTING KIT	0-0405
24	1	VELOCITY FUSE	6-0025
25	1	PLUG, 1/8" NPT	6-0182
26	1	1/4" POLYTUBE PUSHLOCK CROSS	6-3869
27	1	1/4" POLYTUBE PUSHLOCK TEE	6-2971
30	2	1/4" POLYTUBE ADAPTER	6-0747
32	1	"LIFT OPERATION" DECAL	6-0593
33	1	ADAPTER, 1/8"NPT M X 1/4"JIC M	6-0280
34	1	ADAPTER, 3/8"NPT M X 3/8"JIC F, SWIVEL	6-0797

8.5 CABLE ROUTING DIAGRAM

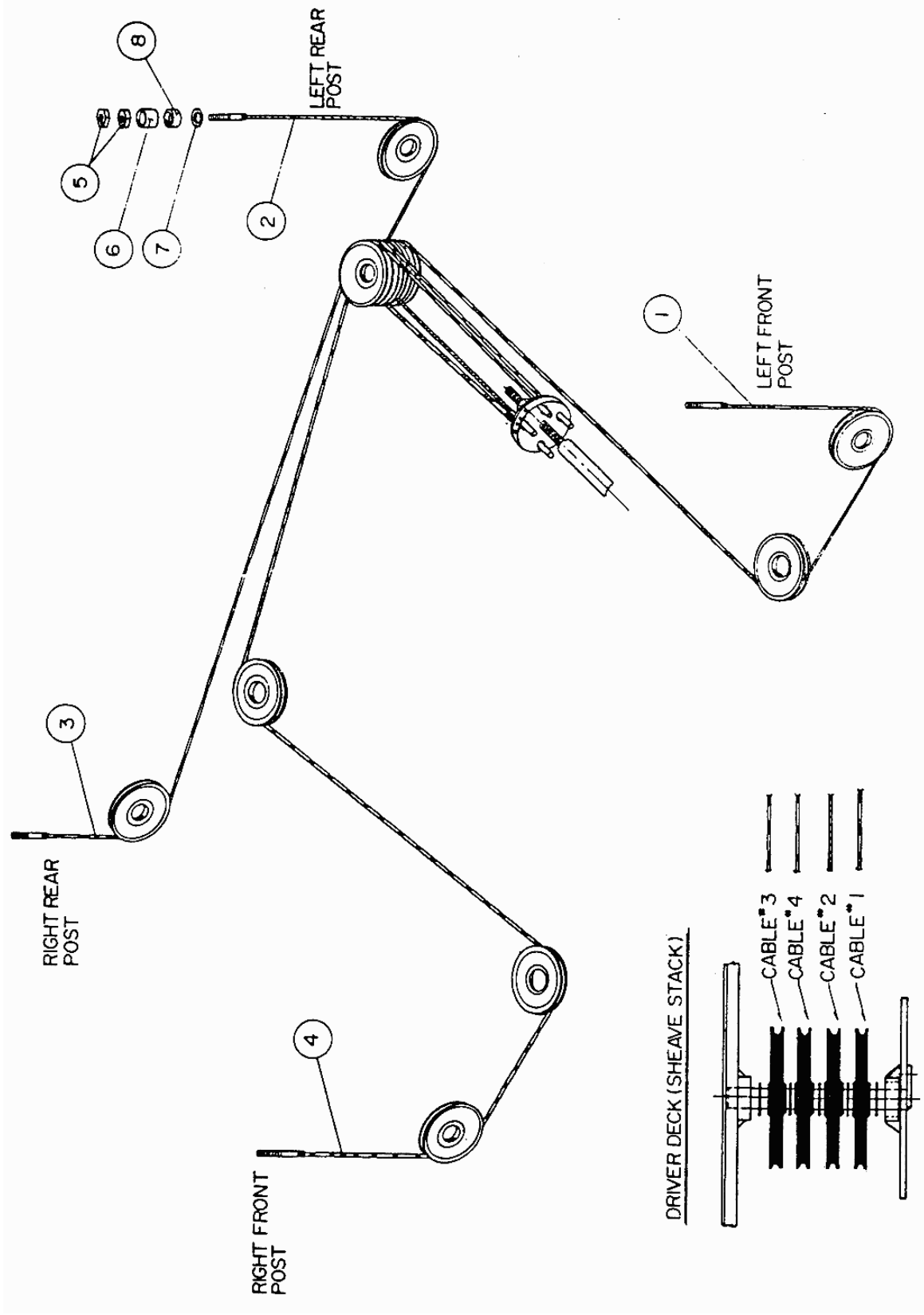

8.6 CABLE ROUTING PARTS LIST

ITEM	QTY.	DESCRIPTION	PART#
1	1	CABLE ASSEMBLY, 404.5"LG. (LEFT-FRONT)	2-1504
2	1	CABLE ASSEMBLY, 157.75"LG. (LEFT-REAR)	2-1505
3	1	CABLE ASSEMBLY, 213.75"LG. (RIGHT-REAR)	2-1506
4	1	CABLE ASSEMBLY, 459.5"LG. (RIGHT-FRONT)	2-1507
5	8	HEX NUT, 7/8"-14UNF, GR.5	6-0724
6	4	CABLE SPACER, 2"LG.	1-0800
7	4	FLAT WASHER, 7/8" I.D.	6-0725
8	4	CABLE SPACER, 1"LG.	1-0801

8.7 SAFETY RETAINER BRACKET

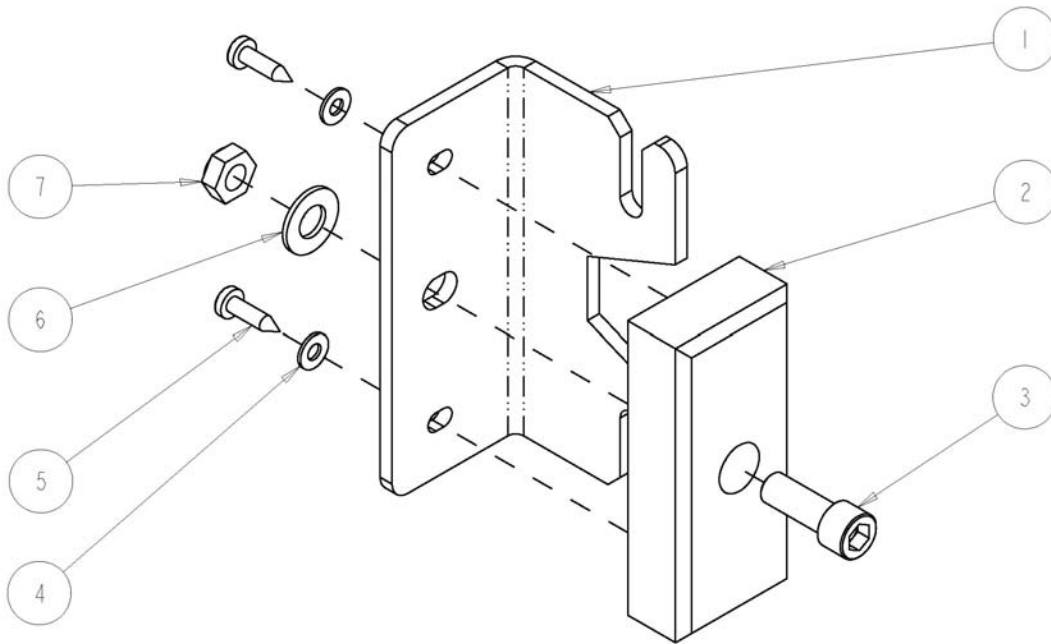

ITEM	QTY.	DESCRIPTION	PART #
1	4	SAFETY RETAINER BRACKET	2-2589
2	4	SAFETY RETAINER PAD	1-1674
3	4	SHCS 3/8" NC x 1" LG	6-2048
4	8	FLAT WASHER #10	6-0816
5	8	SCREW, SELF TAPPING, #10 x 3/4" LG	6-0297
6	4	LOCK WASHER 3/8"	6-0058
7	4	HEX NUT 3/8"-16 UNC GR5 PL	6-0034

8.8 POWER PACK

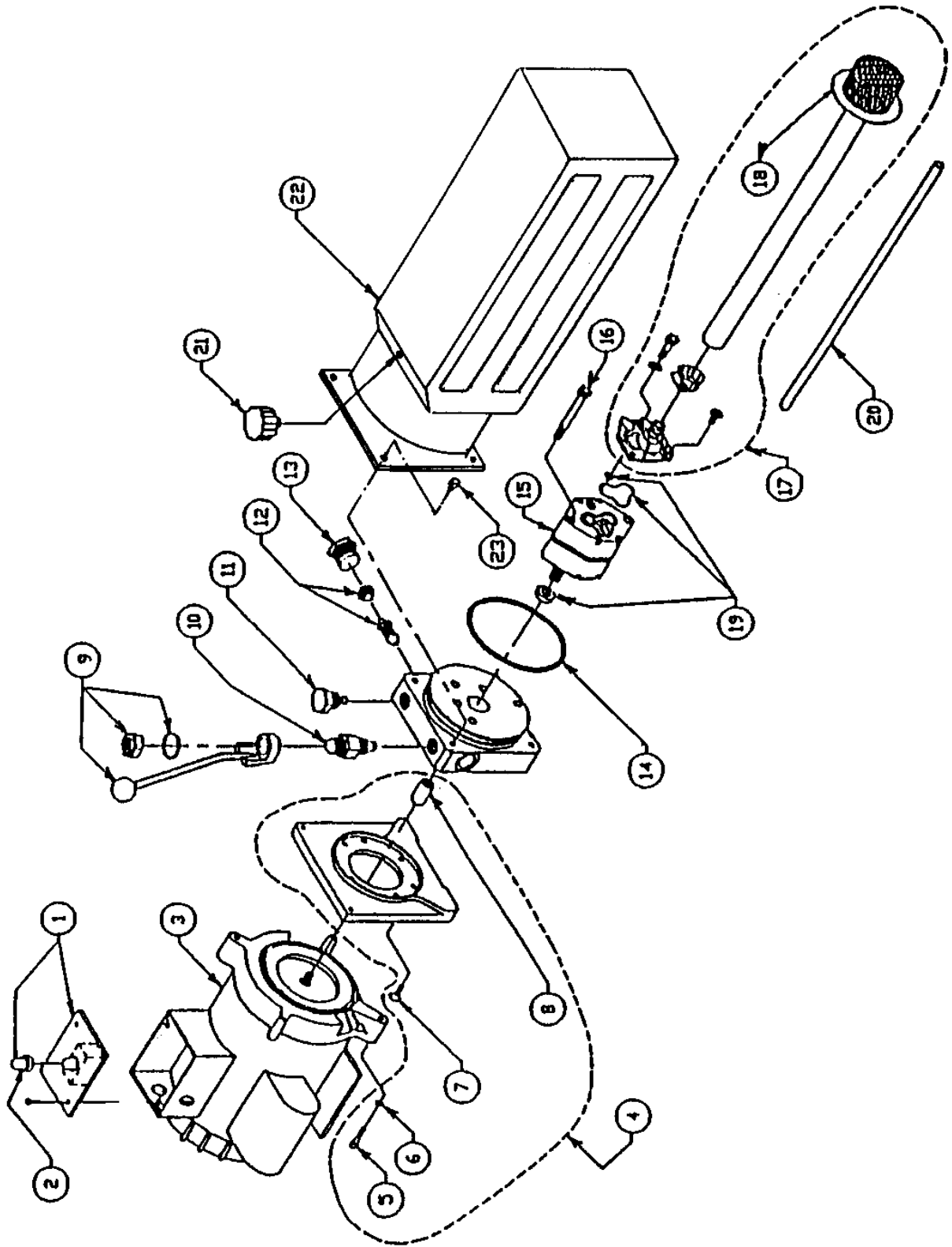

8.9 POWER PACK PARTS LIST

ITEM	QTY.	DESCRIPTION	PART#
1	1	MICROSWITCH AND WIRING ASSEMBLY	6-0881
2	1	MICROSWITCH BOOT	6-1084
3	1	MOTOR, 230V AC, 1 PHASE, 50/60 HZ, 3HP	6-1959
4	1	MOTOR ADAPTER KIT	0-0197
5	4	SOCKET HD.CAP SCW. 1/4"-20UNC X 1 5/8"LG.	6-1085
6	4	LOCK WASHER, 1/4" I.D.	6-0056
7	4	ALLEN FLAT HD.SCW. 1/4"-20UNC X 3/4"LG.	6-1086
8	1	COUPLING	6-0774
9	1	RELEASE BRACKET & HANDLE ASSEMBLY	6-0776
10	1	VALVE CARTRIDGE RELEASE	6-0880
11	1	VALVE CARTRIDGE CHECK	6-1087
12	1	FIXED RELIEF VALVE ASSEMBLY (RV 23)	6-1323
13	1	RELIEF VALVE CAP	6-1089
14	1	RESERVOIR "O" RING	6-0875
15	1	PUMP ASSEMBLY, 2.5CC/REV	6-1958
16	2	PUMP MOUNTING BOLT	6-1090
17	1	INLET PLUMBING KIT	0-0198
18	1	INLET HOSE / FILTER ASSEMBLY	6-0786
19	1	PUMP "O" RING KIT	0-0199
20	1	RETURN TUBE	6-0783
21	1	BREATHER FILLER CAP	6-0784
22	1	RESERVOIR	6-0785
23	4	RESERVOIR SCREW	6-1091

CAUTION







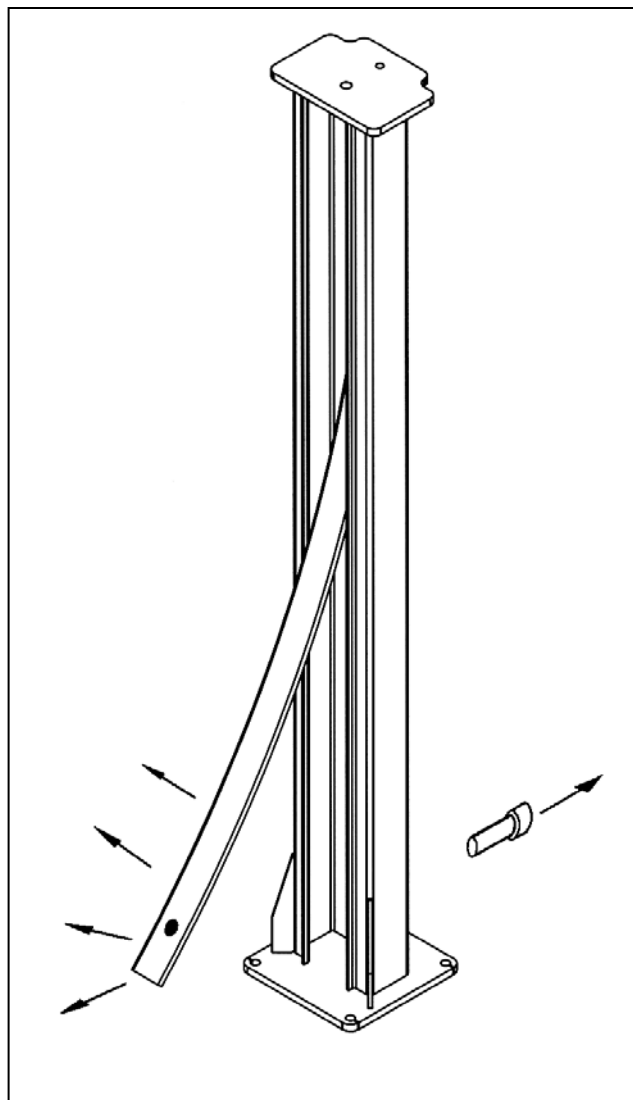

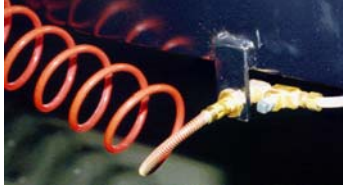

ALL SAFETY LADDERS USED ON 4-POST LIFTS ARE PRELOADED.

REMOVING THE BOLT HOLDING THE BOTTOM PORTION OF THE SAFETY LADDER WITHOUT PROPER PRECAUTIONS CAN RESULT IN INJURY.

PLEASE CONTACT CUSTOMER SERVICE FOR PROPER REMOVAL INSTRUCTIONS.

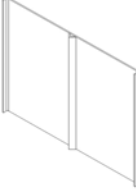
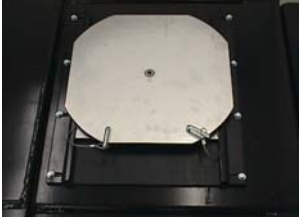
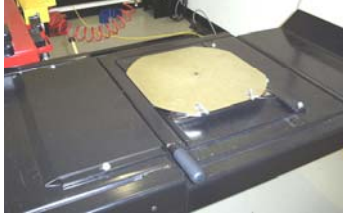

9.0 AVAILABLE ACCESSORIES

Hydraulic Jack Beams			
	Premium Air / Hydraulic Jack Beam		Standard Air / Hydraulic Jack Beam
4500 lb, 6000 lb, 7000 lb		6000 lb, 7000 lb	
Other Accessories			
	Drive-On Ramp Extension for Low Profile Vehicle (set of 2)		Air Outlet Kit (Factory Installed)
	Sliding Waste Collection Oil Tank 26 gal.		Drive-thru Kit (Quad Rack)
	Front Turning Radius Plates (set of 2)		Alignment Pan Cover, 4-Post
	Stainless Steel Turnplates		Rollback Kit (for Stainless Steel Turnplates)
	Air / Electric Service Station for 2-Post & 4-Post		Rear Slip Plate Refurb Kit - Stainless Steel Base (24" Decks Only - set of 2)
NO PICTURE AVAILABLE	Roll Forward Kit (4-Post)		Tsunami Kit (in-line compressed air dryer)

Accessories may not be available for all models. Contact supplier for availability and part numbers.