

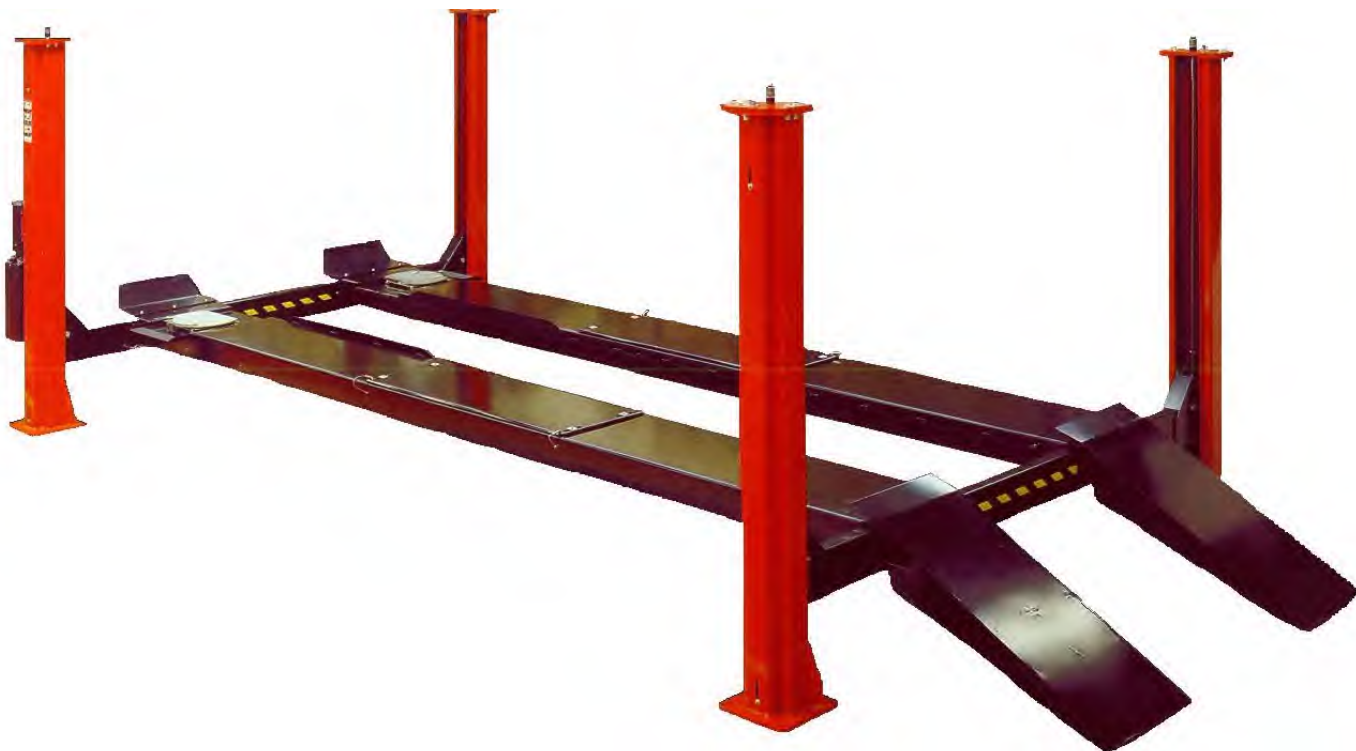

a division of **Snap-on Equipment**

INSTALLATION and OPERATION MANUAL



**READ THIS INSTRUCTION MANUAL THOROUGHLY
BEFORE INSTALLING, OPERATING, SERVICING OR
MAINTAINING THE LIFT. SAVE THIS MANUAL.**

**4-POST 18,000LBS
MODEL: ALIGNMENT FPA18210
SERVICE FPF18210**



309 Exchange Avenue • Conway, AR 72032
(800) 251-4500 • (501) 505-2662
Fax (501) 450-2085 • www.hofmann-usa.com



6500 Millcreek Drive • Mississauga, ONT L5N 2W6
(800) 267-2185
Fax (905) 821-2073 • www.hofmann.ca

TABLE OF CONTENTS	PAGE
1.0 Owner / Employer Obligations	4
2.0 IMPORTANT SAFETY INSTRUCTIONS	5
2.1 Safety Warning Labels	8
3.0 GENERAL SPECIFICATION	9
3.1 Service & Alignment Wheelbase Specification.....	10
4.0 INSTALLATION REQUIREMENTS & TOOLS	10
4.1 Foundation	10
4.2 Tools	10
5.0 CONTENTS.....	11
6.0 BAY LAYOUT	12
6.1 Typical Bay Layout.....	13
6.2 Chalk Line Layout.....	14
6.3 Identification of Components.....	16
7.0 INSTALLATION INSTRUCTIONS	17
7.1 Assembly of Cables to Left Side Deck	17
7.2 Assembly of Front & Rear Crossmember.....	22
7.3 Tower Assembly.....	24
7.4 Installation of towers.....	25
7.5 cable to tower installation	26
7.6 Power Pack Installation	27
7.7 Hydraulic Installation	28
7.8 Air Installations	29
7.9 Electrical Connections.....	30
7.10 Filter/Regulator/Lubricator Commisioning	31
7.11 Deck Leveling Procedure	33
7.11.1 Leveling Lift to Floor.....	33
7.11.2 Deck Leveling Procedure	33
7.12 Leveling on Safety Ladders.....	34
7.13 Anchor Installation.....	35
7.14 Accessory Installation.....	37
7.15 Final Check Of Assembled Lift.....	38
8.0 OPERATING INSTRUCTIONS	39
8.1 Operation Test With Vehicle	41
9.0 SAFETY AND OPERATING INSTRUCTIONS	41
10.0 RECOMMENDED INSPECTION AND MAINTENANCE	42
10.1 Lubrication Specifications.....	42
10.2 Maintenance Records	44
10.3 Wire Ropes	45
10.3.1 Wire Rope Conditions Guide	45
10.3.2 Wire Rope Replacement Criteria	46
10.3.3 Wire Rope Inspection	46

10.3.4	Wire Rope Lubrication	46
10.3.5	Wire Rope Adjustment	47
10.3.6	Inspect Cable Flange	47
10.4	Fasteners	47
10.5	Sheaves & Pins	47
10.5.1	Visual Inspection of Sheaves	47
10.5.2	Measure Sheave Wear	47
10.5.3	Sheave Pins	48
10.6	Mechanical Safety Latch (Dog)	48
10.7	Auxiliary Safety Mechanism	48
10.8	AirCylinders, Air Lines, Valves and Fittings	49
10.8.1	General Checks	49
10.8.2	Air Lubricator Oil Level	49
10.9	Hydraulic PowErpack and Hose	49
10.10	Hydraulic Cylinder	49
10.11	Runways	50
10.11.1	Check Runways	50
10.11.2	Inspect Jackbeam Tracks	50
10.12	Columns	50
10.12.1	Check Columns	50
10.12.2	Check Column Anchors	50
10.13	Approach Ramps, Chocks, Front Wheel Stops	51
10.14	Front and Rear Turn/Slip Plates	51
10.14.1	Visual Inspection	51
10.14.2	Clean Rear Slip Plates and Front Turn Tables	51
10.14.3	Maintenance of Rear Steer Plates	51
10.14.4	Maintenance of Rear Steer Plates - If Equipped with Plastic Bearing Cage	51
10.14.5	Anti-Skid Coating on Rear Steer Plates	52
10.15	Rolling Air Jacks	52
10.16	Entire Lift	52
11.0	LOCK OUT AND TAG OUT INSTRUCTIONS	52
11.1	Isolation and Verification Procedure:	54
11.2	Emergency Operation	55
12.0	PARTS LIST	57
12.1	Lift Assembly	57
12.2	Parts List – Lift Assembly	58
12.3	Tower Assembly	59
12.4	Parts List – Power Tower Assembly	60
12.5	Deck Assembly (Left Side)	61
12.6	Parts List – Deck Assembly (Left Side)	62
12.7	Crossmember Assembly	63
12.8	Parts List – Crossmember Assembly	64
12.9	Cylinder Assembly	65
12.10	Parts List – Cylinder Assembly	66
12.11	Hydraulic And Air Kit	67
12.12	Parts List – Hydraulic And Air Kit	68
12.13	Filter / Regulator / Lubricator Assembly	69
12.14	Cable Routing	70

12.15 Parts List – Cable Routing.....	71
12.16 Power Pack Assembly.....	72
12.17 Parts List – Power Pack.....	73
13.0 AVAILABLE ACCESSORIES.....	75

1.0 OWNER / EMPLOYER OBLIGATIONS

1. The Owner/Employer shall ensure that lift operators are qualified and that they are trained in the safe use and operation of the lift using the manufacturer’s operating instructions; ALI/SM 93-1, **ALI Lifting it Right safety manual**; ALI/ST-90 **ALI Safety Tips card**; ANSI/ALI ALOIM-2008, **American National Standard for Automotive Lifts - Safety Requirements for Operation, Inspection and Maintenance**; ALI/WL Series, **ALI Uniform Warning Label Decals/Placards**; and in the case of frame engaging lifts, ALI/LP-GUIDE, **Vehicle Lifting Points/Quick Reference Guide for Frame Engaging Lifts**.
2. The Owner/Employer shall establish procedures to periodically inspect the lift in accordance with the lift manufacturer’s instructions or ANSI/ALI ALOIM-2008, **American National Standard for Automotive Lifts - Safety Requirements for Operation, Inspection and Maintenance**; and the Employer shall ensure that the lift inspectors are qualified and that they are adequately trained in the inspection of the lift.
3. The Owner/Employer shall establish procedures to periodically maintain the lift in accordance with the lift manufacturer’s instructions or ANSI/ALI ALOIM-2008, **American National Standard for Automotive Lifts - Safety Requirements for Operation, Inspection and Maintenance**; and the Employer shall ensure that the lift maintenance personnel are qualified and that they are adequately trained in the maintenance of the lift.
4. The Owner/Employer shall maintain the periodic inspection and maintenance records recommended by the lift manufacturer’s instructions or ANSI/ALI ALOIM-2008, **American National Standard for Automotive Lifts - Safety Requirements for Operation, Inspection and Maintenance**.
5. The Owner/Employer shall display the lift manufacturer’s operating instructions; ALI/SM 93-1, **ALI Lifting it Right safety manual**; ALI/ST-90 **ALI Safety Tips card**; ANSI/ALI ALOIM-2008, **American National Standard for Automotive Lifts - Safety Requirements for Operation, Inspection and Maintenance**; ALI/WL Series, **ALI Uniform Warning Label Decals/Placards**; and in the case of frame engaging lifts, ALI/LP-GUIDE, **Vehicle Lifting Points/Quick Reference Guide for Frame Engaging Lifts** in a conspicuous location in the lift area convenient to the operator.
6. The Owner/Operator shall provide necessary lockout/tagout means for energy sources per ANSI Z244.1-1982 (R1993), **Safety Requirements for the**

Lockout/Tagout of Energy Sources, before beginning any lift repairs and maintenance.

7. The Owner/Employer shall not modify the lift in any manner without the prior written consent of the manufacturer.

⚠ WARNING DO NOT ATTEMPT TO OPERATE THIS LIFT IF ANY PART IS NOT WORKING PROPERLY OR YOU HAVE NOT READ THE COMPLETE OPERATING INSTRUCTION MANUAL.

2.0 IMPORTANT SAFETY INSTRUCTIONS

1. **When using this lift, basic safety precautions should always be followed, including the following:**
2. Read all instructions in this manual and on the lift thoroughly before installing, operating, servicing or maintaining the lift.
3. Care must be taken as burns can occur from touching hot parts.
4. Do not operate equipment with a damaged cord or if the equipment has been dropped or damaged – until it has been examined by a qualified service person.
5. Do not let a cord hang over the edge of the table, bench, or counter or come in contact with hot manifolds or moving fan blades.
6. If an extension cord is necessary, a cord with a current rating equal to or more than that of the equipment should be used. Cords rated for less current than the equipment may overheat. Care should be taken to arrange the cord so that it will not be tripped over or pulled.
7. Always unplug equipment from electrical outlet when not in use. Never use the cord to pull the plug from the outlet. Grasp plug and pull to disconnect.
8. Let equipment cool completely before putting away. Loop cord loosely around equipment when storing.
9. To reduce the risk of fire, do not operate equipment in the vicinity of open containers of flammable liquids (gasoline).
10. Adequate ventilation should be provided when working on operating internal combustion engines.
11. Keep hair, loose clothing, fingers, and all parts of body away from moving parts.

12. To reduce the risk of electric shock, do not use on wet surfaces or expose to rain.
13. Use only as described in this manual. Use only manufacturer's recommended attachments.
14. **ALWAYS PERSONAL PROTECTIVE EQUIPMENT.** Everyday eyeglasses only have impact resistant lenses, they are not safety glasses.
15. Inspect lift daily. Do not operate if it malfunctions or problems have been encountered.
16. Never attempt to overload the lift. The manufacturer's rated capacity is shown on the identification label on the power side column. Do not override the operating controls or the warranty will be void.
17. Before driving vehicle between the towers, position the arms to the drive-through position to ensure unobstructed clearance. Do not hit or run over arms as this could damage the lift and/or vehicle.
18. Only trained and authorized personnel should operate the lift. Do not allow customers or bystanders to operate the lift or be in the lift area.
19. Position the lift support pads to contact the vehicle manufacturer's recommended lifting points. Raise the lift until the pads contact the vehicle. Check pads for secure contact with the vehicle. Check all arm restraints and insure they are properly engaged. Raise the lift to the desired working height.
20. Some pickup trucks may require an optional truck adapter to clear running boards or other accessories.
21. **NOTE:** Always use all 4 arms to raise and support vehicle.
22. **Caution!** Never work under the lift unless the mechanical safety locks are engaged.
23. Note that the removal or installation of some vehicle parts may cause a critical load shift in the center of gravity and may cause the vehicle to become unstable. Refer to the vehicle manufacturer's service manual for recommended procedures.
24. Always keep the lift area free of obstruction and debris. Grease and oil spills should always be cleaned up immediately.
25. Never raise vehicle with passengers inside.
26. Before lowering check area for any obstructions.
27. Before removing the vehicle from the lift area, position the arms to the drive-thru position to prevent damage to the lift and /or vehicle.

28. **Do not** remove hydraulic fittings while under pressure.

For additional safety instructions regarding lifting, lift types, warning labels, preparing to lift, vehicle spotting, vehicle lifting, maintaining load stability, emergency procedures, vehicle lowering, lift limitations, lift maintenance, good shop practices, installation, operator training and owner/employer responsibilities, please refer to **“Lifting It Right” (ALI/SM) and “Safety Tips” (ALI/ST) and vehicle lift points for service garage lifting SAE J2184.**

For additional instruction on general requirements for lift operation, please refer to **“Automotive Lift-Safety Requirements For Operation, Inspection and Maintenance” (ANSI/ALI ALOIM).**

Installation shall be performed in accordance with ANSO/ALI ALIS, Safety Requirements for Installation and Service of Automotive Lifts.



ATTENTION! This lift is intended for indoor installation only. It is prohibited to install this product outdoors. Operating environment temperature range should be 41 – 104 °F (5 – 40 °C). Failure to adhere will result in decertification, loss of warranty, and possible damage to the equipment.

+ 070126-Quadra-WLSIA01

SAFETY INSTRUCTIONS

If attachments, accessories or configuration modifying components that are located in the load path, affect operation of the lift, affect the lift electrical listing or affect intended vehicle accommodation are used on this lift and, if they are not certified for use on this lift, then the certification of this lift shall become null and void. Contact the participant for information pertaining to certified attachments, accessories or configuration modifying components.

www.autolift.org

©2007 by ALI, Inc.

ALI / WLSIA01

SAVE THESE INSTRUCTIONS

2.1 SAFETY WARNING LABELS

Automotive Lift Institute, Inc.

⚠ CAUTION	⚠ CAUTION
Lift to be used by trained operator ONLY.	Authorized personnel only in lift area.

The messages and pictographs shown are generic in nature and are meant to generally represent hazards common to all automotive lifts regardless of specific style.

Funding for the development and validation of these labels was provided by the Automotive Lift Institute, PO Box 85 Cortland, NY 13045.

Replacement label sets may be obtained from the original lift manufacturer and ALI's member companies. They are protected by copyright.
www.autolift.org © 2009 by ALI, Inc. ALI/WL200c

NOTICE	NOTICE
Read operating and safety manuals before using lift.	Proper maintenance and inspection is necessary for safe operation.

NOTICE	<p>The messages and pictographs shown are generic in nature and are meant to generally represent hazards common to all automotive lifts regardless of specific style.</p> <p>Funding for the development and validation of these labels was provided by the Automotive Lift Institute, PO Box 85 Cortland, NY 13045.</p> <p>Replacement label sets may be obtained from the original lift manufacturer and ALI's member companies. They are protected by copyright. www.autolift.org © 2009 by ALI, Inc. ALI/WL200s</p>
Do not operate a damaged lift.	

WL200 Series Label Kit

⚠ WARNING	⚠ WARNING
Clear area if vehicle is in danger of falling.	Remain clear of lift when raising or lowering vehicle.

⚠ WARNING	⚠ WARNING
Keep clear of pinch points when lift is moving.	Keep feet clear of lift while lowering.

⚠ WARNING	⚠ WARNING
Do not override self-closing lift controls.	Chock wheel to prevent vehicle movement.

The messages and pictographs shown are generic in nature and are meant to generally represent hazards common to all automotive lifts regardless of specific style.

Funding for the development and validation of these labels was provided by the Automotive Lift Institute, PO Box 85 Cortland, NY 13045.

Replacement label sets may be obtained from the original lift manufacturer and ALI's member companies. They are protected by copyright.
www.autolift.org © 2010 by ALI, Inc. ALI/WL200w

SAVE THESE INSTRUCTIONS

3.0 GENERAL SPECIFICATION

Maximum Capacity	18,000 lb	8165 kg
Maximum Wheelbase – General Service	220"	5588 mm
Maximum Wheelbase – 2-Wheel Alignment	203"	5156 mm
Maximum Wheelbase – 4-Wheel Alignment	144"	3658 mm
Minimum Wheelbase – 4-Wheel Alignment	86"	2184 mm
Overall Length	303-3/8"	7706 mm
Overall Width	152-1/8"	3864 mm
Lowered Runway Height	9-1/2"	241 mm
Maximum Lifting Height (to runway surface)	72"	1829 mm
Rise Time	70 Seconds	
Ramp approach angle (no shims)	10°	
Power Requirements	230VAC, 1PH., 20A, 60 Hz	
Shipping Weight	5465 lb	2484 kg
Maximum Operating Pressure (Full Load):	2650 psi	183 bar
Air Supply Requirements:	90 - 120 psi	6 - 8 bar

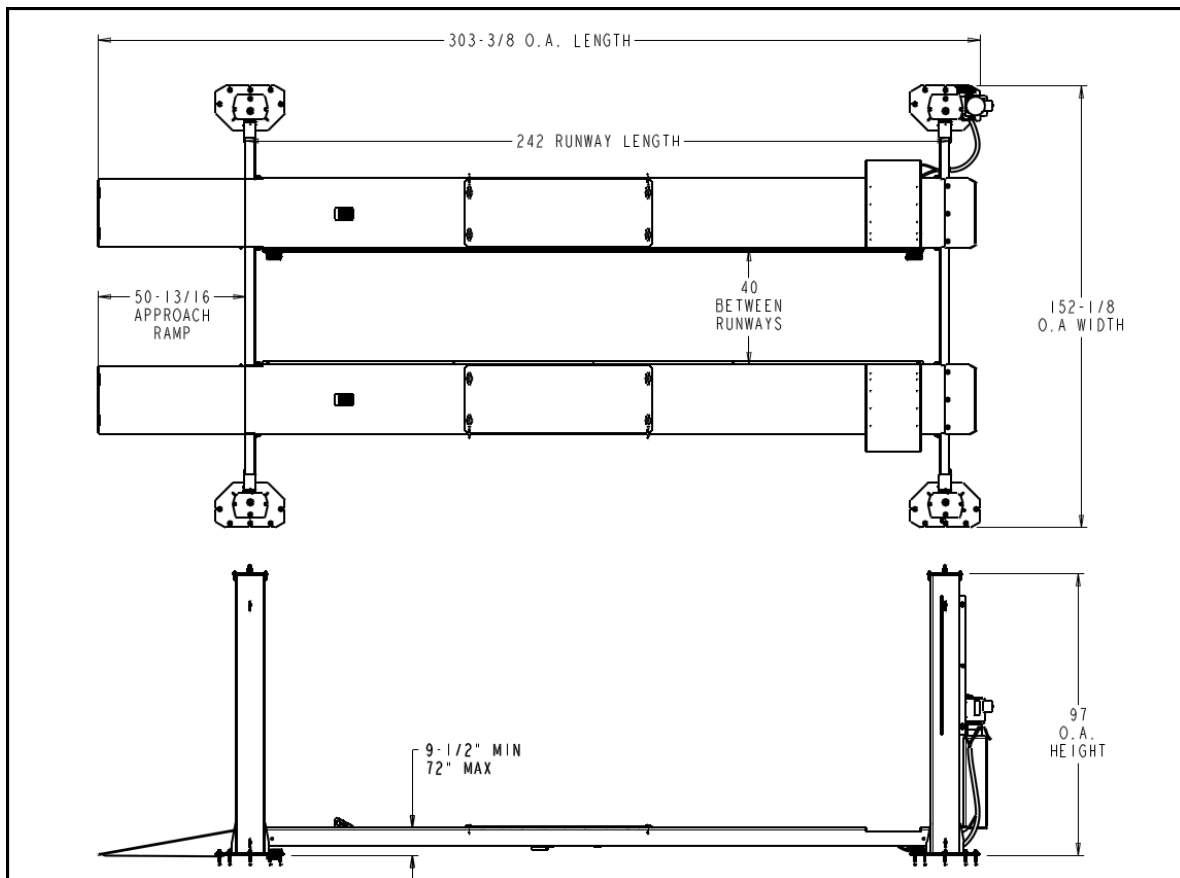
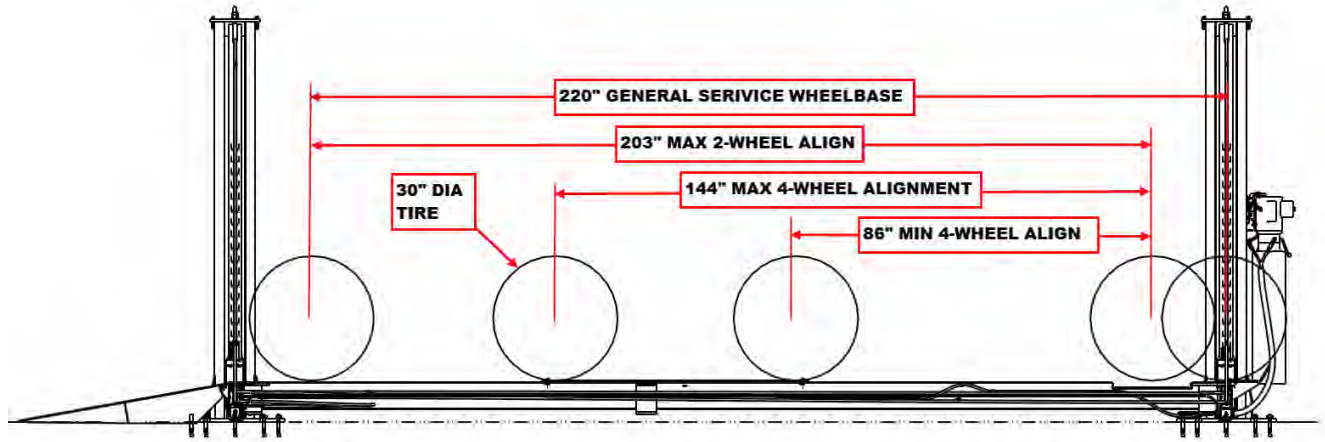

Figure 1 - General Specifications

3.1 SERVICE & ALIGNMENT WHEELBASE SPECIFICATION



4.0 INSTALLATION REQUIREMENTS & TOOLS

4.1 FOUNDATION

It is the user's responsibility to provide a satisfactory installation area for the lift. Lifts should only be installed on level concrete floors with a minimum thickness of six inches (6") or 152 mm. Concrete must have a minimum strength of 4000 psi or 28 MPa and should be aged thirty (30) days prior to installation. Please consult with an architect, contractor or engineer if doubt exists as to the strength and feasibility of the floor to enable proper lift installation and operation.

A qualified person should be consulted to address seismic loads and other local or state requirements.

It is the user's responsibility to provide all wiring for electrical hook-up prior to installation and to insure that the electrical installation conforms to local building codes. Where required, it is the user's responsibility to provide an electrical isolation switch located in close proximity to the lift that will enable emergency stop capability and isolate electrical power from the lift for any servicing requirements.

4.2 TOOLS

- ROTARY HAMMER DRILL
- 3/4" CONCRETE DRILL BIT
- SELF LEVELING LASER OR 4' LEVEL
- HAMMER (for anchor installation)
- PRY BAR (for shim installation)
- CHALK LINE (lift location)
- TAPE MEASURE
- ELECTRICAL TAPE

- STEP LADDER (adjusting cables and/or safety ladder in posts)
- SIDE CUTTERS (for cutting shipping straps)
- (8) JACK STANDS (set up)
- STANDARD SOCKETS AND WRENCHES
- ALLAN KEY SET
- SCREWDRIVER SET
- FLOOR JACK OR ENGINE HOIST
- BOX CUTTER / SNIPS (to remove packaging)
- RUBBER OR PLASTIC MALLET

5.0 CONTENTS

The lift is packaged to protect it from any damage that may occur during shipping. The two deck assemblies and crossmembers are packaged together with the accessory boxes strapped to them.

Main Structural Components:

- 1 - Left Side Deck Assembly (complete with hydraulic cylinder, sheaves and cables)
- 1 - Right Side Deck Assembly
- 1 - Front Crossmember Assembly (with air cylinder release locks and sheaves)
- 1 - Rear Crossmember Assembly (with air cylinder release locks and sheaves)

Accessory Box Components

Box 1 Contents:

- 1 - Power Post (with safety ladder)
- 3 - Post (with safety ladder)

Box 2 Contents:

- 1 - Hardware Kit (with separate packaging list)
- 2 - Ramp pin
- 2 - Front Wheel Stop
- 4 - Sheave Cover
- 2 - Approach Ramp
- 1 - Coupler, 1/4" NPT
- 2 - Recoil Hose
- 1 - Power Unit 220v/1Ph/3hp
- 10ft - 1/4" DIA. Polytube
- 10ft - 3/8" DIA. Polytube
- 1 - Hose Guard
- 1 - Hydraulic Hose Assembly (16ft. lg.)
- 2 - Cable Tie
- 1 - Air Valve & Filter Assembly
- 1 - Flow Control
- 1 - Installation & Operation Manual
- 1 - Lift it Right Manual "ALI"
- 1 - Lift it Right Safety Tips

- 1 - "ALI" Standards
- 1 - "ALI" Quick Reference Guide
- 8 - Glide Bearing
- 4 - Lifting cables

6.0 BAY LAYOUT

PLEASE TAKE THE TIME TO READ THESE INSTRUCTIONS COMPLETELY. A QUICK CHECK OF THE CONTENTS OF THE ACCESSORY BOX WOULD ALSO DECREASE THE INSTALLATION TIME.

1. Gather the tools and materials required for the installation.
2. Select the location best suited for your lift.

NOTE: In determining lift area check for the following:

- Ease of driving a vehicle on and off the lift.
- Overhead obstructions, low ceiling height, overhead doors, overhead heaters etc.
- Floor obstructions, uneven floor in lift area, floor drains, work benches, electrical wiring in floor, etc.
- Anchor locations must be a minimum of 6" from any cracks
- An outline matching the dimensions shown in **Figure 2** will need to be marked on the floor. Refer to **Figure 3** for outline dimensions. Refer to General Lift Specifications for overall lift dimensions.
- Recommended minimum clearance around the lift is three (3) feet. Ensure clearance conforms to local building and fire codes.
- Recommended overhead clearance is a minimum twelve (12) foot ceiling providing 6 feet for the maximum lift height and 6 feet for the supported vehicle. For vehicles taller than 6 feet it is recommended that the user provides additional overhead clearance or a shut off mechanism to stop the lift from raising the vehicle too high.

⚠ WARNING **DO NOT** install the lift on asphalt or other unstable surfaces. Lift columns are supported only by anchors in floor.

INSTALLER: PLEASE RETURN THIS BOOKLET TO LIFT OWNER/OPERATOR AFTER COMPLETING INSTALLATION

6.1 TYPICAL BAY LAYOUT

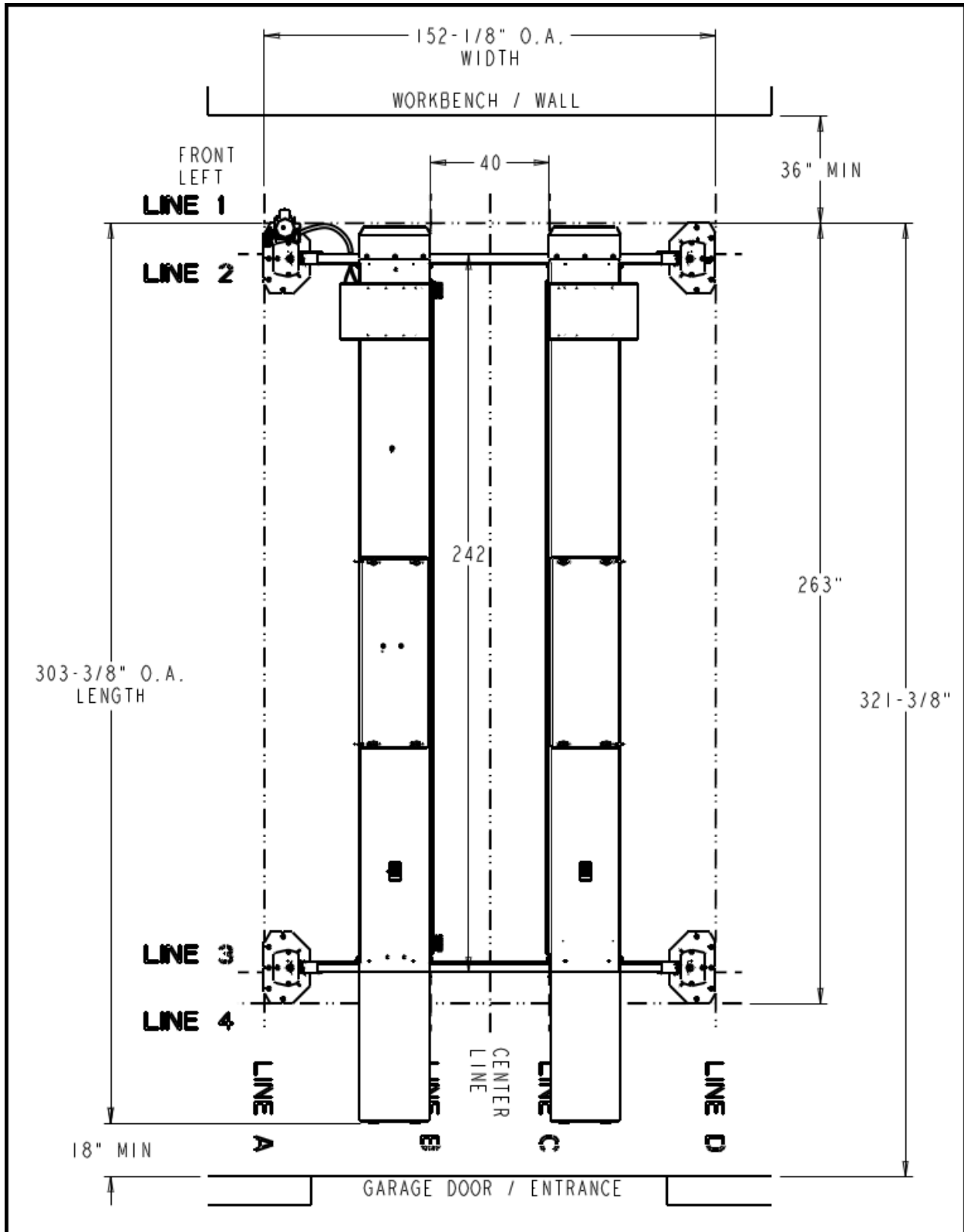

Figure 2 - Typical Bay Layout

6.2 CHALK LINE LAYOUT

WARNING

None of the anchors shall be closer than **4-3/4"** to any edge of a concrete slab, expansion joint or crack in the garage floor. Review position of front towers, base plates and anchors, and relocate lines "1", "A", "D" if needed.

1. **Refer to Figure 2 & 3.** Make a chalk line parallel to the doorway at least 321-3/8" in from the doorway. This will be the location for the front face of the tower baseplate. Call this line "1".
2. Determine the center of the doorway and bay. Make a centerline to intersect with line "1".
3. Make a chalk line parallel to line "1", 263" back toward the door. Call this line "4".
4. Make a chalk line parallel to line "1", 10-1/2" towards door. Call this line "2".
5. Make a chalk line parallel to line "4", 10-1/2" towards front. Call this line "3".
 - Lines "2" and "3" will be the lines that the front and rear of the runways align to.
6. Make a chalk line parallel to the center line 76-1/16" to the left side and intersecting line "1" and line "4". Call this line "A".
7. Make a chalk line parallel to line "A" 152-1/8" to the right, intersecting lines "1" and "4". Call this line "D".
 - Lines "A" & "D" and "1" & "2" will be the lines that the outside edge of the tower baseplates align to.
8. Make two chalk lines spaced 20" to the left and right side of the centerline intersecting line "1" and line "4". Call these lines, line "B" & "C".
 - Lines "B" & "C" will be the lines that the inside edge of the runways align to.

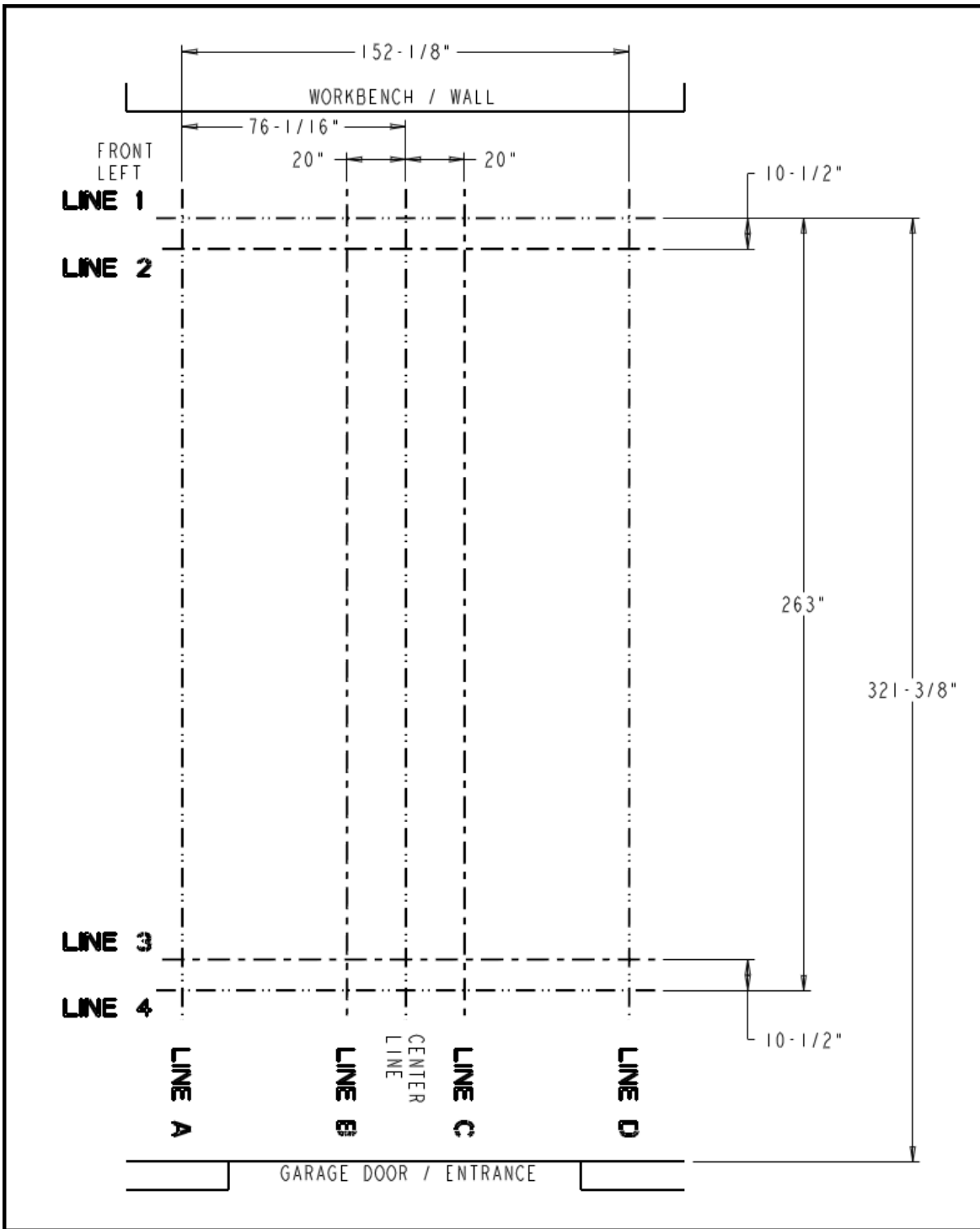

Figure 3 - Chalk line layout

6.3 IDENTIFICATION OF COMPONENTS

1. Identify and unpack major lift components (Towers, Crossmembers & Runways) and place them where they belong according **Figure 1**.

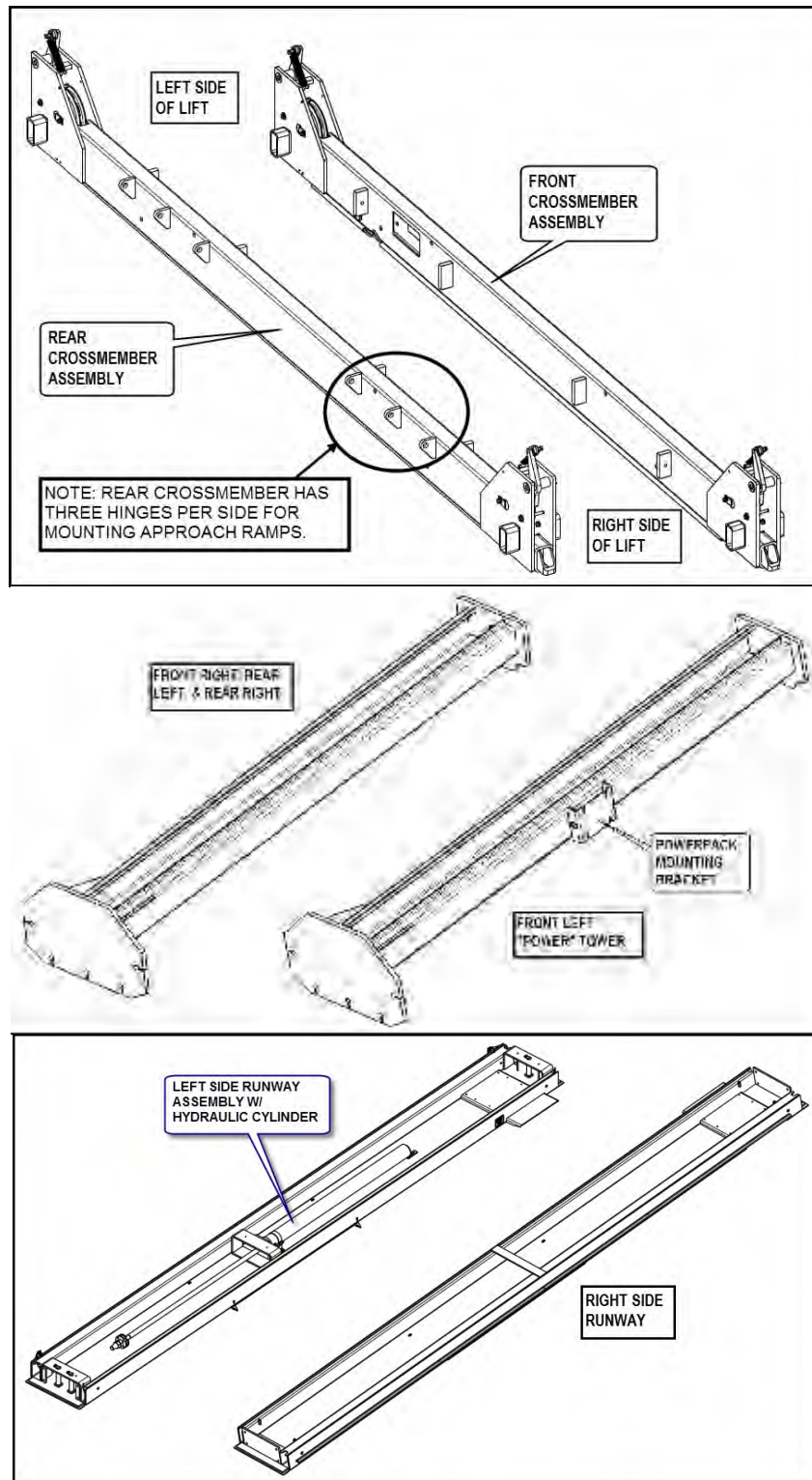

Figure 4. Component Identification

2. Locate and identify the coiled cables as follows, place close to the rear of the left side of the chalk outlines. **(Table 2):**

Cable P/N	Location	Length
2-1360	Front Left	407.5"
2-1361	Front Right	473.5"
2-1362	Rear Left	162"
2-1363	Rear Right	228"

Table 2: Cable Identification

7.0 INSTALLATION INSTRUCTIONS

7.1 ASSEMBLY OF CABLES TO LEFT SIDE DECK

1. Place the left deck assembly so that the inside edge lies along chalk line "B".
2. Place the right deck assembly so that the inside edge lies along chalk line "C".
3. Position both decks so that the front edge lies along chalk line "2".
4. Using a floor jack or engine hoist, lift the left side runway and support with (4) jack stands **(see Figure 5)** or other means of support. Use the floor jack or engine hoist as addition support.
5. If possible, repeat for right side deck.



Figure 5: LS Deck Support

NOTE: THE CYLINDER ROD MUST BE FULLY EXTENDED IN ORDER TO ATTACH THE NON-THREADED ENDS (SLEEVES) OF THE CABLES TO THE CABLE FLANGE ON CYLINDER ROD. USE COMPRESSED AIR IN THE SHOP AND AN AIR NOZZLE AT THE BREATHER END TO EXTEND THE CYLINDER ROD. USE CAUTION AND PROTECTIVE EQUIPMENT WHEN WORKING WITH COMPRESSED AIR.

6. Loosen the hose clamp on the cable flange and assemble the studded end of each cable to the flange as shown in **Figure 6**. Ensure the cable studs are seated properly in the counterbore. Tighten the hose clamp.

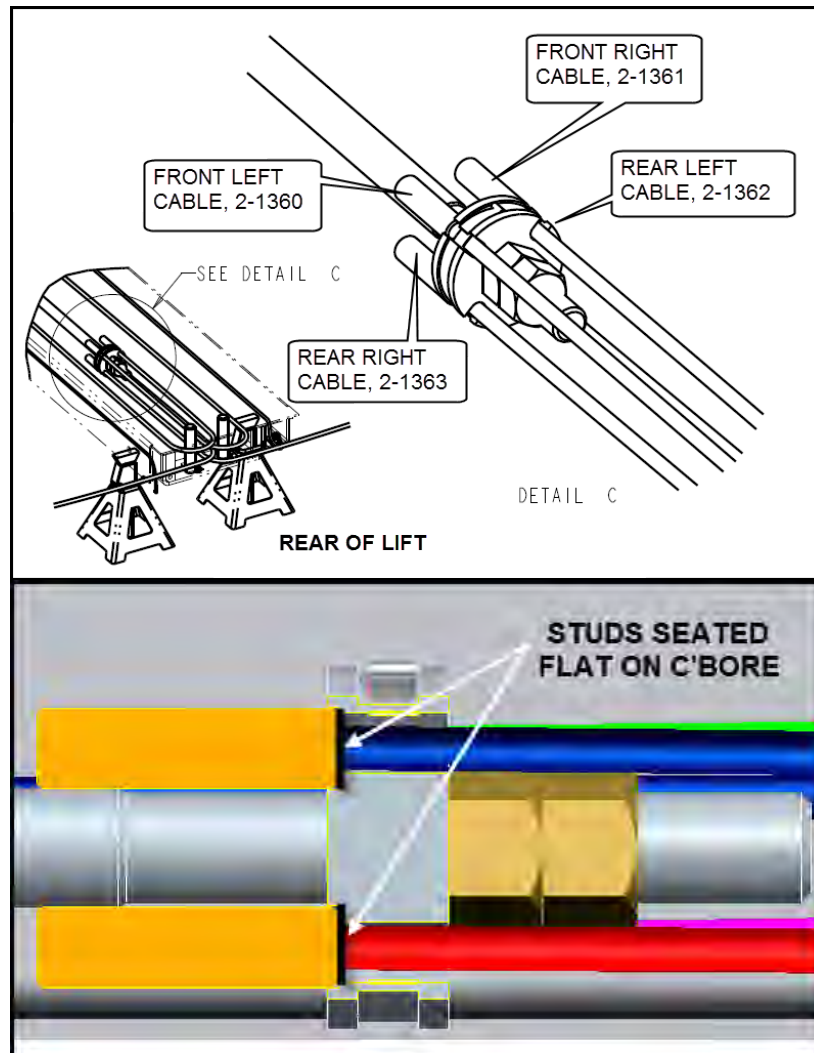

Figure 6. Cable Flange and Cable Assembly

7. Use **Figure 7** as reference during the rear pulley stack and cable assembly. Each cable will enter the pulley stack in the middle of the runway and wrap around the pulley 90 degree (for rear) or 180 degrees (for front).
8. Remove the pulley pins and hardware from rear of runway.
9. Referring to **Figure 7** and **Figure 8**, assemble the left side of the pulley stack, as shown, with cables 2-1363 & 2-1360 starting from the bottom of the stack and working to the top.

- Assemble lower thrust washer and pulley and reinstall the pulley pin to hold these in place.
- Assemble four more thrust washers (as shown) and the top pulley with front left cable 2-1360 wrapped around the pulley. Push pulley pin further up to hold these in place.
- Install remaining thrust washers and 1" spacer then complete assembly of pulley pin and lock in place with hardware.
- Install rear right cable 2-1363 around the lower pulley.

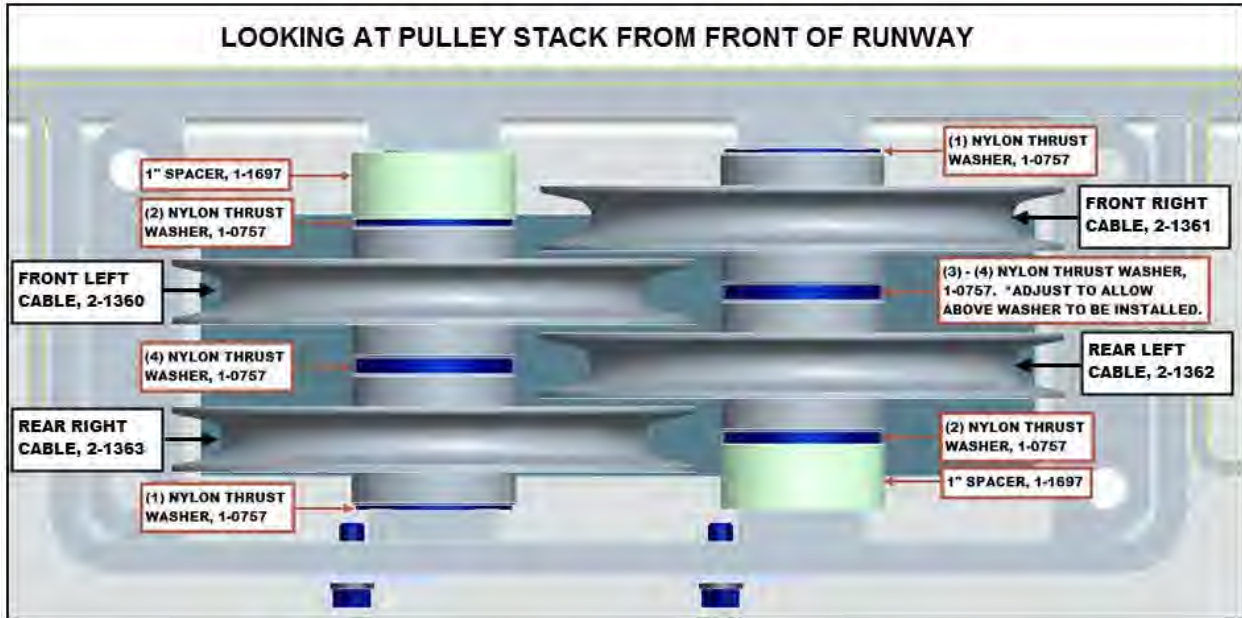

Figure 7. Rear Pulley Stack Assembly

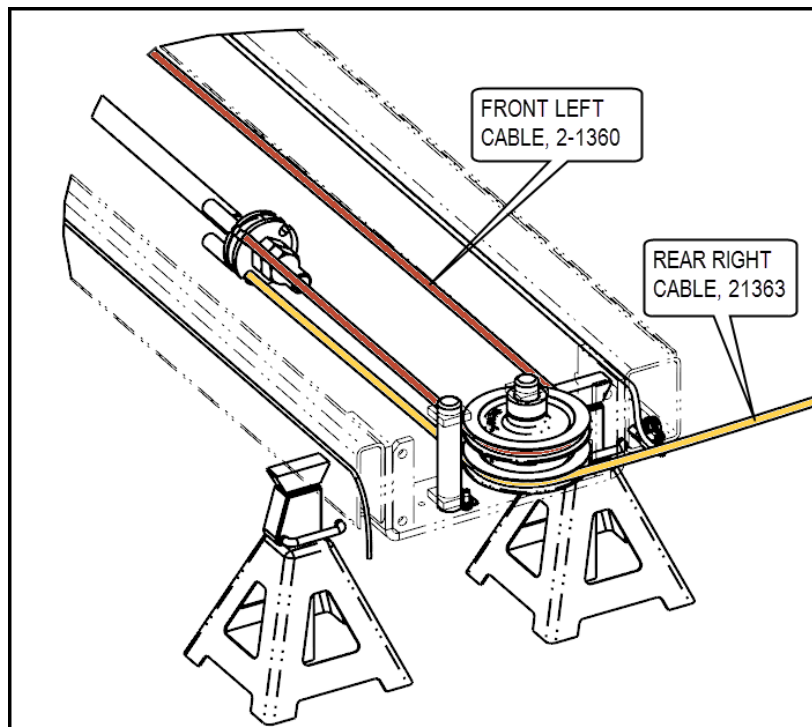

Figure 8. Front Left and Rear Right Cable Installed at Rear

10. Referring to **Figure 7** and **Figure 9**, assemble the right side of the pulley stack, as shown, with cables 2-1362 & 2-1361.

- Pass the rear left cable 2-1362 between the two pulleys on the left side (shown above).
- Starting from the bottom right side of the pulley stack, assemble the 1" spacer, lower thrust washers and pulley. Reinstall the pulley pin to hold these in place. Wrap around the front right cable 2-1362 on to the pulley.
- Assemble four thrust washers as shown and the top pulley with front right cable 2-1361 wrapped around the pulley. Push pulley pin further up to hold these in place.
- Add remaining single thrust washer and complete installation of pulley pin and hardware to secure.

Note: If top thrust washer does not fit, remove one thrust washer from middle of assembly.

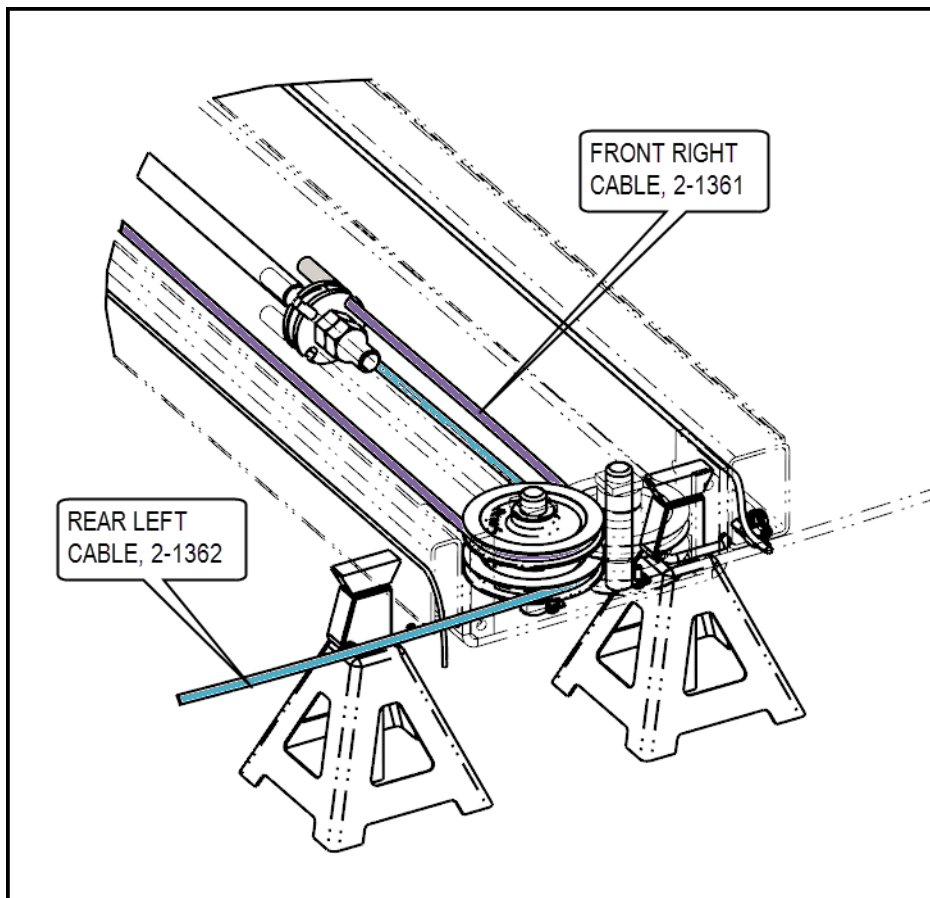

Figure 9. Front Right and Rear Left Cable Installed at Rear

11. Use **Figure 10** as reference during the front pulley stack and cable assembly.

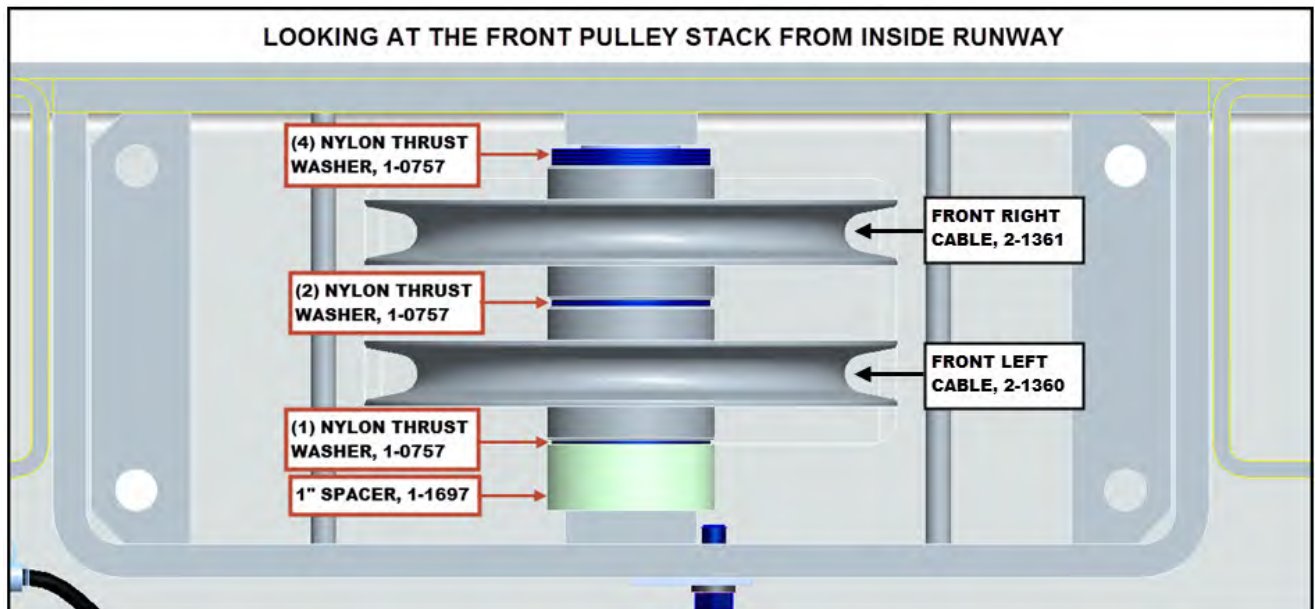

Figure 10. Front Pulley Stack Assembly

12. Remove the pulley pin and hardware from front of runway.

13. Referring to **Figure 10** and **Figure 11**, assemble the pulley stack with cables as shown.

- Assemble lower thrust washer and spacer. Insert pulley pin to hold these in place. Leave 1" of the pulley pin exposed above thrust washer.
- Wrap the front left cable 2-1360 around pulley and insert onto pulley pin. Push pulley pin further up to hold these in place.
- Install two more thrust washers.
- Wrap the front right cable 2-1361 around pulley and align with rest of assembly. Push pulley pin further up to hold these in place.
- install four thrust washers and complete the installation of the pulley. Secure with hardware.

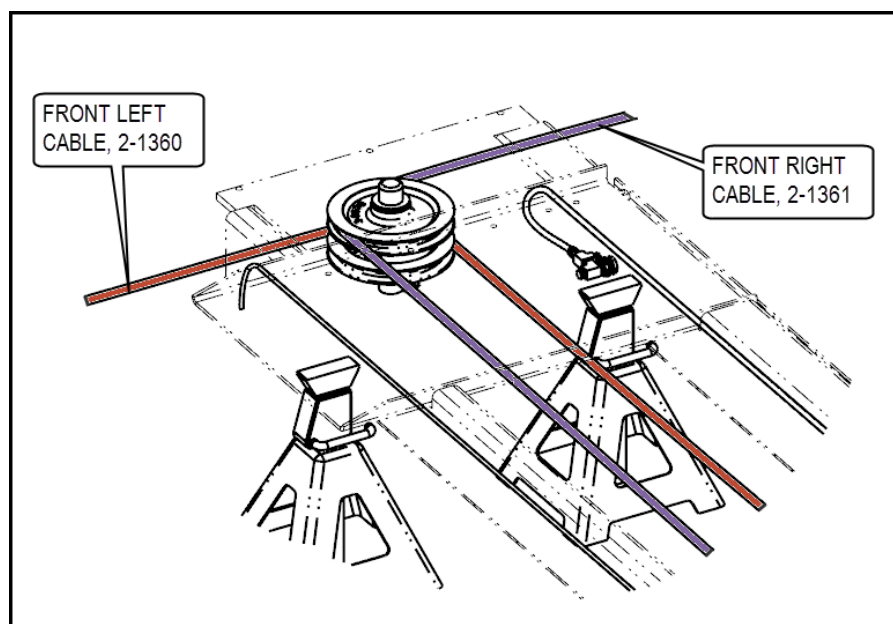

Figure 11. Front Right and Rear Left Cable Installed at Front

7.2 ASSEMBLY OF FRONT & REAR CROSSMEMBER

1. Move the front crossmember and rear crossmembers into position. Do not assemble yet. Refer to **Figure 4** to identify the front and rear crossmembers.
2. Starting at the front pulley stack assembly, route the front cables thru the window in the front crossmember and out past the safety locks on each side of the crossmember. **Figure 12**.

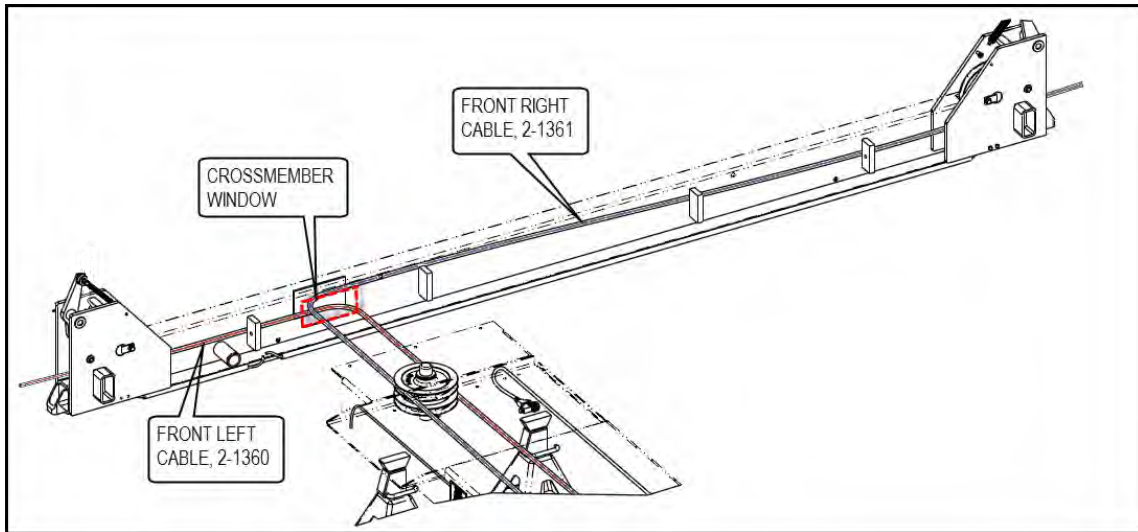
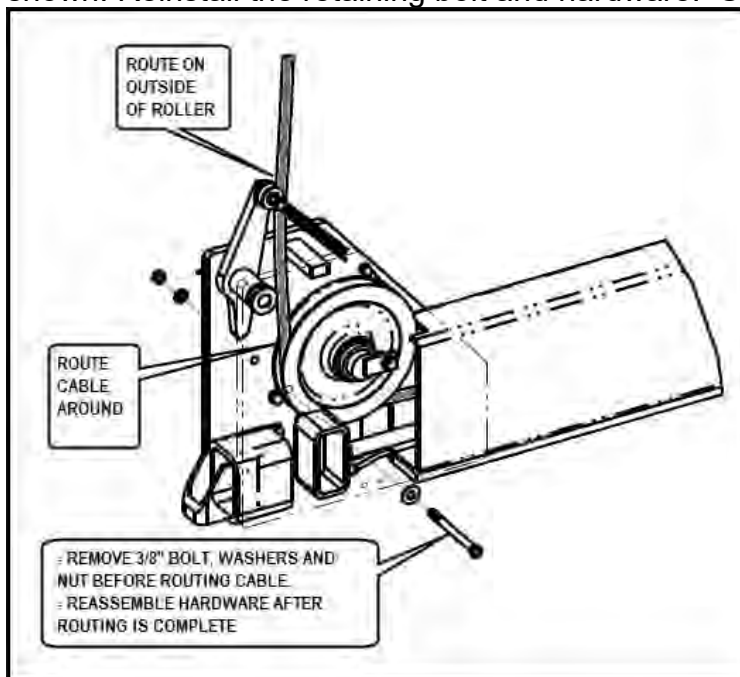

Figure 12. Front Right and Left Cable Installed in Crossmember

3. At the end of each crossmember, remove the 3/8" cable retaining bolt and hardware.
4. Route the cable around the pulley then around the auxiliary safety pulley as shown. Reinstall the retaining bolt and hardware. See **Figure 13**.



NOTE: Ensure retaining bolt is installed behind cable, not between cable and ..

Figure 13. Front Right and Left Cable Installed in Crossmember

- Using a floor jack or engine hoist, raise the front crossmember up to the level of the decks and attach it using the $\frac{1}{2}$ " DIA x $4\frac{1}{2}$ " LG hex bolts, $\frac{1}{2}$ " flat washers, $\frac{1}{2}$ " lock washers and $\frac{1}{2}$ " hex nuts found in the polybag labeled "E" (Decks).

CAUTION The cables running inside the crossmember must pass between the $\frac{1}{2}$ "x $4\frac{1}{2}$ " long bolts used to fasten the crossmember to the deck assemblies. See Figure 14.

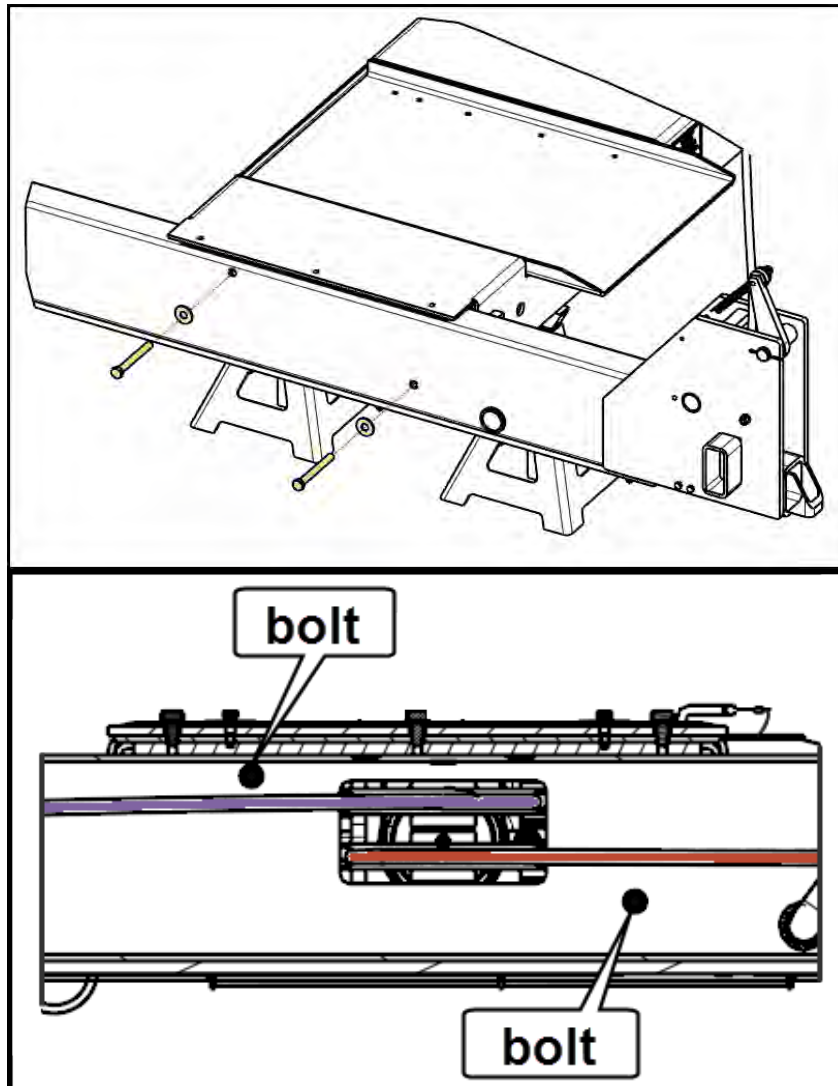

Figure 14. Fastening Crossmember to Deck

- Repeat the previous steps for the rear crossmember.
- Using floor jack(s) and/or engine hoist(s), move the (4) jack stands from under the left side deck to each corner on the crossmember. **Figure 15**

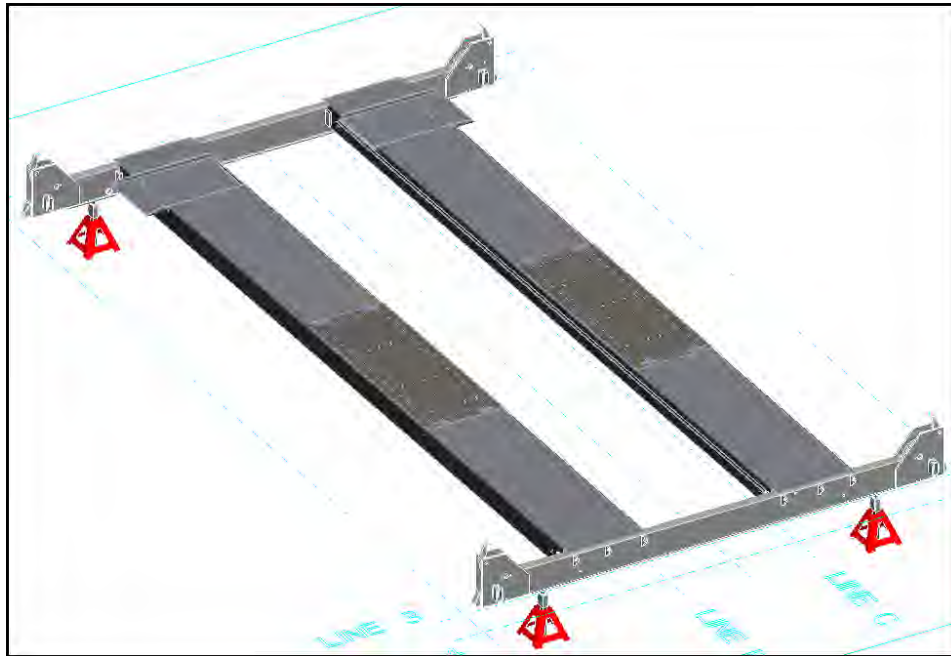

Figure 15. Jack Stand setup on Crossmembers

8. Assemble right side deck assembly to front and rear crossmembers.
9. At this point the decks should be completely fastened to the crossmembers and the threaded portion of each cable should be routed through the crossmembers, past the lock safety.

Before proceeding, check that the layout matches that shown in Figure 3, that the lift is square and that there is a 40" gap between the decks along their entire length. This dimension is critical as it is necessary to allow the jackbeams to roll freely.

7.3 TOWER ASSEMBLY

1. Each tower will have a safety ladder and hardware packaged inside. See **Section 12.3 Tower Assembly** in parts list.
2. Remove the safety ladder from tower, then remove the hardware from the top and back of the ladder.
3. Insert the safety ladder into the top plate hole furthest to back of the column. Keep in place by assembling the 3/4" flat washer and two 5/8" nuts.
4. At the back of the tower, align the holes in safety ladder mounting blocks to the slots on the tower and assemble the 3/8" hardware.
5. Do not tighten hardware at this time as adjustments to the ladder position will be required later.
6. Repeat for remaining tower assemblies.

7.4 INSTALLATION OF TOWERS

1. Remove the slider block weldments from both crossmembers by removing the 3/8"-16UNC x 1"LG Hex HD Bolts and 3/8" lock washers attaching them to the crossmember. See **Figure 16**.
2. Determine which tower is the power post (see **Figure 4**) and position it in the front left corner. Position the remaining three towers at the other corners of the lift.
3. Slide each tower around the crossmember so that the holes for attaching the slider blocks are roughly halfway inside the channel.

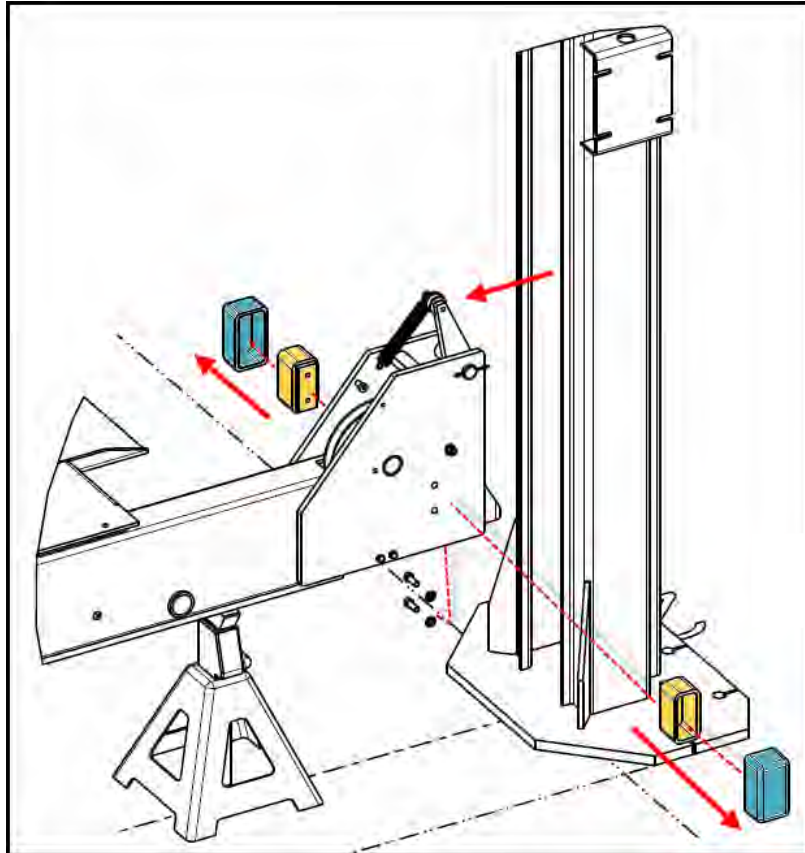

Figure 16. Tower Installation

4. Place the Glide Bearings (located in the accessory box) on the slider block weldments and bolt the slider block weldments back onto the crossmember using the 3/8"-16UNC x 1"LG Hex HD Bolts and 3/8" lock washers removed previously.
5. Pull the towers backwards (away from the decks) so that the slider blocks are contacting the inside of the tower.
6. Repeat for remaining towers.

7.5 CABLE TO TOWER INSTALLATION

1. Assemble each cable to the top plate of their respective towers. Secure in place with 7/8" washer and two 7/8" hex nuts. See **Figure 17**.

Note: During leveling of the lift (see **Section 6.11**), optional 1" and 2" spacers have been included to allow for more adjustment.

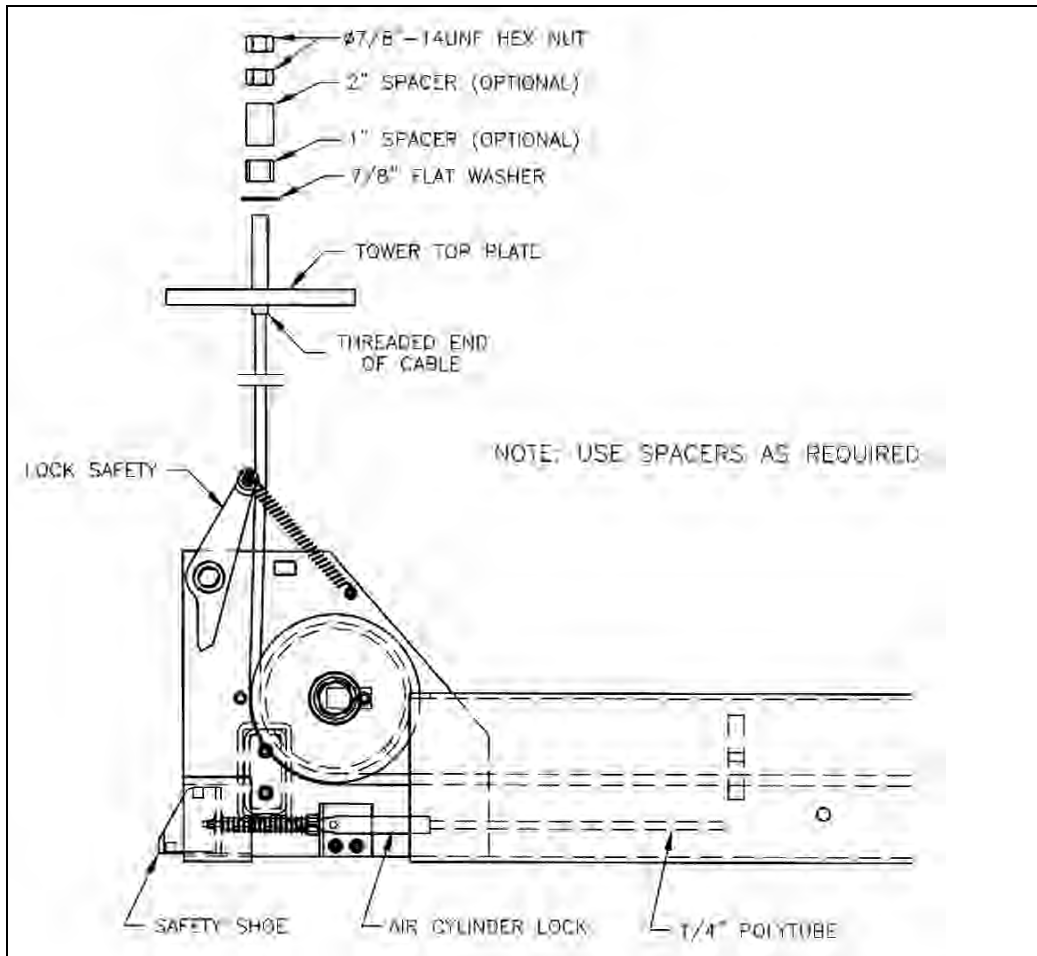

7.6 POWER PACK INSTALLATION

NOTE: When working with hydraulic lines and valves, it is important to keep all components clean and free of dirt.

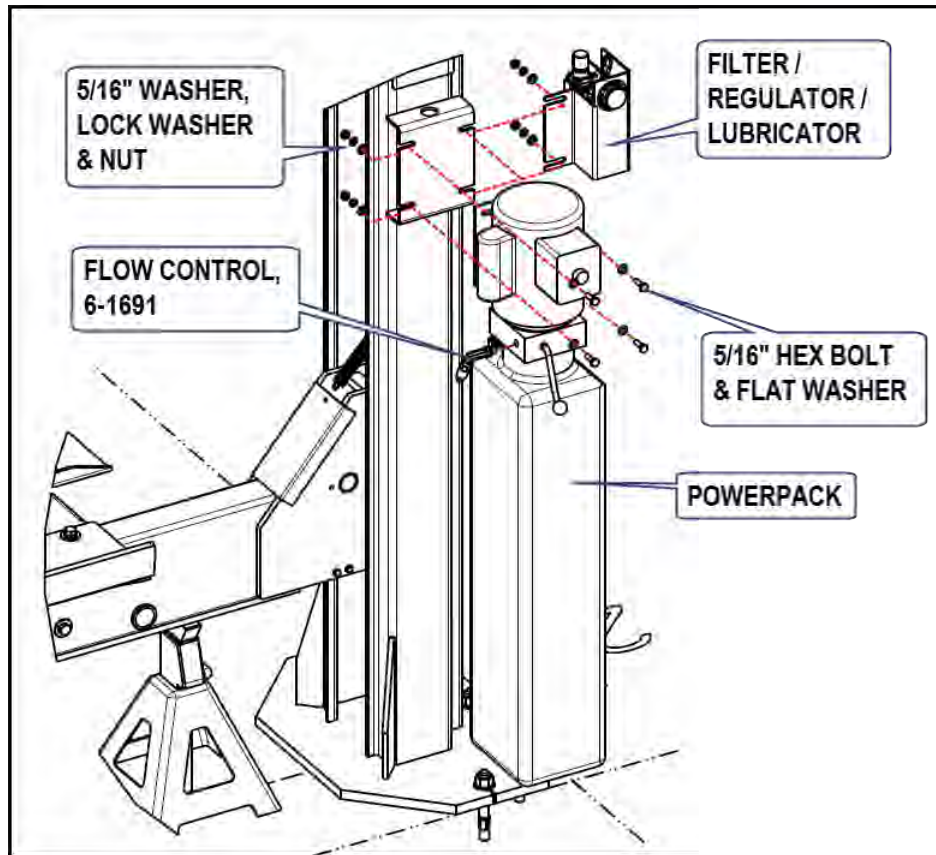

Figure 18. Powerpack Install

1. Locate Powerpack and Filter/Regulator/Lubricator (FRL) assembly inside the accessory box. Gather the 5/16" hardware located in "Polybag D" inside the hardware kit
2. Mount the power pack to the mounting bracket on the front face of the left front post using the 5/16"-18UNC × 1"LG. hex head bolts and 5/16" washers, lockwashers and hex head bolts.
3. Tighten up the hardware on the left side of the powerpack and leave the right side hardware loose.
4. Slide the FRL between the inside of the mounting bracket and the inside flat washers. Tighten all hardware.



Figure 19. FRL Install

7.7 HYDRAULIC INSTALLATION

1. Locate the supply lines: 1/4" and 3/8" polytube (10ft.), 3/8" flexible hydraulic line (16ft.), and install the hose guard to cover all three lines. All four items are found in the accessory box

TIP: Tape one end of the hydraulic hose to the two polytubes and feed them through the hose guard. Remove tape once completed.

2. Install Flow Control #6-1691 into powerpack. See **Figure 18**.
3. Feed the hose guard through the opening on the front left crossmember assembly.
4. Connect the end of the flexible hydraulic hose (3/8" JIC, F SWIVEL) to the fitting at the cylinder. **DO NOT OVER TIGHTEN**. Use the two supplied zip ties to attached the hose to the cylinder body.
5. Connect the other end of the flexible hydraulic hose (3/8" JIC, F SWIVEL) to the flow control on the powerpack.

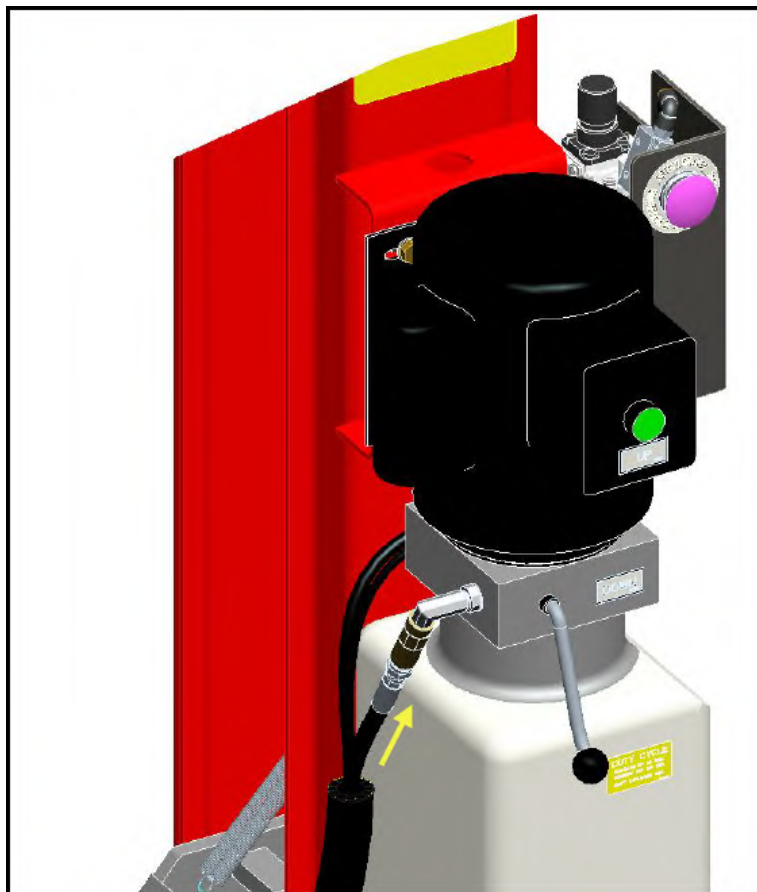

Figure 20. Powerpack Install

7.8 AIR INSTALLATIONS

NOTE: When cutting polytube, be sure to cut the line at 90 degrees. Failure to do so may result in leaks in the air connections.

1. Locate the 1/4" polytube cross and tee fitting in polybag "C" in hardware kit.
2. Connect the 1/4" polytube from the hose guard (i.e. supply line) to the 1/4" pushlock cross at the front of the left side deck assembly. Connect the opposite end to the FRL assembly. **See figure 21 & 23.**
3. At the rear of the lift, connect the 1/4" polytube from the deck to the crossmember polytubes using the tee fitting. **See figure 21.**

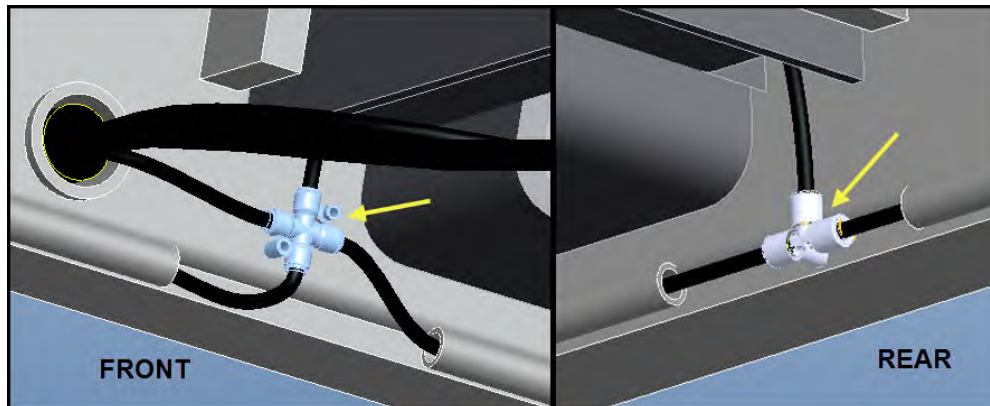

Figure 21. Air Connections

4. Connect the 3/8" polytube from the hose guard to the 3/8" fitting at the front of the left deck assembly (jacking beam air bracket). Before this can be done, remove the plug and replace with 1/4" NPT - 3/8" polytube straight adapter located in polybag "C" of hardware kit. **See Figure 22.**
5. Connect the opposite end of the 3/8" polytube to the Air Valve and Filter assembly on the front left tower. **See Figure 23.**

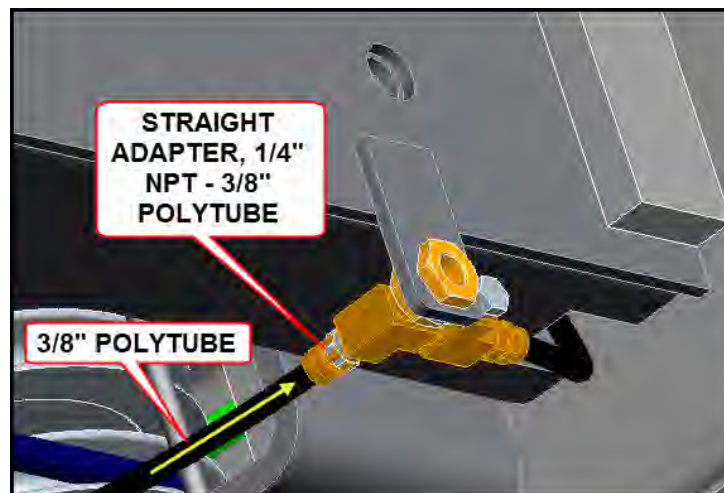

Figure 22. JB Air Connections

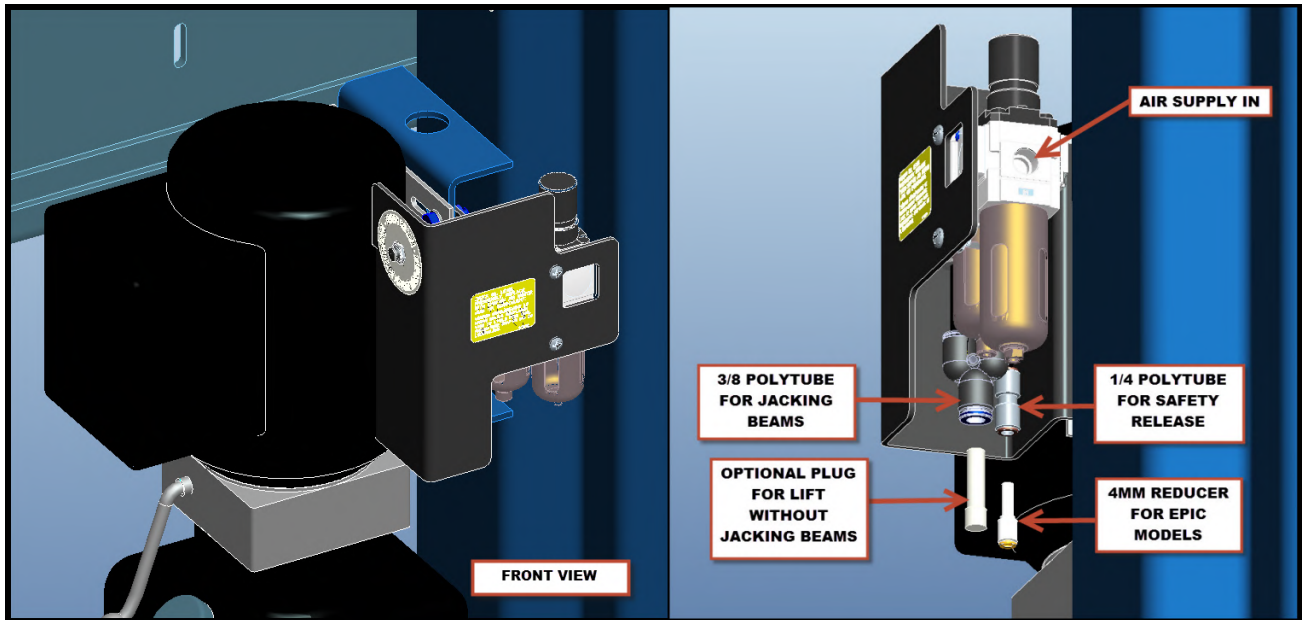

Figure 23. Air Connections

NOTE: For those units equipped with jacking beams, this is the appropriate time to install them. Consult the jacking beam instruction manual found in each jacking beam box.

6. Hook up an air supply to the inlet of the FRL. (Note: customer to supply this fitting)

7.9 ELECTRICAL CONNECTIONS

CAUTION: ALL ELECTRICAL CONNECTIONS SHOULD BE MADE BY A LICENCED ELECTRICIAN.

Refer to **Figure 24**, Electrical Diagram for electrical connections.
 Electrical Breaker Size Recommendation: 20Amps

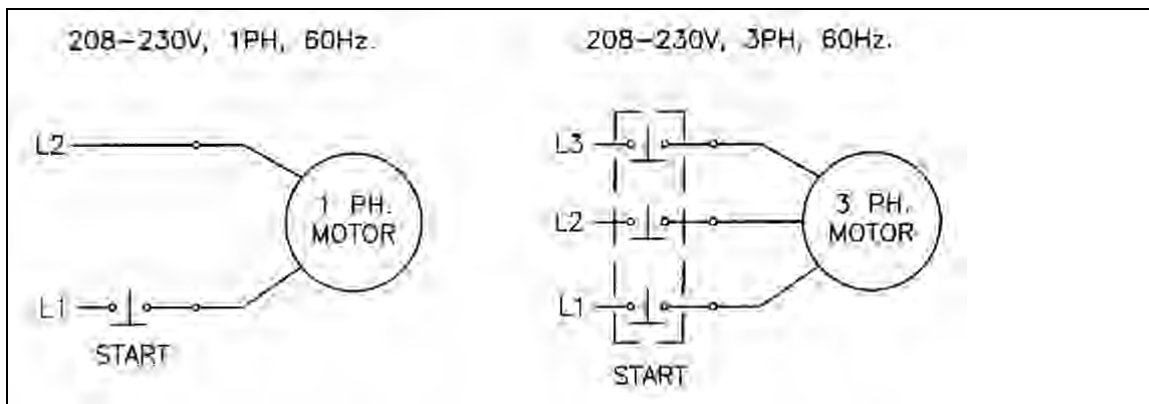

Figure 24. Electrical diagram for 230V/1 ph

7.10 FILTER/REGULATOR/LUBRICATOR COMMISSIONING

PROCEDURE FOR PREPARING FRL FOR USE WITH LIFT

1. Disconnect shop air from FRL inlet. Adding Oil to the lubricator cannot take place under a pressurized condition.



2. Using a slotted screwdriver or an Allen key, remove the filler cap from the top of the FRL.



3. Fill FRL using Snap-On AirOil #IM6 or equivalent. Oil to be filled to the MAX line marked on reservoir. If unit does not have MAX line mark, reservoir should be 80% full.

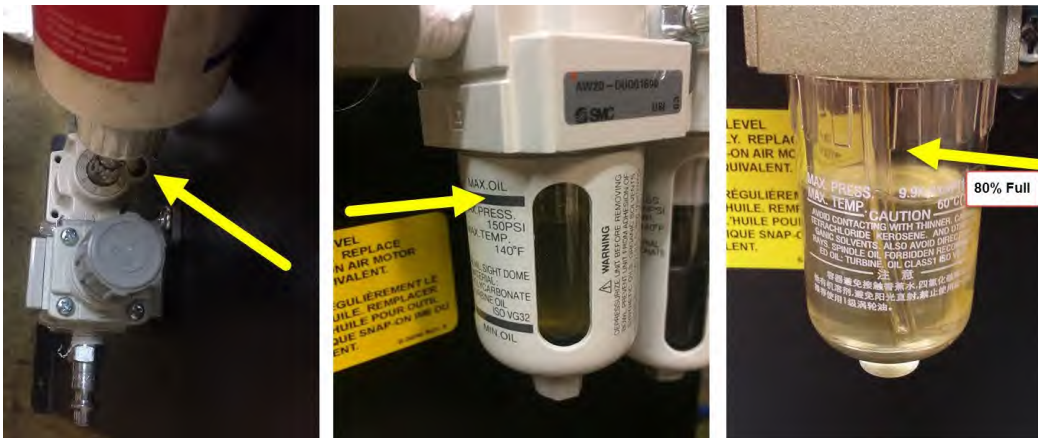

4. Replace filler cap to top of FRL.

5. With the output end of the FRL disconnected (remove the quick disconnect fitting), reconnect the air line to the FRL unit. Air will flow freely through the FRL.
6. Perform Drip Check / Adjustment: Drips to be set to 2-3 per minute.

SMC Brand - DIAL VERSION

- i. Turn the dial on the top end of the oil reservoir to the 2 position.
- ii. Count the number of drips for 1 minute.
- iii. Adjust between settings up or down to reach the desired drip rate.



JELPC Brand - SCREW VERSION

- i. Using a flat head screwdriver, turn the screw clockwise until it is closed.
- ii. Open the screw by turning counterclockwise a 1/4 turn.
- iii. Adjust by turning screw slowly in either direction to reach the desired drip rate.



7. PRESSURE ADJUSTMENT:

Pull up on the regulator knob and adjust the pressure to 100 psi. Pressure should be set between 90 - 120 psi.

8. Reconnect all airlines and check system for air leaks.
9. Check the operation of the air cylinder locks by pressing the pushbutton on the Air Valve and Filter Assembly on the front left post. This should cause the mechanical safety locks to disengage from the safety racks.
10. The pneumatics are now completely installed.
Press the "UP" button on the power pack and continue until the lift is fully supported by the cables.

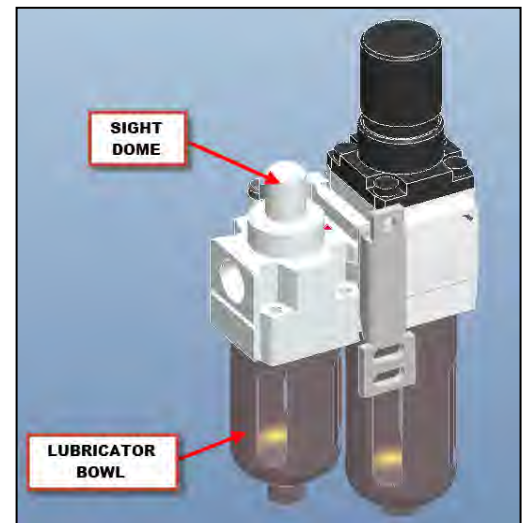

Figure 25: FRL

NOTE: MAKE CERTAIN THAT THE MECHANICAL SAFETY LOCKS AND CABLE ROLLERS ARE WORKING PROPERLY.

7.11 DECK LEVELING PROCEDURE

7.11.1 Leveling Lift to Floor

Note: Read the Operation Label on the powerpack for instructions.

1. Now that all the hydraulic and pneumatic connections are completed, push the up button on the powerpack to raise the lift off the jack stands.
2. Remove the jack stands and lower the lift completely to the floor.
3. Determine the highest corner of the lift and adjust remaining towers to level the lift, front-to-back and side-to-side (See positions 1, 2, 3 and 4 in **Figure 26**). Use shims under tower base plate, as needed. Individual towers should also be leveled in both front-back and side-side directions.

7.11.2 Deck Leveling Procedure

1. Raise the lift so that it is fully supported by the cables and is not resting on the safety ladders.
2. Using a self leveling laser (or 4' level), check the level of the decks front to rear and side to side as shown in **Figure 26**.
3. Lower the lift onto the nearest safety.

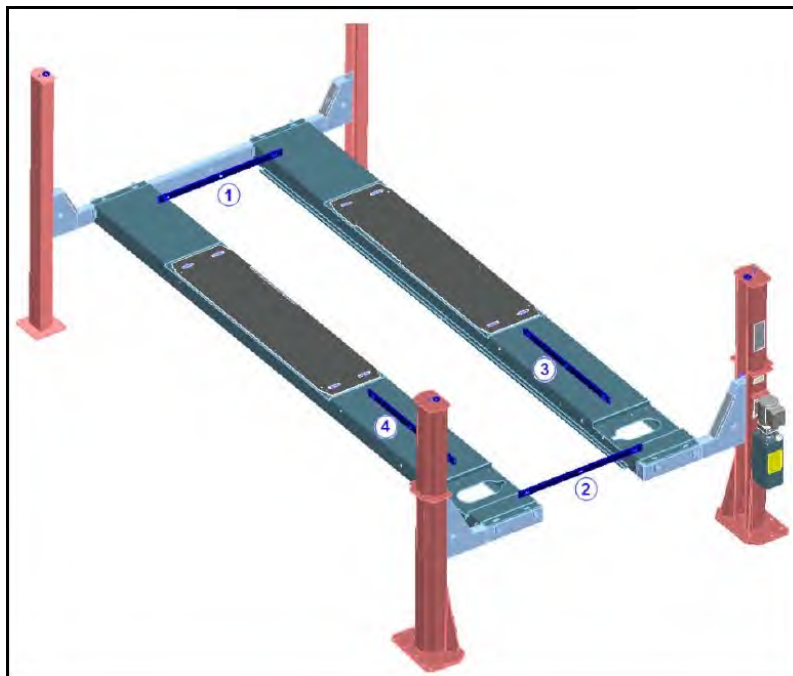

Figure 26. Deck leveling (Lift may not be as shown).

4. Adjust the cable lengths by tightening or loosening the two (2) 7/8"-14UNF hex nuts attached to each cable at the tower top plate to raise or lower each corner.

7.12 LEVELING ON SAFETY LADDERS

1. Repeat the preceding steps until the lift is completely level when supported by the cables.
2. Raise the lift so that the deck is supported by the cables and is not resting on the safety ladders.
3. Loosen the 3/8"-16 UNC × 1" LG. hex bolts at the bottom and top of each safety ladder (on the back side of the tower) and pull the safety ladders up until they come into full contact with each safety shoe on the crossmember assemblies. See **Figure 27**.
4. When flush with the safety shoe, tighten the two (2) 5/8"-11 UNC hex nuts at the top of each safety ladder and the 3/8"-16 UNC × 1" LG hex bolts at the bottom and top of each safety ladder (on the back side of the tower).

Figure 27. Ladder Leveling

5. Lower the lift onto the mechanical safety locks and verify level as shown in **Figure 26**. Make adjustments to safety ladder as necessary.
6. Raise the lift and check that the ladders engage evenly.
7. Raise the lift to its full height and check for full operating height of 72". This measurement is taken from the top of the decks to the bottom of the tower baseplate.

NOTE: If shims have been used under the tower, this dimension could be larger. If the floor is not even, this dimension may vary.

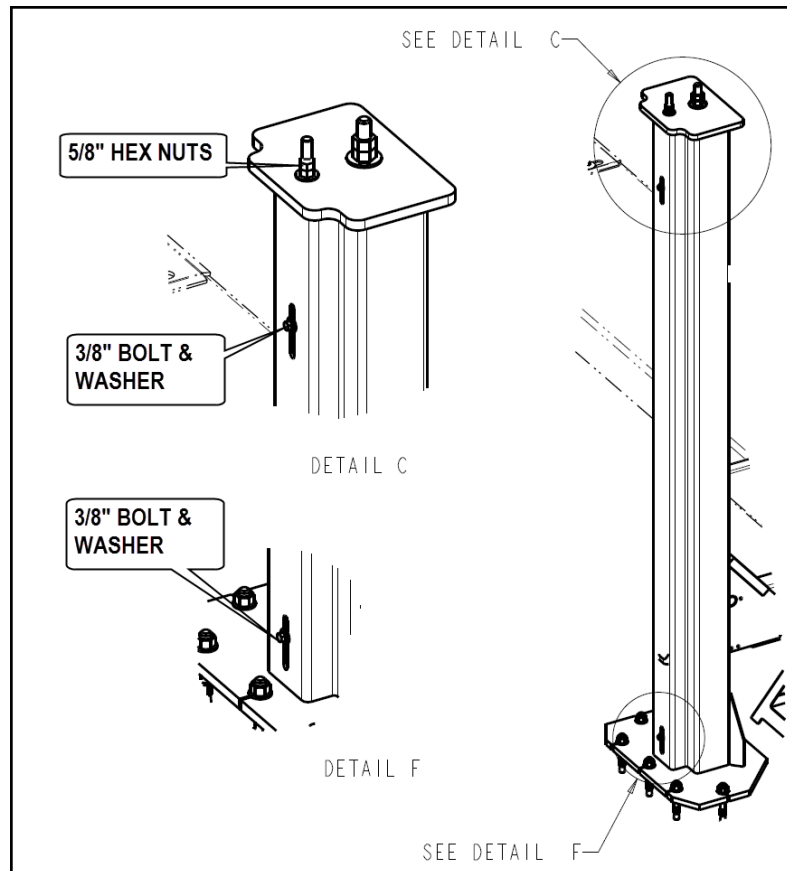

8. Cycle the lift several times to check proper operation of the cables, safety lock, air locks, etc.

STOP IMMEDIATELY IF THE LIFT IS NOT OPERATING PROPERLY.

9. Make any necessary adjustments and check again for proper operation.

7.13 ANCHOR INSTALLATION

Check all layout dimensions in the General Specifications in Figure 2 before continuing with anchor installation.

1. Refer to **Figure 28** while reading through these instructions.

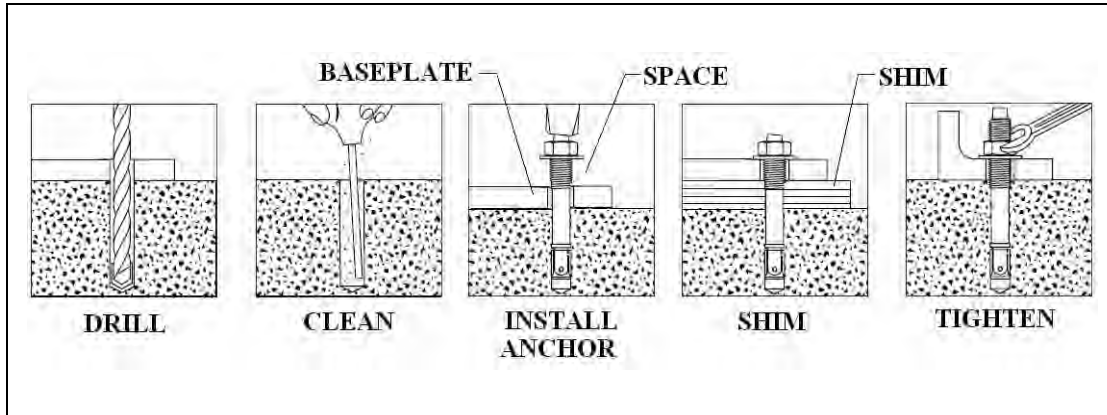

Figure 28. Anchor installation

2. Ensure that the lift is fully supported by the cables and is at a level just above ground. Work stands should be removed at this point.
3. Prior to installing anchors, assemble the nut and washer onto anchors. A minimum of six threads must be visible below the surface of the nut.
4. Using a 3/4" concrete drill bit and rotary hammer drill, drill through the concrete floor in the anchor holes positioned on the base of each post. (In case longer anchors are required, supplied anchors can be hammered through concrete).
5. Using a hammer, drive each anchor into floor leaving space for shimming.
6. Use a 4' level, to level the posts. See **Figure 30**.
7. Shim as required and hammer anchors till they make contact with Baseplate. Do not tighten anchors.
8. Check the distance from the top of the anchor to the floor. If this dimension exceeds 2 1/4" due to floor slope, **DO NOT** use the supplied anchors. Longer anchor must be used. See **Figure 29**.

⚠ WARNING Failure to ensure proper embedment of concrete anchors could lead to floor damage or possible failure of concrete floor resulting in injury or death.

9. Tighten all anchor bolts to a torque of 110 ft. lbs. Recheck and adjust the level of post(s) and cable(s) if necessary.

NOTE: If anchors do not tighten to required torque, OR project more than 2-1/4" above the concrete surface due to floor slope, contact a foundation engineer to determine the best course of action.

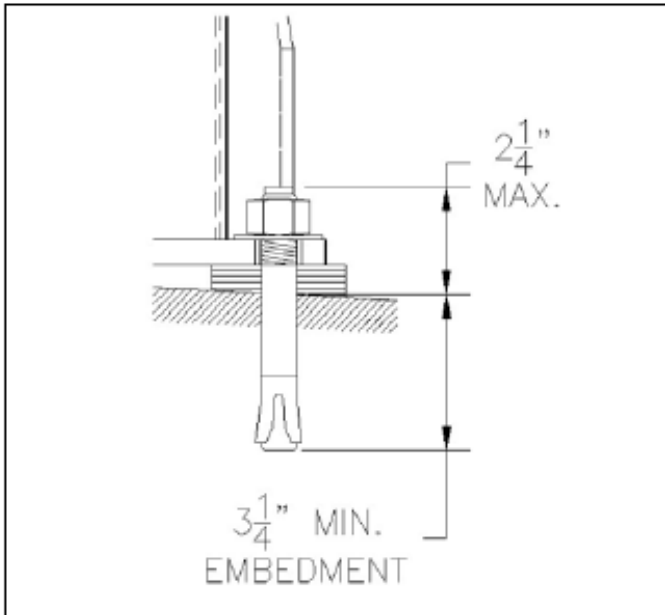

Figure 29: Embedment

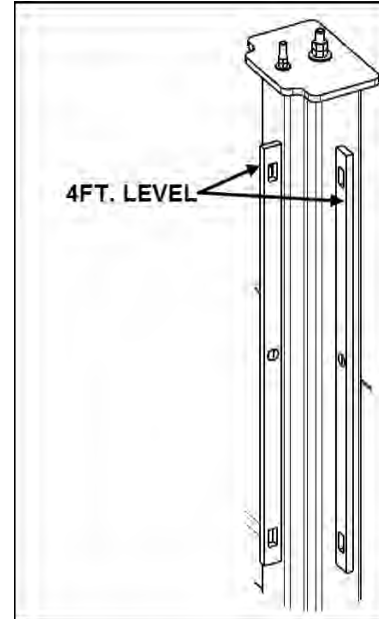

Figure 30: Leveling

NOTE: The 3/4" x 5 1/2" lg. wedge anchor bolts supplied must have a minimum embedment of 3 1/4" into concrete floor (see **Figure 29**).

NOTE: In cases where the floor is extremely out of slope, the mechanical safeties may not engage on the same lock.

⚠ WARNING DO NOT use more than 1/2" (13mm) of shims. Anchor bolt supplied allow for a maximum of 1/2" (13mm) of shim. If more than 1/2" (13mm) of shims are required, DO NOT proceed with installation and contact Snap-On Equipment Technical Support for further details.

7.14 ACCESSORY INSTALLATION

1. Install the front wheel stops using the 1/2"-13 UNC × 1"LG hex bolts, 1/2" lock washers and flat washers found in polybag "F" (Wheelstops/Ramps).

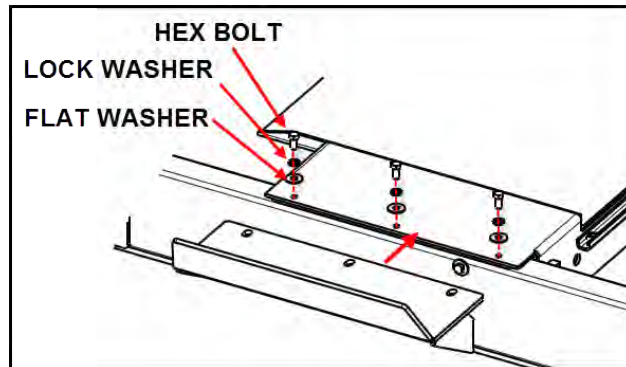

Figure 31: Front Wheelstops

2. Install the (4) sheave covers over the sheaves in the crossmember assembly. These are found in the accessory box.

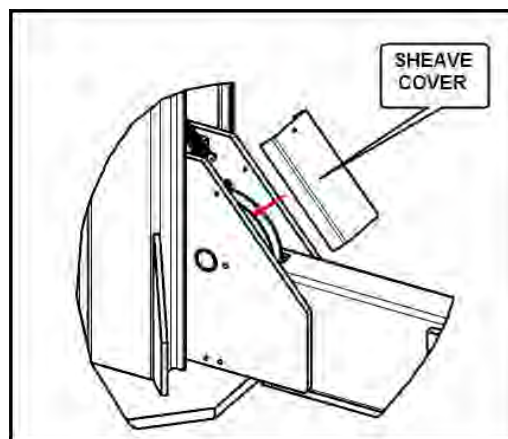
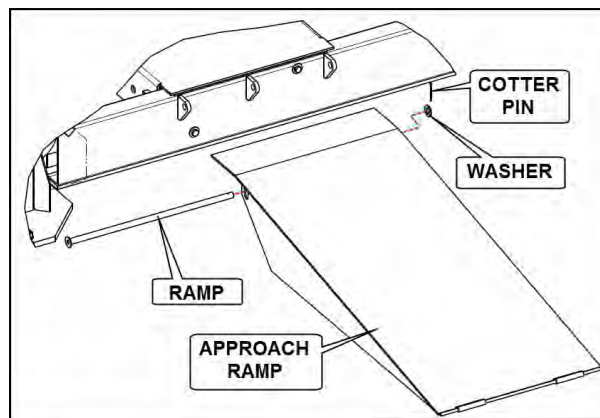

Figure 32: Sheave Cover

3. Install the approach ramps using the ramp pins, 1/8" x 2"LG cotter pins, 1/2" washers, and approach ramps provided. The ramps and ramp pins are located in the accessory box, the cotter pins and washers are found in polybag "E" (Misc.). Ensure the proper operation of the ramps.



**Figure 33:
Approach Ramp
Install**

4. Ensure the proper operation of the approach ramps.
5. Clean the outside sides of the runways with rubbing alcohol, acetone, or another degreaser.
6. Notice there are two Pinch Warning decals on the outside side of each runway, one towards the rear and one towards the front. Place the Large Hoffman Decals 2 inches from the rear Pinch Warning Decal on each side of the runway being careful to center the decal vertically. Note: it may help to use masking tape to template the location.



7. Cycle the lift several times to check proper operation of the cables, safety locks, air locks, etc. with and without load.

STOP IMMEDIATELY IF THE LIFT IS NOT OPERATING PROPERLY!

8. Make any necessary adjustments and check again for proper operation.

NOTE: IF THE LIFT IS EQUIPPED WITH JACKING BEAMS, THIS IS THE APPROPRIATE TIME TO INSTALL THEM. CONSULT THE JACKING BEAM INSTRUCTION MANUALS FOUND IN EACH JACKING BEAM BOX.



Before attempting to operate the lift, please ensure that slider guide surfaces inside the front towers are greased adequately.

7.15 FINAL CHECK OF ASSEMBLED LIFT

• Final dimension check after anchoring	
• Check for air and hydraulic leaks	
• Ensure cables are properly routed and free from obstructions	
• Ensure all safety lock mechanism are working correctly	
• Re-check level of post and decks	
• Makes sure ramps are secured correctly with cotter pins and washers	
• Check all fasteners, tighten if necessary	
• Check direction of flow control (arrow pointed toward power unit).	
• If jack beams are supplied, ensure keeper bracket are installed	
• Check jam nuts on cables and safety ladders are tightened	
• Ensure cable flange clamp at cylinder is installed correctly and tighten	
• Ensure cylinder shaft Jam Nuts are installed as per instructions	
• Ensure wheelstops are installed	
• Ensure wheel chocks are provided	
• Operate lift to full stroke then lower to ground while checking for proper functionality	

<ul style="list-style-type: none"> • Ensure Customer Care Kit is complete and given to operator 	
<ul style="list-style-type: none"> • Operation Manual 	
<ul style="list-style-type: none"> • ANSI / ALI Lift It Right Manual 	
<ul style="list-style-type: none"> • ANSI / ALI Safety Tip Card 	
<ul style="list-style-type: none"> • ANSI / ALI ALIS Safety Requirements for Installation and Service of Automotive Lifts 	
<ul style="list-style-type: none"> • ANSI / ALI Quick Reference Guide 	
<ul style="list-style-type: none"> • Train end user on operation of the lift 	
<ul style="list-style-type: none"> • Check level of hydraulic oil when the lift is fully lowered 	
<ul style="list-style-type: none"> • Check the movement of the wire ropes through the entire travel of the lift. Inspect for any binding or incorrect installation. Pay close attention to cable retainers at the crossmember sheaves. 	

8.0 OPERATING INSTRUCTIONS

⚠ WARNING To avoid personal injury and/or property damage, only trained personnel must operate the lift.

After reviewing these instructions, get familiar with lift controls, by running the lift through a few cycles before loading vehicle on lift.

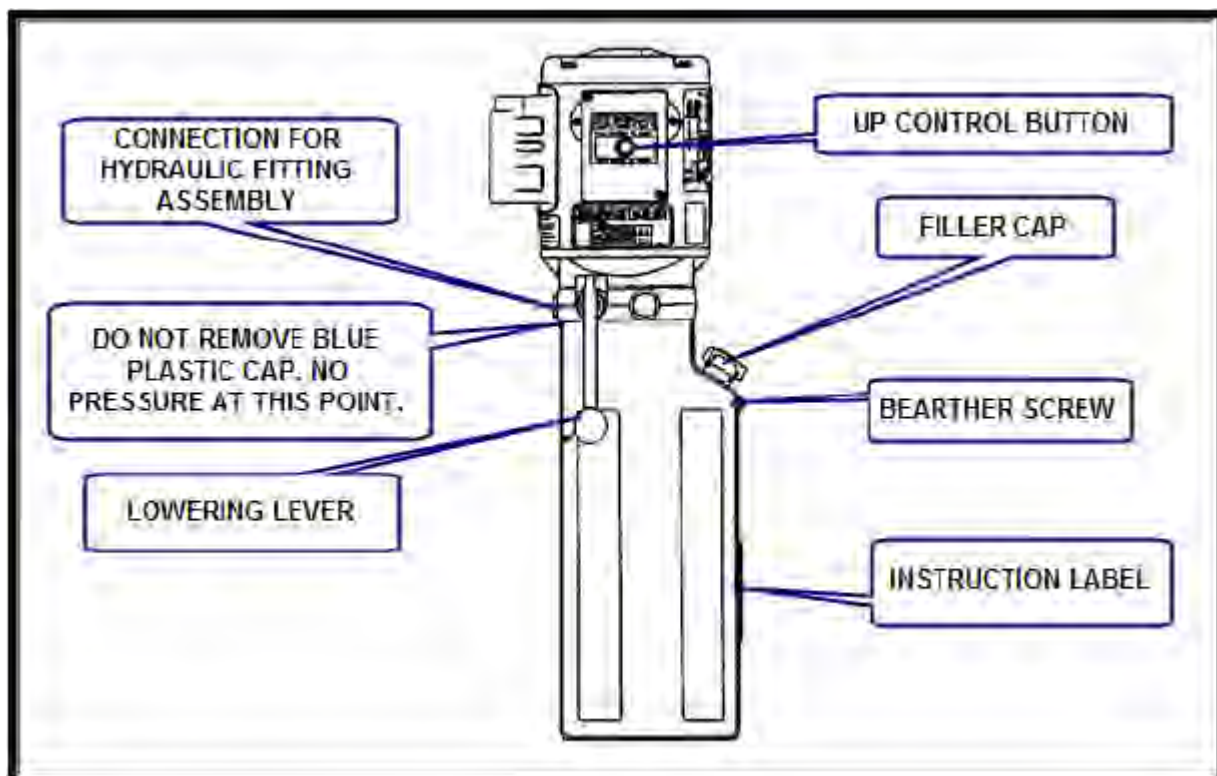

Read and follow **SAFETY** and **WARNING** labels on the lift.

LIFT OPERATION

- **Loading:** Ensure the lift is fully lowered and all personnel are clear of the service bay while driving the vehicle onto the lift. If the lift is equipped with rolling jacks, jacks must be fully lowered and the rear jack pushed toward center of lift, to provide under-car clearance.
- Stop vehicle well before it contacts the front wheel stops. At all times, be sure the rear wheels are forward of the approach ramps/chocks and the approach ramps/chocks will clear the tires when the lift is raised. Driver must exit the vehicle before rising.
- Place triangular wheel chocks on front and rear of one of the rear tires.
- **To raise the lift:** Push the “**RAISE**” button on the power unit. Release button at desired height, ensure that all corners have passed a mechanical lock position.
- After raising the lift to the desired height, press and hold the lowering lever on the hydraulic power unit, until lift stops on safety latches. Cross-members should be stopped on safety latches in all 4 towers before any work can start on the raised vehicle. If any of the safety latches is not engaged, try to raise or lower the lift to the next higher or lower safety position, and observe again if all 4 safety latches have engaged. If the problem persists, lower and unload the vehicle, solve the lift safety problem, and only then resume vehicle service.
- **Before lowering lift:** be sure no one is in the lift area and that all tools, tool trays, etc. have been removed from under the lift and vehicle. If the lift is equipped with rolling jacks, jacks must be fully lowered and the rear jack pushed toward center of lift, to provide under-car clearance.



The runways, approach ramps, and cross-members are designed to rest on the floor when fully lowered. Observe pinch point warning decals.

- **To lower lift:** if lift has been resting on the safety latches, the lift has to be raised high enough for all 4 safety latches to clear the openings in the latch plate (safety ladder).
- Actuate the latch release valve on the power unit column to disengage all four locking latches. Hold actuator until lift is fully lowered.

NOTE: If actuator on air valve is released, the latches will automatically reset to the engaged position.

- Push the lowering handle on the power unit to lower the lift.
- Observe lift and vehicle to be sure lift is level while being lowered. If not, STOP the lift and try to resume lowering as explained above.
- Fully lower lift, remove the triangular wheel chocks and check to be sure area is clear before removing vehicle from lift.

- If lift is not operating properly, do not use until adjustment or repairs have been made by qualified lift service personnel.
- For Rolling Jack operating instructions, see Rolling Jack Installation, Operation and maintenance Instructions in the rolling jack shipping box.

▲ WARNING

Do not operate lift with pulley covers removed from cross-member ends. Keep hands clear of the cross-member ends when lift is being raised or lowered.

▲ WARNING

Do not raise or lower the lift while the jack beams are loaded.

8.1 OPERATION TEST WITH VEHICLE

1. Lower lift to ground.
2. Drive vehicle on to lift, install wheel chocks.
3. Raise lift to and lower onto 3-4 lock positions during full rise to ensure all locks are working correctly.
4. Double check level of runways, front to rear and side to side while on locks.
5. Re-adjust cables if necessary while vehicle is on.
6. Check lowering speed and smooth decent rate.
7. Lower lift to ground, remove wheel chocks and drive vehicle off lift.

If any problems occur during the final checkout or operation of the lift please contact customer service at 1-800-268-7959

9.0 SAFETY AND OPERATING INSTRUCTIONS

1. **Inspect** the lift daily. Do not operate if malfunctions occur or damaged parts have been found.
2. **Never** attempt to **overload** the lift. The manufacturer's rated capacity is shown on the serial number tag on the power post.
3. **DO NOT OVERRIDE** the safeties. The mechanical safeties are designed to engage automatically on the way up. Press the up button on the power pack to go up. When the desired height is reached, release the power pack up button and lower the lift onto the safety. To lower the lift, raise off of the safety locks, then press the air release valve button and the lowering release lever at the same time.
4. **Only trained** and authorized personnel should operate the lift. Do not allow customers or bystanders to operate the lift or be in the lift area.
5. **Caution.** Never work under the lift unless the mechanical safety locks are engaged.

6. **Before driving** vehicle on, make sure lift is in the fully down position.
7. **Before removing** the vehicle from the lift, make sure the lift is in the fully down position and ensure that all tools have been removed from the deck surfaces.
8. **Always keep** the lift area free from debris. Grease and oil spills should always be cleaned up immediately. **Never leave** any tools or parts laying on the decks.
9. **Never operate** lift with passengers in vehicle.
10. **Always** raise the lift off safety locks before lowering.

NOTE: DO NOT ATTEMPT TO OPERATE THIS LIFT IF ANY PART IS NOT WORKING PROPERLY OR YOU HAVE NOT READ THE COMPLETE OPERATING INSTRUCTION MANUAL.

NOTE: DO NOT RAISE OR LOWER THE LIFT WITH THE VEHICLE ON THE JACKING BEAM.

11. Installation shall be performed in accordance with ANSO/ALI ALIS, Safety Requirements for Installation and Service of Automotive Lifts
12. For additional safety instructions regarding lifting, lift types, warning labels, preparing to lift, vehicle spotting, vehicle lifting, maintaining load stability, emergency procedures, vehicle lowering, lift limitations, lift maintenance, good shop practices, installation, operator training and owner/employer responsibilities, please refer to “Lifting It Right” (ALI/SM) and “Safety Tips” (ALI/ST).
13. For additional instruction on general requirements for lift operation, please refer to “Automotive Lift-Safety Requirements For Operation, Inspection and Maintenance” (ANSI/ALI ALOIM).

10.0 RECOMMENDED INSPECTION AND MAINTENANCE

10.1 LUBRICATION SPECIFICATIONS

Where hydraulic oil is required > ISO 32 10W - non detergent hydraulic oil

Where grease is required > multi-purpose lithium grease

Where multipurpose lube is required > multi-purpose SAE 30 lubricating oil

Where pneumatic oil is required > Snap-On air motor oil IM1PT

Where cable lube is required > NYROSTEN SEIOLOL wire rope lubricant or equivalent
(Part # for ordering: **EAK0299T39A**)

 **WARNING** If you are not completely familiar with automotive lift maintenance procedures, STOP. Contact Snap-on Equipment Technical Support for instructions. To avoid personal injury, permit only qualified lift service personnel to perform maintenance on this equipment.

Always raise lift when cleaning floor area with solvents and/or cleaning compounds.

Always replace cable break safety springs when replacing cables.

Please refer to the following table for specific inspection and maintenance frequency.

COMPONENT	INSPECTION FREQUENCY						
	DAILY	WEEKLY	MONTHLY	QUARTERLY	SEMI-ANNUALY	ANNUALY	
Entire Lift and surrounding area	8.15					As shown before, and ALI Standard	
Entire Lift Operation	8.15						
Fasteners		8.3					
Wire Ropes		8.2.3	8.2.4	8.2.5			
Sheaves		8.4.1		8.4.2			
Sheave Pins		8.4.3		8.4.2			
Safety Dogs	8.5		8.3				
Slack Cable Devices	8.6						
Latch Plates (Ladders)			8.6				
Air Filter, Regulator, Lubricator	8.7						
Approach Ramps, Chocks, Wheel Stops	8.12						
Anchor Bolts			8.11.2				
Turn Tables and Rear Slip Plates	8.13.1		8.13.2	8.13.3	8.13.5		
Bearing Cage / Rear Slip Plates	8.13.1		8.13.2	8.13.4	8.13.5		
Edges of Cable Flange Slots	8.2.6						
Runways			8.10.1				
Columns			8.11.1				
Air cylinders, Lines, Fittings			8.7				
Hydraulic Power Pack, Hose, Fittings			8.8				8.8
Hydraulic Cylinder				8.9			
Jack Beam Rails, Oil Drain Pan				8.10.2			
Anti-skid Surfaces				8.13.5			
Rolling Air Jacks			8.14				

10.3 WIRE ROPES

⚠ WARNING

Wire ropes are critical to safe and reliable performance of your lift. Cables are expendable items and should be replaced as a set.

10.3.1 Wire Rope Conditions Guide

Typical good cable

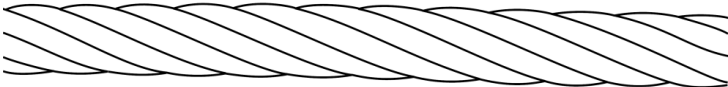

Cable with necking



Broken wires

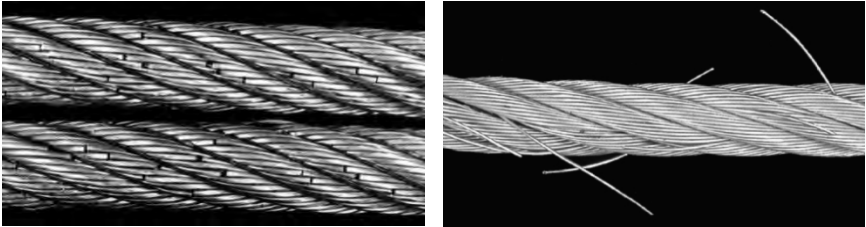

Excessive wear of wires

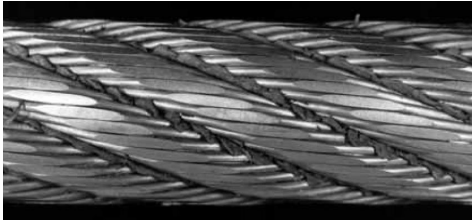

Rust on sheave stack and ropes



Corrugated sheave groove

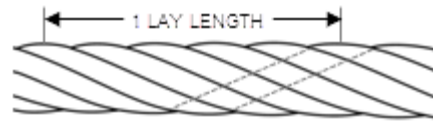

Figure 15

10.3.2 Wire Rope Replacement Criteria



WARNING If any cable is found to be in need of replacement, the entire cable set, pulleys and safety rollers must be replaced immediately. See 8.2.1, cable conditions guide.



In the following table, "lay" means the distance measured along a line parallel to the axis of the rope in which the strand makes one complete turn about the axis of the rope, or the wires make a complete turn about the axis of the strand.

The wire rope must be removed from service if one or more of the following criteria are met:	
1.	More than six randomly distributed broken wires in one rope lay or 6×d length.
2.	More than three broken wires in one strand in one rope lay or 6×d length.
3.	Three or more broken wires at rope terminations.
4.	One outer wire broken at the point of contact with the core of the rope which has worked its way out of the rope structure and protrudes or loops out from the rope structure
5.	Heavy rusting, corrosion, or pitting. A light surface corrosion on outer wires is normal.
6.	Wear or scraping of one-third of the original diameter of outside individual wires
7.	Excessive stretch. It is normal for new cable to require adjustment during "break-in", after which small periodic adjustments may be required. However, if a cable that has been in service for 6 months suddenly require frequent adjustments or has used all the cable adjustment available, all cables must be replaced immediately.
8.	Deformed strands, kinking, crushing, birdcaging, or any other damage in distortion of wire rope structure
9.	Variations in diameter (necking) or any change from normal appearance
10.	Reductions from nominal diameter of more than 1/32" (for cables 3/8" to 1/2" dia. inclusive)
11.	End attachments cracked, deformed or worn

10.3.3 Wire Rope Inspection

Inspect wire rope cables for wear or damage. Wipe cables with a rag to detect hard to see small broken or frayed cable strands. See chapter 8.2, Fig.15 and ANSI/ALI ALOIM standard.

10.3.4 Wire Rope Lubrication

Lubricate wire ropes with lift in both lowered and raised position, by spraying them with wire rope lubricant (i.e. NYROSTEN SEIOL).

10.3.5 Wire Rope Adjustment

Adjust cables if lifting is uneven or lift is not level (See chapter 6.10.3). Never make adjustments with weight on lift. If running out of adjustment threads, cables need to be replaced. Do not add washers or other spacers to re-use previously used adjustment threads.

Wire rope tension adjustment should be performed when installing the lift and every three months.

10.3.6 Inspect Cable Flange

Make sure the edges of the counter-boreds in the cable flange are not damaged or worn, indicating that cable sleeves may not be properly seated at all times.

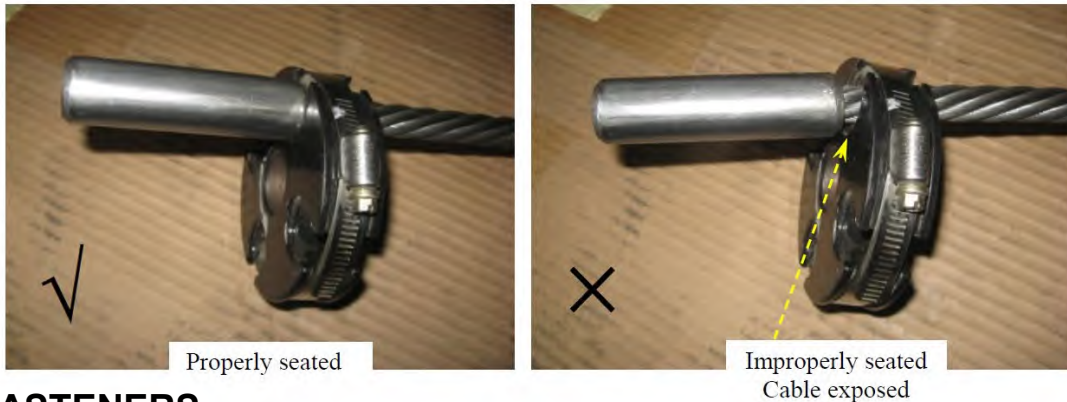

10.4 FASTENERS

Check all the attaching bolts and nuts for tightness.

Note: Air cylinder bolts and nuts should allow movement of the cylinder.

10.5 SHEAVES & PINS

Sheaves and pins are expendable items. Sheaves and pins should be replaced when worn. Use of sheaves and pins with excessive wear will lead to reduced service life of the cables.



WARNING

Bushings inside sheaves work best in “dry” condition. Applying oil will diminish their performance and greases will degrade performance even further. **DO NOT GREASE SHEAVE BUSHINGS OR SHAFTS.**

10.5.1 Visual Inspection of Sheaves

Check sheaves and replace if cracks or other damage are found.

Visually inspect alignment of sheaves. Misalignment of sheaves indicates excessive wear. Remove, inspect, and, if needed replace sheave and pin.

10.5.2 Measure Sheave Wear

- Inspect sheaves in cross-members with lift in lowered position and resting on safety latches
- Place safety stands under front and rear cross-members. Stop lift on mechanical safety locks. One person should hold the lowering handle on power unit down while another person pulls on cables in each column to create slack in cables.

- Check for ease of rotation. If sheaves do not turn freely, the sheave and sheave pin should be removed, inspected, fixed or replaced.
- Fully raise the lift, to inspect sheaves in runways. Hold lowering handle down to lower lift onto safety latches
- Pull on cables in runway to create slack in cables.
- Check all sheaves for excessive wobble, or movement. Grasp rim of sheave and attempt to wobble (tilt) side to side. If sheaves wobble (tilt) more than 3/16" (1.6 mm) side to side, or move in and out more than 1/32 (0.8 mm), the sheave and sheave pin (shaft) should be replaced. Replace immediately if needed.

10.5.3 Sheave Pins

Sheave pins are held in place by a Hex Head Bolt, washer and lock washer.

- Check for loose sheave pins, loose or missing fasteners to hold sheave pins in place. Remediate situation immediately.

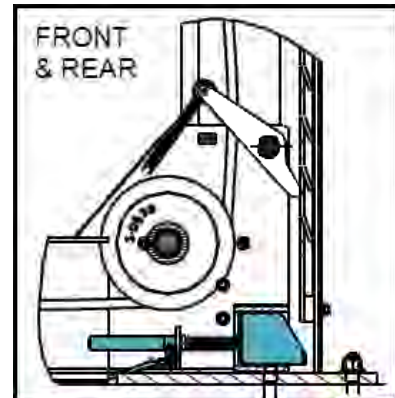

10.6 MECHANICAL SAFETY LATCH (DOG)

- Watch and listen to safety latch operation during lift operation, to ensure that latches move as required, have not lost spring preload, and line up with slots in latch plates (safety ladders) in columns.
- Watch for broken traction springs on safety latches.
- Check and adjust safety ladders if lift is not level on safety, or if safeties do not engage properly. Stop using the lift if any malfunction or damage is observed.

10.7 AUXILIARY SAFETY MECHANISM

With lift not loaded, all four cable break levers should produce deflection of the lift cables. Inspect slack cable device as follows:

- Check for missing or damaged parts.
- Watch for broken springs. Check if the spring is properly seated in the support tube and in the holder on the cable break safety lever.
- Watch cable tracking properly on cable break safety roller.
- Check if the safety roller and bolt are properly attached to the cable break safety lever.
- Verify that the cable break safety lever is centered within the cross-member, and that it lines up with the openings in the safety ladder.
- Verify using hand force or a light lever that the cable break safety lever pivots on the shaft. Lubricate with light lubricant if required.

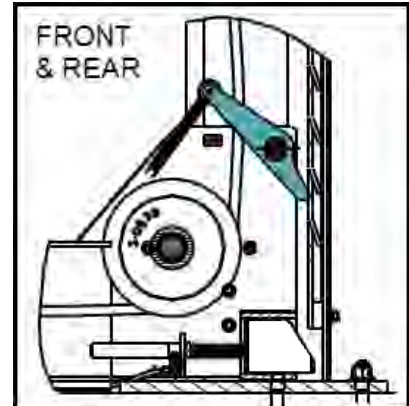

10.8 AIRCYLINDERS, AIR LINES, VALVES AND FITTINGS

10.8.1 General Checks

- Check filter/regulator/lubricator in supply line to lift. (customer supplied, typically at compressor). Drain water trap filter bowl and adjust oil feed according to manufacturer's instructions.
- Drain water bowl on lift supplied water separator. Press valve at the bottom of the bowl to clear.
- Check operation of air release valve for air leaks.
- Check air cylinders for visible damage.
- Check air lines for leaks, wear or kinks.

10.8.2 Air Lubricator Oil Level

NOTE: Failure to maintain oil level in lubricator will **void warranty** of all pneumatic components.

MAINTENANCE

- Refill oil reservoir using instructions above before the oil level reaches the MIN OIL line on the reservoir.
- Recheck drip rate after refilling.
- Check pressure is adjusted to 100 psi.
- The FRL unit is autodrain. However, you can drain the water trap filter bowl by pressing valve at the bottom of the bowl until all water has drained.



10.9 HYDRAULIC POWERPACK AND HOSE

- Check all air and hydraulic hoses, fittings and cylinders for leaks.
- Check level of oil in power pack reservoir when lift is in the lowered position. Add if required.
- Check fluid level of lift power unit and refill if needed. If refill was needed, inspect all fittings, hoses and seals. Tighten, repair or replace as required.
- Change hydraulic fluid every 2 years.

10.10 HYDRAULIC CYLINDER

- Inspect the hydraulic cylinder mounting to the runway. Inspect cylinder and hydraulic hose for leaks. Repair or replace as required.
- Check and tighten the hydraulic cylinder rod nuts holding the cable flange.

- Inspect bolts holding anti-rotation bar onto cable flange and tighten if required. (If applicable)
- Inspect sliders on anti-rotation bar for excessive wear or damage. Replace if required. (If applicable)



WARNING Failure to do so will lead to reduced service life, which could result in property damage and/or personal injury.

10.11 RUNWAYS

10.11.1 Check Runways

- Check level of runways on the floor, on the locks and on the cables: Refer to **Section 6.10**. Adjust as required.
- Check runways for damage or abnormal deformation. If such conditions exist, contact Snap-on Equipment Technical Support.

10.11.2 Inspect Jackbeam Tracks

- Inspect rolling jack / oil drain pan tracks for cleanliness, corrosion, excessive wear or damage.
- Clean dirty tracks.
- Worn or damaged tracks should be repaired immediately.

10.12 COLUMNS

10.12.1 Check Columns

- Check columns for corrosion, giving special attention to the area at the base of the column.
- Check severely corroded areas by pecking with an awl or welder's chipping hammer.
- If column is corroded through at any point, it must be replaced immediately.
- If not corroded through, remove old paint and rust scale, then coat with a high quality corrosion resistant paint. Clean and lubricate glide blocks.

10.12.2 Check Column Anchors

- Check column anchor bolts for tightness (if loose, re-torque to 110 ft-lb). If anchors do not tighten to required torque, or continue to loosen, contact Snap-on Equipment Technical Support.
- Verify proper embedment of anchors after tightening.

NOTE: The 3/4" × 5 1/2" lg. wedge anchor bolts supplied must have a minimum embedment of 3 1/4" into concrete floor.

NOTE: If anchors do not tighten to required torque, OR project more than 1 1/2" above the concrete surface due to floor slope, contact a foundation engineer to determine the best course of

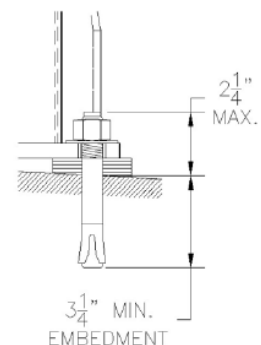

10.13 APPROACH RAMPS, CHOCKS, FRONT WHEEL STOPS

- Inspect for excessive wear or damage. Repair or replace if required.
- Inspect hinge pins. Replace if excessively worn. Lubricate if in good condition

10.14 FRONT AND REAR TURN/SLIP PLATES

10.14.1 Visual Inspection

- Check front turn tables and rear slip plates for unusual deflection, damage, fluid spills.
- Clean or further inspect if needed.

10.14.2 Clean Rear Slip Plates and Front Turn Tables

- Clean foreign debris from front turn tables and rear slip plates by blowing out with compressed air.
- Check and clean steer plates. Lubricate with oil or light grease.

10.14.3 Maintenance of Rear Steer Plates

- Inspect the non-skid coating on rear slip plates for wear. All areas found to be worn smooth should be resurfaced with an Anti-Slip abrasive floor tread tape or a heavy duty Anti-Slip Floor Coating.
- Remove rear slip plate covers. Clean runway surface and touch up any paint wear with a rust resistant paint. Allow paint to dry thoroughly. Inspect transfer balls for excessive wear, deformations or corrosion.
- Inspect plastic pads (pucks) for excessive wear or deformation. Replace if needed.

10.14.4 Maintenance of Rear Steer Plates - If Equipped with Plastic Bearing Cage

- Remove top Slip Plate covers by first removing the four (4) shoulder bolts on each cover.
- Remove polyethylene-bearing cages insuring that all the Delrin bearings remain in the cages. Additional Delrin bearings may be purchased if required.
- Clean runway surface and touch up any paint wear with a rust resistant paint. Allow paint to dry thoroughly.
- To obtain optimum performance, the position of the slip-plate bearing cage should be rotated every quarter to change the wear pattern.
 - With the first quarter maintenance, flip the bearing cage over to the opposite side.
 - With the second quarter maintenance, rotate the bearing cage end-to-end.
 - With the third quarter maintenance, flip bearing cage over to the opposite side.
 - Fourth quarter maintenance should see the bearing cage rotated back to the original position.

- Quarterly maintenance will optimize performance and contribute to longer slip plate life.

10.14.5 Anti-Skid Coating on Rear Steer Plates

- Inspect the non-skid coating on rear steer plates for wear. All areas found to be worn smooth should be resurfaced with an Anti-Slip abrasive floor tread tape or a heavy duty Anti-Slip Floor Coating.

10.15 ROLLING AIR JACKS

- Lubricate roller bearings and roller guide springs.
- Dismantle and clean lift arms.
- Clean and lubricate rollers/sliders and hinge points.
- Clean and lubricate safety mechanism.
- Change hydraulic oil every two years

10.16 ENTIRE LIFT

- Wire ropes, columns, runways and other lift parts should be kept free of corrosive agents, solvents, and road salts. If such agents are spilled or splashed on any lift component, immediately rinse thoroughly with water and wipe down with a clean rag. Lubricate again wire rope as shown at **8.2.4**.
- Check general operation of lift. Observe any structural noise, imbalance, binding, or other malfunctions.



Failure to keep the lift free of corrosive agents and solvents will lead to reduced component service life, cable failure, etc., which could result in property damage and/or personal injury.

11.0 LOCK OUT AND TAG OUT INSTRUCTIONS

IMPORTANT: This machine does not have integral devices that will isolate the electrical, pneumatic, stored and hydraulic energy source. Appropriate isolation or blocking devices must be used that have the provisions to be switched in the off position and locked in that position.

ALL MAINTANANCE AND SERVICE MUST BE PERFORMED BY A QUALIFIED PERSON.

ALL MAINTANANCE AND SERVICE MUST BE PERFORMED WITH THE LIFT UNLOADED.

IT IS THE SHOP OWNERS RESPONSIBILITY TO ENSURE ENERGY ISOLATING DEVICES ARE:

- Accessible

- Conveniently located to facilitate the application of lockout devices during service and maintenance
- Located outside any hazardous area.
- At a convenient manipulating height (i.e. not overhead, on ladders or under machinery)
- Adequately labeled or marked. Identification shall include machine ID, energy type and magnitude.
- Capable of being locked or otherwise secured in an effective isolating position.

Effective hazardous energy control procedures will protect employees during machine and equipment servicing and maintenance where the unexpected energization, start up or release of stored energy could occur and cause injury, as well as while working on or near exposed de-energized electrical conductors and parts of electrical equipment. Hazards being guard against include being caught in, being crushed by, being struck by, being thrown from, or contacting live electrical circuits/parts.

In preparation for lockout, an initial survey must be made to locate and identify all energy isolating devices to be certain which switch, valve, or other energy isolating devices apply to the machine / equipment to be locked out. More than one energy source (electrical, hydraulic, pneumatic, or others) may be involved.

- SHUT DOWN PROCEDURE:

- Notify all affected employees that a lockout or tagout system is going to be utilized and the reason for. The authorized employee shall know the type and magnitude of energy that the lift utilizes and shall understand the associated hazards.
- ELECTRICAL: Located at the main electrical cabinet, and turn off the breaker to the lift disconnecting the raise and lower functions.

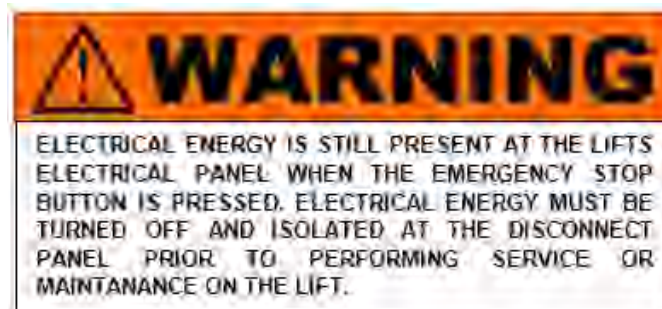

11.1 ISOLATION AND VERIFICATION PROCEDURE:

Table 1: ISOLATION AND VERIFICATION PROCEDURES:

ENERGY TYPE AND SOURCE	LOCKOUT LOCATION (TO BE COMPLETED BY END USER)	PROCEDURE FOR LOCING OUT AND OR RELEASING ENERGIES	VERIFY PROCEDURES
<p>STORED ENERGY</p> <p>AND</p> <p>HYDRAULIC PRESSURE 3000-5000 PSI</p>		<p>LOWER THE LIFT TO ITS LOWEST REST POSTION. IF THE LIFT MUST BE SERVICED OR MAINTAINED IN THE RAISED POSITION, ENSURE THAT THE LIFT IS PLACED ON THE MECHANICAL LOCKS AND SUPPORTED BY SUPPLEMENTARY JACK STANDS, BLOCKED AT THE SLIDERS AND A COME ALONG SECURED BETWEEN THE SCISSORS.</p>	<p>VERIFY THAT THE LIFT IS CONTACTING THE SUPPLEMENTARY JACK STANDS, THE BLOCKS ARE SECURLY PLACED AND THE COME ALONG IS SECURED BETWEEN THE SCISSORS.</p> <p>PRESS THE DOWN BUTTON ON THE CONSOLE AND VERIFY THAT THE LIFT DOES NOT LOWER. VERIFY HYDRAULIC PRESSURE HAS BEEN REMOVED BY SLOWLY OPENING THE MAIN HYDRAULIC FITTING AT THE POWER UNIT ONLY. IF FLUID IS PRESENT UNDER PRESSURE, IMMEDIATLY TIGHTEN AND REPEAT LOWER PROCESS. ENSURE THAT BOTH STRUCTURES ARE SECURELY PLACED ON THE STANDS AND BLOCKED.</p>
<p>ELECTRICAL 240VOLTS</p>		<p>AT THE LIFT, PRESS THE EMERGENCY STOP BUTTON COMPLETELY TO DE-ENERGIZE THE CONTROL BUTTONS.</p> <p>AT THE DISCONNECT PLANEL, PLACE THE DISCONNECT HANDLE IN OFF POSITION. ATTACH A MULTIPLE LOCKOUT DEVICE. LOCK AND TAG.</p> <p><u>DANGER: LINE SIDE OF DISCONNECT REMAINS ENERGIZED</u></p>	<p>ATEMPT TO RESTART THE SYSTEM, THE SYSTEM MUST NOT START. VISUALLY VERIFY OPEN DISCONNECTS AND LOCKING DEVICE INSTALLED.</p>

<p>PNEUMATIC UPTO 160PSI</p>		<p>SLOWLY CLOSE LOCKOUT VALVE TO RELEASE AIR PRESSURE GRADUALLY. ATTACH MULTIPLE LOCKOUT DEVICE, LOCK AND TAG.</p> <p><u>DANGER: LINE SIDE OF DISCONNECT REMAINS PRESSURIZED</u></p>	<p>VERIFY THE VALVE IS CLOSED AND LOCKOUT DEVICE IS PROPERLY ATTACHED. OPERATE THE PNEUMATIC SYSTEM TO ENSURE THE SYSTEM IS DE-ENERGIZED. IT MAY BE NECESSARY TO BLEED THE SYSTEM OF REMAINING COMPRESSED AIR, THIS CAN BE PERFORMED AT THE BASE OF THE WATER SEPARATOR BOWL.</p>
---	--	---	---

- RETURNING TO SERVICE:

- Check the lift and the immediate area around the lift to ensure that nonessential items,, tools and parts are removed and that the lift components are operationally intact.
- Check the work area to ensure that all employees have been safely positioned or removed from the work area.
- Notify all employees that the lockout/tagout is going to be removed and the lift is going to restarted.
- Remove the lockout/tagouts in the reverse order as the installation.
- Verify the proper operation of the equipment.
- Notify affected employees that the maintenance/service is completed and the machine is ready for operation.

11.2 EMERGENCY OPERATION

If the lift becomes inoperative in the raised position, it is best to wait until the electrical power is restored before lowering the vehicle. However, if it's critical to safety that the lift be lowered, the following steps should be taken.



WARNING: DO NOT LOOSEN OR REMOVE HYDRAULIC CONNECTIONS OR FITTINGS UNDER PRESSURE. SERIOUS INJURY OR DEATH COULD OCCUR.

NOTE: Safely performing this process requires 3 people. All personnel should stay clear of the path of the lift. All tools and other non-secured items should be removed from the surface of the ruways.

- 1) Survey the area surrounding the lift; remove any items and personnel from area before proceeding with this procedure.
- 2) Perform the appropriate lockout/tag out procedure on the electrical energy.
- 3) Add additional chocks to the vehicle to secure it from movement in the forward and rear direction.

- 4) Use a second person standing at a safe distance away from the lift to keep watch on the area, lift, vehicle and other personnel throughout the process. This person should signal the person performing the procedure to stop if necessary.
- 5) Use a caution tape or similar to barrier the area around the lift to avoid personnel from accidentally entering the area while this process is being performed.
- 6) Do not proceed with this procedure if you are unfamiliar with the lift or its function.

IF THE MECHANICAL LOCKS ARE NOT ENGAGED:

- 1) **If there is air pressure in the pneumatic system;** have another person press and hold the mechanical safety release button to disengage the mechanical locks. Confirm that all mechanical locks have been disengaged and will allow the lift to lower.
If there is no air pressure in the pneumatic system; use a portable compressor to provide a temporary air supply to the system.
- 2) Press and hold the safety release button.
- 3) Verbally indicate to all those involved that the lift will now be lowered.
- 4) Slowly push the lowering lever on the powerpack to lower the lift.
- 5) Keep a close eye on the movement of the lift and the position of the vehicle; release the lowering lever if any abnormal movement is detected.
- 6) Once the lift is fully lowered, disconnect the temporary air supply.
- 7) Once power is restored follow the lockout/tag out procedure to return the lift back into service.

IF THE MECHANICAL LOCKS ARE ENGAGED:

Various methods can be used to raise the lift in order to get sufficient clearance to disengage the mechanical locks. The safest method would employ temporary electrical power to the lift using a portable power generator. Any electrical connections should be done by a licensed electrician; lock out/tag out procedures should also be employed at this time.

This process should only be performed by a trained professional. Contact customer service or a local service professional for further assistance.

12.0 PARTS LIST

12.1 LIFT ASSEMBLY

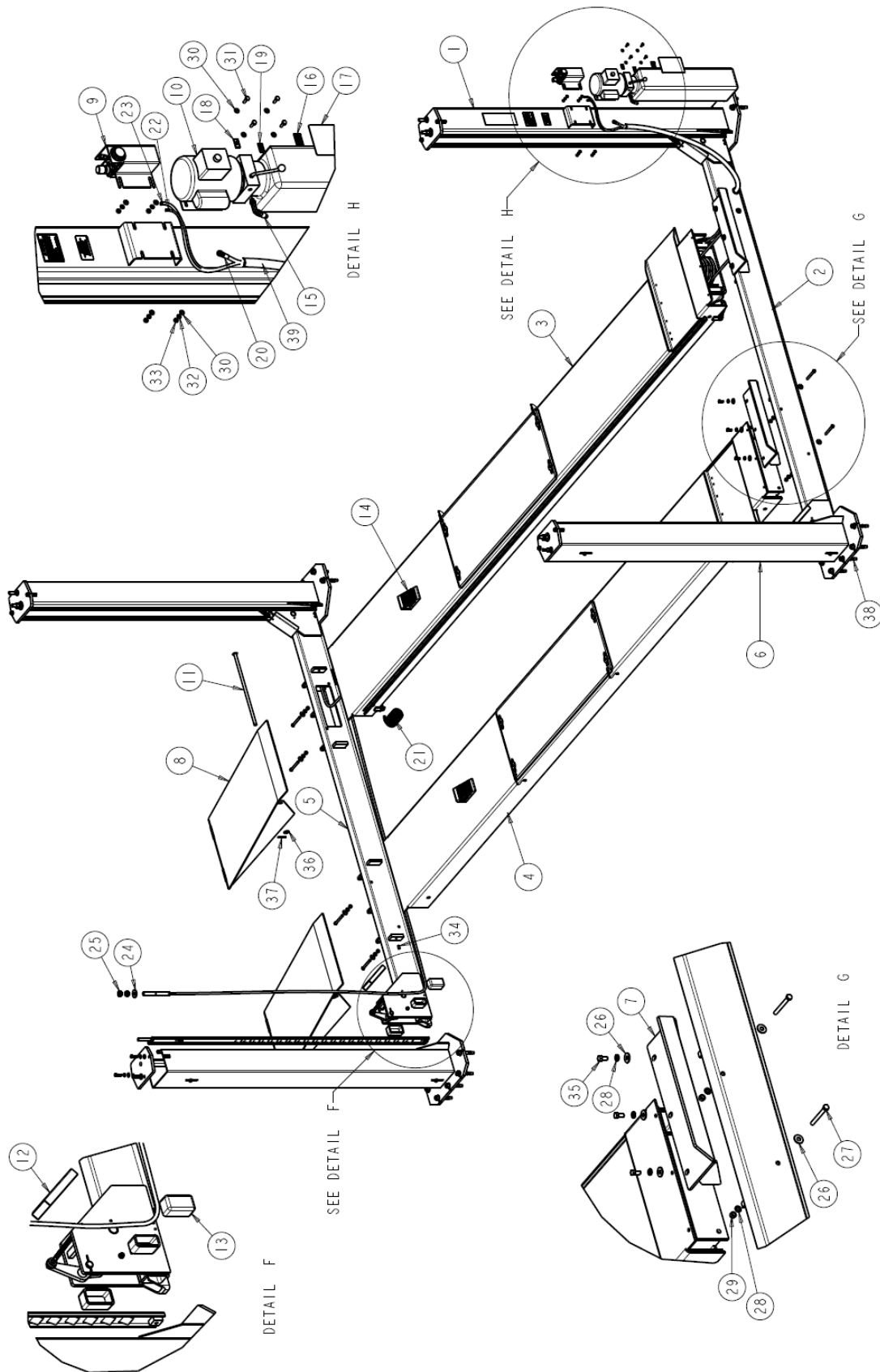

12.2 PARTS LIST – LIFT ASSEMBLY

REPLACE WORN, DAMAGED OR BROKEN PARTS WITH PARTS APPROVED BY THE ORIGINAL EQUIPMENT MANUFACTURER ONLY

Item#	Part #	Description	Qty.
1	4-1457	POWER TOWER (FL) ASSY	1
2	4-0657-3	FRONT CROSSMEMBER ASS'Y	1
3	4-0656-3	DECK ASSEMBLY, LS	1
4	4-0659-3	DECK ASSEMBLY, RS	1
5	4-0658-3	REAR CROSSMEMBER ASS'Y	1
6	4-1458	POWER SLAVE ASSY	3
7	2-0998	WHEELSTOP WELDMENT	2
8	3-0680	APPRACH RAMP WELDMENT	2
9	2-3005	FRL & SAFETY RELEASE ASS'Y	1
10	6-1695	Power Pack, 208-230 V, 1 PH	1
11	2-1381	PIN WELDMENT - RAMP	2
12	2-1379	PULLEY COVER	4
13	2-0772	SLIDER BLOCK	8
14	6-1661	WHEEL CHOCK	2
15	6-1691	FLOW CONTROL	1
16	6-3623	DECAL, SAFETY RELEASE	1
17	6-4045	FOUR POST OPERATING INSTRUCTIONS	1
18	6-3031	DECAL, "UP"	1
19	6-3032	DECAL, "UP"	1
20	6-1692	HYDRAULIC HOSE ASSEMBLY	1
21	6-0337	RECOIL HOSE	2
22	6-1396	1/4" POLYTUBE, 10FT LONG	1
23	6-1400	3/8" POLYTUBE, 10FT. LONG	1
24	6-0725	7/8 ID FLAT WASHER	4
25	6-0724	Hex Nut, 7/8"-14UNF	8
26	6-0063	FLAT WASHER, 1/2"	14
27	6-1694	Hex HD. Bolt, 1/2"-13 UNC x 4 1/2" LG.	8
28	6-0059	Lock Washer, 1/2"	14
29	6-0035	NUT, 1/2-13 UNC, HEX	8
30	6-0295	FLAT WASHER, 5/16" I.D.	8
31	6-0293	HEX HEAD BOLT, 5/16-18UNC x 1" LG.	4
32	6-0674	LOCK WASHER, 5/16 I.D.	4
33	6-0294	HEX NUT, 5/16-18 UNC	4
34	6-0726	SET SCREW, 1/2-13 UNC X 1 LG	4
35	6-0045	Hex HD Bolt, 1/2"-13UNC x 1" LG	6
36	6-0738	FLAT WASHER 3/4" SAE	2
37	6-0115	COTTER PIN, 1/8 DIA X 2 LG	2
38	6-1379	3/4"x5-1/2" LG.	20
39	6-0714	HOSE GUARD	4FT

12.3 TOWER ASSEMBLY

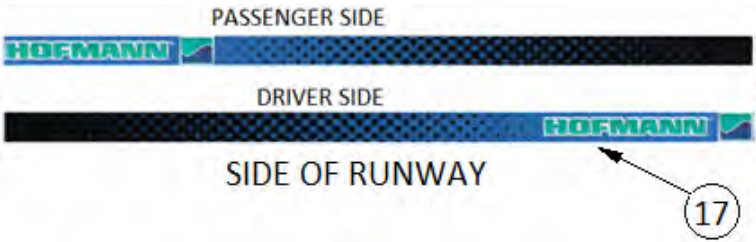
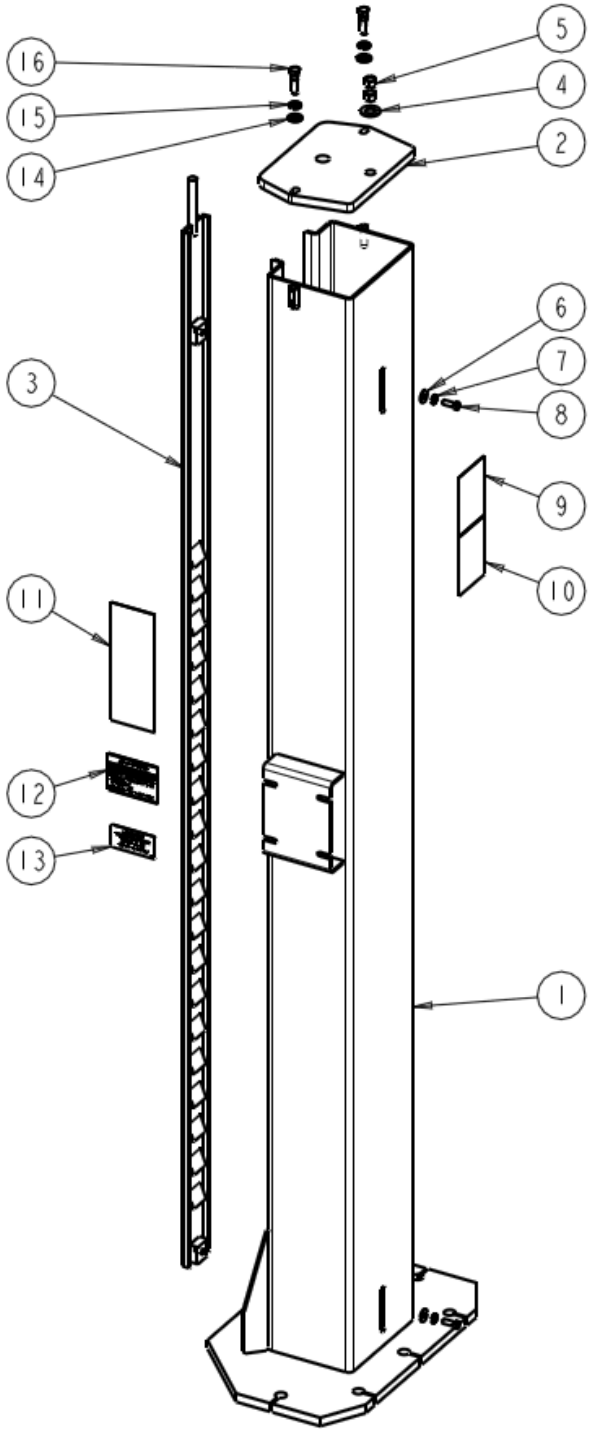

12.4 PARTS LIST – POWER TOWER ASSEMBLY

Item#	Part #	Description	Qty.
1	4-1449	TOWER WELDM'T, POWER	1
	4-1450	TOWER WELDM'T, SLAVE	3
2	2-3026	TOP PLATE - FLAMECUT	4
3	3-0581	SAFETY RACK WELDMENT	4
4	6-1401	FLAT WASHER 5/8"	4
5	6-0673	5/8" HEX NUT, GRADE 8	8
6	6-0625	3/8 ID WASHER REG PLT USS	8
7	6-0058	LOCK WASHER, 3/8"	8
8	6-0668	HHCS, 3/8 UNC X 1, GR.8	8
*9	6-0988_ALI-WL200C	ALI DECAL, CAUTION	1
*10	6-0988_ALI-WL200S	ALI DECAL, NOTICE	1
*11	6-0988_ALI-WL200W	ALI DECAL, WARNING	1
*12	6-4086	WARNING DECAL, DECK LEVELLING	1
*13	6-1637	SAFETY DECAL	1
14	6-0248	Flat Washer, 1/2" ID SAE	8
15	6-0059	Lock Washer, 1/2"	8
16	6-0047	HEX HD BOLT, 1/2-13 X 1-3/4 LG, GR.5, PL	8
17	6-4321	HOFMANN RUNWAY DECAL	1

* NOTE: These part numbers are only applied to the front left (power) tower.

**NOTE: Items 9-11 come as a set, part # 6-0988.

12.5 DECK ASSEMBLY (LEFT SIDE)

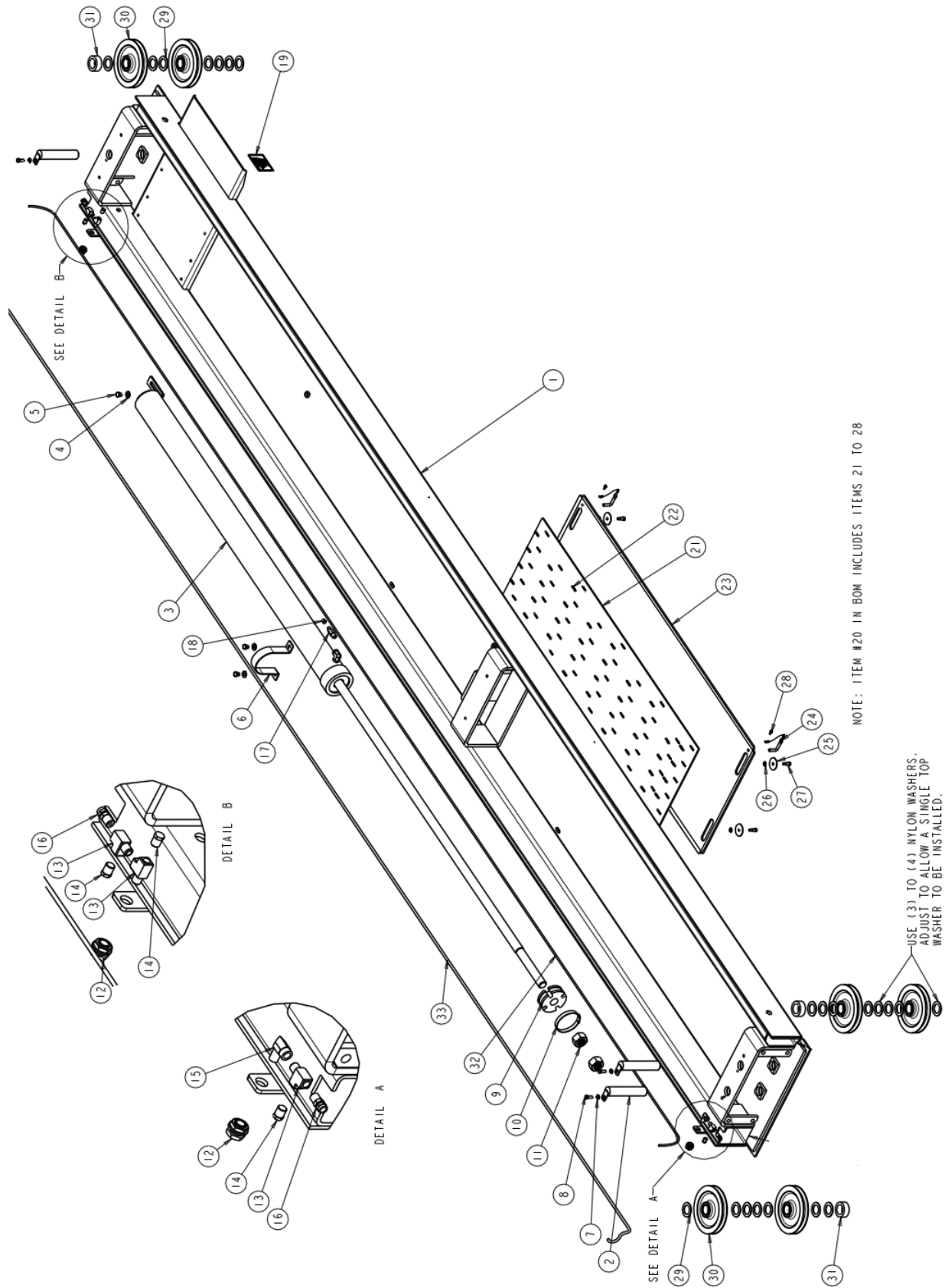

12.6 PARTS LIST – DECK ASSEMBLY (LEFT SIDE)

Item#	Part #	Description	Qty.
1	4-0629	ALIGNMENT DECK WELDMENT LS	1
2	2-1355	DECK SHEAVE PIN	3
3	3-0681	HYDRAULIC CYLINDER ASSEMBLY	1
4	6-0248	Flat Washer, ½" ID SAE	3
5	6-0044	Hex HD Bolt, 1/2" x 1/2"	3
6	1-1747	CYLINDER SLING	1
7	6-0058	LOCK WASHER, 3/8"	3
8	6-0668	HHCS, 3/8 UNC X 1, GR.8	3
9	2-1432	CABLE FLANGE	1
10	6-0665	HOSE CLAMP, 4-1/2"	1
11	6-1644	HEX NUT, 1.375-12 UNF	2
12	6-0713	TERMINAL BOLT, 3/4", SHORT	2
13	6-0014	STREET TEE, 1/4" NPT M-F-F	3
14	6-0282	PLUG, 1/4 NPT, 01CP-4	3
15	6-0015	ELBOW 1/4NPT STREET 90D.	1
16	6-0710	ADAPTER, 3/8" POLY X 1/4"NPT M	2
17	6-1684	VELOCITY FUES, 8 GPM	1
18	6-0021	PLASTIC CAP, 3/8" JIC	1
19	6-1762	Capacity Decal	1
20	3-1115-3	REAR SLIP PLATE ASSEMBLY	1
21	3-0196	BEARING CAGE	1
22	6-0829	DELTRIN BALL, 1/4"	225
23	3-0197	REAR SLIP PLATE	1
24	2-0637	LOCKING PIN ASSEMBLY	2
25	6-0426	FLAT WASHER	4
26	6-0295	FLAT WASHER, 5/16" I.D.	4
27	6-0069	Shoulder Bolt, 3/8" DIA. X 5/8" LG.	4
28	6-1134	SCREW, #12 X 1/2"	2
29	1-0757	NYLON THRUST WASHER	22
30	2-1377	SHEAVE ASSEMBLY	6
31	1-1697	SHEAVE SPACER 1" LG	3
32	8-0141	POLYTUBE, 1/4"	20FT
33	8-0142	POLYTUBE, 3/8"	20FT

12.7 CROSSMEMBER ASSEMBLY

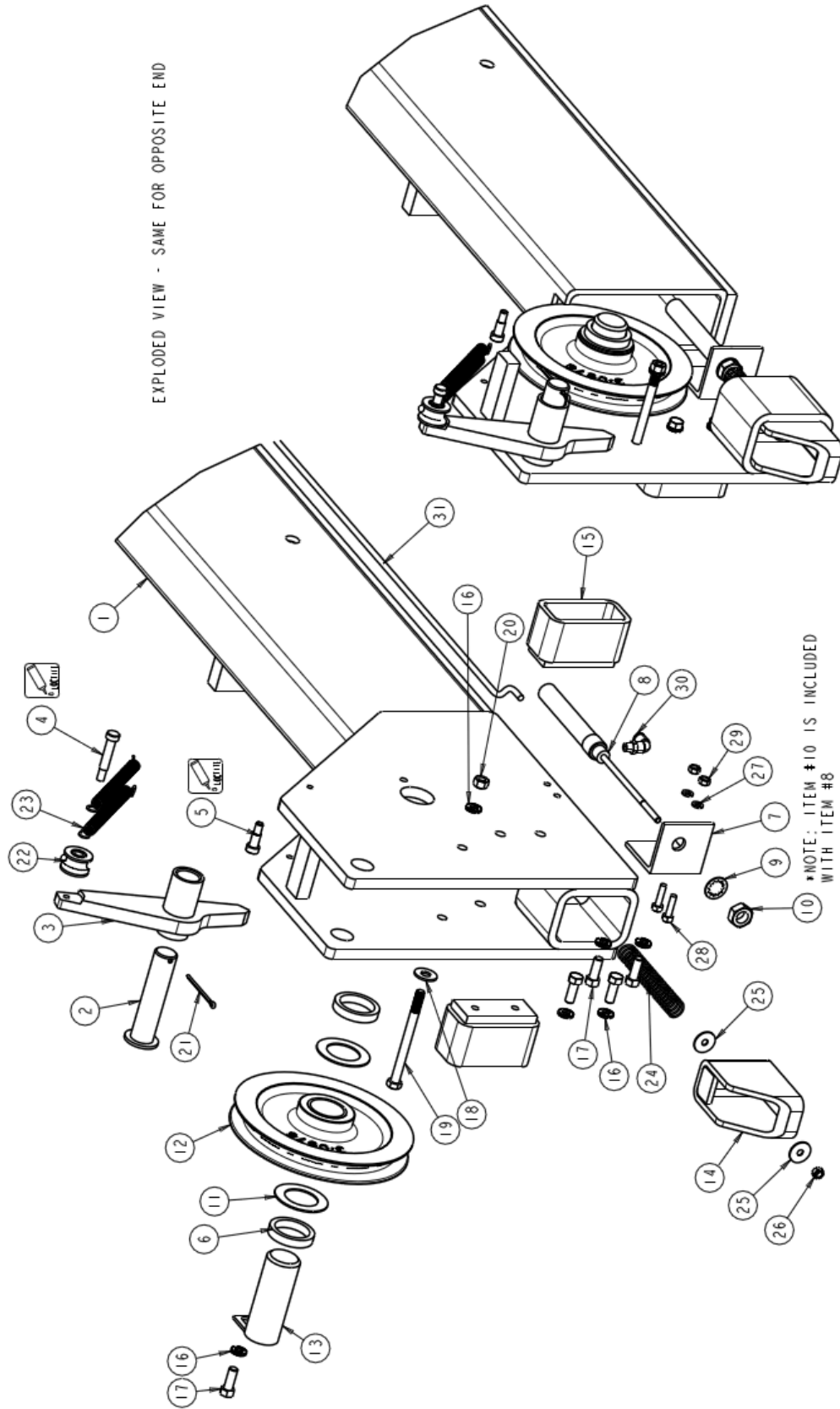

12.8 PARTS LIST – CROSSMEMBER ASSEMBLY

Item#	Part #	Description	Qty.
1	4-0627	FRONT CROSSMEMBER WELDMENT	1
2	1-1744	LOCK SAFETY PIN WELDMENT	2
3	2-1424	SAFETY LOCK WELDMENT	2
4	6-0801	SHOULDER BOLT , 3/8" x 1 1/2" LG.	2
5	6-0069	Shoulder Bolt, 3/8" DIA. X 5/8" LG.	2
6	1-0786	SHEAVE SPACER	4
7	1-1712	AIR CYLINDER BRACKET	2
8	6-0651	AIR CYLINDER	2
9	6-0663	INTERNAL TOOTH WASHER, 5/8"	2
10	6-0662	HEX JAM NUT, 5/8-18UNF	2
11	1-0757	NYLON THRUST WASHER	4
12	2-1377	SHEAVE ASSEMBLY	2
13	2-1356	SHEAVE PIN WELDMENT	2
14	2-1378	SAFETY SHOE WELDMENT	2
15	2-1376	SLIDER BLOCK WELDMENT	4
16	6-0058	LOCK WASHER, 3/8"	12
17	6-0668	HHCS, 3/8 UNC X 1, GR.8	10
18	6-0625	3/8 ID WASHER REG PLT USS	2
19	6-1693	HEX BOLT, 3/8-16UNC X 4.5LG	2
20	6-0034	HEX NUT, 3/8" NC	2
21	6-0115	COTTER PIN, 1/8 DIA X 2 LG	2
22	1-0766	CABLE ROLLER ASSEMBLY	2
23	1-0768	TENSION SPRING	4
24	EAM0139T01A	COMPRESSION SPRING, SAFETY	2
25	6-0626	1/4" WASHER FENDER	4
26	6-1563	1/4-28 UNF LOCK NUT NYLON	2
27	6-0056	LOCK WASHER, 1/4" I.D.	4
28	6-0008	HEXHD. BOLT, 1/4-20 UNC x 1" LG.	4
29	6-0032	Hex Nut, 1/4"-20UNC	4
30	6-0709	SWIVEL ELBOW, 1/4" NYLON TUBE, 1/8" NPT	2
31	8-0141	1/4" POLYTUBE, 130" LONG	1

12.9 CYLINDER ASSEMBLY

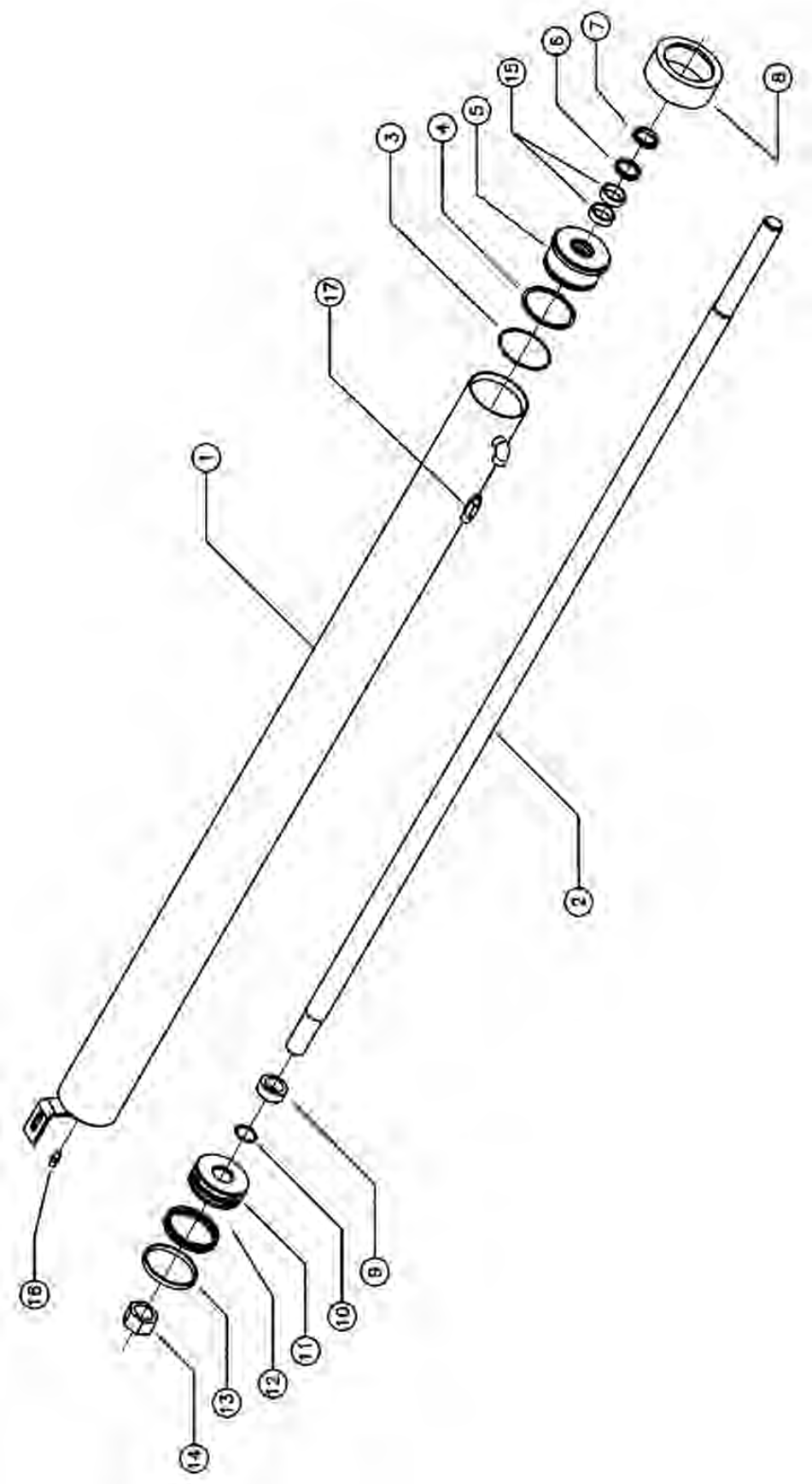

12.10 PARTS LIST – CYLINDER ASSEMBLY

ITEM	QTY.	DESCRIPTION	PART #
1	1	CYLINDER TUBE WELDMENT 4" BORE	2-1345
2	1	PISTON ROD - MACHINED	2-1340
3	1	ORING, 4"OD x 1/8"C/S	6-1633
4	1	BACKUP RING	6-1634
5	1	GLAND	3-0673
6	1	ROD SEAL, 1½"ID x 1 7/8"OD x 1/4"	6-1892
7	1	ROD WIPER, 1½"ID x 1 7/8"OD x 3/16"	6-0001
8	1	TUBE NUT	2-1343
9	1	KEEPER WASHER	1-1689
10	1	ORING, 1 3/8"ID x 1/8"C/S	6-1632
11	1	PISTON	2-1344
12	1	ROD SEAL, 4"OD x 3½"ID	6-1636
13	1	WEAR RING, 4"OD x 3/8"WIDE x 1/8"THK	6-1635
14	1	LOCKNUT, 1 3/8"-12UNF	6-1645
15	2	WEAR RING, 1 3/4"OD x ½"WIDE x 1/8"THK	6-1686
16	1	ADAPTOR, 1/8"NPT-M TO 1/4"JIC-M	6-0280
17	1	VELOCITY FUSE - 8GPM	6-1684

12.11 HYDRAULIC AND AIR KIT

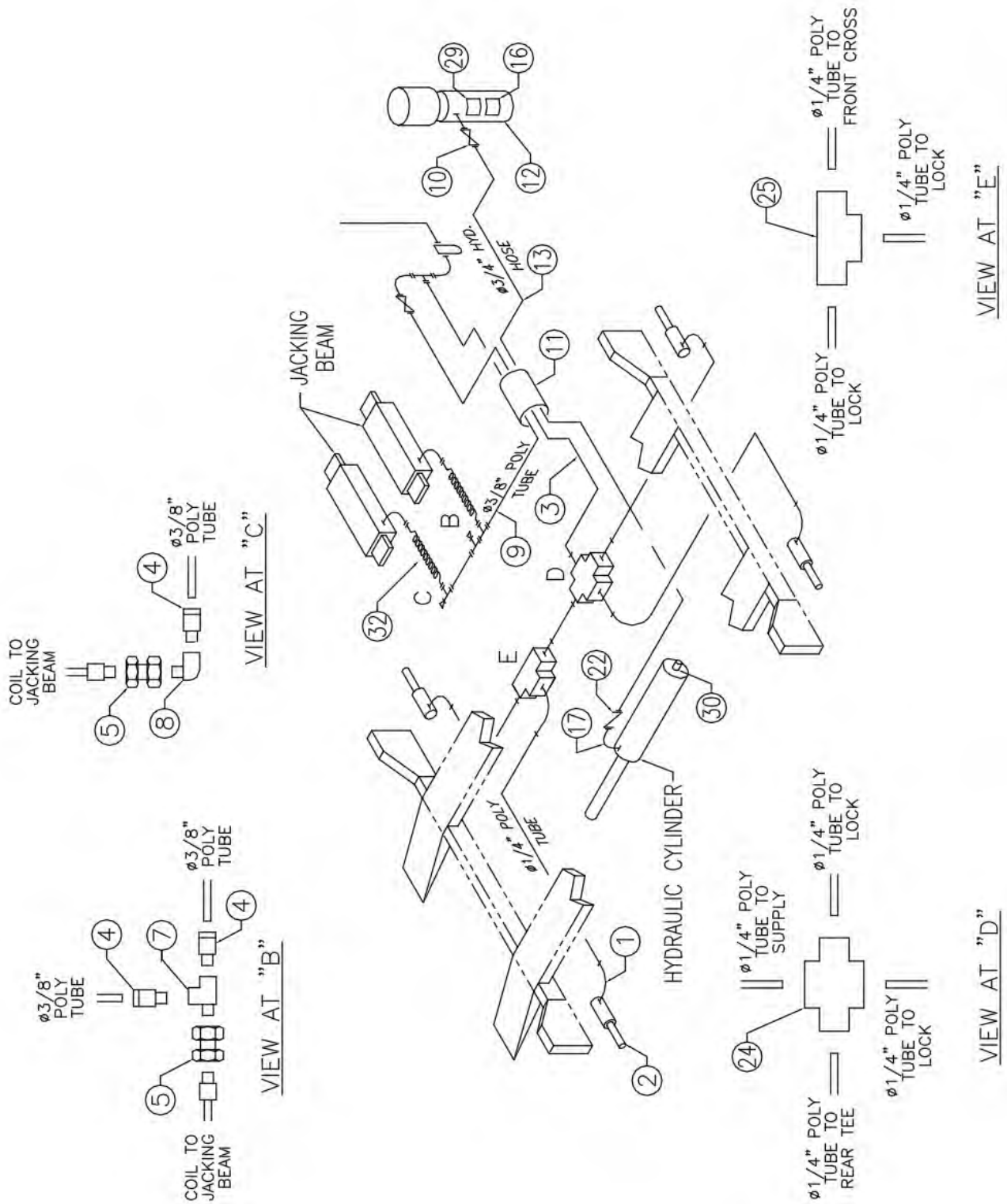

12.12 PARTS LIST – HYDRAULIC AND AIR KIT

ITEM	QTY.	DESCRIPTION	PART #
1	8	90° ELBOW, 1/8" NPT x 1/4" POLYTUBE	6-0709
2	4	AIR CYLINDER	6-0651
3	10FT	1/4" DIA. POLY TUBE	6-1396
4	3	ADAPTER, 3/8" POLY TUBE x 1/4" NPT	6-0710
5	2	TERMINAL BOLT, 3/4"	6-0713
7	1	1/4" NPT STREET TEE	6-0014
8	1	1/4" NPT STREET ELBOW	6-0015
9	10FT	3/8" DIA. POLY TUBE	6-1400
10	1	FLOW CONTROL	6-1691
11	4FT	HOSE GUARD	6-0714
12	1	POWER PACK 230V/1 PH	6-1695
13	1	HYD.HOSE ASS'Y, 3/8" JIC FEMALE, 16FT LONG	6-1692
14	3	CABLE TIE	6-0731
16	1	"NOTICE" DECAL	6-0594
17	1	90° ELBOW, 1/4" NPT M x 3/8" NPT F	6-0796
22	1	VELOCITY FUSE 8GPM	6-1684
24	1	1/4" PUSHLOCK CROSS	6-3869
25	1	1/4" PUSHLOCK TEE	6-2971
29	1	"LIFT OPERATION" DECAL	6-0593
30	1	ADAPTER, 1/8" NPT M X 1/4" JIC M	6-0280
32	1	RECOIL HOSE	6-0337

12.13 FILTER / REGULATOR / LUBRICATOR ASSEMBLY

Complete Assembly: 2-3005

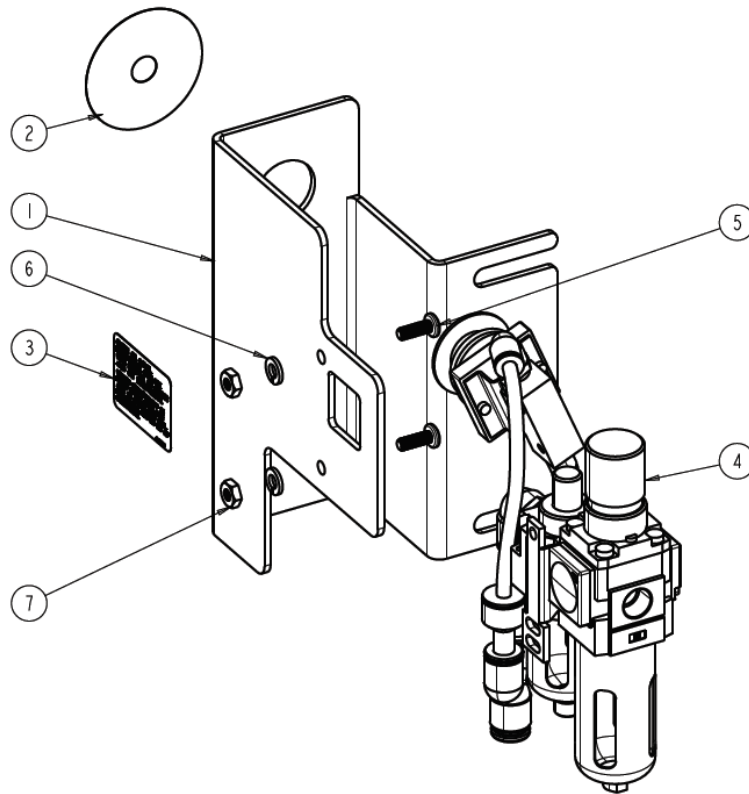

ITEM	QTY	DESCRIPTION	PART #
1	1	MOUNTING BRACKET, FRL	2-3022
2	1	DECAL, SAFETY RELEASE	6-3558
3	1	DECAL, OIL LEVER	6-3696
4	1	FRL ASSEMBLY W/ RELEASE BUTTON, contains:	2-3021
	1	FILTER/REGULATOR/LUBRICATOR ASS'Y	6-4142_FM
	1	90 DEG. ELBOW, 1/4"NPT M - 3/8" POLY	6-3010
	1	AIR VALVE & PUSHBUTTON	6-1777
	1	SWIVEL ELBOW, 1/8"NPT M - 1/4" POLY	6-0709
	1	PUSHLOCK UNION, 3/8" POLY	6-4214
	1	REDUCER, 3/8" STEM - 1/4" POLY	6-3731
	1	PUSHLOCK UNION, 1/4" POLY	6-3202
	1	ADAPTER, 1/8" NPT M - 1/4" POLY	6-0708
5	2	PHMS, #12-24 X 5/8" LG	6-4145
6	2	LOCK WASHER, 1/4" ID	6-0056
7	2	HEX NUT, #12-24	6-4146

12.14 CABLE ROUTING

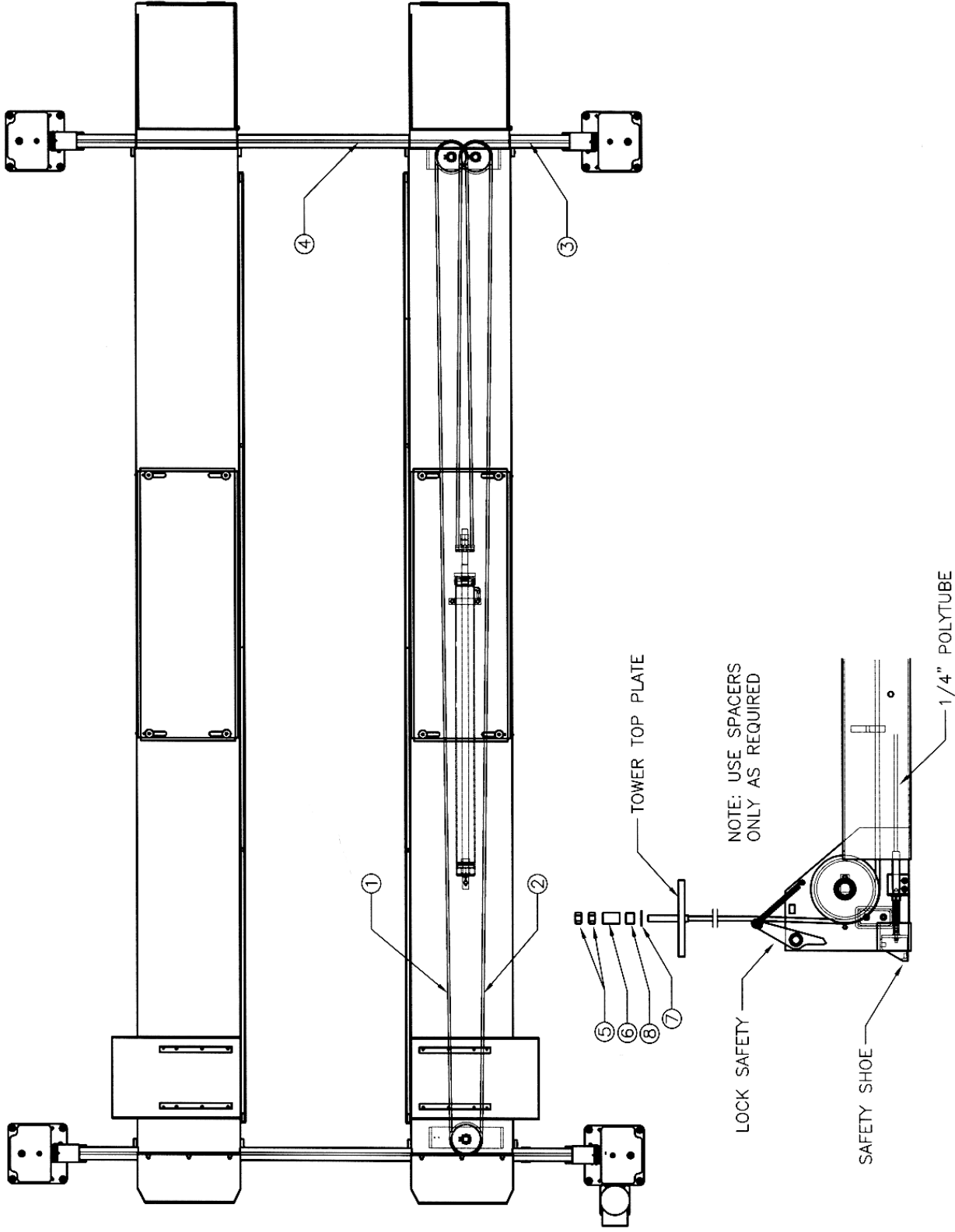

12.15 PARTS LIST – CABLE ROUTING

ITEM	QTY.	DESCRIPTION	PART #
1	1	CABLE ASSY. 407.5" - FRONT LEFT	2-1360
2	1	CABLE ASSY. 473.5" - FRONT RIGHT	2-1361
3	1	CABLE ASSY. 162" - REAR LEFT	2-1362
4	1	CABLE ASSY. 228" - REAR RIGHT	2-1363
5	8	HEX NUT, 7/8"-14UNF GR5	6-0724
6	4	CABLE SPACER, 2"LG	1-0800
7	4	FLAT WASHER, 7/8"ID	6-0725
8	4	CABLE SPACER, 1"LG	1-0801

12.16 POWER PACK ASSEMBLY

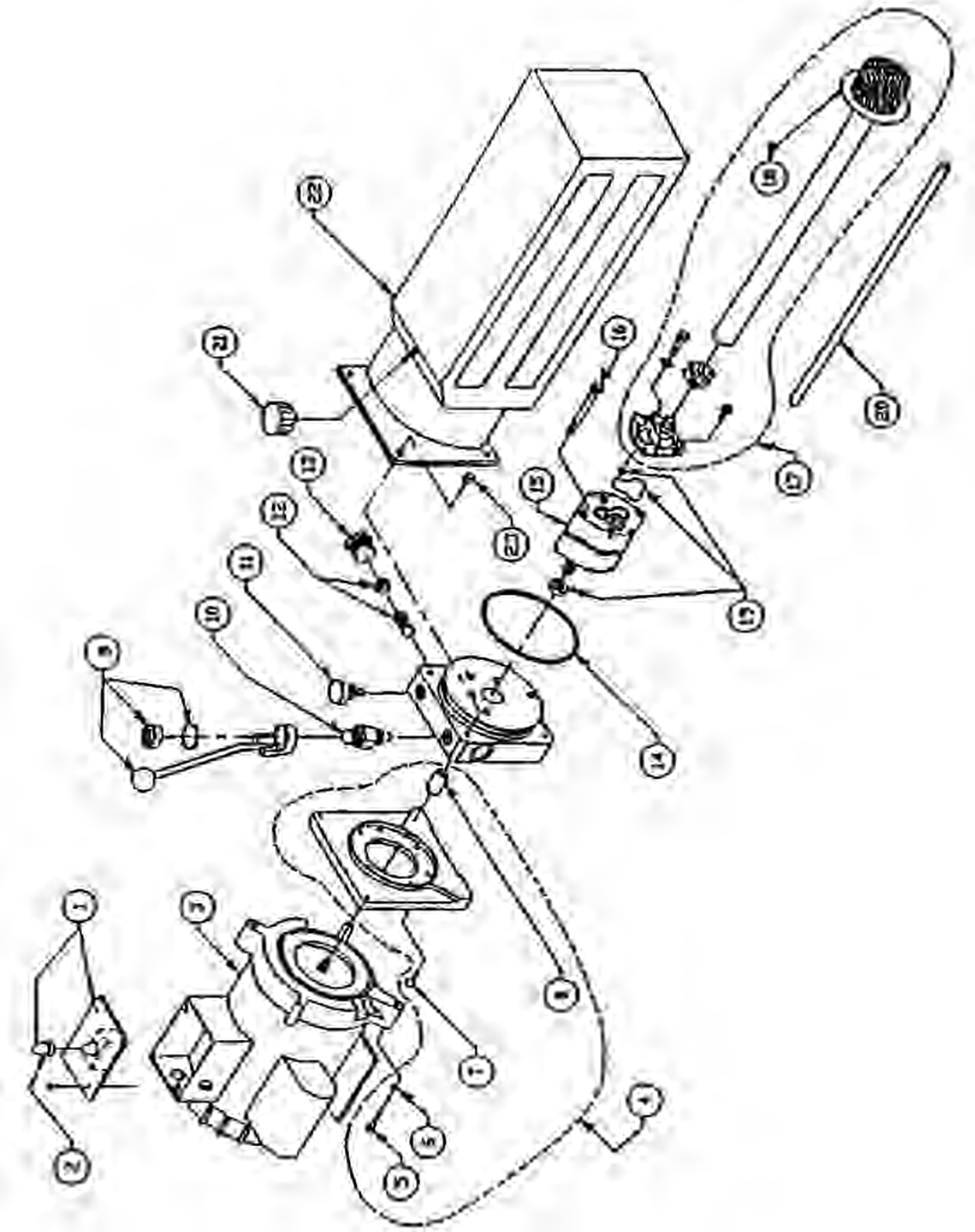

12.17 PARTS LIST – POWER PACK

ITEM	QTY.	DESCRIPTION	PART #
1	1	MICROSWITCH AND WIRING ASSEMBLY, 1PH	6-0881
2	1	MICROSWITCH BOOT	1277-AA
3	1	MOTOR, 230V AC, 1 PHASE, 60 HERTZ 3HP	6-1959
4	1	MOTOR ADAPTER KIT	0-0197
5	4	SOCKET HD.CAP SCW. 1/4"-20UNC X 1 5/8"LG.	6-1085
6	4	LOCK WASHER, 1/4" I.D.	6-0056
7	4	ALLEN FLAT HD.SCW. 1/4"-20UNC X 3/4"LG.	6-1086
8	1	COUPLING	6-0774
9	1	RELEASE BRACKET & HANDLE ASSEMBLY	6-0776
10	1	VALVE CARTRIDGE RELEASE	6-0880
11	1	VALVE CARTRIDGE CHECK	6-1087
12	1	FIXED RELIEF VALVE ASSEMBLY (RV 19)	6-1319
13	1	RELIEF VALVE CAP	6-1089
14	1	RESERVOIR "O" RING	6-0875
15	1	PUMP ASSEMBLY	6-1688
16	2	PUMP MOUNTING BOLT	6-1090
17	1	INLET PLUMBING KIT	0-0198
18	1	INLET HOSE / FILTER ASSEMBLY	6-0786
19	1	PUMP "O" RING KIT	0-0199
20	1	RETURN TUBE	6-0783
21	1	BREATHER FILLER CAP	6-0784
22	1	RESERVOIR	6-2828
23	4	RESERVOIR SCREW	6-1091

CAUTION

ALL SAFETY LADDERS USED ON 4-POST LIFTS ARE PRELOADED.

REMOVING THE BOLT HOLDING THE BOTTOM PORTION OF THE SAFETY LADDER WITHOUT PROPER PRECAUTIONS CAN RESULT IN INJURY.

PLEASE CONTACT CUSTOMER SERVICE FOR PROPER REMOVAL INSTRUCTIONS.

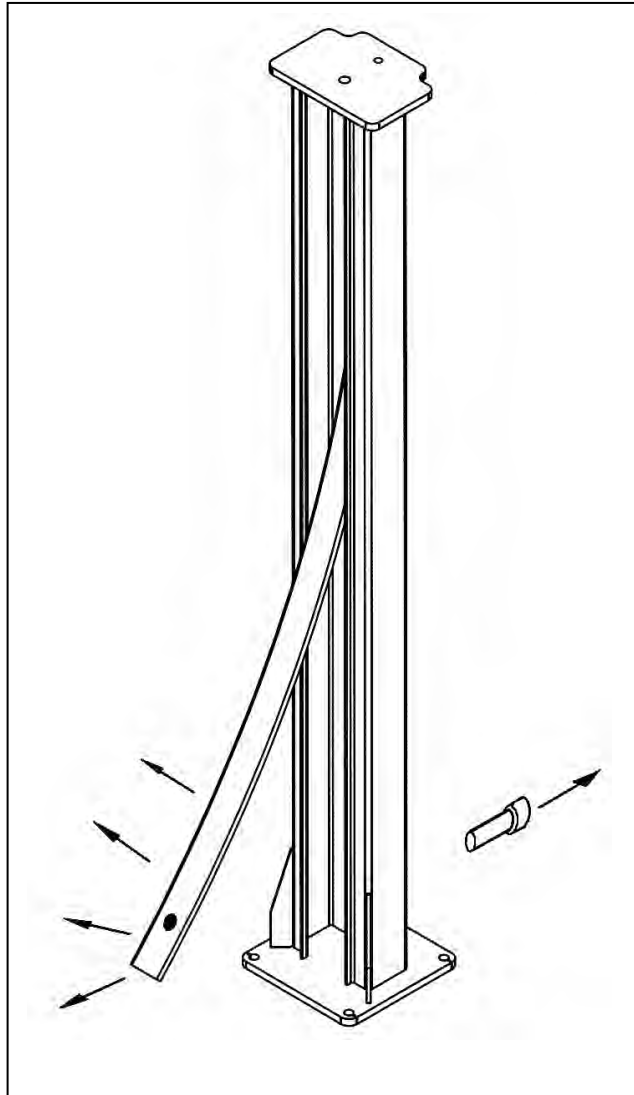

13.0 AVAILABLE ACCESSORIES

Hydraulic Jack Beams			
	Premium Air / Hydraulic Jack Beam		Standard Air / Hydraulic Jack Beam
4500 lb, 6000 lb, 7000 lb		6000 lb, 7000 lb	
Other Accessories			
	Drive-On Ramp Extension for Low Profile Vehicle (set of 2)		Air Outlet Kit (Factory Installed)
	Sliding Waste Collection Oil Tank 26 gal.		Drive-thru Kit (Quad Rack)
	Front Turning Radius Plates (set of 2)		Alignment Pan Cover, 4-Post
	Stainless Steel Turnplates		Rollback Kit (for Stainless Steel Turnplates)
	Air / Electric Service Station for 2-Post & 4-Post		Rear Slip Plate Refurb Kit - Stainless Steel Base (24" Decks Only - set of 2)
NO PICTURE AVAILABLE	Roll Forward Kit (4-Post)		

Accessories may not be available for all models. Contact supplier for availability and part numbers.