

# HOFMANN

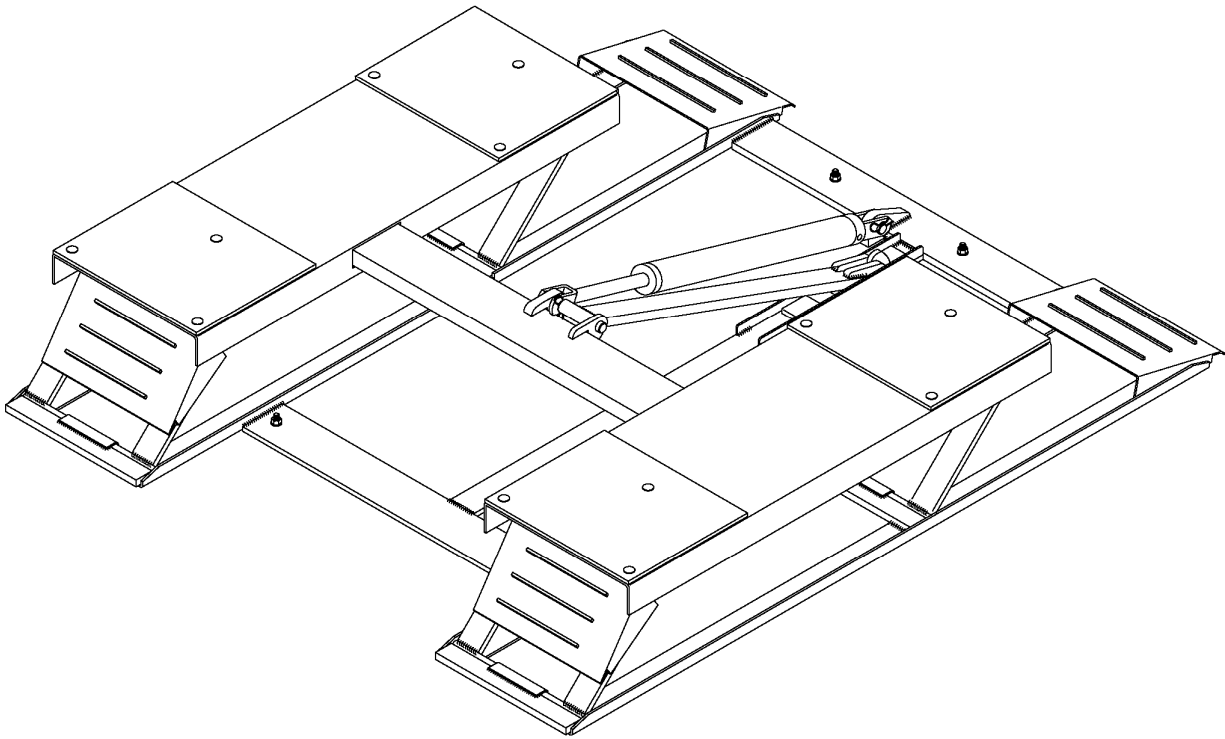

## INSTALLATION and OPERATION MANUAL



### 6K LOWRISE LRE6024

**READ THIS INSTRUCTION MANUAL THOROUGHLY  
BEFORE INSTALLING, OPERATING, SERVICING OR  
MAINTAINING THE LIFT. SAVE THIS MANUAL.**



309 Exchange Avenue • Conway, AR 72032  
(800) 251-4500 • (501) 505-2662  
Fax (501) 450-2085 • [www.hofmann-usa.com](http://www.hofmann-usa.com)



6500 Millcreek Drive • Mississauga, ONT L5N 2W6  
(800) 267-2185  
Fax (905) 821-2073 • [www.hofmann.ca](http://www.hofmann.ca)

JUN 2010 REV.- 6-3652

# TABLE OF CONTENTS

1.0 SAFETY AND OPERATING INSTRUCTIONS .....	3
2.0 SAFETY WARNING DECALS.....	5
3.0 GENERAL SPECIFICATIONS .....	6
4.0 SHIPPING CONTENTS.....	7
5.0 TOOLS REQUIRED FOR INSTALLATION.....	7
6.0 INSTALLATION INSTRUCTIONS.....	8
6.1 BAY LAYOUT – SURFACE MOUNT.....	9
6.2 UNPACKING THE LIFT.....	10
7.0 HYDRALLIC CONNECTIONS .....	10
7.1 ANCHORING PROCEDURES .....	10
8.0 BLEEDING PROCEDURES.....	12
8.1 CHECK OF ASSEMBLED LIST.....	12
8.2 OPERATION TEST WITH VEHICLE.....	12
9.0 LIFT OPERATION .....	13
9.1 RAISING THE LIFT .....	13
9.2 LOWERING THE LIFT.....	13
10.0 RECOMMENDED MAINTANANCE .....	13
10.1 MAINTANANCE SCHEDULE.....	14
11.0 TROUBLE SHOOTING.....	15
12.0 LIFT ASSEMBLY .....	16
12.1 LIFT PARTS LIST .....	16
13.0 POWER PACK ASSEMBLY .....	17
13.1 POWER PACK PARTS LIST .....	18
14.0 AVAILABLE ACCESSORIES .....	19

**This lift requires at least 2 persons for assembly / installation.**

## **1.0 SAFETY AND OPERATING INSTRUCTIONS**

When using this lift, basic safety precautions should always be followed, including the following:



1. Thoroughly read all instructions in this manual and on the lift before installing, operating, servicing or maintaining the lift.
2. Inspect the lift daily. Do not operate lift if it malfunctions or if problems have been encountered.
3. Never attempt to overload the lift. The manufacturer's rated capacity is shown on the identification label. Do not override the operating controls or the warranty will be void.
4. Only trained and authorized personnel should operate the lift. Do not allow customers or bystanders to operate the lift or be in the lift area.



5. **Caution! Never work under the lift unless the mechanical safety locks are engaged.**
6. Always keep the lift area free of obstruction and debris. Grease and oil spills should always be cleaned up immediately.
7. Never lift a vehicle with passengers inside.
8. Before lowering the lift check the area for any obstructions.
9. To protect against risk of fire, do not operate lift in the vicinity of open containers of flammable liquids.
10. Adequate ventilation should be provided when working on internal combustion engines.
11. Do not remove hydraulic fittings while under pressure.

**SAVE THESE INSTRUCTIONS**

For additional safety instructions regarding lifting, lift types, warning labels, preparing to lift, vehicle spotting, vehicle lifting, maintaining load stability, emergency stop procedures, vehicle lowering, lift limitations, lift maintenance, good shop practices, installation, operator training, and owner/employer responsibilities, please refer to "Lifting It Right" (ALI/SM) and "Safety Tips" (ALI/ST).

For additional instructions on general requirements for lift operation, please refer to "Automotive Lift-Safety Requirements For Operation, Inspection and Maintenance" (ANSI/ALI ALOIM).

Installation shall be performed in accordance with ANSO/ALI ALIS, Safety Requirements for Installation and Service of Automotive Lifts.



**ATTENTION!** This lift is intended for indoor installation only. It is prohibited to install this product outdoors. Operating environment temperature range should be 41 – 104 °F (5 – 40 °C). Failure to adhere will result in desertification, loss of warranty, and possible damage to the equipment.

+ 070126-Quadra-WLSIA01

## SAFETY INSTRUCTIONS

If attachments, accessories or configuration modifying components that are located in the

load path, affect operation of the lift, affect the lift electrical listing or affect intended vehicle accommodation are used on this lift and, if they are not certified for use on this lift, then the certification of this lift shall become null and void. Contact the participant for information pertaining to certified attachments, accessories or configuration modifying components.



[www.autolift.org](http://www.autolift.org)

©2007 by ALI, Inc.

ALI / WLSIA01

## 2.0 SAFETY WARNING DECALS

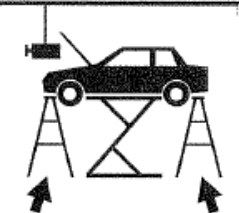
Be sure the operator is aware and understands all safety warning labels and follows them accordingly.

<p><b>⚠ WARNING</b></p>  <p>Position vehicle with center of gravity midway between adapters. ©</p>	<p><b>⚠ WARNING</b></p>  <p>Remain clear of lift when raising or lowering vehicle. ©</p>	<p><b>⚠ WARNING</b></p>  <p>Keep feet clear of lift while lowering. ©</p>	
<p><b>⚠ WARNING</b></p>  <p>Clear area if vehicle is in danger of falling. ©</p>	<p><b>⚠ WARNING</b></p>  <p>Avoid excessive rocking of vehicle while on lift. ©</p>	<p><b>⚠ WARNING</b></p>  <p>Keep clear of pinch points when lift is moving. ©</p>	<p>The messages and pictographs shown are generic in nature and are meant to generally represent hazards common to all automotive lifts regardless of specific style.</p> <p>Funding for the development and validation of these labels was provided by the Automotive Lift Institute, PO Box 33116 Indianapolis, FL, 32903.</p> <p>They are protected by copyright. Set of labels may be obtained from ALI or its member companies.</p> <p>© 1992 by ALI, Inc. ALI/WL300csw</p>
<p><b>⚠ CAUTION</b></p>  <p>Use vehicle manufacturer's lift points. ©</p>	<p><b>⚠ CAUTION</b></p>  <p>Always use safety stands when removing or installing heavy components. ©</p>	<p><b>⚠ CAUTION</b></p>  <p>Authorized personnel only in lift area. ©</p>	<p><b>⚠ CAUTION</b></p>  <p>Lift to be used by trained operator only. ©</p>
<p><b>SAFETY INSTRUCTIONS</b></p>  <p>Proper maintenance and inspection is necessary for safe operation. ©</p>	<p><b>SAFETY INSTRUCTIONS</b></p>  <p>Do not operate a damaged lift. ©</p>	<p><b>SAFETY INSTRUCTIONS</b></p>  <p>Read operating and safety manuals before using lift. ©</p>	<p>Power Unit: Secure placard near lift controls.</p>  <p>Lift Control Console: Secure placard in an accessible location.</p> 

### 3.0 GENERAL SPECIFICATIONS

Capacity:	6000 lbs.	2722 kg
Overall Width:	72.5"	1842 mm
Overall Length:	83"	2108 mm
Lowered Height:	3-3/8"	86 mm
Raised Height:	22"	559 mm
Power Requirements:	115 Volts AC, 1 Ph., 60 Hz.	

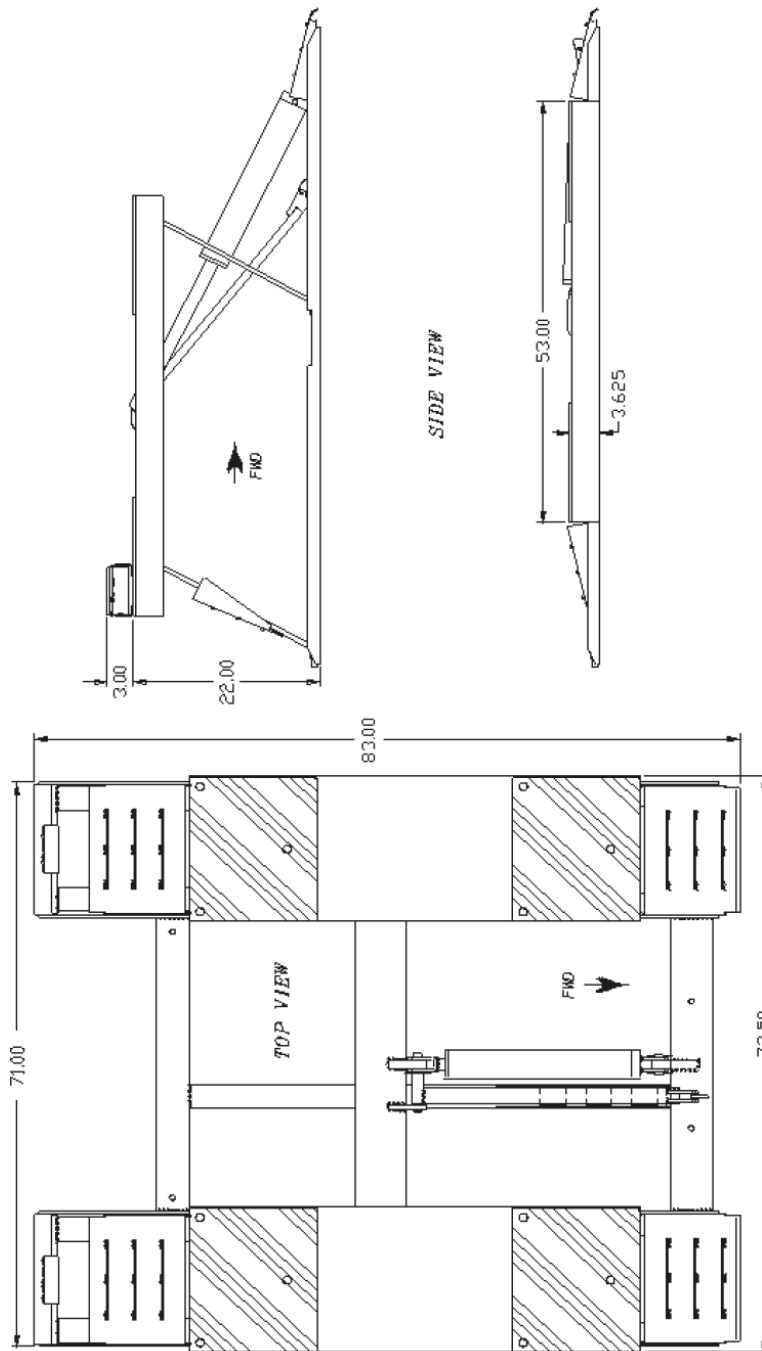

**Figure 1 - Lift Dimension**

## 4.0 SHIPPING CONTENTS

**Overall Weight:** 739lb / 335kg

- 1 – Lifting frame assembly with rubber pads and cylinder
- 2 – Pump and parts box including:
  - 1 – Hydraulic 115 Volt pumping unit & oil reservoir
  - 1 – Pumping unit mounting stand with nuts and bolts
  - 1 – Eleven foot length of hydraulic hose
  - 4 – ¾" x 5 ½" cement anchor bolts
  - 4 – Height adapters
  - 1 – ALI manual "Lifting it Right"
  - 1 – Automotive lift safety tips
  - 1 – Installation and Operation manual

### Missing Parts

It is important to notify the delivery carrier immediately if any parts are damaged or missing from shipment.

## 5.0 TOOLS REQUIRED FOR INSTALLATION

- 16ft. Measuring Tape
- Chalk Line
- Rotary Hammer Drill
- ¾" diameter Masonry Drill Bit
- Hammer
- SAE Wrenches and Ratchet Set
- 2ft. Level
- 4ft. Level
- Crow Bar
- 12ft. Step Ladder
- Side Cutters
- Screwdrivers
- 4" x 4" Wooden Blocks (for unpacking)

## 6.0 INSTALLATION INSTRUCTIONS

When the lift arrives on site, please read the owner's manual completely and make sure the installation instructions are fully understood. Check the contents of the hardware and accessory boxes to make sure no parts are missing and no freight damages exist before starting installation. Gather all the tools listed above and make sure the installation instructions are fully understood before commencing with the installation.

**IMPORTANT: It is the user's responsibility to provide a satisfactory installation area for the lift. Lifts should only be installed on level concrete floors with a minimum thickness of five 4-1/4" or 115 mm. Concrete must have a steel reinforcing with a minimum strength of 3000 psi or 21 MPa and should be aged thirty (30) days prior to installation. Maximum slope must not exceed 1/16" per foot. Always pay special attention to the condition of the concrete such as age, cracking, chipping, and levelness. Please consult the architect, contractor or engineer if doubt exists as to the strength and feasibility of the floor to enable proper lift installation and operation.**

It is the user's responsibility to provide all wiring for electrical hook-up prior to installation and to insure that the electrical installation conforms to local building codes. Where required, it is the user's responsibility to provide an electrical isolation switch located in close proximity to the lift that will enable emergency stop capability and isolate electrical power from the lift for any servicing requirements.



## 6.1 BAY LAYOUT – SURFACE MOUNT

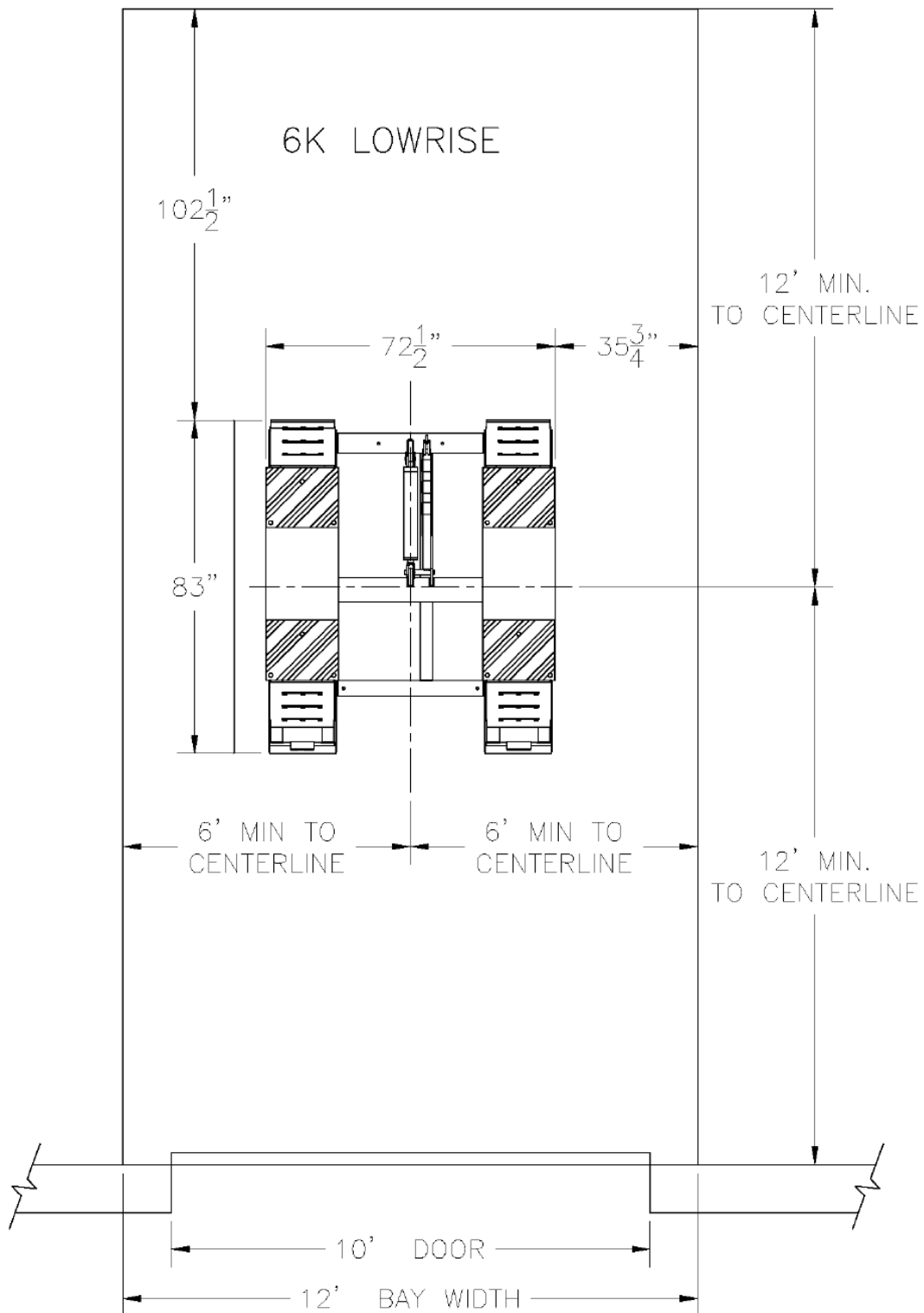

**Figure 2 - Bay Layout – Surface Mount**

## 6.2 UNPACKING THE LIFT

Remove the metal strapping from the main structure package and slide the lift shipping skid. Open the accessory box and check the contents of the box.

1. Position unit on a flat floor allowing a minimum of 6 feet from center of lift to side obstructions and 12 feet from center of lift to front or rear obstructions. (Lift cylinder is on front end of lift.) Recommended overhead clearance is a minimum 97 inches ceiling providing 25 inches for the maximum lift height and 6 feet for the supported vehicle. For vehicles taller than 6 feet it is recommended that the user provides additional overhead clearance or a shut off mechanism to stop the lift from raising the vehicle too high.
2. Remove pumping unit from box and install on pump stand.

## 7.0 HYDRALLIC CONNECTIONS

**NOTE: When working with hydraulics it is important to keep all components clean.**

1. Select a position best suited for the power pack.
2. Remove the breather filler cap and fill with 11 liters / 3 Gal. of ISO 32 10 weight hydraulic oil.
3. Reinstall the breather filler cap onto the Power Unit.
4. Connect the 90° elbow fitting (9/16" JIC-M, 3/8" JIC-M) with 'O' ring, to the hydraulic outlet port on the valve assembly of the power pack. The 90° elbow fitting is located in a hardware kit.
5. Connect 11' (3353 mm) long hydraulic hose (female end) to the opposite end of the 90° elbow fitting.
6. Locate the opposite (male) end of the 11' (3353 mm) long hydraulic hose. Connect to the inlet port of the lift, which is located on the center hydraulic cylinder.
7. Tighten the hydraulic line in place so that it runs along the floor giving it a low profile.

## 7.1 ANCHORING PROCEDURES

**NOTE: Check operation of lift (up/down) before anchoring the lift.**

1. Raise the lift to full height and ensure there are no differences.
2. Mark bolt holes on concrete floors. (Eight 3/4" x 5 1/2" wedge anchor bolts are provided.)
3. Move unit aside. Using a rotary hammer drill and a 3/4" concrete bit, drill through the floor at each anchor bolt location. Make sure that the 3/4" concrete drill bit is in good condition.

4. Clean out the drilling dust from the holes and move unit into position over bolt holes.
5. Assemble the nut and washer onto the supplied  $\frac{3}{4}$ " x  $5\frac{1}{2}$ " long wedge anchor bolts. A minimum of six threads must be visible below the surface of the nut.
6. Hammer in the anchors until they make contact with the base plate. **Hand tighten all anchor bolts.** Remove any bolt assembly that does not grip concrete firmly and open expansion sleeve before reinstalling.
7. Inspect to make certain lift sits firmly on floor. There should be no twisting or rocking motion in the base unit.
8. Torque all anchor bolts to 75 ft-lbs.
9. Position the power pack in the final desired location. Using a rotary hammer drill and a  $\frac{1}{4}$ " concrete bit, drill four (4) holes and anchor the power pack stand to the floor using anchor bolts located in the hardware kit.
10. Use the line covers to protect all cables, hoses, and wiring running to the lift. Using a rotary hammer drill and a  $\frac{1}{4}$ " concrete bit, drill and anchor the line covers using the nail in anchors located in the hardware kit.
11. With all anchor bolts torqued as specified operate the lift checking its full operation.

If anchor bolts do not tighten to 75 ft-lbs OR project more than  $2\frac{1}{4}$ " above the concrete surface, the concrete should be replaced by an appropriate concrete pad. (Consult Product Manufacturer / Supplier for further details.)

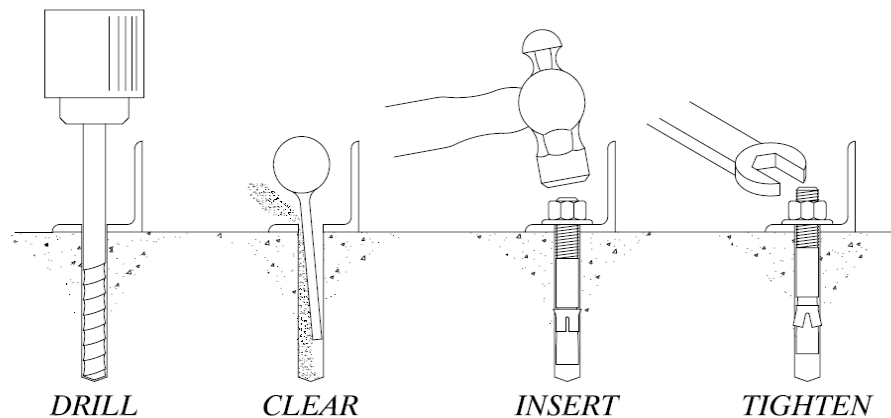

**Figure 3 - Anchoring Steps**

## **8.0 BLEEDING PROCEDURES**

1. Press the up control button and raise the lift 10" (254mm) above the ground.
2. Lower the lift to the ground and hold the down button until lift fully reaches the ground.
3. Repeat these steps 3-4 times to completely bleed the system of air. Check the lift for hydraulic leaks at all connections.
4. After bleeding, it is recommended that the filter assembly fitting (between the hydraulic hose and the power pack) be cleaned. Place the fitting on a workbench and use an air gun to blow through the filter in the opposite direction to flow from the lift.

## **8.1 CHECK OF ASSEMBLED LIST**

1. Check for hydraulic leaks. \_\_\_\_
2. Ensure all safety lock mechanisms are working correctly. \_\_\_\_
3. Re-check level of decks. \_\_\_\_
4. Check all fasteners, tighten if necessary. \_\_\_\_
5. Operate lift to full stroke then lower to ground while checking for proper functionality. \_\_\_\_
6. Ensure Customer Care Kit is complete and given to operator. \_\_\_\_
  - a. Operation Manual \_\_\_\_
  - b. ANSI / ALI Lift It Right Manual \_\_\_\_
  - c. ANSI / ALI Safety Tip CARD \_\_\_\_
  - d. ANSI / ALI ALIS safety Requirements for Installation and Service of Automotive Lifts \_\_\_\_
  - e. ANDI / ALI Quick Reference Guide \_\_\_\_
7. Train end user on operation of the lift. \_\_\_\_

## **8.2 OPERATION TEST WITH VEHICLE**

1. Lower lift to ground.
2. Drive vehicle on to lift such that the lift's contact frame is properly aligned with the manufacturer's recommended lifting points for that vehicle.
3. Raise lift to and lower onto first, second, and third lock positions during full rise to ensure all locks are working correctly.
4. Check lowering speed and smooth decent rate.
5. Lower lift to ground and drive vehicle off lift.

If any problems occur during the final checkout or operation of the lift please contact customer service at 1-800-268-7959.

## 9.0 LIFT OPERATION

Operators of this lift should be trained by authorized personnel.

### Before Lifting:

1. After making certain lift is in fully lowered position, drive car slowly over cushions until front wheels are no more than a few inches in front of superstructure. Rear engine vehicles should be positioned with rear wheels close to superstructure. Do not turn steering wheel while tires are crossing cushions.
2. Check to make certain car is fairly well centered left to right on lift.

### 9.1 RAISING THE LIFT

1. Hold toggle switch on pumping unit in "ON" position until locking leg drops onto one of the three lifting height locking positions.
2. Rock vehicle to check for stability.

### 9.2 LOWERING THE LIFT

1. After making certain lifting area is clear of people, electric cords, hoses, etc., raise lift to full height to disengage locking device.
2. Press valve slowly until lift is in full contact with floor.

### After Lowering:

Drive car off lift without turning steering wheel while tires are crossing cushions.

## 10.0 RECOMMENDED MAINTANANCE

### Inspect Regularly for:

- a. Overload cracks in welds and metal fatigue.
- b. Misalignment of working parts.
- c. Hydraulic leaks.
- d. Low fluid level in pump reservoir. **DO NOT** use automatic transmission fluid. Use only petroleum based ISO 32 10 weight hydraulic oil.
- e. Lubricate all moving parts.
- f. Check locking latch for smooth and proper operation.

## 10.1 MAINTANANCE SCHEDULE

### Daily:

1. Check all hydraulic lines and fittings for pinch points , damage , cracks or leaks
2. Check all electrical wiring for pinch points , cracks or damage
3. Check all moving parts for uneven or excessive wear
4. Repair or replace all damaged, defective, worn or broken components immediately.
5. Check the telescopic arms for movement. Clean any grease or oil from the lifting adapters.
6. Raise and lower the lift at the beginning of each shift, without a vehicle on, to verify the lift is leveled and operating properly.

### Weekly:

Check and adjust hydraulic level.

### Every Two Months:

1. Clean and re-grease hinge pins.

### Every Year:

Inspect lift as per Automotive Lift Operation, Inspection and Maintenance (ALOIM).

### Every Two years:

Change hydraulic fluid.

### LUBRICATION:

Where grease is required > multi-purpose lithium grease.

Where lubricating oil is required > multi-purpose SAE 30 lubricating oil.

Where hydraulic oil is required > ISO 32 10W - non detergent hydraulic oil.

**NOTE: If the lift locks, while in the fully raised position this will indicate that the hydraulic system has not been inspected or maintained as recommended. This is a safety back-up system. If you are unclear call your local representative immediately.**

## 11.0 TROUBLE SHOOTING

- 1) Motor does not run:
  - A. Breaker tripped or fuse blown.
  - B. Motor thermal overload tripped. Wait for overload to cool.
  - C. Defective control switch. Replace switch.
  - D. Faulty wiring connections. Call electrician.
- 2) Motor runs but the lift will not hold a load.
  - A. A foreign object under check valve. Push handle down and push "raise" switch. Foreign matter should release under pressure.
  - B. Remove check valve. Clean ball and seat and replace the nut.
  - C. Oil level low, check oil reservoir. With lift cylinder (cylinders) in the down position, pump reservoir should be full.
- 3) Motor runs but the lift picks up partial load only.
  - A. Lift is overloaded. Check capacity of lift and weight of vehicle.
  - B. Relief valve setting is too low. Remove back hex cap on pump and adjust valve clockwise.
  - C. Hydraulic seals damaged (call customer service for instructions 1-800-266-7959).
- 4) Oil blows out of breather.
  - A. Oil reservoir overfilled.
  - B. Lift lowered too quickly while under heavy load.
- 5) Lift makes groaning sound when raising or lowering.
  - A. Bleed cylinder manually.
  - B. Add an ounce of oil to the air side of the piston.

## 12.0 LIFT ASSEMBLY

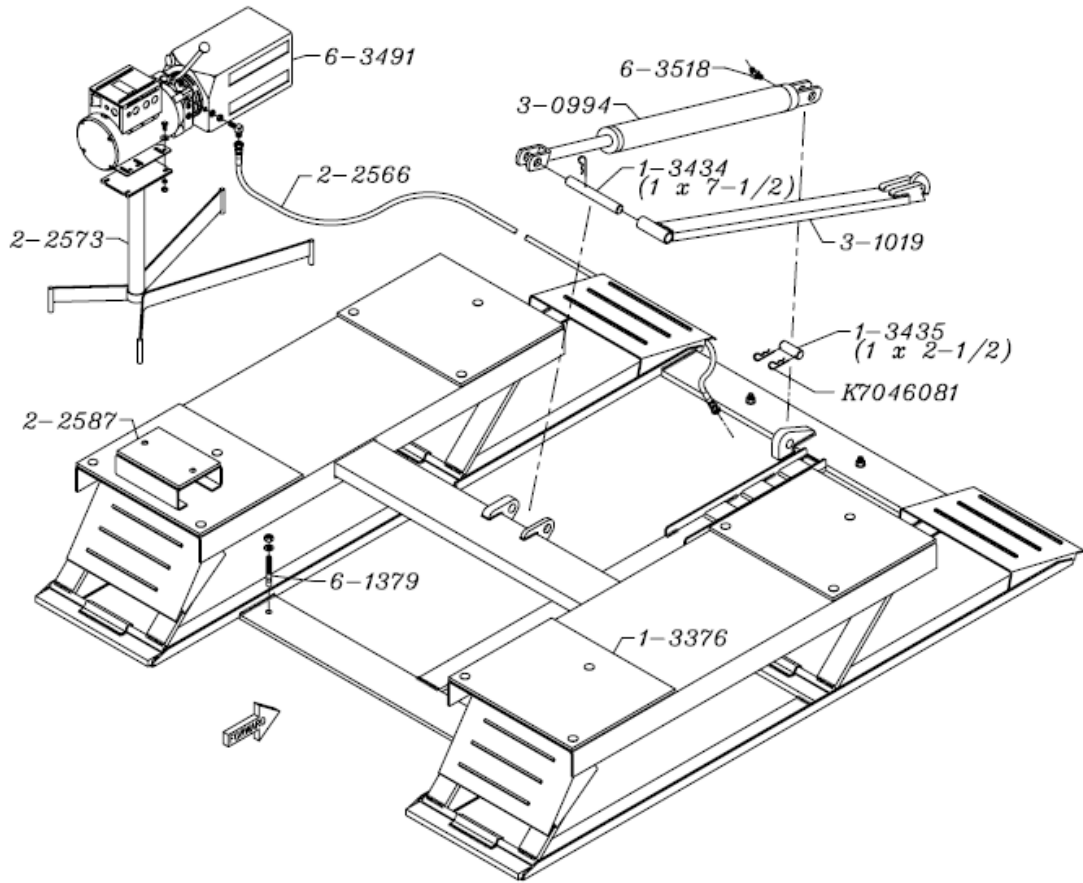

## 12.1 LIFT PARTS LIST

Part No.	QTY.	Description
3-0994	1	Hydraulic Cylinder
2-2587	4	3" Height Adapter Assembly
3-1019	1	Lock Leg Assembly
6-3491	1	Pumping Unit
2-2566	1	11' High Pressure Hose
2-2573	1	Pump Stand Assembly
6-3518	1	Cylinder Fitting
6-1379	4	Anchor Bolt
1-3435	1	1" x 2-1/2" Bottom Frame Axle
1-3434	1	1" x 7-1/2" Top Frame Axle
1-3376	4	15" x 18" Rubber Pad
K7046081	2	Cotter Pin 3/16" X 1-1/2" PLTD



# 13.0 POWER PACK ASSEMBLY

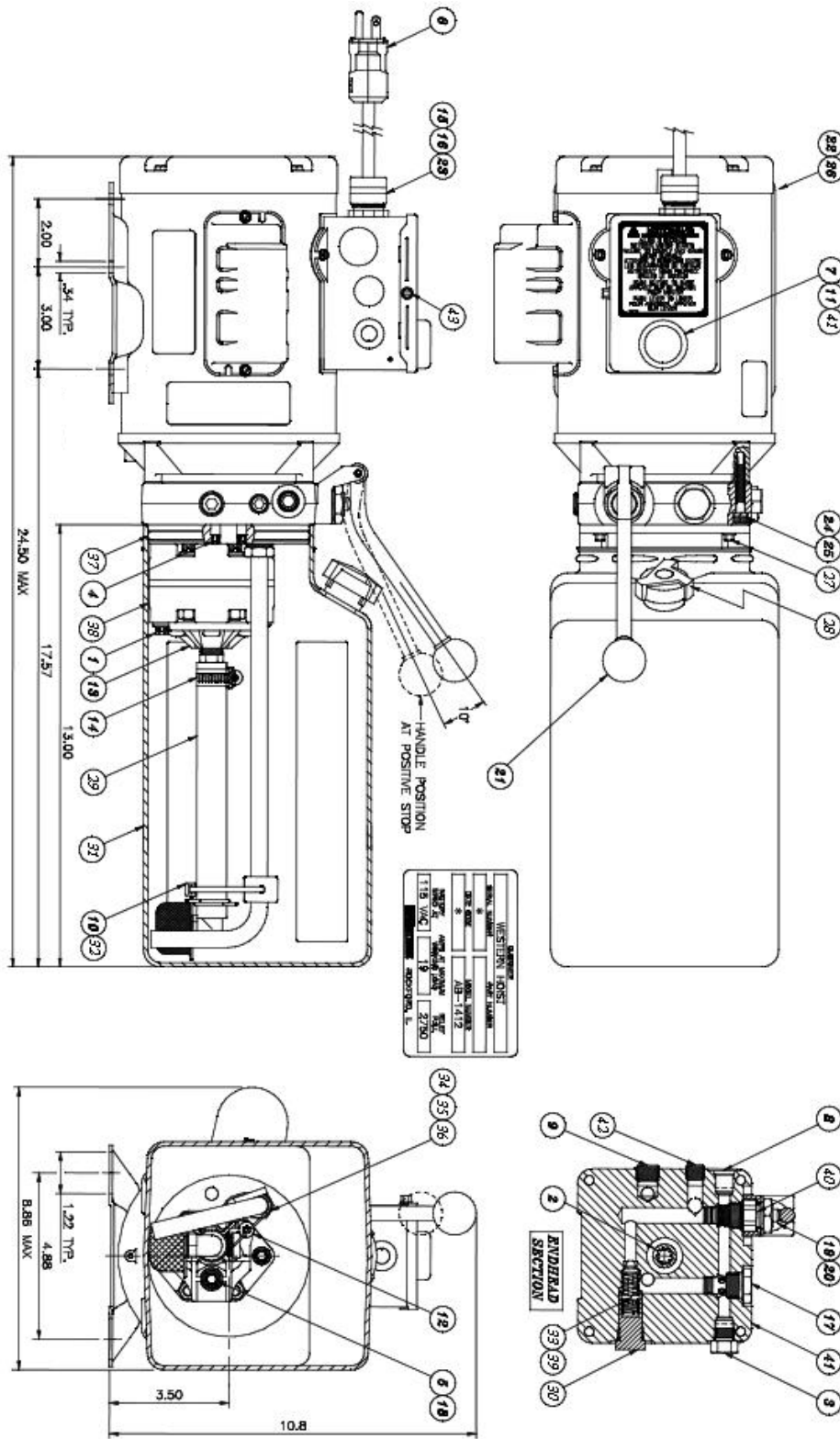

## 13.1 POWER PACK PARTS LIST

Assembly No.	Part No.	Description
1	6-2298	BOLT, 5/16" - 24" X 2-3/4" LG
2	6-0774	COUPLING (4 POST POWER PACK)
3	6-2157	PLUMBING PLUG 5/16" SAE
4	6-2158	SEAL SHAFT 0.5X1X.25
5	6-2159	WASHER .338X.625X.06
6	62300	CORDSET 16/3 SJO 8FT 115V PLUG
7	6-2156	WIRING ASSEMBLY AC 1PH FENNER
8	6-2301	PACKAGE PLUG 9/16" SAE
9	6-2157	PLUMBING PLUG 9/16 SAE
10	6-2162	PLUMBING MAGNET
11	6-2302	ELECTRICAL STAKON NUT
12	6-2164	SCREW TAPTITE TORX
13	6-2165	COVER ASY SUCTION
14	6-2166	CLAMPHOSESEADJ. INLET
15	6-2303	ELECTRIC CORD GRIP 3/4"NPT
16	6-2304	ELECTRIC PIPENUT 3/4"
17	6-1087	VALVE CARTRIDGE CHECK
18	6-2305	VALVE LOAD DELAY
19	6-2167	NUT 3/4"-16x1" HEX .25
20	6-2168	WASHER 3/4" INT TOOTH
21	6-1108	RELEASE HANDLE ASS'Y
22	6-3782	END HEAD UNIV.
23	6-2311	ELECT. REDUCER WASHER
24	6-2169	SHCS, M6X1 .35MM
25	6-2170	WASHER 1/4 LC HI-COLLR
26	6-2600	MOTOR(2781-BC)115/230V,1PH,1HP
27	6-1091	RESERVOIR SCREW
28	6-1376	BREATHER FILLER
29	6-0884	INLET HOSE/FILTER ASS'Y
30	6-1089	RELIEF VALVE CAP
31	6-3783	TANK 2.0 GAL WHITE
32	6-1846	CABLE TIE 8" LONG WHITE
33	6-1319	RV19
34	6-2153	COMPRESSION TUBE NUT
35	6-2154	COMP. TUBE SLEEVE
36	6-3786	RETURN TUBE 1/2 OD 90 DEG
37	6-0875	RESERVOIR O-RING
38	6-2306	PUMP ASS'Y 0.8 SHORT SPLINE
39	6-2151	SPRING .48X.063X.42
40	6-0880	VALVE CARTRIGE RELEASE MANUAL
41	6-2156	MICROSWITCH W/SNAP LID W-200
42	6-2161	PLUMB. PLUG 3/8NPT

43	6-3466	GROUNDING SCREW, #8-32 X 1/2"
----	--------	-------------------------------

**14.0 AVAILABLE ACCESSORIES**



**Figure 4 - Square Rubber Pad, Part No. 6-2776 (Set of 4)**