

HOFMANN



INSTALLATION and OPERATION MANUAL



MID RISE

MODEL

MRA6040 / MRE6040

6,000 LB. CAPACITY

**READ and SAVE THIS
INSTRUCTION MANUAL**

HOFMANN

USA



HOFMANN

CANADA



P.O. Box 600 • LaVergne, Tennessee 37086
(800) 251-4500 • (615) 641-1950
FAX (615) 641-3969
Internet: <http://www.hofmann-usa.com>

P.O. Box 1270 • Belleville, Ontario K8N 5E9
(613) 962-9138 • FAX (613) 962-8302
Internet: <http://www.hofmann.ca>
E-mail: hofmann.ca@sympatico.ca

AUGUST 2005

6-2291

TABLE OF CONTENTS	PAGE
1. GENERAL SPECIFICATION	2
2. TOOLS REQUIRED	2
3. SHIPPING CONTENTS	2
4. INSTALLATION INSTRUCTIONS	3
4.1 Unpacking Procedure	
4.2 Assembly Instructions	
4.3 Hydraulic System Installation	
4.4 Hydraulic System Bleeding Procedure	
5. POSITIONING INSTRUCTIONS	4
6. OPERATING INSTRUCTION	5
7. SAFETY INSTRUCTIONS	6
8. MAINTENANCE INSTRUCTIONS	7
8.1 Daily Maintenance	
8.2 Monthly Maintenance	
9. SAFETY AWARENESS	8
10. PARTS MANUAL	9
a. Mid-Rise Main Frame Assembly	10
b. Mid-Rise Main Frame Assembly - Part List	11
c. Hydraulic Cylinder Assembly	12
d. Hydraulic Cylinder - Part List	13
e. Power Pack Tow Cart	14
f. Power Pack Tow Cart - Part List	15
g. Power Pack	16
h. Power Pack - Part List	16
i. Pump Assembly	17
j. Pump Assembly – Part List	17
i. Power Pack Tow Cart Air	18
j. Power Pack Tow Cart Air - Part List	19

1. GENERAL SPECIFICATIONS

Maximum Capacity:

Maximum Lift Height:

Down Position Height:

Shipping Weight:

Lift Time 1. Electric Power Pack

2. Air Hydraulic Power Pack

Electric 115 V 1 H.P. Motor, 1 PH

Air Motor, 100 P.S.I

Unique Automatic Mechanical Safety Hydraulic Velocity Fuse

6,000 lbs.	2720 kg.
39.5"	1000mm
5"	127mm
950 lbs.	430 kg.
30 seconds	

2. TOOLS REQUIRED

7/16" wrench

5/16" wrench

5/8" wrench

Side cutters

3. SHIPPING CONTENTS

The complete Mid-Rise Lift series is contained in two (2) packages. The main structure is packaged onto a shipping skid. The main structure comes fully assembled with lifting arms, main rollers and hydraulics. The remaining items come in an accessory box.

Accessory Box Items:

1 Power Pack Tow Cart (with power pack and wheels)

1 "T" Handle

4 Rubber Lift Blocks

2 Truck Adapters (Optional)

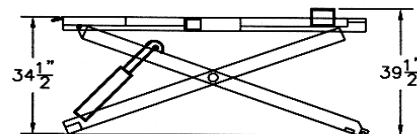
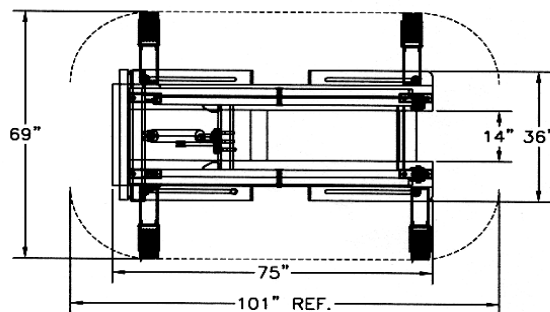

4. INSTALLATION INSTRUCTIONS

When lift arrives on site, please read the owner's manual and check for any freight damages. Also, check the contents to make sure no parts are missing before starting assembly.

4.1 UNPACKING PROCEDURE

Remove the metal strapping from the main structure package and slide the lift off the shipping skid. Open the accessory box and check the contents of the box.

NOTE: The Power Pack is already installed on the Tow Cart

4.2 ASSEMBLY INSTRUCTIONS

Install the handle onto the Power Pack Tow Cart. Align the hole and fasten together using the 1/4"-20UNC x 3/4" LG. hex head bolt and washer supplied.

4.3 HYDRAULIC SYSTEM INSTALLATION

1. Remove filler breather cap.
2. Add 3 liters of ISO 32 (10 Hydraulic weight) hydraulic oil to the Power Pack.
3. Add oil until it reaches the bottom of the filler neck.
4. Reinstall the filler breather cap onto the Power Pack.
5. Connect the 3/8" NPT-M end of the 12ft. long hydraulic hose to the 3/8" 90 degree fitting that is already installed on the short hydraulic hose at the front of the lift.
6. Install the 1/4" JIC female swivel end of the 12' long hydraulic hose to the outlet fitting on the power pack.
7. Plug the power pack utility cord into an approved 110V outlet.

4.4 HYDRAULIC SYSTEM BLEEDING PROCEDURE

NOTE: Make certain lift area is clear from debris and any obstructions.

1. Press the "UP" button on the power pack and raise the lift a few inches off the floor. Check for any hydraulic leaks.
Lower the lift by pushing on the down control lever on the power pack.
2. Lower completely.
3. Repeat this procedure.
4. Raise the lift to engage the mechanical safety lock.
5. Lower onto safety.
6. Raise the lift up a few inches and the mechanical safety will automatically disengage.
7. Lower lift completely.
8. Cycle the lift up and down completely a few times.
9. The hydraulic system is a self bleeding system.

5. POSITIONING INSTRUCTIONS

NOTE: Please review ALI safety card attached to tow cart and inspect lift for mechanical fitness before using.

NOTE: Lifts must only be installed on “level” concrete floors, with a minimum thickness of five (5) inches. Concrete must have a minimum strength of 4,000 psi, and should be aged 30 days prior to installation and use of the lift in this area.

1. To move, insert the lifting tab of the Power Tow Cart to the lifting bracket on the Mid-Rise. Tilt the cart back and move the Mid-Rise into position in the center of the work area or bay.
2. Remove the Power Tow Cart from the lifting bracket of the Mid-Rise and roll the cart to the front of the bay.
3. Plug the electric utility cord into an approved 110V outlet or an air line to the optional Air Motor.
4. With the lifting arms in the stowed position, in line with the main frame, drive a vehicle over the lift.

NOTE: When positioning a vehicle over the lift take time to equalize the load front-to-rear and side-to-side.

NOTE: The Mid-Rise lift may be used as a frame contact lift or as a platform lift, depending on the type of vehicle being worked on and the manufacturer recommended lifting points for that vehicle.

NOTE: Obstructions hanging down from the vehicle may be damaged when lifting. Always check between the vehicle and the contact points on the lift.

5. When in use as a frame contact lift, slide the lifting arms freely along the length of the arm support to the desired position. The flip up lift pads have three (3) positions, select and position as recommended to contact the correct lifting points for this vehicle.

NOTE: Some pickup trucks may require an optional riser adapter to clear running boards or other accessories.

When in use as a platform lift, move the lifting arms into the stowed position, in line with the main frame. Position the four (4) rubber lifting blocks on top ramp of the Mid-Rise.

6. OPERATING INSTRUCTIONS

1. Raise the lift by pressing the “UP” button on the front face of the Power Pack Motor.
2. Continue raising the lift until the mechanical safety “CLICKS” into position. Always lower the lift in order to fully engage the mechanical safety lock.

NOTE: All Mid-Rise lifts are equipped with dual safety locking devices, one (1) automatic mechanical safety bar, and second, a hydraulic velocity fuse to protect against hydraulic failure.

3. To disengage the safety and lower the lift, first press the “UP” button on the Power Pack Motor to raise the lift off of the mechanical safety. Continue to raise until automatic mechanical safety release device trips.
4. Lower the lift to the fully down position.
5. Reposition the lifting arms to the stowed position and/or remove the rubber lift blocks.
6. Drive the vehicle straight back off the lift.
7. If the Mid-Rise lift will not be used for any given period of time unplug the power cord.

7. SAFETY INSTRUCTIONS



DANGER: If the lift should become stuck at any raised position, do not attempt to lower the lift by loosening any hydraulic fittings. Contact technical services at 1-800-268-7959.

1. CAUTION

The Midrise lift is designed for tire, brake and body work. It is not recommended for under vehicle work. If this type of work is being done, use (4) adequate capacity & height safety stands at (4) appropriate lifting point on the vehicle. Safety stands are available from your lift dealer.

2. Inspect your Mid-Rise lift daily. Do not operate if it malfunctions or has damaged parts.

3. Never attempt to overload the lift. The manufacturer's rated capacity is shown on the serial number tag.
4. Operating controls, **DO NOT OVERRIDE** the automatic safety devices incorporated into the Mid-Rise lift. Press the "UP" button on the front face of the power pack motor to go up. Work on vehicle when the mechanical safety lock on the lift is activated.. To lower, raise the lift up until the automatic safety release device trips, then press down on the control lever.
5. Only trained and authorized personnel should operate the lift. Do not allow customers or bystanders to operate the lift or be in the work area.
6. Position the lifting arms of rubber lift blocks to contact the vehicle manufacturer's recommended lifting points. Raise the lift until the pads contact the vehicle. Check pads for secure contact with the vehicle, then raise the lift to the mechanical safety working height.
7. Always keep the lift area free of obstruction and debris. Grease and oil spills should be cleaned up immediately.

NOTE: When positioning a vehicle over the lift, take time to center the load front-to-rear and side-to-side. The removal or installation of some vehicle parts may cause a critical shift in the center of gravity and may cause the vehicle to become unstable.

8. Before driving on or off the lift make certain that the lift is completely in the down position, the lifting arms are in the stowed position and that the lifting pads are in the down position.

NOTE: DO NOT ATTEMPT TO OPERATE THE LIFT IF ANY PART IS NOT WORKING PROPERLY OR IF YOU HAVE NOT READ THE COMPLETE OPERATING INSTRUCTION MANUAL.

8. RECOMMENDED MAINTENANCE MID-RISE

8.1 DAILY MAINTENANCE

1. Check general operation of lift.
2. Check operation of automatic mechanical safety lock engaging and disengaging.
3. Check condition of floor in roller area for cracks and debris.
4. Check position of hydraulic hose, ensure that a vehicle positioned on the lift or the lift itself will not damage the hose.
5. Check condition of electrical cord before plugging into an approved 110V power supply.

8.2 MONTHLY MAINTENANCE





1. Check all hydraulic hoses, fittings and cylinder for leaks.
2. Check level of oil in power pack reservoir when hoist is in the lowered position. Add more if required.
3. Check and grease all hinge points.
4. Check and lubricate automatic safety release device.
5. Inspect 110V plug end and cable.
6. Inspect rollers on tow cart and main structure.
7. Inspect lift area for debris and concrete condition.

9. SAFETY AWARENESS - AUTOMOTIVE LIFT INSTITUTE (ALI)

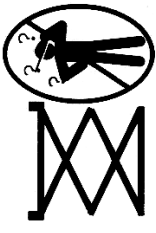
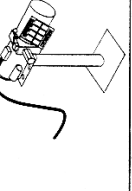
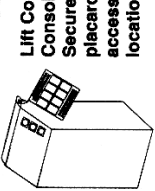
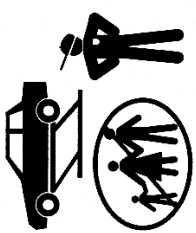
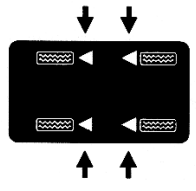
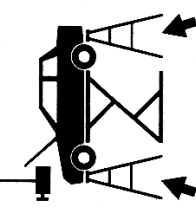
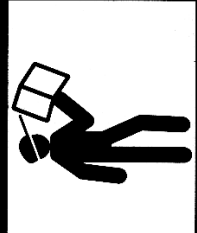
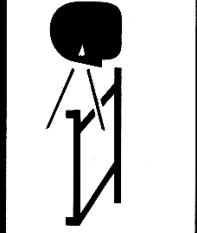
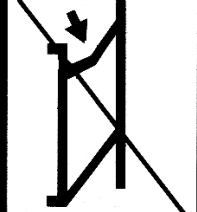
SAFETY WARNING LABELS FOR HINGED FRAME ENGAGING LIFTS
Lift Owner/User Responsibilities:

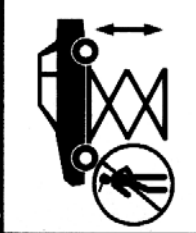
- A. This Safety Warning placard **SHALL** be displayed in a conspicuous location in the lift area.
- B. Use one of the mounting arrangements illustrated on back of this placard.
- C. These Safety Warning labels supplement other documents supplied with the lift.
- D. Be certain all lift operators read and understand these labels, operating instructions and other safety related information supplied with the lift.

<p>CAUTION</p>  <p>Lift to be used by trained operator only.</p>	<p>Power Unit: Secure placard near lift controls.</p>  <p>Lift Control Console: Secure placard in an accessible location.</p> 	<p>The messages and pictographs shown are generic in nature and are meant to generally represent hazards common to all automotive lifts regardless of specific style.</p> <p>Funding for the development and validation of these labels was provided by the Automotive Lift Institute, PO Box 33116 Indianatic, FL, 32903.</p> <p>They are protected by copyright. Set of labels may be obtained from ALI or its member companies.</p> <p>© 1992 by ALI, Inc. ALIWL 30024W</p>
<p>CAUTION</p>  <p>Authorized personnel only in lift area.</p>	<p>CAUTION</p>  <p>Use vehicle manufacturer's lift points.</p>	<p>CAUTION</p>  <p>Always use safety stands when removing or installing heavy components.</p>
<p>SAFETY INSTRUCTIONS</p>  <p>Read operating and safety manuals before using lift.</p>	<p>SAFETY INSTRUCTIONS</p>  <p>Proper maintenance and inspection is necessary for safe operation.</p>	<p>SAFETY INSTRUCTIONS</p>  <p>Do not operate a damaged lift.</p>

<p>WARNING</p>  <p>Position vehicle with center of gravity midway between adapters.</p>	<p>WARNING</p>  <p>Remain clear of lift when raising or lowering vehicle.</p>	<p>WARNING</p>  <p>Keep feet clear of lift while lowering.</p>
<p>WARNING</p>  <p>Clear area if vehicle is in danger of falling.</p>	<p>WARNING</p>  <p>Avoid excessive rocking of vehicle while on lift.</p>	<p>WARNING</p>  <p>Keep clear of pinch points when lift is moving.</p>

MID-RISE MAIN FRAME ASSEMBLY

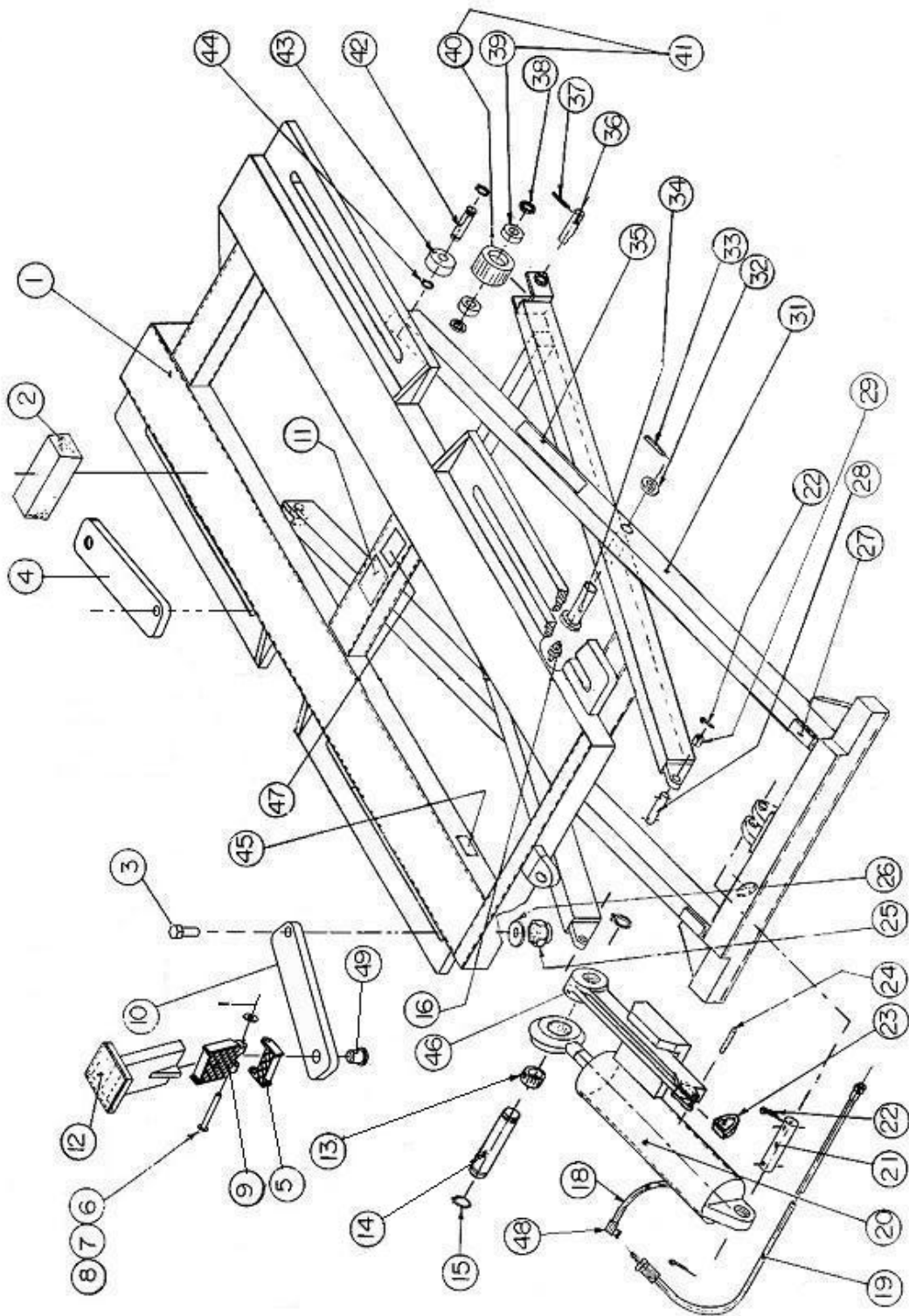

MID-RISE MAIN FRAME ASSEMBLY - PARTS LIST

ITEM NO.	QTY.	DESCRIPTION	PART NO.
1	1	TOP RAMP ASSEMBLY	4-0200
2	4	RUBBER BLOCK	6-1074
3	4	ARM BOLT	1-1076
4	2	ARM ASSEMBLY L.H.	2-1809
5	4	LOW ADAPTER	3-0583
6	4	CENTER PIN	1-1099
7	4	FLAT WASHER 1/2" I.D.	6-0063
8	4	COTTER PIN 1/8" X 1" LG.	6-0267
9	4	HIGH STEP ADAPTER	3-0582
10	2	ARM ASSEMBLY R.H.	2-1808
11	1	SERIAL PLATE	6-0763
12	2	TRUCK PAD ADAPTER (OPTIONAL)	2-1159
13	1	BUSHING	6-0976
14	1	SHAFT CYLINDER MOUNT	1-0814
15	2	CIRCLIP	6-0340
16	3	GREASE NIPPLE	6-0000
18	1	HYDRAULIC HOSE 19" LG.	1-0858
19	1	HYDRAULIC HOSE 12 FT LG.	2-0602
20	1	HYDRAULIC CYLINDER ASSEMBLY	4-0199
21	1	CYLINDER PIN	1-0861
22	6	COTTER PIN 1/8"-1 1/2" LG.	6-0978
23	1	OVERRIDE SAFETY CAM	2-0819
24	1	SPRING PIN 1/4" X 1 1/2" LG.	6-0745
25	4	UNI-TORQUE LOCK NUT 1"-8UNC	1-1385
26	4	FLAT WASHER 1" I.D.	6-1106
27	4	NEOPRENE STRIP	6-0993
28	2	HINGE PIN	1-0857
29	2	BUSHING	6-0795
31	1	SCISSOR ASSEMBLY	4-0203
32	2	KEEPER WASHER	1-0725
33	2	SPRING PIN 3/16" X 2" LG.	6-0146
34	2	SCISSOR PIN	1-0838
35	1	DECAL	6-0762
36	2	PIN	1-0837
37	2	SPRING PIN 3/16" X 1 1/4" LG.	6-0749
38	4	WASHER 7/8" I.D.	6-0725
39	4	BEARING	6-0751
40	2	ROLLER	1-0807
41	2	ROLLER ASSEMBLY KIT	0-0191
42	2	TRACK ROLLER SHAFT	1-0823
43	2	TRACK ROLLER (UPPER)	6-0750
44	4	CIRCLIP	6-0752
45	1	ALI PLATE	6-0398
46	1	SAFETY LOCK MECHANISM	3-0352
47	1	ETL/ALI STICKER	6-0996
48	1	3/8" NPT-F 90 DEGREE HYDRAULIC STEEL FITTING	6-0006
49	4	ADAPTER PIN	1-1091

HYDRAULIC CYLINDER ASSEMBLY

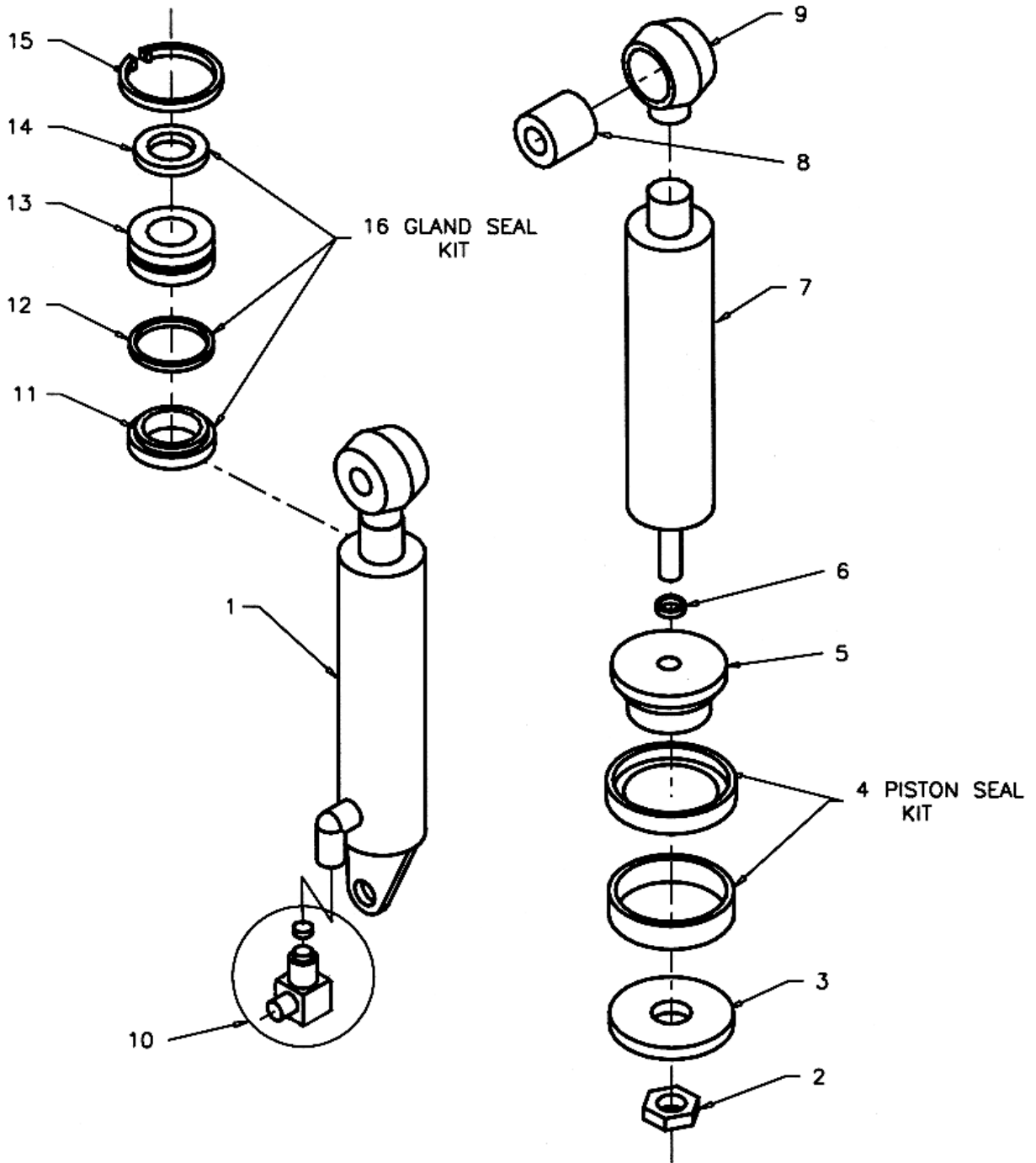

HYDRAULIC CYLINDER ASSEMBLY - PARTS LIST

ITEM NO.	QTY.	DESCRIPTION	PART NO.
1	1	CYLINDER TUBE WELDMENT	3-0350
2	1	7/8"-9UNC HEX LOCKNUT	6-0631
3	1	WASHER, 7/8" I.D.	1-0809
4	1	PISTON SEAL KIT	0-0181
5	1	PISTON	2-0586
6	1	"O" RING	6-0656
7	1	PISTON ROD	2-0832
8	1	BEARING	6-0976
9	1	ROD CLEVIS	2-0833
10	1	90° VELOCITY FUSE ASS'Y	1-1726
11	1	ROD SEAL	6-0754
12	1	"O" RING	6-0756
13	1	GLAND	2-0587
14	1	WIPER	6-0001
15	1	CIRCLIP	6-0755
16	1	GLAND SEAL KIT	0-0183

POWER PACK TOW CART

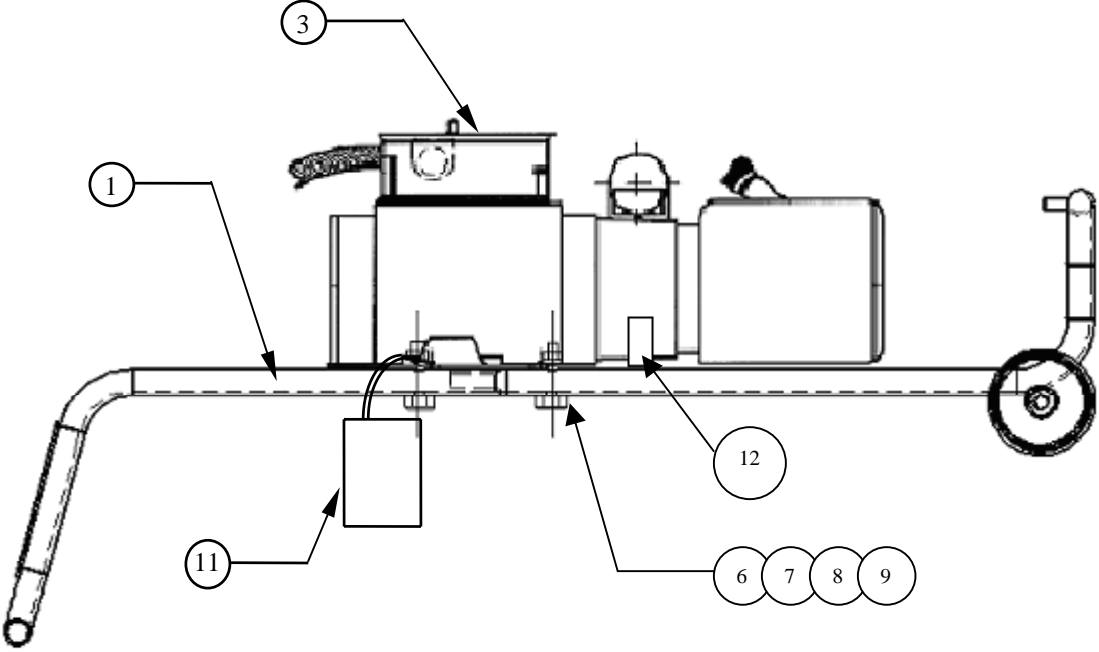
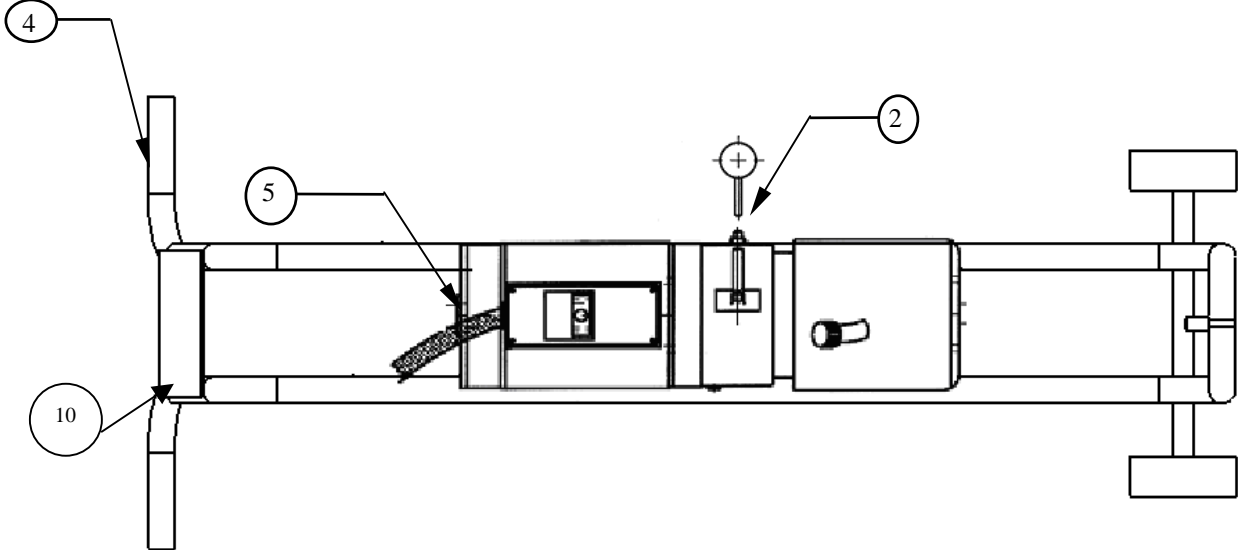

POWER PACK TOW CART - PARTS LIST

ITEM NO.	QTY.	DESCRIPTION	PART NO.
1	1	STAND (WITH WHEELS AND HUB CAP NUTS)	4-0207-01
2	1	ADAPTER-MACHINED W/ ORIFICES (.035" DIA)	1-1063
3	1	POWER PACK 115/230V 1PH 60HZ 1 HP	6-2249
4	2	GRIP HANDLE	6-0758
5	1	PLUG	6-1711
6	4	HEX BOLT 1/4"-20UNC	6-0028
7	4	LOCKWASHER 1/4" I.D.	6-0056
8	4	FLAT WASHER 5/16" I.D.	6-0295
9	4	HEX NUT 1/4"-20UNC	6-0032
10	1	DECAL "OPERATING INSTRUCTIONS"	6-0759
11	1	ALI PLACARD	6-0990
12	1	90° ELBOW	6-1093
*	1	COMPLETE TOWCART W/ ELECTRIC POWER PACK	4-0206

-SEE NEXT PAGE FOR THE POWER PACK ASSEMBLY

POWER PACK: #6-2249 (AB-1425) 115-230V/1PH/60Hz

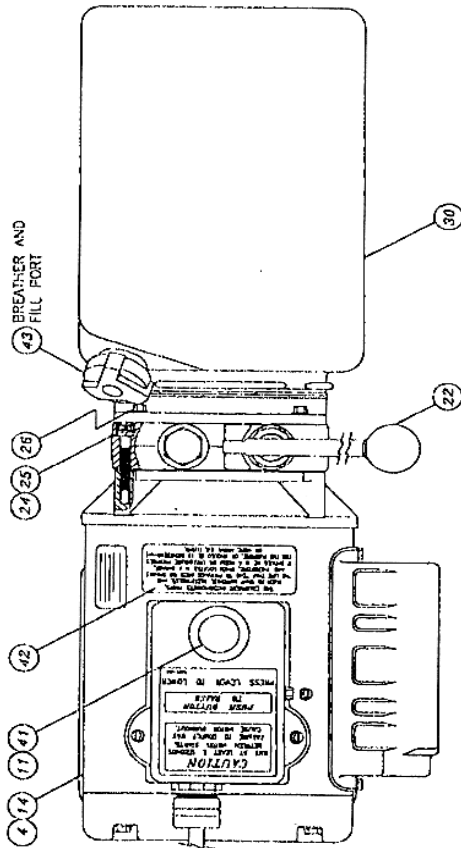
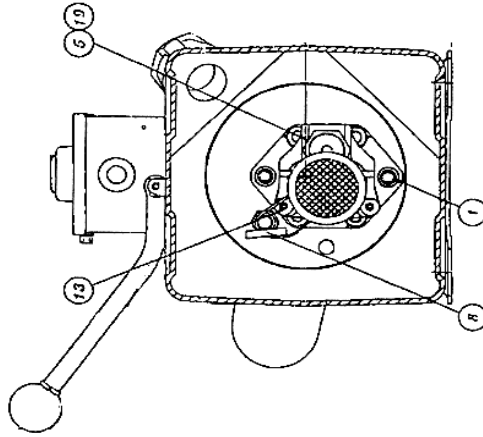
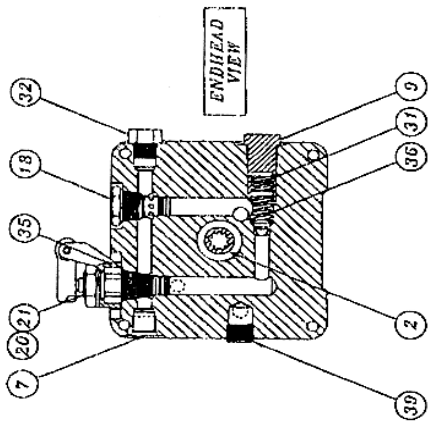

LUBRICANT	
WHEELER	WHEELER
SPECIAL SERVICE	SPECIAL SERVICE
BILL CODE	BILL CODE
AB-1425	AB-1425
FACTORY	FACTORY
115 VAC	15
AMPS at maximum	RELAY
3500	3500
Turner Fluid Power Inc., Rockford, IL	

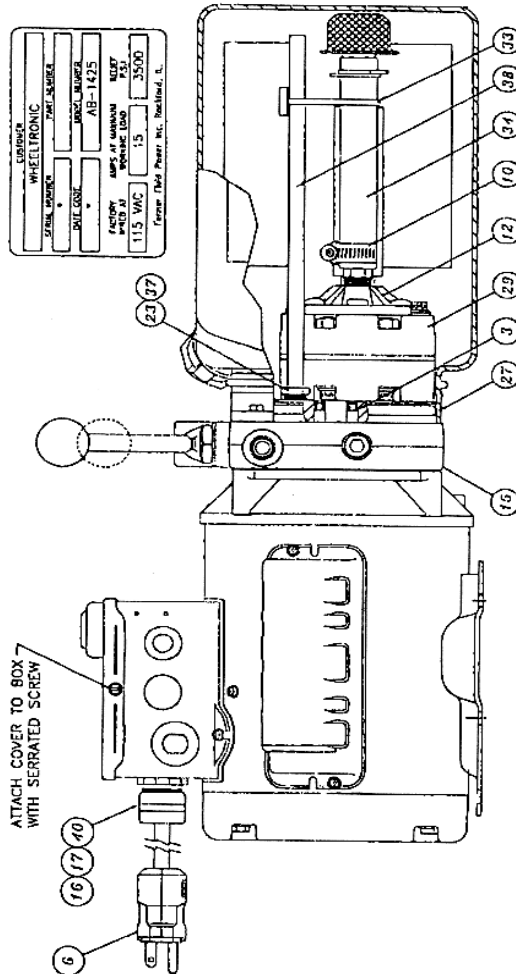

POWER PACK PARTS LIST: #6-2249 (AB-1425) 115-230V/1PH/60Hz

ITEM	QTY.	DESCRIPTION	PART #
1	2	BOLT 5/16"-24 x 2 3/4" TORX G8	6-2298
2	1	COUPLING SAE 9T-20/40 1.260"	6-0774
3	1	SEAL SHAFT 0.500" x 1.00" x 0.25"	6-2158
4	1	MOTOR AC PSC #613000 115/230 1 HP 1PH BLK	6-2299
5	1	WASHER 0.338" x 0.625" x 0.060" STEEL	6-2159
6	1	CORDSET 16/3 SJO 8FT 115V PLUG	6-2300
7	1	PACKAGE PLUG 9/16" SAE	6-2301
8	1	PLUMBING MAGNET	6-2162
9	1	RELIEF VALVE CAP ASSEMBLY	6-1089
10	1	PLUMBING CLAMP HOSE ADJ INLET	6-2166
11	2	ELECTRIC STAKE-ON NUT	6-2302
12	1	COVER ASS'Y SUCTION	6-2165
13	2	SCREW TAPTITE M6x1.0 12MM TORX	6-2164
14	1	NAMEPLATE, SERIAL	
15	1	ENDHEAD UNIVERSAL AUTOHOIST	6-2155
16	1	ELECTRIC CORD GRIP 3/4" NPT	6-2303
17	1	ELECTRIC PIPENUT 3/4"	6-2304
18	1	VALVE CARTRIDGE CHECK	6-1087
19	1	VALVE LOAD DELAY	6-2305
20	1	NUT 3/4"-16 x 1" HEX x 0.250 STEEL	6-2167
21	1	WASHER 3/4" INT. TOOTH LOCK	6-2168
22	1	BRACKET HANDLE ASS'Y REL BLACK	6-0776
23	1	COMPRESSION TUBE NUT	6-2153
24	4	BOLT M6 x 1.0 35MM SOC HD	6-2169
25	4	WASHER 1/4" LOCK HI-COLLAR	6-2170
26	4	BOLT #12-24 x .50 HEX WSHRHD	6-1091
27	1	O-RING 2-348 BUNA	6-0875
28	1	COVER ASSY SUCTION	6-2165
29	1	PUMP ASS'Y 0.8 SHORT SPLINE	6-2306
30	1	TANK PLASTIC 6.7 CT 11.0" BLACK	6-2307
31	1	SPRING 0.480" x 0.063" x 0.42" COMP	6-2151
32	1	PLUMBING PLUG 5/16" SAE	6-2157
33	1	CABLE TIE 8" LONG WHITE	6-1846
34	1	PLUMBING ASS'Y INLET 6.61 (3)	6-2308
35	1	VALVE CARTRIDGE RELEASE MANUAL	6-0880
36	1	RELIEF ASSEMBLY FIXED 260 BAR	6-1326
37	1	COMPRESSION TUBE SLEEVE	6-2154
38	1	RETURN HOSE 3/8" OD x 10.0"	6-2310
39	1	PLUMBING PLUG 3/8"NPT	6-2161
40	2	ELECTRIC REDUCER WASHER	6-2311
41	1	WIRING ASSEMBLY AC 1PH FENNER	6-2156
42	1	LABEL INSTALLATION AUTOHOIST	6-2136
43	1	BREATHER CAP & BLADDER	6-1376

AIR POWER PACK

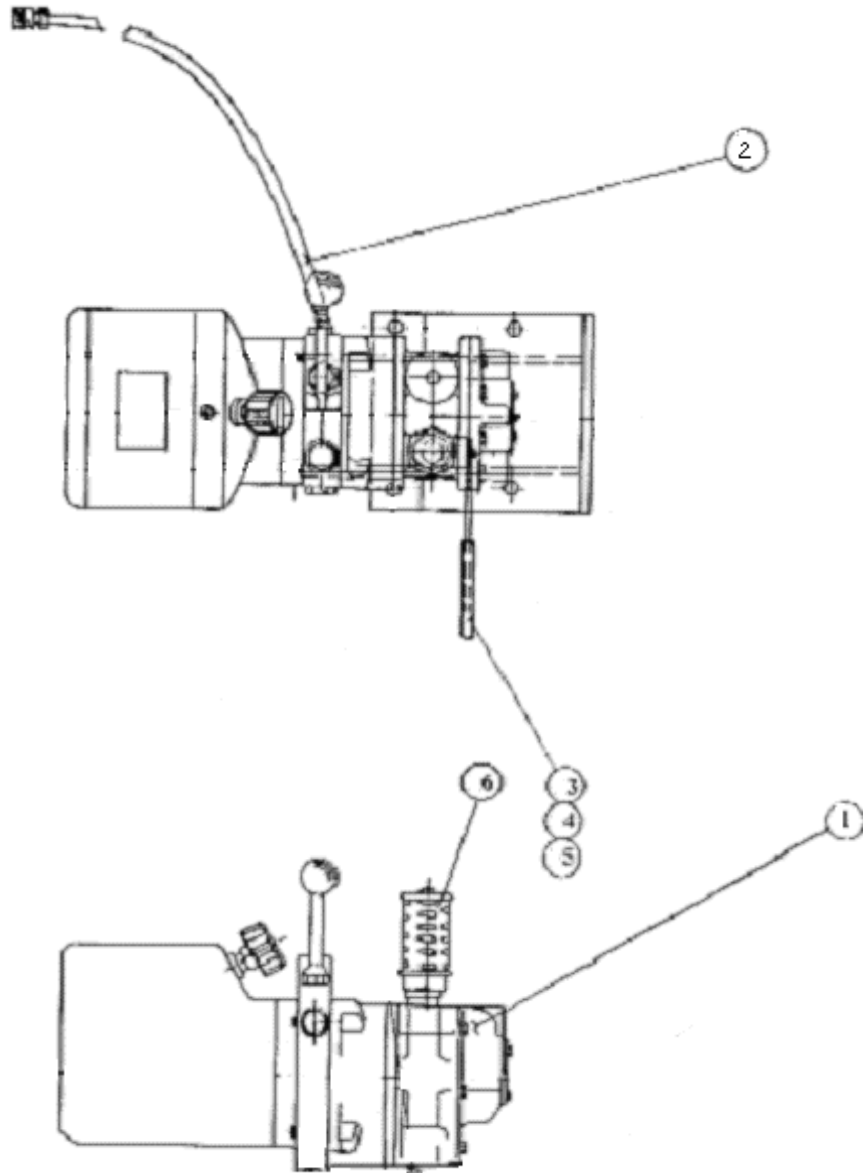

AIR POWER PACK - PARTS LIST

ITEM NO.	QTY.	DESCRIPTION	PART NO.
1	1	AIR HYDRAULIC PUMP "AC-10TC UTILIZING VA-4S VANE AIR MOTOR"	6-0919
2	1	HYDRAULIC HOSE - 12FT.	2-0602
3	1	BALL VALVE	6-0940
4	1	3/8" STEEL NIPPLE	6-0953
5	1	REDUCER 3/4" M PIPE/ 3/8" F PIPE	6-0285
6	1	EXHAUST MUFFLER	6-0958
*	1	COMPLETE TOWCART W/ AIR POWER PACK	4-0274