

SUN®

INSTALLATION and OPERATION MANUAL

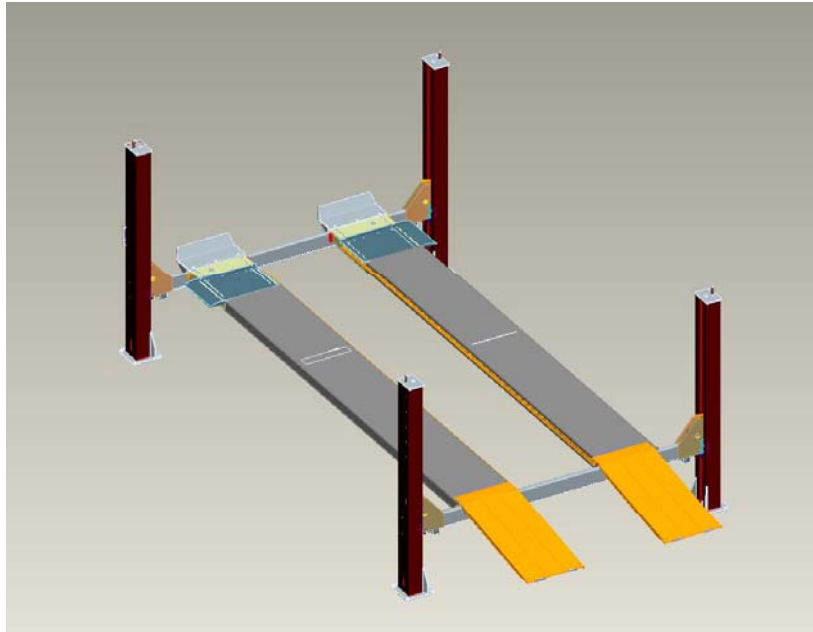

4 POST

(Model # EELR102A/
EELR103A)

12,000 LB.

**READ THIS INSTRUCTION MANUAL THOROUGHLY BEFORE
INSTALLING, OPERATING, SERVICING OR MAINTAINING THE
LIFT. SAVE THIS MANUAL.**

SUN®

1-800-268-7959

JUN 10 REV A

6-1793

THE FOLLOWING APPLIES TO LIFTS

IMPORTANT SAFETY INSTRUCTIONS

1. When using this lift, basic safety precautions should always be followed, including the following:
2. Read all instructions in this manual and on the lift thoroughly before installing, operating, servicing or maintaining the lift.
3. Inspect lift daily. Do not operate if it malfunctions or problems have been encountered.
4. Never attempt to overload the lift. The manufacturer's rated capacity is shown on the identification label on the power side column. Do not override the operating controls or the warranty will be void.
5. Only trained and authorized personnel should operate the lift. Do not allow customers or bystanders to operate the lift or be in the lift area.
6. **Caution! Never work under the lift unless the mechanical safety locks are engaged.**
7. Always keep the lift area free of obstruction and debris. Grease and oil spills should always be cleaned up immediately.
8. Never raise vehicle with passengers inside.
9. Before lowering check area for any obstructions
10. To protect against the risk of fire, do not operate lift in the vicinity of open containers of flammable liquids.
11. Adequate ventilation should be provided when working on internal combustion engines.
12. Do not remove hydraulic fittings while under pressure.
13. Do not raise or lower the lift with the vehicle on the Jack Beam.

SAVE THESE INSTRUCTIONS

+ 070126-Quadra-WLSIA01

SAFETY INSTRUCTIONS

If attachments, accessories or configuration modifying components that are located in the

load path, affect operation of the lift, affect the lift electrical listing or affect intended vehicle accommodation are used on this lift and, if they are not certified for use on this lift, then the certification of this lift shall become null and void. Contact the participant for information pertaining to certified attachments, accessories or configuration modifying components.

www.autolift.org

©2007 by ALI, Inc.

ALI / WLSIA01

TABLE OF CONTENTS

1.0	SPECIFICATIONS	4
2.0	TOOLS REQUIRED FOR INSTALLATION.....	5
3.0	CONTENTS	6
4.0	INSTALLATION INSTRUCTIONS	7
4.1	Chalk Line Layout	9
4.2	Front And Rear Crossmember Assembly.....	10
4.3	Sheaves Installation	11
4.4	Cable Installation	12
4.5	Power Pack Installation.....	14
4.6	Electrical Connections	15
4.7	Hydraulic Installation.....	15
4.8	Air Installation	17
4.9	Safety Retaining System.....	18
4.10	Leveling Procedure - Cables	19
4.11	Anchor Installation	20
4.12	Leveling Procedure – Safety Ladders	21
4.13	Final Check Of Assembled Lift	23
4.14	Operation Test With Vehicle	24
5.0	SAFETY AND OPERATING INSTRUCTIONS	25
6.0	SAFETY AWARENESS	26
7.0	RECOMMENDED MAINTENANCE GUIDELINES.....	27
8.0	PARTS MANUAL	29
8.1	Lift Assembly.....	29
8.2	Lift Parts List	30
8.3	Hydraulic And Air Kits Assembly	33
8.4	Hydraulic And Air Kits Part List.....	34
8.5	Cable Routing Diagram.....	35
8.6	Cable Routing Parts List	36
8.7	Safety Retainer Bracket	37
8.8	Power Pack	38
8.9	Power Pack Parts List	39
9.0	AVAILABLE ACCESSORIES	41

1.0 SPECIFICATIONS

Maximum Capacity:
 Overall Length:
 Overall Width:
 Down Position Height:
 Maximum Lifting Height:
 Maximum Wheel Base:
 Power Rating:
 Air Requirements:
 Shipping Weight:
 Alignment / Service

12000 lbs.	5443 kg
266"	6756mm
137"	3480mm
9.5"	241mm
71"	1803mm
172"	4369mm
208-230 Volts AC, 1Ph., 20 Amp, 60Hz.	
90 – 120 psi Shop Air	
3885 lbs. / 3750 lbs.	1704 kg / 1765 kg

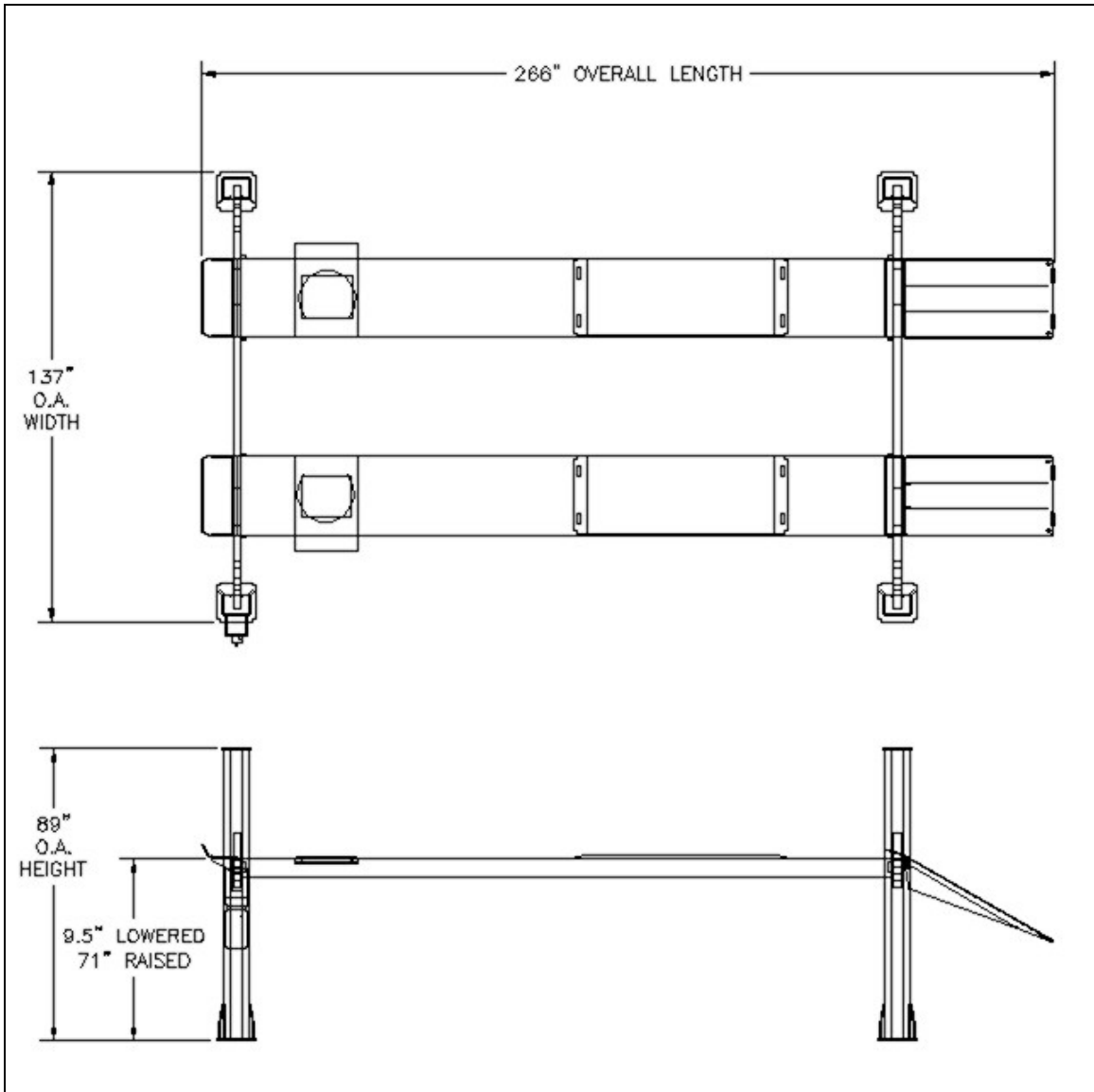

**CHECK CONTENTS OF ACCESSORY BOX WITH THE PACKING LIST
ENCLOSED**



ATTENTION! This lift is intended for indoor installation only. It is prohibited to install this product outdoors. Operating environment temperature range should be 41 – 104 °F (5 – 40 °C). Failure to adhere will result in decertification, loss of warranty, and possible damage to the equipment.

2.0 TOOLS REQUIRED FOR INSTALLATION

ROTARY HAMMER DRILL
3/4" CONCRETE DRILL BIT
SOCKET FOR TIGHTENING ANCHORS
4' LEVEL
HAMMER (for anchor installation)
PRY BAR (for shim installation)
CHALK LINE (lift location)
FISH (mechanics wire to feed cable through crossmember assembly)
TAPE MEASURE
ELECTRICAL TAPE
STEP LADDER (adjusting cables and/or safety ladder in posts)
SIDE CUTTERS (for cutting shipping straps)
BAR (4' long)
4 WORK STANDS (set up)
STANDARD SOCKETS AND WRENCHES
ENGINE CRANE

IMPORTANT: It is the user's responsibility to provide a satisfactory installation area for the lift. Lifts should only be installed on level concrete floors with a minimum thickness of five (5) inches or 130 mm. Concrete must have a minimum strength of 4000 psi or 30 MPa and should be aged thirty (30) days prior to installation. Please consult the architect, contractor or engineer if doubt exists as to the strength and feasibility of the floor to enable proper lift installation and operation.

It is the user's responsibility to provide all wiring for electrical hook-up prior to installation and to insure that the electrical installation conforms to local building codes. Where required, it is the user's responsibility to provide an electrical isolation switch located in close proximity to the lift that will enable emergency stop capability and isolate electrical power from the lift for any servicing requirements.

3.0 CONTENTS

The lift is packaged to protect from any damage that may occur in shipping. The two deck assemblies and crossmembers are packaged together with the accessory boxes strapped to them.

Main Structural Components:

- 1 - Left Side Deck Assembly (complete with hydraulic cylinder)
- 1 - Right Side Deck Assembly
- 1 - Front Crossmember Assembly (with air cylinder release locks and sheaves)
- 1 - Rear Crossmember Assembly (with air cylinder release locks and sheaves)

Accessory Box Components

Box 1 Contents:

- 1 - Power Post (with safety ladder)
- 3 - Post (with safety ladder)

Box 2 Contents:

- 1 - Power Pack Assembly complete with Flow Control
- 2 - Approach Ramps
- 7 - Sheave Assemblies
- 1 - Set of Cables (set contains 4 cables with nuts and spacers)
- 7 - Sheave Spacers (different sizes)
- 2 - Front Wheel Stops
- 2 - Ramp Pins
- 4 - Deck Sheave Pins
- 1 - Air Kit (with 1/4" and 3/8" polytube and fittings)
- 1 - Hydraulic Hose (with fittings)
- 1 - Hose Guard
- 4 - Sheave Covers
- 3 - Cable Tie (for attachment of hydraulic hose to cylinder)
- 2 - Recoiled Air Hoses 12' long
- 1 - Coupler 1/4" NPT
- 1 - Package of Hardware (with its own packaging list)
- 1 - Owner's manual
- 1 - ALI manual "Lifting It Right"
- 1 - Automotive Lift Safety Tips
- 1 - Automotive Lift, Operation, Inspection and Maintenance manual

4.0 INSTALLATION INSTRUCTIONS

PLEASE TAKE THE TIME TO READ THESE INSTRUCTIONS COMPLETELY. A QUICK CHECK OF THE CONTENTS OF THE ACCESSORY BOX WOULD ALSO DECREASE THE OVERALL TIME OF THE INSTALLATION.

- Gather the tools and materials required for the installation.
- Select the location best suited for your lift.

NOTE: In determining lift area check for the following:

- Ease of driving a vehicle on and off the lift.
- Overhead obstructions, low ceiling height, overhead doors, overhead heaters, etc.
- Floor obstructions, uneven floor in lift area, floor drains, work benches, electrical in floor, etc.

Recommended clearance around the lift is three (3) feet. Ensure clearance conforms to local building and fire codes.

Recommended overhead clearance is a minimum twelve (12) foot ceiling providing 6 feet for the maximum lift height and 6 feet for the supported vehicle. For vehicles taller than 6 feet it is recommended that the user provides additional overhead clearance or a shut off mechanism to stop the lift from raising the vehicle too high.

- An outline matching the dimensions listed below will need to be marked on the floor. Refer to Figure 1 General Lift Specifications for overall lift dimensions.

GENERAL LIFT SPECIFICATIONS

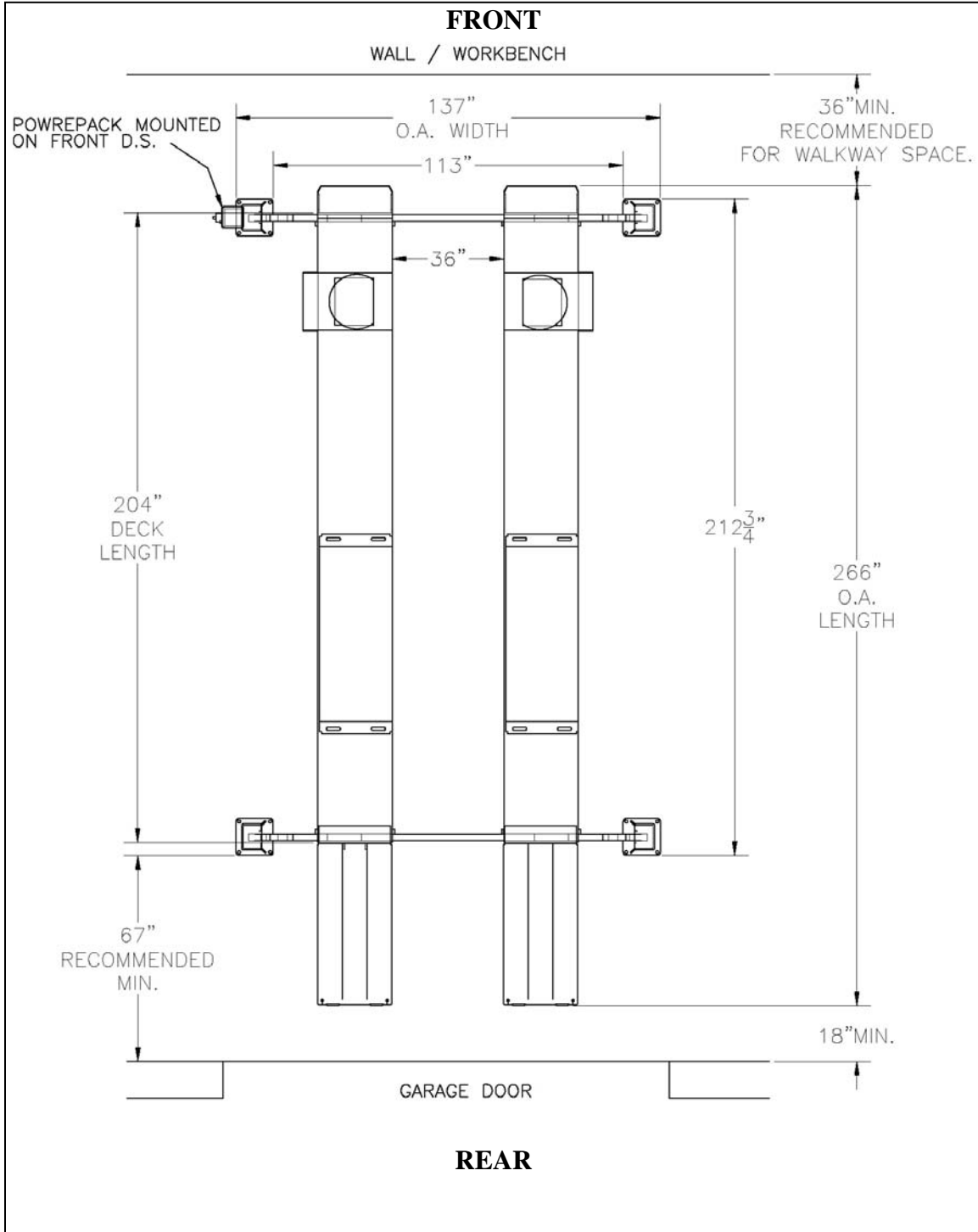

Figure 1. Plan view

4.1 CHALK LINE LAYOUT

Refer to

Figure 1. Make a chalk line parallel to the doorway at least 279³/₄" in from the doorway. This will be the furthest front face of the front post baseplate location. Call this line "A". Determine the center of the doorway and bay. Make a centerline to intersect with line "A". Measure from the centerline along line "A" 60¹/₂" in both directions. This will be the location of the inside face and front face of the front posts. Measure back from this line "A" 212³/₄". Make a chalk line parallel to line "A". Call this line "B". This will be the location for the back face of the rear post baseplates. Measure from the centerline along line "B" 60¹/₂" in both directions. This will be the location of the inside face and back face of the rear posts. Position work stands inside of line "A" and "B" of outline, to support the front and rear of each deck assembly.

IMPORTANT

- Position decks on work stands.

NOTE: To determine the front and rear crossmember assembly see Figure 2, and check the following:

- The front crossmember assembly will have two (2) small openings for the cable routing. The openings will face the rear of the lift.
- The rear crossmember assembly will have one (1) small opening and one (1) larger opening for cable routing. These openings will face the front of the lift.
- The crossmember assemblies are fully assembled and the PULLEYS DO NOT NEED TO BE REMOVED FOR CABLE INSTALLATION. ALIGN CROSS-MEMBER ASSEMBLIES SO THAT THE DIAGONALS MEASURE WITHIN HALF AN INCH SQUARE.
- Install the crossmember assemblies under the front and rear of each deck assembly. The decks will fit inside the locating tabs of the crossmember assemblies. Install eight (8) 1/2 - 13 UNC × 1" lg. set screws to hold the decks to the crossmember assemblies. One set screw to the front and rear of each deck and one set screw into the four outer locating tabs on the front and rear crossmember assemblies.
- Reposition work stands under front and rear crossmember assemblies.

4.2 FRONT AND REAR CROSSMEMBER ASSEMBLY

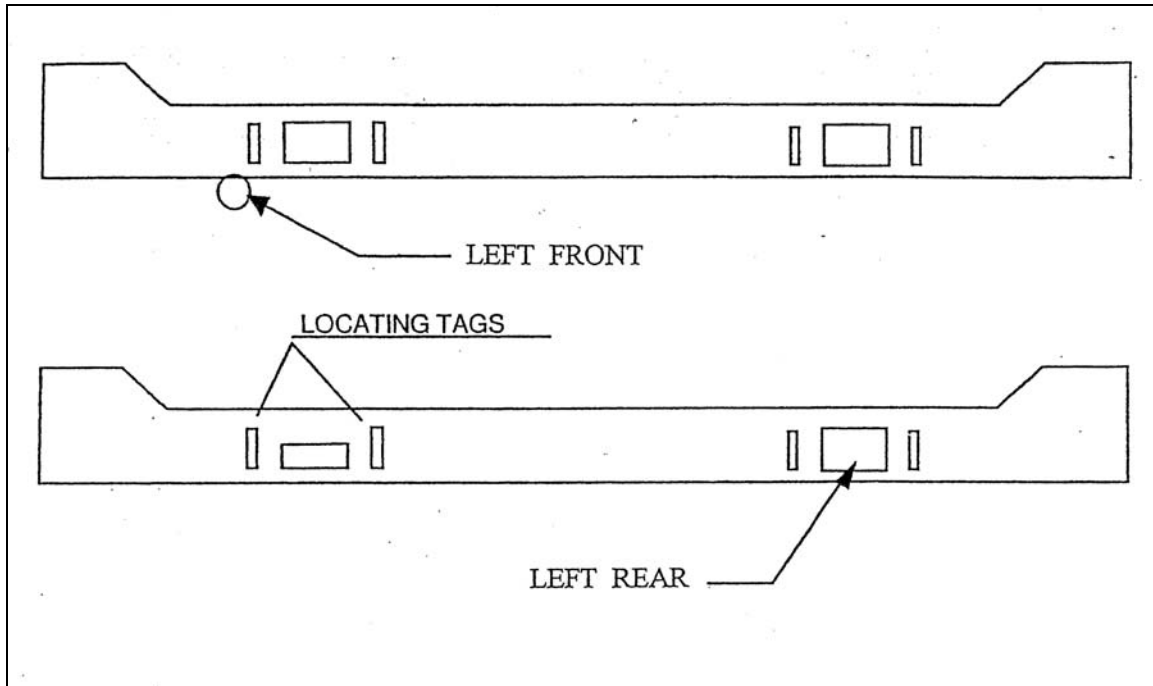

Figure 2. Front and rear crossmembers

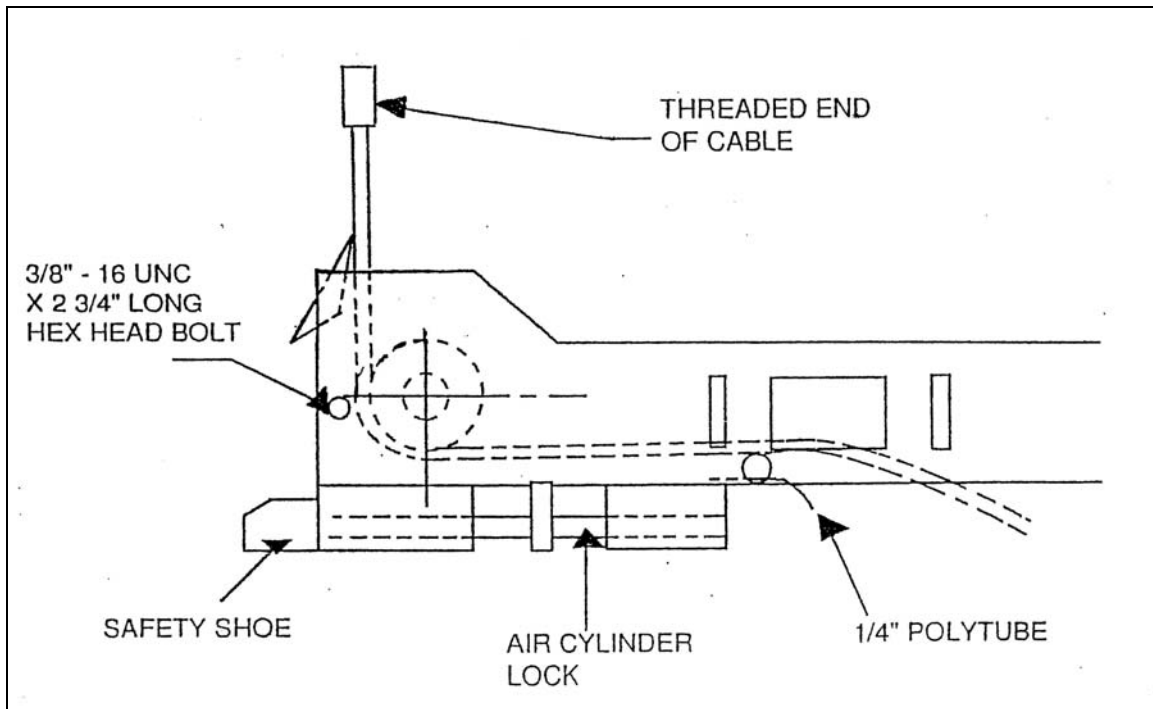

Figure 3. Typical cable routing in crossmember assembly

4.3 SHEAVES INSTALLATION

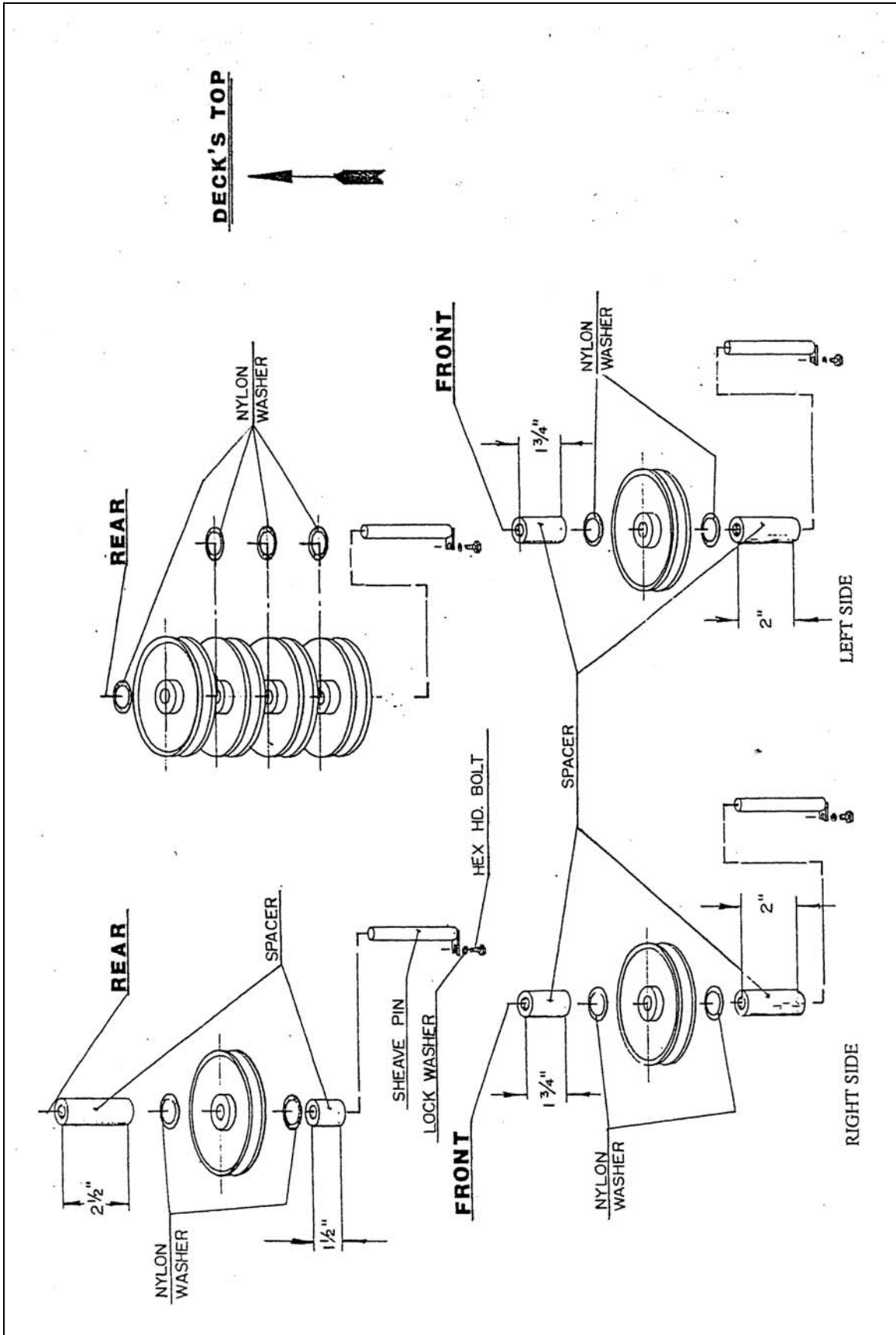

Figure 4. Sheaves installation

4.4 CABLE INSTALLATION

- Locate cables and set out on the floor. Check the part numbers located on each stud of each cable.

CABLE #1.....PART #2-0539 (376"LG. - L.F.)

CABLE #2.....PART #2-0540 (181"LG. - L.R.)

CABLE #3.....PART #2-0541 (233"LG. - R.R.)

CABLE #4.....PART #2-0542 (427"LG. - R.F.)

Refer to Section 8.5

NOTE: THE PULLEYS (SHEAVES) ON THE CROSSMEMBERS DO NOT HAVE TO BE REMOVED FOR CABLE INSTALLATION. A 3/8" - 16 UNC × 2 3/4" LG. HEX HEAD BOLT MUST BE REMOVED FROM THE CROSSMEMBERS TO ALLOW CABLE INSTALLATION AROUND THE PULLEYS. THIS 3/8" - 16 UNC × 2 3/4" LG. HEX HEAD BOLT MUST BE REINSTALLED AFTER THE CABLES ARE ROUTED THROUGH THE CROSSMEMBER ASSEMBLIES.

WARNING!!!

DO NOT APPLY LUBRICANT TO SHEAVE ASSEMBLY. FIBRE BUSHING IS PTFE SELF-LUBRICATING. THE ADDITION OF LUBRICANT WILL SHORTEN THE LIFE OF THE FIBRE BUSHING.

- Before beginning cable routing, refer to Figure 3 Cable and Routing Diagram.
- Begin routing cable #4 (part #2-0542) from the right side of the front crossmember assembly using the non threaded end of the cable as described in Figure 3 and section 8.5, and out through the opening under the front of the right deck.
- CHECK FOR CORRECT ARRANGEMENT OF SPACERS ON SHEAVE STACKS, FIGURE 4.
- Install the sheave into the front of the right deck as shown in Figure 4.

NOTE: MAKE CERTAIN THAT THE CABLE RUNS BETWEEN THE WELDED GUIDE PIN AND THE GROOVE IN THE PULLEY.

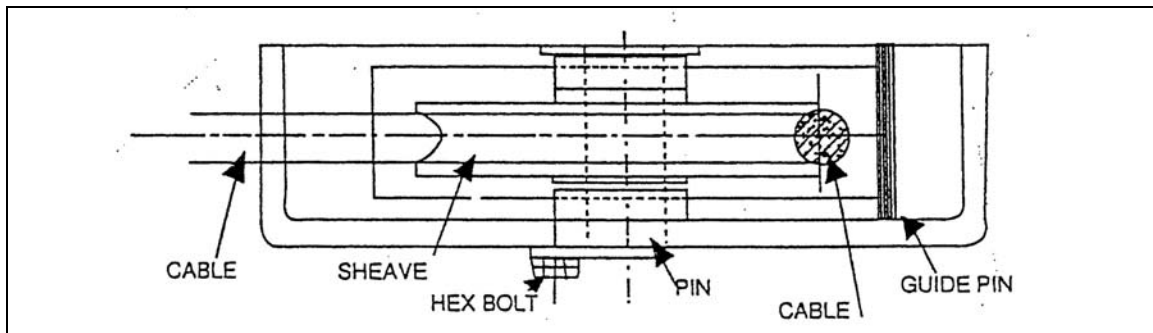

Figure 5. Sheave stack

NOTE: Typical deck sheave arrangement. Left and right front deck shown; cable must run between the welded guide pin and the groove in the sheave. Left and right front spacers have equal top and bottom sizes.

NOTE: Similar arrangement for sheave stack. Right deck rear spacer sizes are not equal - larger goes on top of stack.

- Continue to pull cable #4 over the center support of the right deck.
- Begin routing cable #3 (Part # 2-0541) from the right rear crossmember assembly using the non threaded end of the cable as described in Figure 3, and out through the crossmember assembly to the opening under the rear of the right deck.

TIP: TAPE THE TWO CABLES TOGETHER, CABLE #3 ON TOP OF CABLE #4. THIS WILL KEEP THE TWO CABLES FROM TWISTING IN THE REAR CROSSMEMBER ASSEMBLIES.

- Continue to feed cables #3 and #4 through the rear crossmember assembly and out of the opening under the rear of the left deck.
- Install the sheave into the rear of the right deck as shown in Figure 4.
- Route cable #2 (Part # 2-0540) from the left side of the rear crossmember assembly using the non threaded end of the cable as described in Figure 3, and out through the crossmember assembly to the opening under the rear of the left deck.
- Route cable #1 (Part # 2-0539) from the left side of the front crossmember assembly using the non threaded end of the cable as described in Figure 3, and out through the crossmember assembly to the opening under the front of the left deck.
- Install the sheave into the front of the left deck as shown in Figure 4.

NOTE: MAKE CERTAIN THAT ALL CABLES ARE IN THE RIGHT POSITIONS AND ARE NOT TWISTED. VERIFY THAT ALL FOUR (4) OF THE 3/8"-16 UNC × 2 3/4" LG. HEX HEAD BOLTS ARE REINSTALLED ON THE CROSSMEMBER ASSEMBLIES.

- Install the sheave stack assembly at the rear of the left deck as shown in Figure 4. Sheaves installation.

NOTE: ALL POSTS HAVE THE SAFETY RACKS ALREADY INSTALLED. THE LEFT FRONT POST WILL HAVE A MOUNTING BRACKET FOR THE POWER PACK INSTALLATION.

- Stand posts into position according to Figure 1
- Install the threaded stud end of the cables through the top of the post. Use a 7/8" flat washer, and two (2) 7/8"-14 UNF hex nuts with cable spacers as required, to compensate for uneven floors.
- Non-threaded cable ends will be installed after hydraulic installation (section 4.7).

4.5 POWER PACK INSTALLATION

- Bolt the power pack to the mounting bracket on the front face of the left front post using four (4) 5/16"-18UNC × 1"LG. hex head bolts and four 5/16" lockwashers. Refer to Figure 6.

NOTE: WHEN WORKING WITH HYDRAULIC LINES AND VALVES, IT IS IMPORTANT TO KEEP ALL COMPONENTS CLEAN AND FREE OF DIRT.

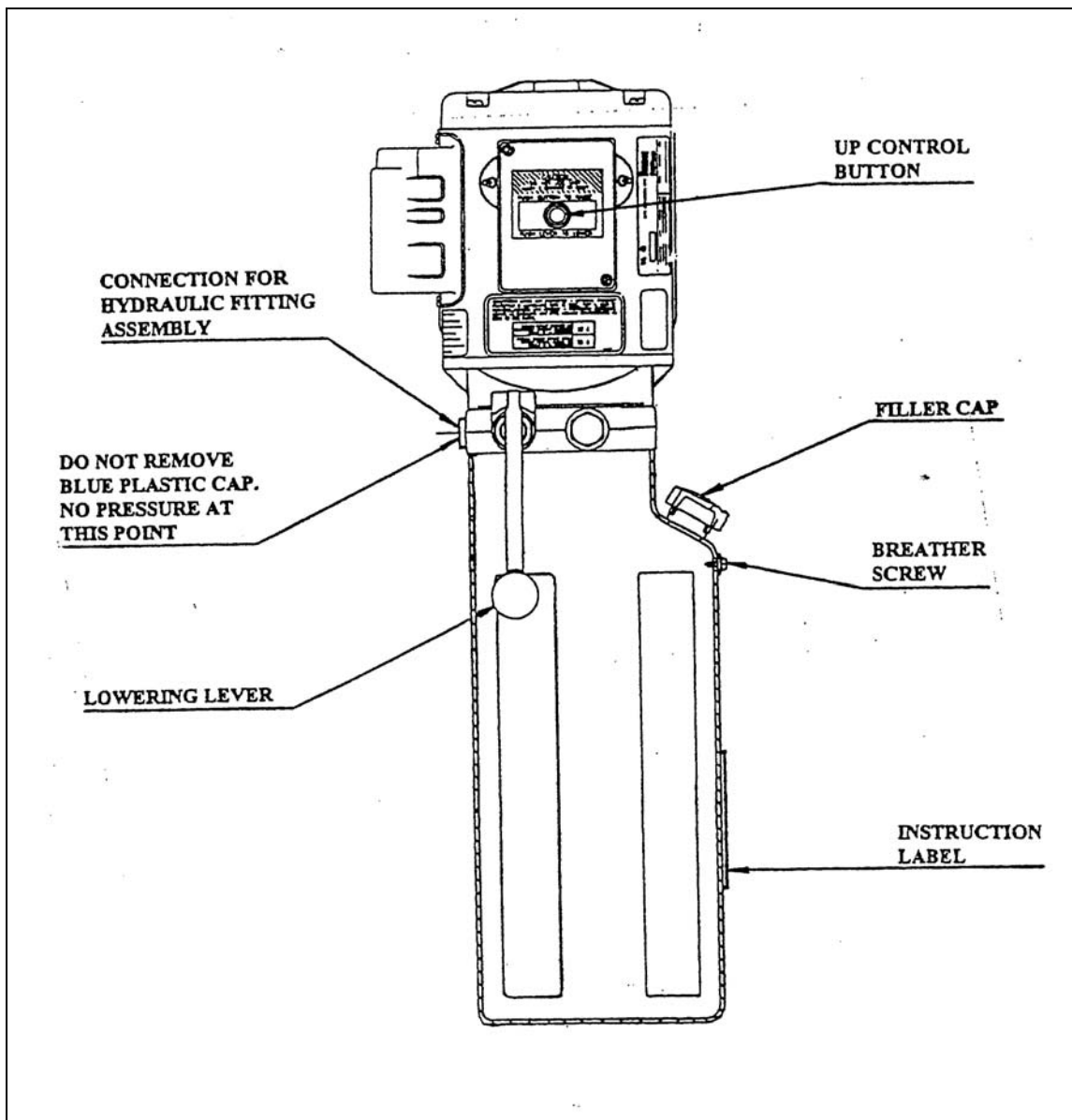

Figure 6. Power pack details

4.6 ELECTRICAL CONNECTIONS

CAUTION: ALL ELECTRICAL CONNECTIONS SHOULD BE MADE BY A QUALIFIED ELECTRICIAN.

Please refer to

Figure 7, Electrical Diagram for electrical connections.
Electrical Breaker Size Recommendation: 20Amps

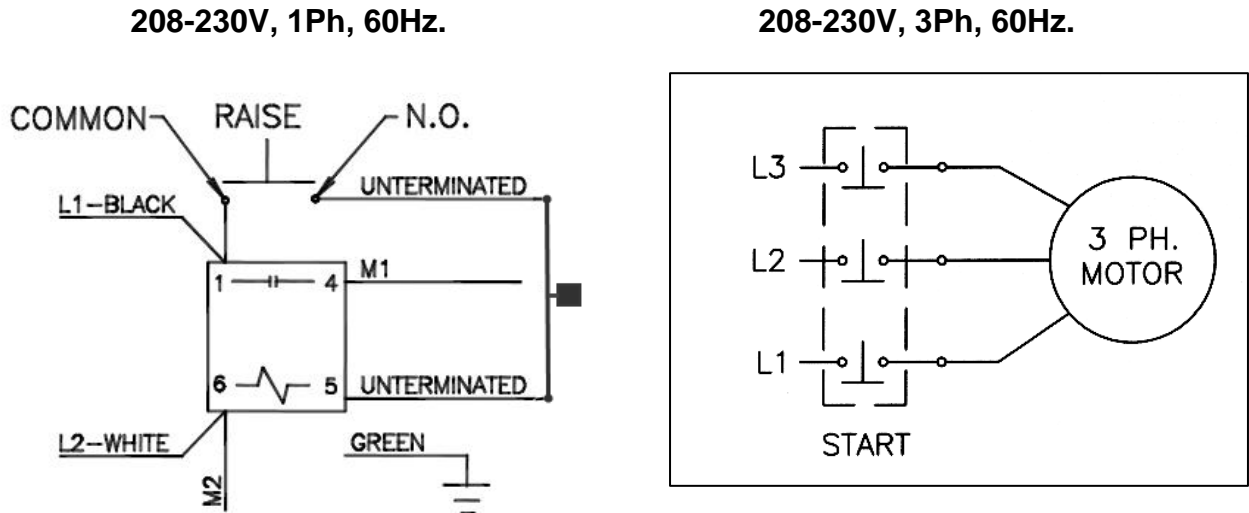

Figure 7. Electrical diagram for 230V/1 Ph and 230V/3 Ph

4.7 HYDRAULIC INSTALLATION

- Refer to Parts Manual, Hydraulic and Air Kit Diagram

TIP: TAPE ONE END OF THE HYDRAULIC HOSE TO THE TWO POLYTUBES AND FEED THEM THROUGH THE BLACK PLASTIC PIPING. THEN REMOVE THE TAPE.

- Connect 3/8" JIC, M end of the flexible hydraulic hose to the fitting at the cylinder.

DO NOT OVER TIGHTEN.

- Install flow control assembly.
- Attach the other end 3/8" JIC, F of the flexible hydraulic hose to the adapter fitting on the power pack (3/8" JIC, M).

NOTE: THE PLASTIC PLUG ON THE POWER PACK IS NOT USED. THERE IS NO HYDRAULIC PRESSURE.

NOTE: THE CYLINDER ROD MUST BE EXTENDED IN ORDER TO INSTALL THE NON-THREADED END OF THE CABLES TO THE CABLE FLANGE ON THE ROD.

- Remove the hydraulic cap from the fitting at the base of the hydraulic cylinder.
- Use an air chuck and blow air into the fitting in the breather hole in the base of the cylinder to extend the rod.

NOTE: AS ROD EXTENDS, OIL FROM CYLINDER RETURNS TO POWER PACK. RELEASE HANDLE ON POWER PACK NEEDS TO BE HELD DOWN (OPEN) TO ALLOW OIL TO RETURN TO POWER PACK.

- Continue to extend the rod until the non-threaded ends of the cables are reached.
- Remove the clamp from the cable flange. Ensure that the cable flange is installed with the counterbores facing towards the hydraulic cylinder as shown in Figure 8.
- Install the cables as shown in Section 8.5, Cable and Routing Diagram.
- Tighten the hose clamp on the cable flange to secure all the cables. Ensure that the two retaining nuts are positioned as shown in Figure 8. Using two wrenches, lock the retaining nuts against each other.

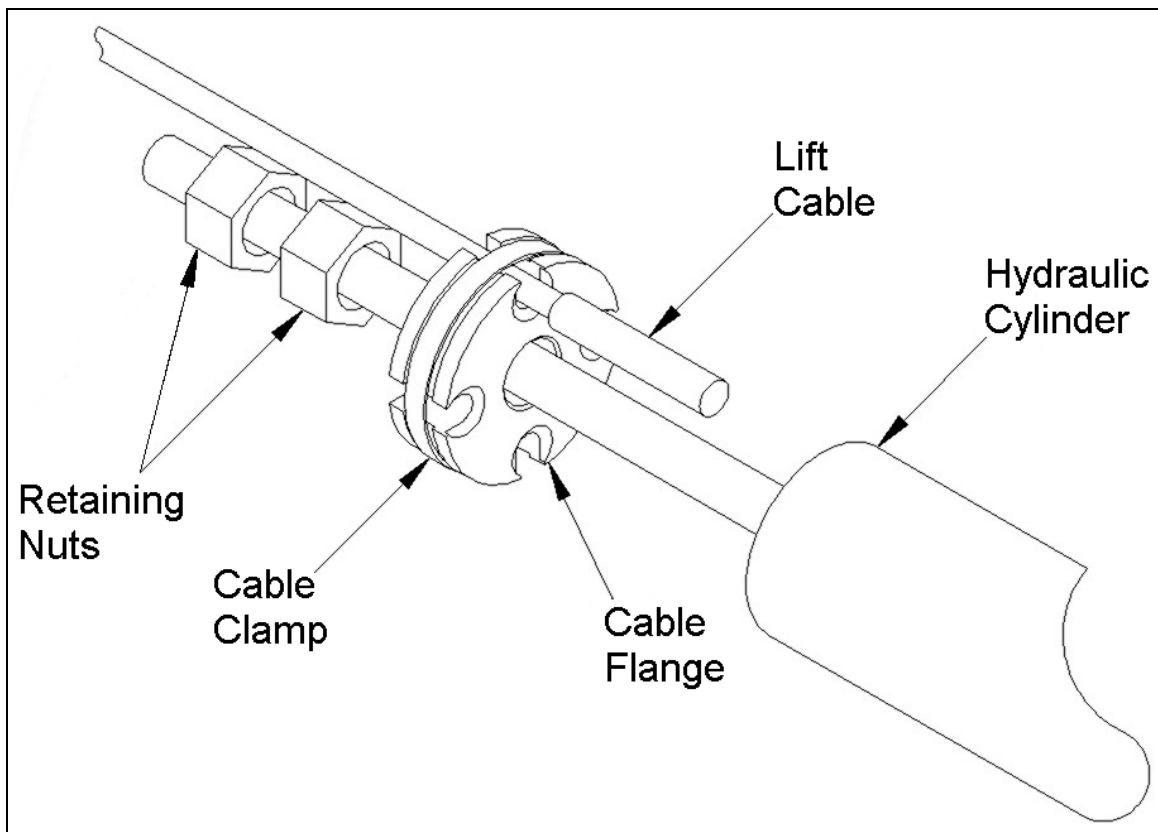

Figure 8. Cable Installation at Flange

HYDRAULIC AND AIR KITS INSTALLATIONS

- Locate the supply lines: 1/4" and 3/8" polytube, 3/8" flexible hydraulic line, and the black plastic piping.
- Install the black plastic piping to the steel pipe welded to the underside of the front left side crossmember assembly.

4.8 AIR INSTALLATION

- Attach the air valve assembly using two (2) #8 - 32 UNC × 1"lg. Phil. HD. screws to the two (2) #8 - 32 UNC hex nuts on the outside face of the left front post.

NOTE: MOST OF THE 1/4" AND 3/8" POLYTUBE CONNECTIONS HAVE BEEN MADE IN THE CROSSMEMBERS ASSEMBLIES AND LEFT DECK. ONLY FINAL CONNECTIONS ARE REQUIRED TO BE MADE. THE 1/4" POLYTUBE WILL BE USED FOR THE AIR CYLINDER LOCKS AND THE 3/8" POLYTUBE WILL BE USED FOR THE AIR OUTLETS TO THE JACKING BEAMS.

CAUTION: DO NOT OVER TIGHTEN CONNECTORS.

- Connect all of the 1/4" polytubes, which have been previously installed, coming out of the black plastic piping at the left front crossmember assembly, to the cross and tee pushlock fittings at the front and rear of the left deck. See the Hydraulic & Air diagram (Page 33).
- Connect the opposite end of the 1/4" polytube, coming out of the black plastic piping, to the air valve on the outside face of the left front post.
- Connect the 3/8" polytube, coming out of the black plastic piping at the left front cross-member assembly, to the 3/8" polytube fitting at the front inside under the left deck.
- Connect the opposite end of the 3/8" polytube, coming out of the black plastic piping, to the air valve outlet on the outside face of the left post.

NOTE: FOR THOSE UNITS EQUIPPED WITH JACKING BEAMS, THIS WOULD BE THE TIME TO INSTALL THEM. CONSULT THE JACKING BEAM INSTRUCTIONS MANUAL FOUND IN EACH JACK BEAM BOX.

- IF JACK BEAMS ARE NOT INSTALLED, USE PLUGS AND/OR COUPLERS TO PLUG AIR OUTLETS.

- Hook up an air supply to the inlet of the water trap on the air valve assembly located on the outside of the left post.
- Check for air leaks.
- Check the operation of the air cylinder locks by depressing the air valve on the outside of the left front post.

- Fill reservoir with hydraulic oil. (ISO 32 10 weight)
- Press the “UP” button on the hydraulic power unit. Continue raising until the lift is supported by the cables.

NOTE: MAKE CERTAIN THAT THE MECHANICAL SAFETY LOCKS AND CABLE ROLLERS ARE WORKING PROPERLY.

4.9 SAFETY RETAINING SYSTEM

- Assemble the safety retainer bracket assemblies using the supplied hardware as shown in Section 8.7
- Install one 5/16”x 3/4” long hex head bolt with one 5/16” lock washer and one 5/16” flat washer into the top mounting hole location on the crossmember but do not tighten. Leave at least 3/16” space between the lock washer and the crossmember.
- Insert the bracket assembly inside the post and slide up into place between the post and the crossmember so that the bolt and washers slide into the upper slot.
- Install the second 5/16”x 3/4” long hex head bolt and 5/16” lock washer and flat washer through the lower slot and into the bottom mounting hole in the crossmember. Tighten both of the bolts. See Figure 9.
- Repeat for all sides of crossmembers.

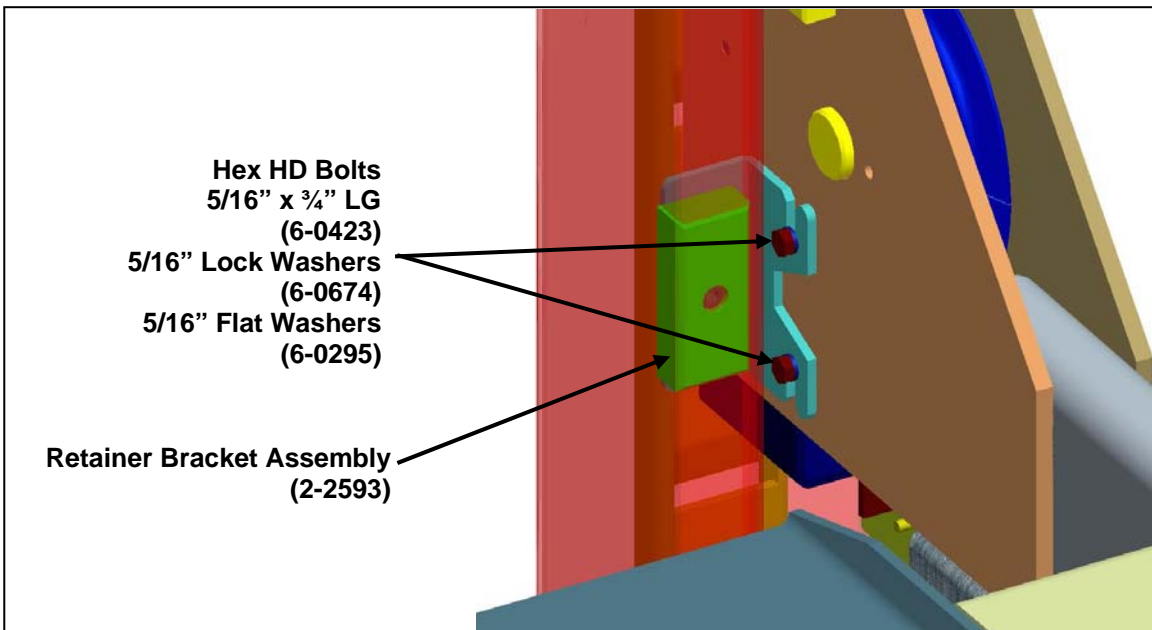

Figure 9. Retainer bracket installation

4.10 LEVELING PROCEDURE - CABLES

NOTE: Use a four (4) foot level to adjust the cables to level the decks side-to-side and front-to-rear. All cable adjustments can be made at the threaded end of the cable at the top of each of the four (4) posts.

- Tighten the two (2) 7/8" - 14 UNF hex nuts on each cable at the top of each post.
- Raise the lift to check operation.
- Lower lift by depressing the air valve while pulling down on the release lever of the power pack.
- Remove hand from air valve and allow the lift to hang on the cables.
- Use a four (4) foot level. Level and square all four posts.
- Begin leveling the highest post. Figure 10.

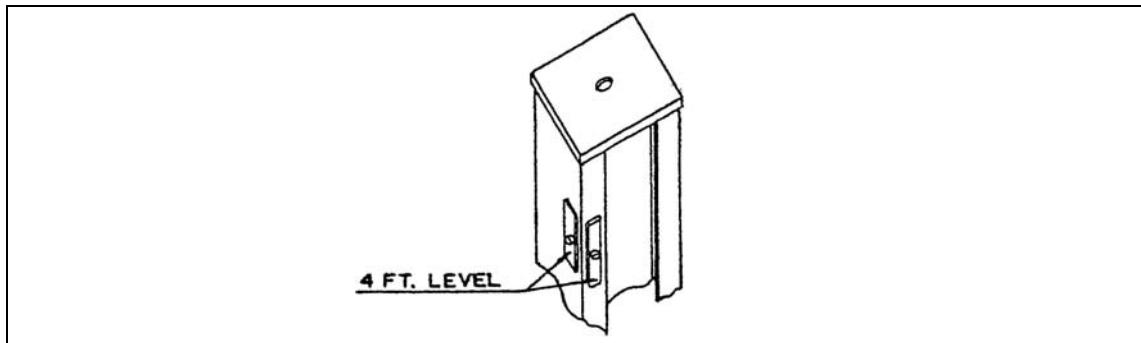

Figure 10. Post leveling

NOTE: MAKE CERTAIN THAT THE SAFETY RACK IN EACH OF THE POSTS IS SQUARE TO THE CROSSMEMBER ASSEMBLY AND THAT A MINIMUM CLEARANCE OF 1/8" IS MAINTAINED BETWEEN THE INSIDE FACE OF THE POSTS AND THE PLASTIC GUIDES ON THE CROSSMEMBER ASSEMBLY.

CAUTION: USE THE CORRECT WEDGE ANCHOR BOLTS. (SUPPLIED)

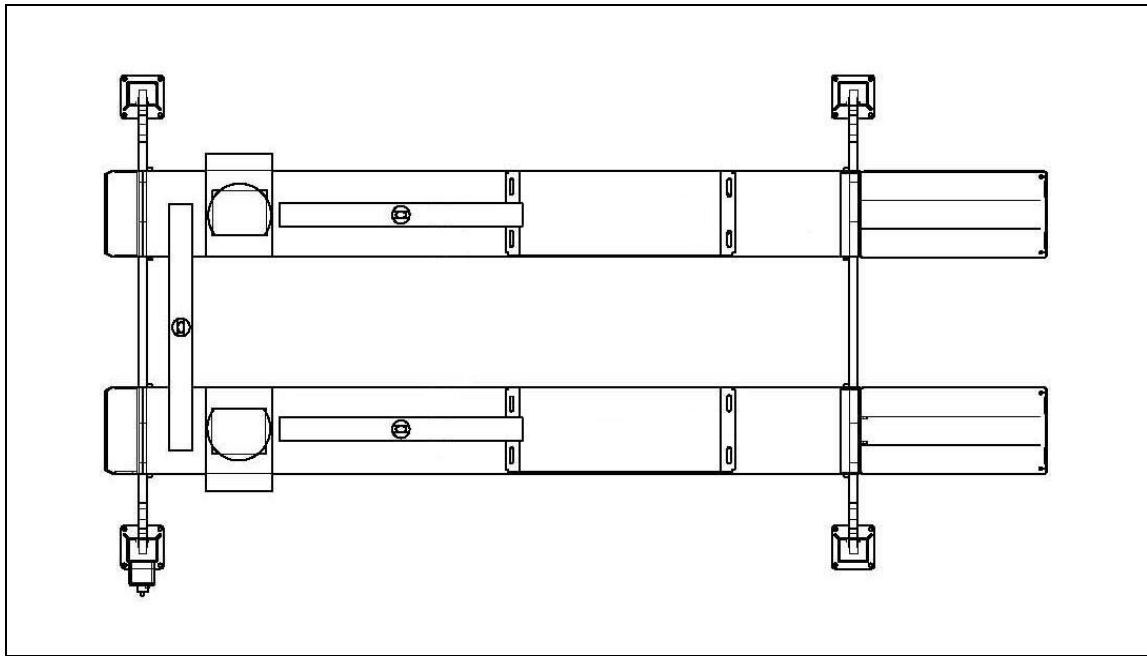

Figure 11. Deck leveling

NOTE: Check and adjust the decks for level using the 4' level. Both the front plate cut-outs and rear steer plates should be checked.

4.11 ANCHOR INSTALLATION

1. Refer to Figure 12 while reading through these instructions.

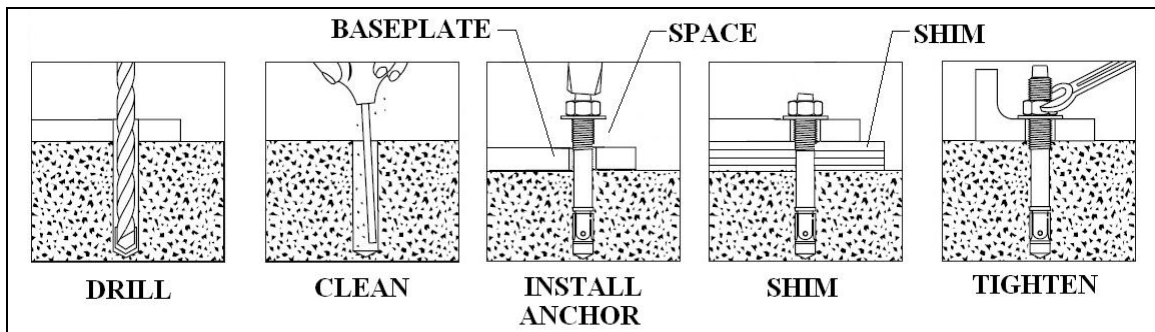

Figure 12. Anchor installation

2. Ensure that the lift is fully supported by the cables and is at a level just above the work stands.
3. Prior to installing anchors, assemble the nut and washer onto anchors. A minimum of six threads must be visible below the surface of the nut.
4. Using a 3/4" concrete drill bit and rotary hammer drill, drill through the concrete floor in the anchor holes positioned on the base of each post. (In case longer anchors are required, supplied anchors can be hammered through concrete).

5. Using a hammer, drive each anchor into floor leaving space for shimming.
6. Use a 4' level, to level the posts. Refer to Figure 14.
7. Shim as required and hammer anchors till they make contact with Baseplate. Do not tighten anchors.
8. Check the distance from the top of the anchor to the floor. If this dimension exceeds 2 1/4" due to floor slope, **DO NOT** use the supplied anchors. Longer anchor must be used (see #2 above).
9. Tighten all anchor bolts to a torque of 150 ft. lbs. Recheck and adjust the level of post(s) and cable(s) if necessary.

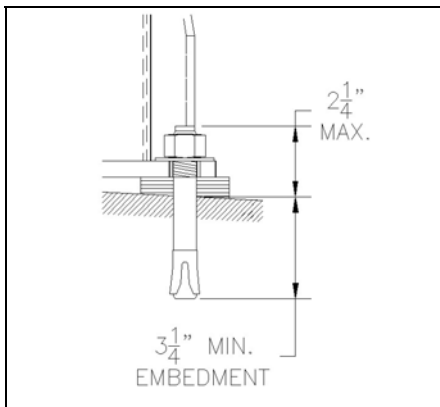

Figure 13. Floor slope

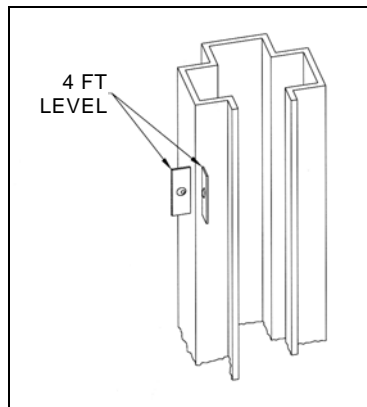

Figure 14. Post leveling

NOTE:

The 3/4" × 5 1/2" lg. wedge anchor bolts supplied must have a minimum embedment of 3/4" into concrete floor.

4.12 LEVELING PROCEDURE – SAFETY LADDERS

1. After the lift has been leveled on the cables, adjust the safety racks.
2. To check the mechanical safety locks, raise the lift up; make sure all locks engage at the same time making one noise. If the safeties are off slightly, gently bump the up button until you hear the first safety lock engage. Determine at which post the safety engaged; adjust each of the other safety racks until you hear the safety engage. Recheck to make certain that the safeties are engaging together.
3. To do this loosen the 3/8" - 16 UNC × 1" lg. hex bolt at the bottom back of each post and pull safety racks up until they come into full contact with each of the safety shoes on the crossmember assembly.
4. When level, tighten the two (2) 5/8" - 11 UNC hex nuts at the top of each safety rack and the 3/8" - 16 UNC × 1" lg. hex bolts at the bottom back of each post.
5. Raise the lift to check for full operating height of 71". This measurement is taken from the top of the decks to the floor.

6. Install approach ramps using ramp pins and cotter pins provided. Ensure the proper operation of the ramps.
7. Install front wheel stops using six (6) 1/2" - 13 UNC × 1" lg. hex bolts and 1/2" lockwashers.
8. Install the four (4) sheave covers over the sheaves in the crossmember assembly.
9. Cycle the lift several times to check proper operation of the cables, safety lock, air locks, etc.

STOP IMMEDIATELY IF THE LIFT IS NOT OPERATING PROPERLY.
Adjust and recheck for proper operation.

4.13 FINAL CHECK OF ASSEMBLED LIFT

1. Final dimension check after anchoring. _____
2. Check for air and hydraulic leaks. _____
3. Ensure cables are properly routed and free from obstructions. _____
4. Ensure all safety lock mechanism are working correctly. _____
5. Re-check level of post and decks. _____
6. Makes sure ramps are secured correctly with cotter pins and washers. _____
7. Check all fasteners, tighten if necessary. _____
8. Check direction of flow control (arrow pointed toward power unit). _____
9. If jack beams are supplied, ensure keeper bracket are installed. _____
10. Check jam nuts on cables and safety ladders are tightened. _____
11. Ensure cable flange clamp is installed correctly and tighten. _____
12. Ensure cylinder shaft Jam Nuts are installed as per instructions. _____
13. Ensure wheelstops are installed. _____
14. Ensure wheel chocks are provided. _____
15. Operate lift to full stroke then lower to ground while checking for proper functionality. _____
16. Ensure Customer Care Kit is complete and given to operator. _____
 - a. Operation Manual _____
 - b. ANSI / ALI Lift It Right Manual _____
 - c. ANSI / ALI Safety Tip Card _____
 - d. ANSI / ALI ALIS Safety Requirements for Installation and Service of Automotive Lifts _____
 - e. ANSI / ALI Quick Reference Guide _____
17. Train end user on operation of the lift. _____

4.14 OPERATION TEST WITH VEHICLE

1. Lower lift to ground.
2. Drive vehicle on to lift, install wheel chocks (Front & Back).
3. Raise lift to and lower onto 3-4 lock positions during full rise to ensure all locks are working correctly.
4. Double check level of runways, front to rear and side to side while on locks.
5. Re-adjust cables if necessary while vehicle is on.
6. Check lowering speed and smooth decent rate.
7. Lower lift to ground, remove wheel chocks and drive vehicle off lift.

If any problems occur during the final checkout or operation of the lift please contact customer service at 1-800-268-7959

5.0 SAFETY AND OPERATING INSTRUCTIONS

1. **Inspect** your lift daily. Do not operate it if malfunctions occur or damaged parts have been found.
2. **Never** attempt to overload the lift. The manufacturer's rated capacity is shown on the serial number tag on the power post.
3. **Operating controls, DO NOT OVERRIDE** the safeties. The mechanical safeties are designed to engage automatically on the way up. Press the up switch of the power pack to go up. When the desired height is reached, lower onto the safety. To lower, raise off of the safety locks, then press the air release valve and the lowering release lever at the same time.
4. **Only trained** and authorized personnel should operate the lift. Do **not** allow customers or bystanders to operate the lift or be in the lift area.
5. **Caution**, never work under the lift unless the mechanical safety locks are engaged.
6. **Before** driving vehicle on, make sure lift is in the fully down position.
7. **Before** removing the vehicle from the lift, make sure the lift is in the fully down position and ensure that all tools have been removed from the deck surfaces.
8. **Always** keep the lift area free from debris. Grease and oil spills should always be cleaned up immediately. **Never** leave any tools or parts lying on the decks.
9. **Never** operate lift with passengers in vehicle.

Installation shall be performed in accordance with ANSO/ALI ALIS, Safety Requirements for Installation and Service of Automotive Lifts.

For additional safety instructions regarding lifting, lift types, warning labels, preparing to lift, vehicle spotting, vehicle lifting, maintaining load stability, emergency procedures, vehicle lowering, lift limitations, lift maintenance, good shop practices, installation, operator training and owner/employer responsibilities, please refer to "Lifting It Right" (ALI/SM) and "Safety Tips" (ALI/ST).

For additional instruction on general requirements for lift operation, please refer to "Automotive Lift-Safety Requirements For Operation, Inspection and Maintenance" (ANSI/ALI ALOIM).

NOTE: DO NOT ATTEMPT TO OPERATE THIS LIFT IF ANY PART IS NOT WORKING PROPERLY OR YOU HAVE NOT READ THE COMPLETE OPERATING INSTRUCTION MANUAL.

NOTE: DO NOT RAISE OR LOWER THE LIFT WITH THE VEHICLE ON THE JACK BEAM

6.0 SAFETY AWARENESS

AUTOMOTIVE LIFT INSTITUTE (ALI)

⚠ CAUTION	⚠ CAUTION
Lift to be used by trained operator ONLY.	Authorized personnel only in lift area.

The messages and pictographs shown are generic in nature and are meant to generally represent hazards common to all automotive lifts regardless of specific style.

Funding for the development and validation of these labels was provided by the Automotive Lift Institute, PO Box 85 Cortland, NY 13045.

Replacement label sets may be obtained from the original lift manufacturer and ALI's member companies. They are protected by copyright.

www.autolift.org ©1992 by ALI, Inc. ALI/WL200c

SAFETY INSTRUCTIONS	SAFETY INSTRUCTIONS
Read operating and safety manuals before using lift.	Proper maintenance and inspection is necessary for safe operation.

SAFETY INSTRUCTIONS	<p>The messages and pictographs shown are generic in nature and are meant to generally represent hazards common to all automotive lifts regardless of specific style.</p> <p>Funding for the development and validation of these labels was provided by the Automotive Lift Institute, PO Box 85 Cortland, NY 13045.</p> <p>Replacement label sets may be obtained from the original lift manufacturer and ALI's member companies. They are protected by copyright.</p> <p>www.autolift.org</p> <p>© 1992 by ALI, Inc. ALI/WL200s</p>
Do not operate a damaged lift.	

⚠ WARNING	⚠ WARNING
Clear area if vehicle is in danger of falling.	Remain clear of lift when raising or lowering vehicle.

⚠ WARNING	⚠ WARNING
Keep clear of pinch points when lift is moving.	Keep feet clear of lift while lowering.

⚠ WARNING	⚠ WARNING
Do not override self-closing lift controls.	Chock wheel to prevent vehicle movement.

The messages and pictographs shown are generic in nature and are meant to generally represent hazards common to all automotive lifts regardless of specific style.

Funding for the development and validation of these labels was provided by the Automotive Lift Institute, PO Box 85 Cortland, NY 13045.

Replacement label sets may be obtained from the original lift manufacturer and ALI's member companies. They are protected by copyright.

www.autolift.org ©1992 by ALI, Inc. ALI/WL200w

7.0 RECOMMENDED MAINTENANCE GUIDELINES

Safety Instructions

- Read operating and safety manuals before using any lift
- Do not operate a lift that has been damaged or is in disrepair
- Proper inspection and maintenance is necessary for safe operation.
- An in-line filter/regulator/lubricator should be installed on all airlines and maintained weekly.

4-Post Lift: Daily

- Check general operation of lift.
- Check operations of mechanical safety locks.
- Check all air and hydraulic lines and fittings for pinch points, damage, cracks or leaks.
- Check all electrical wiring for pinch points, cracks or damage.
- Check operation of cables and pulleys.
- Check and drain water trapped in filter bowl.
- Check all moving parts for uneven or excessive wear.
- Repair or replace all damaged, defective, worn or broken components immediately.
- Clean roller jack rails

4-Post Lift: Monthly

- Check anchor bolts (if loose re-torque to 150 ft. lbs.). Replace concrete if anchors continue to loosen.
- Check all air and hydraulic hoses, fittings and cylinders for leaks.
- Check level of oil in power pack reservoir when lift is in the lowered position. Add if required.
- Check cables for fraying and adjustment. Lubricate cables with cable or penetrating oil every six months.
- Check all fasteners and tighten as required.
- Check all sheaves on crossmember assembly and under the runways for wear or play. Replace immediately. Pulley pins are held in place by 3/8" - 16UNC x 1"lg. Hex Head bolts. Make certain that these bolts are in position and tight.

WARNING!!!

DO NOT APPLY LUBRICANT TO SHEAVE ASSEMBLY. FIBRE BUSHING IS PTFE SELF-LUBRICATING. THE ADDITION OF LUBRICANT WILL SHORTEN THE LIFE OF THE FIBRE BUSHING.

- Check and adjust safety racks if lift is not level on safety, or if safeties do not engage properly.
- If lift is equipped with rear slip plates > dismantle, clean, touch up deck surface if required, and rotate bearing cage every four months (more frequent if necessary)
- Lubricate all safety shoes and locks every six months.
- Clean front turntable bearing cage with air.
- If lift is equipped with slide blocks, clean and re-grease slide block channels in each column every two months
- Change hydraulic oil every two years.

Quarterly Slip Plate Maintenance

- Remove top Slip Plate covers by first removing the four (4) shoulder bolts on each cover.
- Remove polyethylene-bearing cages insuring that all the Delrin bearings remain in the cages. Additional Delrin bearings may be purchased if required.
- Clean runway surface and touch up any paint wear with a rust resistant paint. Allow paint to dry thoroughly.
- To obtain optimum performance, the position of the slip-plate bearing cage should be rotated every quarter to change the wear pattern. With the first quarter maintenance, flip the bearing cage over to the opposite side. With the second quarter maintenance, rotate the bearing cage end-to-end. With the third quarter maintenance, flip bearing cage over to the opposite side. Fourth quarter maintenance should see the bearing cage rotated back to the position it started in.
- Quarterly maintenance will optimize performance and contribute to longer slip plate life.

Rolling Air Jacks

- An in-line filter/regulator/lubricator should be installed close to the pump. Add a few drops of oil to the air intake weekly if no lubricator is used or when idle for a long period of time.
- Lubricate roller bearings and roller guide springs every two months
- Dismantle and clean lift arms every four months
- Clean and lubricate lower cam rollers and hinge points every six months
- Clean and lubricate safety mechanism every six months
- Change hydraulic oil every two years

Lubrication

- | | |
|-----------------------------------|--|
| Where grease is required | > multi-purpose lithium grease |
| Where lubricating oil is required | > multi-purpose SAE 30 lubricating oil |
| Where hydraulic oil is required | > ISO 32 10W - non detergent hydraulic oil |

8.0 PARTS MANUAL

8.1 LIFT ASSEMBLY

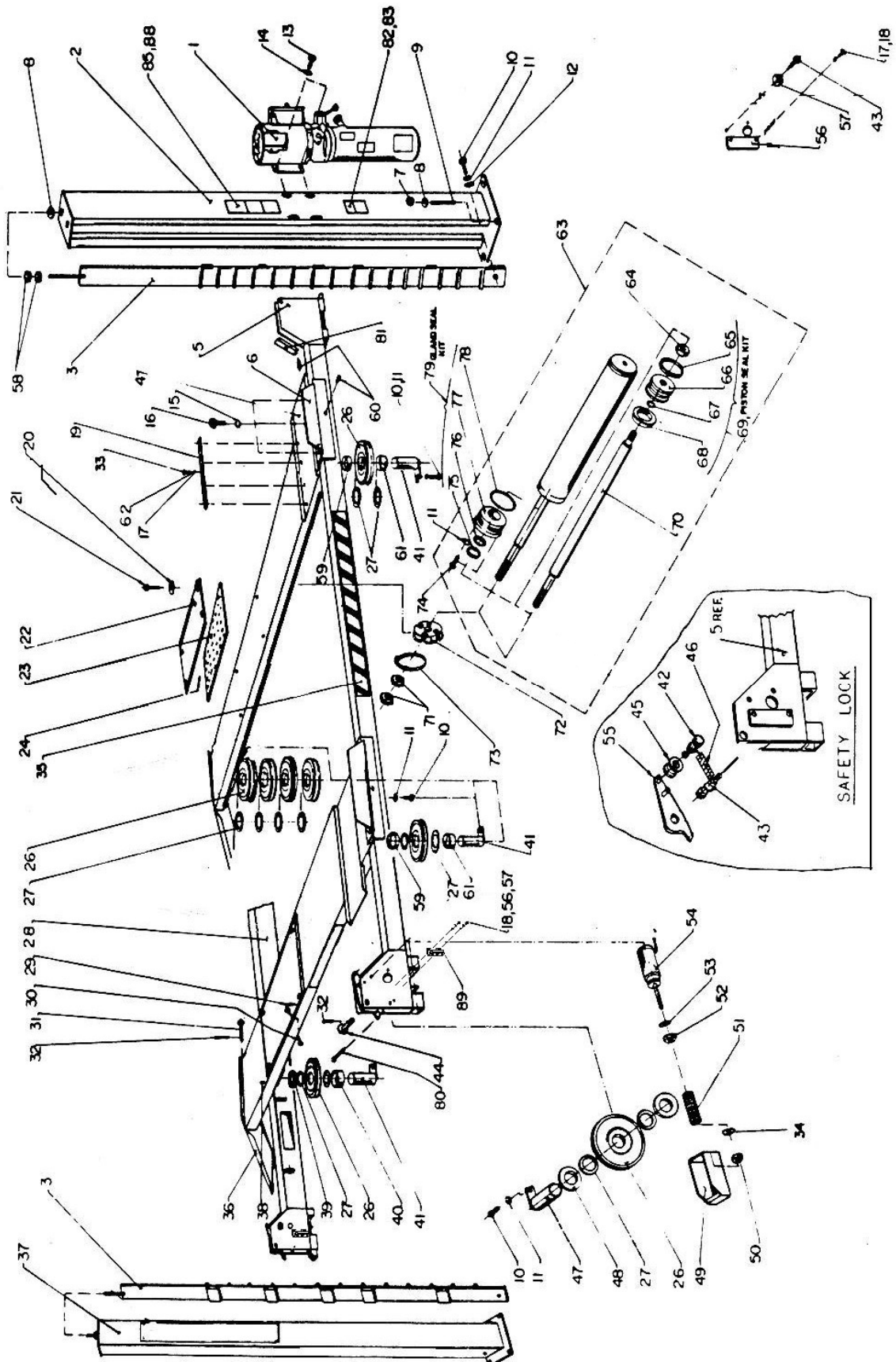

8.2 LIFT PARTS LIST

ITEM	QTY.	DESCRIPTION	PART#
1	1	POWER PACK, 230V/1PH/60HZ.	6-1936
	1	POWER PACK, 230V/3PH/60HZ.	6-1165
2	1	POWER POST	4-0186
3	4	SAFETY RACK WLDMT.	3-0487
4*	1	ALIGNMENT DECK WLDMT, (LEFT SIDE)	4-0183
5	1	FRONT CROSSMEMBER WELDMENT	4-0190
6	2	FRONT WHEEL STOP	2-0998
7	16	HEX NUT, 3/4"-10UNC	6-0737
8	24	FLAT WASHER, 3/4" I.D.	6-0738
9	16	WEDGE ANCHOR, 3/4"-10UNC X 5 1/2" LG.	6-1379
10	12	HEX HD. BOLT, 3/8"-16UNC X 1" LG. GR.8	6-0668
11	14	LOCKWASHER, 3/8" I.D.	6-0058
12	8	FLAT WASHER, 3/8" I.D.	6-0625
13	4	HEX HD. BOLT, 5/16"-18UNC X 3/4" LG.	6-0423
14	4	LOCKWASHER, 5/16" I.D.	6-0674
15	6	LOCKWASHER, 1/2" I.D.	6-0059
16	6	HEX HD. BOLT, 1/2"-13UNC X 1" LG.	6-0045
17	16	LOCKWASHER, 1/4" I.D.	6-0056
18	16	HEX HD BOLT 5/16"-18 UNC 3/4" LG	6-0423
19	4	RETAINING BAR	2-1391
20	8	FLAT WASHER, 13/32" I.D. X 2" O.D.	6-0426
21	8	SHOULDER BOLT, 3/8" DIA. X 5/8" LG.	6-0069
22	2	REAR SLIP PLATE	3-0197
23	2	BEARING CAGE	3-0196
24	1 SET	BALL BEARING	6-0829
26	11	SHEAVE ASSEMBLY	2-0557
27	21	NYLON THRUST WASHER	1-0757
28	1	REAR CROSSMEMBER WELDMENT	4-0188
29	4	LOCKING PIN ASSEMBLY	2-0637
30	4	SELF TAPPING SCREW, #10 X 1/2" LG.	6-0505
31	4	RAMP PIN	1-1887
32	4	COTTER PIN, 1/8" X 1 1/2" LG.	6-0978
33	12	HEX HD. BOLT, 1/4"-20UNC X 3/4" LG.	6-0178
34	8	FLAT WASHER, 1/4" I.D.	6-0060
35	2	"CAUTION" TAPE, (40" LG.)	6-1125
36	2	RAMP ASSEMBLY W/ ROLLER	3-0905
37	3	POST	3-0347
38**	1	ALIGNMENT DECK WLDMT, (RIGHT SIDE)	4-0184
39	1	SHEAVE SPACER, 2 1/2" LG.	1-0798
40	1	SHEAVE SPACER, 1 1/4" LG.	1-0788

ITEM	QTY.	DESCRIPTION	PART#
41	4	DECK SHEAVE PIN	2-0566
42	4	SHOULDER BOLT, 3/8"DIA. X 1 1/2"LG.	6-0801
43	4	SHOULDER BOLT, 3/8"DIA. X 5/8"LG.	6-0069
44	4	LOCK SAFETY PIN	1-0769
45	4	CABLE ROLLER	1-0766
46	8	TENSION SPRING	1-0768
47	4	CROSSMEMBER SHEAVE PIN	1-0771
48	8	SHEAVE SPACER, 3/8"LG.	1-0786
49	4	SAFETY SHOE WLDMT.	2-0990
50	4	HEX NYLON LOCKNUT, 1/4"-28UNF	6-1563
51	4	COMPRESSION SPRING	1-0767
52	4	HEX NUT, 5/8"-18UNF	6-0662
53	4	INTERNAL TOOTH LOCKWASHER, 5/8" I.D.	6-0663
54	4	AIR CYLINDER, 5 1/2" ROD LGTH. (SPR-12)	6-0651
55	2	SAFETY LOCK LS	2-0567
	2	SAFETY LOCK RS	2-1475
56	16	FLAT WASHER 5/16"	6-0295
57	16	LOCK WASHER 5/16" ID	6-0674
58	8	HEX NUT, 5/8"-11UNC, GR.8	6-0036
59	2	SHEAVE SPACER, 1 3/4"LG.	1-0799
60	8	SET SCREW, 1/2"-13UNC X 1"LG. GR.8	6-0726
61	2	SHEAVE SPACER, 2"LG.	1-0943
62	16	FLAT WASHER, 1/4"ID x 3/4" OD, PALTED	2-0843
63	1	HYDRAULIC CYLINDER	4-0393
64	1	LOCKNUT, 7/8"-14UNF	6-1160
65	1	WEAR RING	6-0004
66	1	PISTON	2-0564
67	1	"O" RING	6-1305
68	1	PISTON SEAL	6-0003
69	1	PISTON SEAL KIT	0-0169
70	1	PISTON ROD	2-0565
71	2	HEX NUT, 1"-14UNF-2A, GR.8	6-0664
72	1	CABLE FLANGE	2-1037
73	1	CLAMP	6-0665
74	2	HEX HD. BOLT, 3/8"-16UNC X 1 1/4"LG. GR.8	6-0666
75	1	ROD WIPER	6-0653
76	1	ROD SEAL	6-0654
77	1	GLAND	3-0348
78	1	"O" RING	6-0655
79	1	GLAND SEAL KIT	0-0170
80	4	HEX HD. BOLT, 3/8"-16UNC X 2 3/4"LG.	6-0730
81	4	SHEAVE COVER	2-0575

ITEM	QTY.	DESCRIPTION	PART#
82	1	SERIAL TAG	6-1115
83	1	ALI/ETL DECAL	6-0996
85	1	DECAL SET, ALI/WL 200	6-0988
88	1	“ATTENTION” DECAL	6-1637
89	8	SAFETY RETAINER BRACKET ASS’Y	2-2593

FOR SERVICE MODEL

*	1	SERVICE DECK WLDMT, (LEFT SIDE)	4-0195
**	1	SERVICE DECK WLDMT., (RIGHT SIDE)	4-0196

8.3 HYDRAULIC AND AIR KITS ASSEMBLY

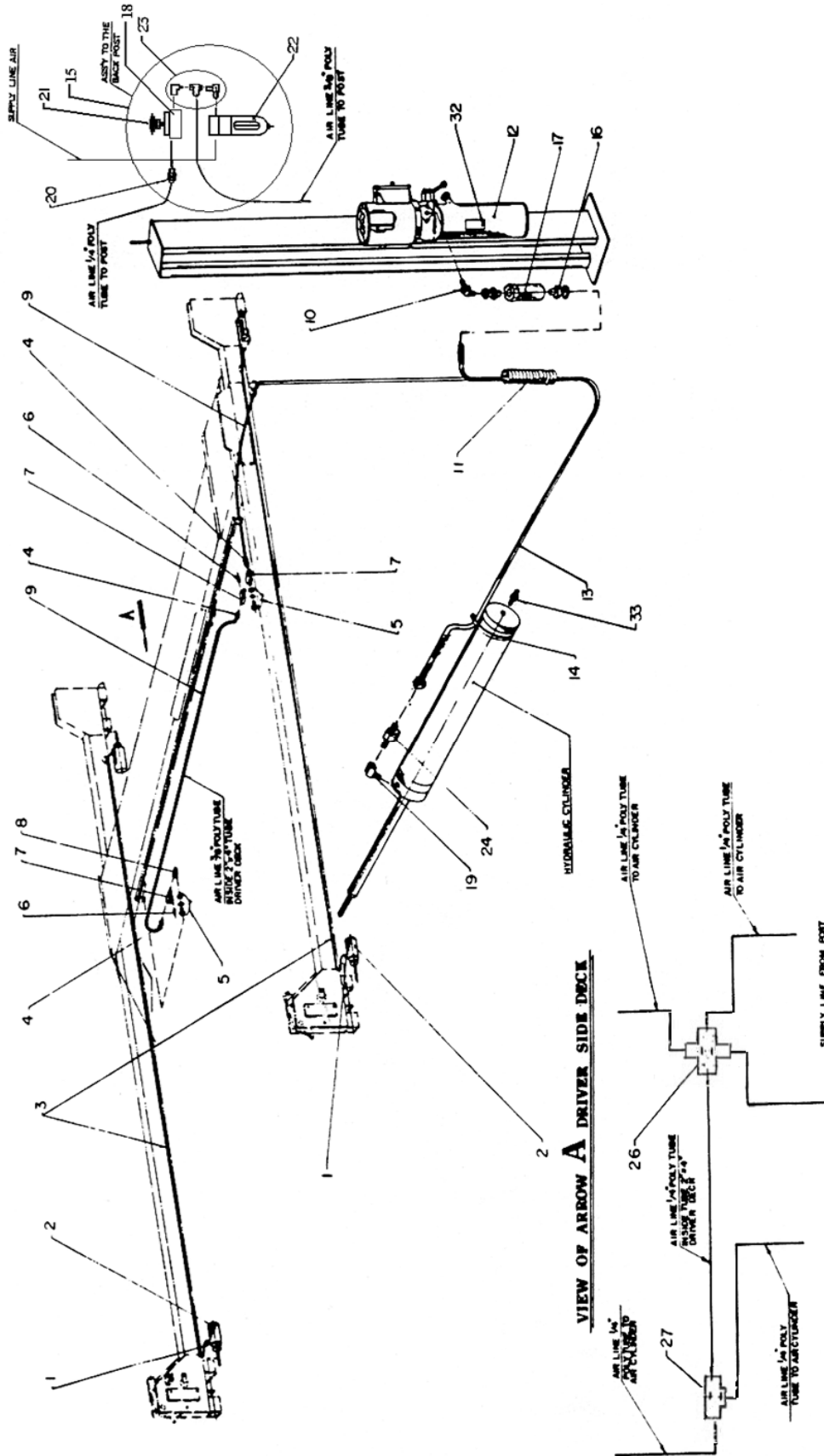

8.4 HYDRAULIC AND AIR KITS PART LIST

ITEM	QTY.	DESCRIPTION	PART#
1	4	90° ELBOW, 1/8"NPT X 1/4"POLY TUBE	6-0709
2	4	AIR CYLINDER	6-0651
3	50 FT.	1/4" DIA. POLY TUBE	6-0706
4	3	ADAPTER, 3/8" POLY TUBE X 1/4"NPT	6-0710
5	2	TERMINAL BOLT, 3/4"	6-0713
6	2	PLUG, 1/4"NPT	6-0282
7	3	1/4" NPT STREET TEE	6-0014
8	1	1/4" NPT STREET ELBOW	6-0015
9	25 FT.	3/8" DIA. POLY TUBE	6-0707
10	1	90° ADAPTER, 3/8"JIC M X 9/16"-18 M	6-0804
11	4 FT.	HOSE GUARD	6-0714
12	1	POWER PACK 230V/1PH/60HZ.	6-1936
	1	POWER PACK 230V/3PH/60HZ.	6-1165
13	1	HYD.HOSE ASS'Y, 3/8"SWIVELx3/8"JIC M, 147"LG.	6-0715
14	3	CABLE TIE	6-0731
15	1	AIR VALVE & FILTER ASS'Y	2-1394
16	2	ADAPTER, 3/8"NPT M X 3/8"JIC F, SWIVEL	6-0797
17	1	FLOW CONTROL	6-1937
18	1	3-WAY AIR VALVE	6-1775
19	1	90° ELBOW, 1/4"NPT M X 3/8"NPT F	6-0796
20	1	ADAPTER, 1/4" POLY TUBE X 1/8"NPT	6-0708
21	1	AIR VALVE PUSHBUTTON KIT	6-1777
22	1	AIR FILTER ASSEMBLY	6-0772
	1	AIR FILTER ELEMENT, (REPLACEMENT)	6-0180
23	1	AIR VALVE FITTING KIT	0-0405
24	1	VELOCITY FUSE	6-1684
25	1	PLUG, 1/8" NPT	6-0182
26	1	1/4" POLYTUBE PUSHLOCK CROSS	6-3869
27	1	1/4" POLYTUBE PUSHLOCK TEE	6-2971
32	1	"LIFT OPERATION" DECAL	6-0593
33	1	ADAPTER, 1/8"NPT M X 1/4"JIC M	6-0280

8.5 CABLE ROUTING DIAGRAM

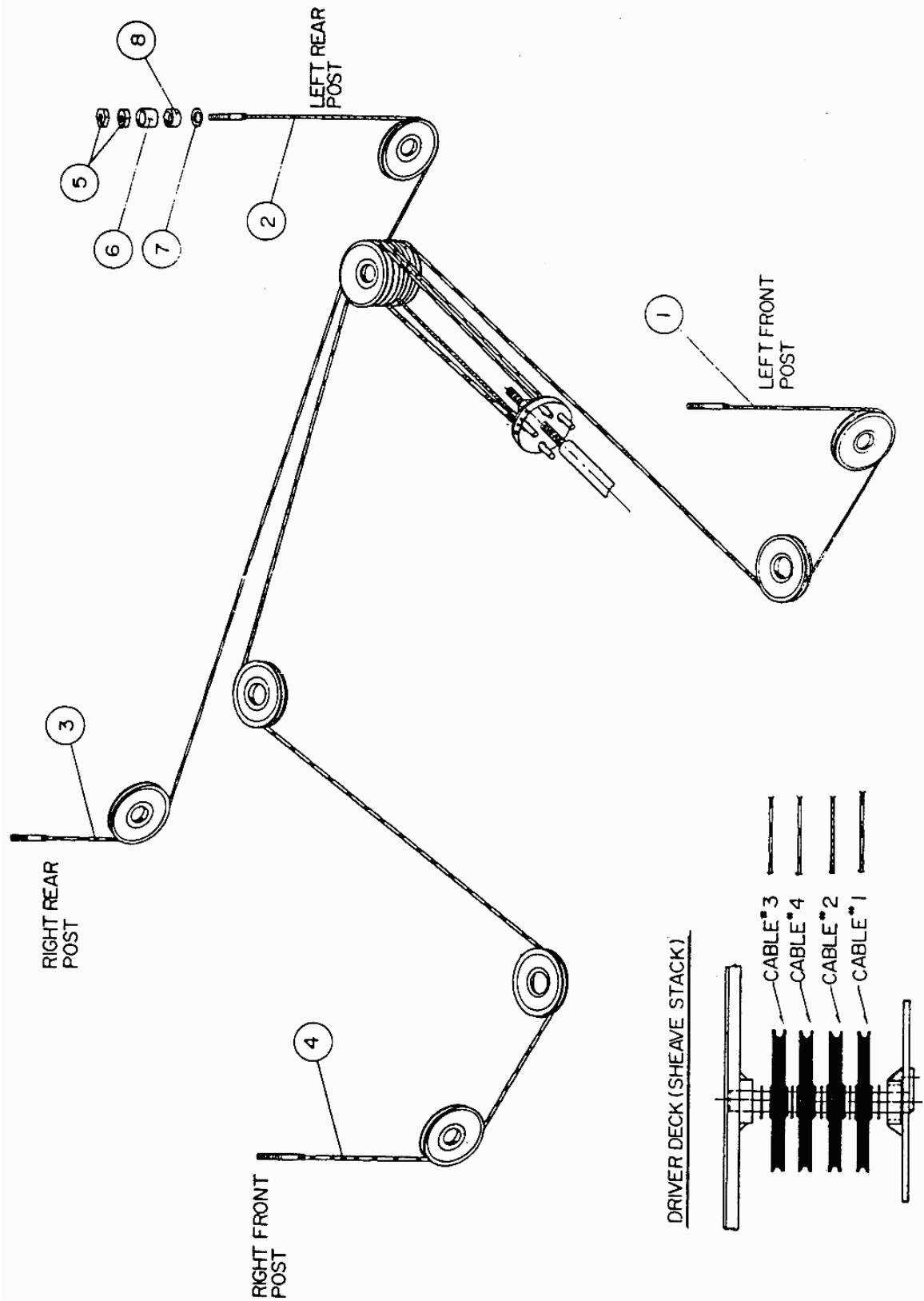

8.6 CABLE ROUTING PARTS LIST

ITEM	QTY.	DESCRIPTION	PART#
1	1	CABLE ASSEMBLY, 376"LG. (LEFT-FRONT)	2-0539
2	1	CABLE ASSEMBLY, 181"LG. (LEFT-REAR)	2-0540
3	1	CABLE ASSEMBLY, 233"LG. (RIGHT-REAR)	2-0541
4	1	CABLE ASSEMBLY, 427"LG. (RIGHT-FRONT)	2-0542
5	8	HEX NUT, 7/8"-14UNF, GR.5	6-0724
6	4	CABLE SPACER, 2"LG.	1-0800
7	4	FLAT WASHER, 7/8" I.D.	6-0725
8	4	CABLE SPACER, 1"LG.	1-0801

8.7 SAFETY RETAINER BRACKET

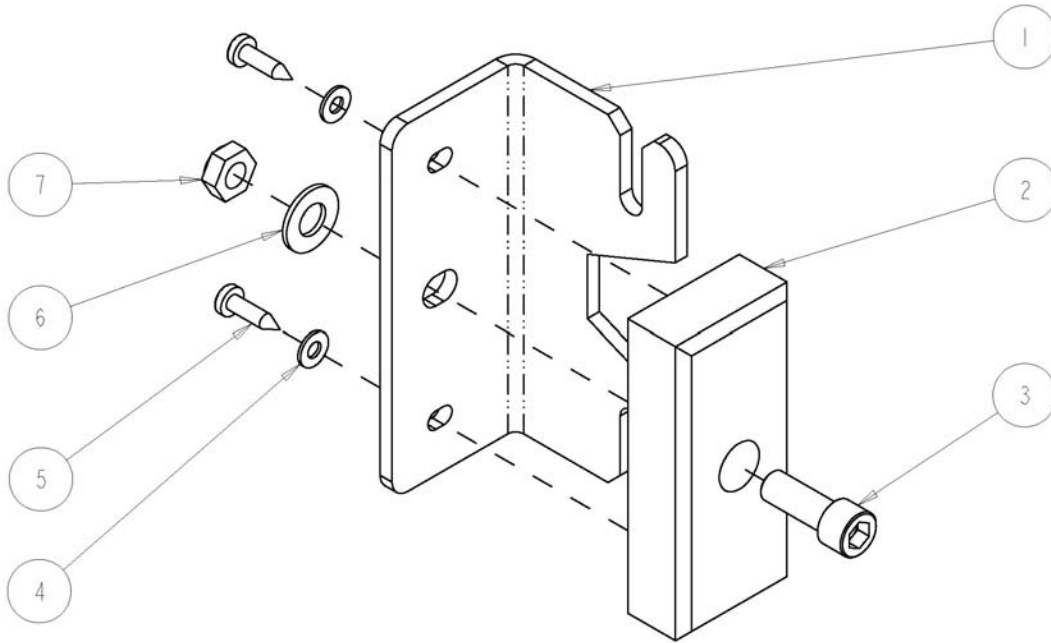

ITEM	QTY.	DESCRIPTION	PART #
1	8	SAFETY RETAINER BRACKET	2-2589
2	8	SAFETY RETAINER PAD	1-1674
3	8	SHCS 3/8" NC x 1" LG	6-2048
4	16	FLAT WASHER #10	6-0816
5	16	SCREW, SELF TAPPING, #10 x 3/4" LG	6-0297
6	8	LOCK WASHER 3/8"	6-0058
7	8	HEX NUT 3/8"-16 UNC GR5 PL	6-0034

8.8 POWER PACK

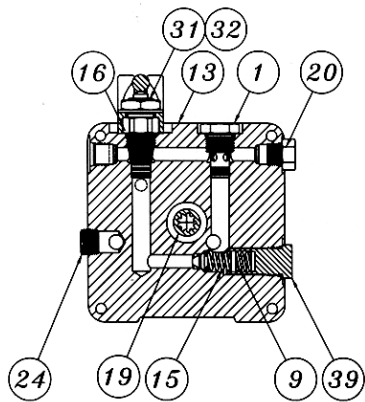
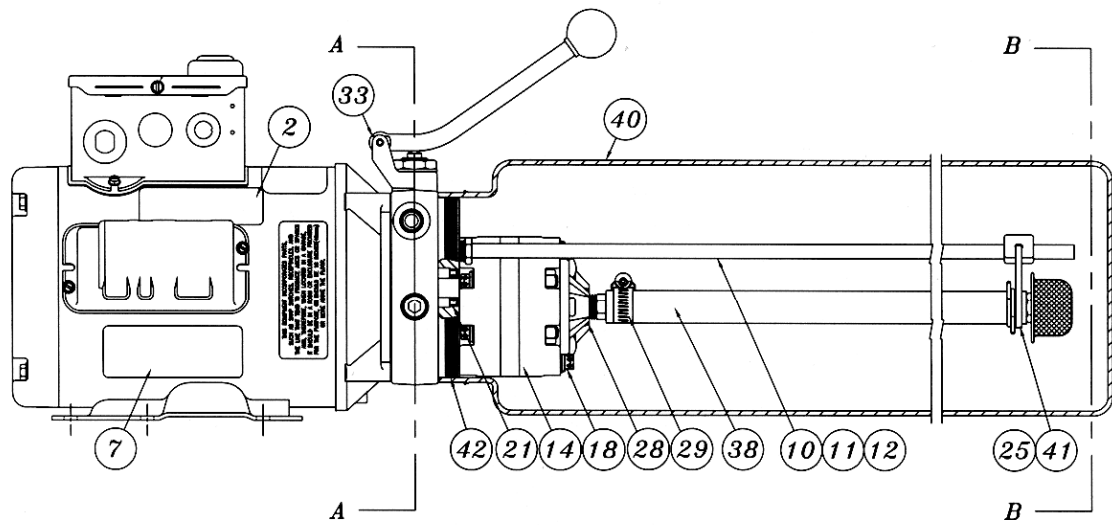
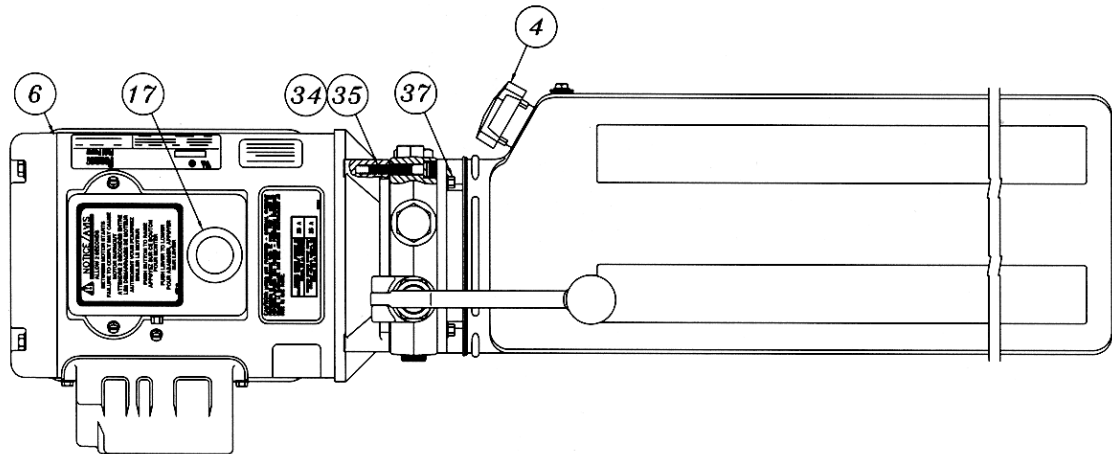

A-A

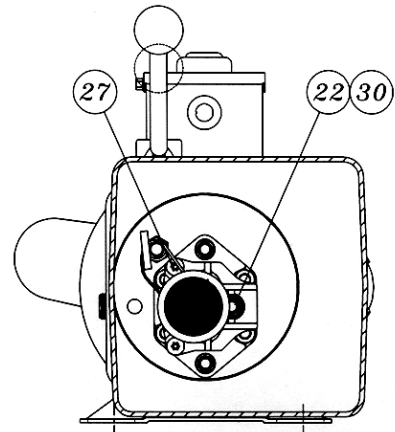

B-B

8.9 POWER PACK PARTS LIST

#6-1936 (AB-1400) 208-230V/1PH/60Hz

#6-1165 (AD-1044) 208-230V/3PH/60Hz

ITEM	QTY.	DESCRIPTION	PART #
1	1	VALVE CARTRIDGE CHECK	6-1087
2	1	LABEL INSTALLATION AUTOHOIST	6-2136
4	1	BREATHER CAP & BLADDER	6-1376
6	1	MOTOR AC 208-230V. 2HP/1PH/60Hz, BLK	6-2139
	1	MOTOR AC 208-230V. 2HP/3PH/60Hz, BLK	6-1079
7	1	LABEL WARNING AUTOHOIST	6-2149
9	1	SPRING 0.480" x 0.063" x 0.42" COMP	6-2151
10	1	RETURN HOSE 3/8" OD x 21.5"	6-2152
11	1	COMPRESSION TUBE NUT	6-2153
12	1	COMPRESSION TUBE SLEEVE	6-2154
13	1	ENDHEAD UNIVERSAL AUTOHOIST	6-2155
14	1	PUMPASSY 3.1 CC/REV. SHORT SPLINE	6-1688
15	1	RELIEF ASSEMBLY FIXED 170 BAR	6-1317
16	1	VALVE CARTRIDGE RELEASE MANUAL	6-0880
17	1	WIRING ASSEMBLY AC 1PH FENNER	6-2156
	1	WIRING ASSEMBLY AC 3PH FENNER	6-0918
18	2	BOLT 5/16"-24 x 3.00" TORX G8	6-1090
19	1	COUPLING SAE 9T-20/40 1.260"	6-0774
20	1	PLUMBING PLUG 9/16" SAE	6-2157
21	1	SEAL SHAFT 0.500" x 1.00" x 0.25"	6-2158
22	1	WASHER 0.338" x 0.625" x 0.060" STEEL	6-2159
24	1	PLUMBING PLUG 3/8" NPT	6-2161
25	1	PLUMBING MAGNET	6-2162
27	2	SCREW TAPTITE M6 x 1.0 12MM TORX	6-2164
28	1	COVER ASSY SUCTION	6-2165
29	1	PLUMBING CLAMP HOSE ADJ. INLET	6-2166
30	1	BOLT 5/16"-18 x 1.00" SHCS	6-1392
31	1	NUT 3/4"-16 x 1" HEX x 0.250" STEEL	6-2167
32	1	WASHER 3/4" INT. TOOTH LOCK	6-2168
33	1	BRACKET - HANDLE ASSY REL BLACK	6-0776
34	4	BOLT M6 x 1.0 35MM SOC HD	6-2169
35	4	WASHER 1/4" LOCK HI-COLLAR	6-2170
37	4	BOLT #12-24 x 0.50" HEX WSHRHD	6-1091
38	1	PLUMBING ASSY INLET 17.24 (3)	6-0786
39	1	RELIEF VALVE CAP ASSEMBLY	6-1089
40	1	TANK PLASTIC 6.7 OS 22.50" BLK	6-1399
41	1	CABLE TIE 8" LONG WHITE	6-1846
42	1	O-RING 2-348 BUNA	6-0875

CAUTION

ALL SAFETY LADDERS USED ON 4-POST LIFTS ARE PRELOADED.

REMOVING THE BOLT HOLDING THE BOTTOM PORTION OF THE SAFETY LADDER WITHOUT PROPER PRECAUTIONS CAN RESULT IN INJURY.

PLEASE CONTACT CUSTOMER SERVICE FOR PROPER REMOVAL INSTRUCTIONS.

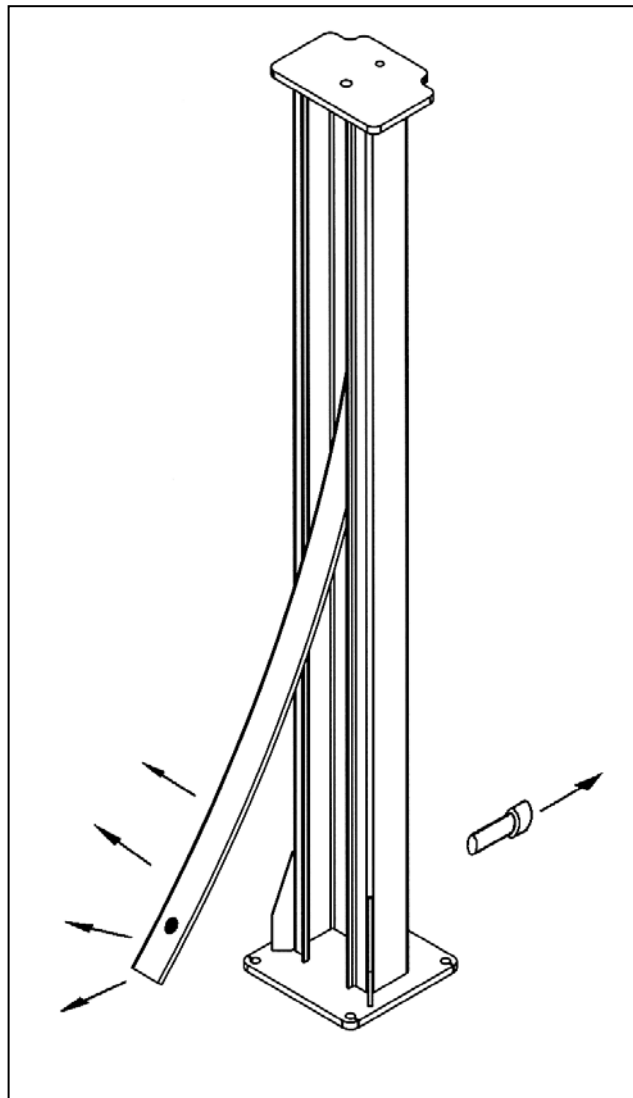

9.0 AVAILABLE ACCESSORIES

Hydraulic Jack Beams			
	Premium Air / Hydraulic Jack Beam		Standard Air / Hydraulic Jack Beam
4500 lb, 6000 lb, 7000 lb		6000 lb, 7000 lb	
Other Accessories			
	Drive-On Ramp Extension for Low Profile Vehicle (set of 2)		Air Outlet Kit (Factory Installed)
	Sliding Waste Collection Oil Tank 26 gal.		Drive-thru Kit (Quad Rack)
	Front Turning Radius Plates (set of 2)		Alignment Pan Cover, 4-Post
	Stainless Steel Turnplates		Rollback Kit (for Stainless Steel Turnplates)
	Air / Electric Service Station for 2-Post & 4-Post		Rear Slip Plate Refurb Kit - Stainless Steel Base (24" Decks Only - set of 2)
NO PICTURE AVAILABLE	Roll Forward Kit (4-Post)		Tsunami Kit (in-line compressed air dryer)

Accessories may not be available for all models. Contact supplier for availability and part numbers.