

SUN

INSTALLATION and OPERATION MANUAL



12000 SERIES

**READ THIS INSTRUCTION MANUAL THOROUGHLY BEFORE
INSTALLING, OPERATING, SERVICING OR MAINTAINING
THE LIFT. SAVE THIS MANUAL.**

OCT 2008 REV. - 6-1993

SUN is a trademark of
Snap-on Tools Corporation
1-800-268-7959

TABLE OF CONTENTS

PAGE

1	IMPORTANT SAFETY INSTRUCTIONS	3
2	SAFETY WARNING DECALS	5
3	SPECIFICATIONS	6
4	CONTENTS	7
5	TOOLS REQUIRED FOR INSTALLATION	7
6	INSTALLATION INSTRUCTIONS	7
6.1	BAY LAYOUT	8
6.2	UNPACKING PROCEDURE	9
6.3	HYDRAULIC INSTALLATION	10
6.4	ELECTRICAL INSTALLATION	10
6.5	MECHANICAL SAFETY INSTALLATION	12
6.6	FRONT AND REAR TIE BAR INSTALLATION	13
6.7	LEVELLING PROCEDURE	13
6.8	ANCHORING PROCEDURE:	15
6.9	INSTALLATION FOR ALIGNMENT MODEL	15
6.10	INSTALLATION FOR ALL MODELS	16
7	INSTALLATION OF 6000 LB. JACKING BEAM (SERIES 206 & 216)	17
8	OPERATING INSTRUCTIONS:	17
8.1	RAISING THE LIFT:	17
8.2	LOWERING THE LIFT:	17
9	FINAL CHECK OF ASSEMBLED LIFT	19
10	OPERATION TEST WITH VEHICLE	19
11	RECOMMENDED MAINTENANCE:	20
12	PARTS MANUAL	22
12.1	12,000 LB SPACE SAVER ALIGNMENT	22
12.2	SPACE SAVER ALIGNMENT MAIN FRAME ASSEMBLY - PART LIST	23
12.3	12,000 LB SPACE SAVER SERVICE & RUST PROOFER	25
12.4	SPACE SAVER MAIN FRAME ASSEMBLY, SERVICE & RUST PROOFER	26
12.5	12,000 LB SPACE SAVER OPTIONS	27
12.6	SPACE SAVER - OPTIONS PART LIST	28
12.7	12,000 LB SPACE SAVER HYDRAULICS	29
12.8	SPACE SAVER - HYDRAULICS PART LIST	30
12.9	12,000 LB SPACE SAVER POWER PACK	31
12.10	12,000 LB SPACE SAVER POWER PACK - PARTS LIST	32

1 IMPORTANT SAFETY INSTRUCTIONS

When using this lift, basic safety precautions should always be followed, including the following:



1. Read all instructions in this manual and on the lift thoroughly before installing, operating, servicing or maintaining the lift.
2. Inspect lift daily. Do not operate if it malfunctions or problems have been encountered.
3. Never attempt to overload the lift. The manufacturer's rated capacity is shown on the identification label on the power side column. Do not override the operating controls or the safety devices.
4. Only trained and authorized personnel should operate the lift. Do not allow customers or bystanders to operate the lift or be in the lift area.



5. **CAUTION! Never work under the lift unless the mechanical safety locks are engaged.**
6. Always keep the lift area free of obstruction and debris. Grease and oil spills should always be cleaned up immediately.
7. Never raise vehicle with passengers inside.
8. Before lowering check area for any obstructions.
9. To protect against the risk of fire, do not operate lift in the vicinity of open containers of flammable liquids.
10. Adequate ventilation should be provided when working on internal combustion engines.
11. Never open hydraulic lines under pressure.

SAVE THESE INSTRUCTIONS

Installation shall be performed in accordance with ANSO/ALI ALIS, Safety Requirements for Installation and Service of Automotive Lifts.

For additional safety instructions regarding lifting, lift types, warning labels, preparing to lift, vehicle spotting, vehicle lifting, maintaining load stability, emergency procedures, vehicle lowering, lift limitations, lift maintenance, good shop practices, installation, operator training and owner/employer responsibilities, please refer to “Lifting It Right” (ALI/SM) and “Safety Tips” (ALI/ST).

For additional instruction on general requirements for lift operation, please refer to “Automotive Lift-Safety Requirements For Operation, Inspection and Maintenance” (ANSI/ALI ALOIM).



ATTENTION! This lift is intended for indoor installation only. It is prohibited to install this product outdoors. Operating environment temperature range should be 41 – 104 °F (5 – 40 °C). Failure to adhere will result in decertification, loss of warranty, and possible damage to the equipment.

+ 070126-Quadra-WLSIA01

SAFETY INSTRUCTIONS

If attachments, accessories or configuration modifying components that are located in the load path, affect operation of the lift, affect the lift electrical listing or affect intended vehicle accommodation are used on this lift and, if they are not certified for use on this lift, then the certification of this lift shall become null and void. Contact the participant for information pertaining to certified attachments, accessories or configuration modifying components.

www.autolift.org

©2007 by ALI, Inc.

ALI / WLSIA01

2 SAFETY WARNING DECALS

Be sure the operator is aware and understands all safety warning labels and follows them accordingly.

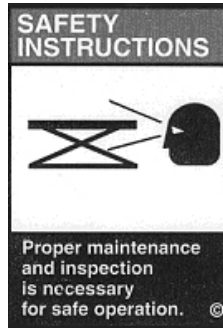

SPACE SAVER 12000 SERIES

3 SPECIFICATIONS

Maximum Capacity:	12,000 lbs.	5450 kg
Overall Width:	92 inches	2337 mm
Width Between Runways:	36 inches	914 mm
Overall Length (172"W/B):	262-15/16 inches	6680 mm
Max. Wheel base Alignment Model	172 inches	4368.8 mm
Max. Wheel base Service Model	182 inches	4622.8 mm
Max. Raised Height:	72 inches	1829 mm
Min. Lowered Height:	8-3/4 inches	222 mm
Lifting Time:	60 Sec.	
Power Requirements (Standard):	230 Volts, 1Ph., 60Hz.	
Shipping Weight ALIGNMENT Model	4980 lbs.	1615 kg
Shipping Weight SERVICE Model	4750 lbs.	2154.56 kg

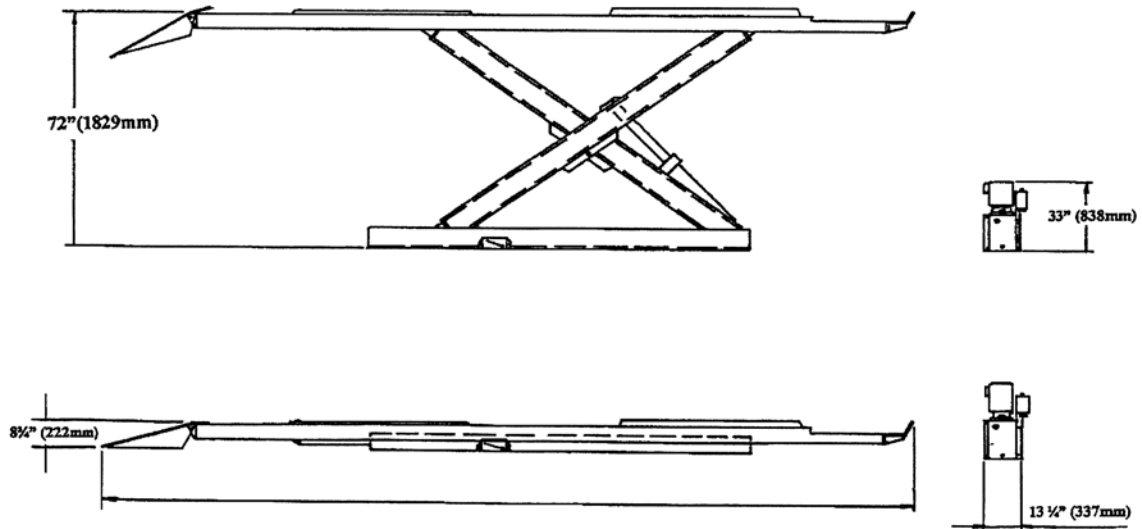

NOTE: ALIGNMENT MODEL SHOWN

Figure 1. Lift dimensions

4 CONTENTS

CHECK CONTENTS OF ACCESSORY BOX WITH PACKING LIST ENCLOSED IN BOX.

The complete lift is contained in two (2) packages:

1. The **main structural components** are pre-assembled and packaged one on top of the other.
2. The remaining parts are packed in an **accessory box**.

Main Structural Components:

- 1pc. - Left Side Main Frame Assembly; Runway, Scissors and Base Frame
 - 1pc. - Right Side Main Frame Assembly; Runway, Scissors and Base Frame
- Note:** Hydraulic lines in base frames have been factory installed

Other Contents include:

- 1pc. – Console and accessory box. (See accessory box list for contents)
- 1pc. – Customer care kit including manuals
(Refer to list provided in accessories box.)

5 TOOLS REQUIRED FOR INSTALLATION

- * Rotary Hammer Drill or Similar, ¼" and ½" Concrete Drill Bits
- * 4' Level
- * SAE Wrenches and Sockets
- * Hammer (for anchor installation)
- * Pry Bar (for shim installation)
- * Chalk Line (for lift location)
- * Tape Measure
- * Side Cutters (to cut shipping straps)
- * Screw Drivers
- * Tube bender
- * Tube cutter
- * Flaring Tool (single flare) 37° JIC
- * Hydraulic Fluid ISO 32 (10 weight hydraulic oil) - (20 liters / 5.3Gal.)
- * 25' hose ¼" hydraulic hose, 3/8" JIC female fitting each end

6 INSTALLATION INSTRUCTIONS

When the lift arrives on site, please read the owner's manual completely. Check the contents to make sure no parts are missing before starting installation. Gather all the tools listed and make sure the installation instructions are fully understood before commencing with the installation.

IMPORTANT: It is the user's responsibility to provide a satisfactory installation area for the lift. Lifts should only be installed on level concrete floors with a minimum thickness of

five (5) inches or 130 mm. Concrete must have a minimum strength of 4000 psi or 30 MPa and should be aged thirty (30) days prior to installation. Please consult the architect, contractor or engineer if doubt exists as to the strength and feasibility of the floor to enable proper lift installation and operation.

It is the user's responsibility to provide all wiring for electrical hook-up prior to installation and to insure that the electrical installation conforms to local building codes. Where required, it is the user's responsibility to provide an electrical isolation switch located in close proximity to the lift that will enable emergency stop capability and isolate electrical power from the lift for any servicing requirements.

6.1 BAY LAYOUT

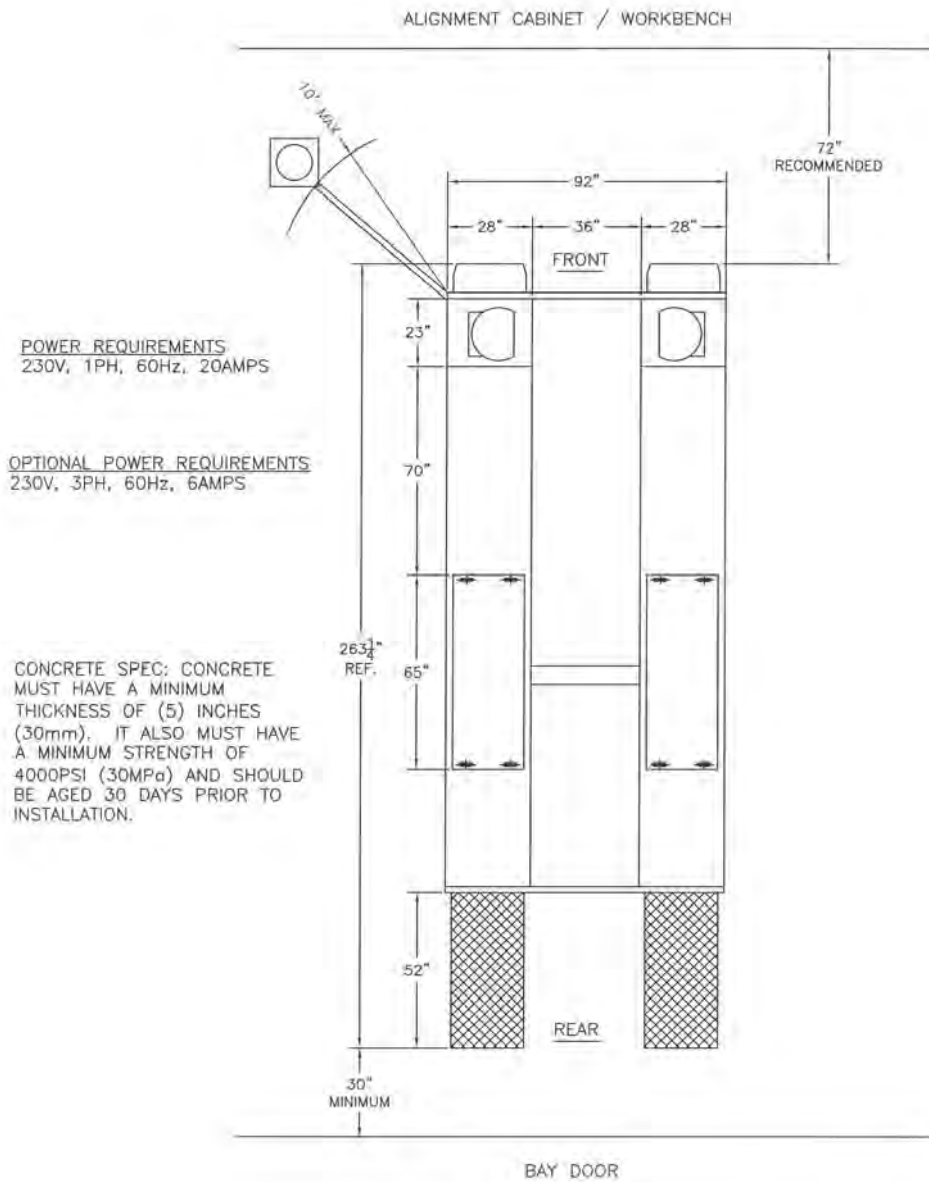

Figure 2. Typical bay layout

NOTE: Leave any additional room for any desired aisle or work area. Recommended clearance around the lift is a minimum of three (3) feet. Ensure clearance conforms to local building and fire codes.

Recommended overhead clearance is a minimum of twelve (12) foot ceiling providing 6 feet for the maximum lift height and 6 feet for the supported vehicle. For vehicles taller than 6 feet it is recommended that the user provides additional overhead clearance or a shut off mechanism to stop the lift from raising the vehicle too high.

IMPORTANT: DO NOT UNBOLT SHIPPING CLAMPS HOLDING EACH MAIN FRAME ASSEMBLY TOGETHER UNTIL INSTRUCTED TO DO SO.

1. After selecting the location best suited for your lift, draw a line parallel to the front of the lift, approximately 72" (1829mm) back from the cabinet/work bench area. This will be the approximate location of the front of the lift. Refer to **Figure 2**.

NOTE: Check the installation area for obstructions. (Overhead; light fixtures, heating ducts, ceiling, and In-ground; floor drains, electrical, etc...)

2. Mark on the floor an outline matching the dimensions listed.

SPACE SAVER - Alignment Model 12005: 172 inches (4369 mm) Wheel Base. 202 inches (5130.8mm) x 92 inches (2336.8 mm).

12000 SERIES - Service Model 12006: 172 inches (4369mm) Wheel Base. 202 inches (5130.8 mm) x 92 inches (2336.8 mm).

3. Draw a center line down the middle of the outline starting at the front of the lift location and ending at the rear approach ramps.
4. Draw two lines parallel to the center line 20" (508mm) 12,000 lb., on either side to locate the inside of the baseframes.
5. Draw a line parallel to the front of the lift or pit (flushmount) and align the front of each base frame assembly onto this line.
172" (4369 mm) w/b: 38" (965.2 mm) back from the front of the lift.
6. Check the floor in the outline for the highest point using a four (4) foot level. Mark this location, reference will be made to it later during the levelling procedure.

6.2 UNPACKING PROCEDURE

1. Cut and remove the metal banding straps that hold the accessory box (and sliding Jack Beams if so equipped) and place in a convenient location near the installation area.
2. Cut and remove the metal banding straps surrounding the Two Main Frame Assemblies. Position the Main Frame Assemblies in the location previously marked in the bay layout.

NOTE: To distinguish between the left and right Main Frame Assemblies the pull-out step should be located at the front facing outward from the lift. All measurements are to be taken from the front of the lift.

3. Check that the inside of the base frames are 20" (508mm) away from the center line at both the front and rear of each mainframe assembly and that the front of each base frame is on the line drawn in step 5 of the bay layout, section 4.1.

6.3 HYDRAULIC INSTALLATION

NOTE: When working with hydraulics it is important to keep all components clean. All hydraulic connections are 37 ½° JIC flares.

1. Select a position best suited for the power pack.
2. Remove the breather filler cap and fill with 20liters/5.3Gal. of ISO 32 hydraulic fluid.
3. Using a hydraulic tube bender, run a hydraulic line from the power pack to the hydraulic inlet fitting located on the left side of the left base frame. After all the lines are cut and formed, install the nuts and sleeves, and then flare the ends of the tube.
4. If you have purchased the factory air kit option you should now cut and form the air supply line, from the lift to the desired location for customer connection to their shop air supply. **The air supply line should have an operating pressure of 90-120psi (6-8 bar).**
5. Tighten all the supply lines. You may now anchor the hydraulic power pack. (floor or wall mount).
6. Connect one end of the center hydraulic line to the outlet side of the left main frame assembly and the other end to the inlet side of the right main frame assembly. Tighten the hydraulic line in place so that it runs along the floor giving it a low profile.

IMPORTANT: THE SHIPPING CLAMPS HOLDING EACH MAIN FRAME ASSEMBLY TOGETHER MUST BE UNBOLTED BEFORE CONNECTING ELECTRICAL POWER. THERE ARE TWO (2) CLAMPS ON EACH ASSEMBLY.

6.4 ELECTRICAL INSTALLATION

IMPORTANT: ALL FINAL ELECTRICAL CONNECTIONS SHOULD BE MADE BY A QUALIFIED ELECTRICIAN.

Please refer to **Figure 3**, the electrical diagram. Select a position for the remote hand control pendant to be hung from the ceiling. Hang in a position so the safety pedal may be easily reached.

**NOTE: THE CONTROL PENDANT SHALL BE INSTALLED IN SUCH A MANNER THAT THE CONTROL PENDANT CANNOT ENTER THE 18" HIGH LEVEL ABOVE THE FLOOR.
(CLASS 1, DIVISION 2, HAZARDOUS LOCATIONS)**

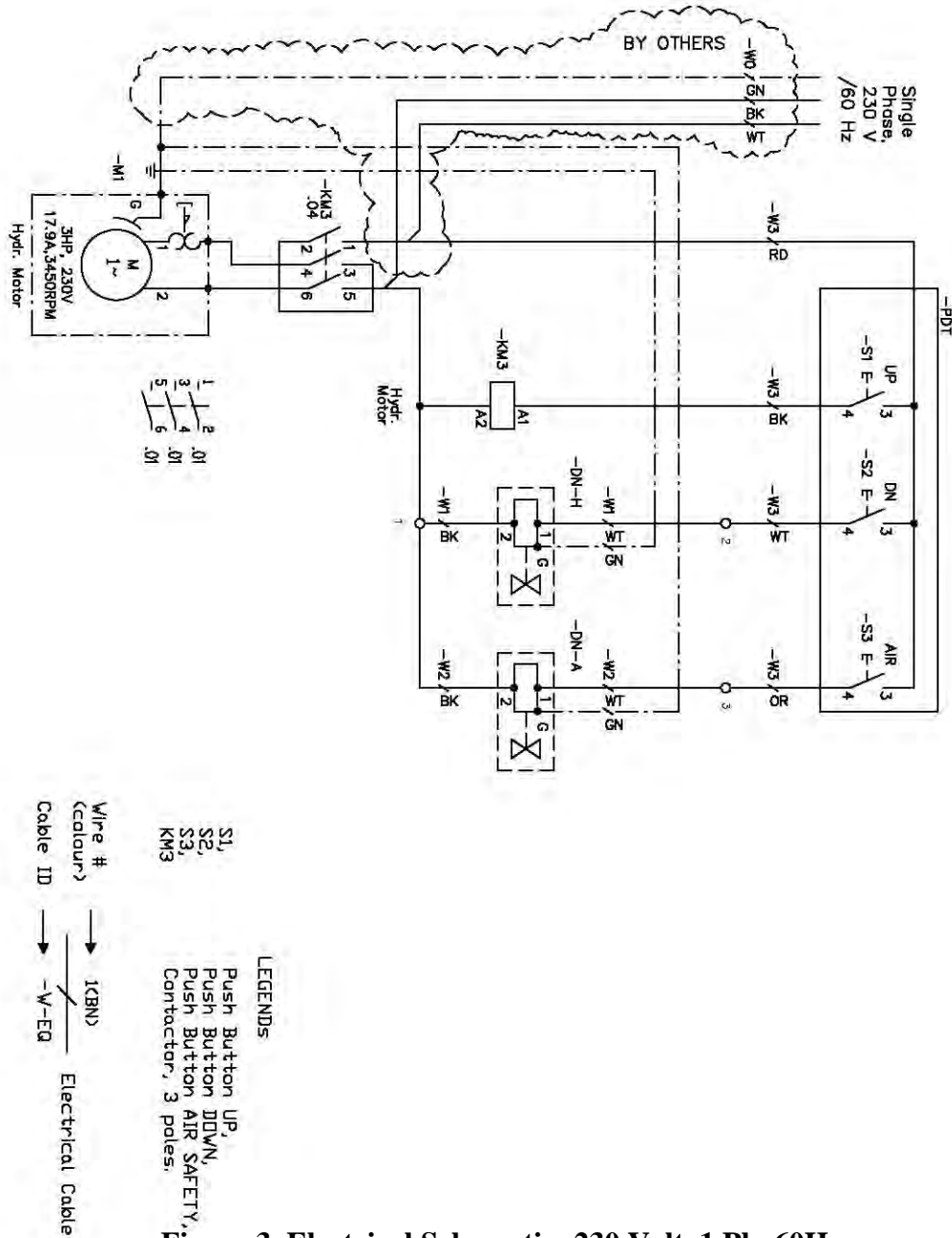

Figure 3. Electrical Schematic; 230 Volt, 1 Ph. 60Hz

NOTE: Optional voltage and phase type power units will come with their own wiring diagram.

IMPORTANT: WITH THE MAIN ELECTRICAL SUPPLY CONNECTED, PRESS THE UP CONTROL BUTTON TO RAISE THE LIFT 10" (254mm). STOP, THEN PRESS THE DOWN CONTROL BUTTON TO LOWER THE LIFT. REPEAT THIS PROCEDURE THREE (3) TIMES TO RELIEVE AIR FROM THE HYDRAULIC SYSTEM. CHECK FOR HYDRAULIC LEAKS AT ALL CONNECTIONS.

6.5 MECHANICAL SAFETY INSTALLATION

1. Locate the two (2) mechanical safety release rods and one (1) mechanical safety release connecting rod.
2. Raise the lift by pressing the up button on the hand control.
3. **Turn off the power supply to the power pack.**
4. Slide each mechanical safety release rod through the holes closest to the rear of each baseframe.
5. Slot in end of the bar should be parallel to the ground when center cut-out points up towards the front. Refer to **Figure 4**.

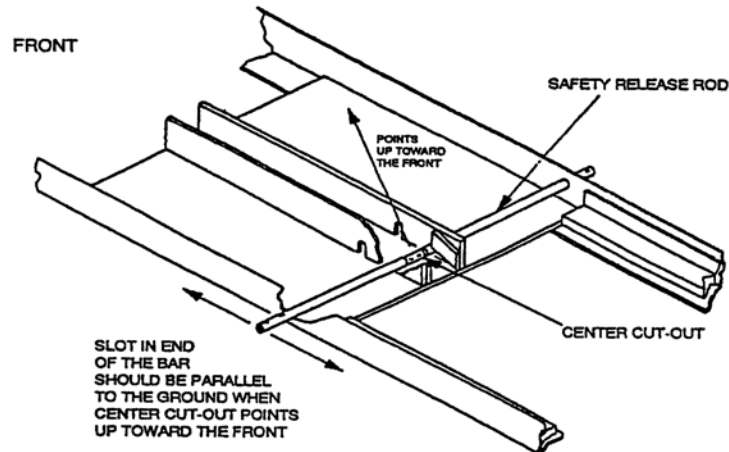

Figure 4. Safety release rod location

6. Install the rectangular safety release tab using 2 ¼" - 20UNC x ¾" long hex bolts and lock washers. The safety release tab bolts to the flat surface of the safety release rod located under the mechanical safety locking bar.
7. Install foot pedals one on the outside of each safety release rod, using for each pedal 2; ¼" - 20UNC x 1¼" long hex bolts, nuts, and lock washers.
8. Install pedal safety guards. One on each baseframe using the ¼" - 20UNC x ¾" long hex bolts, nuts, and lock washers.
9. Install the safety release connecting rod between the safety release rods, using 2; ¼" - 20 UNC x 1¼" long hex bolt, nut and lock washers one on each end of the rod.
10. Tighten all installation hardware.
11. Place the mechanical safety locking bars back in their engaging positions.
Turn power back on.
12. **FOR THOSE UNITS EQUIPPED WITH SLIDING JACK BEAMS NOW IS THE TIME TO INSTALL THE JACK.** Lower lift and consult instructions supplied with each Jacking Beam.
13. Turn on the shop air supply and check for leaks. The air supply line should have an operating pressure of 90-120psi (6-8bar).

6.6 FRONT AND REAR TIE BAR INSTALLATION

1. Raise lift to working height and lower onto safety.
2. Have 2; ½”-13UNC x 1½” long hex head bolts, flatwashers, lockwashers and nuts ready to support the tie bar when it is raised into place.
3. Raise the rear tie bar into place making sure the slotted holes are up and the nose-like protrusions are pointing toward the front of the units. The vertical members on the tube should be on the outside of the deck skirts. Line up each vertical section slot with the respective slot on the deck and place the bolts with washers through, one on each side. Put the flatwashers and lockwashers and nuts on the inside of the decks.
DO NOT TIGHTEN!
4. Install 2; ½”-13UNC x 1½” long hex bolts, flatwashers and lockwashers to each end of the tie bar positioned under the deck. **DO NOT TIGHTEN!**
5. Now install the remaining 6; ½”-13UNC x 1½” long hex bolts, flatwashers, and lockwashers to the tie bar. **DO NOT TIGHTEN!** Baseframes should be level before tightening, Refer to leveling procedure (following section).

6.7 LEVELLING PROCEDURE

NOTE: This is a very important procedure and time must be taken to do it correctly.

1. The highest point on the floor, noted from Section 4.1 step 6 is the point from which the base frame will be levelled from. A quick check using a four (4) foot level across the base frame should again verify that this is the highest point.
2. Starting at the corner closest to the highest point, check along the length of the base frame edge with the four foot level and shim as required. **NOTE THE FIVE CRITICAL POSITIONS THAT SHIMS MUST BE PLACED ON EACH BASE FRAME OF EACH MAIN FRAME ASSEMBLY.** Refer to **Figure 5**.
3. Continue shimming across that base frame from side to side, and front to rear.
4. After levelling one frame completely, level the inside rails of the base frames to one another.
5. Now level the remaining outside half of the last base frame by placing the level across that unit and shimming as required.
6. A quick check across, along and between each base frame will ensure the levelling procedure was carried out successfully. Re-adjust the tie bars if necessary.
7. Raise and lower the hoist completely several times. This allows the hoist to settle and will ensure its proper operation.

LEVELLING EXAMPLE: FIGURE 5

Assuming that the front right corner is the highest point level in the following order:

- Shim along side "A"
- Shim across from side "A" to side "B" (check along side "B" from front to back)

The Right Side base frame should now be levelled.

- Shim across from side "B" to side "C" (check along side "C" from front to back)
- Shim across from side "C" to side "D" (check along side "D" from front to back)
- Shim along side E & side F (locking Mechanism)

Both base frames should now be levelled from front to back and side to side.

NOTE: Base frame levelling should be performed as a reference before main levelling of the decks. One last check before anchoring is to make sure that there is 36" between the baseframes.

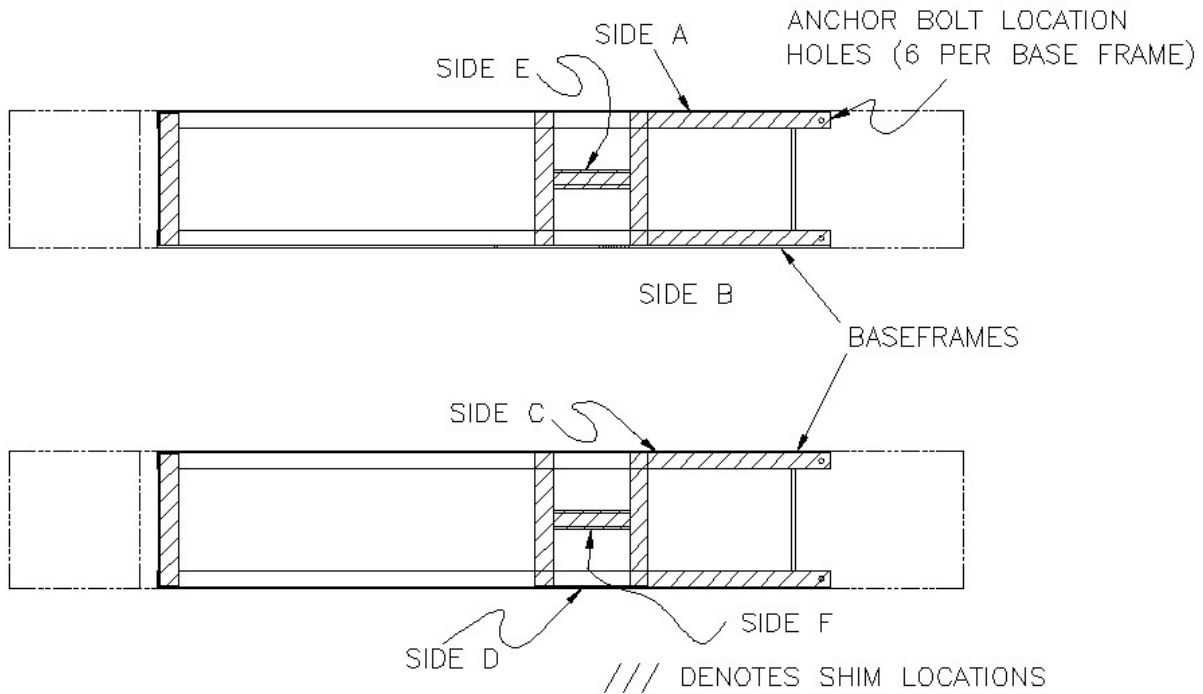

Figure 5. Levelling procedure example

6.8 ANCHORING PROCEDURE:

1. Raise the lift to full height and repeat the measurements, and ensure there are no differences.
2. Using a rotary hammer drill and a 1/2" concrete bit, drill through the floor at each of the six (6) anchor bolt locations on each of the base frames. Make sure that the 1/2" concrete drill bit is in good condition. Refer to **Figure 6**.
3. Assemble the nut and washer onto the 1/2" x 4 1/2" long wedge anchor bolts supplied. A minimum of six threads must be visible below the surface of the nut.
4. Clean out the drilling dust from the holes and hammer in the anchors until they make contact with the baseplate. **Hand tighten all anchor bolts.**
5. Torque all anchor bolts to 55 ft-lbs.
6. Position the console in the final desired location. Using a rotary hammer drill and a 1/4" concrete bit, drill and anchor the console to the floor using the Nail in Anchors located in the hardware kit.
7. Use the line covers to protect all cables, hoses, and wiring running to the lift. Using a rotary hammer drill and a 1/4" concrete bit, drill and anchor the line covers using the nail in anchors located in the hardware kit.
8. With all anchor bolts torqued as specified operate the lift checking its full operation.

If anchor bolts do not tighten to 55 ft-lbs. OR project more than 2 1/4" above the concrete surface, the concrete should be replaced by an appropriate concrete pad. (Consult Product Manufacturer / Supplier for further details)

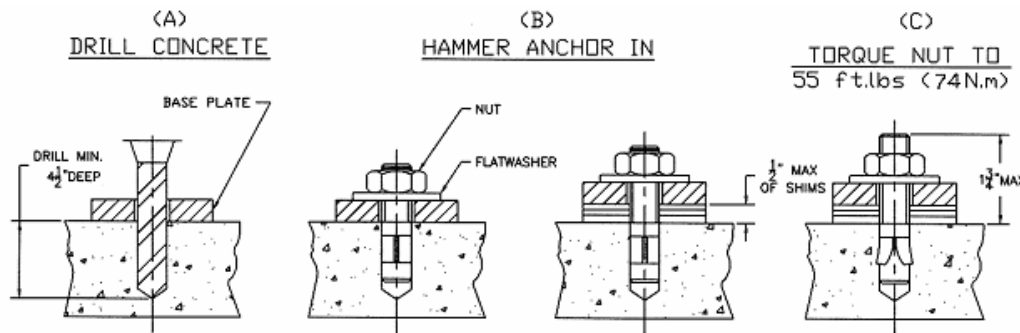

Figure 6. Anchoring

6.9 INSTALLATION FOR ALIGNMENT MODEL

1. Locate and install two (2) front wheel stops; one (1) to the front of each of the runways using six long hex head bolts, flat washers, lock washers, and nuts.

NOTE: The lift has a front tie bar that must be installed before the front wheel stops are installed.

2. Unpack the levelling legs as marked on the leg and mounting hardware and place in their respective locations. **NOTE:** On the alignment model the REAR levelling legs fold up toward the rear. The FRONT levelling legs towards the front.
3. Position but do not tighten all levelling leg brackets. The levelling legs should hang in the brackets and swing freely. Thrust washers are provided to take up any side play in

legs, install if required. Install thrust washers if there is more than 1/8"(3mm) clearance.

4. Check that legs hang perpendicular to the ground BEFORE tightening leg bracket bolts.
5. Lower the Space Saver lift down onto the levelling legs.
6. Check and adjust the decks for level using the 4' level. Adjusting screw and jam nuts should be adjusted until each corner of lift is level. Make sure jam nuts are tightened after levelling. Both the front turn plate cutouts and rear slip plates should be checked. Refer to **Figure 7**.

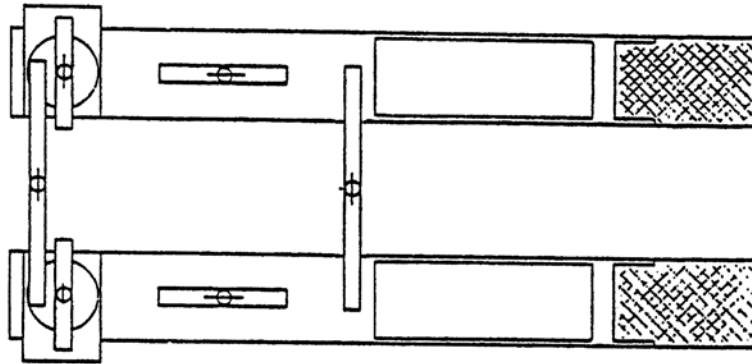

Figure 7. Deck levelling

6.10 INSTALLATION FOR ALL MODELS

1. Locate and install the center cover over the mechanical safety release connecting rod and hydraulic line. Install using four (4), 1/4" - 20 UNC x 3/4" long hex head bolts, flat washers and lock washers.
2. Check to make sure that the safety release connecting rod does not rub or bind during operation.
3. Locate and install protective line covers over all air and hydraulic supply lines on the left side base frame of the left main frame assembly.
4. Using a rotary hammer drill and a 1/4" concrete drill bit, drill all line cover locations. Using the 1/4" concrete nails supplied fasten the line covers to the floor.
5. Install the approach ramps using ramp pins, washers, and cotter pins.
6. **Tighten** all bolts on crossmember(s).

7 INSTALLATION OF 6000 LB. JACKING BEAM (SERIES 206 & 216)

1. Remove jacking beam from shipping carton. Remove the keeper brackets. Place the Jack Beam on the Space Saver hoist making sure the roller wheels are centered on the jacking beam track.
2. Raise the Space Saver hoist to a comfortable working height. Re-install the keeper brackets located under the jacking beam.
3. Connect coiled air hoses supplied to the air inlet on the power pack for permanent installation. Install ¼ NPT plugs or compatible air fitting to work with shop air tools to the extra outlets provided at the front and rear of the hoist.
4. Store the risers in holding brackets located on the top of the jacking beam.
5. All personnel operating the Space Saver jacking beam must be fully trained on its operation as described by manufacturer.

8 OPERATING INSTRUCTIONS:

8.1 RAISING THE LIFT:

1. If the lift is equipped with Sliding Jack Beam(s) be sure that the Beam(s) are positioned at the front or mid travel of the lift, fully down, with the risers removed and stored. Never store Jack Beam(s) at the rear of the lift.
2. Be sure that the lift is fully lowered before attempting to load or unload a vehicle.
3. Position the vehicle on the lift ensuring the resulting load on each runway is as equal as possible. Under no circumstances should a vehicle be lifted if the weight distribution is unbalanced by 10% on either side of the center line between the runway.

NOTE: The vehicle is positioned correctly when the distance from the center of the tires to the inside edge of the runways is equal on both runways, for the front and rear tires.

4. Check that there are no obstructions above the lift that could damage the lift or vehicles.
5. Raise the lift by pressing the up button on the remote pendant control. Raise the lift up, continue to raise, past the desired working height until the mechanical safety drops into position. Stop raising, now press the down button to lower the lift down onto both of the mechanical safeties.

NOTE: NEVER WORK UNDER A VEHICLE OR THE LIFT UNLESS IT IS POSITIONED ON BOTH MECHANICAL SAFETIES!!!

8.2 LOWERING THE LIFT:

1. Check that there are no obstructions under the lift or vehicle. Be sure that the Sliding Jack Beams are fully lowered and positioned at the front or mid section of the lift.
2. Raise the lift by pressing the up button until the mechanical safety bars are off of their stops. Stop raising.
3. Depress the safety release pedal to disengage the mechanical safety locking bars. Continue to hold the pedal depressing the down button on the remote pendant control.
4. Continue lowering until the lift is approximately 34" (864mm) above the floor. Then release the mechanical safety release pedal, allowing the mechanical safety locking bars to be readied for their next use. Continue to depress the down button until the lift is completely lowered.

NOTE: The operator must always keep their attention on the operation of the lift while raising or lowering.

5. Be sure that the lift is completely lowered before removing the vehicle from the lift.

9 FINAL CHECK OF ASSEMBLED LIFT

1. Final dimension check after anchoring. _____
2. Check for hydraulic leaks. _____
3. Re-check level of decks, front to rear, side to side. _____
4. Check torque of anchor bolts. _____
5. Check all fasteners, tighten if necessary. _____
6. Operate lift to full stroke then lower to ground while checking for proper functionality. _____
7. Ensure Customer Care Kit is complete and given to operator. _____
 - a. Operation Manual _____
 - b. ANSI / ALI Lift It Right Manual _____
 - c. ANSI / ALI Safety Tip Card _____
 - d. ANSI / ALI ALIS Safety Requirements for Installation and Service of Automotive Lifts _____
 - e. ANSI / ALI Quick Reference Guide _____
8. Train end user on operation of lift. _____

10 OPERATION TEST WITH VEHICLE

1. Lower lift to ground.
2. Drive vehicle on to lift.
3. Raise lift to and lower onto 3-4 lock positions during full rise to ensure all locks are working correctly.
4. Check lowering speed and smooth decent rate.
5. Lower lift to ground and drive vehicle off lift.

If any problems occur during the final checkout or operation of the lift please contact customer service at 1-800-268-7959

11 RECOMMENDED MAINTENANCE:

1. Adjust level of lift daily.
2. The lift should be greased at least once every two months. There are six (6) points on each lift that will take grease: four (4) on the scissors hinges and one on each of the two (2) hydraulic cylinder rod eyelet's.
3. The fluid level in the reservoir should be checked periodically. Be sure that the lift is fully lowered when checking. The hydraulic fluids should be changed once every five years. Use only ISO 32 hydraulic fluid.
4. The roller tracks should always be kept clean and free of debris. This area should be checked before any raising or lowering of the lift.
5. Inspect the operation of the lift daily. Raise and lower fully.
6. Inspect electrical and mechanical operations of all switches, electrical and mechanical.
7. Lifts equipped with full floating rear slip plates and front radius turning plates, require to be disassembled and cleaned once every 3 months. More frequently with lifts that are in areas with more exposure to sand and salt.

NOTE: Locking pins should always be installed on front and rear plates before attempting to drive a vehicle on or off the lift.

8. If uneven lifting occurs as described in section 6.1.3 the crossmember(s) will need to be re-adjusted.

DO NOT ATEMPT TO LIFT A VEHICLE EXCEEDING THE LIFT'S RATED LIFT CAPACITY OF 12,000 LBS.

QUARTELY REAR SLIP PLATE MAINTENANCE

1. Remove top Slip Plate covers by first removing the four (4) shoulder bolts on each cover.
2. Remove polyethylene bearing cages insuring that all the delrin bearings remain in the cages. Additional delrin bearings may be purchased if required.
3. Clean runway surface and touch up any paint wear with a rust resistant paint. Allow paint to dry thoroughly.
4. To obtain optimum performance, the position of the slip plate bearing cage should be rotated every quarter to change the wear pattern. With the first quarter maintenance, flip the bearing cage over to the opposite side. With the second quarter maintenance, rotate

the bearing cage end-to-end. With the third quarter maintenance, flip bearing cage over to the opposite side. Fourth quarter maintenance should see the bearing cage rotated back to the position it started in.

5. Quarterly maintenance will optimize performance and contribute to longer slip plate life.

12 PARTS MANUAL

12.1 12,000 LB SPACE SAVER ALIGNMENT

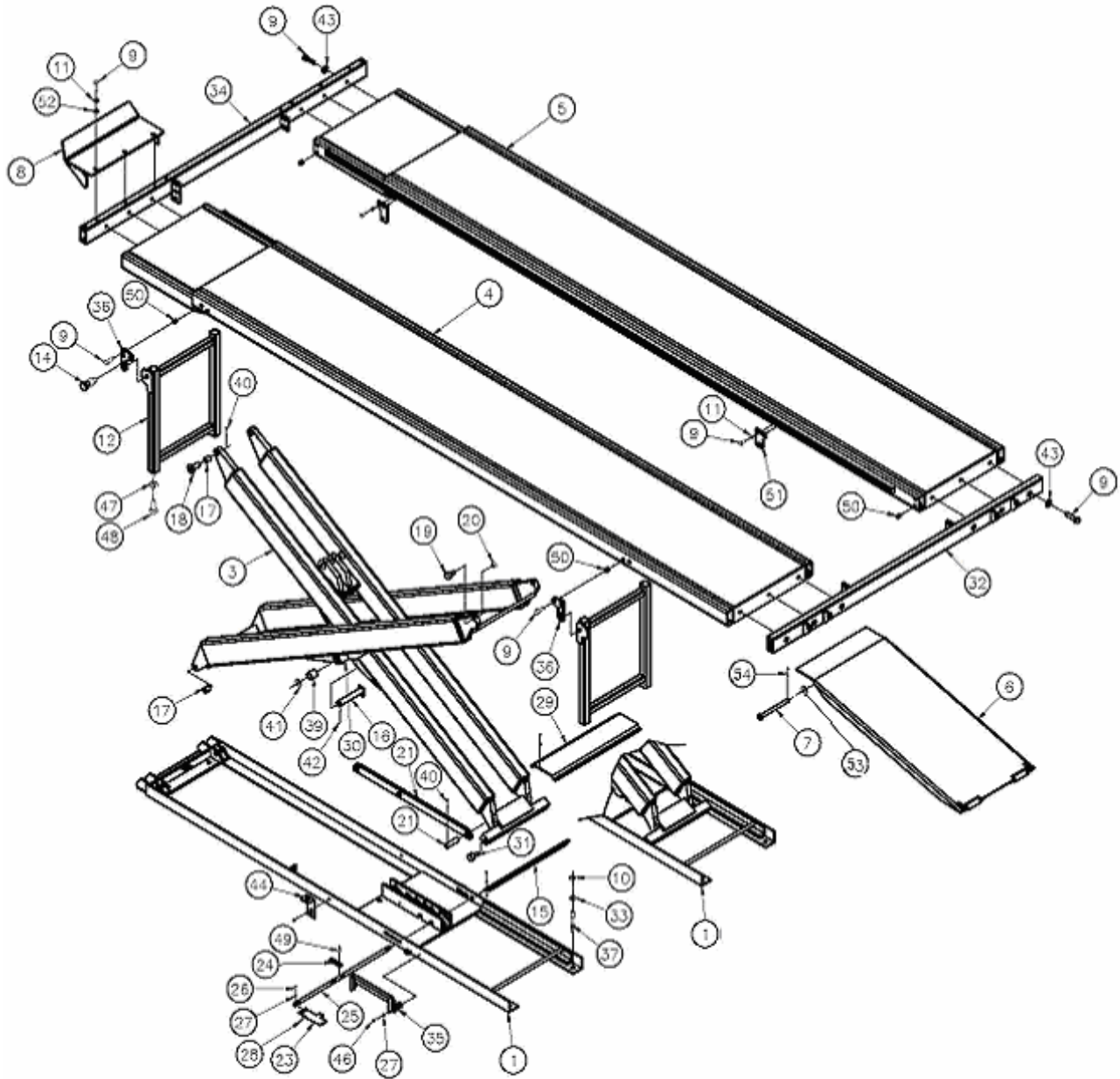

12.2 SPACE SAVER ALIGNMENT MAIN FRAME ASSEMBLY - PART LIST

ITEM #	QTY.	DESCRIPTION	PART
1	2	BASE FRAME WELDMENT	4-0160
3	2	SCISSOR WELDMENT	4-0153
4	1	ALIGNMENT DECK, LEFT SIDE (172"W/B)	4-0158
5	1	ALIGNMENT DECK, RIGHT SIDE (172"W/B)	4-0159
6	2	RAMP ASSEMBLY W/ROLLER (172"W/B)	3-0905
7	4	APPROACH RAMP PIN	1-1887
8	2	FRONT WHEEL STOP	2-0998
9	38	HEX BOLT, ½" - 13UNC X 1 ½"LG.	6-0291
10	32	HEX NUT, ½" - 13UNC	6-0035
11	38	LOCK WASHER, ½" I.D.	6-0059
12	2	LEVELLING LEG, FRONT-LEFT, REAR-RIGHT	3-0300
13	2	LEVELLING LEG, FRONT-RIGHT, REAR-LEFT	3-0299
14	4	PLUNGER PIN ASSEMBLY	2-0086
15	1	SAFETY RELEASE CONNECTING ROD	2-0071
16	4	FULCRUM PIN, 1 ¼" DIA.	1-0106
17	8	BUSHING, 1" I.D.	6-0630
18	8	END HINGE PIN, 1" DIA.	1-0107
19	4	CAM FOLLOWER, UPPER	6-0076
20	4	JAM NUT, 5/8" - 18UNF	6-0040
21	2	SAFETY BAR WELDMENT	2-1683
22	2	SAFETY PIN	1-0547
23	2	SAFETY PEDAL	2-0742
24	1	SAFETY RELEASE TAB	1-2169
25	1	SAFETY RELEASE ROD	2-2134
26	6	HEX BOLT, ¼" - 20UNC X 1 ¼"LG.	6-0027
27	14	LOCK WASHER, ¼" I.D.	6-0056
28	6	HEX NUT, ¼" - 20UNC	6-0032
29	1	CENTER COVER	3-0164
30	4	GREASE NIPPLE	6-0000
31	4	CAM FOLLOWER, LOWER	6-0077
32	1	REAR CROSSMEMBER WELDMENT	3-0297
33	16	FLAT WASHER, ½" I.D.	6-0439
34	1	FRONT CROSSMEMBER (172" W/B)	3-0298
35	2	TOE GUARD	1-0698
36	4	LEVELING LEG BRACKET, OUTSIDE	2-0118
37	16	WEDGE ANCHOR, ½" X 4 ½" LG	6-0140
38	4	CONCRETE NAIL, ¼" X 1" LG	6-0141
39	4	BUSHING, 1 ¼" I.D.	6-0084
40	12	COTTER PIN, 1/8" X 2" LG	6-0115
41	4	WASHER	1-0140
42	4	SPRING PIN, 3/16" X 2" LG	6-0146

43	6	FLATWASHER, 1/2"	6-0439
44	4	FLAT SHIPPING BRACKET	1-0728
45	4	CAP SCREW, HEX HEAD, 1/4" – 20UNCX2 1/2" LG	6-0554
46	4	HEX BOLT, 1/4" – 20 UNC X 2 1/2" LG	6-0554
47	8	JAM NUT, 3/4" – 10UNC	6-0041
48	8	TAP BOLT, 3/4" X 4" LG	6-0050
49	4	FLAT HEAD, 1/4"-20UNC X 3/4" LG.	6-1086
50	4	LEVELING LEG BRACKET, INSIDE	1-2888
51	16	THREADED INSERT, 1/2"-13UNC	6-2432
52	6	FLAT WASHER, 1/2 I.D.	6-0063
53	4	FLAT WASHER, 3/4 I.D.	6-0978
54	4	COTTER PIN 1/8" X 1 1/2"	6-0738

12.3 12,000 LB SPACE SAVER SERVICE & RUST PROOFER

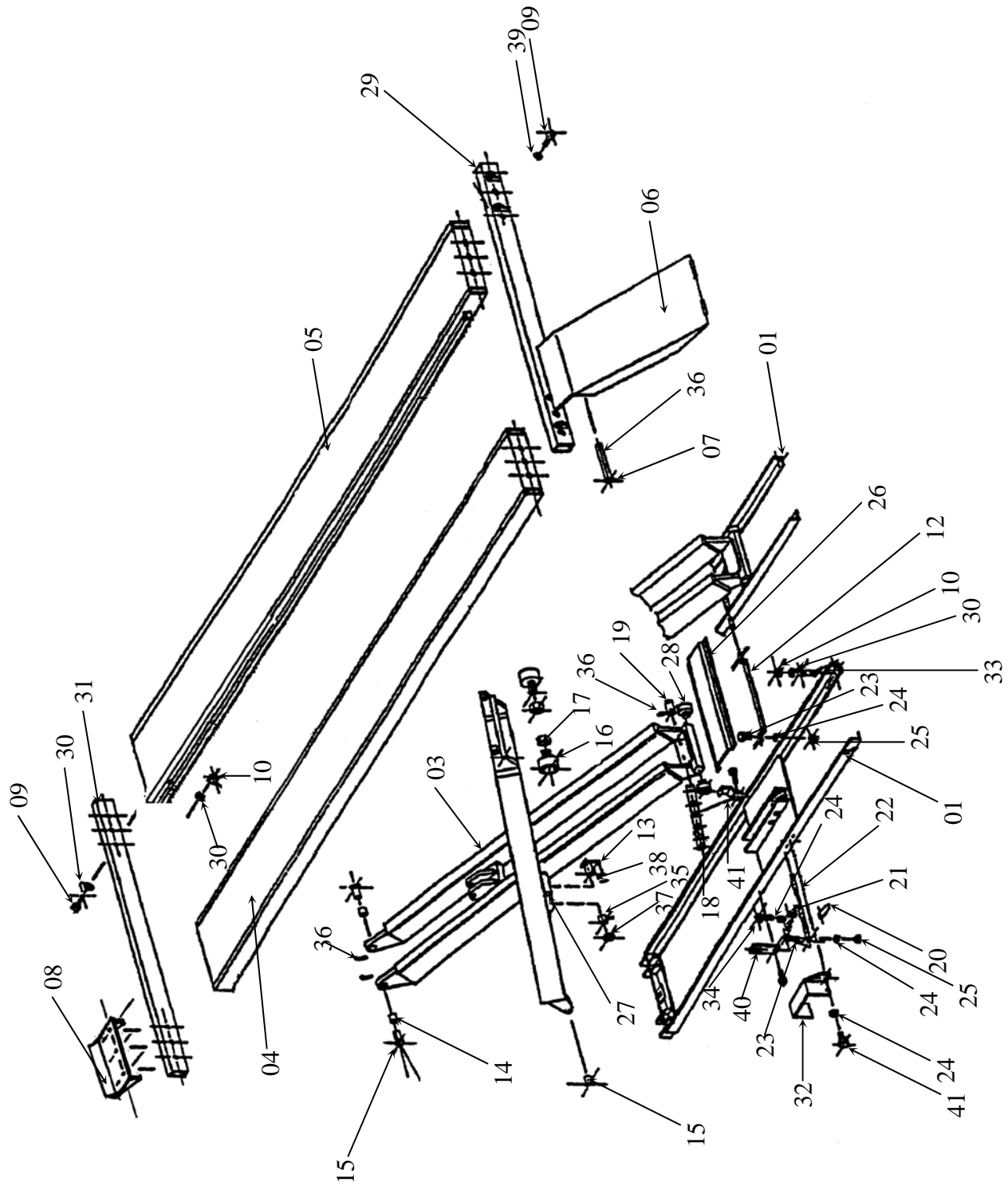

12.4 SPACE SAVER MAIN FRAME ASSEMBLY, SERVICE & RUST PROOFER

ITEM	QTY	DESCRIPTION	PART #
1	2	BASE FRAME WELDMENT	4-0160
3	2	SCISSOR WELDMENT	4-0153
4	1	SERVICE DECK, LEFT SIDE	4-0162
5	1	SERVICE DECK, RIGHT SIDE	4-0163
6	1	RAMP ASSEMBLY w/ ROLLER	3-0905
7	2	RAMP PIN	1-0095
8	2	FRONT WHEEL STOP	2-0432
9	10	HEX BOLT 1/2-13UNC X 1-1/2"LG.	6-0291
10	22	HEX NUT 1/2"-13UNC	6-0035
11	14	LOCKWASHER 1/2" ID.	6-0059
12	1	SAFETY RELEASE CONNECTING ROD	2-0071
13	4	FULCRUM PIN, 1-1/4" DIA.	1-0106
14	8	BUSHING, BRONZE, 1"ID.	6-0630
15	8	END HINGE 1" DIA.	1-0107
16	4	CAM FOLLOWER	6-0637
17	4	JAM NUT, 5/8-18UNF	6-0040
18	2	SAFETY BAR WELDMENT	2-1683
19	2	SAFETY PINS	1-0547
20	2	SAFETY PEDAL	2-0742
21	2	SAFETY RELEASE TAB	1-2169
22	2	SAFETY RELEASE ROD	2-2134
23	6	HEX BOLT, 1/4-20UNC X 1-1/4"LG.	6-0027
24	14	LOCKWASHER, 1/4"	6-0056
25	8	HEX NUT, 1/4-20UNC	6-0032
26	1	CENTRE COVER	3-0952
27	4	GREASE NIPPLE	6-0000
28	4	CAM FOLLOWER	6-0077
29	1	REAR CROSSMEMBER WELDMENT	3-0297
30	22	1/2 SAE FLAT WASHER	6-0439
31	1	FRONT CROSSMEMBER	3-0298
32	2	TOE GUARD	1-0698
33	16	WEDGE ANCHOR 1/2" X 4-1/2"LG.	6-0140
34	4	CONCRETE NAIL 1/4 X 1"LG.	6-0141
35	8	BUSHING, 1 1/4" ID	6-0084
36	14	COTTER PIN 1/8" X 2"	6-0115
37	4	WASHER	1-0140
38	4	SPRING PIN, 3/16" X 2" LG	6-0146
39	6	WASHER, FLAT, 1/2"	6-0439
40	2	FLAT SHIPPING BRACKET	1-0728
41	4	CAP SCREW, HEX HEAD, 1/4 - 20 UNC X 2 1/2" LG	6-0554

12.5 12,000 LB SPACE SAVER OPTIONS

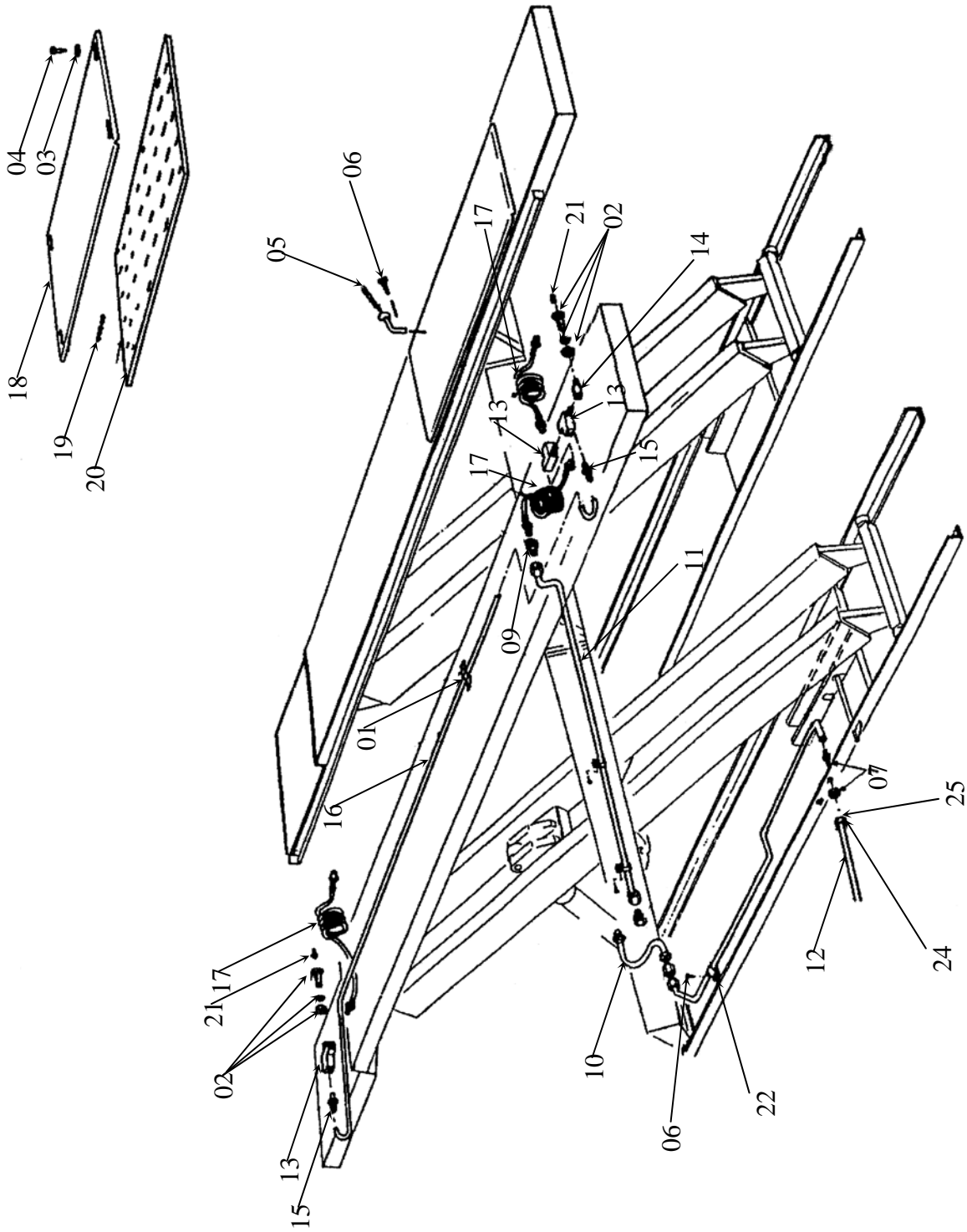

12.6 SPACE SAVER - OPTIONS PART LIST

ITEM #	QTY.	DESCRIPTION	PART
1	2	FRAME CLIP	6-0168
2	2	TERMINAL BOLT, 3/4"-16m W/1/4 NPT F	6-0167
3	8	FLAT WASHER	6-0426
4	8	SHOULDER BOLT, 3/8" X 5/8"LG.	6-0069
5	4	LOCKING PIN ASSEMBLY	2-2184
6	8	SELF TAP SCREW #10 X 3/8"LG.	6-0169
7	1	BULKHEAD, 90 DEG. ELBOW c/w JAM NUT	6-0012
8	1	TUBE ASSEMBLY	3-0017
9	1	ADAPTER, 1/4" PUSHLOCK x 3/8" JIC	6-0788
10	1	HOSE ASSEMBLY	1-0119
11	1	TUBE ASSEMBLY	2-0062
12	1	SUPPLY TUBE, 3/8" X .049" X 20'LG.	6-0171
13	3	STREET TEE 1/4"NPT	6-0014
14	1	STREET ELBOW 1/4"NPT	6-0015
15	2	HOSE BARB FITTING, 1/4" NPT 3/8" HOSE	6-0710
16	222"	POLYTUBE 3/8" OD x .062" WALL	8-0142
17	3	12' COILED HOSE	6-0337
18	2	REAR SLIP PLATE WELDMENT	3-0197
19	1 SET (225)	BALL BEARING	6-0829
20	2	REAR BEARING CAGE	3-0196
21	2	PLUG, 1/4"NPT	6-0282
22	4	TUBE CLAMP	6-0170
24	2	TUBING SLEEVE, JIC	6-0017
25	2	TUBING NUT, 3/8" JIC	6-0016

12.7 12,000 LB SPACE SAVER HYDRAULICS

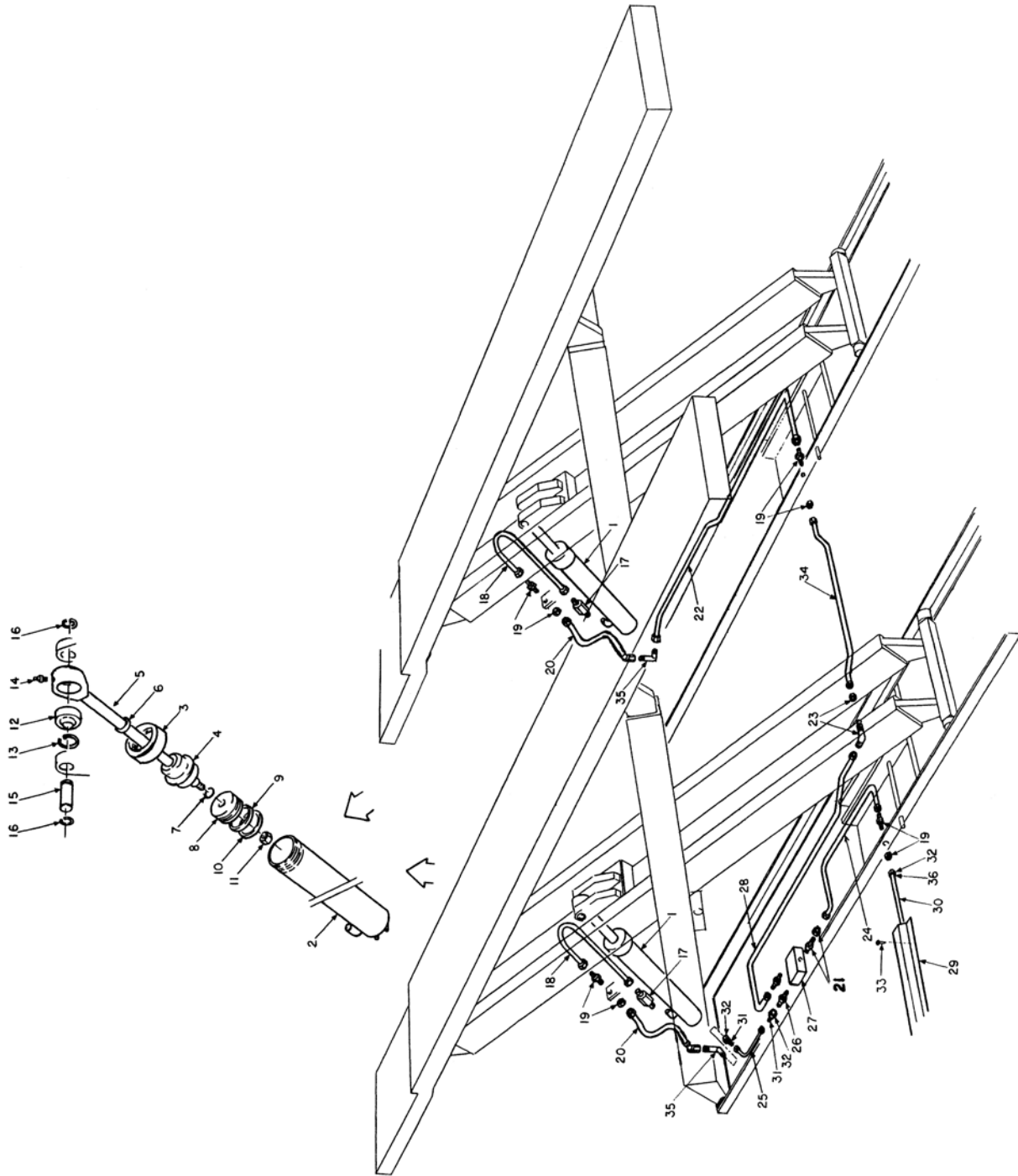

12.8 SPACE SAVER - HYDRAULICS PART LIST

ITEM #	QTY.	DESCRIPTION	PART
1	2	HYDRAULIC CYLINDER	3-0000
1-2	1	TUBE WELDMENT	2-0000
1-3	1	NUT GLAND	1-0011
1-4	1	GLAND	1-0008
1-5	1	ROD WELDMENT	2-0001
1-6*	1	WIPER RING	6-0001
1-7*	1	'O' RING	6-0002
1-8	1	PISTON	1-0007
1-9*	1	SEAL RING	6-0003
1-10*	1	WEAR RING	6-0004
1-11	1	NYLON INSERT LOCK NUT, 7/8"-14UNF	6-0005
1-12	1	BEARING	6-0007
1-13	1	RETAINING RING	6-0070
1-14	1	GREASE NIPPLE	6-0000
15	2	PIN	1-0029
16	4	RETAINING RING	6-0340
17	2	VELOCITY FUSE	6-0422
18	2	TUBE ASSEMBLY, CYLINDER	1-0093
19	4	BULKHEAD, CONNECTOR 3/8"JIC C/W JAM NUT	6-0013
20	2	HOSE ASSEMBLY	2-2136
21	1	BULKHEAD ADAPTER, 3/8"BSF TO 3/8"JIC	6-0176
22	1	TUBE ASSEMBLY, RIGHT SIDE	2-0068
23	1	BULKHEAD, 90° ELBOW 3/8"JIC M C/W JAM NUT	6-0012
24	1	TUBE ASSEMBLY	2-0064
25	1	TUBE ASSEMBLY	2-0182
26	2	ADAPTOR, 3/8"BSF TO 3/8"JIC	6-0156
27	1	FLOW DIVIDER (WITH FITTINGS)	6-0173
28	1	TUBE ASSEMBLY	2-0066
29	4	LINE COVER	2-1104
30	1	SUPPLY TUBE 3/8" X .049"WALL X 20'	6-0171
31	2	REDUCER NIPPLE, 3/8" TO 1/4"	6-0974
32	2	NUT, 3/8" TUBE	6-0016
33	16	CONCRETE NAIL, 1/4" x 1"	6-0141
34	1	TUBE ASSEMBLY	2-0519
35	2	ADAPTER, 90° EXTENDED	6-0174
36	2	SLEEVE	6-0017

*HYDRAULIC CYLINDER SEAL KIT PART # 0-0007

12.9 12,000 LB SPACE SAVER POWER PACK

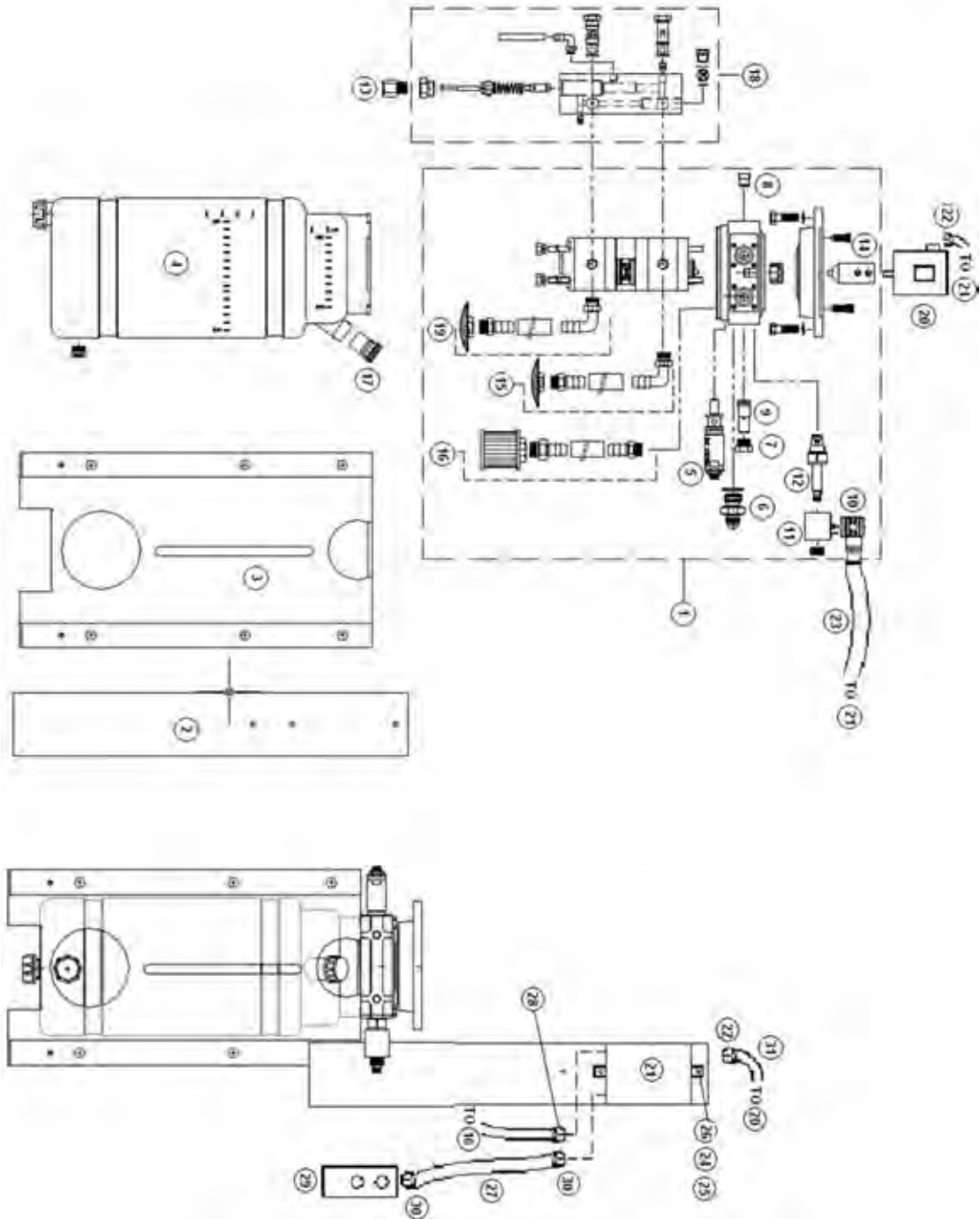

12.10 12,000 LB SPACE SAVER POWER PACK - PARTS LIST

ITEM NO.	QTY.	DESCRIPTION	PART NO.
1	1	PUMP ASSEMBLY	6-3234
2	1	CONTROL BOX BRACKET	6-3225
3	1	PUMP TANK SKIRT	6-3226
4	1	TANK 10L PLASTIC	6-3224
5	1	RELIEF VALVE 5400 PSI	6-3238
6	1	FITTING ¼ BSP - #6 JIC W/ BONDED SEAL	6-3227
7	1	PLUG ¾ - 16 C/W O-RING	6-3230
8	1	CHECK VALVE	6-2985
9	1	FLOW CONTROL – 7.5 L/MIN	6-2988
10	1	DIN CONNECTOR RECTIFIED 1A HIGH BODY	6-2503
11	1	COIL S8 220V RAC	6-2502
12	1	CARTRIDGE VALVE N/C WITH MANUAL	6-2129
13	1	BLEED OFF	6-2531
14	1	MOTOR COUPLER & NOIX CROSS	6-2537
15	1	PUMP INTAKE ASSEMBLY (LONG)	6-2292
16	1	PUMP RETURN ASSEMBLY	6-2290
17	1	PRESS FIT FILLER BREATHER	6-3223
18	1	UNLOADING MANIFOLD ASSEMBLY	6-2555
19	1	PUMP INTAKE ASSEMBLY	6-2293
20A	1	MOTOR, 220V, 1 PHASE	6-0087
20B	1	MOTOR, 220V, 3 PHASE	6-0446
20C	1	MOTOR, 575V, 1 PHASE	6-0447
21A	1	CONTACTOR MOTOR STARTER 220V, 1	6-0805
21B	1	CONTACTOR MOTOR STARTER 220V, 3	6-0809
21C	1	CONTACTOR MOTOR STARTER 575V, 3	6-0449
22	2	½” STRAIN RELIEF CONNECTOR	6-0093
23	3 FT	COIL CABLE	8-0306
24	2	LOCKWASHER, ¼”	6-0056
25	2	CAP SCREW, HEX HEAD, ¼”-UNC x ¾” LG	6-0178
26	2	¼”-20UNC HEX NUT	6-0032
27	1	REMOTE CONTROL CABLE	1-0103
28	1	½” STRAIN CONNECTOR	6-0092
29	1	REMOTE HAND CONTROL	6-0096
30	2	3/8” STRAIN RELIEF CONNECTOR	6-0093
31A	1	MOTOR CABLE (1 PHASE)	1-0104
31B	1	MOTOR CABLE (3 PHASE)	1-1824
***NOTE		PUMP ASSEMBLY (INCLUDES 2 TO 28)	6-3233
		COMPLETE POWERPACK ASSEMBLY 220V, 1	0-0123
		COMPLETE POWERPACK ASSEMBLY 220V, 3	0-0767
		COMPLETE POWERPACK ASSEMBLY 575V, 3	0-0766