

# SAFETY INFORMATION

---

**For your safety, read this manual thoroughly  
before operating the EEWB300A Wheel Balancer**

The Model EEWB300A Wheel Balancer is intended for use by properly trained automotive technicians. The safety messages presented in this section and throughout the manual are reminders to the operator to exercise extreme care when servicing tires with these products.

There are many variations in procedures, techniques, tools, and parts for balancing tires, as well as the skill of the individual doing the work. Because of the vast number of wheel and tire applications and potential uses of the product, the manufacturer cannot possibly anticipate or provide advice or safety messages to cover every situation. It is the automotive technician's responsibility to be knowledgeable of the wheels and tires being serviced. It is essential to use proper service methods in an appropriate and acceptable manner that does not endanger your safety, the safety of others in the work area or the equipment or vehicle being serviced.

It is assumed that, prior to using the Model EEWB300A Wheel Balancer, the operator has a thorough understanding of the wheels and tires being serviced. In addition, it is assumed he has a thorough knowledge of the operation and safety features of the rack, lift, or floor jack being utilized, and has the proper hand and power tools necessary to service the vehicle in a safe manner.

Before using the Model EEWB300A Wheel Balancer, always refer to and follow the safety messages and service procedures provided by the manufacturers of the equipment being used and the vehicle being serviced.



**IMPORTANT !! SAVE THESE INSTRUCTIONS -- DO NOT DISCARD !!**

## **IMPORTANT SAFETY INSTRUCTIONS**

When using this equipment, basic safety precautions should always be followed, including the following:

1. **Read all instructions.**
2. **Do not operate equipment with a damaged power cord or if the equipment has been damaged - until it has been examined by a qualified authorized service technician.**
3. **If an extension cord is used, a cord with a current rating equal to or more than that of the machine should be used. Cords rated for less current than the equipment may overheat. Care should be taken to arrange the cord so that it will not be tripped over or pulled.**
4. **Always unplug equipment from electrical outlet when not in use. Never use the cord to pull the plug from the outlet. Grasp plug and pull to disconnect.**
5. **To reduce the risk of fire, do not operate equipment in the vicinity of open containers of flammable liquids (gasoline).**
6. **Keep hair, loose fitting clothing, fingers and all parts of the body away from moving parts.**
7. **Adequate ventilation should be provided when working on operating internal combustion engines.**
8. **To reduce the risk of electric shock, do not use on wet surfaces or expose to rain.**
9. **Do not hammer on or hit any part of the control panel with weight pliers.**
10. **Do not disable the hood safety interlock system or bypass the intended operation.**
11. **Do not allow unauthorized personnel to operate the equipment.**
12. **Use only as described in this manual. Use only manufacturer's recommended attachments.**
13. **Always securely tighten the wing nut before spinning the shaft.**
14. **ALWAYS WEAR SAFETY GLASSES. Everyday eyeglasses only have impact resistant lenses, they are NOT safety glasses.**
15. **Balancer is for indoor use only.**

**SAVE THESE INSTRUCTIONS**

**TABLE OF CONTENTS**

1.0	Introduction	Page 4
1.1	Use Limitations	Page 4
1.2	Notice	Page 4
1.3	General Safety Instructions	Page 4
1.4	Terminology	Page 4
1.5	Specifications	Page 5
1.6	Dimensions Of The Machine	Page 5
1.7	Standard Accessories	Page 5
1.8	Optional Accessories	Page 6
1.9	Safety Precautions	Page 6
1.10	Safety Devices	Page 6
2.0	Installation Area	Page 7
3.0	Installation Instructions	Page 8
3.1	Electric Installation	Page 9
4.0	Controls	Page 9
5.0	Mounting The Wheel	Page 10
5.1	Centering Wheels With A True Center Hole	Page 10
5.2	Centering Light-truck Wheels	Page 11
5.3	Balancing Wheels Without A Center Hole	Page 11
6.0	Balancing Procedure	Page 12
6.1	Wheel Data Entry	Page 12
6.2	Balancing Programs. Alu Functions	Page 13
6.3	Alu-Special Program	Page 14
6.4	Correction Of The Imbalance	Page 15
6.5	Verification Of The Results	Page 15
6.6	After Balance Vibration Problems	Page 15
7.0	Tire Matching Program	Page 16
7.1	Dynamic Tire Matching	Page 16
7.2	Static Tire Matching	Page 17
8.0	Self Calibration	Page 18
8.1	Ounce/Grams Conversion	Page 18
8.2	Fine Balancing Mode	Page 18
8.3	Rim Diameter In Millimeters	Page 18
8.4	Offset Gauge Calibration	Page 19
8.5	Diameter Gauge Calibration	Page 19
8.6	Stop-on-top Calibration	Page 20
8.7	Self-diagnostic Program	Page 20
9.0	Maintenance	Page 20
10.0	Moving The Machine	Page 20
11.0	Putting The Machine Out Of Service	Page 20
13.0	Trouble Shooting	Page 21

## 1.0 INTRODUCTION

Congratulations on purchasing the EEWB300A computer wheel balancer.

This wheel balancer is designed for ease of operation, accuracy, reliability and speed.

With a minimum of maintenance and care your wheel balancer will provide many years of trouble-free operation. Instructions on use, maintenance and operational requirements of the machine are covered in this manual.



**STORE THIS MANUAL IN A SAFE PLACE FOR FUTURE REFERENCE. READ THIS MANUAL THOROUGHLY BEFORE USING THE MACHINE.**

## 1.1 USE LIMITATIONS

*The wheel balancer model EEWB300A is intended to be used as a device to balance car, light commercial vehicle and motorcycle wheels with the following specifications:*

**Maximum wheel diameter :** 35"1/2 (900mm)  
**Maximum wheel width :** 14"3/4 (375mm)  
**Maximum wheel weight :** 143lbs (65 kg)

*This device is to be only used in the application for which it is specifically designed.*

*Any other use shall be considered as improper and thus not reasonable.*

*The manufacturer shall not be considered liable for possible damages caused by improper, wrong or non reasonable use.*

## 1.2 NOTICE

This manual is a part of the product. Read carefully the warnings and instructions of this manual since they provide important information concerning safety and maintenance.

## 1.3 GENERAL SAFETY INSTRUCTIONS

**THE USE OF THIS DEVICE IS ALLOWED ONLY TO PERSONNEL DULY TRAINED BY AN AUTHORIZED SNAP-ON DEALER.**

**ANY MISUSE OR MODIFICATION OF THIS DEVICE OR OF ITS PARTS OR COMPONENTS NOT PREVIOUSLY AUTHORIZED BY THE MANUFACTURER WAIVE THE MANUFACTURER FROM ANY DAMAGE CONSEQUENT OR RELATED TO THE ABOVE MENTIONED MISUSES.**

**REMOVING OR BYPASSING SAFETY DEVICES OR WARNING LABELS OF THE MACHINE IS A VIOLATION OF THE SAFETY REGULATIONS.**

**THE USE OF THIS DEVICE IS ALLOWED ONLY IN LOCATIONS WITH NO EXPLOSION OR FIRE HAZARD.**

**THIS EQUIPMENT IS DESIGNED TO RECEIVE ORIGINAL SPARE PARTS AND ACCESSORIES ONLY.**

**THE INSTALLATION SHALL BE CARRIED OUT ONLY BY QUALIFIED PERSONNEL AND WITHIN THE SCOPE OF THE INSTRUCTIONS PROVIDED IN THIS MANUAL.**

**CHECK FOR POSSIBLE DANGEROUS CONDITIONS DURING THE OPERATION OF THE MACHINE. IN SUCH A CASE STOP THE MACHINE IMMEDIATELY. IN CASE A DEFECTIVE FUNCTIONING CONDITION IS DETECTED, STOP USING THE MACHINE AND CALL THE AUTHORIZED SNAP-ON SERVICE AT 1-800-225-5786.**



**ALL ELECTRICAL CONNECTIONS SHALL BE PERFORMED BY A LICENSED TECHNICIAN. ALL SERVICE MUST BE PERFORMED BY AN AUTHORIZED SERVICE TECHNICIAN.**

## 1.4 TERMINOLOGY

Before installing and using the wheel balancer it is suggested that you become familiar with the terminology of the machine's components.

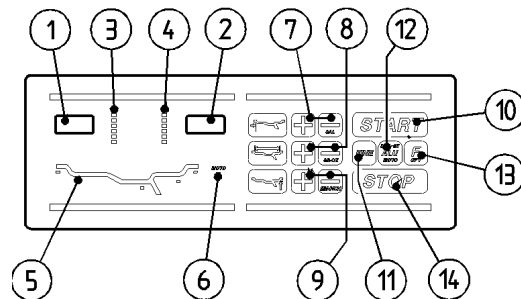
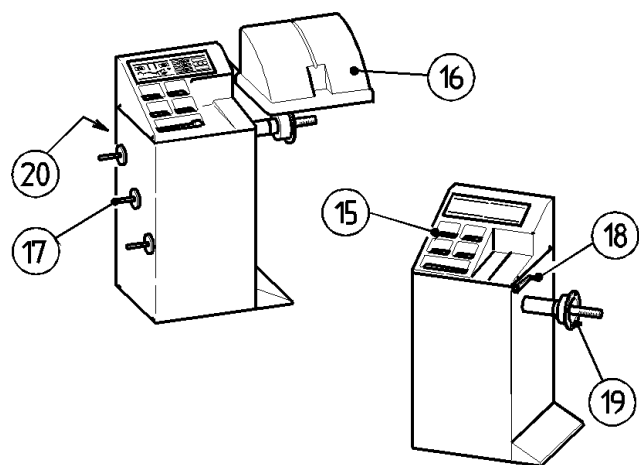

Fig.1

1. **Display for inner plane imbalance**
2. **Display for outer plane imbalance**
3. **Display for position of inner plane imbalance**
4. **Display for position of outer plane imbalance**
5. **Display for wheel weight location**
6. **Display for motorcycle dynamic program**
7. **Rim offset buttons**
8. **Rim width buttons**
9. **Rim diameter buttons**
10. **START button**
11. **FINE' balancing button**
12. **Balancing programs button**
13. **Multi-function/OPTimizing button**
14. **STOP button**

914



- 15. Wheel weight tray
- 16. Wheel guard (Optional)
- 17. Accessories location
- 18. Rim offset (diameter) gauge
- 19. Arbor
- 20. Main ON/OFF switch

### 1.5 SPECIFICATIONS

Microprocessor wheel balancer for car, light commercial vehicle and motorcycle wheels	
Weight with standard acc.	210 lbs (Kg 95)
Electric specifications	115VAC, 1ph, 50-60Hz, 8A
Motor power	kW 0.25
Rim diameter range	10"-24" (250-610mm)
Rim width range	1.5"-20" (38-508mm)
Max. tire diameter	35"1/2 (mm900)
Max. tire width	14"3/4 (mm375)
Max. wheel weight	143lbs (kg65)
Acoustic pressure	70dBA

### 1.6 DIMENSIONS OF THE MACHINE

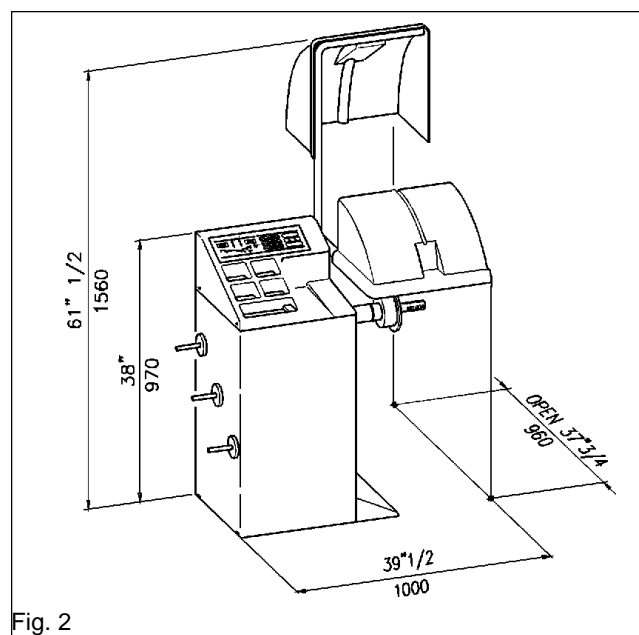

Fig. 2

### 1.7 STANDARD ACCESSORIES

#EAA0247G21A Wheel Caliper (Fig.3).  
To measure the rim width.

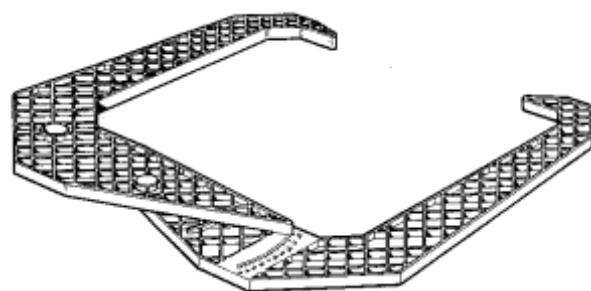

Fig.3

#EAA0247G50A Centering cones with quick nut (Fig.4).  
For centering of wheels with center holes  
Description on use is in section 5.1

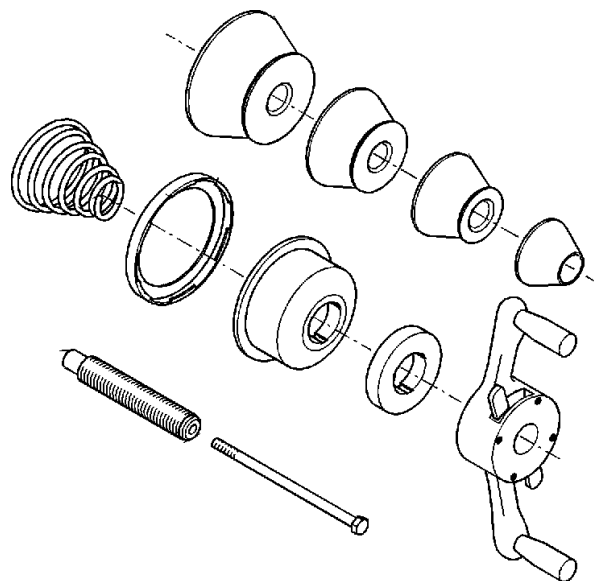

Fig.4

**1.8 OPTIONAL ACCESSORIES**

**#EAM002G04A Extension Adaptors** (Fig.10).  
Used for some light truck wheels, reverse offset wheels and any application where wheel must be away from machine. Description on use is provided in section 5.3.

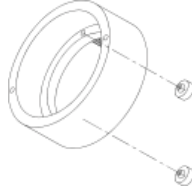

Fig. 6  
**#EAA0247G23A Wheel guard** (Fig.6).  
Protects the operator from abrasions or projections of wheel weights and debris.

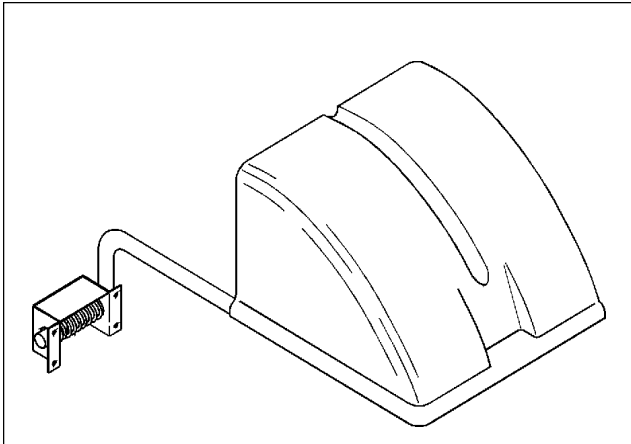

Fig.5

925

916

**1.9 SAFETY PRECAUTIONS**

**A. DURING THE USE AND MAINTENANCE OF THE MACHINE IT IS MANDATORY TO COMPLY WITH ALL LAWS AND REGULATIONS FOR ACCIDENT PREVENTION.**

**B. THE ELECTRIC POWER SOURCE MUST HAVE A GROUND CABLE AND THE GROUND CABLE OF THE MACHINE (YELLOW WITH GREEN) MUST BE CONNECTED TO THE GROUND CABLE OF THE POWER SOURCE.**

**C. BEFORE ANY MAINTENANCE OR REPAIRS ARE ACCOMPLISHED THE MACHINE MUST BE DISCONNECTED FROM THE ELECTRIC SUPPLY.**

**D. NEVER WEAR TIES, CHAINS OR OTHER LOOSE ARTICLES WHEN USING, MAINTAINING OR REPAIRING THE MACHINE. LONG HAIR IS ALSO DANGEROUS AND SHOULD BE KEPT UNDER A HAT. THE USER MUST WEAR PROPER SAFETY ATTIRE IE; GLOVES, SAFETY SHOES AND GLASSES.**

**E. MAINTAIN ALL ELECTRIC CORDS IN GOOD REPAIR.**

**F. KEEP GUARD AND SAFETY FEATURES IN PLACE AND IN WORKING ORDER.**

**G. KEEP WORKING AREA CLEAN. CLUTTERED AREAS INVITE ACCIDENTS.**

**H. AVOID DANGEROUS ENVIRONMENTS. DON'T USE POWER TOOLS OR ELECTRICAL EQUIPMENT IN DAMP OR WET LOCATIONS, OR EXPOSE THEM TO RAIN.**

**J. KEEP THE WORK AREA WELL LIGHTED.**

**1.10 SAFETY DEVICES**

There is a **STOP** button on the control panel.

This machine is available with an optional wheel guard to protect the operator form hazards due to loose wheels, abrasion and projection of wheel weights and debris.

## 2.2 INSTALLATION AREA

Install the machine in a covered and dry area.

The installation of the machine requires a free space of at least cm 6'3" x 6'8" (190 x 200mm) (Fig.19).

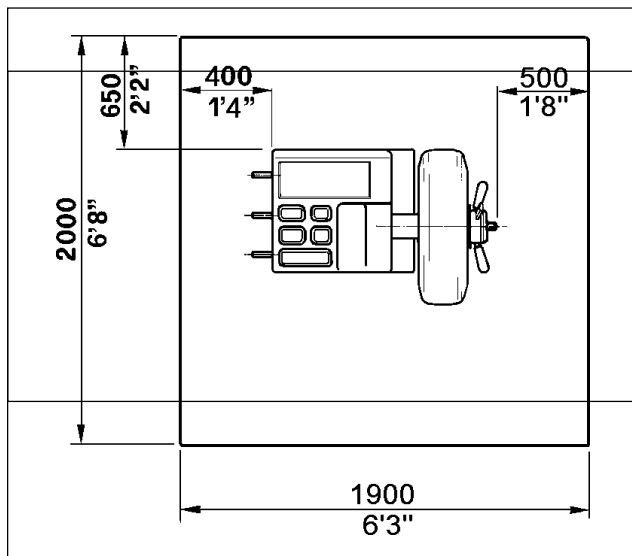

Fig.19

915

Make sure that from the operating position the user can see all of the machine and the surrounding area.

The operator shall forbid, in such an area, the presence of non authorized persons and/or objects which may create possible hazards.

The machine shall be installed on a horizontal floor preferably even. Do not install the machine on a sinking or irregular floor.

In case the machine is installed on a raised floor, the floor must have a capacity of at least 110lbs per sq ft. (5000 N/m<sup>2</sup> - 500 kg/m<sup>2</sup>).

It is not required to secure the machine to the floor, however it is recommended for optimum use.

**3.0 INSTALLATION INSTRUCTIONS**

To install the machine proceed as follows:

**A.** Install the accessories pegs (Fig.20). Tighten them firmly.

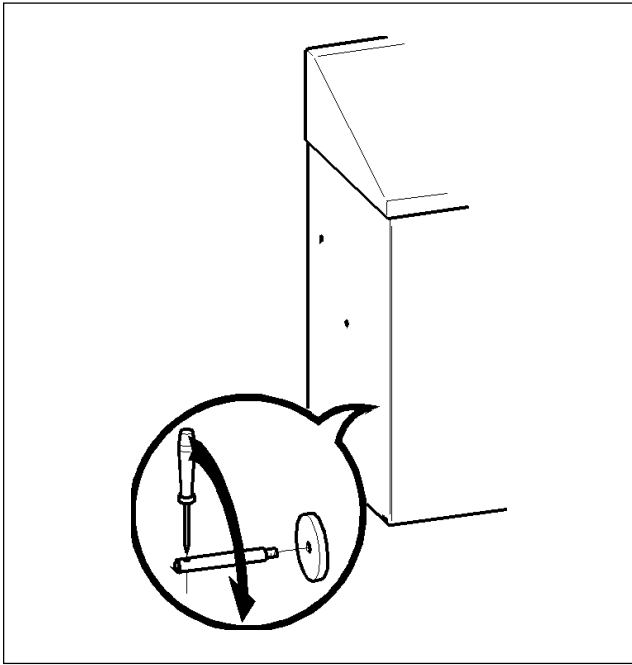

Fig.20

147

**B.** Remove the screws that secure the machine to the pallet and slide it onto the floor where it is to be installed. Hold the machine on the wheel guard support tube and on the accessories pegs (Fig.21).

**CAUTION! CAREFULLY REMOVE THE BALANCER FROM THE PALLET. THE UNIT IS HEAVY AND THE WEIGHT IS NOT EVENLY DISTRIBUTED. DROPPING THE UNIT MAY CAUSE PERSONAL INJURY OR EQUIPMENT DAMAGE.**

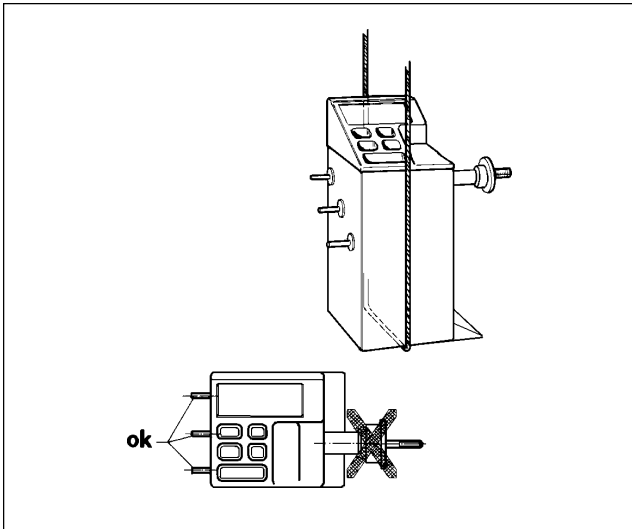
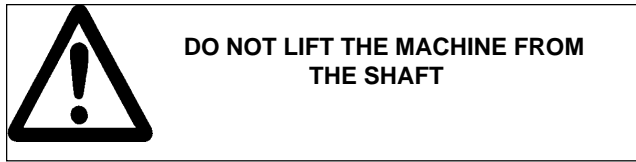

Fig.21

913



**C.** If you have purchased the optional wheel guard, install it now. (Fig.22).

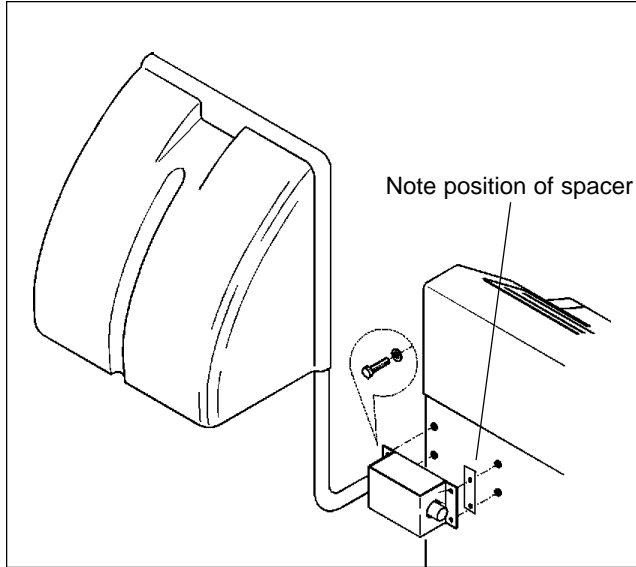

Fig.22

917

**CAUTION! CAREFULLY HOLD THE HOOD WHILE INSTALLING THE SCREWS.**

**D.** Place the cones and other accessories onto the supports provided.



### 3.1 ELECTRIC INSTALLATION



**ALL ELECTRICAL CONNECTIONS SHALL BE PERFORMED BY A LICENSED TECHNICIAN. ALL SERVICE MUST BE PERFORMED BY AN AUTHORIZED SERVICE TECHNICIAN.**

Check on the plate of the machine that the electrical specifications of the power source are the same as the machine. The machine uses 115VAC, 50-60Hz, 1Ph, 8 Amp. Electrical specifications are clearly marked on a label at the end of the electric cord.

Before connecting the machine to the power source, check that the power supply has an efficient grounding system.

**NOTE:**

The outlet installation must be verified by a licensed electrician before connecting the balancer.

**NOTE:**

The yellow with green wire in the cord is the grounding wire. Never connect the grounding wire to a live terminal.

Check that the power supply has an automatic circuit breaker with a differential circuit set at 30 mA.

The electric motor operates in a wide voltage range (plus 10% - minus 7%) and frequency range (50 or 60 cycles) and has a class of insulation suitable for hot and moist climates.

### 4.0 CONTROLS

The function of all the controls is very easily understood while you use the machine.

Refer to section 6.1 - 8.5.

Remember that in case of any problem or emergency the **STOP** button will stop all functions of the machine.

**5.0 MOUNTING THE WHEEL**

Before starting any balancing procedure it is very important that the wheel is mounted on the machine with the proper adaptors.

An incorrect centering of the wheel will result in considerable imbalance.

There are many types of wheels and SNAP-ON supplies adaptors of good quality and durability for the large majority. However if you meet special wheels which may require a specific adaptor, call your authorized SNAP-ON distributor. The rims may be divided into these major groups:

- A. Car rims with a true center hole.**
- B. Car rims without a center hole.**
- C. Car rims with an untrue center hole.**
- D. Light truck rims.**

**5.1 CENTERING WHEELS WITH A TRUE CENTER HOLE**

This is the most common type of car rims, either in steel or light alloy.

These rims can be correctly centered on the middle hole with a steel cone included in the standard accessories.

On most wheels, the inner side of the wheel hub usually has the most uniform surface for wheel balancing.

Always center the wheel by the most uniformly shaped side of the hub to achieve the most accurate balance.

- A. Mount the threaded shaft onto the arbor of the balancer. Tighten firmly (Fig.23).**

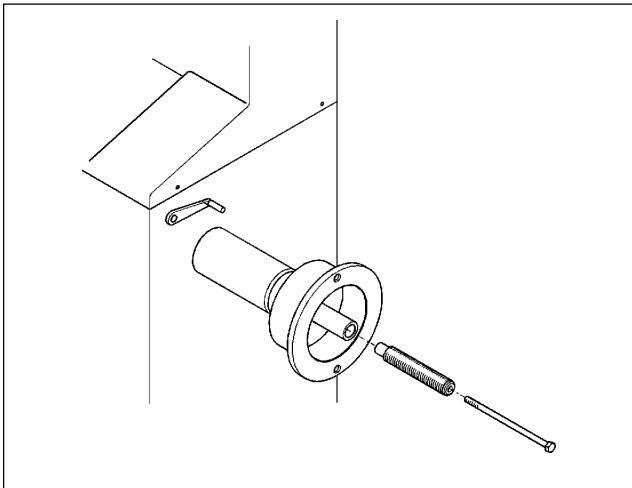

Fig.23

923

**IMPORTANT!**  
**CHECK THAT THE TAPERED SURFACES ARE PERFECTLY CLEAN AND NOT DAMAGED. AN INCORRECT MOUNTING MAY RESULT IN SIGNIFICANT IMBALANCE.**

- B. Choose the cone that best fits the size of the center hole of the wheel.**

- C. Slide the spring and the cone (#1,#2 Fig.24) onto the shaft of the balancer, now mount the wheel. A spring to maintain a sufficient pressure on the cone to center the wheel properly. Secure the wheel with the quick nut (#6 Fig.24) and attached plastic drum (#4 Fig.24).**

If the rim is made of a light alloy, attach the rubber protector (#3 Fig.24) to the plastic drum. In certain types of rims it is required to use the plastic ring (#5 Fig.24).

The plastic drum or plastic ring can be attached to the quick nut by a light hand pressure.

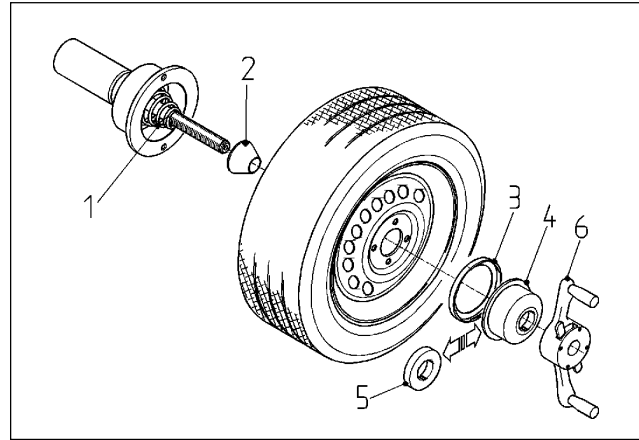

Fig. 24

921

- D. To operate the quick nut pull the lock-unlock lever (Fig.25). Slide the quick nut on the threaded shaft. When in contact with the rim, release the unlock lever and tighten firmly. To assist in centering the wheel properly, rotate the wheel on the shaft while tightening the quick nut.**

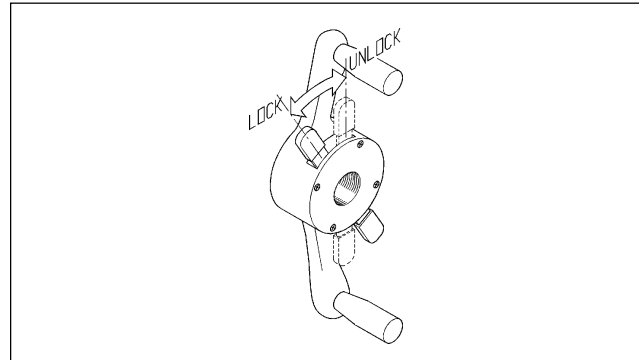
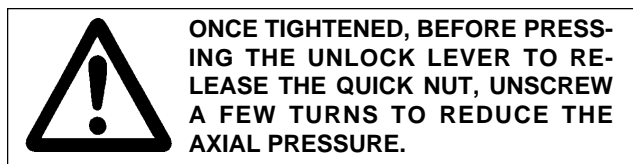
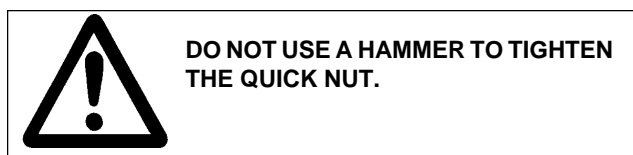

Fig.25

920



**E.** If the hole of the rim runs true on the outside of the rim, the rim can be mounted with a cone from the outside. This method is used on most light truck or 4-wheel drive steel rims (Fig.26). In this case do not use the plastic drum. If needed use an additional cone as a spacer.

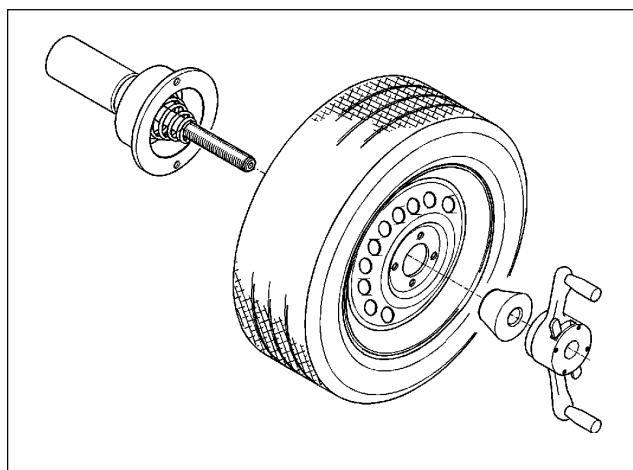

Fig.26

922

**F.** Check that the wheel runs correctly by turning the wheel by hand.

## 5.2 CENTERING LIGHT-TRUCK WHEELS

The extension adaptor (EAM0002G04A) may be required for some light truck wheels and reverse-offset wheels that must be moved away from the balancer mounting flange. The extension adaptor is often used with the 5-1/2-inch diameter light truck cone.

Install the extension adaptor on the mounting flange with the knurled thumbnuts provided. Then mount the wheel, using the normal front cone method (Fig. 32)

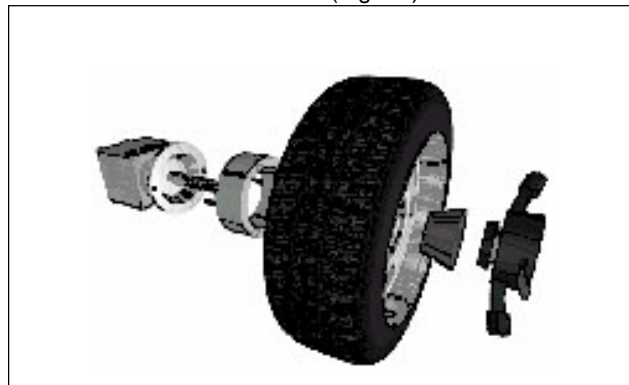

924

Fig. 32

### 6.0 BALANCING PROCEDURE

Once the wheel is properly mounted onto the balancer, turn the machine on.

The machine shows all the displays illuminated for two seconds, as a check. After that, the imbalance displays blink [diS ] [ 60].

Remove all wheel weights from the rim including tape weights.

### 6.1 WHEEL DATA ENTRY

**A.** Measure the rim offset and diameter with the gauge as shown in Fig.42. Hold the gauge steady until the displays blink the value of the rim diameter (left) and rim offset (right). Values will be entered automatically.

**B.** Rim offset can be entered manually if desired. Measure the rim offset with gauge (Fig.42).

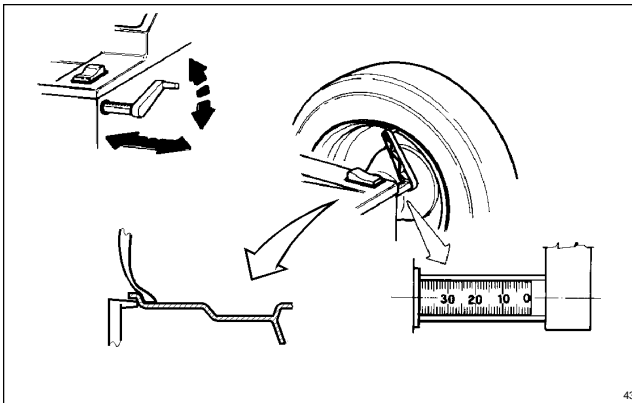

Fig.42

Press button #1 or #2 to raise or lower the offset number as required. (Fig. 43) to enter rim offset.

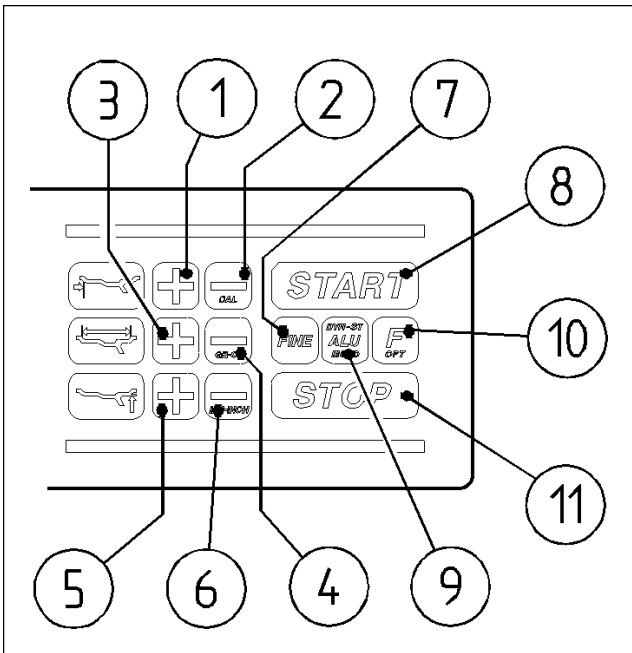

Fig.43

**C.** Rim diameter can be entered manually. Read the rim diameter, always marked on the sidewall of the tire (Fig.44). Press button #5 or #6 (Fig. 43) to raise or lower the offset number as required.

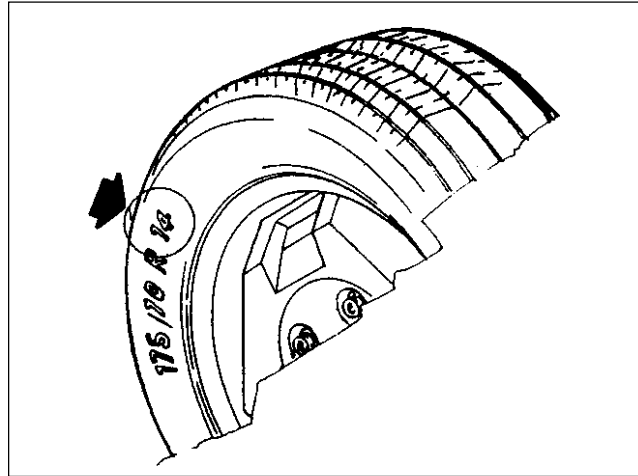

Fig.44

**D.** Measure the rim width with the wheel caliper (Fig.45).

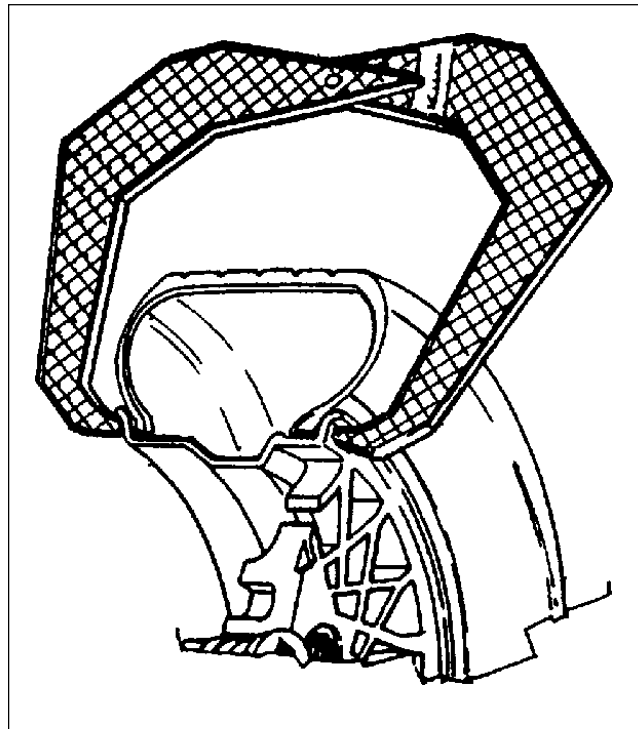

Fig.45

**E.** Enter rim width with the appropriate buttons (#3 and #4 Fig.43).

**F.** To enter all data with an increased resolution press the button 'FINE' first (#7 Fig.43). Press the button again to restore the standard accuracy.

**6.2 BALANCING PROGRAMS. ALU FUNCTIONS**

Before spinning the wheel (although it may be done afterwards) choose the adequate balancing program. To select the different balancing programs press the button **ALU** (#9 Fig.43). The balancing programs available are :

**A. DYNAMIC** (two planes), suggested for all steel rims. In this case the wheel weights must be clipped onto the rim edges. This function is selected as a default and the LEDs corresponding to the wheel weight location are lit on (Fig.47).

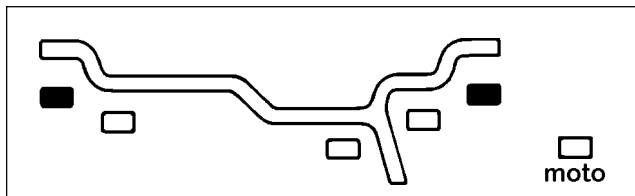

Fig. 47

**B. ALU1.** The wheel weights position is as indicated in Fig.48. In this case use tape weights.

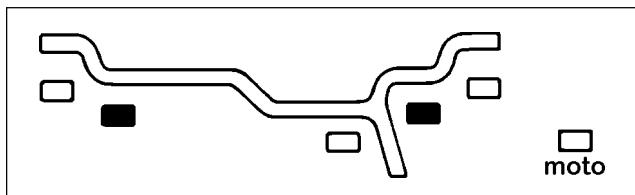

Fig.48

**C. ALU2.** The wheel weights position is as indicated in Fig.49. In this case use one tape weight on the inside and a clip-on weight on the outer edge.

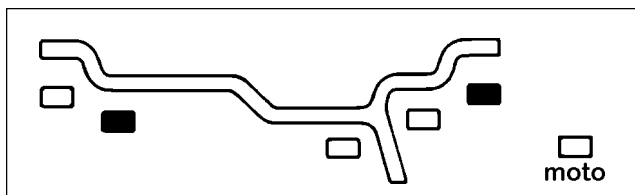

Fig.49

**D. ALU3.** The wheel weights position is as indicated in Fig.50. In this case use one tape weight on the outside and a clip-on weight on the inner edge.

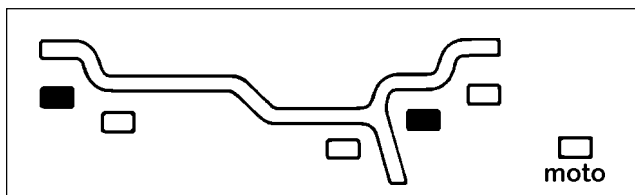

Fig.50

**E. ALU4.** The wheel weights position is as indicated in Fig.51. In this case use hidden tape weights.

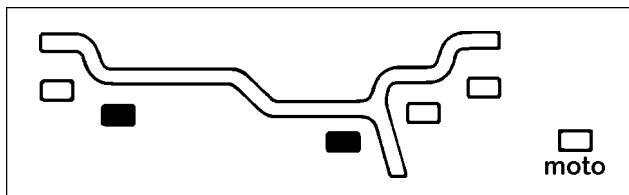

Fig.51

**F. ALU5.** The wheel weights position is as indicated in Fig.52. In this case use one tape weight on the inside and a clip-on weight on the inner edge.

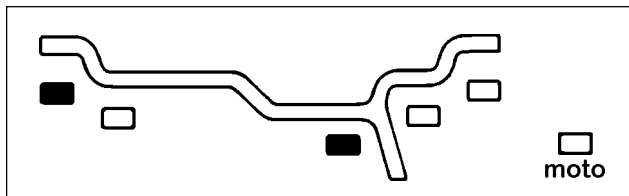

Fig.52

**G. ALU6.** The wheel weights position is as indicated in Fig.53. In this case use one hidden tape weight on the inside and a clip-on weight on the outer edge.

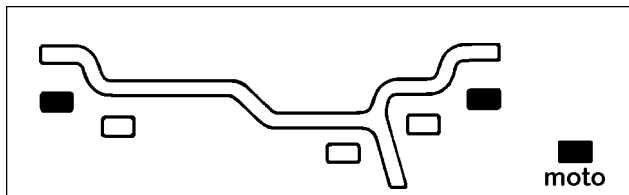

Fig. 53

NOTE :

TO RETURN TO THE *DYNAMIC* PROGRAM FROM ANY OF THE *ALU* PROGRAMS, JUST PRESS **STOP**.

**H. STATIC** (one plane - Fig.54). Suggested for narrow car rims (3" or less). To enter the *Static* program press the **ALU** button and hold it for 3 sec). Do the same operation to return to the previous active balancing program.

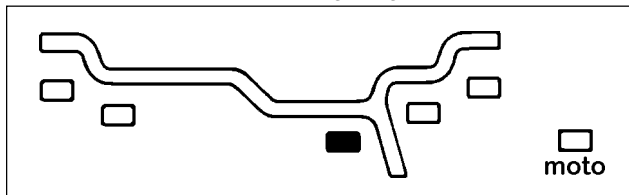

Fig.54

### 6.3 ALU-SPECIAL PROGRAM

The programs for ALU wheels are always an approximation and their accuracy depends on the shape of the rim.

Especially when using the hidden weights method (*ALU4*) relevant differences may be noticed from rim to rim.

In such a case, it is convenient to activate the *ALU SPECIAL* program that defines the exact positions of the balancing planes, diameters and angular position and allows successful balancing at the first spin.

To activate the program:

**A.** Move the offset/diameter gauge to the position where the inner wheel weight will be fitted (measure A Fig.55). Hold the gauge steady until the values of diameter and offset blink displays #1 and #2 Fig.56).

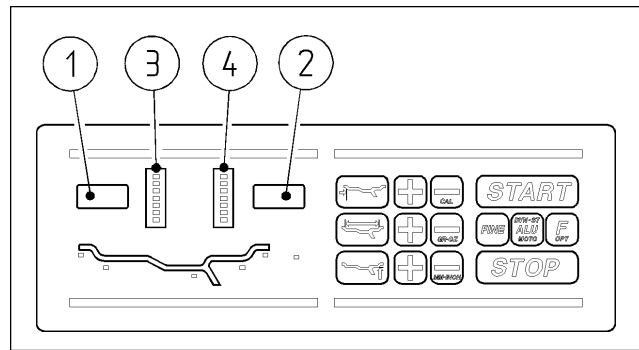
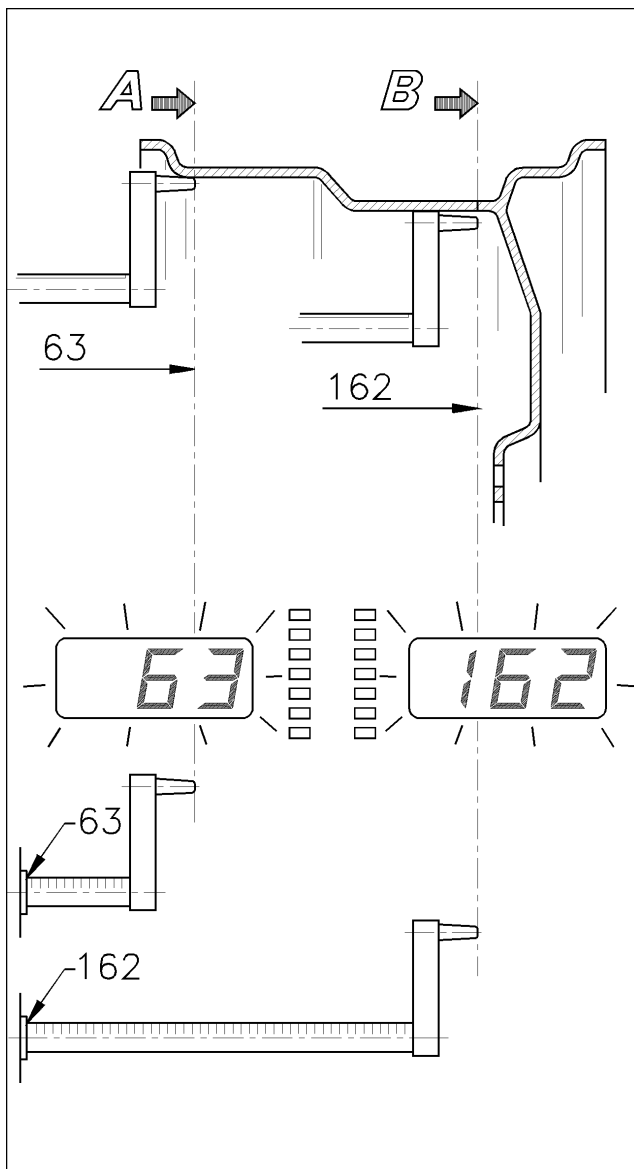

**Fig. 56**

160

**B.** Now extract further the offset/diameter gauge to point to the position of the second correction plane (measure B Fig.55). Hold the gauge steady until the values of diameter and offset blink again.

**C.** On the displays is shown for a short period the message: [ALU] [-S-] and the LED's of the wheel weight location goes off. The program is active now.

**D.** Move the gauge to the rest position to enter all values. The input of the rim width in this case is not necessary.

**SPECIAL NOTE:**

TO ACTIVATE *ALU S* PROGRAM THE DIFFERENCE BETWEEN MEASUREMENT 'A' AND MEASUREMENT 'B' FIG.57 HAS TO BE AT LEAST 50 MM (2").

**E.** Do the operations described in section 6.4 A and B.

**F.** The EXACT location where to put the weight can be determined by pulling the gauge arm out and touching the rim. The offset values of both correction planes entered will blink on displays when the gauge is extracted from its position.

The correct offset position and angular position where to tape the weight on each plane is reached when the gauge reads the values blinking on the inner and outer plane respectively (Fig. 55).

**G.** To exit the program press the **ST-DYN (ALU)/STOP** button. The program will automatically switch to *Dynamic*.

Fig. 55

58

## 6.4 CORRECTION OF THE IMBALANCE

### A. Press start button to spin the wheel

When the balancing cycle is completed (about 7 sec. for an average wheel) the wheel will stop automatically and the imbalance values will appear on the LED's. The wheel will stop in a position close to the correction position for the outer plane (*Stop-on-top*).

**B.** Read the imbalance amount on the outer display (#2 Fig.56). Values are displayed in grams but can be displayed in ounces (see section 8.1) and are automatically rounded to the nearest commercial wheel weight.

Turn the wheel until the displays of the outer plane imbalance position indicator (#4 Fig.56) are illuminated and blinking.

Apply the counterweight at twelve o'clock position.

If the program selected is an *ALU* function, put the wheel weight on this wheel as depicted in the *ALU* function chosen.

**C.** Correct the imbalance on the inner plane in the same way (reading the data on display #1 Fig.56 and LED's #3 Fig.56). If the balancing program selected is *Static*, the correction is made on one plane only.

## 6.5 VERIFICATION OF THE RESULTS

Spin the wheel again and check that the readout is **[ 0 ] [ 0 ]**.

If a residual imbalance is displayed:

**A.** Check the rim parameters, if entered value is incorrect, correct as needed and press the **F** button. Imbalance values will be automatically recomputed.

**B.** Check if the balancing program selected is the most appropriate. If not choose the right program and imbalance values will be automatically recomputed.

**C.** The wheel weight could have been placed at a wrong position. To check this, position the wheel at the correction position for the outer plane.

If the wheel weight previously attached is in sector 'L' or 'R' ( Fig.57), move the wheel weight up about 1" (2cm).

If the wheel weight is in sector 'D' cut a piece of the wheel weight of an approximate value corresponding to the value shown on the right display, or replace the wheel weight with a lighter one.

If the wheel weight is in sector 'U' add a weight of value indicated by the display or replace the wheel weight with a heavier one. Repeat the same operation for the inner plane.

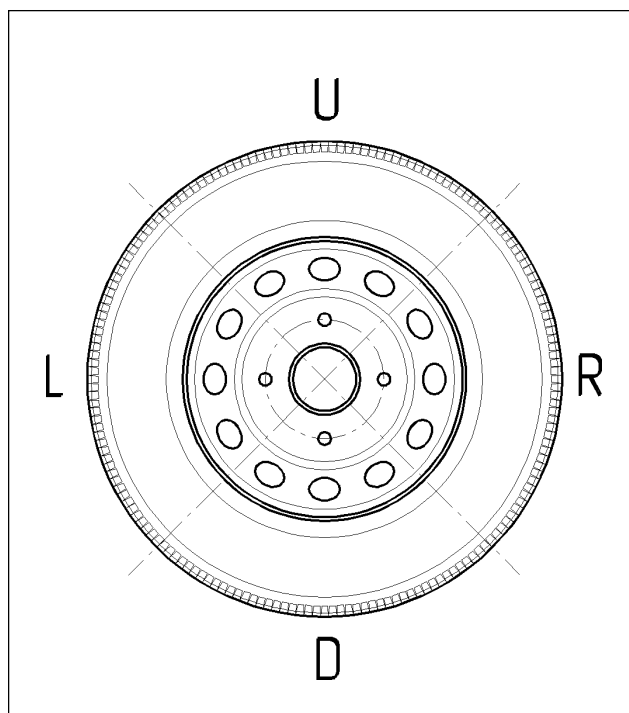

Fig.57

### NOTE:

If this situation is repeated, your machine may be out of calibration and a calibration operation might be required (section 8.0).

**D.** If an *ALU* function was selected ensure that the wheel weights have been placed in accordance to the program chosen.

**E.** Check that the quick nut is tight and that the wheel is not slipping against the backing collar.

**F.** Check that the wheel and adaptors are clean.

## 6.6 AFTER BALANCE VIBRATION PROBLEMS

If vibration is still present after balancing, check the following possible sources of vibration:

1. Stones caught in the tire tread.
2. Tire slippage on the wheel.
3. Incorrectly mounted wheel.
4. Imbalanced wheel covers.
5. Excessive radial or lateral runout in the tire or wheel.
6. Damaged wheel bolt holes.
7. Worn universal joints.
8. Imbalanced brake rotors or drums.

## 7.0 TIRE MATCHING PROGRAM

The matching program assists the user in determining the best possible mating of the tire and rim.

The mating of tire and wheel normally allows the least amount of additional weight required for balancing and total runout.

The matching program is helpful when:

- Excessive radial runout is noticed.
- The balancer calls for weights in excess of 2 oz. on either plane in the *Dynamic* mode.

The EEWB300A computer wheel balancer features 2 different matching programs:

- *Static*, when the tire has a manufacturers determined direction of rotation and cannot be reversed on the rim.
- *Dynamic*, when the mating may require to rotate and reverse the tire on the rim.

### 7.1 DYNAMIC TIRE MATCHING

**A.** Mount the wheel on the machine and enter wheel data as usual. Lower the wheel guard to spin the wheel.

**B.** Once the wheel stops, push and hold the **F** button for 3 seconds or more.

The displays show **[Opt]** and blink **[0— ] [ —0]**.

**NOTE :**

If the imbalance is lower than 2 oz (50 gr) the displays show: **[Opt] [no]**.

To force tire matching, press **F** again.

Press **F** for more than 3 sec. to exit the matching program.

**C.** Mark the tire in line with the valve stem. (Fig.58 #A), which is usually on the outer plane of the wheel.

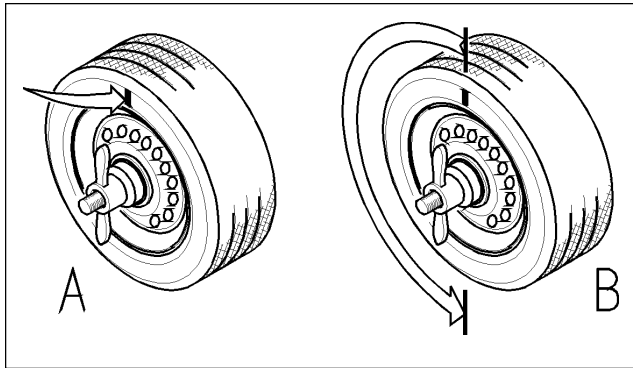

Fig.58

**D.** Rotate the wheel so that the valve is at 12 o'clock and press **F**. Displays show **[Opt]** and blink **[1— ] [ —1]**.

**E.** Dismount the wheel from balancer.

Deflate tire and rotate the tire 180 degrees on the rim (the mark on the tire and the valve shall be at 180 degrees) (Fig.58 #B). Inflate tire to the right pressure **respecting all safety precautions**.

**F.** Mount the wheel onto the balancer with valve at 12 o'clock.

**NOTE:**

**Check that the rim is mounted in the same angular position with respect to the arbor.**

**G.** Spin the wheel.

Displays show : **[Opt]** and blink **[2— ] [ —2]**.

**H.** Move the wheel with the valve at 12 o'clock and press **F**.

Displays show **[Opt] [End]**.

**J.** Rotate the wheel until the angular indicators are all lit (Fig.59).

**NOTE :**

In this program either angular display could be activated.

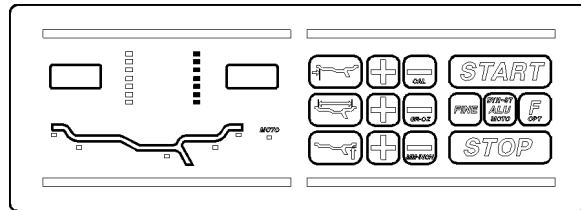

Fig.59

**K.** Mark the *rim* on the inner or outer plane (as indicated by the angular displays lit on) (Fig.60).

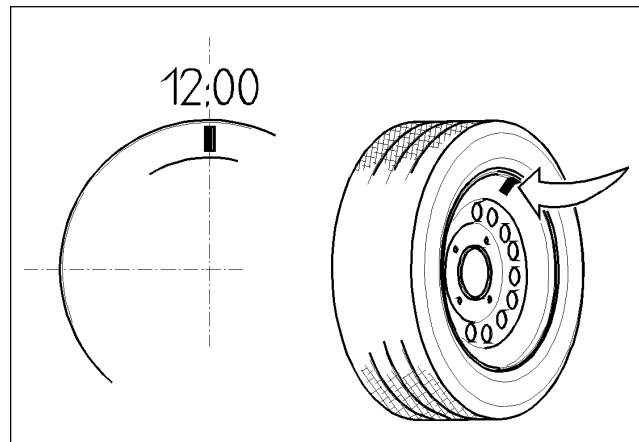

Fig. 60

**L.** Remove the wheel from the balancer and with a tire changer match the marks on the rim and the tire.

**M.** Press **F** to exit the program. Balance the wheel normally.



## 7.2 STATIC TIRE MATCHING

**A.** Mount the wheel on the machine using the suitable flange and enter data as usual. Lower the wheel guard to spin the wheel.

**B.** Once the wheel stops, push and hold the **F** button for 3 seconds. The displays show **[Opt]** and blink **[0— ] [ —0]**.

### NOTE :

If the imbalance is lower than 50 gr (2oz) the displays show: **[Opt] [no]**.

To force tire matching, press **F** again, or hold **F** for more than 3 sec. to exit the matching program.

**C.** Press **DYN-ST(ALU)** .

Displays show:

**[Opt] [0-0]** .

**D.** Mark the tire in line with valve stem (Fig.58 #A), which is usually on the outer plane of the wheel.

**E.** Move the wheel so that the valve is at 12 o'clock and press **F**.

Displays show **[Opt] [1—1]**.

**F.** Dismount the wheel from balancer.

Deflate tire and rotate the tire 180 degrees on the rim (the mark on the tire and the valve shall be at 180 degrees) (Fig.58 #B). Inflate tire to the right pressure **respecting all safety precautions**.

**G.** Mount the wheel onto the balancer with valve at 12 o'clock.

### NOTE:

**Check that the rim is mounted in the same angular position with respect to the arbor.**

**H.** Spin the wheel.

Displays show : **[Opt] [ 2-2]**.

**J.** Move the wheel with the valve at 12 o'clock and press **F**.

Displays show **[Opt] [End]** .

**K.** Rotate the wheel until the outer angular indicators are all lit (Fig.59)

**L.** Mark the rim on the outer plane (as indicated by the angular displays lit).

**M.** Remove the wheel from the balancer and with a tire changer match the marks on the rim and the tire.

**N.** Press **F** to exit the program.  
Balance the wheel normally.

## 8.0 SELF CALIBRATION

All balancers are carefully calibrated by the manufacturer and do not require a new calibration, except after many years of service or in case of replacement of any electronic component.

To recalibrate the machine proceed as follows:

**A.** Switch the machine off.

**B.** Mount a wheel with an average size steel rim ( i.e. 14"), even unbalanced.

**C.** Press **CAL** while turning the machine on. Hold the button for at least 5 sec.

After the lamp test, the displays blink:

**[CAL] [Usr]** then display **[diS] [ 60]**.

**D.** Enter the correct wheel data (section 6.1) and press **F**. The displays show: **[CAL] [ 1 ]**.

### IMPORTANT!

**IF THE WHEEL DATA ENTERED ARE NOT CORRECT, A WRONG CALIBRATION WILL BE MADE AND ALL SUBSEQUENT BALANCING READOUTS WILL BE WRONG.**

**E.** Lower the wheel guard to spin the wheel.

While the wheel is cycling the displays show:

**[CAL] [ 1 ]** and when the wheel stops :

**[100] [Add]** ([4.00] [Add] in ounces).

The inner plane angular displays are illuminated.

**F.** Attach 4 oz (100gr) weight on the inner plane at top, when the angular displays of the inner plane are illuminated. Spin the wheel. While the wheel is cycling the displays show: **[CAL] [ 2 ]**.

**G.** When the wheel stops the displays show two numbers. Press the buttons 1 or 2 (Fig. 61) to change the values. Adjust the numbers to be closest to **[100] [0]** ([4.00] [ 0 ]). Press **F** to confirm.

**H.** The displays show : **[Add] [100]** ([Add] [4.00]).

The outer plane angular displays are illuminated.

Remove the 100gr (4 oz) weight from the inner plane and attach it to the outer plane at top, when the angular displays of the outer plane are illuminated. Spin the wheel. While the wheel is cycling the displays show: **[CAL] [3]**.

**J.** When the wheel stops the displays show two numbers.

Press the buttons 1 or 2 (Fig. 61) to change the values. Adjust the numbers to be closest to **[0] [100]** ([0] [4.00]).

Press **F** to confirm.

**K.** The displays show **[CAL] [End]**.

The program switches automatically to *Dynamic* balancing.

## 8.1 OUNCE/GRAMS CONVERSION

When the machine is first turned on it is preset to display the imbalance in grams.

If the display in ounces is desired, press and hold **F** (#10 Fig. 61) then press **GR-OZ** (#4 Fig.61).

Repeat the procedure for converting back to grams.

It is possible to check if the machine is preset in grams or ounces by observing the displays.

If after turning on the machine the displays show

**[ 0 ] [ 0 ]** the machine is preset in grams.

If after turning on the machine displays show

**[0.00] [ 0.00]** the machine is preset in ounces.

## 8.2 FINE BALANCING MODE

This balancer always measures with the maximum precision available (1gr or 0.1 oz), however values below 5 gr (0.25 oz) are shown as zero.

Values exceeding 5gr (0.25 oz) are rounded to the amount of the nearest commercial wheel weight.

Press and hold the button **FINE** (#7 Fig.61) to display the residual imbalance below 0.25 oz (5 gr) or in any case the value of imbalance with 1gr (0.1 oz) resolution .

## 8.3 RIM DIAMETER IN MILLIMETERS

The rim diameter is normally displayed in inches, however if the value in millimeters is desired, press button 5 or 6 (Fig. 61) , press and hold **F** (#10 Fig. 61) then press **MM- INCH** (#6 Fig.61).

Repeat the above operation to convert back to inches.

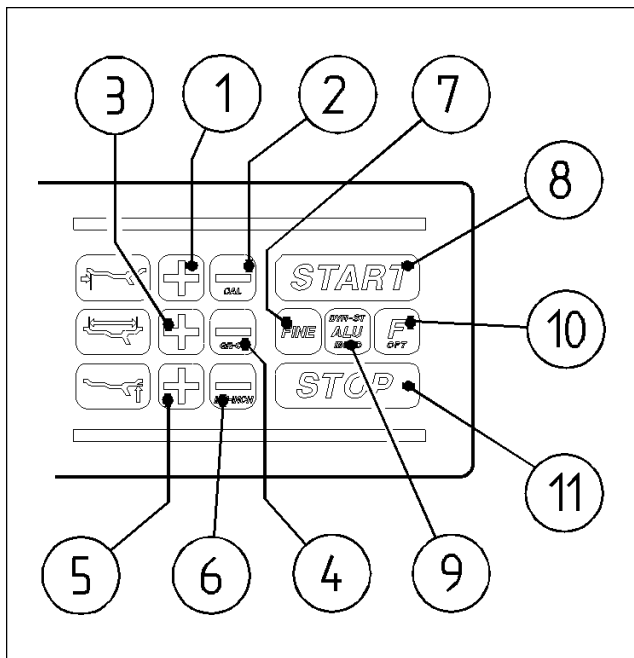

150

Fig.61

### 8.4 OFFSET GAUGE CALIBRATION

To recalibrate the Offset gauge proceed as follows:

**A.** Turn the machine off.

**B.** Press **CAL** (#2 Fig.64) and button #1 Fig.64 for at least 5 sec. while turning the machine on. The displays will blink: **[CAL] [dis]** and then **[dis] [ 0 ]**.

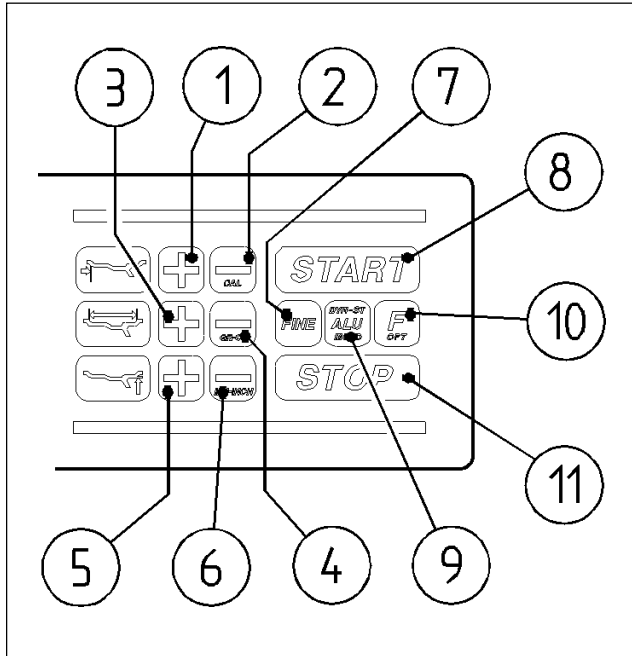

Fig.64

**C.** Set the offset gauge to read '0' on the gauge meter (see Fig.42). While holding the gauge in position, press the **F** button (#10 Fig.64). The displays show **[dis] [160]** .

**D.** Set the offset gauge to read '16'(which is 160mm or 16 cm) on the gauge meter. While holding the gauge in position, press the **F**. The displays show **[CAL] [end]**.

### 8.5 DIAMETER GAUGE CALIBRATION

To recalibrate the diameter gauge proceed as follows:

**A.** Turn the machine off.

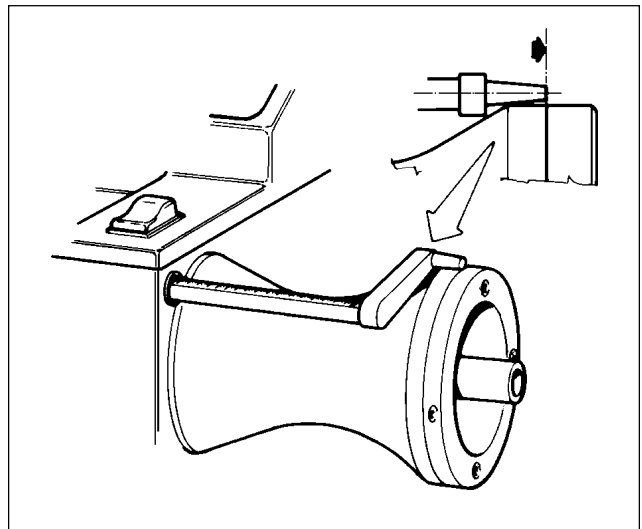

Fig.65

**B.** Press **CAL** (#2 Fig.64) and button #5 Fig.64 while turning the machine on for at least 5 sec. The displays will blink : **[CAL] [dia]** and then **[dia] [FLA]**.

**C.** Move the gauge in contact with the outer diameter of the arbor (Fig.65). While holding the gauge in position, press **F**. The displays will show **[dia] [14]**.

**D.** Move the gauge to a vertical position to match with the reference marks reported on a sticker on the side of the machine (Fig.66) or point to the edge of a 14" wheel. While holding the gauge in position, press **F**. The display shows **[dia] [End]** then **[CAL] [end]**.

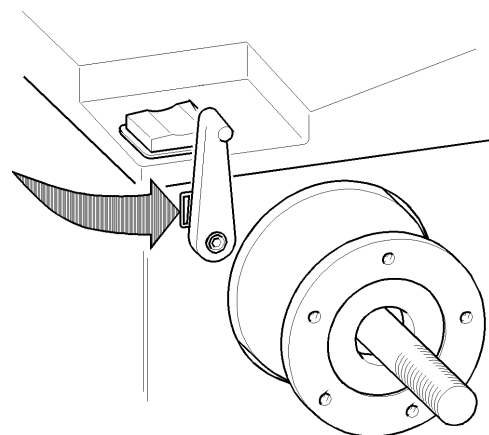

Fig.66

## 8.6 STOP-ON-TOP CALIBRATION

No calibration is required for this feature.

The balancer is equipped with an exclusive program that self-calibrates the balancer automatically during use.

The *Stop-on top* is not effective on wheels with rims smaller than 13".

Heavy wheels will not stop exactly on top but close to the top dead center, because of the inertia.

## 8.7 SELF-DIAGNOSTIC PROGRAM

During the working cycle of the wheel balancer the microprocessor can display some errors which are shown as follows:

**Err 1 :**  
balancing cycle interrupted with the **STOP** button.

**Err 4 :**  
the wheel did not reach the balancing speed.

**Err 6 :**  
no spin before tire matching.

## 9.0 MAINTENANCE

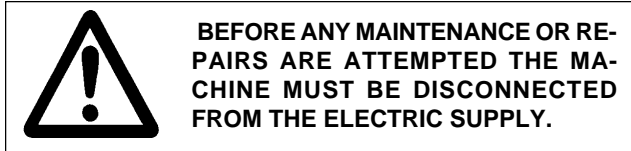

This balancer does not require any special maintenance, but the following precautions are required:

- A.** Periodically wash all plastic parts with a glass cleaner. Wipe with a dry cloth.
- B.** Clean all adapters regularly with a non-flammable liquid detergent all adaptors. Lubricate with a thin layer of oil.

## 10.0 MOVING THE MACHINE

In case the machine is to be moved from one area to another, proceed as follows:

- Disconnect the machine from the electric supply.
- Remove all objects that may fall during the relocation and create a hazard.
- Do not use metal ropes to lift the machine.
- Slide the machine on the forks of a forklift.
- Hold the machine as depicted in Fig. 62.

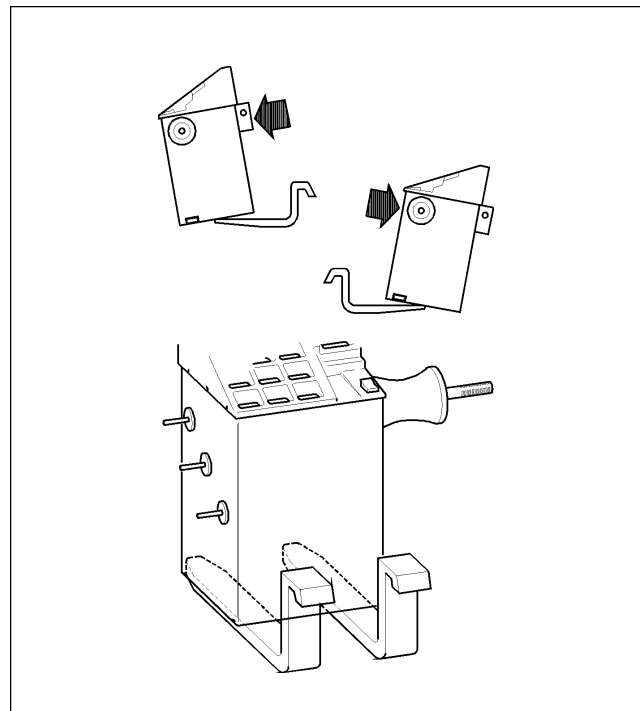

Fig.62

70

## 11.0 PUTTING THE MACHINE OUT OF SERVICE

In case the machine is not to be used for a long period of time (6 months or more) it is necessary to disconnect all power sources and protect all parts that may be damaged. When putting the machine back in operation, check first the condition of all previously protected parts, and check for correct functioning of all devices before using the machine again.

### 13.0 TROUBLE SHOOTING

**TROUBLE**

When turning the machine on, the displays do not light

**CAUSE**

No electric power  
Defect in the electric/electronic system

**REMEDY**

Check the input voltage  
Call the authorized SNAP-ON service center for assistance

The machine gives random read-outs.

Machine unstable on the floor  
Water in the tire  
Loose adaptor  
Defective electronic board

Check that machine is stable  
Remove water from tire.  
Tighten the adaptor firmly  
Call the SNAP-ON service center for assistance

The machine does not stop after balancing cycle.

Defective electronic component

Stop using the machine immediately and call the authorized SNAP-ON service center for assistance.



Snap-on Incorporated  
2801 80th Street  
Kenosha, WI 53141 - 1410

For Service Call:  
1-800-225-5786

**Notice:** The information contained in this document is subject to change without notice. Snap-on Incorporated makes no warranty with regard to this material. Snap-on Incorporated shall not be liable for errors contained herein or for incidental consequential damages in connection with furnishings, performance, or use of this material.

This document contains proprietary information which is protected by copyright and patents. All rights are reserved. No part of this document may be photocopied, reproduced, or translated without prior written consent of Snap-on Incorporated.

***Snap-on*** is a registered trademark of Snap-on Incorporated

---

# EEWB300A COMPUTER WHEEL BALANCER

FOR:

**CAR, LIGHT TRUCK  
AND MOTORCYCLE WHEELS**

OPERATION INSTRUCTIONS

Form ZEEWB300A



---

**Snap-on** <sup>®</sup>