

# Chapter 4

## PRELIMINARY PART REFERENCE

### 8.5 DISPLAY ASSEMBLY

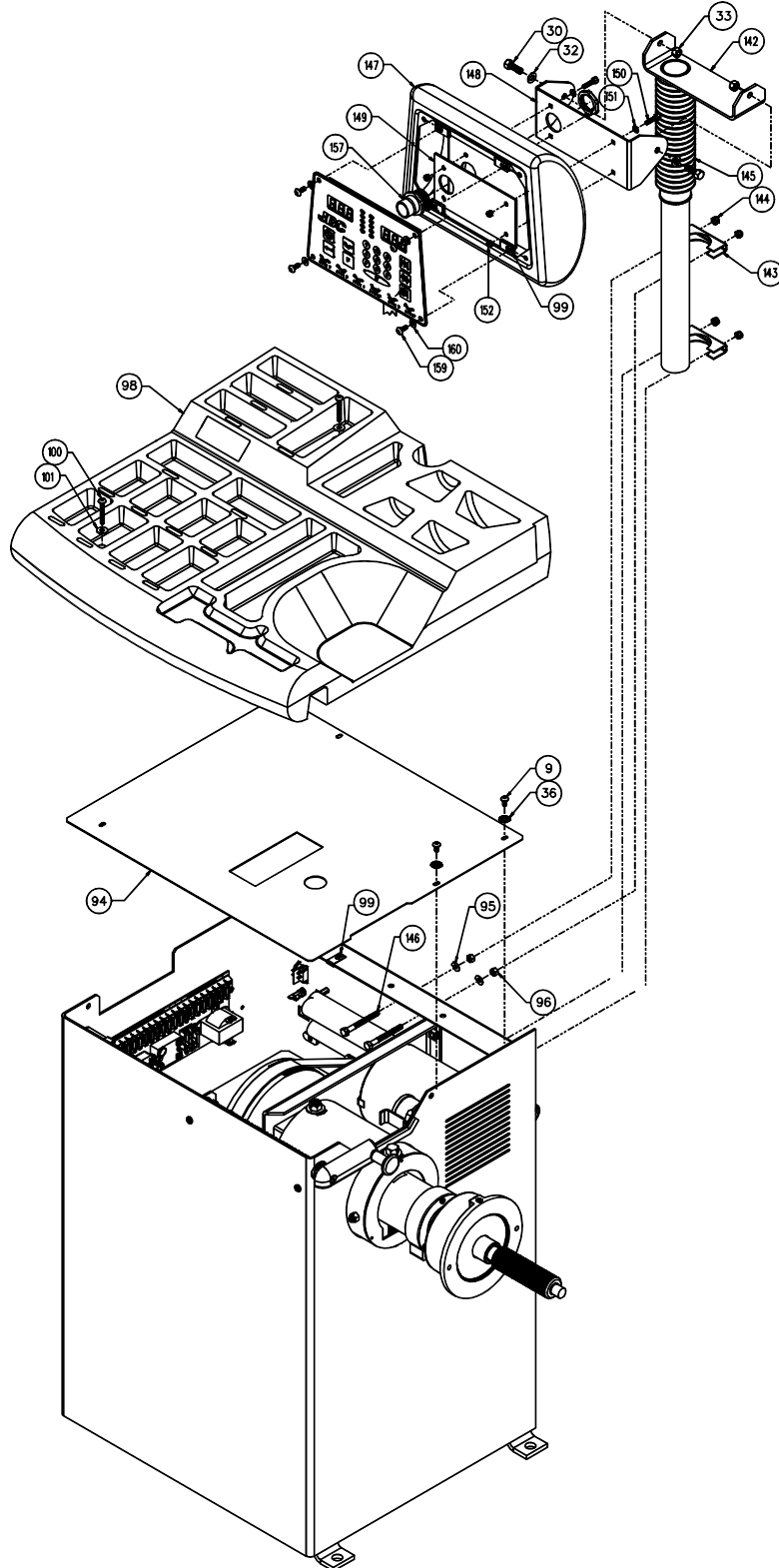

# 8.5 Cabinet and Shaft Assembly

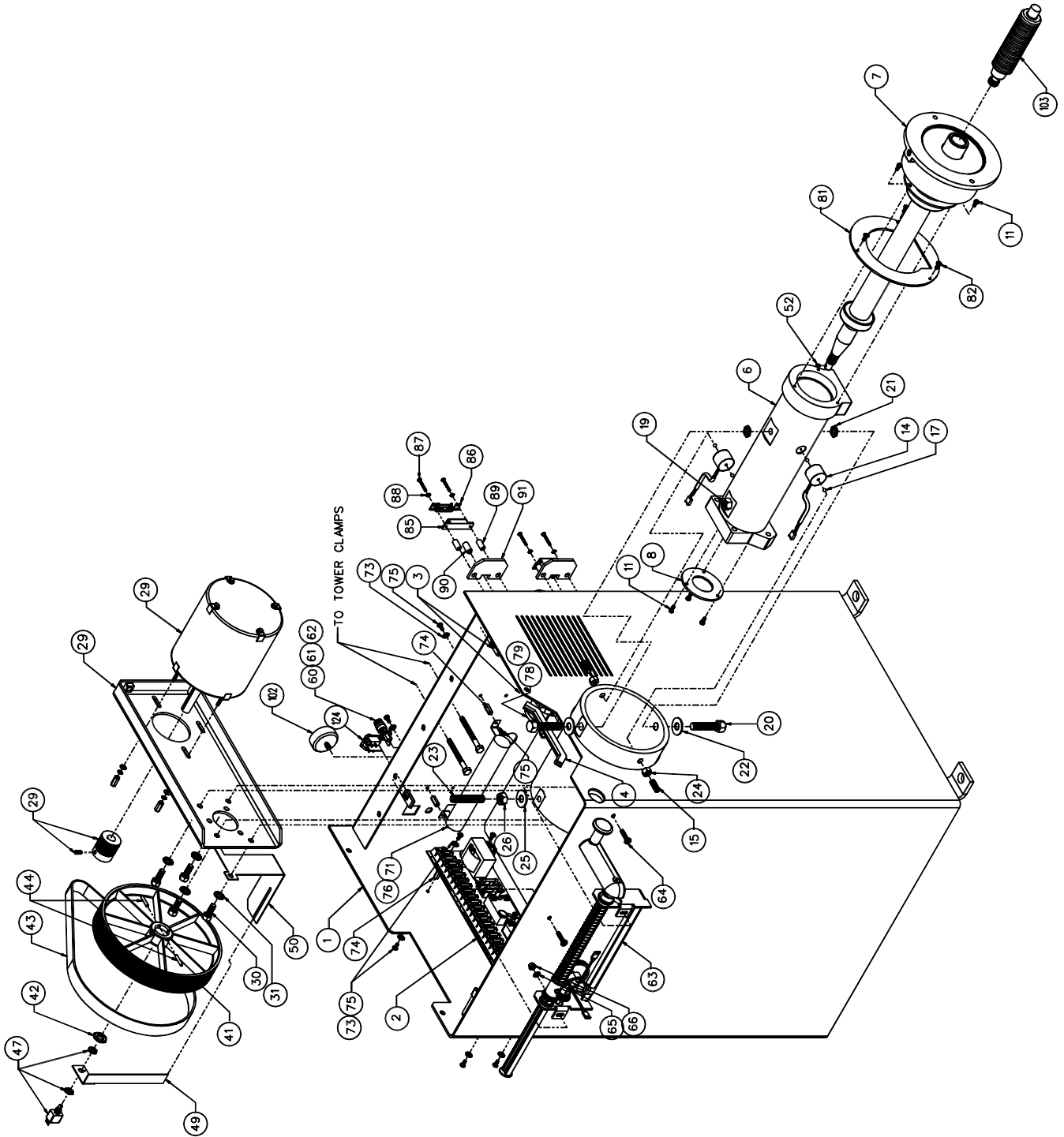

Ref No.	Qty Req'd	Part Number	Part Description
1	1	00112364000	Base Weldment - Cabinet, 8.5
2	1	00112334000	Board Assembly - Motor Control, 8.5
3	2	01101567000	Nut - Speed, #10 - 24 Type U
4	1	00111770000	Trim - Flexible
6	1	00112280000	Tube - Bearing, Machined
<b>7</b>	<b>1</b>	<b>00112377000</b>	<b>Shaft/Bearing Assembly - 8.5</b>
8	1	00061763000	Plate - Bearing, Pre - Load
9	2	01101726000	Screw - Bhcs, #10 - 24 x 1/2 Hs
11	9	01112276000	Screw - Shcs, #10 - 24 x 3/8 Pl
14	2	00112424000	Transducer Assembly - 8.5
15	2	01103509000	Screw - Set, 3/8 - 16 x 1 Hs Cup
17	4	00111286000	Ball - Aluminum O x Ide, 7/32 Dia
19	2	01121510000	Nut - Hex, 7/16 - 14 Unc - 2b Cad/Zn
20	2	01101728000	Bolt - Tap Hex, 1/2 - 13 x 2 1/4
21	2	01121553000	Nut - Jam, 1/2 - 13 Unc - 2b Cad/Zn
22	2	01119966000	Washer - Flat, 7/16 1 1/8od x 1/2i
23	2	01112697000	Screw - Shss - 7/16 - 14 x 2 1/2
24	2	01101410000	Nut - Hex, 3/8 - 16 Nylon Insert
25	2	01100265000	Washer - Flat, 7/16 1 1/4o x 1/2i
26	2	01177980000	Nut - Hex, 7/16 - 14 Lt - Th
<b>29</b>	<b>1</b>	<b>00061949000</b>	<b>Motor Assembly - 115v 60hz - Includes:</b>
	1	00111862000	Motor - 115/230, 1ph
	1	00112278000	Bracket Weldment - Motor Mount
	1	00112290000	Pulley - Small, 60hz
	2	01103444000	Screw - Set, Cp Pt1/4 - 20 x 1/2
	1	01101715000	Joint - Wire Nylon Insul 16 Ga
	1	00061801000	Jumper Assembly - 6"
	2	00061333000	Terminal - Faston, 12 - 10 Ga
	4	00061840000	Washer - Motor, Special
	4	01187949000	Washer - Lock Int/Ext, #10 Zn
	4	00061121000	Spacer - Male/Female
30	6	01100046000	Screw - Hhc, 3/8 - 16 x 1
31	4	01187764000	Washer - Lock Int/Ext, 3/8 Zn
32	2	01100256000	Washer - Flat, 3/8
33	2	01120240000	Nut - Stop, 3/8 - 16 Hex Unc Zn
41	1	00061634000	Pulley - 16 Groove, Molded
42	1	01109591000	Nut - Jam, 5/8 - 18
43	1	00112276000	Belt - Drive (Vendor#380j12)
44	2	01120210000	Pin - Roll, 3/16 x 1
47	1	00110503000	Encoder - Optical, Panel Mt 100p
48	1	00112418000	Harness Assembly - Encoder, 8.5
49	1	00110761000	Mount - Encoder
52	1	01122210000	Screw - Set, Soc Hd #10 - 24 x 1/4
59	1	00112409000	Label - Distance Gage, 8.5
60	1	00064087000	Holder - Fuse
61	1	01104009000	Washer - Lock Int/Ext, 1/2
62	1	00074105000	Fuse - Slow Blow, 1.00a 250v
<b>63</b>	<b>1</b>	<b>00112390000</b>	<b>Gage Assembly - Distance, 8.5</b>
64	2	01112281000	Screw - Shcs, #10 - 24 x 1 Pl
66	2	01101540000	Nut - Keps, 1/4 - 20 Unc - 2b Cd/Zn
71	2	00061653000	Bracket - Mounting, Resistor
73	15	01187949000	Washer - Lock Int/Ext, #10 Zn
74	6	00061121000	Spacer - Male/Female
75	12	01117021000	Screw - Rhms, #10 - 32 x 1/2 Phl Z
76	1	00061654000	Resistor - Brake, 16 Ohm 115v

CHAPTER 4 - PART REFERENCE

Ref No.	Qty Req'd	Part Number	Part Description
78	1	00061765000	Capacitor - Run, 25uf 370v
79	1	00060578000	Clamp - Hose, 2 1/2 - 1 9/16 Id
81	1	00061937000	Cap Assembly - Tube, Suspension
85	2	00061831000	Switch - Interlock
86	2	00061830000	Cover - Switch, Interlock
87	4	01115730000	Screw - Rhms, #6 - 32 x 1 1/4 Phl
88	4	01177246000	Washer - Lock External #6 Zn
89	4	00110128000	Spacer - Unthreaded, .562 Lg
90	2	00061874000	Spacer - Swage, Unthreaded
91	2	00110117000	Plate - Bumper
92	1	00112419000	Harness Assembly - Interlock, Upper
93	1	00112435000	Harness Assembly - Interlock, Lower
94	1	00112372000	Fireshield - Upper, 8.5
95	4	01100242000	Washer - Lock Spring, 5/16
96	4	01182563000	Nut - Hex, 5/16 - 18 Unc - 2b Cad/Zn
98	1	00112370000	Tray - Weight, 8.5 Raised Disp.
99	6	01122027000	Nut - Tinnerman, 1/4 - 20 Type J
100	2	01122233000	Screw - Shcs, 1/4 20 x 3 1/4
101	6	01101930000	Washer - Flat, 1/4 Blk O x Ide
102	1	00110563000	Weight - Test/Calibration
103	1	00112373000	Adapter - Shaft, 8.5
104	4	00062125000	Nutsert - #6 - 32, Autoscan
105	1	00060385000	Nutsert - #10 - 24
113	1	00061231000	Label - Danger, Disconnect Power
114	1	00061316000	Label - Lockout Power
115	6	00111660000	Cable Tie Accessory
120	1	00061278000	Tie - Cable, 11"Lg
121	2	00110305000	Label - Caution, Shaft
122	1	00110319000	Tag - Shaft, Balancer
123	6	01122347000	Cable Tie - Blk, 3 1/4 Lg
124	1	00083048000	Switch - On/Off
125	1	00082820000	Jumper Kit Assembly - Break To Swtc
128	2	00061039000	Connector - Wire, Ideal #74b
134	1	00111626000	Label - Protective Earth
135	1	00112425000	Harness Assembly - Power, Low Volt
136	1	00112426000	Harness Assembly - Power, Hi Volt
137	1	00112436000	Wire Assembly - Ground To Pwr Plug
138	1	00112429000	Receptacle - Plug, Power
139	1	00088872000	Cord - Power, 115v
142	1	00112383000	Support Weldment - Display, 8.5
143	2	00111790000	Clamp, Tower
144	4	01101804000	Nut - Stop, 5/16 - 18 Nylock
145	1	00111399000	Bellow - Cover, Tube
146	4	01111610000	Screw - Hhcs, 5/16 - 18 x 3 Zn
147	1	00112371000	Housing - Display, 8.5
148	1	00112381000	Mount - Display, 8.5
149	1	00112382000	Plate - Mount, 8.5 Display
150	4	01100178000	Bolt - Carriage 1/4 - 20 x 1
151	4	01107381000	Washer - Flat, 1/4 5/8od x 9/32i
152	4	01101609000	Nut - Stop, 1/4 - 20 Unc - 2b Cad
153	1	00112420000	Display Assembly - 8.5
156	4	00111665000	Tubing, Corrugated
157	2	00111763000	Straight Connector, Strain Rel
159	4	01187794000	Screw - Bhcs, 1/4 - 20 x 5/8 Hs
160	4	01122628000	Washer - Nylon, 1/2od x .257id Blk

8.5 Balancer Hood Guard Assembly, P/N 111650

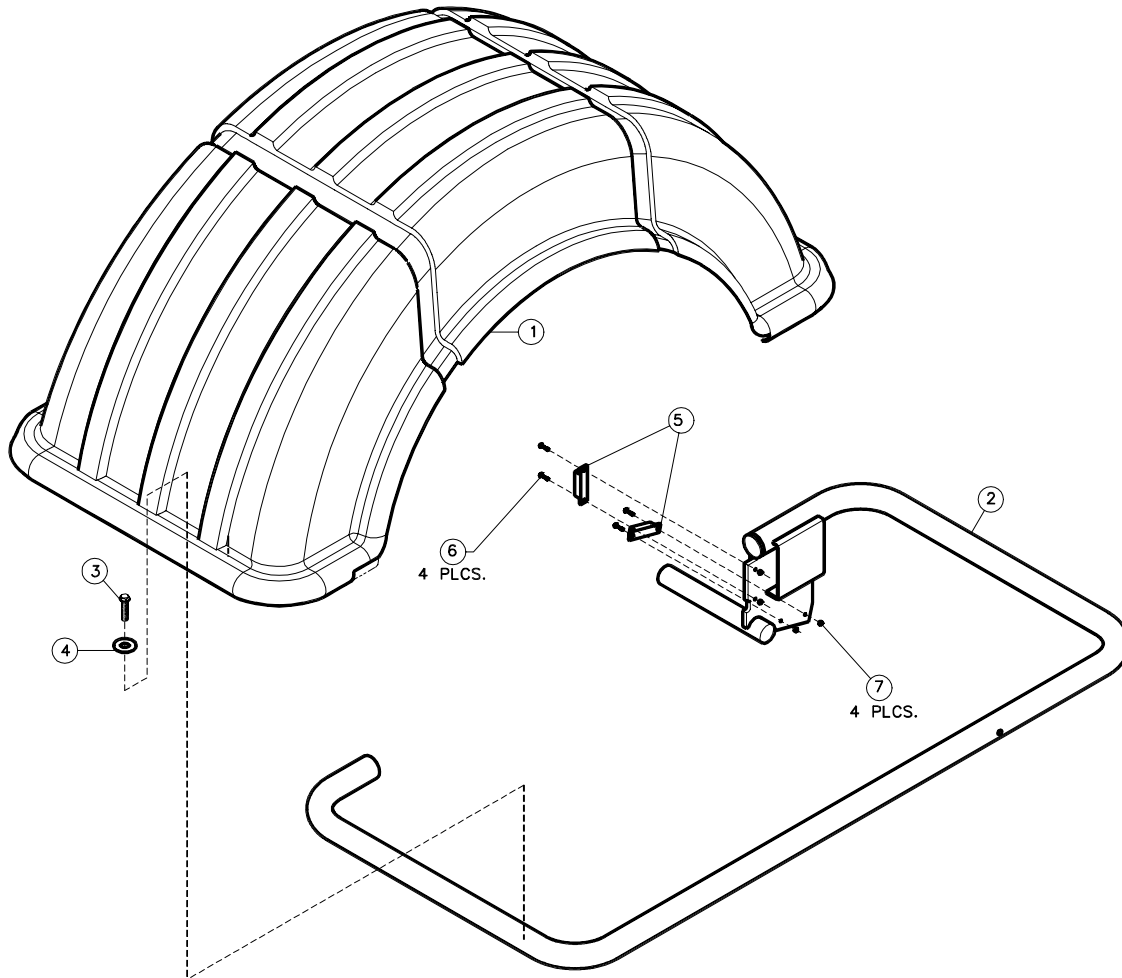

<u>Ref#</u>	<u>Part #</u>	<u>Description</u>
1	00110757000	Wheel Cover
2	00111662000	Wheel Guard Frame Assembly
3	01101710000	Screw - Self Tap, #10 - 24 x 5/8 H
4	00061746000	Washer - Tray, Weight
5	00061829000	Switch - Interlock, Magnetic
6	01115705000	Screw - rhms, #6 - 32 x 5/8 Phl Zn
7	01109764000	Nut - Hex, #6 - 32 Nc-2b
*	00061985000	Label - Warning

\* Not Shown

### 8.5 Balancer Standard Accessories

00112414000 Accessory Pack

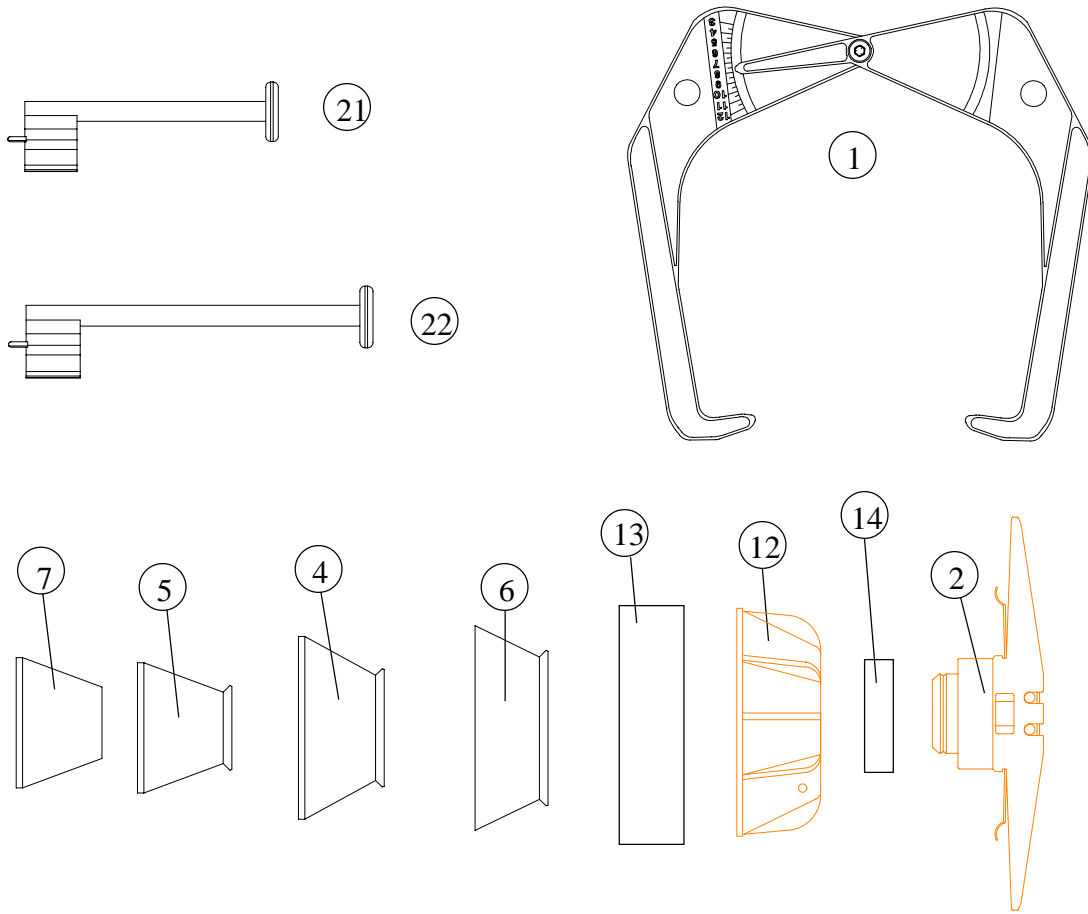

Ref No	Part No.	Req'd No.	Part No.	Description
1	1	1	00061123000	Gauge Assembly - Rim Width
2	1	1	00112298000	Wing Nut Assembly
4	1	1	00061252000	Cone - Large (2.80" to 3.60")
5	1	1	00061253000	Cone - Small (2.180" to 2.98")
6	1	1	00060781000	Cone - Truck, 29 Deg (3.365" to 8.00")
7	1	1	00061476000	Cone - Small (1.66" to 2.54")
12	1	1	00112301000	Large Clamping Hood
13	1	1	00112296000	Ring - Protector
14	1	1	00112300000	Small Clamping Hood
*	1	1	01101794000	Roll Pin - Spring, 5/16 X 1 1/2 - Used to secure wheel guard
*	6	6	00090278000	Hook - Mount, Twin
21	1	1	00112428000	Extension - Distance Gage, 4"
22	1	1	00112430000	Extension - Distance Gage, 6"
*	3	3	00061750000	Stud - Anchor, 1/2 - 13 X 3-3/4

\* Not Shown