

# *geodyna optima*

---

Additional instructions

Wheel balancer

---

**HOFMANN**®





## DISCLAIMER OF WARRANTIES AND LIMITATIONS OF LIABILITIES

While the authors have taken care in the preparation of this manual, nothing contained herein:

- modifies or alters in any way the standard terms and conditions of the purchase, lease or rental agreement under the terms of which the equipment to which this manual relates was acquired,
- increases in any way the liability to the customer or to third parties.

### TO THE READER

While every effort has been made to ensure that the information contained in this manual is correct, complete and up-to date, the right to change any part of this document at any time without prior notice is reserved.

---

**Before installing, maintaining or operating this unit, please read this manual carefully, paying extra attention to the safety warnings and precautions.**

---

All Information in this manual has been supplied by the producer of the equipment:

**Snap-on Equipment GmbH**

Geschäftsbereich Hofmann Werkstatt-Technik

Postfach 1202

D-64311 Pfungstadt

Tel. +49 6157 12-482

Fax +49 6157 12-484

E-mail: [service@hofmann-ge.com](mailto:service@hofmann-ge.com)

Internet [www.hofmann-ge.com](http://www.hofmann-ge.com)

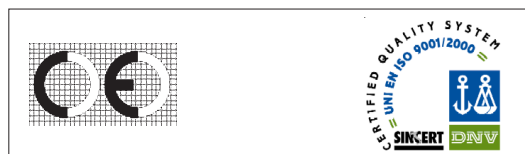

# Contents

1.0	Safety .....	6
1.1	Typographic style .....	6
1.2	Scope of application .....	6
1.3	General safety rules .....	7
1.4	Description of function .....	8
1.4.1	Switching operating modes .....	9
1.4.2	TDI Tread Depth Indication .....	10
1.4.3	Print functions .....	10
8.0	Layout .....	12
9.1	Balancing .....	10
9.1.1	Wheel measuring run in Optima Mode .....	12
9.2	Optima Entry Screen .....	13
9.2.1	Warning Messages in Optima Entry screen .....	14
9.3	Optima Diagnosis .....	16
9.4	Optima Matching .....	17
9.4.1	Geometric Matching .....	17
9.4.2	Geometric matching with only the rim .....	18
9.5	Rim Only Diagnosis .....	18
9.6	Behind-the-spokes placement .....	19
9.7	Advanced Spoke Detection .....	19
9.8	Optima Parameters .....	20
9.9	Print Report .....	21
10.0	Changing modes of operation .....	22
11.0	Optional functions .....	23
11.1	OPTI LINE mode .....	24
11.1.1	PULL calibration .....	30
12.0	Error codes .....	31
13.0	Optimisation / Weight minimisation .....	47
14.0	Readjustment by the operator .....	47
15.0	Maintenance .....	48
15.1	Laser scanners seating glass cleaning .....	48
16.0	Technical data .....	49
17.0	Accessories .....	50
17.1	Printer .....	50
17.2	Wheel elevator .....	50
17.3	Trolley for Flanges .....	50
17.4	Perforated flanges for screw stud .....	50
17.5	SCA Flange .....	50
17.6	Tapered ring .....	51
17.7	Wheel weight removal tool .....	51
18.0	Printer Installation Instructions (optional) .....	52



1-1

## 1.0 Safety

All safety information relative to the unit is described in the Safety Manual (fig. 1-1) supplied alongside this operator's manual.

The safety precautions must be completely understood and observed by every operator. We recommend keeping a copy of the Safety Manual next to the unit within easy reach of the operator.

This manual contains notes and specific warnings for dangerous situations that can occur during the procedures described.

### 1.1 Typographic style

This manual contains specific styles of text that suggest the relative operating modes:

**Note:** provides a suggestion or an explanation.

**WARNING:** NON-OBSERVANCE CAN CAUSE DAMAGES TO THE UNIT OR TO OBJECTS CONNECTED TO IT.

**WARNING:** NON-OBSERVANCE CAN CAUSE INJURY (ALSO SERIOUS) TO THE OPERATOR OR OTHER PEOPLE.

Dotted list:

- Indicates an action or sequence of actions that the operator must carry out in the order set out.

### 1.2 Scope of application

The geodyna 6800 optima balancer is identical to the geodyna 6800 basic model apart from three laser scanners for the automatic detection of the wheel data and the absence of the right detecting arm.

**Note:** the following additional operating instructions integrate, but do not replace, the geodyna 6800 basic manual and the supplement for wheel balancers with Power Clamp device, to which reference must be made for all instructions, operations, notes and warnings. This manual refers to them when required.

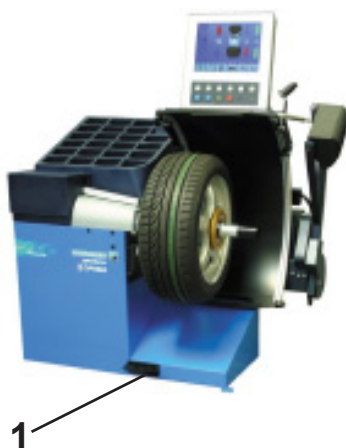

1.2-1

**geodyna 6800 optima model** (figure 1.2-1)

**1** Pedal to operate the Power Clamp and the main shaft lock.

## 1.3 General safety rules

Only properly trained personnel shall be allowed to operate the geodyna 6800 optima balancer.

The machine must be used exclusively for the scope of application by following the operating indications container in the manual.

Unauthorised changes and modifications to the machine relieve the manufacturer from any liability for damages and injuries that might result there from.

On no account should safety features be removed or made inoperative. In general any work on the electrical system, during installation or power supply modifications, must be carried out by a qualified electrician in line with relevant national standards and the regulations of the local power station.

**Note:** Remove jumper X46 prior to insulation resistances tests (500 V DC) and high voltage tests (1000 V AC), in line with EN 60204-1 (see electrical diagram).

It should be noted that working with technical equipment may always involve an unforeseeable acceptable risk. Therefore the operator should eliminate such dangers by operating the machine with care.

The following points should be observed:

- use the machine only as a technical work tool for its specified scope of application only;
- always use original accessories, approved by the manufacturer, in perfect condition and suitable for the type of work to be carried out;
- follow the instructions, notes and technical data of the machine manufacturer and the manufacturer of the wheels to be balanced;
- wear suitable protective clothing and accessories (e.g. goggles, safety shoes, etc.);
- avoid eye contact with the laser scanners;
- do not knock or camper the laser scanners;
- carry out a regular cleaning of the laser scanners glass;
- do not rest on the wheel guard whilst the laser scanner is in operation.

In case of calibration defects there is an internal diagnostic that prompts contacting service.

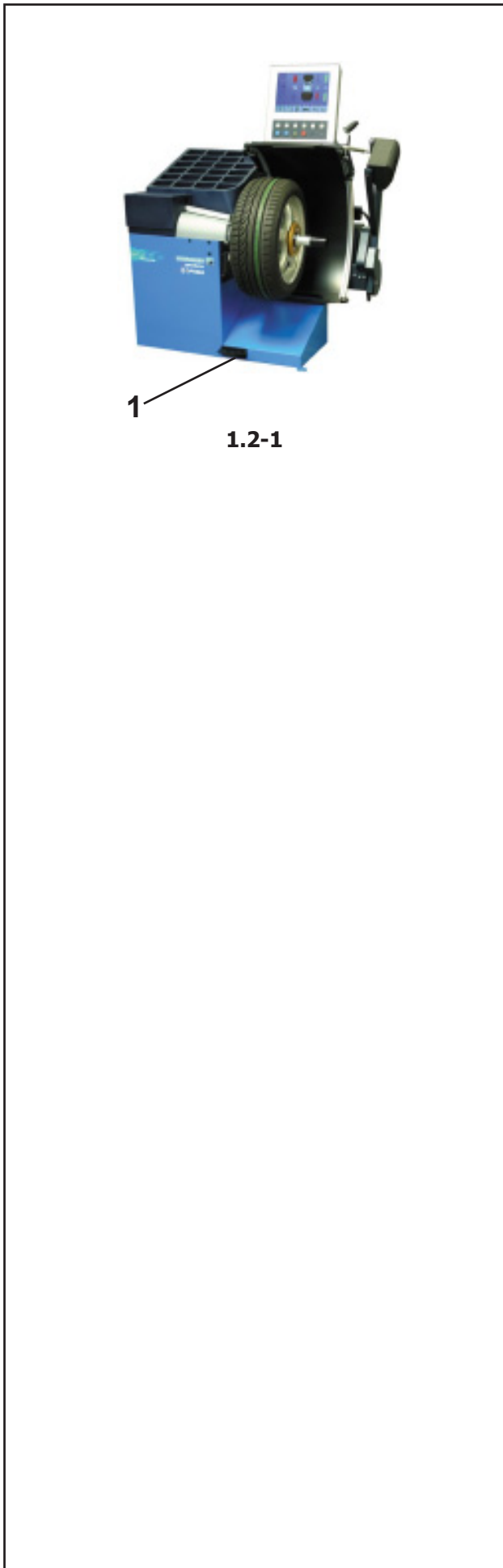

## 1.4 Description of function

The wheel data detection is carried out automatically and with no contact by 3 laser scanners, with integrated CCD. The 6800 optima balancer calculates the co-ordinates of the optimal positions for the application of balancing counter-weights.

The geodyna 6800 optima balancer can be used to determine geometric information relative to rim deformations (deviations of the axis in respect of its rotation axis, commonly referred to as RUNOUT); to determine geometric information relative to tire deformations (deviations of the axis in respect of its rotation axis). This information is useful for an accurate diagnosis of the wheel behaviour as well as providing the operator with useful indications to minimise the effects of these deformations.

The geodyna 6800 optima balancer is able to automatically determine the unbalance of the rim or of the wheel in respect of its rotation centre. At the end of the measuring run the control software carries out a matching, that consists in corresponding the top part of the tire with the bottom part of the rim. The balancer analyses the overall state of the wheel and prompts for any repairs required.

The geodyna 6800 optima balancer carries out two types of **runout**:

- 1) radial (on the radius);
- 2) lateral (on the lateral shift).

The geodyna optima balancer also has the TDI (*Tread Depth Indication*) system, which provides a general indication of tread wear. This function is only active in OPTIMA mode.

The geodyna 6800 optima balancer can operate in three distinct modes:

- a) MANUAL
- b) PROFILING
- c) OPTIMA

### MANUAL

The machine guarantees the basic functions, suggesting the position and value of the weights to apply to the rim. The use is similar to the standard models; balancers fitted only with the left detecting device. The MANUAL mode is activated through the functions menu.

### PROFILING

This mode is identifiable on the monitor with the symbol displayed in fig. 1.4-1 detail 1. The control software automatically acquires the wheel dimensions during the measuring run. During the normal measurement cycle the laser scanner automatically sample the rim shape (internal and external). The machine optically

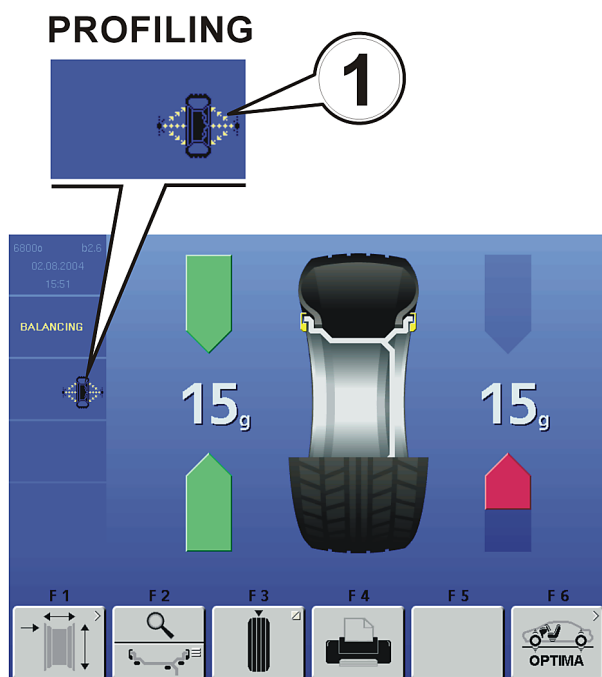

1.4-1

suggests the exact application point of the weight on the rim through the laser beam (laser pointer).

**LASER POINTER:** even if inactive, the Laser Pointer function is present on the optima balancer. The machine is set in geodata arm mode as default. The Laser Pointer mode can be activated by contacting service. For the use of the geodata arm refer to the instructions contained in the geodyna 6800 basic manual.

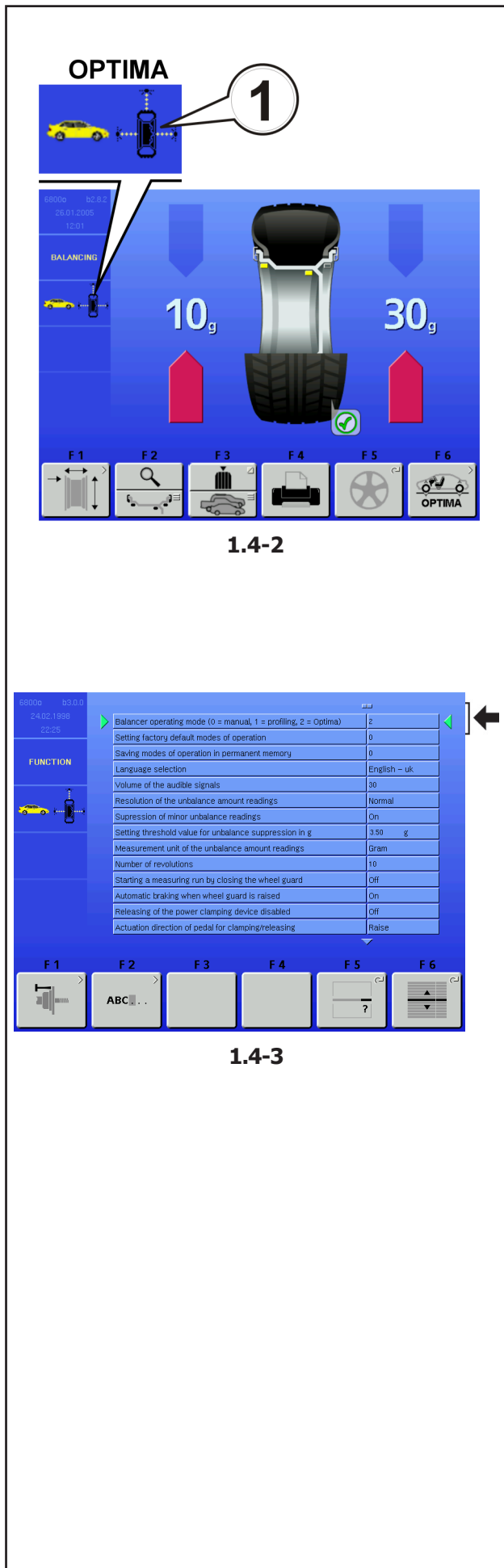

**OPTIMA**

Identifiable on the monitor with the symbol displayed in fig. 1.4-2 detail 1. In this mode the balancer, as well as the **profiling**, carries out the automatic diagnosis of the **runout** and the reading for the TDI function.

**Control of the rim only:** in OPTIMA mode, clamping only the rim on the balancer, the laser scanner detects the absence of the tire. In this condition, the rear laser analyses the **runout** on the bead recess in the internal part of the rim and will prompt to automatically proceed with the **matching**.

**1.4.1 Switching operating modes**

(fig. 1.4-3)

The balancer can be set so that it presents the desired mode of operation at power-on.

- Set the desired value in the functions menu:

- 0 - MANUAL;
- 1 - PROFILING;
- 2 - OPTIMA.

Keep the F6 key pressed to switch from Profiling to Optima and vice versa.

**Note:** refer to the geodyna 6800 basic manual for the navigation procedure through the function menus and personal data entry modalities.



## 1.4.2 TDI Tread Depth Indication

When run in OPTIMA mode, the machine always automatically detects the depth of the tread groove at the centre of the tire and over its whole circumference.

According to the mean value detected and the limit value set, the program displays one of the following Tread Groove indications on screen (Fig. 1.4.2-1):

- a) GREEN icon = higher than limit set.
- b) YELLOW icon = close to limit.
- c) RED icon = below limit set.

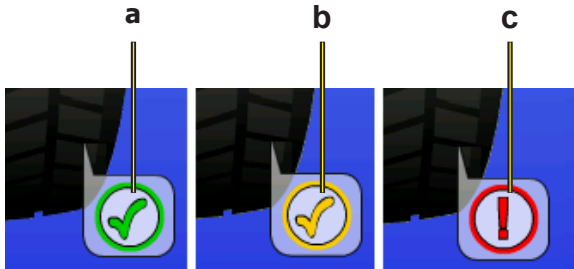

1.4.2-1

**Note:** The information provided for the operator is intended as a guideline only. The TDI function is designed to alert the operator to the need for a closer examination of wear on the tread.

The operator can set the tread depth limit value for which wear information will appear on screen. To change the limit value go to the “Optima Operating Parameters” menu (Section 9.7).

## 1.4.3 Print functions

The FUNCTION screen page includes three print settings items:

**Printing.** Field for switching the printer On/Off. Set to On to enable printing. Set to Off to disable printing.

**Paper size.** Field for selecting the print format. Activate the format which matches the paper size used, A4 or *Letter*.

**Printer type.** Field for selecting the type of connection to the machine PC.

- **0** activates the connection via parallel port.
- **1** activates the connection via USB port.
- **2** sets the machine up for a special connection, reserved for technicians.

## **2.0 Installation**

See geodyna 6800 basic model instructions.

## **3.0 Electrical connection**

See geodyna 6800 basic model instructions.

## **4.0 Controls and displays**

See geodyna 6800 basic model instructions.

## **5.0 Starting the machine**

See geodyna 6800 basic model instructions.

## **6.0 Clamping the wheel**

See geodyna 6800 basic model instructions and the supplement for wheel balancers with Power Clamp device.

## **7.0 Entry of wheel type, balancing mode and wheel size**

In Profiling and Optima mode the wheel data entry is automatic (see later instructions).  
For Manual mode functioning see geodyna 6800 basic model instructions.

## 8.0 Layout

The geodyna optima balancer is fitted with a laser scanner (fig. 8-1, details 1, 2 and 3) for the automatic measurement of the wheel data.

The internal laser scanner (detail 1) carries out the following measurements:

- a) detects the internal profile of the rim to identify the optimum position of the weight to apply on the left part or internal part of the rim;
- b) calculates the distance and diameter of the rim;
- c) detects the left outer radial and lateral runout;
- d) detects the number and position of any spokes.

The laser scanner integrated on the wheel protection guard (detail 2), carries out the following measurements:

- a) automatically calculates the best point for the application of the weight on the external part of the rim;
- b) detects the right lateral and radial runout;
- c) detects the width of the rim.

The rear laser scanner (detail 3) carries out the following measurements:

- a) detects the tread runout, or the runout of only the rim on the bead recess.

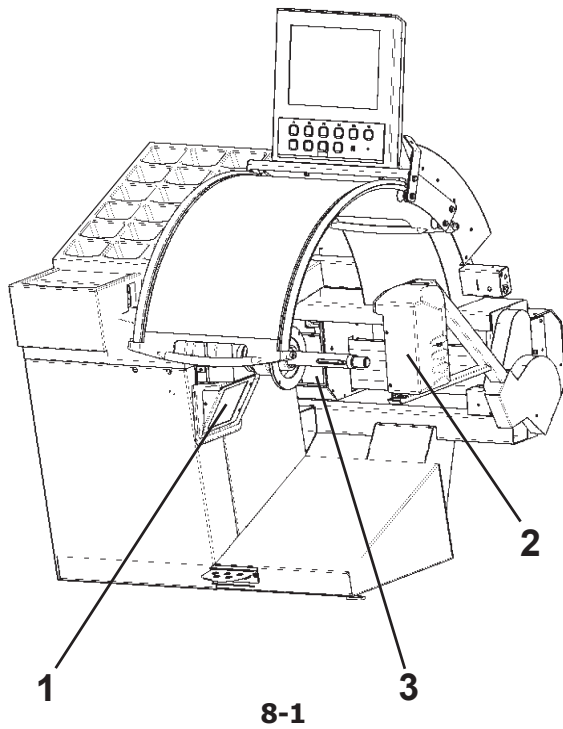

## 9.0 Optima BALANCING

The geodyna optima balancer is fitted with 3 laser scanners with integrated CCD that guarantee an accurate detection of the characteristics of any type of wheel. The laser scanners carry out a series of geometric measurements on the rim, the tread, the flange and the profile of the rim and of the whole wheel with a single measuring run of a few seconds. The measurements detected are then interpreted by the integrated pc that provides detailed comparative evidence with a geometric comparison aimed at improving the wheel efficiency and can print an exhaustive diagnostic report.

**Note:** the following instructions describe the specific functions of the geodyna 6800 optima wheel balancer in OPTIMA mode. For operations different from the ones described refer to the manual for the geodyna 6800 basic model.

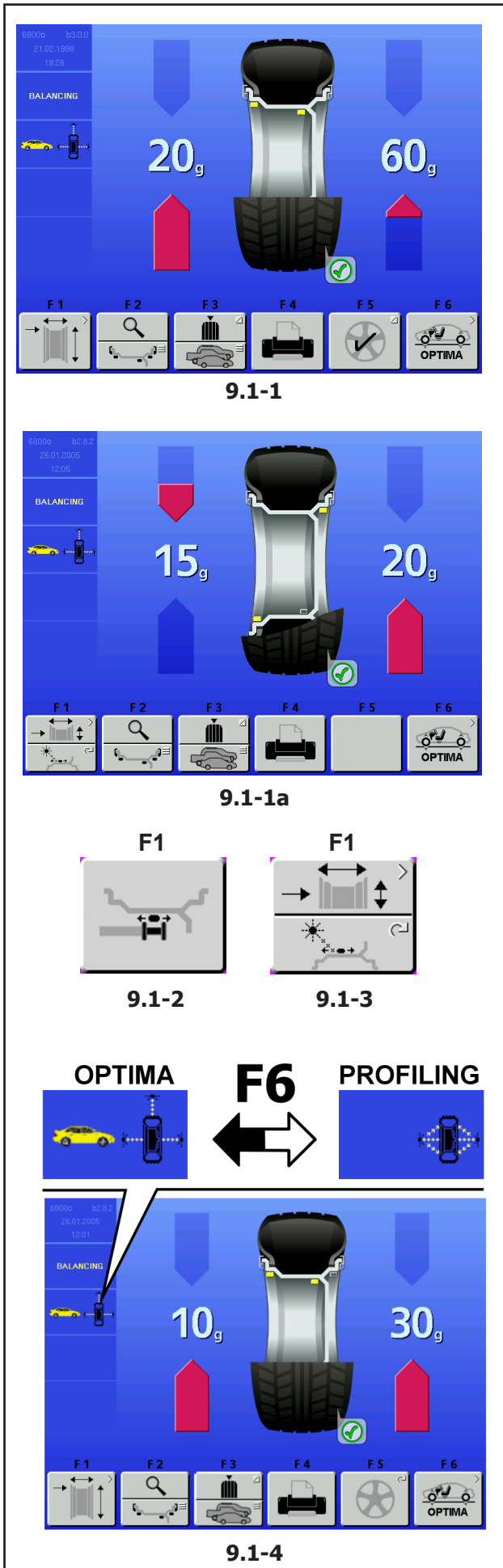

9.1-1

9.1-1a

9.1-2

9.1-3

9.1-4

### 9.1 Balancing

The balancer displays the start screen at power-on (see geodyna 6800 basic model generic instructions).

The screen in fig. 9.1-1 appears automatically on the monitor after clamping the wheel or by pressing F4 from the start screen. Keep the F6 key pressed to select the Optima or the Profiling mode (fig. 9.1-4).

**Note:** If the *Laser Pointer* mode was activated instead of the *geodata* system, the balancing screen appears as shown in fig. 9.1-1a.

**Note:** With the *Laser Pointer* mode switched on, the image is a true representation of the actual location of the adhesive weights. A larger rim cross-section shows the weights suggested (yellow) or possible alternatives (grey) in the 6 o'clock zone, precisely where the laser beam indicates they should be applied.

**F1:** to access the rim nominal dimensions screen. With ALU mode selected, when the geodata arm is removed, key F1 changes icon (fig. 9.1-2), allowing relocation of the weight in a different position to the one suggested.

In contrast, with Laser Pointer mode active the key appears split in two (fig. 9.1-3): hold down the lower part of the key and turn the wheel manually to vary the position of the weight indicated by the pointer. In both cases, changing the position varies the value of the weight. Changing position is possible on both wheel planes. When you change the position of the weight on one side of the wheel the value of the weight on the opposite plane turns red to indicate the change of value and/or angular position.

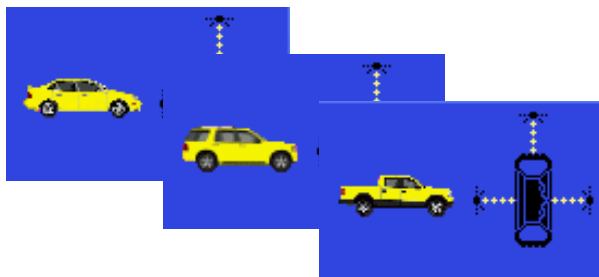

9.1-5

**Note:** The change in the position of the weight is saved by the machine, then automatically suggested for all subsequent wheels with the same dimensions. The selection is deleted when the machine is switched off.

**F2:** the top part of the key is described in the geodyna 6800 basic model instructions. The bottom part of the key changes the weights application mode. The normal mode is accessed by pressing the key for longer (clip balance weights).

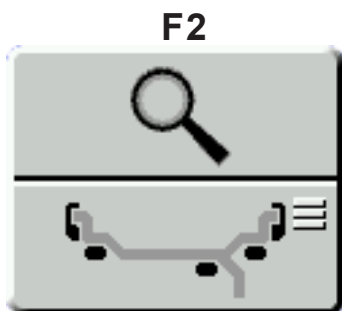

**Note:** The possible application of the weights in ways other than that suggested by the machine is indicated by the grey weights in the positions compatible with the rim configuration detected.

**Note:** The change in the weight application mode is then automatically suggested for all wheels with the same dimensions, until the machine is switched off.

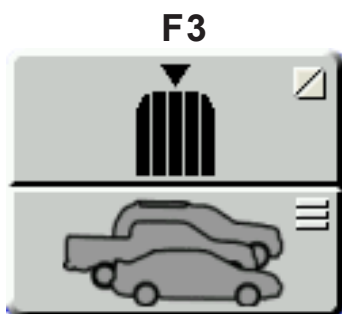

**F3:** The upper part of the key is described in the geodyna 6800 basic model manual.

Use the lower part of the key to select the Vehicle Type to be operated on. There are three vehicle types selectable (fig. 9.1-5): CAR, SUV, TRUCK, with runout limits suitable for the class of vehicle set for each. The limit values assigned separately to each Vehicle Type are:

- First harmonic Wheel radial Runout,
- Peak to Peak Wheel radial Runout and
- Tread Depth.

The values can be changed individually and saved by the user in the "OPTIMA PARAMETERS" menu.

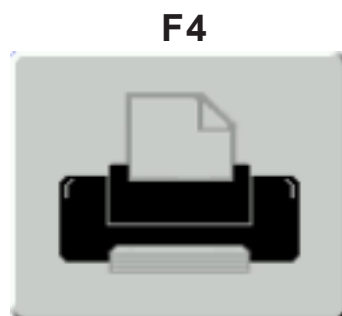

**F4:** prints the diagnostic report (the printer must be active). Pressed again it interrupts the current print (in this case the key will be blocked).

**F5:** activates the mode on the spokes. For a correct detection the spokes on the rim must be equidistant, of a regular shape and of a minimum number of 3 and maximum number of 12. If the number of spokes has been detected correctly, a check mark will appear on the relative key (fig. 9.1-6). If the spokes cannot be detected, the pictorial as shown in Fig 9.1-7 is displayed. Pressing F5 will display the values of the two separate weights to apply on the wheel. Therefore it will not be necessary to introduce the reference spoke location data as it has already been detected by the control software. Proceed directly with the application of the wheel weights. To exit the Spoke mode, press F5 once again or remove the wheel.



9.1-6



9.1-7



If the laser scanners have not been able to detect the spokes or estimate their location, even if the type of wheel has been correctly identified, activate the Advanced Spoke Detection function (Section 10.1) in the OPTIMA PARAMETERS screen and repeat the wheel run. In any event, the data with the number of spokes and their position can be nevertheless introduced manually

Proceed as follows:

- Keep F5 pressed and contemporaneously manually rotate the wheel.
- Release F5 when the correct number of spokes is displayed on the monitor.
- Manually rotate the wheel in order to align one of the spokes at 12 o'clock.
- Press F5, the control software carries out the calculation and displays the two weight values, appropriately divided.
- Fit the weights to the wheel, behind the spokes, as shown on the monitor.

**F6:** keeping it pressed changes the mode from Profiling to Optima. Pressed briefly it accesses the OPTIMA ENTRY Screen.

### 9.1.1 Wheel measuring run in OPTIMA Mode

- Lower the covering guard. If the automatic measuring run function has not been activated, press the START key: the balancer carries out the wheel measuring run piloted by the laser scanners. They detect the rim profile; measure the wheel runout; the internal rim lateral and radial and the external rim lateral and radial.

At the end of the wheel measuring run the balancer displays any unbalance on the wheel and signals the points to fit the weights, unless the RUNOUT limits have not been exceeded, in this case the balancer automatically suggests the OPTIMA ENTRY procedure.

Press F1 to display the wheel (rim + tire) size data detected with the wheel measuring run.

Press F2 to alternate the characteristics of the weights (ALU or adhesive): the balancer will automatically recalculate the value and position of the corresponding weights.

The wheel measuring run may have detected the number of spokes: in this case press F5 to determine the position of the hidden weights.

## 9.2 OPTIMA ENTRY Screen

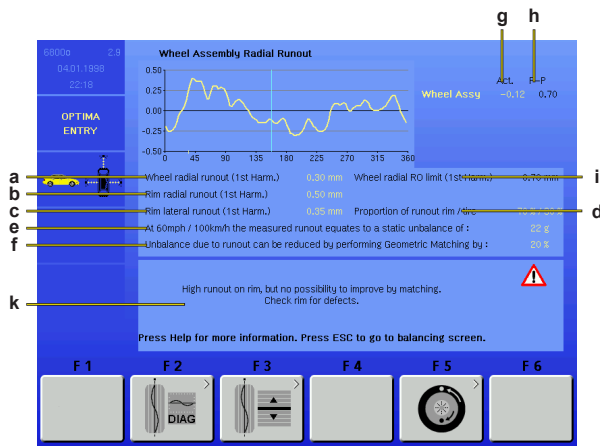

9.2-0

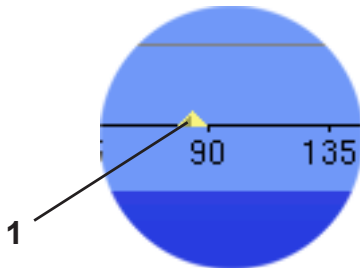

9.2-1

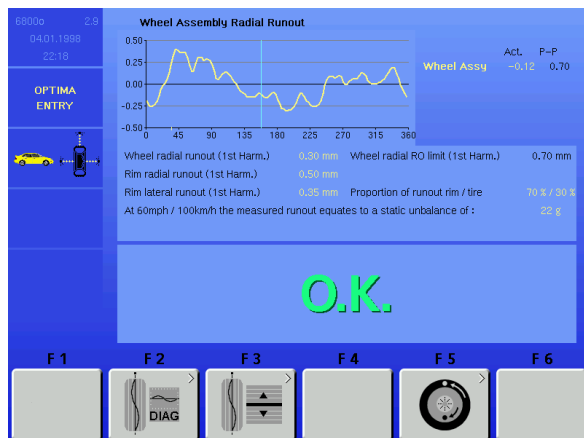

9.2-2

(fig. 9.2-0)

Press **F6** in the balancing screen to access.

The control software automatically displays this screen whenever, at the end of the wheel measuring run, the measuring values exceed the preset limits.

The overall wheel (rim + tire) measuring run is displayed. To move the cursor on the wheel graph, rotate the wheel by hand in both directions.

All of the OPTIMA ENTRY screens show the first harmonic Peak index (1, fig. 9.2-1), which facilitates advanced diagnosis of the rim or the wheel.

The unbalance data is shown under the graph (first runout harmonic).

The automatic Position Brake fitted on the machine will be activated when the peak position is manually brought to the 12 o'clock point.

The Position Brake function can be temporarily disabled in two ways:

- In the BALANCING or OPTIMA ENTRY screens press the STOP key once to disable, press it a second time to re-enable the function.
- The brake is not activated if the "Rim Cleaning Position Brake Control" function has been activated in the FUNCTIONS menu.

- a) Wheel radial runout.
- b) Rim radial runout (if measured).
- c) Rim lateral runout (if measured).
- d) Runout proportion due to rim or tire.
- e) Equivalent static unbalance estimate given by the runout at 100 km/h.
- f) Describes the performance improvement if the geometric matching is applied.
- g) Runout value at the position the graph cursor is in, which corresponds to the wheel at 12 o'clock.
- h) Peak to peak (p-p) graph; the peak to peak value is the difference between the maximum and minimum value.
- i) Preset threshold on the wheel runout.
- k) Warning of defective rim and/or tire. The software prompts the operator to check for rim or tire defects, suggesting *matching* or automatically showing the screen for the appropriate corrective action, where necessary.

If defects are found, box "j" may display from one to three Warning Messages (Section 9.2.1). Each message may indicate two levels of seriousness, as follows:

For measurements above the limit value, a Problem indication is displayed.

For measurements straddling the limit value, the Possible Problem indication is displayed.

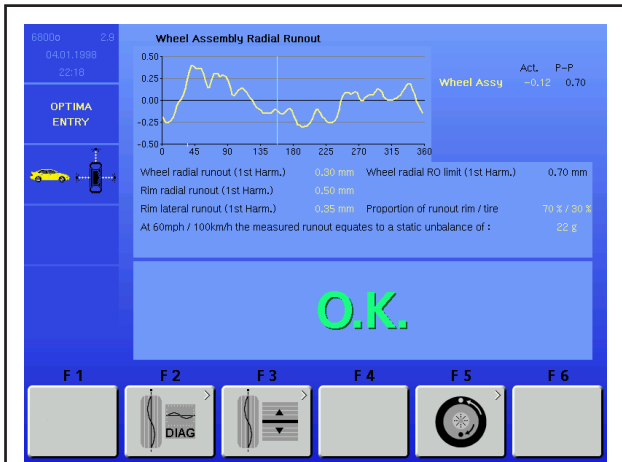

9.2-2

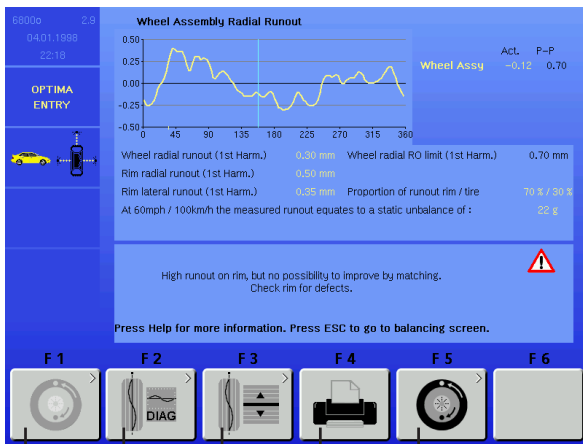

9.2-3

F1 F2 F3 F4 F5



9.2.1-1

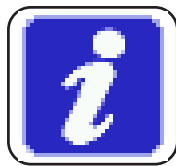

9.2.1-2

If no problems are found with the wheel, tire or rim, the OPTIMA ENTRY screen page shows "OK" (Fig. 9.2-2).

The appearance of the messages is linked to the limit values set, which the operator can change using the OPTIMA PARAMETERS menu (Section 9.6).

(fig. 9.2-3)

**F1:** restarts an interrupted matching procedure.

**F2:** displays the screen for the advanced rim diagnosis (see "OPTIMA DIAGNOSIS" section).

**F3:** access the preset work parameters in Optima mode (see "OPTIMA PARAMETERS" section).

**F4:** print (if printer is available) or interrupts the current print (in this case the key is blocked).

**F5:** opens the "OPTIMA MATCHING" screen.

## 9.2.1 Warning Messages in OPTIMA ENTRY screen

**Wheel assembly problems** messages appear when:

- 1) wheel peak-to-peak *runout* is high
- or
- 2) wheel 1-harmonic *runout* is high and the proportion of *runout* between rim and tire is close to 50 per cent.

**Alert Message** (Fig. 9.2.1-1):

If no *matching* is recommended:

High *runout* on wheel, but no possibility of improving by *matching*. Check rim and tire for defects.

If *matching* is recommended:

High *runout* on wheel. Geometric *matching* is recommended.

**Warning Message** (Fig. 9.2.1-2):

Possible issue with wheel, but no possibility of improving by *matching*. Check rim and tire for defects.

If *matching* is recommended:

Potential problem on the wheel. Check rim and tire for defects.



**Rim problems** messages appear when:

- 1) rim radial *runout* is high  
or
- 2) rim lateral *runout* is high  
or
- 3) wheel 1-harmonic *runout* is high and the proportion of *runout* between rim and tire is greater than 60 per cent (high rim 1-harmonic *runout*).

**Alert Message**

If no *matching* is recommended:

High *runout* on rim, but no possibility of improving by *matching*. Check rim for defects.

If *matching* is recommended:

High *runout* on rim. Geometric *matching* is recommended.

**Warning Message**

Possible issue with rim, but no possibility of improving by *matching*. Check rim for defects.

If *matching* is recommended:

Potential problem on the rim. Check rim for defects.

**Tire problems** messages appear when:

- 1) wheel 1-harmonic *runout* is high and the proportion of *runout* between rim and tire is less than 40 per cent (low rim 1-harmonic *runout*)

**Alert Message**

If no *matching* is recommended:

High *runout* on tire, but no possibility of improving by *matching*. Check tire for defects.

If *matching* recommended:

High *runout* on tire. Geometric *matching* is recommended.

**Warning Message**

Possible issue with tire, but no possibility of improving by *matching*. Check tire for defects.

If *matching* is recommended:

Potential problem on the tire. Check tire for defects.

The last line of the warning box is:

Press HELP for more information. Press ESC to return to balancing screen.

## 9.3 Optima Diagnosis

### Advanced diagnostics data

(fig. 9.3-1)

The top graph shows the wheel runout. The lower graph shows the rim radial runout.

**F3:** to change from this screen to the following one (see “Rim radial and lateral runout” section).

### Rim radial and lateral runout

(fig. 9.3-2)

The screen page shows the rim radial and lateral runout graphs.

**F3:** to change from this screen to the previous one.

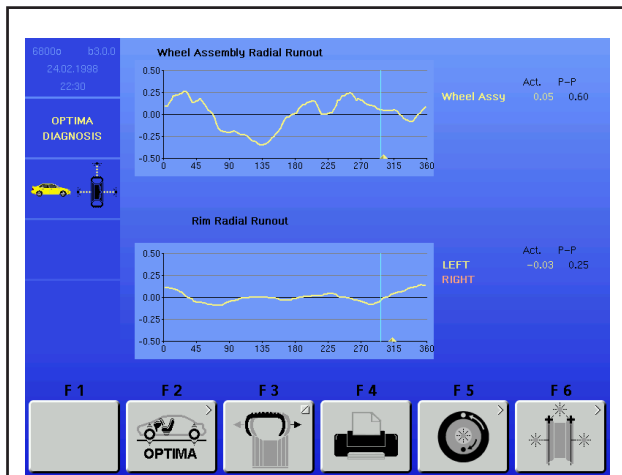

**9.3-1**

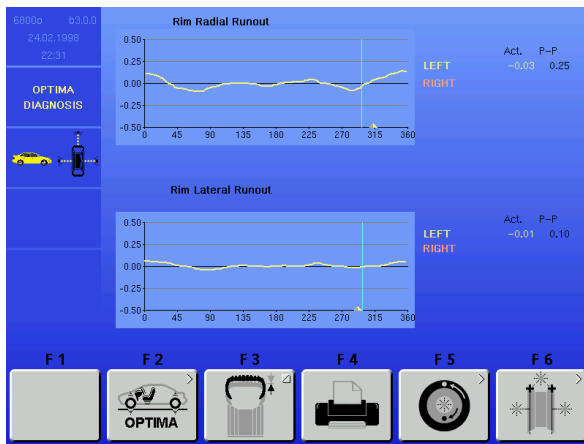

**9.3-2**

## 9.4 OPTIMA MATCHING

There are two ways to access the Matching procedure:

1) Manually,

- Press **F5** in the "OPTIMA ENTRY" screen (fig. 9.4-1) to go to the "Optima Matching" screen (fig. 9.4-2).
- From "OPTIMA MATCHING" continue by pressing
  - **F2** Continues the interrupted Matching.
  - **F5** Matching from complete wheel.
  - **F6** Matching from rim only.

2) Automatically,

by observing the following conditions:

- RIM ONLY function OFF ("0" for RIM ONLY item in "OPTIMA PARAMETER" screen).
- Perform the rim only run.

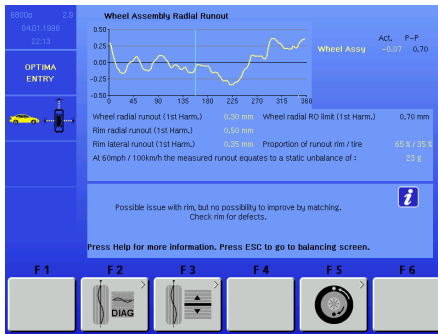

9.4-1

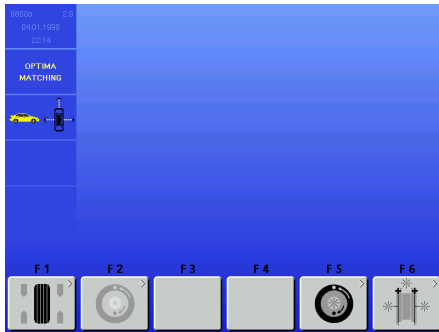

9.4-2



9.4.1-1

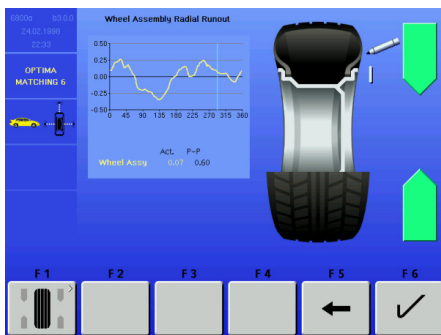

9.4.1-2



9.4.1-3

### 9.4.1 Geometric Matching

(fig. 9.4-2)

At the end of the wheel measuring run the balancer may prompt carrying out a geometric matching (F5 key highlighted in the "Optima Matching" screen), whose diagnosis can provide a substantial improvement to the wheel performance. To start the geometric matching procedure proceed as follows:

- Press F5 on the "Optima Matching" screen to start the procedure. The control software prompts to position the wheel valve at 12 o'clock (fig. 9.4.1-1).
- Press F6 to confirm the operation.
- Mark the tire in the position suggested by the control software (fig. 9.4.1-2) and press F6 to confirm. The control software suggests moving the tire to the tire changer in order to align the mark on the tire with the wheel valve (fig. 9.4.1-3).
- After the tire changer, clamp the wheel on the balancer and confirm with F6. The control software prompts to carry out a checking cycle. (Press F4 to carry out a checking cycle of the runout directly).
- Lower the wheel guard and press START: the balancer will start the checking cycle.

At the end of the checking cycle the control software will suggest the new value of the weights and their location on the rim.

During the geometric matching procedure you can return step by step to the previous screens by pressing F5. Pressing F1 displays the balancing screen; press the ESC or STOP keys to return to the "Optima Matching" screen; from this last press F1 to continue the previously interrupted geometric matching procedure.

## 9.4.2 Geometric matching with only the rim

(fig. 9.4.2-0)

- After having clamped the rim to analyse on the balancer, press F6 on the "OPTIMA MATCHING" screen.
- Lower the wheel guard and press the START key: the laser scanners carry out the runout measurement in the bead seats. At the end of the measurement the control software prompts the alignment of the rim valve at 12 o'clock (fig. 9.4.2-1).
- Press F6 to confirm.
- Release the rim and move it to the tire changer to fit the tire (fig. 9.4.2-2).
- After the tire changer, clamp the wheel (rim + tire) on the balancer and confirm with F6.
- Lower the wheel guard and press START: the balancer will proceed with the runout calculation with the tire fitted.

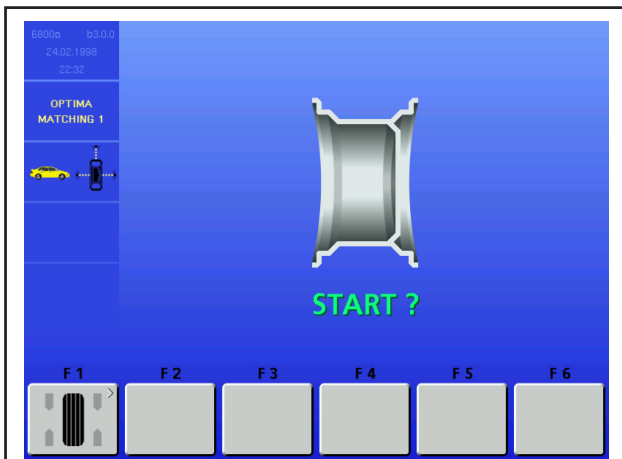

9.4.2-0

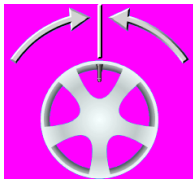

9.4.2-1

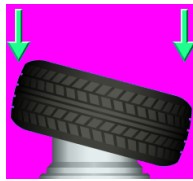

9.4.2-2

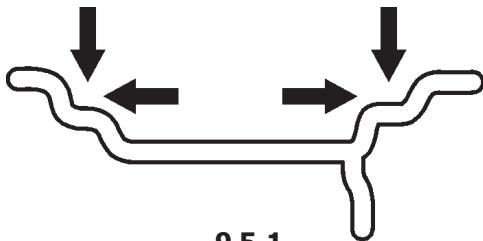

9.5-1

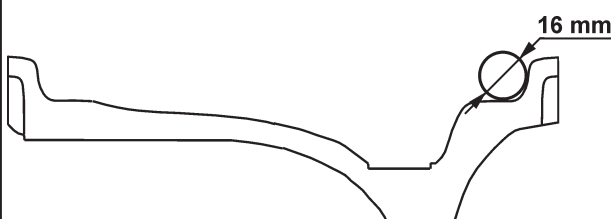

9.5-2

To carry out the geometric matching of the complete wheel proceed as indicated in the "Geometric matching" section.

## 9.5 Rim Only Diagnosis

Optima can be used to perform an analysis of the rim only and to process its structural parameters, independently of the tire.

If only the rim is clamped, the machine always automatically recognises the presence of a rim without the tire.

To activate the "Rim only diagnosis" function:

- enable "1" in the "Optima Parameters" screen at the "RIM ONLY" item (m, Section 9.6).
- start the run.

During the run measurements are taken on the lateral internal profiles and on the bead recesses (fig. 9.5-1). The laser reading positions on the rim are the same as the contact points obtained with a circle with 16mm diameter, as shown in figure 9.5-2.

When the run is complete, the graph showing the curves for the radial Run-out of the right and left bead recesses appears (fig. 9.5-3).

Only in the RIM ONLY function, the graph shows three different coloured markers, indicating the first harmonic peak position for:

Left bead recess - Yellow triangle

Right bead recess - Red triangle

Mean of the entire rim - Grey triangle

When the rim is turned, it will be stopped by the brake in each peak position, to facilitate rim marking. The

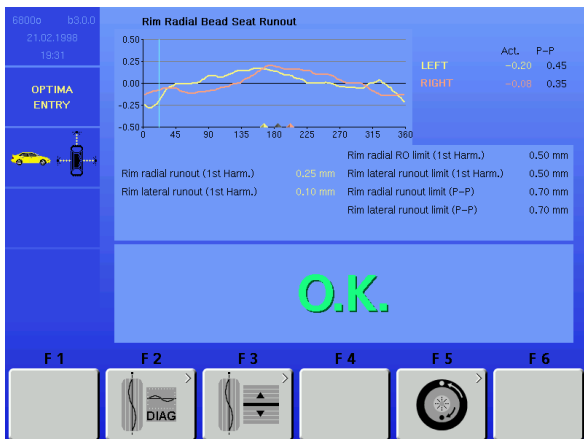

9.5-3

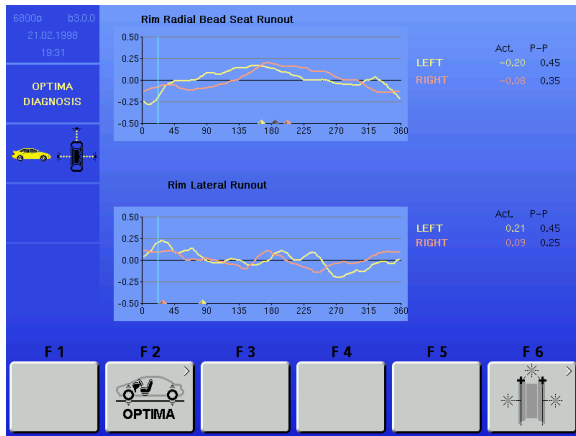

9.5-4

peak markings on the rim can then be suitably combined with the minimum reference present on the tyre.

- press **F2** for further information about the rim Runout (Fig. 9.5-4).

These graphs also show the first harmonic peak markers, combined with the Position Brake.

The "RIM ONLY" diagnosis uses specific limit values, irrespective of those used for the whole wheel. The factory values set are:

First harmonic Radial/Lateral Runout = 0.5

Peak to Peak Radial/Lateral Runout = 0.7.

The values can be changed by the user in the "OPTIMA PARAMETERS" menu.

**Note:** Activating the "RIM ONLY" function also allows a specific printed report to be obtained (if optional printer is present) for the rim only "**Rim diagnostic report**" (see Section 9.7).

**Note:** The function lengthens the measuring cycle to a total of 55 seconds.



9.7-1

## 9.6 Behind-the-spokes placement

See geodyna 6800 basic model instructions and F5 key description in section 9.1.

## 9.7 Advanced Spoke Detection

This mode, which can be activated when required, allows absolute precision when detecting the position and dimensions of the rim spokes, to allow more precise behind the spokes placement. If the laser scanners can't recognise the spokes or the operator decides he is dealing with a rim with a particularly complex shape, enable the Advanced Spoke Detection function which recognises any type of spokes, even those with unusual

shapes, for example: paired, oblique, with holes or of different sizes to one another (fig. 10.1-1). Before performing the measuring run:

- From the OPTIMA PARAMETERS screen select 1 next to the "Advanced Spoke Detection" item.

- Perform the normal procedures for the run.

**Note:** This function increases the time for the total measuring cycle by 5 seconds

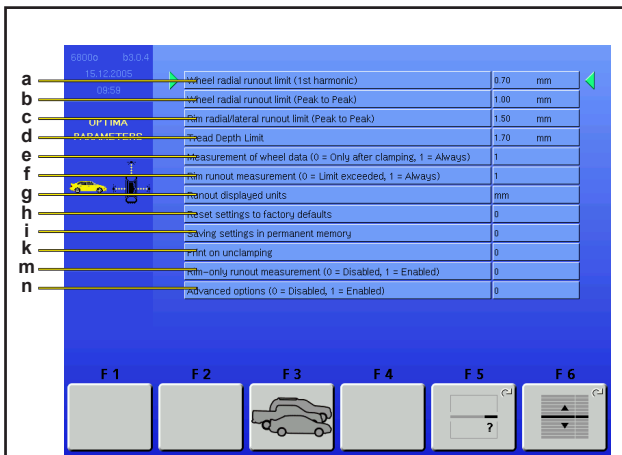

9.8-1

## 9.8 OPTIMA PARAMETERS

(fig. 9.6-1)

**F5** and **F6** have the same meaning of the screen relative to the geodyna 6800 basic model.

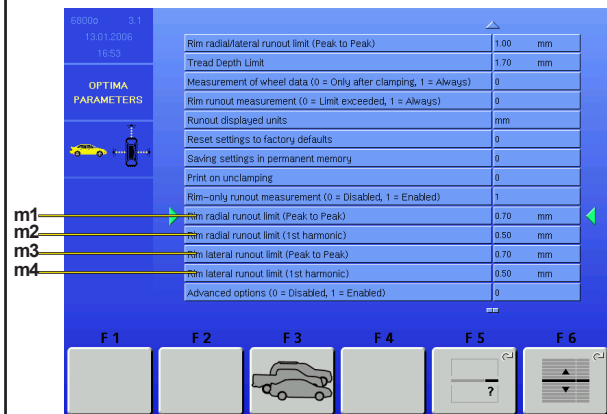

9.8-2

- Limit (threshold) for wheel first harmonic radial runout. Preset value: 0.7 mm.
- Limit (threshold) for wheel peak to peak radial runout. Preset value: 1,5 mm.
- Limit (threshold) for peak to peak radial/lateral runout of rim only. Preset value: 1 mm.
- Set the limit value for the Tread Depth TDI. The scale is 0 to 10 mm (0-0,400 inche). Set the value 0 or "0,00" to disable the function; no icon appears on screen. Preset value: 1,7 mm (0,068 inche).
- The wheel data detection scan occurs always during the first measuring run. This function allows the exclusion of the activation of the laser scanner in the following measuring runs, in order to optimise the operating times whenever it is necessary to carry out more than one measuring run for the same wheel. By assigning value "0" the scan occurs automatically and only at the first measuring run, after fixing the wheel. By assigning value "1" the scan occurs automatically at every wheel measuring run (Preset value).
- Sets the rim runout measurement (if the value is 0 the measurement occurs only if the threshold is exceeded; if the value is 1 the measurement occurs always). Preset value: 0.
- Runout measurement unit selection in mm or inches. Preset value: mm.
- Reset the preset default values.
- Saves the values set by the operator.
- Automatically prints when the wheel is removed (only if the printer is present and active). If the value is "0" (preset) it doesn't print, if the value is "1" it prints.
- Allows selection of RIM ONLY advanced diagnosis. Select "1" = Enables RIM ONLY advanced diagnosis and opens the screen shown in fig. 9.6-2.

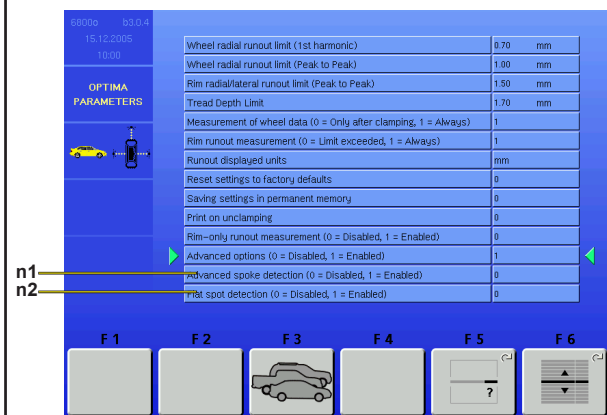

9.8-3

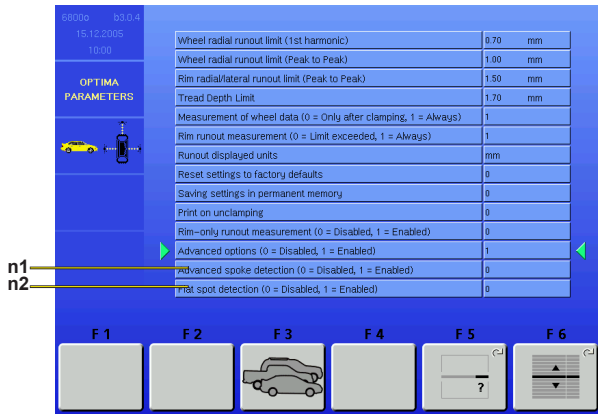

9.8-3

Select "0" = Enables automatic switching to the MATCHING procedure if the machine detects the presence of the rim only (fig. 9.6-2).

- m1) Limit (threshold) for RIM ONLY peak to peak radial Runout. Preset value: 0.7 mm.
- m2) Limit (threshold) for RIM ONLY first harmonic radial Runout. Preset value: 0.5 mm.
- m3) Limit (threshold) for RIM ONLY peak to peak lateral Runout. Preset value: 0.7 mm.
- m4) Limit (threshold) for RIM ONLY first harmonic lateral Runout. Preset value: 0.5 mm.
- n) ADVANCED OPTIONS 1 and 2 (fig. 9.6-3).
  - "1" = Enables additional fields for managing advanced features.
- n1) Advanced Spoke Detection, activated in the OPTIMA PARAMETERS menu, useful if the rim has complex spokes that are difficult to identify.
  - "1" = Enables function. "0" = Disables function.

## 9.9 Print Report

The report print out (only possible with the optional printer) is a summary of technical information. The information saved during rim or rim and tire analysis can be printed on paper in a sheet called a Report. There are two types of Report, automatically selected by the machine:

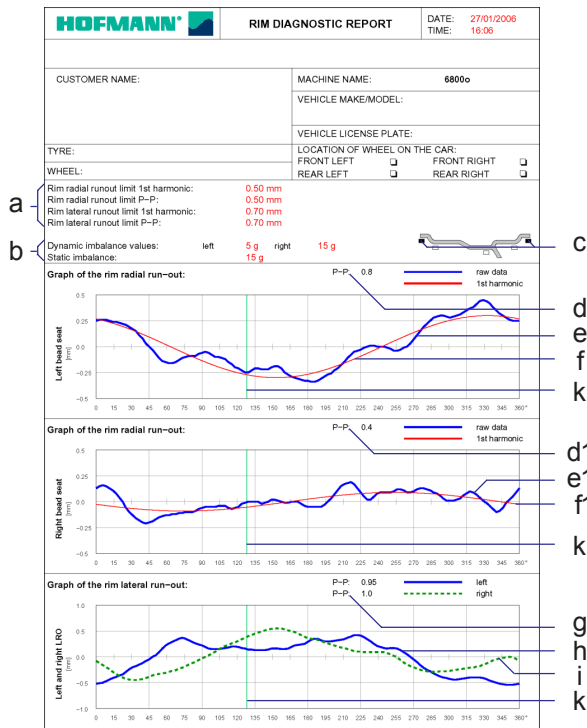

9.9-1

### - Rim diagnostic report

The report print out, after a rim only run, shows the following information:

- (fig. 9.7-1)
- a) Dynamic unbalance (right and left). Static unbalance.
- b) Limits (thresholds) for first harmonic and peak to peak (radial/lateral) rim runout.
- c) Suggested position for application of weights.
- d) Left bead recess runout peak to peak value.
- e) Graph of left bead recess runout (blue curve).
- f) Graph of left bead recess first harmonic (red curve).
- d1) Right bead recess runout peak to peak value.
- e1) Graph of right bead recess runout (blue curve).
- f1) Graph of right bead recess first harmonic (red curve).
- g) Rim lateral runout peak to peak values (left and right).
- h) Graph of rim left lateral runout (blue curve).
- i) Graph of rim right lateral runout (dashed green curve).
- k) Rim 12 o'clock position indicator at moment of printing (green line).

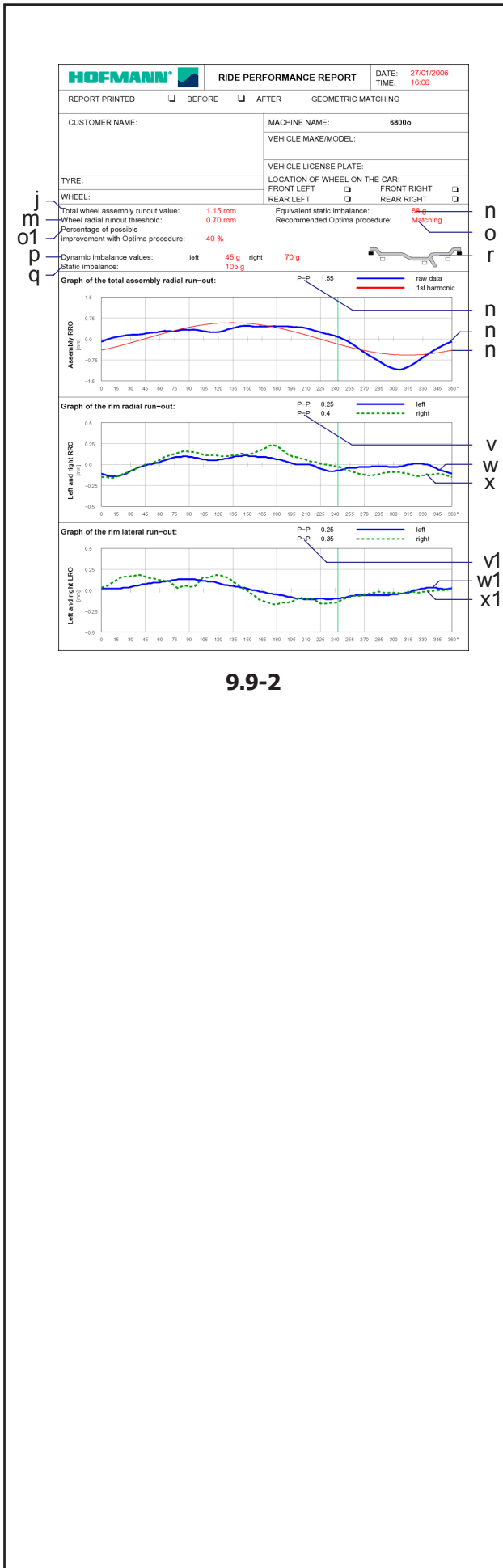

**- Wheel performance report**

The report print out, after a complete wheel run, shows the following information:

(fig. 9.7-2)

- j) Rim - tire assembly total runout value.
- m) Wheel radial runout threshold value.
- n) Equivalent Static Unbalance, induced by Runout measured.
- o) Recommended Optima procedure.
- o1) Percentage improvement which can be achieved using recommended Optima procedure.
- p) Dynamic Unbalance measured (right and left).
- q) Static Unbalance calculated from dynamic components measured.
- r) Suggested position for application of weights.
- s) Complete wheel radial runout peak to peak value.
- t) Graph of complete wheel radial runout (blue curve).
- u) Graph of wheel total first harmonic (red curve).
- v) Rim (left and right) radial runout peak to peak values.
- w) Graph of rim left radial runout (blue curve).
- x) Graph of rim right radial runout (dashed green curve).
- v1) Rim (left and right) lateral runout peak to peak values.
- w1) Graph of rim left lateral runout (blue curve).
- x1) Graph of rim right lateral runout (dashed green curve).

**10.0 Changing modes of operation**

See geodyna 6800 basic model instructions.



## 11.0 Optional functions



**11.0-1**

The wheel balancer has additional functions, which can be enabled individually after purchasing the machine. They are enabled by plugging a software key (fig. 11.0-1) into one of the USB ports on the back of the machine (fig. 11.0-2).

Each USB key acts exclusively as an enabling device and its presence on the machine is essential in order to use the Optional Functions. The USB key must remain plugged in constantly until the cycle of the Function it enables is complete.

You can plug in the key at any moment. The program recognises the key immediately and the Optional Function is instantly made available, without the operator having to perform any other procedures.

The key can also be removed at any moment, disabling any Optional Functions.

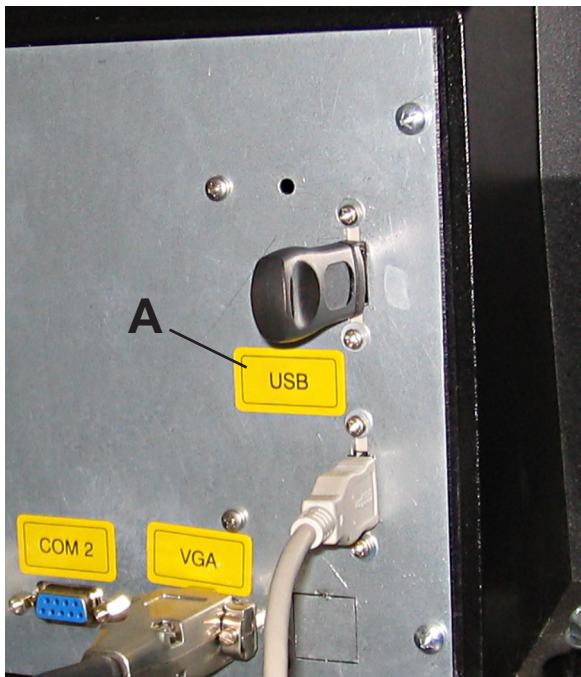

**11.0-2**

THE OPTIONAL FUNCTIONS ARE ONLY ACTIVE WHEN THE USB KEY IS PLUGGED INTO THE MACHINE'S USB PORT.

AS SOON AS THE KEY IS REMOVED FROM THE USB PORT THE OPTIONAL FUNCTIONS ARE NO LONGER AVAILABLE ON THE MACHINE.

### How to use the key:

- Plug the key into one of the USB ports, shown by the yellow sticker (A fig. 11.0-2), on the back of the machine.

Keep the key by leaving it plugged into the machine's USB port.

## 11.1 OPTI LINE mode

The OPTI LINE mode is a computerised function designed to improve the vehicle "PULL" effect, that is to say, the lateral pull force caused by excessive tread conicity, as well as to minimise the vibrations caused by any residual wheel unbalance.

**Note:** **OPTI LINE** is an optional function which must be requested and enabled separately.

With the OPTI LINE mode (function only possible in OPTIMA mode) the balancer analyses a set of wheels, saving their tread conicity index. When the procedure is complete the machine selects the best four wheels, suggesting the order in which they should be mounted to minimise the lateral pull force they produce on the moving vehicle.

The "PULL" effect caused by excessive tread conicity, which cannot be corrected by means of wheel positioning, can be eliminated thanks to Optima's OPTI LINE mode, using the "Set of Wheels" procedure.

Start the "Set of Wheels" procedure and the run, then complete compensation of the unbalance, remove the wheel from the balancer and finally assign the wheel to the Set, saving its data. When the procedure is complete, repeat these operations for up to five wheels. When the fourth wheel is assigned to the Set, a suggestion for mounting on the vehicle is provided, allowing you to conclude the procedure. After entry of the fifth wheel, the program selects and proposes the best four wheels with the relative mounting suggestion.

### Procedure:

- Check that the key which enables the Optional Function is plugged in. See section 11.0.

**Note:** The OptiLine mode is active on the machine when the specific USB key is plugged in. If the key is removed the Function is not available.

- Check that OPTIMA mode is switched on.
- Press **F6** to go to the OPTIMA ENTRY SCREEN.
- Press **F6** to switch on the Set of Wheels procedure.

**Note:** When the "Set of Wheels" procedure is on, the status bar shows the relative icon (Fig. 11.1-1) and key F6 shows the OPTIMA icon again for exiting and returning to OPTIMA mode.

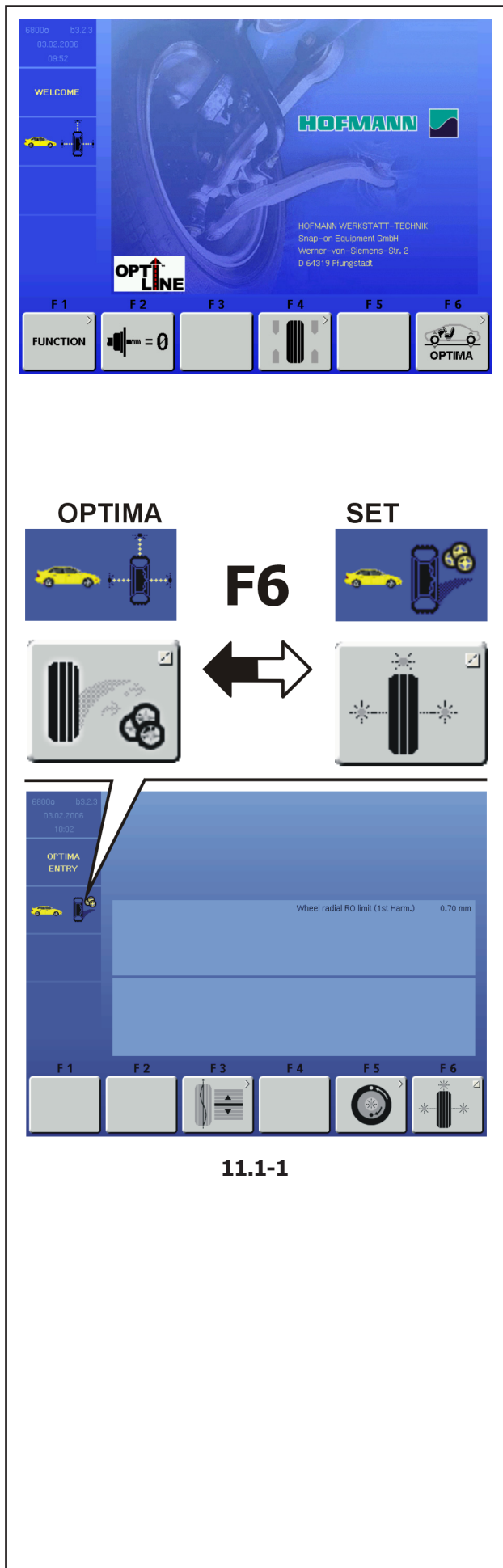

11.1-1

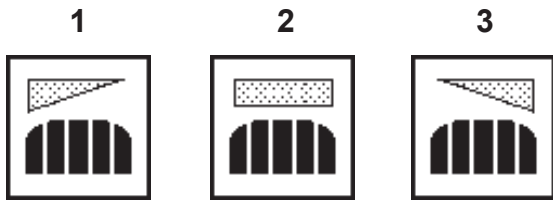

11.1-2

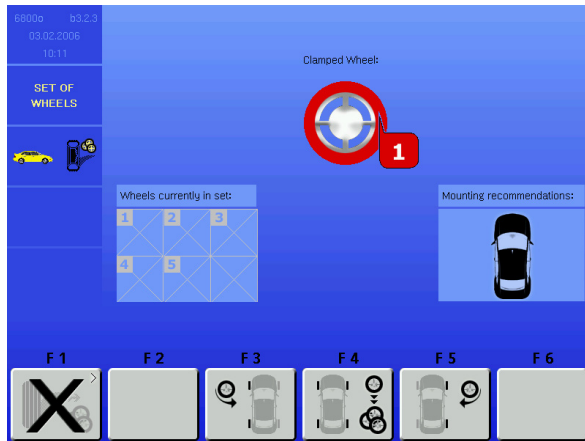

11.1-3

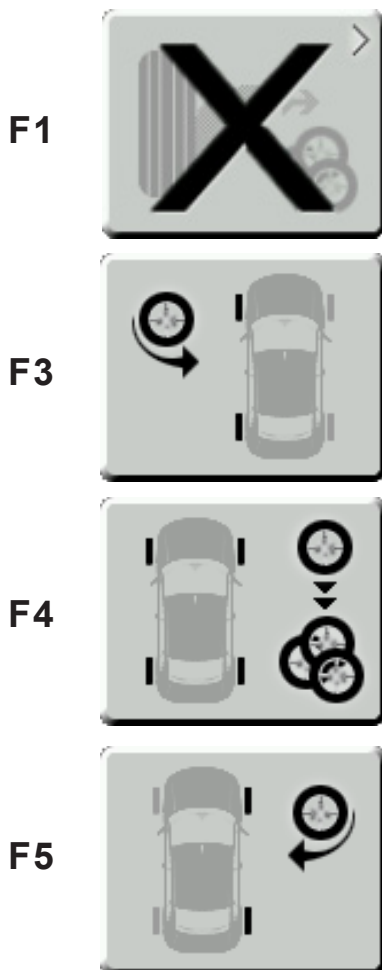

11.1-4

### WHEEL No. 1

- Mount the wheel on the balancer shaft.
- Perform the run.

The balancer completes the optima program readings, then the rear laser scanner scans the tread to acquire the concity indices.

**Note:** The overall cycle time is increased by this operation.

The icon indicating the tread concity angle appears on the OPTIMA ENTRY screen page (Fig. 11.1-2).

The meanings of the icons are as follows:

- 1) Tread concity reading with pull towards LEFT.
- 2) Tread concity reading with NEUTRAL pull.
- 3) Tread concity reading with pull towards RIGHT.

- Balance the planes and make any corrections suggested by *optima*.
- Remove the wheel from the balancer.

When you remove the wheel, the screen shows a number and a colour assigned to the wheel, useful for identifying it until the procedure is complete (Fig. 11.1-3).

From this moment the keys in the control bar have the following functions (Fig. 11.1-4):

#### Key F1

EXIT the Set of Wheels program; the data acquired up to this point is definitively deleted. The machine returns to the OPTIMA ENTRY screen and stands by for further commands.

#### Key F3

ENTER a wheel which can be mounted only on the left of the vehicle; tyres with mandatory direction.

#### Key F4

ENTER a wheel without direction constraints, which can therefore be used on either side of the vehicle.

#### Key F5

ENTER wheels which can only be mounted on the right of the vehicle; tyres with mandatory direction.

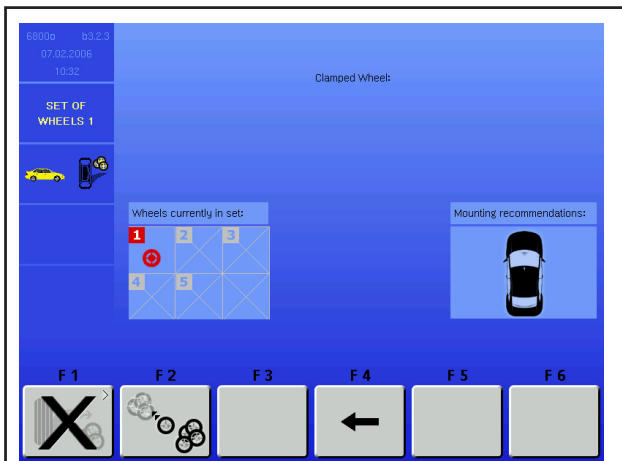

11.1-5

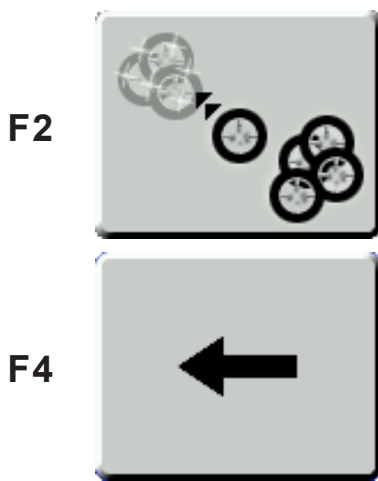

11.1-6

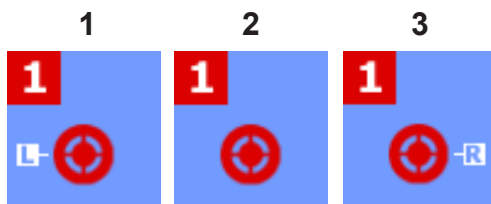

11.1-7

11.1-8

To continue,

- Select one of the keys **F3**, **F4** or **F5** to add the wheel to the Set, assigning the mandatory side mounting position if necessary.

The **"SET OF WHEELS 1"** screen page appears automatically (Fig. 11.1-5).

The screen page shows new keys, for moving backwards in the Set of Wheels procedure (Fig. 11.1-6):

**Key F2**

Deletes the current Set and starts a new "Set of Wheels".

The last wheel examined will be kept and automatically proposed again as wheel number 1 of the new Set.

- Note:** Starting with wheel No. 2, the key will be available for wheel removal, as an alternative to entry keys F3, F4, F5.

**Key F4**

RETURN to the previous step, so that you can assign the wheel a different use in the Set.

The wheels definitively acquired in the memory are represented by icons grouped in the "Wheels Currently in the Set" box. These icons also show any specific mandatory position assigned as described (Fig. 11.1-7):

- 1) Wheel assigned only to left side of vehicle.
- 2) Wheel available for both sides of vehicle.
- 3) Wheel assigned only to right side of vehicle.

To continue,

- Apply the appropriate identification tag to the wheel valve, with the same number and colour as the last wheel shown (Fig. 11.1-8).

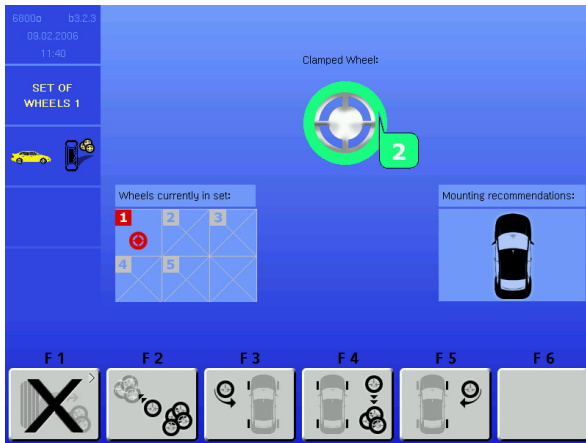

11.1-9

### WHEEL No. 2

- Mount the wheel on the balancer shaft.
- Perform the run.
- Balance the planes and make any corrections suggested by *optima*.
- Remove the wheel from the balancer.

The screen page shows the wheel with the number after the previous one and a different colour (Fig. 11.1-9).

- Select one of the keys **F3**, **F4** or **F5** to enter the current wheel in the set.

The "SET OF WHEELS 2" screen page appears automatically (Fig. 11.1-10).

**Note:** After selecting key **F3** or key **F5** twice in the procedure, the program does not allow you to select this key again.

You cannot assign more than two wheels to the same side of the vehicle.

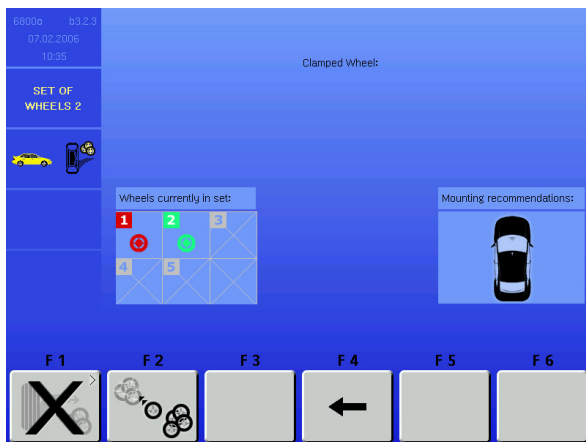

11.1-10

### WHEEL No. 3

- Perform the procedure as described for wheel No. 2.

### WHEEL No. 4

- Perform the procedure as described for wheel No. 2.

At this point of the procedure the machine already has a first mounting suggestion.

The box on the right shows the number and colour of each wheel in the appropriate mounting position on the vehicle (Fig. 11.1-11) for optimising the PULL.

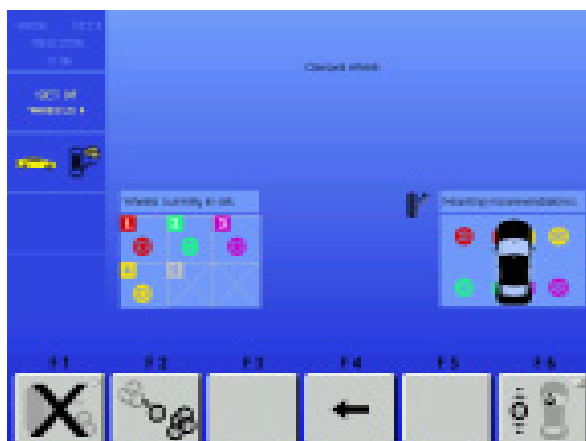

11.1-11

You can now select one of these options:

"Optimise vibrations",

"Enter fifth wheel"

"Start a new Set of Wheels", or

"Terminate and exit procedure"

as described below.

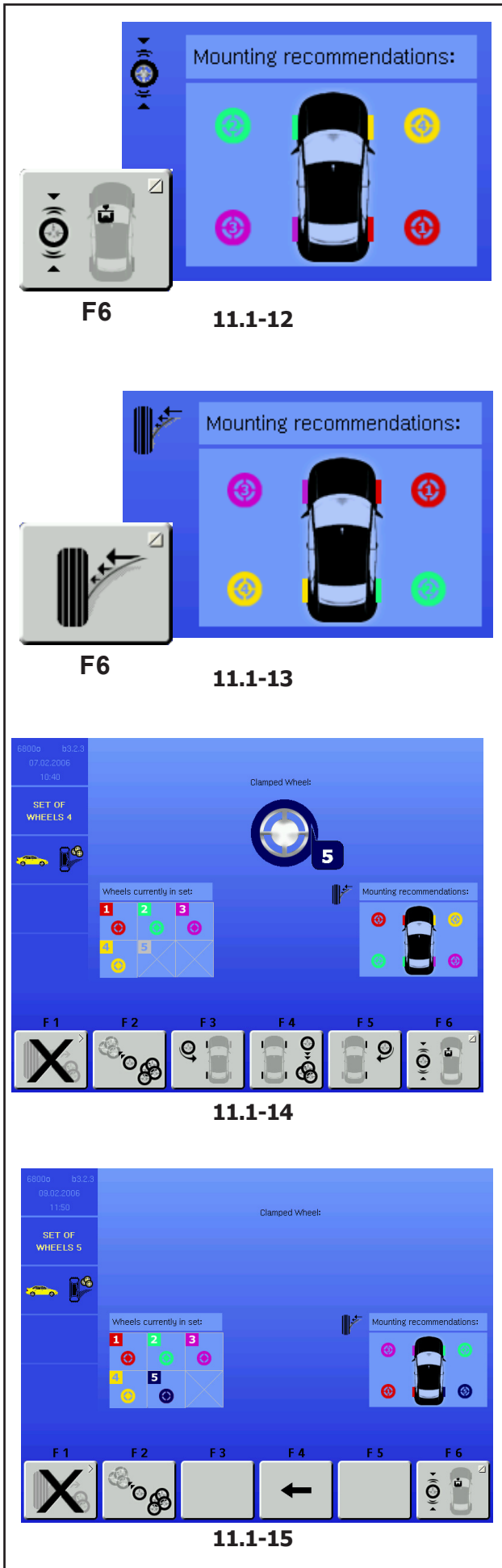

**Optimise vibrations**

As an alternative to the mounting recommendation for the set of wheels to minimise the PULL, you can select a different set-up, suggested to reduce the vibrations caused by any residual unbalance on the wheels in the Set.

- Press key **F6** to view the recommended mounting option for optimising vibrations (Fig. 11.1-12).

If you follow this mounting diagram the driver's side of the vehicle will benefit by feeling the least possible vibrations.

**Note:** The different mounting suggestions which can be selected are not correlated. You must choose one of the recommended mounting options, depending on the priority correction requirement for the vehicle in question.

- Press key **F6** again to view the mounting recommendation for PULL optimisation seen before (Fig. 11.1-13).

**Note:** Key **F6** allows you to toggle between the different mounting options. The icon on the top left of the screen indicates the type of optimisation referred to by the mounting order shown at that time.

**Enter fifth wheel**

(Fig. 11.1-14)  
The Set of Wheels procedure in the OPTI LINE mode allows the entry of a fifth wheel in the set, to guarantee greater scope for improvement.

**WHEEL No. 5**

- Perform the procedure as described for wheel No. 2.

When you enter the 5th wheel in the Set the **"SET OF WHEELS 5"** screen page appears automatically (Fig. 11.1-15) and the selection of the best four wheels is shown, with their relative positions on the vehicle, taken from the set of five wheels processed.

**Note:** No further wheels can be entered in the Set. If you try to enter another wheel the machine starts the procedure for a new Set of Wheels and all of the data relative to the previous Set will be deleted.

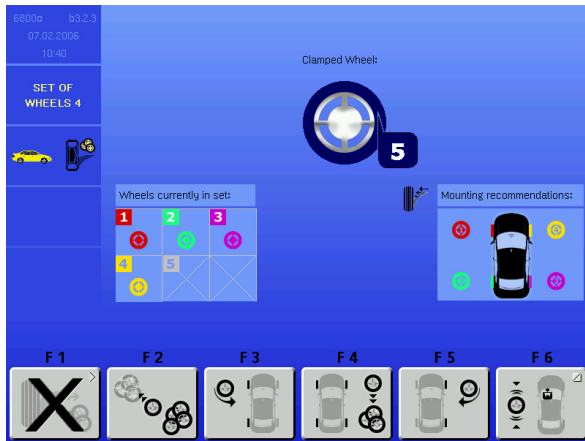

11.1-14

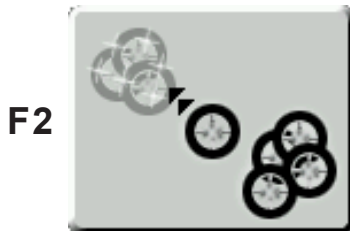

11.1-6



11.1-4

### Start a new Set of Wheels

After entry of WHEEL No. 5 in a Set, you can start a new Set, without exiting the Set of Wheels mode. Proceed as follows:

- Perform the procedure as described for wheel No. 1.

The machine deletes the data relative to the previous wheels and shows the current wheel as the first wheel in a new Set.

After entry of WHEEL No. 4 in a Set you can start a new Set, without exiting the Set of Wheels mode. Proceed as follows:

- Mount the wheel on the balancer shaft.
- Perform the run.
- Complete any normal correction and balancing operations required.
- Remove the wheel from the balancer.

Wheel number 5 is shown on the screen page (Fig. 11.1-14).

- Press key F2 (Fig. 11.1-6).

The machine deletes the data relative to the previous wheels and shows the last wheel as wheel number 1, starting a new Set of Wheels.

### Terminate and exit procedure

To exit the Set of Wheels procedure and return to the OPTIMA ENTRY screen page.

- Press key F1 (Fig. 11.1-4).

All data relative to the Set of Wheels is deleted.

## 11.1.1 PULL calibration

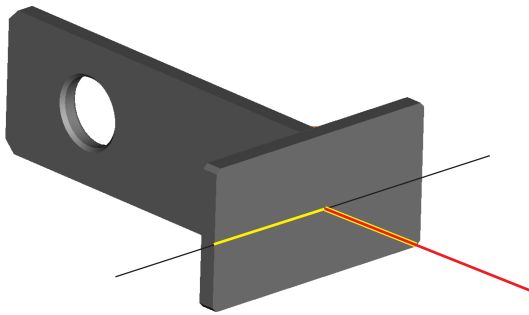

**11.1.1-1**

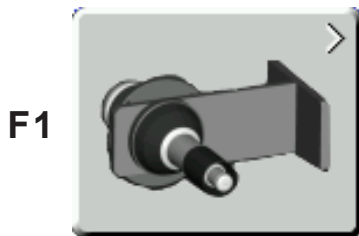

**11.1.1-2**

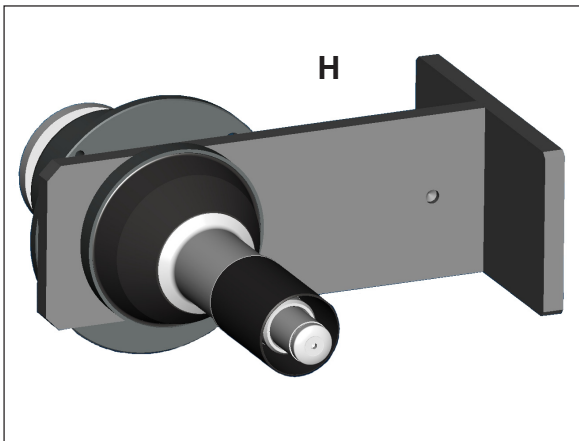

**11.1.1-3**

The PULL calibration procedure is available if the OPTI LINE mode is installed.

This procedure is for checking and correcting any parallax problems between the rear scanner running plane and the axis of the machine wheel shaft, to guarantee precision measurement of the tread conicity indices.

The procedure uses the special Calibration Tool supplied, on whose front surface the rear laser's beam must run (Fig. 11.1.1-1).

**CAUTION:** HANDLE THE CALIBRATION TOOL WITH CARE. AVOID BUMPS AND KEEP IN A SAFE PLACE.

Calibration must be carried out regularly.

When using the Set of Wheels procedure, the last calibration should have been performed within a month.

To perform the PULL calibration, proceed as follows:

- Open the OPTIMA screen page (**F6**).
- Select key **F3** to open the OPTIMA PARAMETERS screen page.
- Select key **F1** (Fig. 11.1.1-2).
- Install the Calibration Tool so that the blind hole used as a reference faces the outside of the machine, as illustrated (**H**, Fig. 11.1.1-3).
- Turn the front surface of the Tool towards the back of the balancer, angle the plate towards the scanner, then lock it in position using the pedal brake.
- Lower the wheel guard.
- Press **F6** to start calibration.

The rear scanner starts up, starting the calibration.

If the difference between the PULL index calculated by the user calibration and the value set by the factory calibration is less than 0.5, the operation ends with a positive result and the text OK appears.

If not, error E400 is signalled (see "Error Messages" section).

- Remove the calibration tool.

**Note:** For an on-line description of the procedure select the HELP key in the OPTIMA PARAMETERS screen page.



## 12.0 Error codes

**Note:** E Prefix = Errors in operation  
H Prefix = Warnings

The error codes are displayed for ca. 3 seconds on the left of the screen above the F1 menu key with an E followed by the numerical code (e.g. E10). Use the HELP key to call up a help text (installed as of version 1.34 of the software).

- To cancel the error message, the error must be removed (e.g. open the wheel guard) or press the STOP or ESC key.

The error messages with reference to the optima wheel balancer functionality are described below:

### **E1**

**Rim dimensions incorrect or incomplete.**

- Repeat rim data input.
- If the problem persists, you can have a manual data entry by pressing F1 in the balancing screen.

### **E30**

**No runout detection.**

- Repeat the measuring run to determine the runout detection.
- If the problem persists call service.

### **E31**

**If the operator, following a rim profile reading, chooses to proceed with a complete wheel measurement, the control software prevents the operation because only the presence of the rim is detected.**

- Fit a tire on the rim.

### **E32**

**The user selected to proceed with a bare rim measurement but the machine actually detects that a complete wheel is on the machine.**

- Mount a bare rim.

**E40****Printing error. Check that:**

- the printer is connected to the balancer;
- the printer is switched on;
- there is paper.
- If the problem persists, reset the printer by disconnecting and connecting the power supply cable.

**E360****Wheel profiler position calibration required**

Possible causes:

- the camera controller board has been replaced
- at least one scanner has been replaced
- the calibration data is missing
- the scanner cables have been swapped

Corrective actions:

- check the connections
- calibration procedure (C122) is required to calibrate the actual position of the laser scanners with respect to the balancer reference plane.

**E361****Wheel profiler not present or not responding during self test**

The balancer controller board was not able to communicate with the camera controller board during power on self test.

Possible causes:

- the camera controller board is missing or damaged
- the flat cable connecting the keyboard, the balancer controller board and the camera controller board is unplugged, damaged or missing

Corrective actions:

- check the camera controller board
- check the connections
- re-install the camera controller board software.

### **E362**

#### **Main camera board power on self test failure**

Possible causes:

- there is a fault in the camera controller board
- the flat cable connecting the keyboard, the balancer controller board and the camera controller board is partially unplugged or damaged
- the supply voltage is not configured properly on the power interface board

Corrective actions:

- check the camera controller board
- check the connections
- check the supply voltage with service code C110.

### **E363**

Left scanner self test failed, CCD not reset or zero point mark not detected.

The balancing is not possible as the laser scanners cannot detect the wheel data.

Problems have occurred at power-on.

- Switch off and power-on again.
- If the problem persists call service.

### **E364**

Right scanner self test failed, CCD not reset or zero point mark not detected.

The balancing is not possible as the laser scanners cannot detect the wheel data.

Problems have occurred at power-on.

- Switch off and power-on again.
- If the problem persists call service.

**E365****Rear scanner self test failed, CCD not reset or zero point mark not detected.**

The laser scanners can detect the wheel data: the balancing is possible, but the runout measurement cannot be carried out.

Problems have occurred at power-on.

- Switch off and power-on again.
- If the problem persists call service.

**E366****Main camera board memory self test failure**

Possible causes:

- there is a fault in the camera controller board

Corrective actions:

- check the camera controller board.

**E367****Motor power supply missing or out of range**

Possible causes:

- the cable connecting the camera controller board and the motor power supply is unplugged, damaged or missing
- the motor power supply is not configured properly
- there is a fault in the motor power supply board
- the cable connecting the mains supply and the motor power supply board is unplugged, damaged or missing

Corrective actions:

- check all items above.

**E368****Main camera board A/D converter failure**

Possible causes:

- there is a fault in the camera controller board

Corrective actions:

- check the camera controller board.

**E369****Main shaft encoder zero mark detection failure or missing cable**

Possible causes:

- there is a fault in the camera controller board
- there is a fault in the encoder

- the cable connecting the camera controller board and the encoder board is unplugged, missing or damaged

Corrective actions:

- check the camera controller board
- check the encoder
- check the connections.

### **E370**

#### **Inner CCD signals failure**

Possible causes:

- the flat cable connecting the camera controller board and the inner scanner CCD board is unplugged, missing or damaged
- there is a fault in the inner scanner CCD board
- there is a fault in the camera controller board
- the supply voltage is configured too high on the power interface board

Corrective actions:

- check all items above
- switch power off and on again; should the problem not go away please call service.

### **E371**

#### **Inner scanner memory not responding**

Possible causes:

- the flat cable connecting the camera controller board and the inner scanner CCD board is unplugged, missing or damaged
- there is a fault in the inner scanner CCD board
- there is a fault in the camera controller board

Corrective actions:

- check the connections
- check the inner scanner CCD board
- check the camera controller board
- switch power off and on again; should the problem not go away please call service.

### **E372**

#### **Inner scanner memory not valid**

Possible causes:

- the flat cable connecting the camera controller board and the inner scanner CCD board is partially unplugged or damaged
- there is a fault in the inner scanner CCD board

Corrective actions:

- check the connections

- check the inner scanner CCD board
- switch power off and on again; should the problem not go away please call service.

**E373****Inner scanner not calibrated**

Possible causes:

- the inner scanner has not been factory calibrated

Corrective actions:

- please call service and replace the inner scanner.

**E374****Inner motor current sink or power supply failure**

Possible causes:

- the cable connecting the camera controller board and the inner scanner motor is unplugged, damaged or missing
- the motor power supply is not configured properly
- there is a fault in the motor power supply board
- the cable connecting the mains supply and the motor power supply board is unplugged, damaged or missing
- there is a fault in the inner scanner motor
- there is a fault in the camera controller board motor drivers

Corrective actions:

- check all items above.

**E375****Inner scanner zero mark not detected**

Possible causes:

- the flat cable connecting the camera controller board and the inner scanner CCD board is unplugged, missing or damaged
- there is a fault in the inner scanner CCD board
- the inner scanner is locked
- the inner scanner zero mark is missing, bent, locked or damaged
- the cable connecting the camera controller board and the inner scanner motor is unplugged, damaged or missing
- there is a fault in the motor power supply board
- there is a fault in the inner scanner motor
- there is a fault in the camera controller board motor drivers

Corrective actions:

- check all items above.

### **E376**

#### **Inner motor missing steps**

Possible causes:

- the inner scanner movement is not smooth or it is striking the frame
- the motor power supply is not configured properly
- there is a fault in the motor power supply board
- there is a fault in the inner scanner motor
- there is a fault in the camera controller board motor drivers
- the cable connecting the camera controller board and the inner scanner motor is partially unplugged or damaged

Corrective actions:

- check all items above.

### **E377**

#### **Inner laser current sink or power supply failure**

Possible causes:

- the flat cable connecting the camera controller board and the inner scanner CCD board is unplugged, missing or damaged
- the cable of the laser module of the inner scanner is damaged or there is a fault in the laser module itself
- there is a fault in the camera controller board laser drivers

Corrective actions:

- check all items above.

### **E378**

#### **Inner laser modulation failure**

Possible causes:

- the flat cable connecting the camera controller board and the inner scanner CCD board is unplugged, missing or damaged
- the cable of the laser module of the inner scanner is damaged or there is a fault in the laser module itself
- there is a fault in the camera controller board laser drivers

Corrective actions:

- check all items above.

**E380**  
**Outer CCD signals failure**

Possible causes:

- the flat cable connecting the camera controller board and the outer scanner CCD board is unplugged, missing or damaged
- there is a fault in the outer scanner CCD board
- there is a fault in the camera controller board
- the supply voltage is configured too high on the power interface board

Corrective actions:

- check all items above
- switch power off and on again; should the problem not go away please call service.

**E381**  
**Outer scanner memory not responding**

Possible causes:

- the flat cable connecting the camera controller board and the outer scanner CCD board is unplugged, missing or damaged
- there is a fault in the outer scanner CCD board
- there is a fault in the camera controller board

Corrective actions:

- check the connections
- check the outer scanner CCD board
- check the camera controller board
- switch power off and on again; should the problem not go away please call service.

**E382**  
**Outer scanner memory not valid**

Possible causes:

- the flat cable connecting the camera controller board and the outer scanner CCD board is partially unplugged or damaged
- there is a fault in the outer scanner CCD board

Corrective actions:

- check the connections
- check the outer scanner CCD board
- switch power off and on again; should the problem not go away please call service.



**E383****Outer scanner not calibrated**

Possible causes:

- the outer scanner has not been factory calibrated

Corrective actions:

- please call service and replace the outer scanner.

**E384****Outer motor current sink or power supply failure**

Possible causes:

- the cable connecting the camera controller board and the outer scanner motor is unplugged, damaged or missing
- the motor power supply is not configured properly
- there is a fault in the motor power supply board
- the cable connecting the mains supply and the motor power supply board is unplugged, damaged or missing
- there is a fault in the outer scanner motor
- there is a fault in the camera controller board motor drivers

Corrective actions:

- check all items above.

**E385****Outer scanner zero mark not detected**

Possible causes:

- the flat cable connecting the camera controller board and the outer scanner CCD board is unplugged, missing or damaged
- there is a fault in the outer scanner CCD board
- the outer scanner is locked
- the outer scanner zero mark is missing, bent, locked or damaged
- the cable connecting the camera controller board and the outer scanner motor is unplugged, damaged or missing
- there is a fault in the motor power supply board
- there is a fault in the outer scanner motor
- there is a fault in the camera controller board motor drivers

Corrective actions:

- check all items above.

**E386****Outer motor missing steps**

Possible causes:

- the outer scanner movement is not smooth or it is striking the frame
- the motor power supply is not configured properly
- there is a fault in the motor power supply board
- there is a fault in the outer scanner motor
- there is a fault in the camera controller board motor drivers
- the cable connecting the camera controller board and the outer scanner motor is partially unplugged or damaged

Corrective actions:

- check all items above.

**E387****Outer laser current sink or power supply failure**

Possible causes:

- the flat cable connecting the camera controller board and the outer scanner CCD board is unplugged, missing or damaged
- the cable of the laser module of the outer scanner is damaged or there is a fault in the laser module itself
- there is a fault in the camera controller board laser drivers

Corrective actions:

- check all items above.

**E388****Outer laser modulation failure**

Possible causes:

- the flat cable connecting the camera controller board and the outer scanner CCD board is unplugged, missing or damaged
- the cable of the laser module of the outer scanner is damaged or there is a fault in the laser module itself
- there is a fault in the camera controller board laser drivers

Corrective actions:

- check all items above.

### **E390**

#### **Rear CCD signals failure**

Possible causes:

- the flat cable connecting the camera controller board and the rear scanner CCD board is unplugged, missing or damaged
- there is a fault in the rear scanner CCD board
- there is a fault in the camera controller board
- the supply voltage is configured too high on the power interface board

Corrective actions:

- check all items above
- switch power off and on again; should the problem not go away please call service.

### **E391**

#### **Rear scanner memory not responding**

Possible causes:

- the flat cable connecting the camera controller board and the rear scanner CCD board is unplugged, missing or damaged
- there is a fault in the rear scanner CCD board
- there is a fault in the camera controller board

Corrective actions:

- check the connections
- check the rear scanner CCD board
- check the camera controller board
- switch power off and on again; should the problem not go away please call service.

### **E392**

#### **Rear scanner memory not valid**

Possible causes:

- the flat cable connecting the camera controller board and the rear scanner CCD board is partially unplugged or damaged
- there is a fault in the rear scanner CCD board

Corrective actions:

- check the connections
- check the rear scanner CCD board
- switch power off and on again;
- should the problem not go away please call service.

**E393****Rear scanner not calibrated**

Possible causes:

- the rear scanner has not been factory calibrated

Corrective actions:

- please call service and replace the rear scanner.

**E394****Rear motor current sink or power supply failure**

Possible causes:

- the cable connecting the camera controller board and the rear scanner motor is unplugged, damaged or missing
- the motor power supply is not configured properly
- there is a fault in the motor power supply board
- the cable connecting the mains supply and the motor power supply board is unplugged, damaged or missing
- there is a fault in the rear scanner motor
- there is a fault in the camera controller board motor drivers

Corrective actions:

- check all items above.

**E395****Rear scanner zero mark not detected**

Possible causes:

- the flat cable connecting the camera controller board and the rear scanner CCD board is unplugged, missing or damaged
- there is a fault in the rear scanner CCD board
- the rear scanner is locked
- the rear scanner zero mark is missing, bent, locked or damaged
- the cable connecting the camera controller board and the rear scanner motor is unplugged, damaged or missing
- there is a fault in the motor power supply board
- there is a fault in the rear scanner motor
- there is a fault in the camera controller board motor drivers

Corrective actions:

- check all items above.

### **E396**

#### **Rear motor missing steps**

Possible causes:

- the rear scanner movement is not smooth or it is striking the frame
- the motor power supply is not configured properly
- there is a fault in the motor power supply board
- there is a fault in the rear scanner motor
- there is a fault in the camera controller board motor drivers
- the cable connecting the camera controller board and the rear scanner motor is partially unplugged or damaged

Corrective actions:

- check all items above.

### **E397**

#### **Rear laser current sink or power supply failure**

Possible causes:

- the flat cable connecting the camera controller board and the rear scanner CCD board is unplugged, missing or damaged
- the cable of the laser module of the rear scanner is damaged or there is a fault in the laser module itself
- there is a fault in the camera controller board laser drivers

Corrective actions:

- check all items above.

### **E398**

#### **Rear laser modulation failure**

Possible causes:

- the flat cable connecting the camera controller board and the rear scanner CCD board is unplugged, missing or damaged
- the cable of the laser module of the rear scanner is damaged or there is a fault in the laser module itself
- there is a fault in the camera controller board laser drivers

Corrective actions:

- check all items above.

**E400**  
**Pull index user calibration failure**

The pull index user calibration performs a scanning of the flat surface of the calibration flange and calculates a pull index.

This is compared with the factory/service calibration (step 7 of C122):

- if the difference is less then 0.5 degrees, **OK** is displayed and the user calibrated pull index overrides the factory/service value for set of wheels calculations;
- if the difference is more then 0.5 degrees, the error code **E400** is displayed and a service call is suggested; the machine still runs using the most recent factory/service calibrated pull index. This might result in a slight inaccuracy of the conicity measurement.

Corrective actions:

- press **F6** to repeat the procedure  
 press **ESC** or **STOP** to release the brake and exit the procedure.

**E404**  
**Rear shift motor current sink or power supply failure**

Possible causes:

- the cable connecting the camera controller board and the rear shift scanner motor is unplugged, damaged or missing
- the motor power supply is not configured properly
- there is a fault in the motor power supply board
- the cable connecting the mains supply and the motor power supply board is unplugged, damaged or missing
- there is a fault in the rear shift scanner motor
- there is a fault in the camera controller board motor drivers.

Corrective actions:

- check all items above.

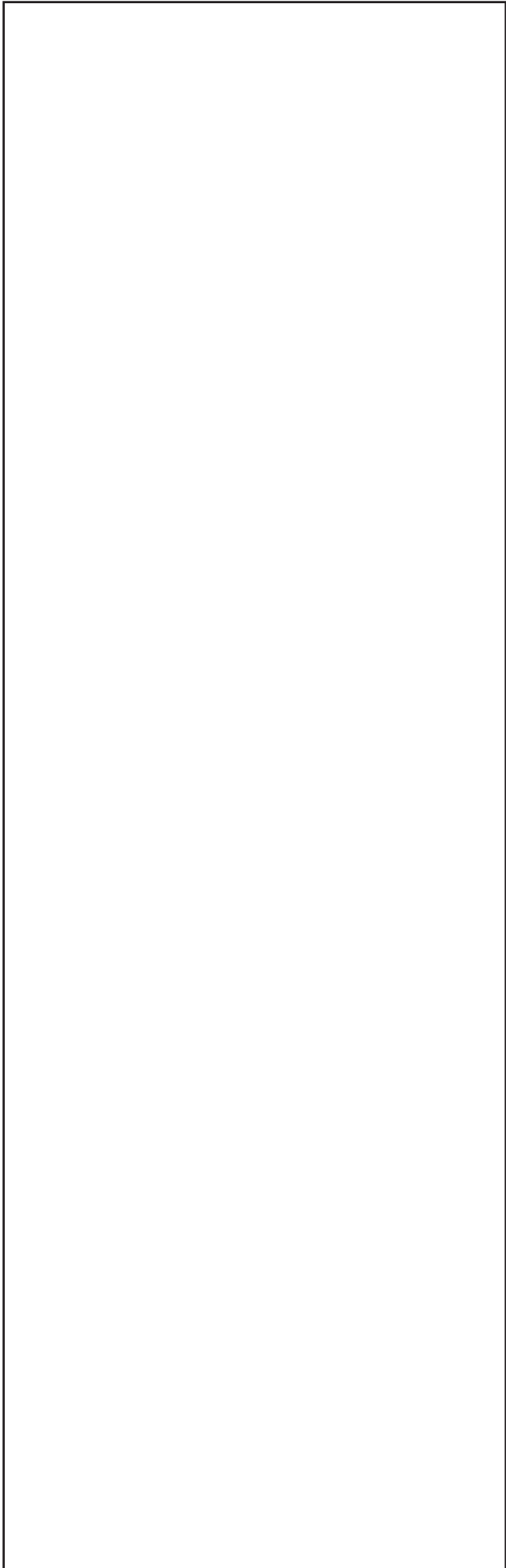

## **E405**

### **Rear shift scanner zero mark not detected**

Possible causes:

- the flat cable connecting the camera controller board and the rear shift scanner CCD board is unplugged, missing or damaged
- there is a fault in the rear shift scanner CCD board
- the rear shift scanner is locked
- the rear shift scanner zero mark is missing, bent, locked or damaged
- the cable connecting the camera controller board and the rear shift scanner motor is unplugged, damaged or missing
- there is a fault in the motor power supply board
- there is a fault in the rear shift scanner motor
- there is a fault in the camera controller board motor drivers

Corrective actions:

- check all items above.

## **E406**

### **Rear shift motor missing steps**

Possible causes:

- the rear shift scanner movement is not smooth or it is striking the frame
- the motor power supply is not configured properly
- there is a fault in the motor power supply board
- there is a fault in the rear shift scanner motor
- there is a fault in the camera controller board motor drivers
- the cable connecting the camera controller board and the rear shift scanner motor is partially unplugged or damaged

Corrective actions:

- check all items above.

**E623****Error in virtual dimensions calculation**

The distance of the left virtual compensation plane from the reference plane in the measuring system is incorrect. One of the unbalance sensors may have been mounted with inverted polarity.

- Check and correct if connection is wrong.



## **13.0 Optimisation / Weight minimisation**

See geodyna 6800 basic model instructions (function can only be carried out in Manual mode).

## **14.0 Readjustment by the operator**

See geodyna 6800 basic model instructions.

## 15.0 Maintenance

---

**WARNING:** PRIOR TO MAINTENANCE OR REPAIR WORK DISCONNECT THE MACHINE FROM THE MAINS SUPPLY AND PROTECT AGAINST UNINTENTIONAL SWITCHING ON.

---

**Note:** refer to the geodyna 6800 basic model instructions for all the maintenance and cleaning operations.

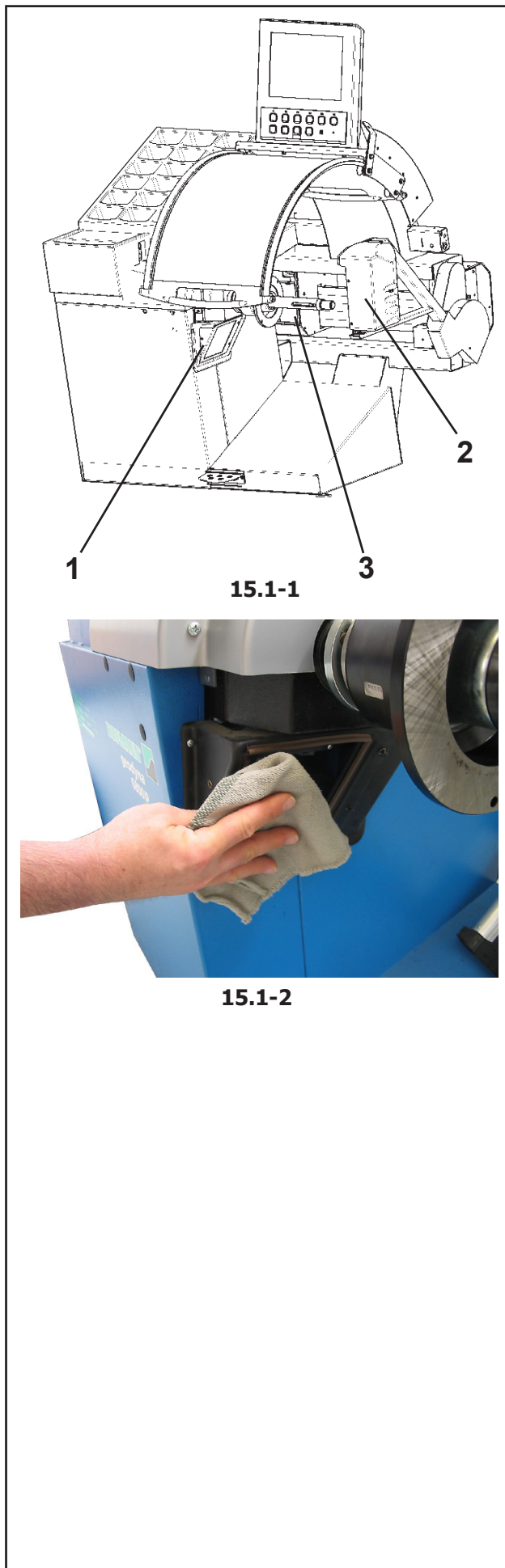

### 15.1 Laser scanners seating glass cleaning

The laser scanners seats (fig. 16.1-1, details 1, 2 and 3) are fitted with a protection glass, which must be regularly dusted. Only use a clean, dry and soft cloth as shown in figure 16.1-2, so as not to make scratches to the glass surface. In case of oil or grease stains, add an ordinary detergent product for glass.

## 16.0 Technical data

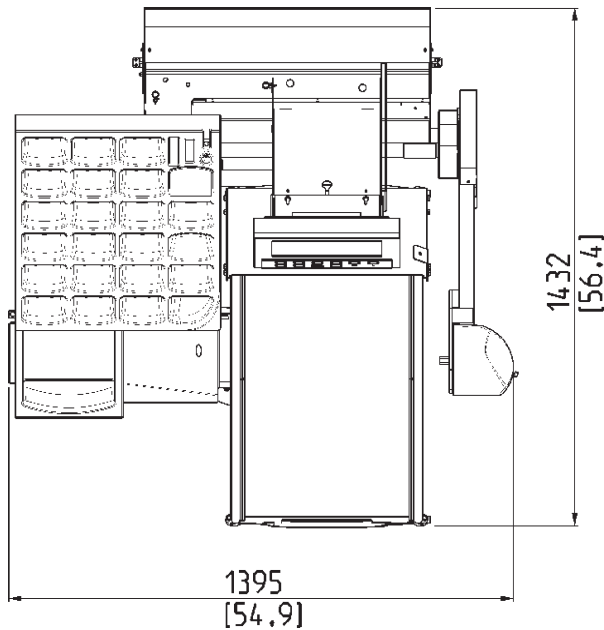

Power supply (v):  
230 volt 1 Ph 50-60 hertz

Series of concentric cones:  
3 cones 43 - 115 mm

Shaft length:  
7.5 " 190 mm

Shaft diameter:  
1.57 " 40 mm

Measuring speed:  
200 rpm

Balancing precision:  
0.035 ounces 1 gr

Scanning device precision:  
0,039" 0.1 mm

Rim width (dynamic balancing):  
3 " - 20"

Rim diameter:  
8 " - 30"

Overall wheel width:  
21" 530 mm

Overall wheel diameter:  
37" 950 mm

Maximum wheel weight:  
154 lbs 70 kg

Maximum cycle time:  
30 sec.

Type of data input for the DISTANCE:  
*Automatic, no contact with the wheel*

Type of data input for the DIAMETER:  
*Automatic, no contact with the wheel*

Type of data input for the WIDTH:  
*Automatic, no contact with the wheel*

Dimensions of the package (mm) H x L x D:  
1640 x 1420 x 1850

Dimensions (mm) H x L x D with wheel guard raised:  
1700 x 1395 x 1150

Shipment weight:  
350 kg

## 17.0 Accessories

### 17.1 Printer

The ink jet colour printer produces a professional report that can be delivered to the client as the balancing certificate. This certificate can function as an extended guarantee of performance.

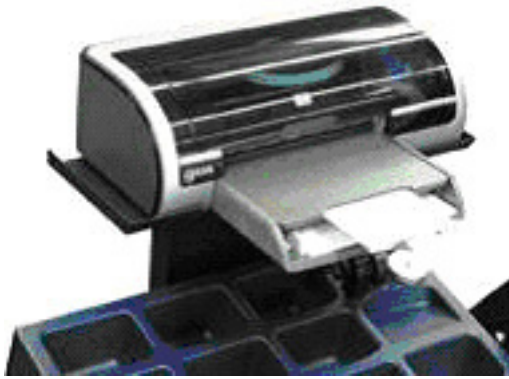

17-1

### 17.2 Wheel elevator

It can operate with a balancer, a tire changer or placed between a balancer and a tire changer. Lifting capacity up to 90 kg.



17-2



17-3

### 17.3 Trolley for Flanges

Designed for the complete range of universal and special perforated flanges (17.4). This accessory guarantees maximum safety in stocking.

### 17.4 Perforated flanges for screw stud

A complete range of 6 universal flanges for all European vehicles. Four flanges designed for North American vehicles. Including bolts. Special flanges for BMW and OPEL available. Special flange for custom-built vehicles.



17-4

### 17.5 SCA Flange

Adaptor for wheels with closed center hole also known as UniLug adaptor.

**When the SCA adaptor is attached to the geodyna optima the power clamp system needs to be switched off in the FUNCTION screen.**

The operation of the geodyna optima depends a lot on the power clamp in order to have the information addressed to the software during some procedures. In order not to loose the capability to know if a wheel has been clamped or not and to keep the procedures identical a special procedure has been implemented when the SCA adaptor is attached to the machine.

**The operator tells the machine that he clamps or unclamp the wheel on SCA adaptor by simply lifting the pedal in the same way as in the standard procedure with the mid centering device.**

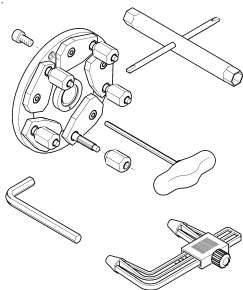

17-5



17-6



17-7

## 17.6 Tapered ring

A centring cone with a 5° taper, to achieve a higher degree of wheel centring precision when fitting the wheel on the balancer.

## 17.7 Wheel weight removal tool

Special tool in wear resistant plastic material, essential for the removal of adhesive weights from alloy wheels. Ensures that the rim surfaces are not damaged.

## 18.0 Mise en place de la Imprimante (disponible en option) Printer Installation Instructions (optional)

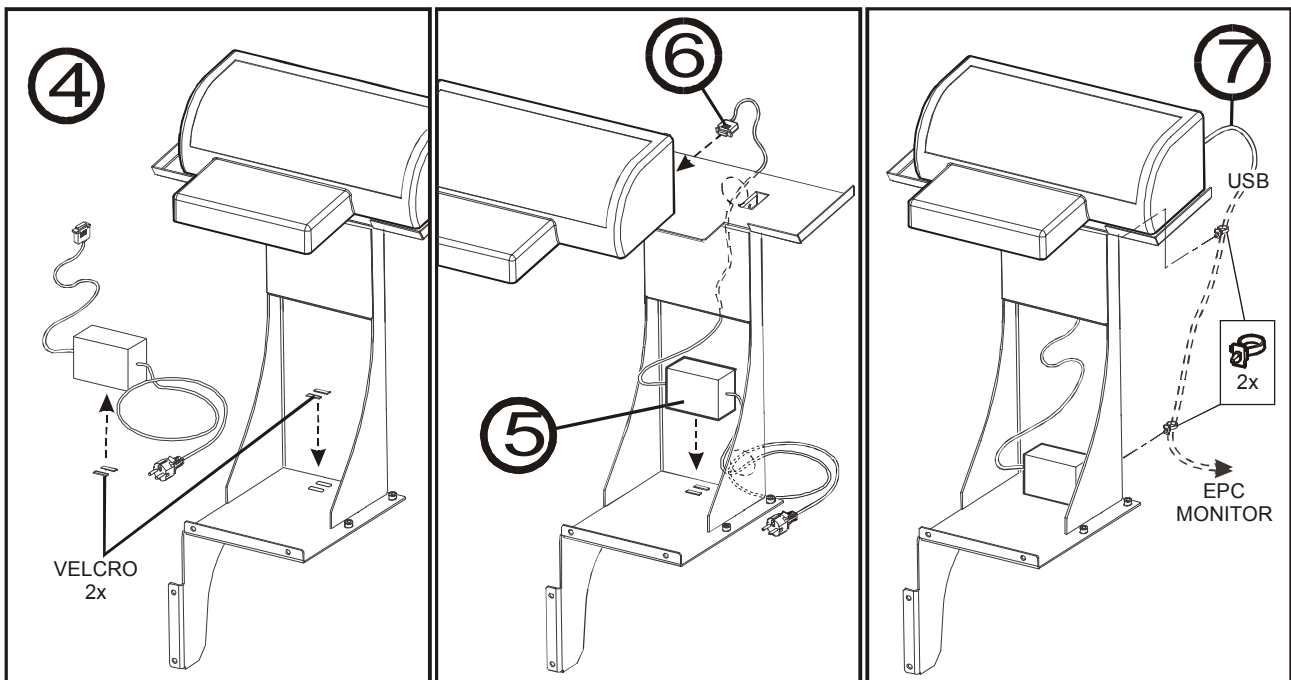
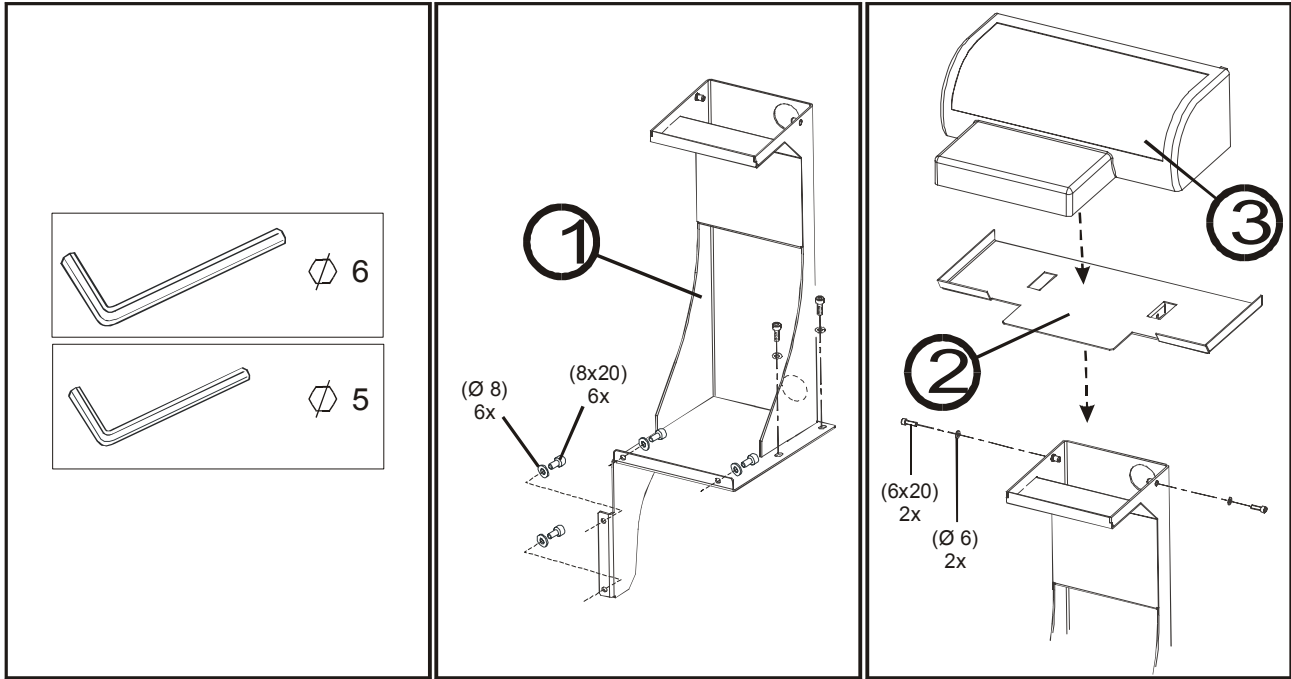



Electrical diagram

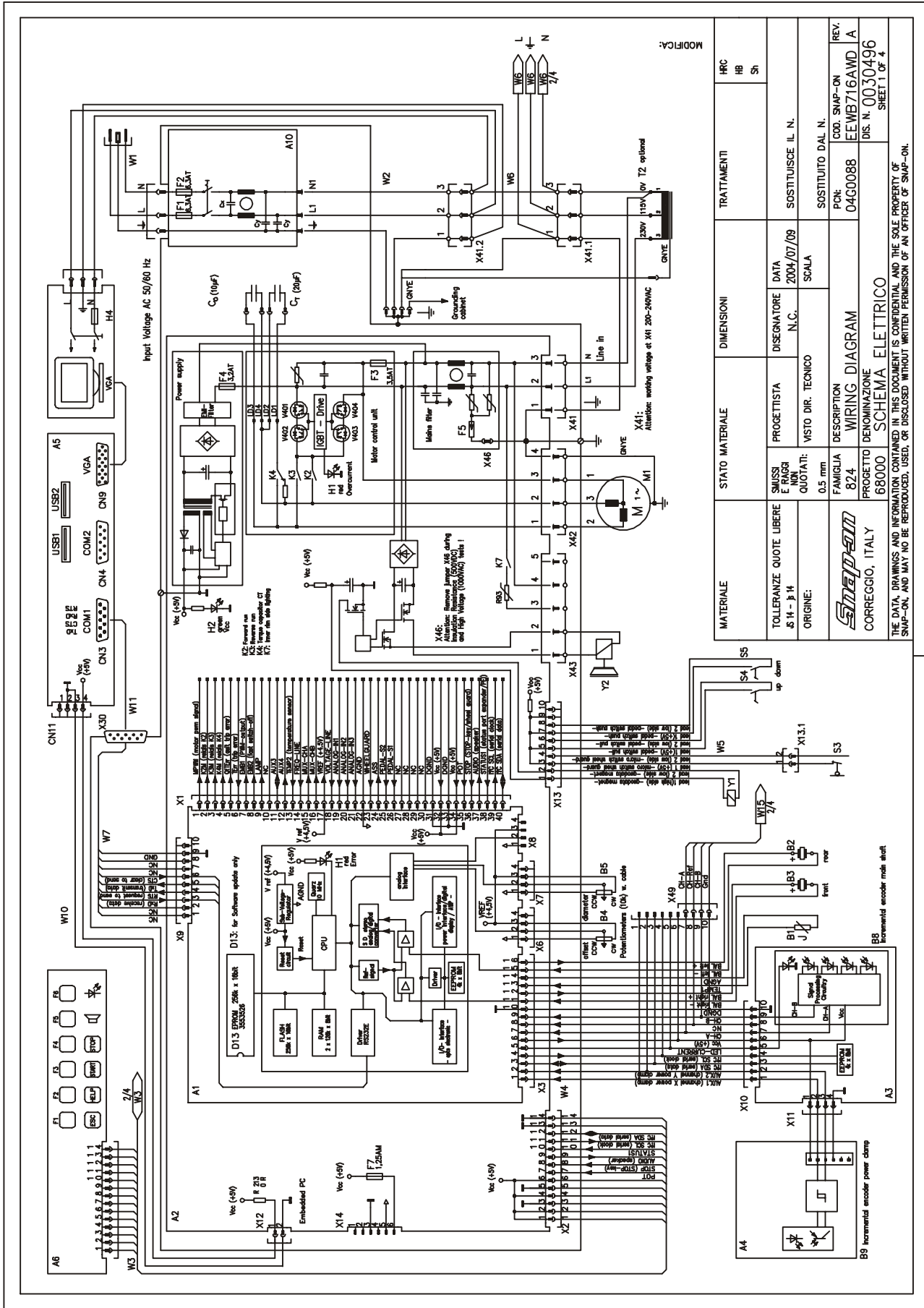

MATERIALE	STATO MATERIALE	DIMENSIONI	TRATTAMENTI	HRC
TOLLERANZE QUOTE LIBERE S 14 - B 14	SMUSSE E RAGGI NON QUOTATI: 0.5 mm	PROGETTISTA N.C.	DISCOSTITUISCE IL N.	HB SH
ORIGINE: <b>SNAP-ON</b> CORREGGIO, ITALY	FAMIGLIA 824	DESCRIZIONE WIRING DIAGRAM	SOSTITUITO DAL N.	
		DENOMINAZIONE SCHEMA ELETTRICO	PCN: 04G0088	REV. A
			DIS. N. 0030496	SHEET 1 OF 4

THE DATA, DRAWINGS AND INFORMATION CONTAINED IN THIS DOCUMENT IS CONFIDENTIAL AND THE SOLE PROPERTY OF SNAP-ON. AND MAY NOT BE REPRODUCED, USED, OR DISCLOSED WITHOUT WRITTEN PERMISSION OF AN OFFICER OF SNAP-ON.



Electrical diagram

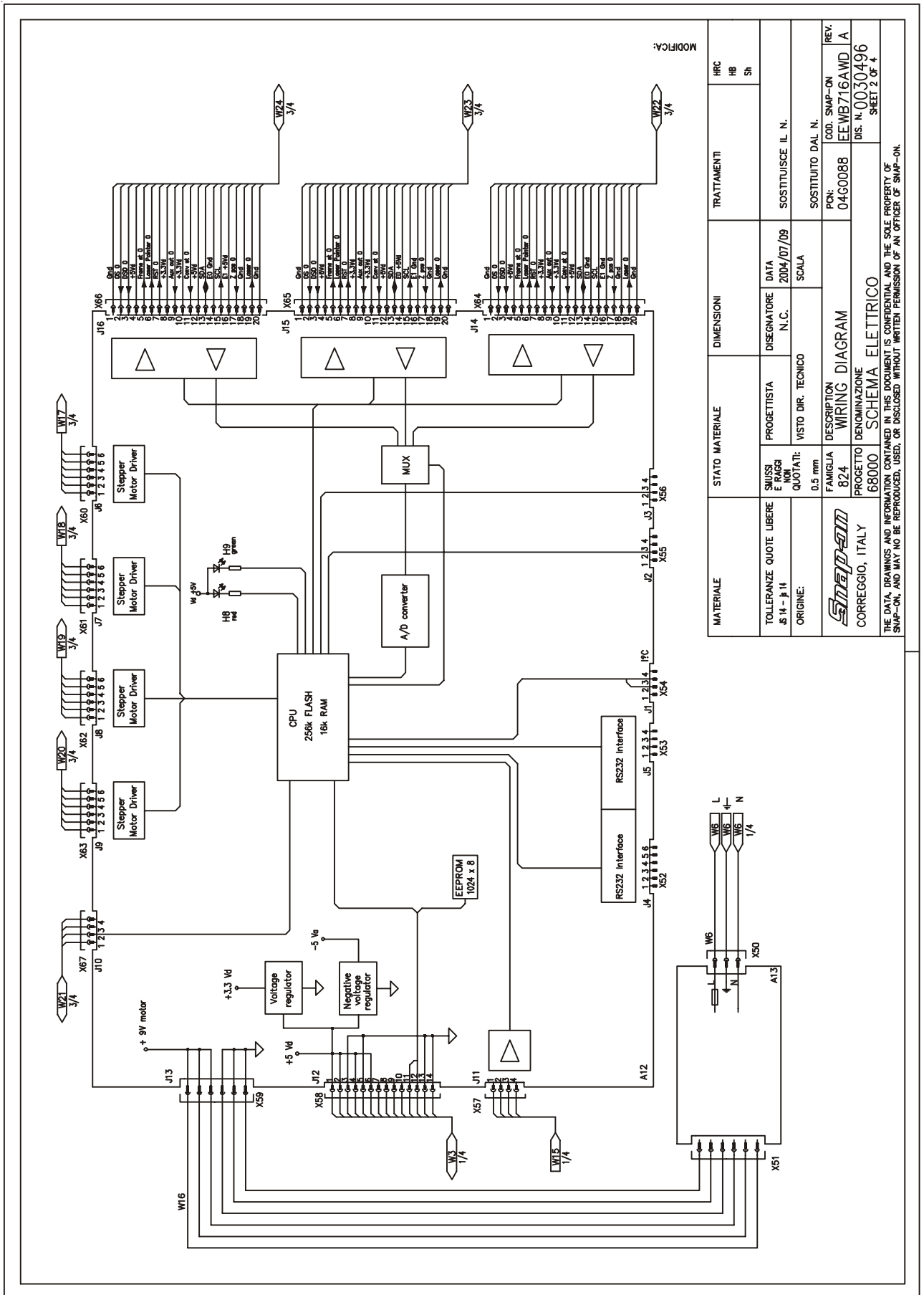

MODIFICA:

MATERIALE	STATO MATERIALE	DIMENSIONI	TRATTAMENTI	HRC
TOLLERANZE QUOTE LIBERE S 14 - j 14	PROGETTISTA VISTO DIR. TECNICO	DISSEGNAZIONE N.C.	DATA 2004/07/09	HB
ORIGINE:	QUOTATI: 0,5 mm	DESCRIZIONE FAMIGLIA 824	SCALA	Sh
<b>SINAPRO</b> CORREGGIO, ITALY	PROGETTO 68000	WIRING DIAGRAM SCHEMA ELETTRICO	SOSTITUISCE IL N. SOSTITUITO DAL N.	
THE DATA, DRAWINGS AND INFORMATION CONTAINED IN THIS DOCUMENT IS CONFIDENTIAL AND THE SOLE PROPERTY OF SNAP-ON, AND MAY NOT BE REPRODUCED, USED, OR DISCLOSED WITHOUT WRITTEN PERMISSION OF AN OFFICER OF SNAP-ON.		POC: 04C0088	REV. EEWB716AWD A	
		DIS. N. 0030496	SHEET 2 OF 4	

Electrical diagram

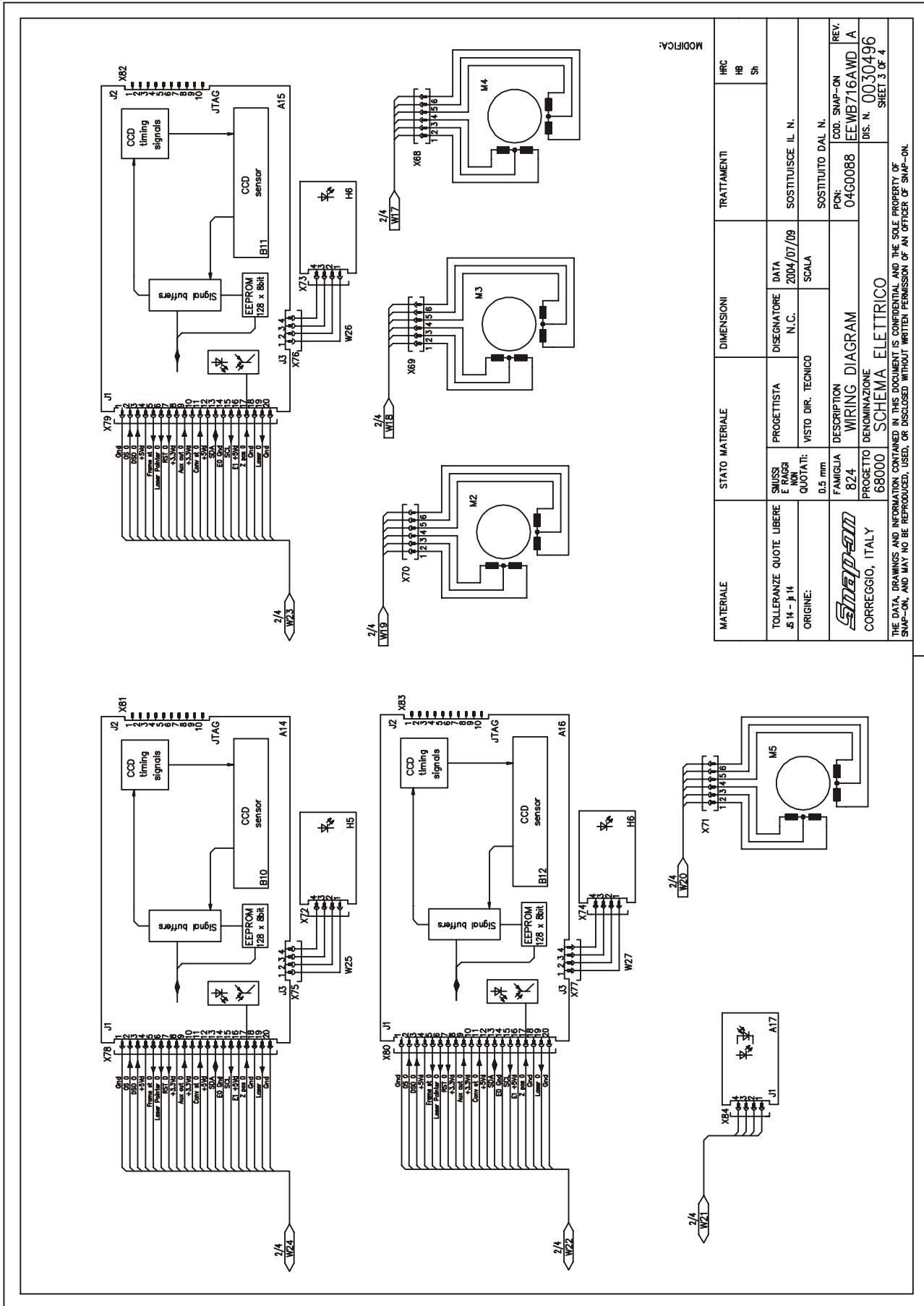

MODIFICA:

MATERIALE	STATO MATERIALE	DIMENSIONI	TRATTAMENTI	HRC
TOLLERANZE QUOTE LIBERE JS 14 - F 14	SMUSSI E RAGGI NON QUOTATI:	PROGETTISTA DESIGNATORE N.C.	DATA 2004/07/09	HB 5H
ORIGINE:	FAMIGLIA 824	VISTO DIR. TECNICO	SOSTITUISCE IL N. SCALA	
<b>SNAP-ON</b> CORREGGIO, ITALY	DESCRIPTION WIRING DIAGRAM		SOSTITUITO DAL N.	
THE DATA, DRAWINGS AND INFORMATION CONTAINED IN THIS DOCUMENT IS CONFIDENTIAL AND THE SOLE PROPERTY OF SNAP-ON, AND MAY NOT BE REPRODUCED, USED, OR DISCLOSED WITHOUT WRITTEN PERMISSION OF AN OFFICER OF SNAP-ON.		PCN: 04G0088	CCD. SNAP-ON	REV. EEWB716AWD 1A
		PROGETTO DENOMINAZIONE 68000	DIS. N.	0030496
				SHEET 3 OF 4

# Electrical diagram

MATERIALE		STATO MATERIALE		DIMENSIONI		TRATTAMENTI		HRC	
TOLLERANZE QUOTE LIBERE JS 14 - H 14	SNUISSI E INAGGI QUOTATI: 0,5 mm	PROGETTISTA VISTO DIR. TECNICO	DISIGNATORE N.C.	DATA 2004/07/09	SOSTITUISCE IL N.		SOSTITUITO DAL N.		
ORIGINE:	FAMIGLIA 824	DESCRIPTION WIRING DIAGRAM		PCN: 04G0088	COD. SNAP-ON		REV.		
	PROGETTO DENOMINAZIONE 68000	SCHEMA ELETTRICO		DIS. N. 0030496		SHEET 4 OF 4			
THE DATA, DRAWINGS AND INFORMATION CONTAINED IN THIS DOCUMENT IS CONFIDENTIAL AND THE SOLE PROPERTY OF SNAP-ON, AND MAY NOT BE REPRODUCED, USED, OR DISCLOSED WITHOUT WRITTEN PERMISSION OF AN OFFICER OF SNAP-ON.									
A1	Controller board								
A2	Power interface board								
A3	Opto electronic board								
A4	Encoder board								
A5	Embedded PC unit								
A6	Keyboard unit								
A10	Power entry module								
A12	Camera processor board								
A13	10VDC switching power supply								
A14	Camera CCD board (REAR)								
A15	Camera CCD board (OUTER)								
A16	Camera CCD board (INNER)								
A17	Opto-switch board								
B1	Temperature sensor								
B2	Piezzo rear								
B3	Piezzo front								
B4	Offset gauges, potentiometer (10k) with cable								
B5	Diameter gauges, potentiometer (10k) with cable								
B8	Incremental encoder main shaft								
B9	Incremental encoder power clamp								
B10	CCD sensor								
B11	CCD sensor								
B12	CCD sensor								
Co	Motor capacitor 10uF								
CT	Torque capacitor 20uF								
D13	Software update socket								
F1	Miniature fuse 6.3AT								
F2	Miniature fuse 6.3AT								
F3	Miniature fuse 3.2AT								
F4	Miniature fuse 3.2AT								
F5	Discharger								
F7	Miniature fuse 1.25mA								
H1	Red LED								
H2	Green LED								
H4	Monitor								
H5	Rear laser module								
H6	Outer laser module								
H7	Inner laser module								
H8	Red service LED								
H9	Green service LED								
K2	Forward run relay								
K3	Reverse run relay								
K4	Torque capacitor CT relay								
K7	Inner rim side lighting relay								
M1	Motor								
M2	Rear stepper motor (scan)								
M3	Outer stepper motor								
M4	Inner stepper motor								
M5	Rear stepper motor (transition)								
S3	Wheel guard switch								
S4	Pedal switches								
S5	Pedal switches								
T2	Step-up transformer								
W1	Power cord								
W2	Cable power entry module								
W3	Cable asm. ribbon dig. display								
W4	Vibratory system harness								
W5	Wheelguard extension wire								
W6	Main card monitor and switching								
W7	Connection wire aerial interface								
W10	Power connection assembly Embedded PC								
W11	Extension cable D-SUB 9 pole								
W15	Cable asm. encoder								
W16	Cable asm. switching power supply								
W17	Cable asm. motors inner								
W18	Cable asm. motors outer								
W19	Cable asm. motors rear (scan)								
W20	Cable asm. motors rear (transition)								
W21	Cable asm. stop								
W22	Cable asm. CCD camera inner								
W23	Cable asm. CCD camera outer								
W24	Cable asm. CCD camera rear								
W25	Cable asm. rear laser module								
W26	Cable asm. outer laser module								
W27	Cable asm. inner laser module								
Y1	Electromagnet geodata								
Y2	Electromagnetic brake (30Nm)								

MODIFICA:

MODIFIED / CHANGED PARTS Regarding Revision 02.05 (B)

**List of new chapter from this revision:**

- At page 16-17 1.4.2 TDI Tread Dept Indication
- At page 16-17 1.4.3 Print functions
- At page 28-29 9.2.1 Warning Messages in Optima Entry Screen

UPDATING REPORT

MODIFIED / CHANGED PARTS Regarding Revision 07.05 (C)

**List of new chapter from this revision:**

- At page 32-33 9.3 Optima Matching
- At page 34-35 9.4 Rim Only diagnosis
- At page 40-41 9.8 Print Report
- At page 56-57 17.5 SCA Flange
- At page 60-61 18 Printer Installation Instructions

**Information added:**

- at Chapter 9.2
- at Chapter 9.2.1
- at Chapter 9.7

**First edition in IT-ES-PT** (the Previous Revision was available in DE-GB-FR only)

UPDATING REPORT

List of the changes, introduced beginning from the revision 09.05 (D)

**Instruction added regarding software version 3.0**

- page 20-22-24 > **New Function key (F1) and (F3). Information added in (F5).**
- page 26 > **Position Brake Control.**
- page 34 > **Chapter 9.4 Rim Only Diagnosis, rewritten.**
- page 38 > **Chapter 9.7 Optima Parameters, point (m, n) rewritten, (n1,n2,n3,n4) added.**
- page 38 > **Chapter 10.1 Advanced Spoke Detection, added.**

**Replaced/New pictures:** 1.4-2 1.4-3 9.1-1 9.1-1a 9.1-2 9.1-3 9.1-4 9.1-5 F2 F3 F4 F5(9.1-6) F5(9.1-7) F5 F6 9.2-0 9.2-1 9.2-2 9.2-3 9.2.1-1 9.2.1-2 9.3-0 9.3-1 9.3.1-2 9.3.1-3 9.3.2-0 9.4-1 9.4-2 9.4-3 9.4-4 9.5-0 9.6-0 9.7-0 9.7-1 9.9-1 9.9-2 10.1-1

UPDATING REPORT

List of the changes, introduced beginning from the revision 01.06 (E)

**Additional instruction regarding software version 3.1**

- page 32 > Chapter 9.3 replace the previous release chapters 9.5 and 9.6.
- page 34 > The previous release chapter 9.3 becomes chapter 9.4.
- page 36 > The previous release chapter 9.4 becomes chapter 9.5.
- page 40 > The previous release chapter 9.7 becomes chapter 9.6. Changed description from point "m", added description for point "n" and "n2".
- page 38 > The previous release chapter 9.8 becomes chapter 9.7. Changed description at point "a", added description at point "b".
- page 50 > Replaced the error messages "E360 - E361 - E362". Added new error messages list, from "E366".

**Replaced/New pictures:** 9.6-2, 9.6-3, 9.7-1 9.7-2

UPDATING REPORT

List of the changes, introduced from the revision 04.06 (F2)

**Additional instruction regarding software version 3.2**

- page 46 > Chapter 11.0 has been added. "Optional Functions".
- page 48 > Chapter 11.1 has been added. "OPTI LINE Instruction".
- page 90 > Instruction for the Error E400 has been added.

**New pictures:** > All the pictures of the chapters Optional Functions and OPTI LINE.



## EC declaration of conformity

### EC declaration of conformity

The company

**Snap-on Equipment GmbH**  
**Geschäftsbereich Hofmann Werkstatt-**  
**Technik Werner-von-Siemens-Str. 2**  
D – 64319 Pfungstadt

declares herewith that the  
**wheel balancer**

**geodyna optima**

– Sr. No.  –

as designed, manufactured and put by us  
on the market meets relevant basic safety  
and health requirements as set forth in the  
relevant EC guide-lines for machines and  
electromagnetic compatibility as specified  
hereafter (in their latest versions):

98/37/EC  
89/336/EC

Applied harmonized and national standards:

EN 292–1, 292–2 / EN 294 / EN 349 / DIN 30 600 /  
DIN 8418 / VDE 0100 / EN 5501 /  
EN 50081-1 / EN 61000-6-2 / EN 61000-3-2 / EN 61000-3-3

This declaration becomes null and void if  
the machine is not used as set forth under  
„Scope of application” of this operation  
manual, or if any modifications or changes  
whatsoever are made to the machine  
without prior approval from our end.

ppa

  
Hans-J. Rupp  
Director Sales & Service

SOE Digital Code: OM-GEODYNA OPTIMA-04-06\_ZEEWB716A03\_RF2