EEWB308D

COMPUTER WHEEL BALANCER

FOR:

MOTORCYCLE WHEELS

OPERATION INSTRUCTIONS

Form ZEEWB308D

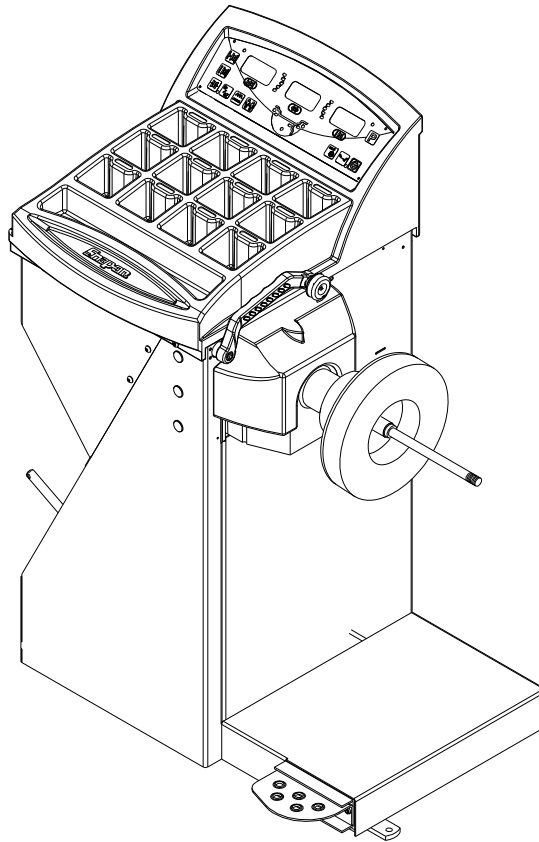

Snap-on®



SAFETY INFORMATION

**For your safety, read this manual thoroughly
before operating the Model EEWB308D Wheel Balancer**

The Model EEWB308D Wheel Balancer is intended for use by properly trained automotive technicians. The safety messages presented in this section and throughout the manual are reminders to the operator to exercise extreme caution when servicing tires with these products.

There are many variations in procedures, techniques, tools, and parts for balancing tires, as well as the skill of the individual doing the work. Because of the vast number of wheel and tire applications and potential uses of the product, the manufacturer cannot possibly anticipate or provide advice or safety messages to cover every situation. It is the automotive technician's responsibility to be knowledgeable of the wheels and tires being serviced. It is essential to use proper service methods in an appropriate and acceptable manner that does not endanger your safety, the safety of others in the work area or the equipment or vehicle being serviced.

It is assumed that, prior to using the Model EEWB308D Wheel Balancer, the operator has a thorough understanding of the wheels and tires being serviced. In addition, it is assumed he has a thorough knowledge of the operation and safety features of the rack, lift, or floor jack being utilized, and has the proper hand and power tools necessary to service the vehicle in a safe manner.

Before using the Model EEWB308D Wheel Balancer, always refer to and follow the safety messages and service procedures provided by the manufacturers of the equipment being used and the vehicle being serviced.



IMPORTANT !! SAVE THESE INSTRUCTIONS -- DO NOT DISCARD !!

IMPORTANT SAFETY INSTRUCTIONS

When using this equipment, basic safety precautions should always be followed, including the following:

1. Read all instructions.
2. Do not operate equipment with a damaged power cord or if the equipment has been damaged - until it has been examined by a qualified authorized service technician.
3. If an extension cord is used, a cord with a current rating equal to or more than that of the machine should be used. Cords rated for less current than the equipment may overheat. Care should be taken to arrange the cord so that it will not be tripped over or pulled.
4. Always unplug equipment from electrical outlet when not in use. Never use the cord to pull the plug from the outlet. Grasp plug and pull to disconnect.
5. To reduce the risk of fire, do not operate equipment in the vicinity of open containers of flammable liquids (gasoline).
6. Keep hair, loose fitting clothing, fingers and all parts of the body away from moving parts.
7. Adequate ventilation should be provided when working on operating internal combustion engines.
8. To reduce the risk of electric shock, do not use on wet surfaces or expose to rain.
9. Do not hammer on or hit any part of the control panel with weight pliers.
10. Do not allow unauthorized personnel to operate the equipment.
11. Use only as described in this manual. Use only manufacturer's recommended attachments.
12. Always securely tighten the wing nut before spinning the shaft.
13. ALWAYS WEAR SAFETY GLASSES. Everyday eyeglasses only have impact resistant lenses, they are NOT safety glasses.
14. Balancer is for indoor use only.

SAVE THESE INSTRUCTIONS

TABLE OF CONTENTS

SAFETY INFORMATION	1-2
1.0 INTRODUCTION	4
1.1 SAFETY NOTICE	4
1.2 BALANCER APPLICATION	4
1.3 EEWB308D SPECIFICATIONS	5
1.4 FEATURES	5
1.5 STANDARD ACCESSORIES	6
2.0 DIMENSIONS OF THE MACHINE	7
2.1 REQUIRED INSTALLATION AREA	7
2.2 INSTALLATION INSTRUCTIONS	7
2.3 FLANGE ADAPTER INSTALLATION	8
2.4 ARBOR INSTALLATION	8
2.5 ELECTRIC INSTALLATION	8
3.0 TERMINOLOGY	9
4.0 OPERATION OF THE BALANCER	10
4.1 CHECK LIST - INSPECTION	10
4.2 WHEEL MOUNTING	10
4.3 MODE SELECTIONS	11
4.4 SELECTING OPERATOR PREFERENCES	12
4.4.1 FINE BALANCING MODE	12
4.4.2 OUNCE/GRAMS CONVERSION	12
4.4.3 RIM DIAMETER IN MILLIMETERS	12
4.5 ENTER RIM PARAMETERS	12
4.6 CORRECTION OF THE IMBALANCE	13
4.7 VERIFICATION OF THE RESULTS	13
4.8 VIBRATION PROBLEMS	13
5.0 CALIBRATION VERIFICATION - P14	14
6.0 RIM OFFSET GAUGE CALIBRATION - P80	15
7.0 EXPLANATION OF PROGRAM CODES	16
8.0 MAINTENANCE	16
9.0 TROUBLE SHOOTING	16

1.0 INTRODUCTION

Congratulations on purchasing the **EEWB308D** computer wheel balancer. This wheel balancer is designed for ease of operation, accuracy, reliability and speed. With a minimum of maintenance and care your wheel balancer will provide many years of trouble-free operation.

Instructions on use, maintenance and operational requirements of the machine are covered in this manual.

**STORE THIS MANUAL IN A SAFE PLACE FOR FUTURE REFERENCE.
READ THIS MANUAL THOROUGHLY BEFORE USING THE MACHINE.**

1.1 SAFETY NOTICE

This manual is a part of the balancer product.

Read carefully all warnings and instructions of this manual since they provide important information concerning safety and maintenance.

1.2 BALANCER APPLICATION

*The Snap-on wheel balancer model **EEWB308D** is intended to be used as equipment to balance car, and light truck wheels within the following range:*

<i>Maximum wheel diameter</i>	<i>:</i>	<i>44" (1117mm)</i>
<i>Maximum wheel width</i>	<i>:</i>	<i>20" (508mm)</i>
<i>Maximum wheel weight</i>	<i>:</i>	<i>120lbs (54 kg)</i>

This equipment is to be only used in the application for which it is specifically designed. Any other use shall be considered as improper and abusive.

The manufacturer shall not be considered liable for possible damages caused by improper, wrong, or abusive use of this equipment.

1.3 EEWB308D SPECIFICATIONS

Computerized digital wheel balancer for car, light truck wheels.

Weight Imbalance Accuracy	.10 oz / 2 grams
Weight Placement Resolution	± .7 degrees
Weight Imbalance Resolution:	
Roundoff Mode	.25 oz / 5 grams
Non-Roundoff Mode	.05 oz / 1 gram
Max. Shaft Weight Capacity	120 lbs / 54 kg
Max. Tire Diameter	44" / 1118 mm
Rim Width Capacity	1"-20" / 25 mm - 508 mm
Rim Diameter Capacity	6"-30" / 152 mm-762 mm
Balancing Cycle Time.	15 seconds or less
Shaft Speed at calculation	119 RPM
Electrical	115 1ph, 50-60Hz, 2A
Required Work Area	60"w x 48"d 1524 x 1219 mm
Shipping Weight, unit/pallet/carton	230 lbs/77kg
Shipping Dimensions	48"h 40"w 28"d
Machine Dimensions	40"h 38"w 21"d
Actual Weight with Accessories	174 lbs / 79 kg
Operating Temperature Range	32-122F / 0-50C

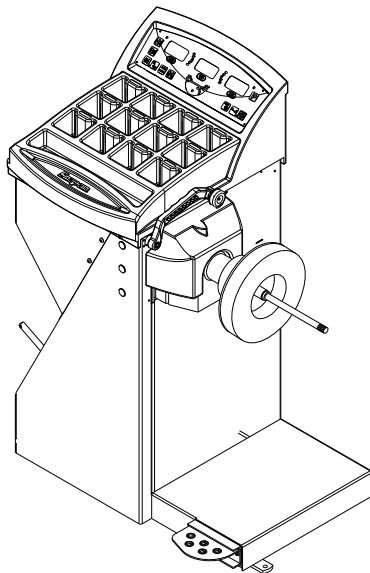

1.4 FEATURES

ACCURACY

- Weight placement accuracy is ± .7°
- Weight imbalance accuracy to 2 grams.
- Self test check with every power up cycle.
- Fast operator calibration.
- Pre-programmed Error Codes indicate procedural errors or safety concerns.

SPEED and DURABILITY

- Automatic distance entry. Simply touch the SAPE arm to the wheel, the distance parameter is automatically entered.
- Quick cycle time.
- Automatic recalculation if weight positions are changed. No need for re-spinning the wheel.
- Weight pocket storage tray.
- Easy-to-Read Data display.
- Easy weight tray access.

SOFTWARE VERSATILITY

- Both dual weight Dynamic and single weight Static capability.
- Built-in spin counter for monitoring balancer productivity.
- Service code access to all Balancer electronic functions for fast, easy diagnosis.
- Operator selectable roundoff mode.
- Ounce / Gram toggle from front panel
- Multiple operator feature allows several operators to recall wheel parameters.

1.5 STANDARD ACCESSORIES

EAK0221J13A Adapter Kit - Figure 1

Ref	Part Number	Qty	Description
1	1412	1	Spring Conical, MC
2	EAK0221J15A	1	Adapter Kit - M/C (see below)
3	3607-01	1	Spring - Conical
4	3609-01	1	Spacer - M/C Shaft
5	EAC0054P14A	1	Spin/Hand Crank Handle
6	EAM0006G16A	1	Bolt - Crank Handle (not shown)
7	8430-02	1	Caliper Accessory - M/C
8	EAA0255J43A	1	Flange Accessory
9	EAM0005D62A	1	Gauge Extension

EAK0221J15A Adapter Kit - Figure 2

10	1387	2	Cone - M/C
11	1388	1	Nut Ring - M/C
12	1389-01	2	Disc - Pressure
13	1389-02	1	Disc - Pressure
14	EAM0003J33A	1	Shaft Accessory - 14mm
15	1401	1	Spring - Adapter M/C

Additional Accessories - Figure 3

16	7-14201A	1	AC Power Adapter
17	EAM0006G01A	4	Pin - Accessory



Figure 1

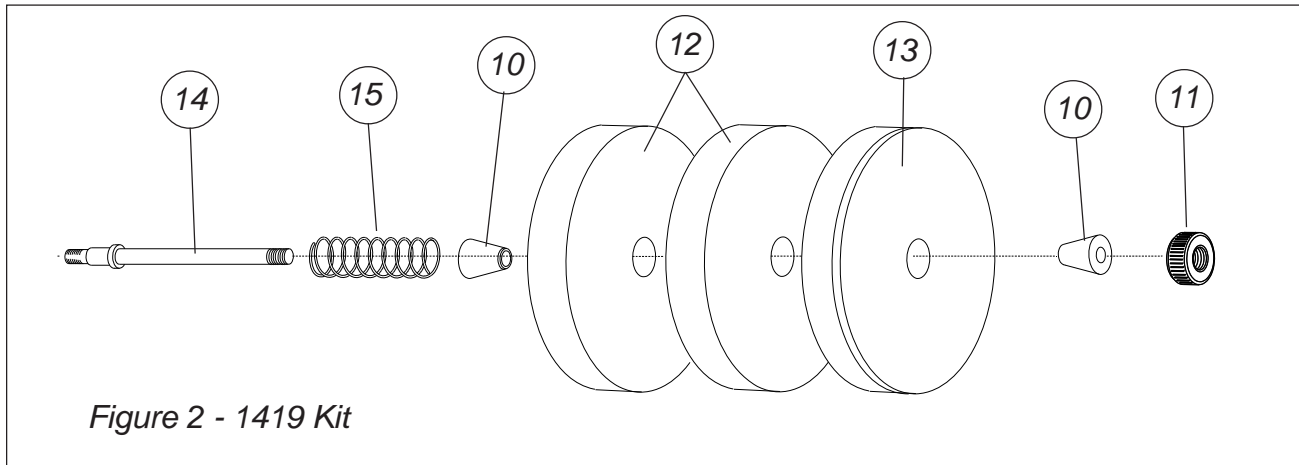

Figure 2 - 1419 Kit

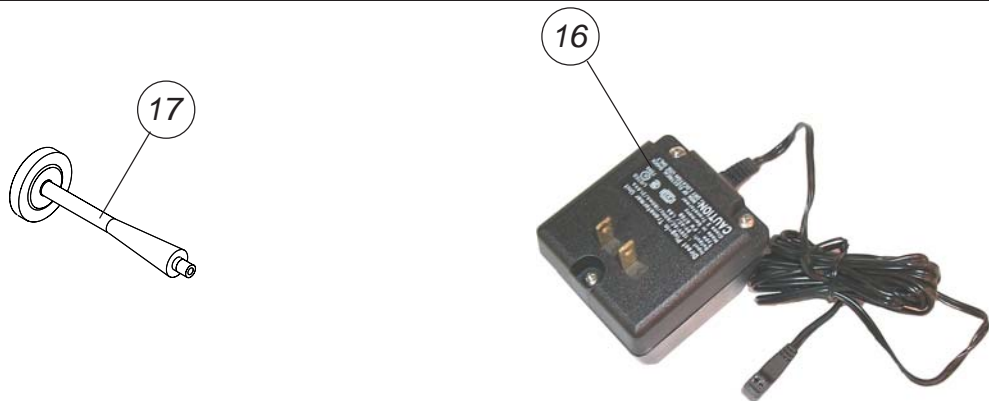

Figure 3

PRE-INSTALLATION CONSIDERATIONS

2.0 DIMENSIONS OF THE MACHINE

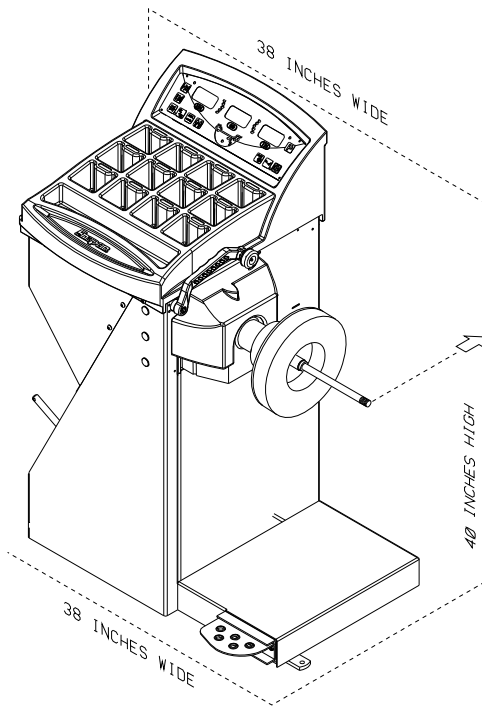

Figure 4 - Actual Footprint Dimensions.

2.1 REQUIRED INSTALLATION AREA

Make sure that from the operating position the user can see all of the machine and the surrounding area.

The operator should prevent non authorized persons and/or objects from entering the area which may create potential hazards.

The machine should be installed on a stable level floor. Do not install the machine on a uneven floor.

If the balancer is to be installed on a raised floor, the floor must have a capacity of at least 110lbs per sq ft. (5000 N/m² - 500 kg/m²).

It is not required to secure the machine to the floor.

Install the machine in a dry, covered area.

The installation of the machine requires a working area of at least 60" x 48" (1524 x 1219 mm) (Figure 5).

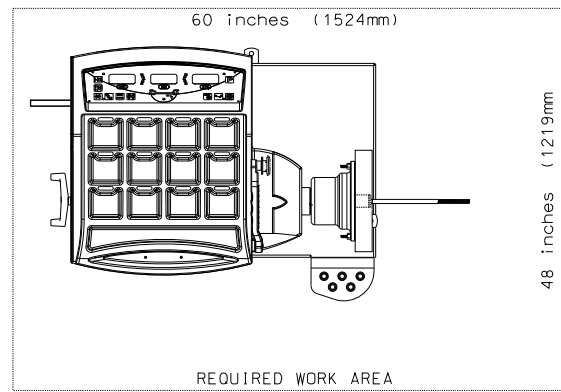

Figure 5 - Recommended Work Area

2.2 INSTALLATION INSTRUCTIONS

CAUTION! CAREFULLY REMOVE THE BALANCER FROM THE PALLET.

Remove the hardware that secures the machine to the pallet and slide the balancer onto the floor where it is to be installed.

THE UNIT IS HEAVY AND THE WEIGHT IS NOT EVENLY DISTRIBUTED.

DO NOT LIFT THE BALANCER BY THE SHAFT.

DROPPING THE UNIT MAY CAUSE PERSONAL INJURY OR EQUIPMENT DAMAGE.

A. Remove the hardware that secures the machine to the pallet and slide the balancer onto the floor where it is to be installed.

b. Locate hand crank handle and associated screw-nut and mount hand crank to the left side of the mounting shaft as shown in Figure 6. NOTE: The crank screw uses a left hand thread. Do not over-tighten. Make sure threads and mating surface is clean prior to assembly. Refer to Figure 6 for detail.

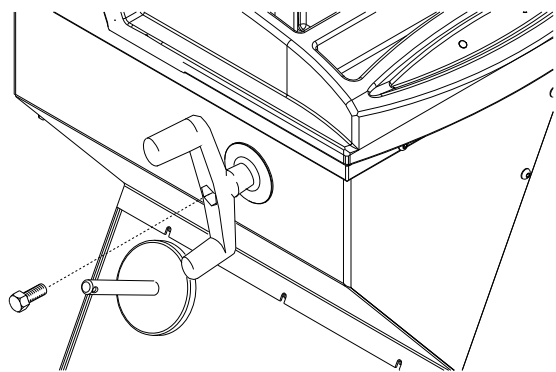

Figure 6

2.3 FLANGE ADAPTER INSTALLATION

Mount the flange adapter plate onto the shaft back plate using supplied nuts and washers. Do not over tighten. Refer to Figure 7.

2.4 ARBOR INSTALLATION

IMPORTANT!

CHECK THAT THE SURFACES ARE PERFECTLY CLEAN AND NOT DAMAGED. AN INCORRECT MOUNTING MAY RESULT IN SIGNIFICANT IMBALANCE.

Mount the threaded shaft onto the arbor of the balancer. Tighten firmly, but do not exceed 70 inch lbs. See Figure 7.

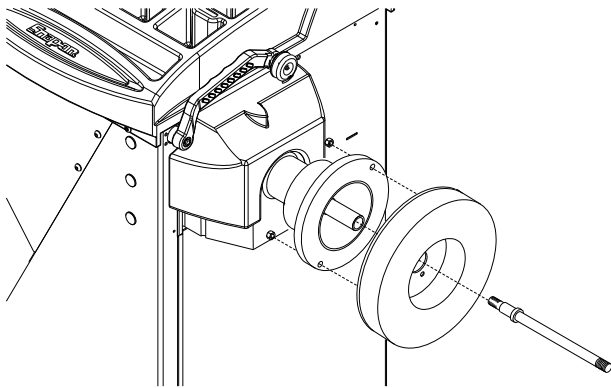

Figure 7

2.5 DISTANCE GAUGE EXTENSION

Mount the Distance gauge extension to the Distance Gauge arm. See Item 9 on page six for photo of the gauge arm extension.

2.5 ELECTRIC INSTALLATION

ANY ELECTRICAL WIRING MUST BE PERFORMED BY LICENSED PERSONNEL.

ALL SERVICE MUST BE PERFORMED BY AN AUTHORIZED SERVICE TECHNICIAN.

Check on the plate of the machine that the electrical specifications of the power source are the same as the machine. The machine uses 115VAC, 50-60Hz, 1Ph, 2.0 Ampere. Plug the AC power adapter into the receptacle on the rear of the machine. See Figure 8

NOTE:

Any electrical outlet installation must be verified by a licensed electrician before connecting the balancer.

Check that the outlet has an automatic ground fault circuit breaker with a differential circuit set at 30 mA.

NOTE:

This machine performs a self-test routine on start-up. There will be a delay of several seconds before the display is activated.

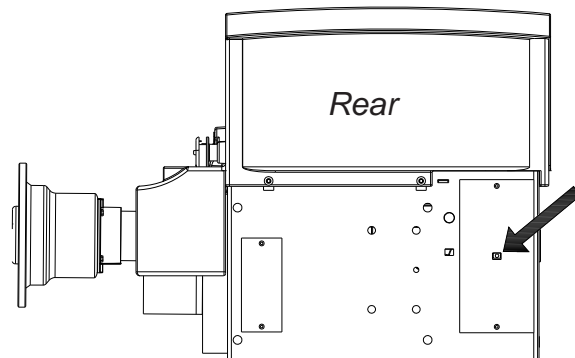

Figure 8

3.0 TERMINOLOGY

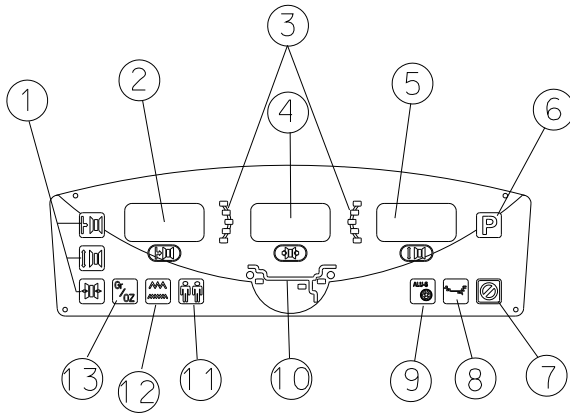

Figure 9

Before using the wheel balancer it is suggested that you become familiar with the terminology and features of the machine's components. Refer to Figures 9 and 10 for identification and location.

DISPLAY - Figure 9

1. **Parameters - Rim Offset** - Key is used to enter the rim offset position using numbers from the distance gauge. **Rim Diameter** - Enter the rim diameter. Read the size stated on the tire sidewall. **Rim Width** - Press this key to enter the rim width. Use the rim width calipers for measurement.
2. **Inside Weight Amount and Function Display Window** - Shows inside or left weight amount and various operation messages.
3. **Position Indicator LEDs** - Displays the location for wheel weight placement.
4. **Middle Display** - Used to display wheel parameters or messages.
5. **Outside Weight Amount and Function Display Window** Shows outside or right weight amount and various operation messages.
6. **Function Button** - Used to activate the various functions. Press this button followed by rotating the shaft until the desired number is displayed. Releasing the "P" button activates the function.
7. **Cancel** - Pressing this key interrupts any process.
8. **Mode Selection** - A series of placement locations for custom weight location. Useful for the wide variety of custom wheels on today's market.
9. **ALU-S and Spoke Mode** - Activates the ALU-S or Spoke Mode. Each time this button is pressed programming toggles between the two.
10. **Weight Mode and Placement Display** - Displays a pictorial reference of the chosen balance mode.

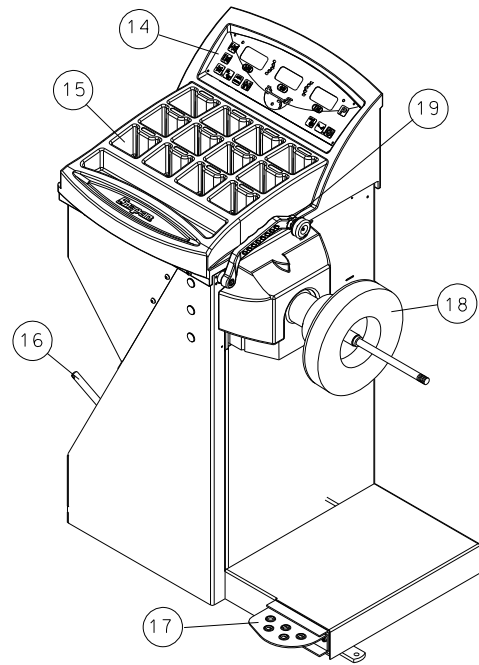

Figure 10

11. **Multi-Operator Selection** - This key toggles between four operators designated as a, b, c, and d. Wheel parameters are recalled upon command.
12. **Fine Weight Toggle** - In normal mode "FIN OFF" round off is 0.25 oz or 5 gram, fine mode "FIN ON" round off is 0.05 oz. or 1 gram.
13. **Oz/Gr** - Toggles between display values in Ounces or Grams.

CABINET - Figure 10

14. **Display** - Easy to read, user friendly display featuring large LEDs and one button functions.
15. **Weight Storage Tray** - Generous storage for a variety of weight profiles and sizes as well as built in storage pockets for the standard centering cones.
16. **Accessory Storage** - Four sturdy side mounted pegs are supplied for storage of additional accessories.
17. **Foot Operated Shaft Lock** - A foot operated shaft lock is used to stabilize the shaft during the weight placement process.
18. **Shaft Adapter** - Flange and 14mm shaft made for balancing Motor Cycle wheels.
19. **Semi-Automatic Parameter Arm** - Rim distance is automatically input with the SAPE. The SAPE is also used in several procedures for determining accurate rim profiles.

4.0 OPERATION OF THE BALANCER

WARNING: For operator safety please read and follow the precautions outlined on pages 1 and 2 of this manual.

NOTE: Read all instructions before proceeding with operation of the balancer.

All balancer functions are input into the main computer through the large easy to read touch panel. Although each wheel tire assembly differ in some ways all balancing jobs require basically the same procedure. The order of events to take place are:

1. Inspection of the wheel/tire assembly
2. Selection of proper cones or mount
3. Mounting wheel onto shaft or adapter
4. Selection of Balancing Mode or placement
5. Entry of wheel parameters
6. Spinning the wheel
7. Applying the recommended weight
8. Check spin if desired
9. Dismounting the wheel

The following operation instructions will follow the basic outline above.

4.1 CHECK LIST - INSPECTION

Observe Before Balancing Wheel

1. Check for proper air pressure. If not correct, inflate to correct pressure.
2. Check for any foreign material inside tire. If present, remove before balancing tire.

WATER IS FOREIGN MATERIAL!

3. Remove old weights — old weights may be improper value or in wrong location.
4. Be sure tire and wheel are free of excessive dirt, rust and large stones.
5. Be sure that the right size tire has been mounted on the wheel.

4.2 WHEEL MOUNTING

4.2.1 Standard MC Wheels

Perform an P4 adapter calibration:

- A. Mount Adapter to be compensated.
- B. Press and hold **P**, while turning Diameter/Function knob until **4** is displayed, when the **P** button is released, the function will activate.
- C. When P4 activates, display reads: “**CAL ADP**”- for 1 second, followed by: “**SPN 1**”
- D. Hand spin the shaft using the left side hand crank. The display reads “**CAL 1**” while the machine is doing calculations. Do not disturb the machine during calculations. Do not tap on or touch the machine. After calculations, shaft is stopped and displays: “**CAL ADP FIN**” for one second. Continue with motorcycle wheel mounting and balancing procedures.

WARNING:

Before performing balancing procedures, inspect the wheel and tire for proper size match. Inspect tire carcass for imperfections, signs of damage, tire plugs, cracks or any other imperfection that could create a hazard in a high performance application.

WARNING:

Always wear proper safety glasses when using a tire balancer. Remove any loose weights before proceeding. Spinning wheel assemblies could cause loose weights to dislodge and strike the operator. Do not allow bystanders near the machine when in operation.

1. Slide a compression spring and centering cone onto the spindle.
2. Select additional pressure discs if required, and slide them over the spindle, cone and compression spring. When using the laminated pressure disc, always face the laminated side toward the wheel. See Figure 11.
3. Place the Motorcycle wheel over the spindle, with the brake rotor or closed side of drum facing the pressure disc.

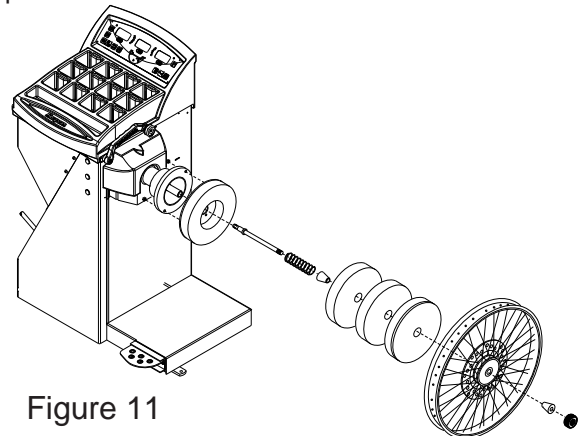

Figure 11

4. Slide the other cone onto the spindle.
5. Make sure the wheel is centered on both cones. Moderately tighten the ring nut with only enough pressure to prevent the wheel from slipping when the brake is applied. To avoid excessive wear on the pressure disc, do not overtighten the ring nut.

NOTE: When powered on, the machine defaults to the motorcycle wheel balancing (MCWB) mode. In the event the mode has been changed, enter P20 to activate the MCWB mode. If P4 adapter calibration has not been performed first, the machine will not enter the MCWB mode and display “do P4” to remind the operator to perform P4 first.

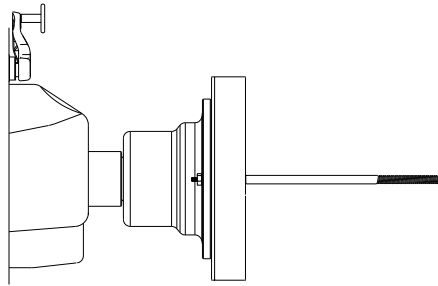

Figure 12

6. To perform a “P4” compensation, first mount the Flange assembly to the shaft as shown in Figure 12. Enter “P4” and press Enter. Then spin the shaft until a tone is heard. A second tone will sound as the shaft brakes to a stop. The adapter is now compensated. See Figure 12.
7. Use SAPE to enter the distance value. Or enter the values manually using the distance gauge scale and by rotating the shaft to enter the desired value. **NOTE:** The display value matches the value read on the gauge rod, however, the actual value entered adds 100 mm to the calculation. See Figure 13.

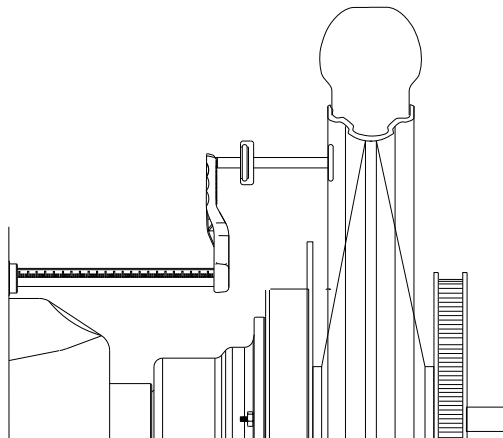

Figure 13

8. Use left and right knobs to enter the width and diameter values.
9. Spin shaft and wheel assembly with the left crank handle up to speed until the tone alert sounds.

NOTE: Disregard any pressure disc runout that may occur. The pressure discs are made of lightweight material and will not affect balancing accuracy.

10. Allow the wheel to spin freely until a second tone is heard. After calculations, the automatic brake will stop the wheel. **NOTE:** Do not lean on the balancer while the wheel is spinning, doing so can cause inaccurate readings.

NOTE: Do not use the foot operated shaft lock as a brake, it is intended to be used only to prevent shaft rotation while placing corrective weights.

11. After the wheel stops, slowly rotate the wheel by hand until center position LED lights. Hold the wheel in this position using the foot brake.

12. Note the displayed imbalance, and place this amount of weight at top dead center.

4.3 MODE SELECTIONS

NOTE: While most “Aluminum” modes are used primarily for automotive applications some can be utilized on wide or “Fat” wheels used on today’s custom motorcycles.

Static unbalance

With purely static imbalance the center of gravity and thus the principal axis of inertia of the wheel is not on the axis of rotation. Due to the unbalanced mass the wheel has a heavy and light side related to the axis of rotation. Static imbalance is compensated for by fitting counterbalance weights to the light side of the wheel, either in the center or on the sides of the rim.

Dynamic unbalance

With purely dynamic imbalance the center of gravity of the wheel is on the axis of rotation, but the principal axis of inertia is inclined relative to the axis of rotation. The unbalanced masses are diagonally opposed to each other and of equal size. To compensate for dynamic imbalance each side of the wheel is considered separately and the imbalances are compensated for separately on each side of the wheel.

Dynamic imbalance is not significant for narrow motor-cycle wheels up to a nominal width or weight separation of 3 inches or less. For these wheels static balancing is sufficient. The majority of MC balancing takes place in the default static mode which is displayed as "STA". Bullet, clip or stick-on weights will be placed on the center of the rim.

If required, select an optional weight placement mode by pressing the *Mode* button until the appropriate placement mode is displayed.

4.4 SELECTING OPERATOR PREFERENCES

4.4.1 FINE BALANCING MODE

This balancer measures with the maximum precision available all the time, 1g / 0.05 oz, however values below 5g / 0.25 oz are shown as zero while in the normal operating mode. Values exceeding 5g / 0.25 oz are rounded to the amount of the nearest commercial wheel weight.

Press the **NORMAL/FINE** button to toggle the display resolution between 5g / 0.25 oz and 1g / 0.05 oz.

4.4.2 OUNCE/GRAMS CONVERSION

When the machine is first turned on it is preset to display the imbalance in ounces.

Press the **OUNCE/GRAM** button to toggle the display between weight in ounces and grams

4.4.3 RIM DIAMETER IN MILLIMETERS

The rim diameter is normally displayed in inches, however if the value in millimeters is desired, press and hold the **P** button while rotating the shaft until "P 7" is displayed".

Repeat the above operation to convert back to inches.

Example: "dIA ICH" = inches
"dIA ---" = millimeters

4.4.4 OPERATOR SELECTION

Select the desired operator designated A,B,C, or D. The Balancer can store wheel parameters of four operators. The Operator button toggles between the four operators with each depression.

4.5 ENTER RIM PARAMETERS

4.5.1 Distance (rim offset) - Move the rim offset gauge arm to the edge of the rim, touch the pointer to the rim

edge (where a clip weight would be applied) and hold steady for about a second. The beeper will sound and the distance values will be entered automatically. Return the arm to its fully in and down position on the balancer. Do not allow the measurement arm to "dangle" down in front of the balancer.

Manual Distance Entry - In the event of automatic gauge failure, the distance value can be input manually. Move the distance gauge arm to touch the inner edge of the wheel where weights are to be placed and observe the reading on the scale of the distance gauge. Press manual wheel distance button  while rotating the shaft until value is displayed in the left display window.

NOTE: For precision balancing of performance wheels, an "ALU-S" Mode is available for precision determination of wheel parameters. This feature allows exacting placement of corrective weights as well.

4.5.2. Measure rim width using rim width calipers. Measure wheel where corrective clip-on weight would be applied. Enter the measured width by rotating the shaft until the desired value appears in the left display.

4.5.3. Rim Diameter - Read the rim diameter marked on the sidewall of the tire. Enter the measured rim diameter by rotating the shaft until the desired value appears in the right display.

4.6 CORRECTION OF THE IMBALANCE

NOTE: Before spinning the wheel make sure proper eye protection is worn by all personnel in the vicinity of the balancer.

A. Use left hand crank handle to spin the wheel up to speed. A tone will sound when sufficient speed is attained. When the balancing cycle is completed the wheel will stop automatically and the imbalance values will appear on the LED's.

NOTE: Do not use the foot operated shaft lock as a brake, it is intended to be used only to prevent shaft rotation while placing corrective weights.

B. Read the imbalance value on the outer display. Values are displayed in ounces but can be displayed in grams if required and are automatically rounded to the nearest commercial wheel weight.

Turn the wheel until the displays of the outer plane imbalance position indicator are illuminated green. Apply the wheel weight at twelve o'clock position. Use the foot operated shaft lock to prevent shaft rotation while placing weights.

C. Correct the imbalance on the inner plane in the same manner.

4.7 VERIFICATION OF THE RESULTS

Spin the wheel again and check that the readout is "0.00" "0.00" If a residual imbalance is displayed:

A. Check the rim parameters, if entered value is incorrect, correct as needed. Imbalance values will be re-computed after re-spinning wheel.

B. Check if the balancing mode selected is the most appropriate. If not, choose the right mode and respin.

C. The wheel weight could have been placed at a wrong position. To check this, position the wheel at the correction position for the outer plane. If the wheel weight previously attached is in sector 'L' or 'R' (Figure 14), move the wheel weight up about 1" (2.54cm).

If the wheel weight is in sector 'D' cut a piece of the wheel weight of an approximate value corresponding to the value shown on the right display, or replace the wheel weight with a lighter one.

If the wheel weight is in sector 'U' add a weight of value indicated by the display or replace the wheel weight with a heavier one. Repeat the same operation for the inner plane.

NOTE: If this situation is repeated, your machine may be out of calibration and a calibration operation might be required as instructed on page 14.

D. If an *ALU* function was selected ensure that the wheel weights have been placed in accordance to the program chosen.

E. Check that the quick nut is tight and that the wheel is not slipping against the backing collar.

F. Check that the wheel and adaptors are clean.

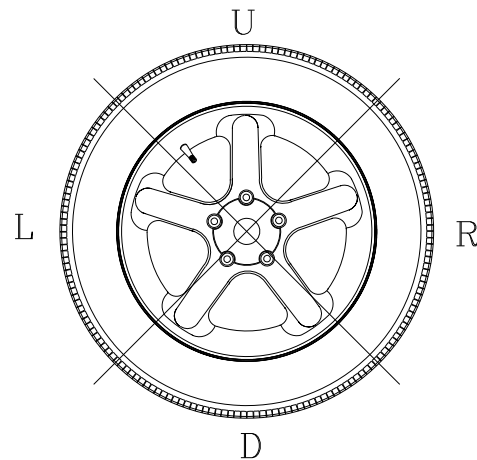

Figure 14

4.8 VIBRATION PROBLEMS

If vibration is still present after balancing, check the following possible sources of vibration:

1. Stones caught in the tire tread.
2. Tire slippage on the wheel.
3. Incorrectly mounted wheel.
4. Imbalanced wheel covers.
5. Excessive radial or lateral runout in the tire or wheel.
6. Damaged wheel bolt holes.
7. Worn universal joints.
8. Imbalanced brake rotors or drums.
9. Worn or damaged balancer accessories.

5.0 CALIBRATION VERIFICATION - P14

The EEWB308D Balancer features a user calibration verification program which requires only a few minutes to complete. Perform this procedure when the balancer has been moved, disturbed, or whenever accuracy is questioned. Using calibration verification will ensure years of reliable service. If the P80 distance calibration has not been performed, do so before proceeding with P14 checks.

Follow these 3 simple steps:

1. Activate Calibration Verification. Press and hold the **P** button while rotating the shaft until the display reads "P" "14". See Figure 15 item "1".

- Once P14 activates, the display will read "CAL" "GAN" for one second.
- The display will then read "SPN" " 1".
- Mount a balanced wheel assembly.

2. Spin shaft with wheel only - Figure 16

- Spin shaft CW, when standing in front of wheel.
- Displays "SPN" "UP" when shaft reaches 60 rpm.
- Displays "COA" "ST" with a beep if shaft speed has exceeded 120 rpm and will continue until speed drops to 119 rpm.
- Displays "CAL" " 1" when the speed drops to 119 rpm. The machine is taking data and doing calculations. After taking data, shaft is automatically braked to a stopped.
- Displays "SPN" " 2" when shaft stops.

3. Spin shaft with calibration slug on the left side.

Mount calibration slug to shaft. See Fig 17.

- Displays "SPN" "UP" when shaft reaches 60 rpm.
- Displays "COA" "ST" with a beep if shaft speed has exceeded 120 rpm and will continue until speed drops to 119 rpm.
- Displays "CAL" " 2" when the speed drop down to 119 rpm. At this moment the machine is taking data and doing calculation work. After taking data, shaft is automatically stopped.
- Displays "CAL" "FIN" when the second step of calibration is finished and machine says the calibration result is *FINE*.
- Displays "---" "---" when shaft stops and machine is in the idle state.

NOTE: Error messages will be displayed in the event problems are indicated during the calibration verification process. In the event of errors, contact your service representative.

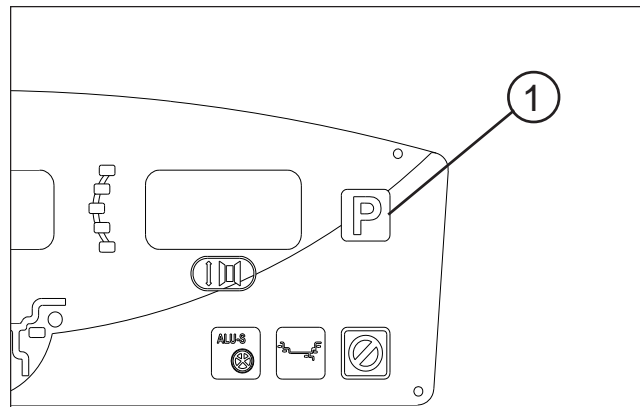

Figure 15

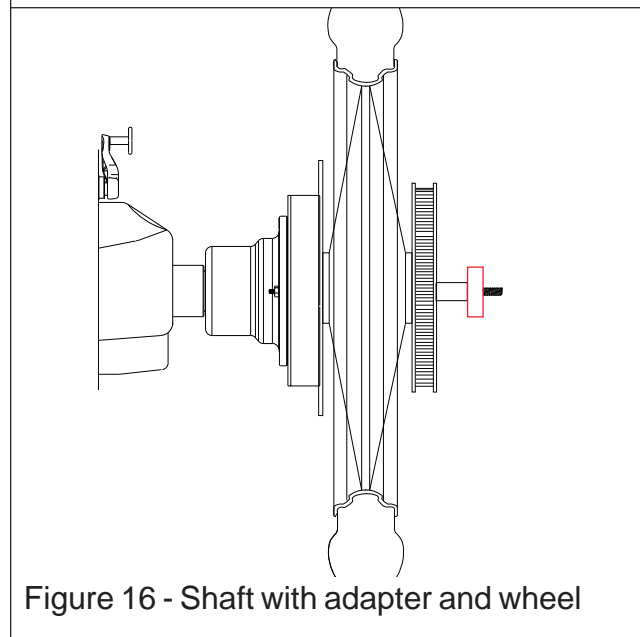

Figure 16 - Shaft with adapter and wheel

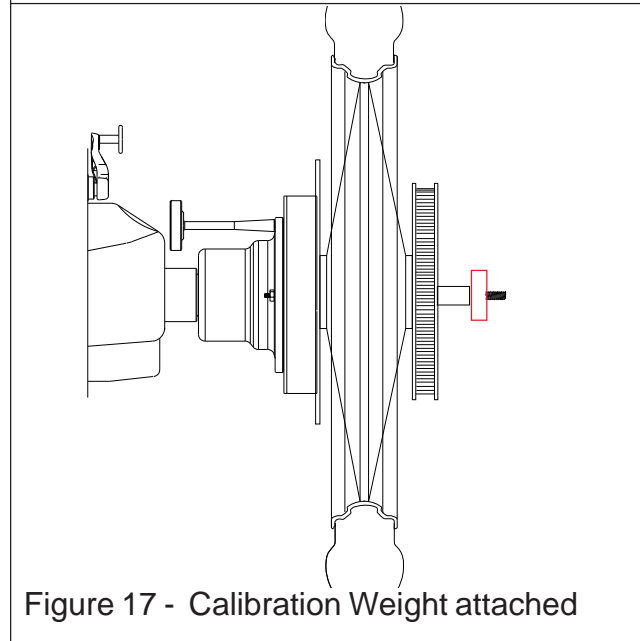

Figure 17 - Calibration Weight attached

6.0 RIM OFFSET GAUGE CALIBRATION, P80

To recalibrate the Rim Offset gauge proceed as follows:

1. Make sure the Rim Offset Gauge Arm is at home position and no adapter or wheel is mounted as shown in Figure 18.

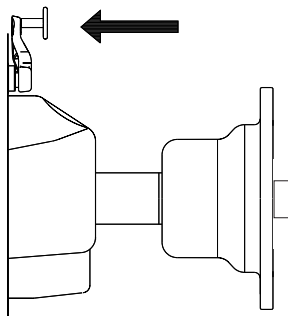

Figure 18

2. Activate the gauge calibration program, "P 80" by pressing and holding P button and rotate the shaft until 80 is displayed on right display window.
3. The right display will read "CAL SAP" for one second. This means CALibration SAPE. Then it displays "SAP OUT". The SAPE calibration procedure is activated.
4. Gently pull the SAPE arm OUT until it is fully extended, Figure 19, hold it steady for about 1 second.

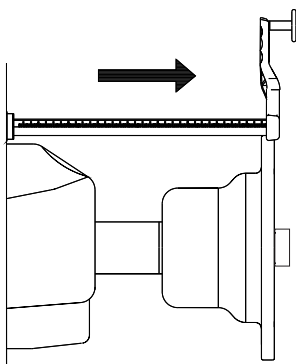

Figure 19

5. The display will now read "H POS" with a short beep sound. This is a reminder to return the arm back to its Home POSition.
6. Once the Rim Offset Gauge Arm is returned to its home position, machine displays "GOOD" with a confirmation beep. The calibration is finished.

7.0 EXPLANATION OF PROGRAM CODES

Various functions and features can be programmed to enhance operation. These programs are referred to as "P Codes". Activate the "P Code" programs by pressing and holding the **P Button** while turning the shaft until the desired number is displayed on the right display window. User Codes are explained as follows:

- P1 Toggle between normal and fine mode.
- P4 Adapter compensation mode
- P3 Toggle switch between gram and ounce display
- P12 The balancer has 4 counters that keeps track of total number of cycles for a certain parameter. The balancer will automatically cycle through the counters after P12 is pressed. The order of the counters are:
 1. Display "**Ctr ALL**" for one second.
Counter number of all spins.
 2. Display "**Ctr CAL**" for one second.
Counter number of spins since last calibration.
 3. Display "**Ctr SrV**" for one second.
Counter number of service spins.
 4. Display "**Ctr USR**" for one second.
Counter number of user spins.
- P14 Shaft Calibration verification
- P18 ALU-S mode (press balancing mode button to exit and back to DYN mode)

- P20 Motorcycle mode
- P43 Read or reset operator counters, reads or allows reset of all four operators. (A, B, C, D)
- P44 Read or reset productivity of user. Display counter number of default user only.

8.0 MAINTENANCE

BEFORE ANY MAINTENANCE OR REPAIRS ARE ATTEMPTED THE MACHINE MUST BE DISCONNECTED FROM THE ELECTRIC SUPPLY.

This balancer does not require any special maintenance, but the following precautions are required:

- A.** Periodically wash all plastic parts with a glass cleaner. Wipe with a dry cloth.
- B.** Clean all adapters regularly with a nonflammable liquid detergent all. Lubricate with a thin layer of oil.
- C.** Periodically perform a routine calibration as outlined on pages 14 and 15 of this manual.

9.0 TROUBLE SHOOTING

<u>TROUBLE</u>	<u>CAUSE</u>	<u>REMEDY</u>
When turning the machine on, the displays do not light	No electric power Defect in the electric/electronic system	Check the input voltage Call the Local Service Rep for assistance
The machine gives random readouts.	Machine unstable on the floor Water in the tire Loose adaptor Defective electronic board	Check that machine is stable Remove water from tire. Tighten the adaptor firmly Call the Local Service Rep for assistance
The machine does not stop after balancing cycle	Defective electronic component	Stop using the machine immediately and call the Local Service Rep
The balancer is slow to display when powering machine up.	This machine performs a self-test routine on start-up. There will be a delay of several seconds before the display is activated.	This is a normal characteristic of the machine
If the parameter arm ceases to properly measure rim distance causing machine lockup.	Malfunction of the Parameter arm from either a failure of the electrical system or harness connection failure.	Replace the Parameter arm or manually enter the parameters to continue operation.

NOTES:



Snap-on Equipment Services
2801 80th Street
Kenosha, WI 53141 - 1410

For Service Call:
1-800-225-5786

Notice: The information contained in this document is subject to change without notice. Equipment Services makes no warranty with regard to this material. Equipment Services shall not be liable for errors contained herein or for incidental consequential damages in connection with furnishings, performance, or use of this material.

This document contains proprietary information which is protected by copyright and patents. All rights are reserved. No part of this document may be photocopied, reproduced, or translated without prior written consent of Equipment Services.

Snap-on is a registered trademark of Snap-on Inc.