

---

# EEWB332A

## MOTORIZED WHEEL BALANCER

FOR:  
**PASSENGER CAR & LIGHT TRUCK WHEELS**

OPERATION INSTRUCTIONS



Step-by-step how  
to use instructions

---

The Snap-on logo, featuring the brand name in a stylized, italicized, metallic font with a registered trademark symbol.

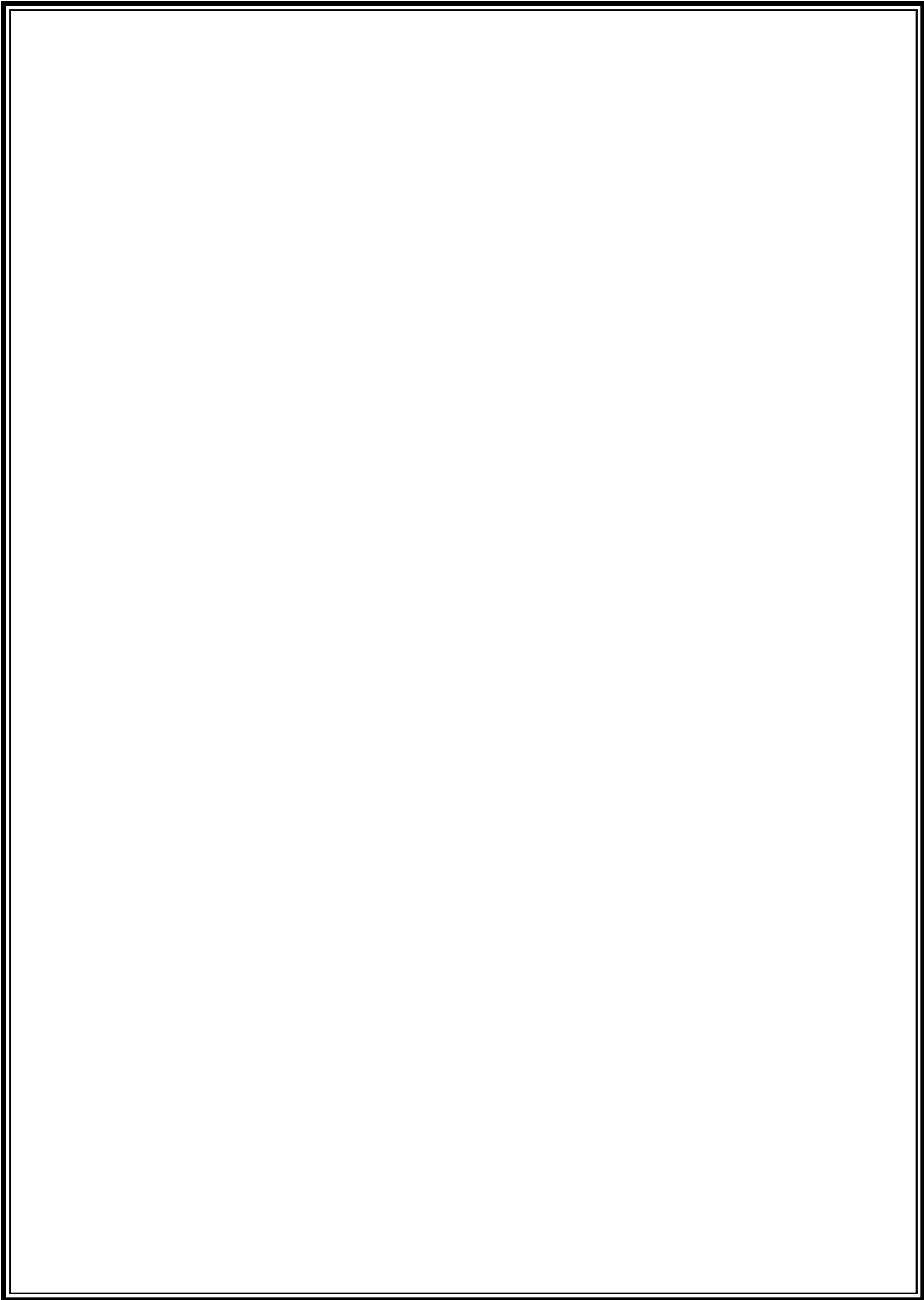

# SAFETY INFORMATION

---

**For your safety, read this manual thoroughly  
before operating the Model EEWB332A Wheel Balancer**

The Model EEWB332A Wheel Balancer is intended for use by properly trained automotive technicians. The safety messages presented in this section and throughout the manual are reminders to the operator to exercise extreme caution when servicing tires with these products.

There are many variations in procedures, techniques, tools, and parts for balancing tires, as well as the skill of the individual doing the work. Because of the vast number of wheel and tire applications and potential uses of the product, the manufacturer cannot possibly anticipate or provide advice or safety messages to cover every situation. It is the automotive technician's responsibility to be knowledgeable of the wheels and tires being serviced. It is essential to use proper service methods in an appropriate and acceptable manner that does not endanger your safety, the safety of others in the work area or the equipment or vehicle being serviced.

It is assumed that, prior to using the Model EEWB332A Wheel Balancer, the operator has a thorough understanding of the wheels and tires being serviced. In addition, it is assumed he has a thorough knowledge of the operation and safety features of the rack, lift, or floor jack being utilized, and has the proper hand and power tools necessary to service the vehicle in a safe manner.

Before using the Model EEWB332A Wheel Balancer, always refer to and follow the safety messages and service procedures provided by the manufacturers of the equipment being used and the vehicle being serviced.



**IMPORTANT !! SAVE THESE INSTRUCTIONS -- DO NOT DISCARD !!**

## **IMPORTANT SAFETY INSTRUCTIONS**

When using this equipment, basic safety precautions should always be followed, including the following:

- 1. Read all instructions.**
- 2. Do not operate equipment with a damaged power cord or if the equipment has been damaged - until it has been examined by a qualified authorized service technician.**
- 3. If an extension cord is used, a cord with a current rating equal to or more than that of the machine should be used. Cords rated for less current than the equipment may overheat. Care should be taken to arrange the cord so that it will not be tripped over or pulled.**
- 4. Always unplug equipment from electrical outlet when not in use. Never use the cord to pull the plug from the outlet. Grasp plug and pull to disconnect.**
- 5. To reduce the risk of fire, do not operate equipment in the vicinity of open containers of flammable liquids (gasoline).**
- 6. Keep hair, loose fitting clothing, fingers and all parts of the body away from moving parts.**
- 7. Adequate ventilation should be provided when working on operating internal combustion engines.**
- 8. To reduce the risk of electric shock, do not use on wet surfaces or expose to rain.**
- 9. Do not hammer on or hit any part of the control panel with weight pliers.**
- 10. Do not allow unauthorized personnel to operate the equipment.**
- 11. Do not disable the hood safety interlock system or bypass the intended operation.**
- 12. Use only as described in this manual. Use only manufacturer's recommended attachments.**
- 13. Always securely tighten the wing nut before Spinning the shaft.**
- 14. ALWAYS WEAR SAFETY GLASSES. Everyday eyeglasses only have impact resistant lenses, they are NOT safety glasses.**
- 15. Balancer is for indoor use only.**

**SAVE THESE INSTRUCTIONS**

## TABLE OF CONTENTS

SAFETY INFORMATION.....	3
1.0 INTRODUCTION .....	6
1.1 SAFETY NOTICE .....	6
1.2 BALANCER APPLICATION .....	6
1.3 EEWB332A SPECIFICATIONS .....	7
1.4 FEATURES.....	7
1.5 STANDARD ACCESSORIES .....	8
1.6 OPTIONAL ACCESSORIES.....	8
1.7 DIMENSIONS OF THE MACHINE .....	9
1.8 REQUIRED INSTALLATION AREA.....	9
1.9 INSTALLATION INSTRUCTIONS .....	9
2.0 BALANCER INSTALLATION .....	9
2.2 ELECTRIC INSTALLATION.....	10
2.3 MONITOR FRAME INSTALLATION .....	10
2.4 INSTALLATION OF THE HOOD GUARD.....	11
3.0 TERMINOLOGY .....	13
4.0 OPERATION OF THE BALANCER .....	14
4.1 CHECK LIST - INSPECTION .....	14
4.2 WHEEL MOUNTING .....	14
4.2.1 STANDARD WHEELS (BACK CONE MOUNT).....	14
4.2.2 CENTERING LIGHT-TRUCK WHEELS .....	15
4.2.3 WHEEL MOUNTING REQUIRING SPECIAL TOOLING.....	15
4.3 MODE SELECTION .....	16
4.3.1 WEIGHT PLACEMENT MODES .....	16
4.3.2 SELECTING THE ALU TYPES .....	17
4.4 SELECTING OPERATOR PREFERENCES .....	18
4.4.2 OUNCE/GRAMS CONVERSION .....	18
4.4.3 RIM DIAMETER IN MILLIMETERS.....	18
4.5 ENTER RIM PARAMETERS .....	18
4.6 CORRECTION OF THE IMBALANCE .....	20
6.0 SPOKE BALANCING MODE.....	22
6.1 SPLIT WEIGHT MODE (SWM) .....	22
7.0 USER CALIBRATION .....	23
8.0 USER FUNCTIONS.....	24
8.30 WEIGHT UNIT TOGGLE MODE .....	25
8.40 DIMENSION UNIT TOGGLE MODE .....	25
9.0 OPTIMIZATION/WEIGHT MINIMIZATION .....	26
10.0 TROUBLE SHOOTING .....	34
10.1 SYSTEM MESSAGES.....	35
10.1.1 C CODES .....	35
10.1.2 E-CODES .....	37
10.1.4 H CODES - WARNING.....	39

## 1.0 INTRODUCTION

Congratulations on purchasing the **EEWB332A** motorized wheel balancer. This wheel balancer is designed for ease of operation, accuracy, reliability and speed. With a minimum of maintenance and care your wheel balancer will provide many years of trouble-free operation.

Instructions on use, maintenance and operational requirements of the machine are covered in this manual.

**STORE THIS MANUAL IN A SAFE PLACE FOR FUTURE REFERENCE.  
READ THIS MANUAL THOROUGHLY BEFORE USING THE MACHINE.**

## 1.1 SAFETY NOTICE

This manual is a part of the balancer product.

Read carefully all warnings and instructions of this manual since they provide important information concerning safety and maintenance.

## 1.2 BALANCER APPLICATION

*The Snap-on wheel balancer model **EEWB332A** is intended to be used as equipment to balance car and light truck wheels within the following range:*

<i>Maximum wheel diameter</i>	<i>:</i>	<i>42" (1067mm)</i>
<i>Maximum wheel width</i>	<i>:</i>	<i>20" (508mm)</i>
<i>Maximum wheel weight</i>	<i>:</i>	<i>154 lbs / 69.8 kg</i>

*This equipment is to be only used in the application for which it is specifically designed.  
Any other use shall be considered as improper and abusive.*

*The manufacturer shall not be considered liable for possible damages caused by improper, wrong, or abusive use of this equipment.*

### 1.3 EEWB332A SPECIFICATIONS

Motorized digital wheel balancer for car, light truck wheels.

Weight Imbalance Accuracy	.10 oz. / 2.8 grams
Weight Placement Resolution	± .7 degrees
Weight Imbalance Resolution:	
Roundoff Mode	.25 oz. / 5 grams
Non-Roundoff Mode	.05 oz. / 1 gram
Max. Shaft Weight Capacity	154 lbs / 69.8 kg
Max. Tire Diameter	42" / 1067 mm
Rim Width Capacity	3"-20" / 76 mm - 508 mm
Rim Diameter Capacity	8"-30" / 152 mm-762 mm
Balancing Cycle Time.	6-8 seconds
Shaft Speed at calculation	200 RPM
Electrical	115vac, 1ph, 60Hz, 10A
Required Work Area	100" x 67" (2540 x1702 mm)
Shipping Weight, complete	366 lbs (166 kg)
Shipping Dimensions	62" x 64" x 44"
Machine Dimensions	(HxWxD) 70" x 59" x 45"
Actual Weight with Accessories	325 lbs / 147.4 kg
Operating Temperature Range	32-122F / 0-50C



### 1.4 FEATURES

#### ACCURACY

- Weight placement accuracy is ± .7°
- Weight imbalance accuracy to 2.8 grams.
- Self test check with every power up cycle.
- Fast operator calibration.
- Pre-programmed Error Codes indicate procedural errors or safety concerns.

#### SPEED and DURABILITY

- Automatic distance and diameter entry. Simply touch the SAPE arm to the wheel, the distance and diameter parameters are automatically entered. Width is automatically entered using a Sonar sonic transducer.
- Quick clamp speed nut reduces wheel mounting time.
- Captured back spring eliminates having to handle the backing spring.
- Quick cycle time of 6 to 8 seconds
- Automatic recalculation if weight positions are changed. No need for re-spinning the wheel.
- Common 40 mm diameter mounting shaft.
- Weight pocket storage tray.
- Easy-to-Read Data display.
- Easy weight tray access.

#### SOFTWARE VERSATILITY

- Both dual weight Dynamic and single weight Static capability.
- Match Balance program for reducing weight required.
- Built-in spin counter for monitoring balancer productivity.
- Service code access to all Balancer electronic functions for fast, easy diagnosis.
- Operator selectable round-off mode.
- 5 Aluminum Modes
- 2 Alu-S modes
- Hidden Weight (Spoke) mode
- Ounce / Gram toggle from front panel
- Multiple operator feature allows several operators to recall wheel parameters.

## 1.5 STANDARD ACCESSORIES

Standard accessories ( Figures 1, 2, and 3,) included with the EEWB332A are:

- |    |             |                             |
|----|-------------|-----------------------------|
| 1  | EAM0003J69A | Cone, 87-137 mm / 3.4"-5.4" |
| 2  | EAM0005D25A | Cone, 96-114 mm / 3.8"-4.5" |
| 3  | EAM0005D24A | Cone, 71-99mm /2.8"-3.9"    |
| 4  | EAM0005D23A | Cone, 40-76mm / 1.6" -3.0"  |
| 5  | EAC0058D07A | Cup -Pressure               |
| 6  | EAC0058D08A | Disk -Pressure              |
| 7  | EAA0263G66A | Quick Nut                   |
| 8  | EAM0005D40A | Weight -Calibration         |
| 9  | EAM0021D90A | Standard 40mm Stub Shaft    |
| 10 | EAA0247G21A | Caliper -Rim Width          |
| 11 | EAC0060G02A | Flange -Cover, Hook         |
| 12 | EAM0006G01A | Pin -Accessory              |
| 13 | WWPR13A     | Weight Pliers               |
| 14 | EAM0005D34A | Fastening Rod               |
| 15 | EAC0058D15A | Soft Protector Ring         |

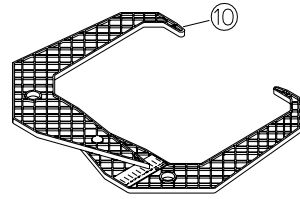

Figure 2 - Rim width gauge

### Weight Pliers (Figure 3).

Versatile weight hammer/plier. In addition to hammering on weight and used weight removal, the hammer/plier can be used to reshape worn weight clips and trim weight to size.

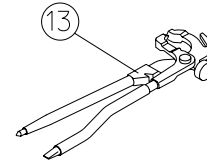

Figure 3 - Plier

## 1.6 OPTIONAL ACCESSORIES

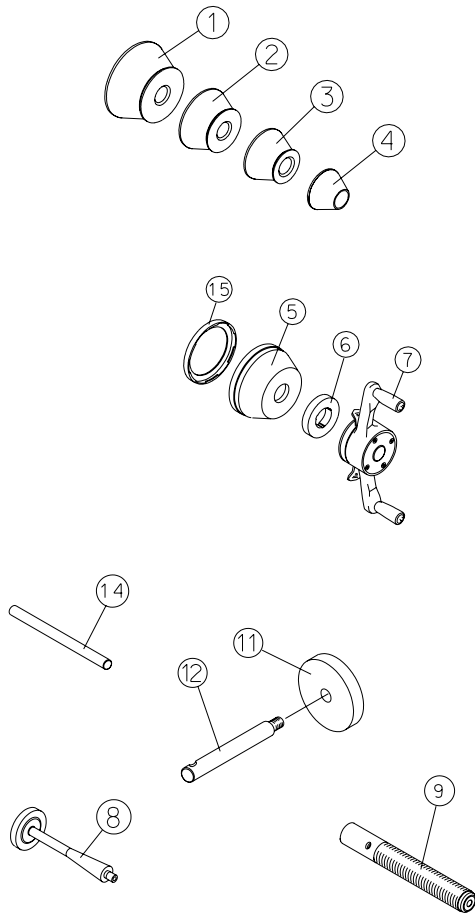

Figure 1



EEWB3-1A Car, SUV and Lt Truck Pin Plate Set  
EEWB3-4 9-pc Collet Set  
EAK0309J20A Stand



EEWB3-5 Spacer

EEWB3-75  
Truck Step Cone Kit



EEWB3-6 Motorhome and truck Pin Plate Set



## PRE-INSTALLATION CONSIDERATIONS

### 1.7 DIMENSIONS OF THE MACHINE



Figure 4 - Actual Footprint Dimensions.

### 1.8 REQUIRED INSTALLATION AREA

Make sure that from the operating position the user can see all of the machine and the surrounding area.

The operator should prevent non authorized persons and/or objects from entering the area which may create potential hazards.

The machine should be installed on a stable level floor. Do not install the machine on a uneven floor.

If the balancer is to be installed on a raised floor, the floor must have a capacity of at least 110lbs per sq ft. (5000 N/m<sup>2</sup> - 500 kg/m<sup>2</sup>).

It is not required to secure the machine to the floor.

Install the machine in a dry, covered area.

The installation of the machine requires a working area of at least 100" x 67" (2540mm x 1702 mm) (Figure 5).

**NOTE:** Do not install the balancer below grade level or in a pit.

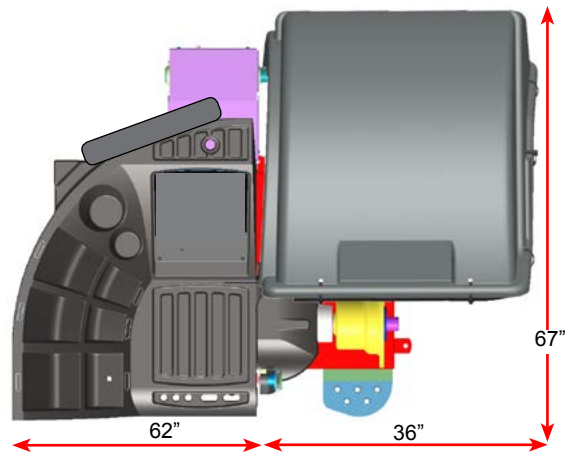

Figure 5 - Recommended Work Area

### 1.9 INSTALLATION INSTRUCTIONS

#### **CAUTION! CAREFULLY REMOVE THE BALANCER FROM THE PALLET.**

Remove the hardware that secures the machine to the pallet and slide the balancer onto the floor where it is to be installed.

#### **THE UNIT IS HEAVY AND THE WEIGHT IS NOT EVENLY DISTRIBUTED.**

#### **DO NOT LIFT THE BALANCER BY THE SHAFT.**

#### **DROPPING THE UNIT MAY CAUSE PERSONAL INJURY OR EQUIPMENT DAMAGE.**

### 2.0 BALANCER INSTALLATION

#### Mounting the Shaft Adapter

#### **IMPORTANT! CHECK THAT THE SURFACES ARE PERFECTLY CLEAN AND NOT DAMAGED. AN INCORRECT MOUNTING MAY RESULT IN SIGNIFICANT IMBALANCE.**

**A.** Mount the threaded shaft onto the arbor of the balancer. Tighten firmly using supplied rod. (Figure 6).

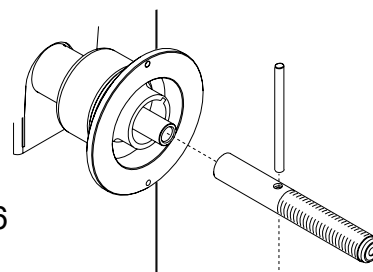

Figure 6

B. Install the accessory pins (Figure 7). Tighten firmly.

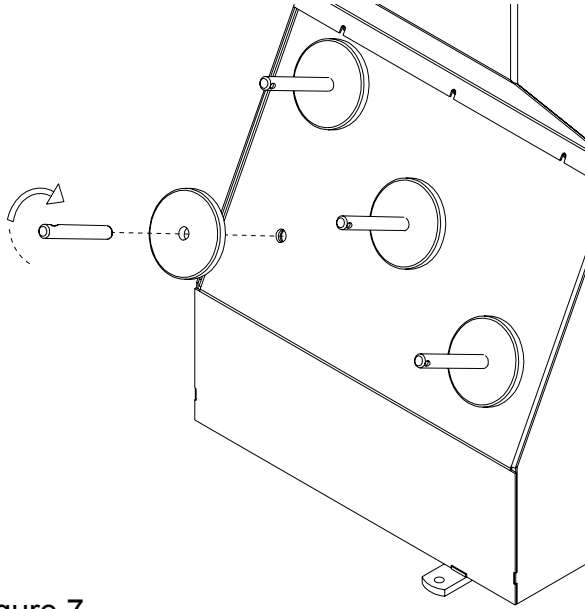

Figure 7

C. Place cones and other accessories onto the accessory pins.

## 2.2 ELECTRIC INSTALLATION

**ANY ELECTRICAL WIRING MUST BE PERFORMED BY LICENSED PERSONNEL.**

**ALL SERVICE MUST BE PERFORMED BY AN AUTHORIZED SERVICE TECHNICIAN.**

Check on the plate of the machine that the electrical specifications of the power source are the same as the machine. The machine uses 115VAC, 60Hz, 1Ph, 6.0 Ampere.

**NOTE:**

**Any electrical outlet installation must be verified by a licensed electrician before connecting the balancer.**

**NOTE:**

**This machine performs a self-test routine on start-up. There will be a delay of several seconds before the display is activated.**

## 2.3 MONITOR FRAME INSTALLATION INSTRUCTIONS

The monitor tower for the EEWB332A is shipped inverted so to facilitate shipping ease and to avoid damage. Follow these instructions for the proper installation procedures.

**MONITOR TOWER INSTALLATION:**

The Monitor Tower is shipped un-assembled to avoid damage.

1. Remove 3 bolts (2 holding monitor tower) See Figure 8.



Figure 8

2. Rotate tower 180° clockwise and reinstall the 3 bolts, see Figure 9.



Figure 9

## 2.4 INSTALLATION OF THE HOOD GUARD

1. Slide the wheel guard onto the pivot tube and raise it until the fastening holes of wheel guard and wheel guard arbor align. See Figure 10
2. Insert two 3/8" bolts with washers into the holes, install the hexagon nuts and washers and tighten.



Figure 10

3. Connect the plug of the cable with the connector of the machine which is projecting out of the opening in the balancer cabinet. See Figure 11.



Figure 11

4. Place the harness loosely inside the machine through the hole in the machine cabinet. See Figure 12

**!!!IMPORTANT!!!**  
**Machines are shipped calibrated from the factory. Do not attempt field calibration unless balance results deem calibration as necessary.**



Figure 12

### 3.0 TERMINOLOGY

Before using the wheel balancer it is suggested that you become familiar with the terminology and features of the machine's components. Refer to Figures 13 and 14 for identification and location.

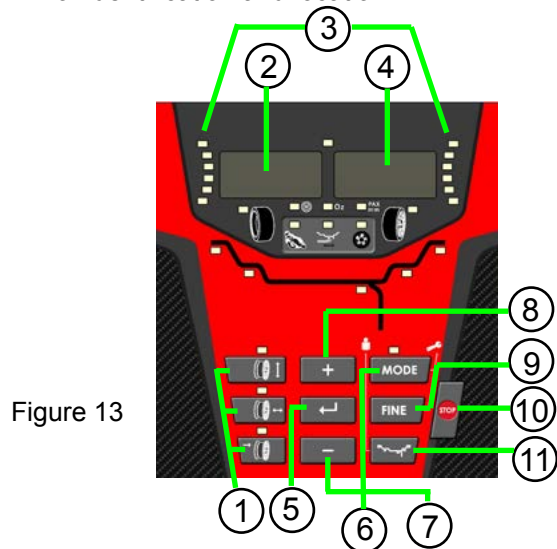

Figure 13

#### DISPLAY - Figure 9

1. Parameters:
  - Rim Offset - Key is used to enter the rim offset position using numbers from the distance gauge.
  - Rim Diameter - Enter the rim diameter. Read the size stated on the tire sidewall.
  - Rim Width - Press this key to enter the rim width. Use the rim width calipers for measurement.
2. Inside Weight Amount and Function Display Window Shows inside or left weight amount and various operation messages.
3. Position Indicator LEDs - Displays the location for wheel weight placement.
4. Outside Weight Amount and Function Display Window Shows outside or right weight amount and various operation messages.
5. Enter Key – Stores the data.
6. Mode key – Allows the operator to enter the special functions mode. Mode indicators are shown in the grey box below the weight amount display. (Motorcycle /Precision Tape Weight/ Optimization)
7. Minus Key – Reduces the displayed number. Press the enter key to store.
8. Plus Key – Increases the displayed number. Press the enter key to store.
9. Fine mode – Displays the weight amounts in 1 gram increments or ounces in tenths of an ounce.
10. STOP Key – Interrupts the balance cycle. Stops the wheel. Allows operator to cancel Split Mode.
11. ALu Modes - Selects each ALu mode.

#### CABINET - Figure 10



Figure 14

12. Display - Easy to read, user friendly display featuring large LEDs and one button functions.
13. Weight Storage Tray - Generous storage for a variety of weight profiles and sizes as well as built in storage pockets for the standard centering cones.
14. Accessory Storage - Four sturdy side mounted pegs are supplied for storage of additional accessories.
15. Wheel Guard Assembly.
16. Semi-Automatic Parameter Arm - Rim distance and diameter is automatically input with the SAPE. The SAPE is also used in several procedures for determining accurate rim profiles and tape weight placement.
17. Foot Operated Shaft Lock -A foot operated shaft lock is used to stabilize the shaft during the weight placement process.
18. Shaft Adapter - A common 40 mm size shaft is used. The easily removable shaft can be replaced for service or during use of certain wheel adapters
19. Sonic Transducer - Used for detection of the rim width.



## 4.0 OPERATION OF THE BALANCER

**WARNING:** For operator safety please read and follow the precautions outlined on pages 1 and 2 of this manual.

**NOTE:** Read all instructions before proceeding with operation of the balancer.

All balancer functions are input into the main computer through the large easy to read touch panel. Although each wheel tire assembly differ in some ways all balancing jobs require basically the same procedure. The order of events to take place are:

1. Inspection of the wheel/tire assembly
2. Mounting wheel onto shaft or adapter
3. Selection of Balancing Mode and Preferences
4. Entry of wheel parameters
5. Spinning the wheel
6. Applying the recommended weight
7. Check spin if desired
8. Dismounting the wheel

The following operation instructions will follow the basic outline above.

### 4.1 CHECK LIST - INSPECTION Observe Before Balancing Wheel

1. Check for proper air pressure. If not correct, inflate to correct pressure.
2. Check for any foreign material inside tire. If present, remove before balancing tire.

#### **WATER IS FOREIGN MATERIAL!**

3. Remove old weights — old weights may be improper value or in wrong location.
4. Be sure tire and wheel are free of excessive dirt, rust and large stones. Use wire brush on back side of wheel if necessary.

## 4.2 WHEEL MOUNTING

Nearly all standard wheels and many alloy wheels have accurately machined center holes, and they should be mounted with center cones. Accurate balancing depends on accurate mounting of the wheel and correct seating of the cone in the pilot hole. Insure that the wheel is centered on the shaft exactly as it will be mounted to the vehicle.

Before starting any balancing procedure it is very important that the wheel is mounted on the machine with the proper adaptors. An incorrect centering of the wheel will result in considerable imbalance.

There are many types of wheels and Snap-on supplies adaptors of good quality and durability for the large majority. However if you meet special wheels which may require a specific adaptor, call your Snap-on distributor.

Rims may be divided into these major groups:

1. **Car rims with a true center hole.**
2. **Car rims without a center hole.**
3. **Car rims with an untrue center hole.**
4. **Light truck rims.**
5. **Lug centric wheels**
6. **Clad wheels**

### 4.2.1 Standard Wheels (back cone mount)

Mount the wheel as detailed below in Figure 15

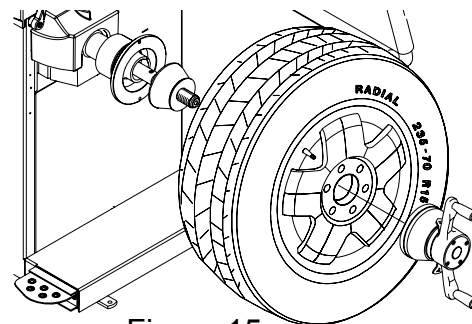

Figure 15

1. Mount proper cone against spring plate.
2. Mount wheel on shaft in the same manner as you would on the car.
3. Mount pressure cup on shaft and place against outside of wheel, follow with the Quick-nut.
4. Tighten Quick-nut securely with both hands. To operate the Quick-nut pull the lock-unlock lever (Figure 16). Slide the Quick-nut on the threaded shaft. When in contact with the rim, release the unlock lever and tighten firmly. To assist in centering the wheel properly, rotate the wheel on the shaft while tightening the quick nut.



Figure 16

**⚠ WARNING!**  
**FAILURE TO TIGHTEN WING NUT SECURELY  
 MAY RESULT IN SERIOUS PERSONAL INJURY.**

**DO NOT USE A HAMMER TO TIGHTEN THE  
 QUICK NUT.**

**TO RELEASE THE QUICK NUT, UNSCREW A  
 FEW TURNS TO REDUCE THE AXIAL PRES-  
 SURE, THEN PRESS THE UNLOCK LEVER AND  
 SLIDE AWAY FROM THE SHAFT.**

5. Check that the wheel rotates true by turning the wheel several revolutions while noting any excessive runout.

#### 4.2.2 CENTERING LIGHT-TRUCK WHEELS

An optional offset spacer may be required for some light truck wheels and reverse-offset wheels that must be moved away from the balancer mounting flange. The extension adaptor is often used with the 5-1/4 inch diameter light truck cone. (p/n EEWB-5)

Install the spacer on the mounting flange, then mount the wheel, using the front cone method (Figure 17)

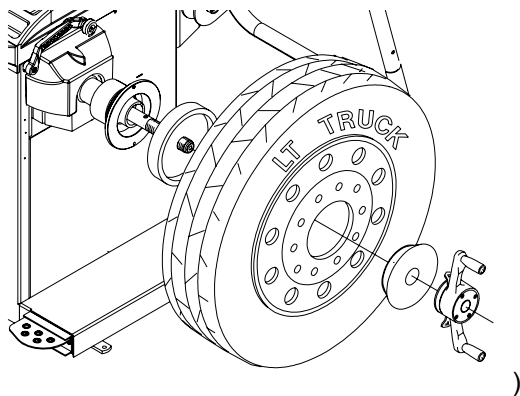

Figure 17

#### 4.2.3 WHEEL MOUNTING REQUIRING SPECIAL TOOLING

Clad wheels: A Clad Wheel is a wheel casting that is balanced but the wheel face is not finished. To finish the wheel face a plastic chromed face is bonded to the casting.



A clad wheel must be centered properly from the back side of the wheel using precision collets instead of a centering cone. A precision collet is normally a dual sided centering device with low tapers on each side and has a length of approximately 1.5 inches. The benefit of a precision collet is it fits very precisely into the tapered machining on the back side of a cast wheel and the collet does not protrude into the wheel center. A cone also offers precision centering, but a cone can have a length from the long to short end of the taper of two inches or more. A taper cone unlike a precision collet, will intrude into the wheel center. On many clad wheels there are plastic tabs to hold the cosmetic cover in place. It is also necessary to use a pin plate in the front of the wheel. The standard pressure cup may crack the plastic cladding. A centering cone can break off the tabs. See section 1.6 Optional Accessories for tooling recommendations.

### 4.3 MODE SELECTION

The majority of balancing takes place in the default 2-plane dynamic mode which is displayed as “2 PL” (location 1). Hammer-on clip weights will be placed on both inside and outside of the rim edge. If required, select an optional weight placement mode by pressing the *Mode* button until the appropriate placement mode is displayed.

#### 4.3.1 WEIGHT PLACEMENT MODES

Before Spinning the wheel (although it may be done afterwards) choose the appropriate balancing mode for the wheel. To select the various placement modes press the (9) **Weight Placement** button until placement LEDs indicate desired placement position.

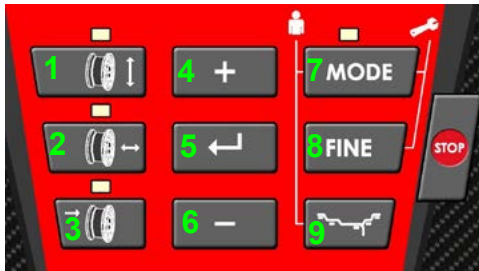

Figure 18

**A. DYNAMIC** (two planes), suggested for all steel rims. In this case the wheel weights must be clipped onto the rim edges. This function is selected as a default and the LEDs corresponding to the wheel weight location are lit on (Figure 19)

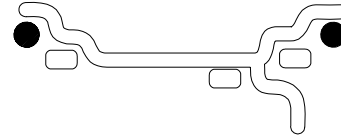

Figure 19

**B. STATIC** (single plane - Figure 20). Suggested for narrow rims (3” or less). Use a single corrective weight placed in the center of rim as illustrated in Figure 20.

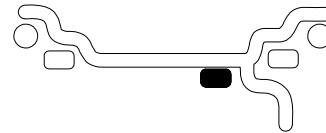

Figure 20

#### WEIGHT COMBINATION MODES USING THE WEIGHT SELECTION BUTTON

See (Figure 21). Pressing the weight selection button (9) will toggle the LED's to the weight default selections as shown. Balancing using a combination of hammer-on and adhesive weights as shown in Figure 21.

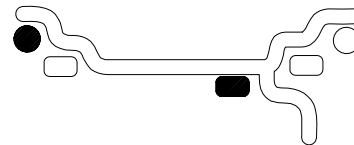



Figure 21



### 4.3.2 SELECTING THE ALU TYPES

Images shows the corrected weight application positions for adhesive weights and clip-on weights.



Select the Weight Placement button  to recall the required ALU P weight positions.

Normal weight and clip - on weight positions on the rim flange.



Alu 1

Alu 1 Adhesive weights applied symmetrically to the rim flanges with NOMINAL weight positioning.

Alu 1P Adhesive weights applied symmetrically to the rim flanges; the compensation planes for the adhesive weights are read precisely using the gauge arm.



Alu 2

Alu 2 Adhesive weights - Adhesive weight on rim flange, adhesive weight hidden in rim disc with NOMINAL positioning.

Alu 2P Adhesive weights - Adhesive weight on rim flange, adhesive weight hidden in rim disc; the compensation planes for the adhesive weights are read precisely using the gauge arm.



Alu 3

Alu 3 Clip - on weight on left rim flange, adhesive weight hidden in rim disc. Weight positioning is NOMINAL.

Alu 3P Clip - on weight on left rim flange, adhesive weight hidden in rim disc; the compensation planes for the adhesive weight is read precisely using the gauge arm.



Alu 4

Alu 4 Balance clip fitted on left rim flange, adhesive weight attached to right bead seat.

## 4.4 SELECTING OPERATOR PREFERENCES

### 4.4.1 FINE BALANCING MODE

This balancer measures with the maximum precision available all the time, 1g / 0.05 oz, however values below 5g / 0.25 oz are shown as zero while in the normal operating mode. Values exceeding 5g / 0.25 oz are rounded to the amount of the nearest commercial wheel weight.

Press the **FINE** button to advance to the display resolution between 5g / 0.25 oz and 1g / 0.05 oz.

### 4.4.2 OUNCE/GRAMS CONVERSION

When the machine is first turned on it is preset to display the imbalance in ounces.

Press the **MODE** button to advance to select ounces or grams.

Select Enter to save selection.

### 4.4.3 RIM DIAMETER IN MILLIMETERS

The rim diameter is normally displayed in inches, however if the value in millimeters is desired. Press the **MODE** button until "PAX/mm" is NOT illuminated to display in inches, when lit the unit displays in mm.

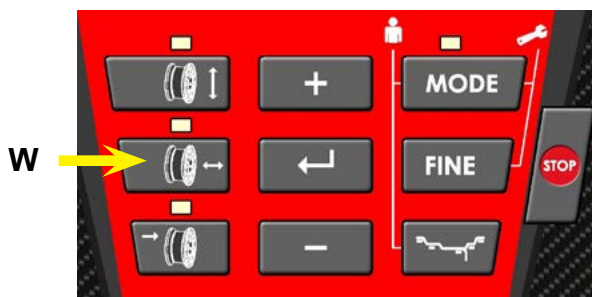

Figure 23a

## 4.5 ENTER RIM PARAMETERS

**4.5.1 Rim Distance and Diameter (offset)** - Move the rim offset arm to the edge of the rim, touch the pointer to the rim edge as illustrated in Figure 22 and hold steady for about a second. The beeper will sound when the distance and diameter values are calculated and entered. Return the arm to its fully in and down position on the balancer. Do not allow the measurement arm to "dangle" down in front of the balance.

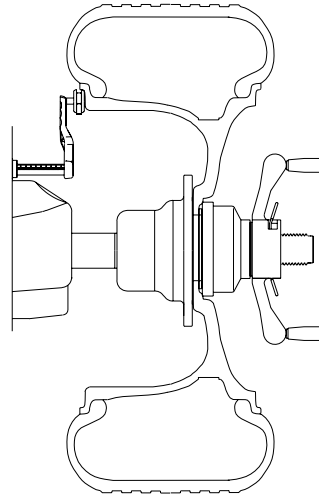

Figure 22

**4.5.2 - Rim Width Measurement** - Lower the hood guard. The rim width will be automatically enter using the sonar sonic device mounted on the hood guard frame.

**4.5.3. Measure/Enter rim width (manual)** using rim width calipers. Measure wheel where corrective clip-on weight would be applied, Figure 23b. Press the Width entry key, Figure 23a, and enter the measured width by pressing +/- keys until the desired value appears in the display.

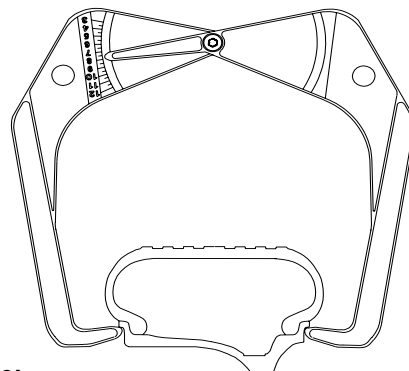

Figure 23b

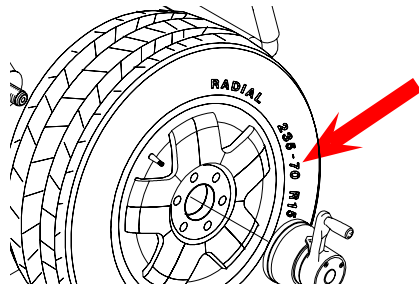

Figure 24a

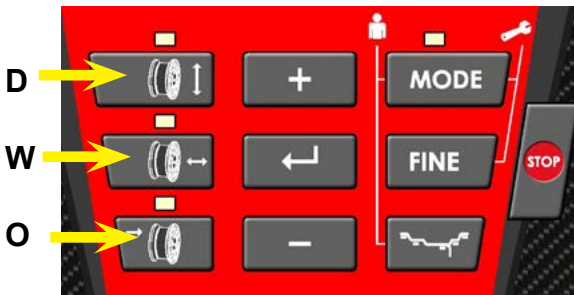

Figure 24b

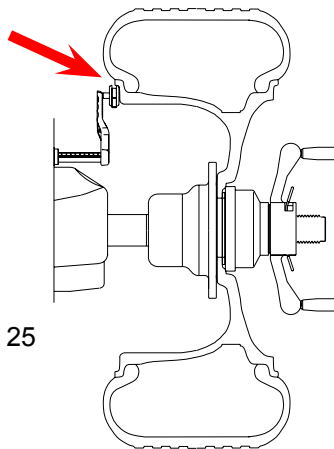

Figure 25

#### 4.5.4 Manual Parameter Entry

In the event of automatic gauge failure, the parameter values can be input manually. See manual entry of rim width in the previous paragraph.

**4.5.4.1 Manual Rim Diameter Entry** - Select the Manual Diameter button. Read the rim diameter marked on the sidewall of the tire (Figure 24a and 24b). Press the Diameter Button (D) and enter the measured rim diameter by selecting the +/- keys until the desired value appears in the display.

**4.5.4.2 Manual Distance Entry** - Move the distance gauge arm to touch the inner edge of the wheel where weights are to be placed and observe the reading on the scale of the distance gauge. See Figure 25. Press manual Wheel **Offset** button (O) followed by selecting the +/- keys until value is displayed in the display window.

**NOTE:** The parameter arm must be in the Home rest position when the balancer is powered up. This establishes the arm starting position.

## 4.6 CORRECTION OF THE IMBALANCE

The following weight types and application methods are available:

- Clip-on weights: Always apply by hand
- Stick-on weights: Can be applied by hand or using the gauge head for the Alu 2P, Alu 3P or easy weight mode.

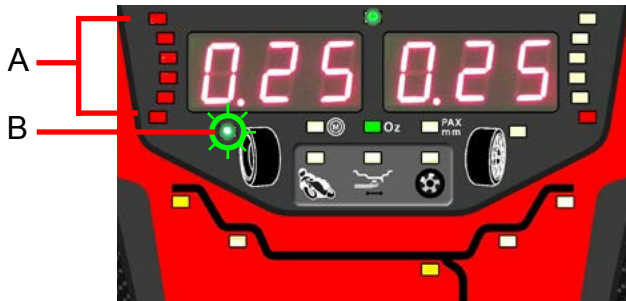

Figure 26

Hand applied weights **MUST** be applied exactly perpendicular to the shaft (12 o'clock position). After Spinning the wheel look at the rotation indicators for the left plane of the wheel, Figure 26-A. As the correct Wheel Angle Position (WAP) gets closer more indicators light up. When all the indicators are ON, the WAP indicator will also light up, Figure 26-B. Follow same procedure for placing weight in the right plane.

**Note:** When the correct angle is reached, all the rotation indicators should be ON. If the wheel has been pushed too far, only the indicators of the other half will come ON. If this happens, the wheel must be slowly turned in the opposite direction until the WAP position is reached. The weight amount to be applied in that plane is shown on the display.



Figure 27a

### Attaching a clip-on weight.

Refer to Figure 27a. Clip-on weights must always be applied in the 12 o'clock position. The lip should rest on the rim edge. Use the weight pliers to position it. In STATIC mode only the left hand display is used.



Figure 27b

### Attaching a stick-on weight.

ALU or STATIC weight modes only: Refer to Figure 27b. Apply the weight on the rim in the 12 o'clock position, always by hand.

**Note:** With STATIC weight modes, always apply the weight at the rim center line. If not possible, split the weights evenly and apply on another surface of the rim (symmetrical to the rim center line).

### 5.0 Alu 2P and Alu 3P (page 17) weight modes

To activate Alu 2P or Alu 3P Continue pressing the Placement button  until the Easy Alu LED is lit. See Figure 28b-C.



Figure 28a

When Alu 2P or Alu 3P is selected, The gauge arm is used to determine the desired weight location, Extend the gauge to the inner position and wait a few seconds for the placement to register, the placement LED will flash during this time. See figure 28b-D. Extend the gauge arm to the outer position and wait for the signal to return the arm to home. Lower the hood to spin the assembly.

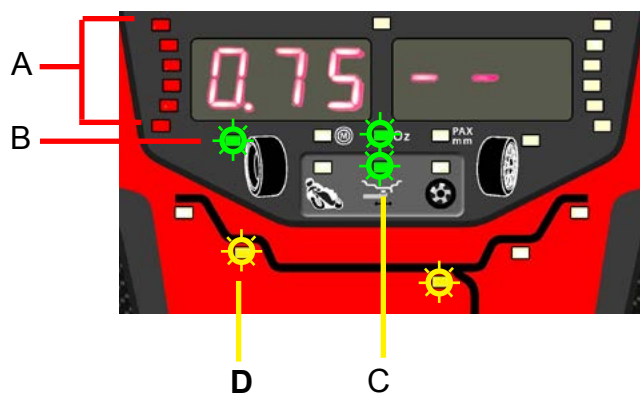

Figure 28b

Use the gauge arm to position the corrective weights as indicated by the display. Rotate the wheel until all position LEDs are lit (Figure 28b-A). If correcting the left plane, the right amount window will display a series of dashes while searching for the placement location.

While moving the arm, a beep indicates when the correct application position has been reached. The weight amount will then be displayed and flash and the WAP indicator will lite up (Figure 28b-B). Press the foot pedal to hold the wheel in this position. Apply the weight to the correct point on the rim.

**NOTE:** Clean the area where the weight will be placed before attaching the adhesive weights. Insert an adhesive weight at the center of the gauge arm in the amount displayed and remove the protective tape from the adhesive strip.

**Split Weight Mode** or sometimes called **Spoke Mode** can be invoked if desired. See chapter 6.0.

**NOTE:** Either left or right plane can be corrected first.

Rotate the wheel to the next position, put the stick-on weight on the gauge arm and apply the weight for the remaining position. After applying the balance weights perform a Check Spin.

It is good practice to perform a check spin after applying the weights. Spin the wheel. Having finished the Run, if the wheel is balanced correctly, both the numerical indicators should indicate 000. To check how much imbalance is left: Select the FINE key. The operator should decide if applying additional weight is required.

Results recalculation. After Spinning a wheel it is possible to enter new rim data or select another weight mode. The results are recalculated automatically. Selecting another weight mode such as between NORMAL, ALU and STATIC no additional steps required either.



## 6.0 SPOKE BALANCING MODE

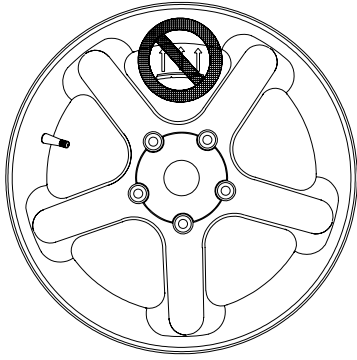

Figure 29a

When spoke wheels are balanced, the behind-the-spokes placement mode (also called split weight mode) allows balance weights which would have to be fitted between two spokes according to the measured unbalance (hence would be visible from outside) to be placed in hidden position behind two spokes adjacent to the unbalance location. After a measuring run the electronic unit calculates the behind-the-spokes placement automatically and reads the relative balance weight locations on the screen. The operating steps for the behind-the-spokes placement mode are described and illustrated below figure 29b

### 6.1 SPLIT WEIGHT MODE (SWM)



Figure 29b

1. Select desired placement mode, ALU-2 or 3 will both function with spoke mode. Must be behind the wheel weight position to select.
2. Measure position one and two with the gauge arm.
3. Lower the hood to perform a balance run.
4. Place inner corrective weights. Hold wheel assembly secure with the foot brake when placing weights.

*HINT: With the hood guard open press the "Plus" key to quick spin the tire to the next weight correction position.*

5. Once you have a weight amount displayed. Rotate the outer plane to the weight position indicated when all LEDs are illuminated.
6. Press the Mode key. Then press Enter.
7. The Spoke icon should illuminate as well as the Mode LED.
8. Rotate the wheel to the first spoke or closest spoke position with P1 on the display. Press the enter key for position one. Figure 29c
9. Rotate the wheel to the second or next closest spoke position with P2 on the display and press enter. Figure 29d
10. The weight amount for correction is now divided by two and displayed between the two spokes selected.
11. Place the outer corrective weights using the SAPE arm

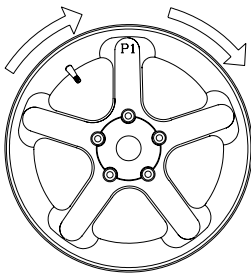

Figure 29c

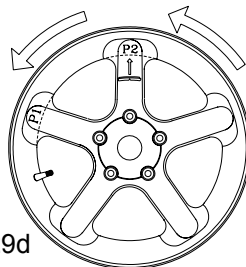

Figure 29d

## 7.0 USER CALIBRATION

Figure 30a



Figure 30b



Figure 30c



Figure 30d

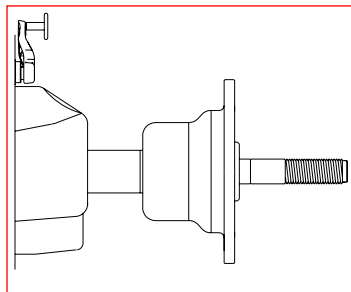

Figure 30e



Figure 30f

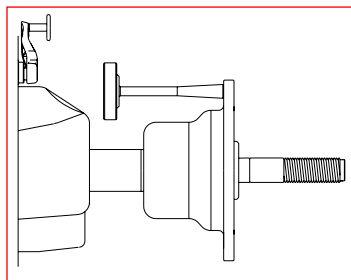

Figure 30g



The EEWB332A Balancer features a calibration verification program which requires only a few minutes to complete. Perform this procedure to verify calibration when the balancer has been moved, disturbed, or whenever accuracy is questioned. If the calibration process fails a service technician should be dispatched to perform a complete calibration.

A calibration run takes no longer than a regular balance run.

Press the “MODE” key and the “FINE” key together for 5-7 seconds. See Figure 30a. The initial display reads “C 14”, See Figure 30b.

Press ENTER once to initiate procedure. The display shows “CAL 1” and the unit beeps. See Figure 30c.

Remove any cones or adapters from the shaft. See Figure 30d. Lower the hood to spin the shaft. (Press ENTER if unit does not spin automatically.)

When complete, the display shows “CAL 2”. Mount the User Calibration Weight, refer to Figure 30f. Lower the hood and spin the shaft.

The wheel will be braked.

After a few seconds the display equals C ---, Figure 30g. The User Calibration was performed correctly.

Any (operator) error causes the program to exit. Unscrew the Calibration weight from the flange and put it back in its designated place for safe keeping.

## 8.0 USER FUNCTIONS

### 8.10 Data Recall

Use this function to store or recall rim data (wheel type, diameter, width, Offset, fine mode, oz. mode and mm mode) in or from the memory. 4 sets of wheel data (the so-called user data) can be stored.

When it is turned ON the balancer sets the wheel data regarding user A to the system default values and sets the current user to user A.

Figure 31a



To activate:

- Press the “MODE” and the “Weight Placement” keys simultaneously for 3 seconds. See Figure 31a.
- The function starts with the SAVE option.
- The data can be saved to the user displayed on the right.

To clear the data (without saving):

- Select Enter when user “- -” is displayed.

To save data:

- Select + or – to scroll along User A, b, C or d.
- Select Enter to save to the selected user.

The function proceeds with the RECALL option.

The data can be recalled from memory by selecting the appropriate user. The selected user will be the new current user, such as User b.

No recall required (no change in user required):

- Select Enter when user “- -” is displayed.

To recall data:

- Select + or – to scroll along User A, b, C or d.
- Select Enter to recall the selected user.
- The current available wheel data will be replaced by the recalled data such as: “b”.

### 8.20 Anti-slip function

On wheels with a limited weight, slip specifications may make it impossible to perform a balance run at the normal measuring speed.

This feature is intended to alert when wheels are not well clamped on the shaft. There may be a false error with very light wheels or bare rims.

This function may be disabled for a single balance run: Hold the Enter key down while the wheel guard is lowering.





Figure 31b

### 8.30 WEIGHT UNIT TOGGLE MODE

Setting the basic weight unit: oz/grams

Select this mode to change the unit of measure of the weight before or after carrying out a balancing operation.

- Press the “MODE” key until the weight units indicator flashes. The “oz” indicator will start flashing.
- The display will now look like Figure 31b.
- Press Return.

The weight setting status now calculates weights using a different unit of measure (from grams to ounces or from ounces to grams).

The program returns to the main menu.



Figure 31c

### 8.40 DIMENSION UNIT TOGGLE MODE

Setting the basic unit of measure for diameter and width: inches/mm

Select this mode to change the unit of measure of the diameter and width before or after carrying out a balancing operation.

- Press the “MODE” key until the dimensional units indicator blinks.

The “mm” indicator will start flashing.

The display should now appear as shown in Figure 31c.

Note: The operator can now select the units in steps of 1 mm if the mm mode has been selected.

- Select return.

The state of the diameter and width dimension units will toggle (inch to mm, or mm to inch).

Note: The unit is set to default to inches.

Offset is always measured and shown in millimeters.

The program returns to the main menu.



5-32



5-33

## 9.0 OPTIMIZATION/WEIGHT MINIMIZATION.

### Balancing optimization program cycle

The following is a description of the balancing optimization program cycle (code OP) and weight minimization (code UN).

#### Balancing optimization

##### Figure 5-32

If after the measuring run the imbalance in the left or right correction plane and/or the static imbalance is more than 30 grams, perform automatic optimization by activating the **FINE+ENTER** key (3+1).

- Before optimization check that the rim dimensions have been set correctly.

You cannot correct the data later.

- Demount the tire and clamp only the rim for the compensation run.

- Press the **ENTER** key (1).

The **OP.1** reading appears (Fig. 5-33).

In all figures in which the valve symbol appears on the edge of the rim, shift the tire on the rim then press the **ENTER** key (1) to set the valve position (exactly perpendicular to and above the main shaft).

- Readjust the rim so that the valve is exactly perpendicular to and above the main shaft.
- Press the **ENTER** key (1) to acquire the valve position.

The **OP.2** reading appears.

An incorrect valve position entry can be corrected afterwards.

#### Weight minimization

If no optimization, but only weight minimization (i.e. without compensation run for the rim without tire), proceed as follows:

- Clamp the complete wheel (rim and tire).
- Press **FINE** (3) + **ENTER** key (1) if minimization is started separately from optimization.

The **OP.1** reading appears.

- Press the **FINE** key (3) to activate the weight minimization program.

The **Un.3** reading appears;

Run the minimization program.

- With program **OP.2** the rim compensation run can still be omitted. Go to the next step in the program by pressing the **FINE** key (3).

The **UN.4** reading appears.

- Continue the minimization program.

The valve position entered with **OP.1** is automatically used.



5-32



5-34



5-35

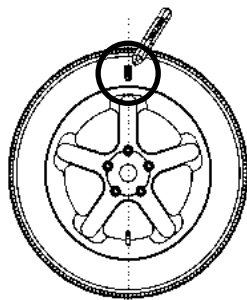

5-36

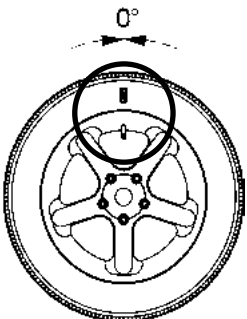

5-37

**Continuing balancing optimization**

(Fig. 5-34)

- START the rim compensation run, without the tire. After the measuring run the **OP.3** reading appears.
- Mount the tire and inflate correctly (see note below).

**Note**

For mounting and demounting (tire changer) and tire turning or readjustment on the rim, always apply a sufficient amount of tire lubricant on the tire beads and the rim edges and shoulders. Each time the position of the tire is changed on the rim, inflate the tire to overpressure (approx. 3.5 bar) then deflate to correct tire pressure.

Make sure the centering line is correctly positioned on the tire bead.

- Clamp the wheel.
- Position the valve exactly perpendicular to and above the main shaft.
- Press the **ENTER** key (1) to acquire the valve position.

**OP.4** appears (Fig. 5-34).

- Spin the wheel (START).

The measuring run is carried out. After the measuring run two readings are possible:

**OP.5 - H1**

Further optimization is not recommended, but possible.

**OP.5 - I** (1 Reference mark Fig. 5-35)

Continue with the OP program.

Reading **OP.5 - H1**

If **OP.5 - H1** appears, further optimization is not recommended, since the measurement values which activated the optimization recommendation are below the limit value. However, it is possible to continue optimization for the most silent possible wheel running, reducing imbalances below the limit value (critical vehicle).

To continue optimization

- To continue with the OP program proceed as specified for **OP.5 - I** (given below).

To abort optimization

- Press the **STOP** key to return to the balancing program and balance the wheel according to the readings (5.9).

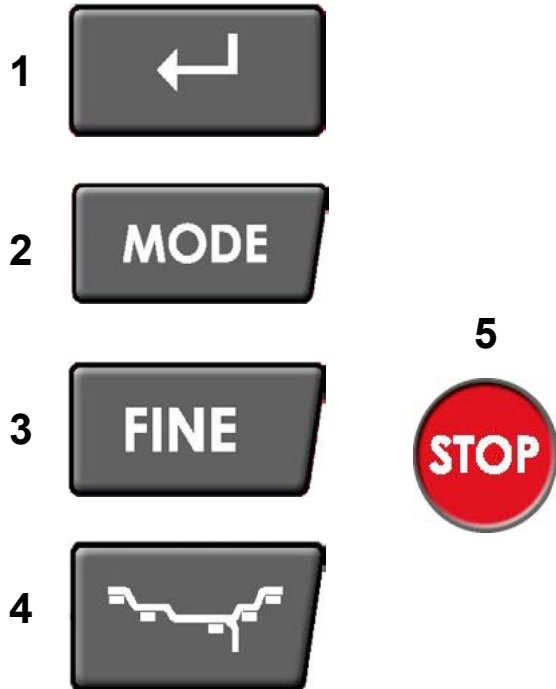

5-32



5-34



5-37

Reading **OP.5 – I** (1 Reference mark **Fig. 5-35**)

- After the measuring run readjust the wheel following the direction indicator and make a chalk mark on the right side of the tire exactly perpendicular to and above the main shaft.
- Readjust the tire on the rim so that the reference mark made is aligned with the valve (use tire changer).
- Clamp the wheel on the balancer and readjust it until the valve is exactly perpendicular to and above the main shaft.
- Press the **ENTER** key (1) to acquire the valve position.

The **OP.6** reading appears (**Fig. 5-34**).

- Spin the wheel (**START**).

After the measuring run four readings are possible:

**II - OP.7**

Proceed with the OP program. It is recommended that the tire be turned over on the rim.

**OP.7 - II**

Proceed with the OP program. It is recommended to shift the tire on the rim (manual rotation).

**H0**

Optimum condition has been achieved and cannot be improved.

**H2**

Silent running cannot be improved.

- Press **STOP** (5) to exit.

However, it is possible to readjust the tire relative to the rim to achieve significant weight minimization (i.e.: smaller balance weights) without having an adverse effect on silent running.

Depending on the readings, there are several possibilities for proceeding with the program. These possibilities are described below.

Reading **II - OP.7** (**Fig. 5-37**)

Turn the tire over on the rim (the left display bars are rotating).

**Option 1:** Turn the tire over on the rim (normal program).

- Readjust the wheel according to the left direction indicator and make a double mark on the left side of the tire exactly perpendicular to and above the main shaft.
- Remove the wheel from the machine.
- Turn the tire over on the rim and readjust until the double mark coincides with the valve.
- Clamp the wheel on the balancer and readjust it so that the valve is exactly perpendicular to and above the main shaft.
- Press the **ENTER** key (1) to acquire the valve position.

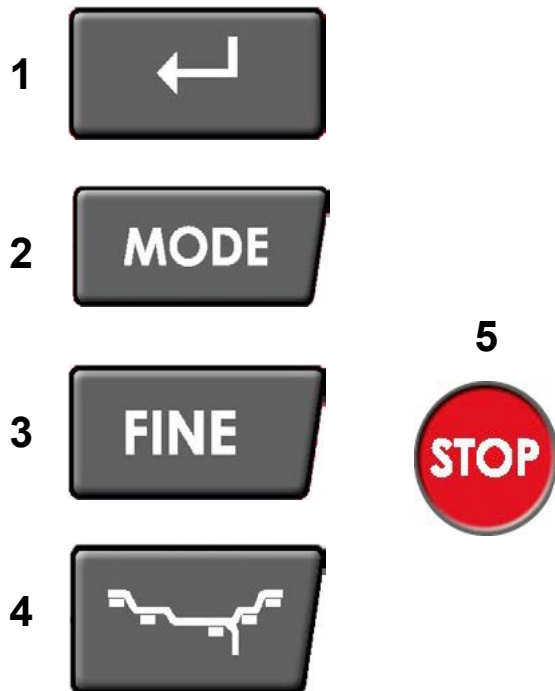

5-32



5-34



5-37

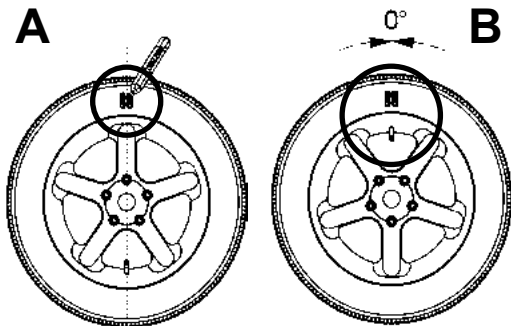

5-38

5-39

Reading **OP.8** appears (Fig. 5-34).

- Spin the wheel (START).

If balancing optimization (silent running) has been carried out correctly (according to the program cycle), after the check run the machine automatically returns to the type of weight positioning previously selected and indicates the residual dynamic imbalance on the wheel.

- Balance the wheel according to the readings. Both optimization and balancing are accomplished.

Message **E9**

Message E9 means that at least one error occurred during the optimization cycle. Press the **STOP** key (5) to exit the optimization program and repeat optimization if necessary.

**Option 2:** Do not turn the tire over on the rim

- Press the **FINE** key (3).

The result is recalculated.

Reading **OP.7 - II** or **H0** or **H2** appears

- To go to **II - OP.7** (turning over the tire) press the **FINE** key (3) again.

**Option 3:** Abort optimization

- Press the **STOP** key (5) to exit the OP program and return to the balancing program.

The imbalance on the wheel is shown on the readout.

- Balance the wheel according to the readings.

Reading **OP.7 - II** (Fig. 5-37)

Readjust the tire on the rim (the right display bars light up permanently).

**Option 1:** Readjust the tire on the rim

(normal program)

- Readjust the wheel following the right direction indicator and make a double mark on the right side of the tire exactly perpendicular to and above the main shaft (Fig. 5-38).
- Remove the wheel from the machine
- Readjust the tire on the rim until the double mark coincides with the valve (Fig. 5-39).
- Clamp the wheel on the balancer and readjust so that the valve is exactly perpendicular to and above the main shaft.
- Press the **ENTER** key (1) to acquire the valve position.

Reading **OP.8** appears (Fig. 5-34).

- Spin the wheel (START) (check run).

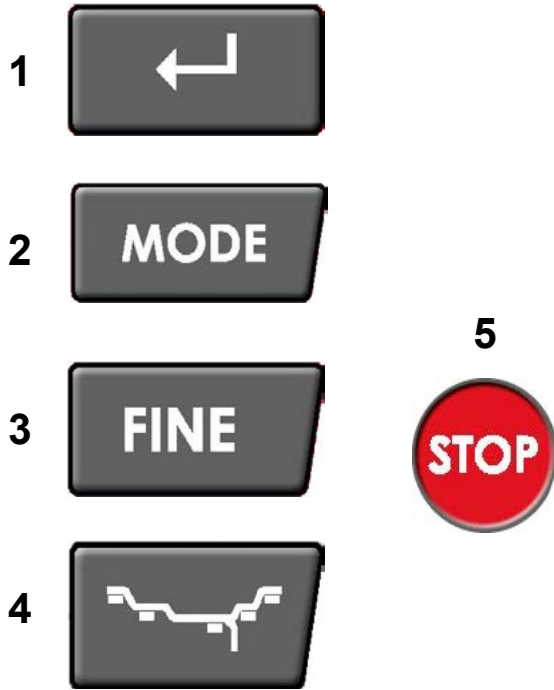

5-32



5-34



5-35

If balancing optimization (silent running) has been carried out correctly according to the program cycle, after the check run the machine automatically returns to the type of weight positioning previously selected and indicates the residual dynamic imbalance on the wheel.

- Balance the wheel according to the readings.

Both optimization and balancing are accomplished.

Message **E9**

Message E9 means that at least one error occurred during the optimization cycle. Press the **STOP** key (5) to exit the optimization program and repeat optimization if necessary.

**Option 2:** do not adjust the tire on the rim

- Press the **STOP** key (5) to exit the OP program and return to the balancing program.

The imbalance on the wheel is shown on the readout.

- Balance the wheel according to the readings.

Reading **H0**

- Press the **STOP** key (5) to exit the OP program and return to the balancing program.

The imbalance on the wheel is shown on the readout.

- Balance the wheel according to the readings.

The optimum balancing optimization condition has been achieved and cannot be improved.

Reading **H2**

Silent wheel running cannot be improved. However, it is possible to achieve weight minimization (readings with code **UN.**).

**Option 1:** Weight minimization

- Press the **FINE** key (3) to continue the program.

As a result reading is **II - Un.7** or **Un.7 - II**

**Option 2:** Abort optimization

- Press the **STOP** key (5) to exit the OP program and return to the balancing program.

The imbalance on the wheel is shown on the readout.

- Balance the wheel according to the readings.





5



5-32



5-35



5-34

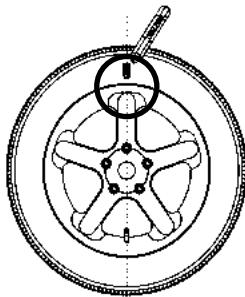

5-36

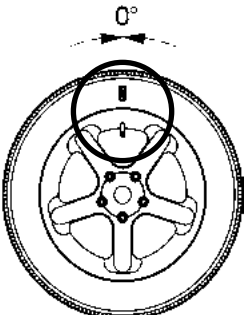

5-37

**Weight minimization program cycle**

If the rim compensation run was omitted and the **FINE** key (3) was pressed to go directly into the minimization program (reading **Un.**), proceed as follows.

- Clamp the wheel.
- Position the valve exactly perpendicular to and above the main shaft.
- Press the **ENTER** key (1) to acquire the valve position.

Reading **Un.4** appears (Fig. 5-34).

- Spin the wheel (START).

The measuring run is carried out. After the measuring run two readings are possible:

**Un.5 - H1**

Further minimization is not recommended, but is possible.

**Un.5 - I** (1 Reference mark Fig. 5-35)

Continue with the UN program.

**Reading Un.5 - H1**

If **Un.5 - H1** appears, further minimization is not recommended since the measurement values do not exceed the limit values. However, it is possible to continue minimization so as to achieve an improvement, if only slight (e.g.: for critical vehicles).

To continue minimization:

- Proceed as indicated for reading **Un.5 - I**.

To abort minimization:

- Press the **STOP** key (5) to return to the balancing program and balance the wheel according to the readings.

**Reading Un.5 - I** (1 Reference mark Fig. 5-35)

- After the measuring run readjust the wheel according to the direction indicator and make a chalk mark (Fig. 5-36) on the right side of the tire exactly perpendicular to and above the main shaft.

- Readjust the tire on the rim so that the mark coincides with the valve (use the tire changer Fig. 5-37).

- Clamp the wheel on the balancer and readjust it so that the valve is exactly perpendicular to and above the main shaft.

- Press the **ENTER** key (1) to acquire the valve position.

Reading **Un.6** appears (Fig. 5-34).

- Spin the wheel (START).

The machine performs the second measuring run with the tire. After the measuring run three readings are possible:

**II - Un.7**

Proceed with the UN program. It is recommended that the tire be turned over on the rim.

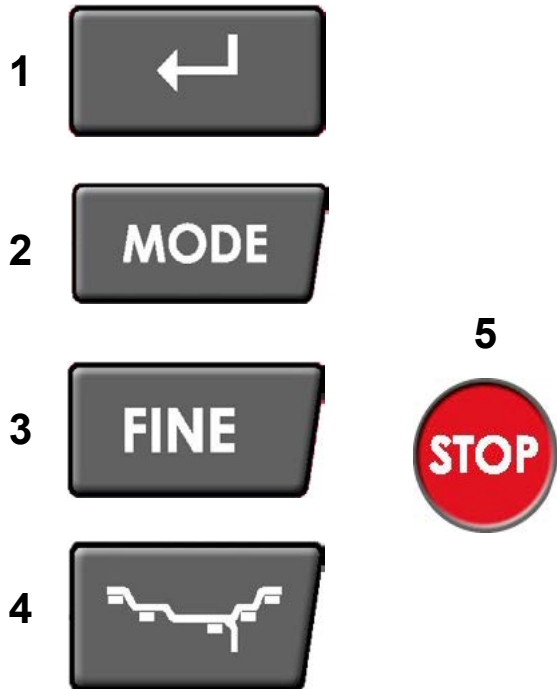

5-32



5-37



5-34

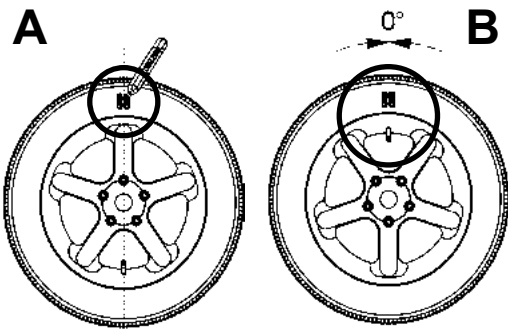

5-38

5-39

**Un.7 - II**

Proceed with the UN program. It is recommended that the tire be readjusted on the rim.

**H0**

The optimum minimization condition has been achieved and cannot be improved.

Depending on the readings, there are several possibilities for proceeding with the program. These possibilities are described below.

**Reading II - Un.7**

Turn the tire over on the rim (the left display bars are rotating).

**Option 1:** Turn the tire over on the rim (normal program)

- Readjust the wheel according to the left direction indicator and make a double mark on the left side of the tire exactly perpendicular to and above the main shaft (Fig. 5-36).
- Remove the wheel from the machine.
- Turn the tire over on the rim and readjust until the double mark coincides with the valve (Fig. 5-37).
- Clamp the wheel on the balancer and readjust it so that the valve is exactly perpendicular to and above the main shaft.
- Press the **ENTER** key (1) to acquire the valve position.

Reading **Un.8** appears (Fig. 5-34).

- Spin the wheel (START) (check run).

If weight minimization was carried out correctly (according to the program cycle), after the check run the machine automatically returns to the type of weight positioning previously selected and indicates the residual dynamic imbalance on the wheel.

- Balance the wheel according to the readings. Both weight minimization and balancing are accomplished.

**Message E9**

Message E9 means that at least one error occurred during the minimization cycle. Press the **STOP** key (5) to exit the minimization program and repeat minimization if necessary.

**Option 2:** Do not turn the tire over on the rim

- Press the **FINE** key (3).

The result is recalculated.

Reading **Un.7 - II** or **H0** appears

**Option 3:**

- Press the **STOP** key (5) to exit the minimization program and return to the balancing program. The imbalance on the wheel is shown on the readout.
- Balance the wheel according to the readings.



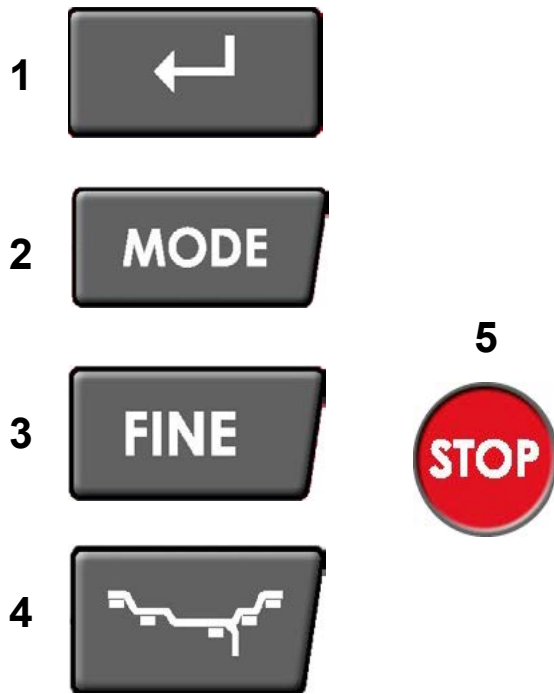

5-32

Reading **Un.7 - II** (Fig. 5-37)

Readjust tire on the rim (the right display bars light up permanently).

**Option 1:** Readjust the tire on the rim (normal program)

- Readjust the wheel according to the right direction indicator and make a double mark on the right side of the tire exactly perpendicular to and above the main shaft (Fig. 5-38).
- Remove the wheel from the machine.
- Readjust the tire on the rim until the double mark coincides with the valve (Fig. 5-39).
- Clamp the wheel on the balancer and readjust it so that the valve is exactly perpendicular to and above the main shaft.
- Press the **ENTER** key (1) to acquire the valve position.

Reading **Un.8** appears (Fig. 5-34).

- Spin the wheel (START) (check run). If weight minimization was carried out correctly (according to the program cycle), the machine automatically returns to the type of weight positioning previously selected and indicates the residual dynamic imbalance on the wheel.

- Balance the wheel according to the readings. Both weight minimization and balancing are accomplished.

Message **E9**

Message E9 means that at least one error occurred during the minimization cycle. Press the **STOP** key (5) to exit the minimization program and repeat minimization if necessary.

**Option 2: Do not** readjust the tire on the rim

- Press the **STOP** key (5) to exit the minimization program and return to the balancing program. The imbalance on the wheel is shown on the readout.
- Balance the wheel according to the readings.

Reading **H0**

The optimum minimization condition has been achieved and cannot be improved.

- Press the **STOP** key (5) to return to the balancing program and continue according to the readings.

## 10.0 TROUBLE SHOOTING

If a problem arises with the wheel balancer, proceed in the following order to solve the problem:

1. Rethink the last steps taken.  
Did you work according to the manual?  
Did the unit work as described and expected?
2. Check the unit according to the points listed in this chapter.
3. Call Technical Support at 800-225-5786.

### When switched on, nothing lights up.

1. Power switch in OFF position.
  - Set power switch in ON position.
2. No power cable connected.
  - Connect power cable to power outlet.
3. No mains power
  - Check power supply, power system fuses
4. Unit fuse(s) blown.
  - Replace unit fuse(s) (☞ 6.2).  
If the fuse(s) has (have) recently been replaced,
  - Call Technical Support at 800-225-5786. to check the unit.

### When switched on, a beep is heard for 1 second.

1. Configuration error.
  - Call Technical Support at 800-225-5786.

### Display appears to freeze or lock up.

1. The unit may be in a program, waiting for a specific action.
  - Finish the program currently in use.
  - Switch off the unit.  
Wait for 20 seconds, switch on the unit.  
Proceed.
2. Power to the balancer may have been interrupted.
  - Switch off the unit.  
Wait for 20 seconds, switch on the unit.  
Proceed.
  - If this happens frequently, have your power system checked. If that is okay, call technical service team.

### Gauge arm inputs differ from wheel dimensions stated on rim or tire.

1. Did you position the gauge arm correctly?
  - Refer to Chapter 5.6.1.
2. Check the offset input of the gauge arm by entering manually.
  - Refer to the scale on the gauge.
  - If not identical, proceed with step 4.

3. Check the diameter of the spot on the rim where the diameter has been measured.
  - If not identical, proceed with step 4.
4. Calibration is required.
  - Have the gauge arm calibrated.

### Balancing results are unreliable.

1. The balancer may not be installed properly.
  - Make sure the unit rests on its 3 feet only.
  - Make sure the floor is not relaying shocks or vibrations, for example from compressors or trucks passing close to the unit.
2. The wheel may be mounted incorrectly.
  - Check the hub, cones and adapters for play.
  - Use appropriate spacers to eliminate play.
  - Perform measuring unit calibration.
3. The electronics are faulty.
  - Call Technical Support at 800-225-5786..

### A mode or indicator is continuously shown on the screen.

1. A power fluctuation may have occurred.
  - Switch off the unit.  
Wait for 20 seconds, switch on the unit.
  - Call Technical Support at 800-225-5786.

## 10.1 SYSTEM MESSAGES

The wheel balancer can show messages to the operator. These may be error related (E-codes) or warnings (H-codes). The codes will be described in the following chapters.

Whenever a code appears:

- Make a note of it;
- Look up the code in the list. If the code is not described, call service team;
- Perform the steps described.

In special cases, or if the need arises, some operating modes or states can be changed by entering the appropriate codes (C Codes).

### 10.1.1 C CODES

#### Selecting and changing a code.

Example for **code C0** (Fig. 7-1)

- Press and hold down together the “**MODE**” (7) and “**FINE**” (8) keys for 7 seconds.

The C codes selection condition appears (Fig. 7-2).

- Press one of the “+” (4) or “-” (6) keys until the readout shows the desired code number (e.g.: C 0).
- Press the **ENTER** key (5) to acquire the selection.

The right number readout shows the current state, e.g.: “0” which in this case means switched off.

If the desired state is already on the readout:

- Press the **STOP** key (10, Fig. 7-1) once to return to C codes selection (Fig. 7-2), and a second time to definitively exit and return to the operating mode.

If the desired state is not that shown by the readout, but needs selecting, proceed as follows:

- Press one of the “+” or “-” keys until the right readout shows the desired condition (e.g.: “0”).

Now two options are possible:

#### Option 1

- Press the **ENTER** key to acquire the selection.
- Press the **STOP** key to return to the operating mode.

The operating mode change is complete and is saved until a new setting is entered. When the machine is switched off the settings are not deleted, and at each subsequent start up they appear as previously set up until changed again.

#### Option 2

Cancel selection of code C just set and return directly to the operating mode:

- Press the **STOP** key twice consecutively.

**Note:** Code **C4**, Compensation of the clamping means, cannot be transferred to the permanent memory.

Below are the change codes available and the relative selections possible.

#### Code C0

Setting operating modes preset by the factory:

- Select Code C0
- Select one of the following options:  
0\* = No action  
1 = Set the default values  
(state 1 appears briefly)

**Note:** The selection is permanently acquired.

#### Code C4

Compensation of residual unbalance, if any, in the clamping means.

High precision measurement.

Every time the clamping means are substituted, compensation must be deleted or carried out again with the new means fitted.

Resetting the operating state to 0 cancels the clamping means compensation.

The compensation is also cancelled following:

- Balancer calibration or recalibration,
- Unbalance optimization,
- Balancer switch off.

- Select Code C4
- Select one of the following options:

0 = Carry out compensation

1 = Compensation completed

0 = Switch off compensation again after the measuring run.

**Note:** The present operating mode cannot be transferred to the permanent memory.

**Code C7**

Volume of audible signal  
Scale of volume 0 to 100 (low – high),  
Normally set to 50\*

Example: Adjusting the volume to 60

- Select Code C7
- Set the desired value
- Press **ENTER**

**Note:** The selection is permanently acquired.

**Code C8**

Selecting the limit (threshold) value for suppression of minor unbalance readings in grams, or ounces. The unit of measurement (g or oz) depends on the setting (- 5.4.3).

**Grams:**

Range 3.50 to 20.0 g  
Factory-adjusted to 5.0\* g  
Select another limit, e. g.: 5.50 g

- Select Code C8
- Set the value 5.50
- Press **ENTER**

**Ounces:**

Range 0.12 to 0.71 oz  
Factory-adjusted to 0.18\* oz  
Select another limit, e. g.: 0.50 oz

- Select Code C8
- Set the value 0.50
- Press **ENTER**

**Note:** The selection is permanently acquired.

**Code C9**

Managing *WeightMiser*<sup>™</sup> features

**Code C11**

Main shaft stop position.  
The positioning brake stops the main shaft close to the correction position by initiating pulsing braking. The positioning brake is activated after switch on and after a measuring run has been carried out and found an unbalance greater than the limit value.

- Select Code C11
- Select one of the following options:  
0 = No positioning brake after measuring run.  
1\* = Positioning brake after measuring run for left plane.  
2 = Position brake after measuring run for right plane.

**Note:** The selection is permanently acquired.

**Code C12**

Measuring spin counter.

Example: 222,123 measuring runs completed:

- Select Code C12
- Select one of the following options:  
1 = Total number of measuring runs completed  
2 = Total number of measuring runs where balancing was successfully completed, indicated by OK  
3 = Total number of optimizations or minimizations  
4 = Total number of measuring runs in Service mode  
5 = Total number measuring runs since last calibration

Every measuring run completed is saved. Maximum count is 999,999 measuring runs. Once this number is reached, the counter is reset to zero. The information is primarily useful for statistical purposes, for example, to monitor the endurance of faulty parts, or monthly (yearly) use of the machine, etc. The measuring runs performed while the machine is switched on are transferred to the permanent memory and added when it is switched off.

**Note:** The total counter (option 1) cannot be deleted.

**Code C14**

See page 21

**Code C19**

Viewing *WeightMiser*<sup>™</sup> cumulated counters (consult the relative document).

**Code C20**

Viewing the WM<sup>™</sup> partial counters (consult the relative document).

**Code C21**

This code provides information about the program version and the balancer model name

- Go into code C21.  
Information about the software version appears.
- Press the “-” key to view the Kernel version.  
The information is visible for as long as the key is pressed.
- Press the “+” key or the “FINE” key to view the balancer model.

**Note:** The information is visible for as long as the key is pressed.

**Code C28**

Displays the error codes saved by the balancer (a maximum of 10) and clears the error memory.

The last 10 different error codes are saved in the error memory so that they can be called up and consulted by the wheel balancer operator for remote diagnosis of malfunctions.

The most recent error code is saved in memory location 1. Previous error codes are gradually shifted down the memory list.

- Go into code C28.

**REVIEWING THE ERROR COUNTERS**

- Press and release the "+" or "-" key to scroll through the list of errors.

**Note:** When the key is pressed the number of the error in the list is shown, whilst when the key is released the corresponding code appears.

- Press the **MODE** key to make the error number appear again (on the left) and the total number of times that error was repeated since the last time the memory was cleared (on the right).

**ZEROING THE ERROR COUNTERS**

- Press **ENTER**.
- Make the selection.
  - 0\* = Do not clear the error memory
  - 1 = Clear the error memory
- Press **ENTER**.

**10.1.2 E-CODES**

When the E-code is displayed, a low beep is generated.

Whenever a code appears:

- Write it down
- Look up the code in the list. If the code is not described, call service.
- Perform the steps described.

The setup of this chapter is:

Code

Description

- Step(s) to be performed.

Some error messages are displayed for approx. 3 seconds on the display of the right side.

- To clear the error code immediately (e.g.: open the wheel guard) or press the STOP key.

**E 9 (-7.1.3)****E10**

Gauge arm removed from idle position during wheel spin.

- Bring gauge arm to the idle position (fully in and down).
- Re-spin the wheel without touching the gauge arm.
- If the error appears again, have the gauge arm calibrated (by the service department). Display clears after several seconds.

**E11**

During ignition the gauge arm is not in the idle position.

- Move the gauge arm back carefully to the idle position.

The error should disappear within a few seconds.

- If the error appears again, contact the service department.

Note: By pressing **STOP** you can continue to use the machine but all the wheel data must be inserted manually (☞ 5.6.3).

**E 14** (☞ 7.1.3)

**E 21** (☞ 7.1.3)

**E22**

Speed low

The rotation speed of the wheel has not reached the minimum limit needed to enable balancing.

- Check that the brake (pedal) or wheel is not accidentally blocked.
- Check that something is not braking or obstructing the wheel.
- Check the power supply.
- Fit the wheel correctly.
- Contact Technical Support at 800-225-5786.

**E 23** (☞ 7.1.3)

**E24**

Velocity fluctuations

If the speed of the wheel to keep to the need to compensate.

- Check that the wheel is not obstructed or impeded by something.
- Check the power supply.
- Fit the wheel properly.
- Call Technical Support at 800-225-5786.

**E25**

Reverse error.

The shaft is rotating at a certain speed but in the wrong direction.

- Apply the brake.
- Contact Technical Support at 800-225-5786.

The display clears when rotation stops.

**E26**

No acceleration.

No shaft acceleration has been registered.

- Contact Technical Support at 800-225-5786

**E27**

Slipping registered.

The wheel slips on the shaft.

- Fit the wheel correctly.

**E28**

Speed limit reached.

- Contact Technical Support at 800-225-5786.

**E50**

Manufacturer's calibration incomplete

- Contact Technical Support at 800-225-5786.

**E51**

Calibration failed

- Switch unit off, wait for 20 seconds.
- Switch unit on.
- Retry calibration, or:
- Contact Technical Support at 800-225-5786

**E52**

The calibration weight is on the opposite side to the calibration carried out by the manufacturer.

- Fit the User Calibration Weight correctly on the left side of the flange. Repeat Calibration.
- Contact Technical Support at 800-225-5786

**E82**

Fault during self-test at start-up.

- Switch unit off, wait for 20 seconds.
- Switch unit on.

**E92**

During the second attempt the gauge arm for distance

and rim diameter was still not in the home position.

Both gauge arms are rendered inoperative.

- Wait 5 seconds, or press the STOP key to continue.

**E500**

**E501**

**E502**

**E503**

### 10.1.4 H CODES - WARNING

#### H0

Wheel silent running cannot be improved with balancing optimization.

#### H1

Further optimization is not recommended but is possible.

#### H2

Weight minimisation is recommended, further optimization does not bring improvements.

#### H22

Unclamping is disabled.  
A clamping device is fitted on the balancer where the tie rod holds the device on the main shaft (e.g. USV or SCA); unintentional unclamping could damage the tie rod.

#### H33

The SONAR doesn't work.

#### H34

Sonar can't read: hood too fast.

#### H35

Sonar measure data out of range.

#### H80

Recalibration was not set up. As a result, it cannot be performed by the operator.  
Press the STOP key to clear the message.  
Call the service team for machine calibration.

#### H82

The self-test was disturbed (e.g.: by turning the wheel). The message is displayed for 3 seconds, then the measurement is repeated (max. 10 times) or aborted by pressing the STOP key.

#### H90

Wheel acceleration was too slow, or braking was too weak after a measuring run.

If the main shaft does not reach the required speed, check that the brake is not activated or the weight of the wheel is too great. In this case:

Release the brake.

Make sure that the shaft with the wheel clamped on it can rotate freely.

Turn the wheel by hand, then run the START.

If the error cannot be eliminated, call the service team.

#### H91

Speed variations during measuring run. The brake may be ON.

Release the brake.

Make sure that the shaft with the wheel clamped on it can rotate freely.

Repeat the run.

## 11.0



This balancer does not require any special maintenance but the following precautions are required:

Periodically wash all plastic parts with a glass cleaner, wipe with a dry cloth.

Clean all adapters regularly with a non flammable liquid detergent. Lubricate with a thin layer of oil.

Periodically perform a routine calibration as outlined on pages 21 of this manual..

**NOTES:**



**NOTES:**

## WARRANTY/SERVICE AND REPAIR

### Snap-on® Tools Limited Two (2) Year Warranty

Snap-on Tools Company (the "Seller") warrants only to original purchasers who use the Equipment in their business that under normal use, care and service, the Equipment (except as otherwise provided herein) shall be free from defects in material and workmanship for two years from the date of original invoice. Seller does not provide any warranty for accessories used with the Equipment that are not manufactured by Seller.

SELLER'S OBLIGATIONS UNDER THIS WARRANTY ARE LIMITED SOLELY TO THE REPAIR OR, AT SELLER'S OPTION, REPLACEMENT OF EQUIPMENT OR PARTS WHICH TO SELLER'S SATISFACTION ARE DETERMINED TO BE DEFECTIVE AND WHICH ARE NECESSARY, IN SELLER'S JUDGMENT, TO RETURN THIS EQUIPMENT TO GOOD OPERATING CONDITION. NO OTHER WARRANTIES, EXPRESS OR IMPLIED OR STATUTORY, INCLUDING WITHOUT LIMITATION ANY IMPLIED WARRANTY OF MERCHANTABILITY OR FITNESS FOR A PARTICULAR PURPOSE, SHALL APPLY AND ALL SUCH WARRANTIES ARE HEREBY EXPRESSLY DISCLAIMED.

SELLER SHALL NOT BE LIABLE FOR ANY INCIDENTAL, SPECIAL OR CONSEQUENTIAL COSTS OR DAMAGES INCURRED BY PURCHASERS OR OTHERS (including, without limitations, lost profits, revenues, and anticipated sales, business opportunities or goodwill, or interruption of business and any other injury or damage).

This warranty does not cover (and separate charges for parts, labor and related expenses shall apply to) any damage to, malfunctioning, in-operability or improper operation of the Equipment caused by, resulting from or attributable to (A) abuse, misuse or tampering; (B) alteration, modification or adjustment of the Equipment by other than Seller's authorized representatives; (C) installation, repair or maintenance (other than specified operator maintenance) of the Equipment or related equipment, attachments, peripherals or optional features by other than Seller's authorized representatives; (D) improper or negligent use, application, operation, care, cleaning, storage or handling; (E) fire, water, wind, lightning or other natural causes; (F) adverse environmental conditions, including, without limitation, excessive heat, moisture, corrosive elements, dust or other air contaminants, radio frequency interference, electric power failure, power line voltages beyond those specified for the Equipment, unusual physical, electrical or electromagnetic stress and/or any other condition outside of Seller's environmental specifications; (G) use of the Equipment in combination or connection with other equipment, attachments, supplies or consumables not manufactured or supplied by Seller; or (H) failure to comply with any applicable federal, state or local regulation, requirement or specification governing the equipment and related supplies or consumables.

Repairs or replacements qualifying under this Warranty will be performed on regular business days during Seller's normal working hours within a reasonable time following purchaser's request. All requests for Warranty service must be made during the stated Warranty period. Proof of purchase date is required to make a Warranty request. This Warranty is nontransferable.

**Notice:** The information contained in this document is subject to change without notice. **Snap-on** makes no warranty with regard to this material. **Snap-on** shall not be liable for errors contained herein or for incidental consequential damages in connection with furnishings, performance, or use of this material.

This document contains proprietary information which is protected by copyright and patents. All rights are reserved. No part of this document may be photocopied, reproduced, or translated without prior written consent of **Snap-on**.

Snap-on Equipment, 309 Exchange Ave. Conway, Arkansas 72032  
Customer Service and Technical Support Line 800-225-5786

Assembled in USA. Snap-on and Wrench "S" are trademarks of Snap-on Incorporated.  
©Snap-on Incorporated 2014. All Rights Reserved.  
Printed in United States. Snap-on, 2801 80th St., Kenosha, WI 53143 [www.snapon.com](http://www.snapon.com)