

**VPI SYSTEM I / VPI SYSTEM II
COMPUTER WHEEL BALANCER**

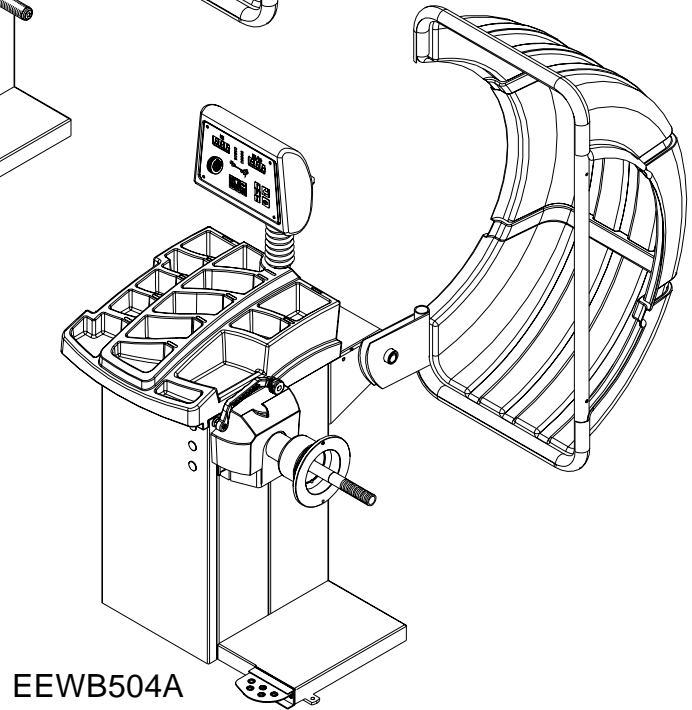
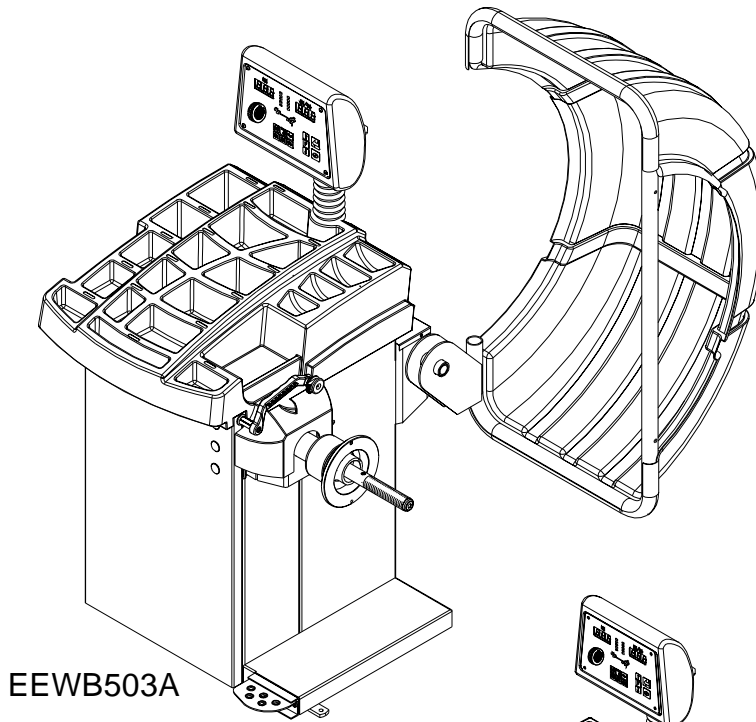
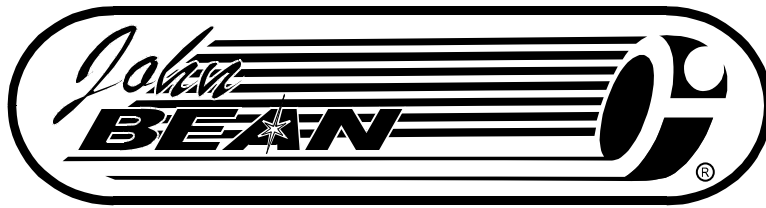

PARTS REFERENCE

Form 5788-3

All information contained or disclosed in this document is considered confidential and proprietary by Snap-on Tools Company. All manufacturing, use, reproduction, and sales rights are reserved by Snap-on Tools Company and the information contained herein shall not be used in whole or in part without the express written consent of Snap-on Tools Company.

Contents

DISPLAY, TOUCH PANEL AND WEIGHT TRAY ASSEMBLY	1
LOWER CABINET ASSEMBLY	2
WHEEL GUARD ASSEMBLY	4
VIBRATORY AND MOTOR ASSEMBLY	5
2D SAPE ASSEMBLY	6
SHAFT ADAPTERS AND ACCESSORIES	7
PARTS IN ALPHABETICAL ORDER	9
PARTS IN NUMERICAL ORDER	13

DISPLAY, TOUCH PANEL AND WEIGHT TRAY ASSEMBLY

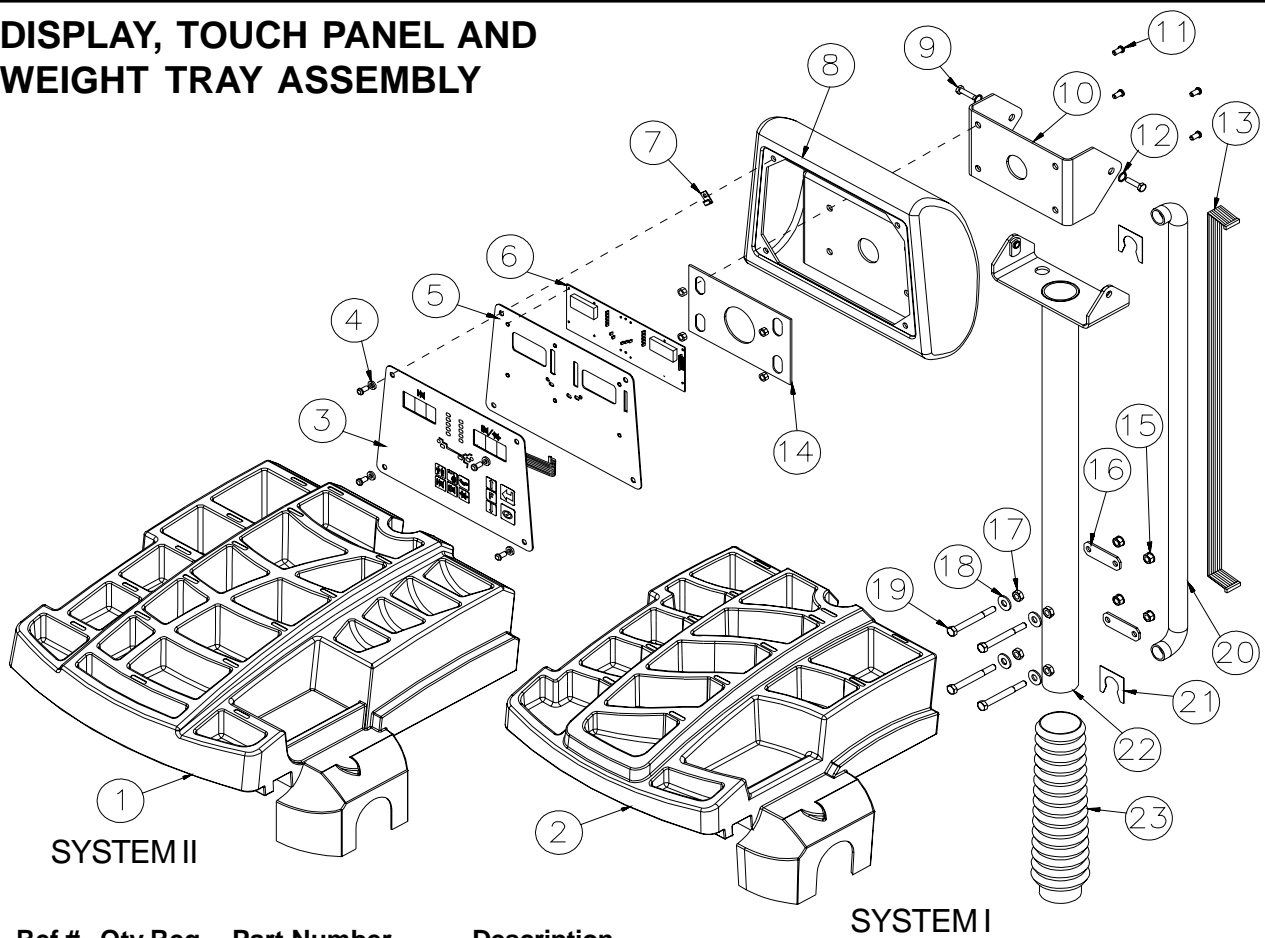

Ref #	Qty Req.	Part Number	Description
1	1	EAC0053J08A	Weight Tray Mid Digital
2	5	EAC0053J07A	Weight Tray - JBC System I
3	1	EAA0255J18A	Membrane - JBC System I & II
4	4	1-11744A	Washer - Nylon Flat
5	1	EAS2021J29A	Backing Plate
6	1	EAP0207P00A	PCB Assy - Display, JBC
7	4	1-07039A	Nut - Tinnerman 1/4 - 20
8	1	EAC0053J11A	Housing-display, JBC System I & II
9	2	1-1401	Screw-HHC,3/8-16 X 1
10	1	EAS2021J06A	Bracket-top Adjuster, Display
11	8	1-2509	Screw-BHCS,1/4-20 X 5/8
12	2	977757	Ring-snap,25 X 1.20
13	1	EAW0233J04A	Display Cable - JBC
14	1	EAS2021J12A	Bracket Wldmt-plate, Display
15	4	1290404	Nut & L/Washer Assy 5/16 - 18
16	2	EAS2021J63A	Clamp,Tower
17	4	340774	Nut - Hex, 5/16 - 18
18	4	234123	Washer, Flat 5/16
19	4	1-1115	Bolt-hex,5/16-18x3,Unc 2a, Tap
20	1	8-00734A	Tubing - Flexible
21	2	EAS2021J64A	Plate, Tube Stop
22	1	EAS2021J16A	Display Wldmt-tower, S1, M1
23	1	5-00838A	Bellow - Cover Tube
*		EAS2021J24A	Sheet - Fireshield

LOWER CABINET ASSEMBLY

Includes Power Supply / Brake

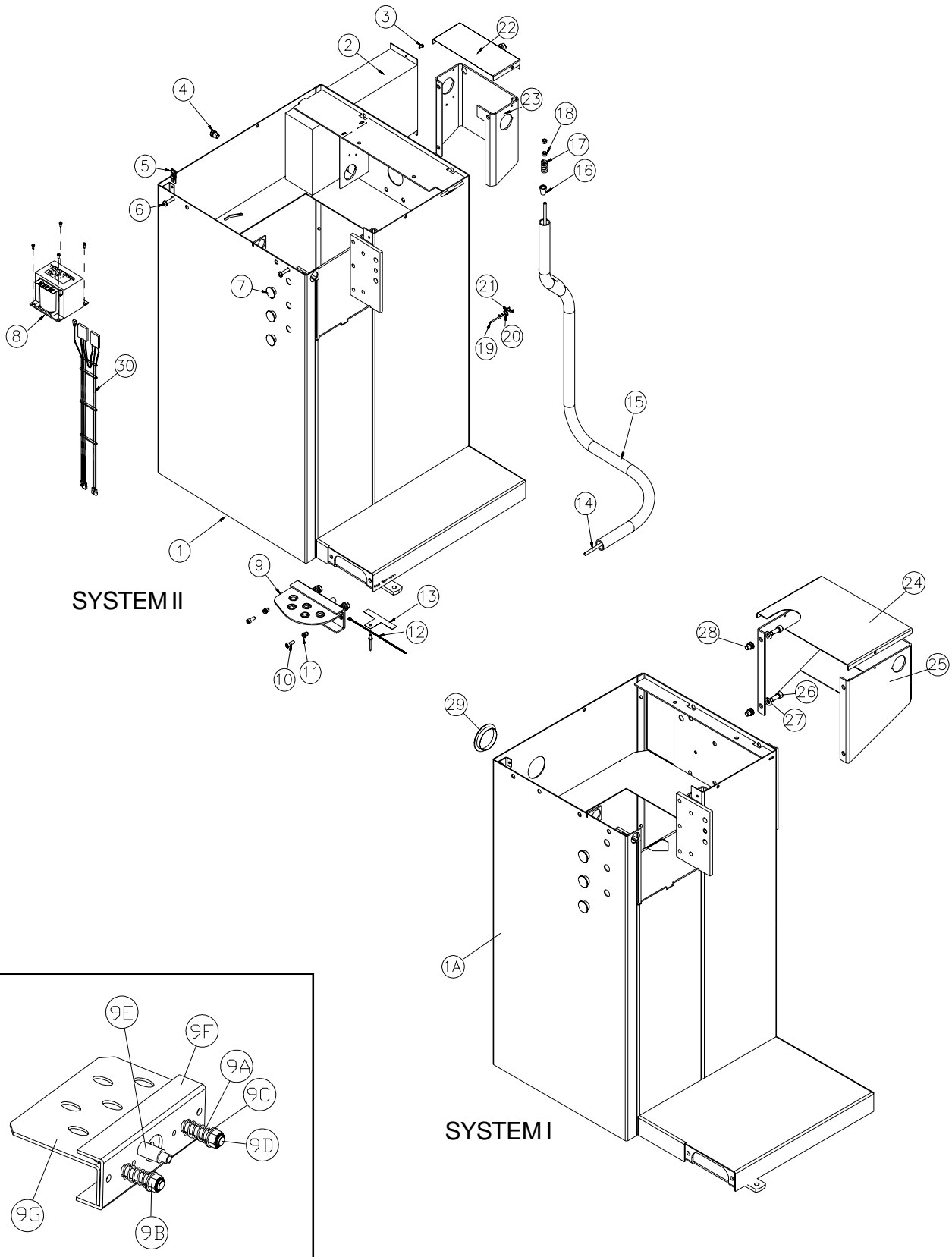

LOWER CABINET ASSEMBLY Includes Power Supply / Brake

<u>Ref #</u>	<u>Qty Req.</u>	<u>Part Number</u>	<u>Description</u>
1	1	EAS2027G63A	Weldment Cabinet Md
1A	1	EAS2027G00A	Cabinet-balancer, S1a
2	1	EAA0255J23A	Electronic Unit Y2k Bal
*	1	EAP0201D10B	PCB Ass'y - Power Interface
*	1	EAP0201D00C	PCB Ass'y - Processor
*	1	EAW0233J06A	Cable - IEC, Jumper
*	1	EAW0233J05A	Cable - IEC Module Power Interfa
*	1	2-01429A	Capacitor - Start, 10uf 400v
*	1	2-01529A	Capacitor - Start 20uf 400v
*	1	2-16851A	Power Entry Module
*	2	2-19851A	Fuse - time Delay,5.00a 5 X 20mm
	1	EAL0341J37A	Label - fuse 5 AMP
*	4	1-7861	Standoff - Hex, M4 X 10mm
*	1	2-17947A	Connector - 10 Pin, Wago 733-110
*	1	2-40848A	Connector-5 Pin, Wago 731-605
3	6	1-3724	Screw - Self Tap,5 X 10mm
4	4	1-17659A	Nutsert - M10
5	4	1-6739	Nut - Tinnerman,1/4-20,J-type
6	4	1-2509	Screw - Bhcs,1/4-20 X 5/8
7	6	8-7216	Plug - Hole,16mm
8	1	7-15601A	Transformer 500va
9	1	EAA0263G07A	Brake Pedal Ass'y
9A	2	1-6668	Compression Spring
9B	2	1-11633	Hex Nut
9C	2	1-10041	Washer, Plain M8
9D	2	1-18209	Screw, Hex Head Socket - M8 X 45
9E	2	EAM0005D18A	Spacer
9F	1	EAS2027G18A	Brake Pedal Support Bracket
9G	1	EAS2027G31A	Chamfered Brake Pedal
10	2	1-16309	Screw - Hex Hd Cap, M6 X 16 8.8
11	2	1-17559A	Nutsert - M6
12	1	5-1145	Cable Tie - 8" X .11
13	1	EAS2027G36A	Sheet - Support,Tube
14	1	EAA0260D58A	Cable - Brake, S1
15	1	8-634-01	Protective Pipe For Cables (Old Style)
16	2	EAM0005D18A	Spacer
17	1	1-6668	Compression Spring
18	2	1-11633	Nut - Hex
19	2	1-7558	Pop Rivet - 3/16"
20	1	1-1548	Washer - Ext,Shakeproof 6mm
21	1	2-23201	Terminal Lug-6.3mmx8mm,Pop Riv
22	1	EAS2021J44A	Backpack Top
23	1	EAS2021J43A	Backpack Base
24	1	EAS0207G38A	Plate - Wheelguard Cover
25	1	EAA0263G02A	Wheelguard Support
26	4	1-17709	Screw - Hshc M8 X 20mm
27	4	1-17741	Washer, 8mm
28	4	1-18359A	Nutsert - M8
29	1	1-2676	Plug - Hole 2" Dia
30	1	EAW0233J07A	Harness - Wiring, Transformer
*	1	8-23562A	Label - Warning
*	1	EAL0341J07A	Label - Warning, Disconnect Power
*	1	8-23662A	Label - Safety
*	1	8-23762A	Label Earth Symbol
*	1	00111245000	Label - Caution, Electric
*	1	EAX0039J01A	Cord - Power, 230v

ELECTRONIC BOX COMPONENTS

WHEEL GUARD ASSEMBLY

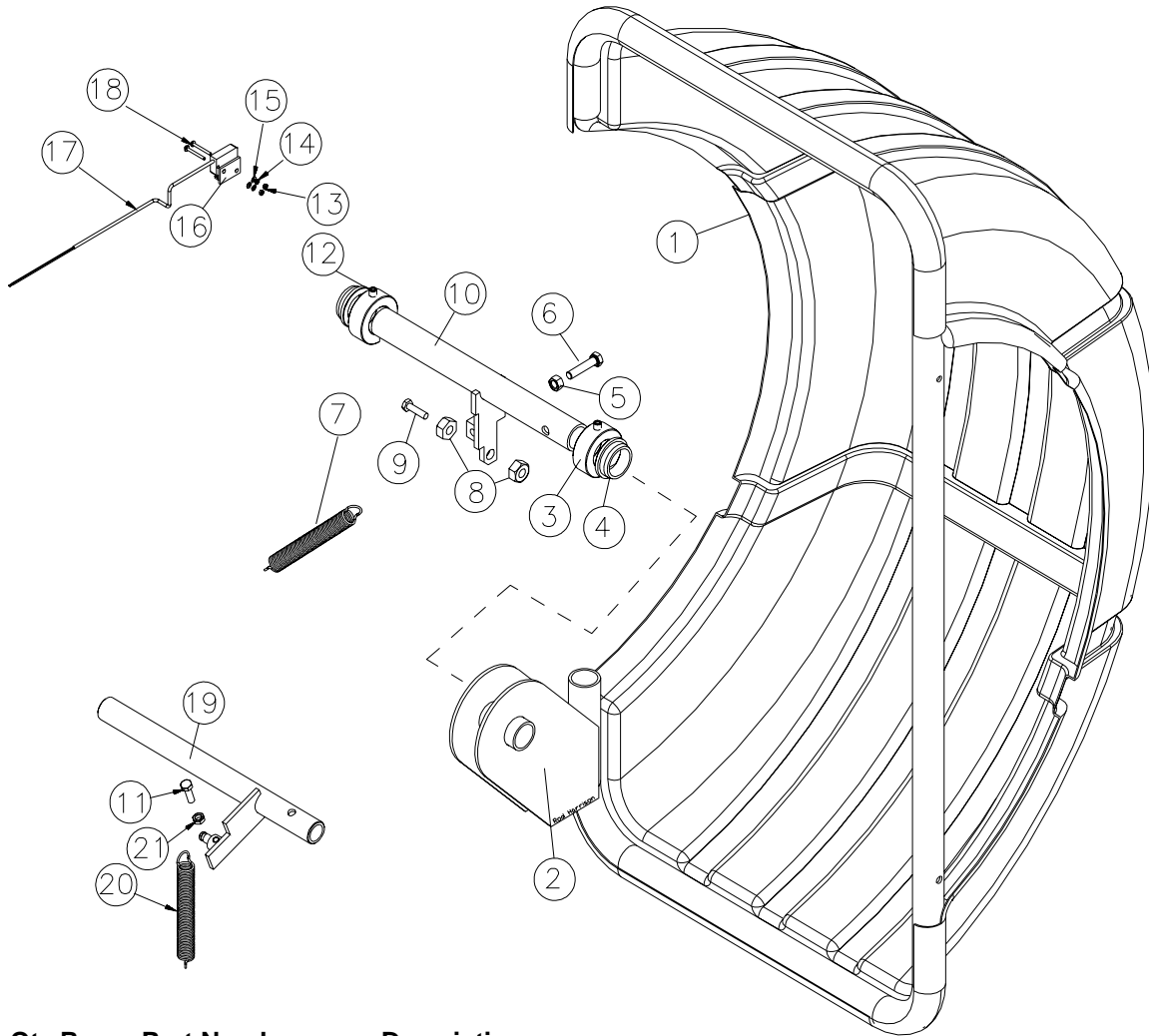

Ref #	Qty Req.	Part Number	Description
1	1	EAC0053J09A	Cover-wheelguard, Y2k
2	1	EAS2021J15A	Weldment-wheelguard, M1(SYSTEM II)
3	2	EAM0006G02A	Wheelguard Tube Ring Nut
4	2	EAC0060G03A	Bushing, Wheelguard Tube
5	1	1-11833	Nut, - M8 - 1.25
6	1	1-01515A	Screw - HHMS 8M - 1.25 X 50mm
7	1	EAM003J21A	Spring, VPI II
8	1	1-5733A	Nut Hex 3/8
9	1	1-33201	Screw - Hhm M8 X 1.25 X 50mm
10	1	EAA0255J29A	Tube-wheelguard Support, VPI II
11	1	1-32701	Screw - HHMS 8M X 25mm
12	2	1-47810	Screw, Set, M8 X 8mm Flat Pt
13	2	1-11233	Nut-hex, M3 Din 934
14	2	1-1248	Washer-ext, Shakeproof, M3
15	2	1-9541	Washer-flat, M3 Din 125a
16	1	EAC0053J16A	Plate-switch Mounting
17	1	EAW0233J08A	Microswitch
18	2	1-7104	Screw
19	1	EAA0263G10A	Weldment-s1 Wheelguard Support (SYSTEM I)
20	1	EAM0003J18A	Spring - Extension Wheelguard (SYSTEM I)
21	1	1-15933A	Nut - Hex, M8 X 1.25 DIN 936

VIBRATORY AND MOTOR ASSEMBLY EAA0277D65A

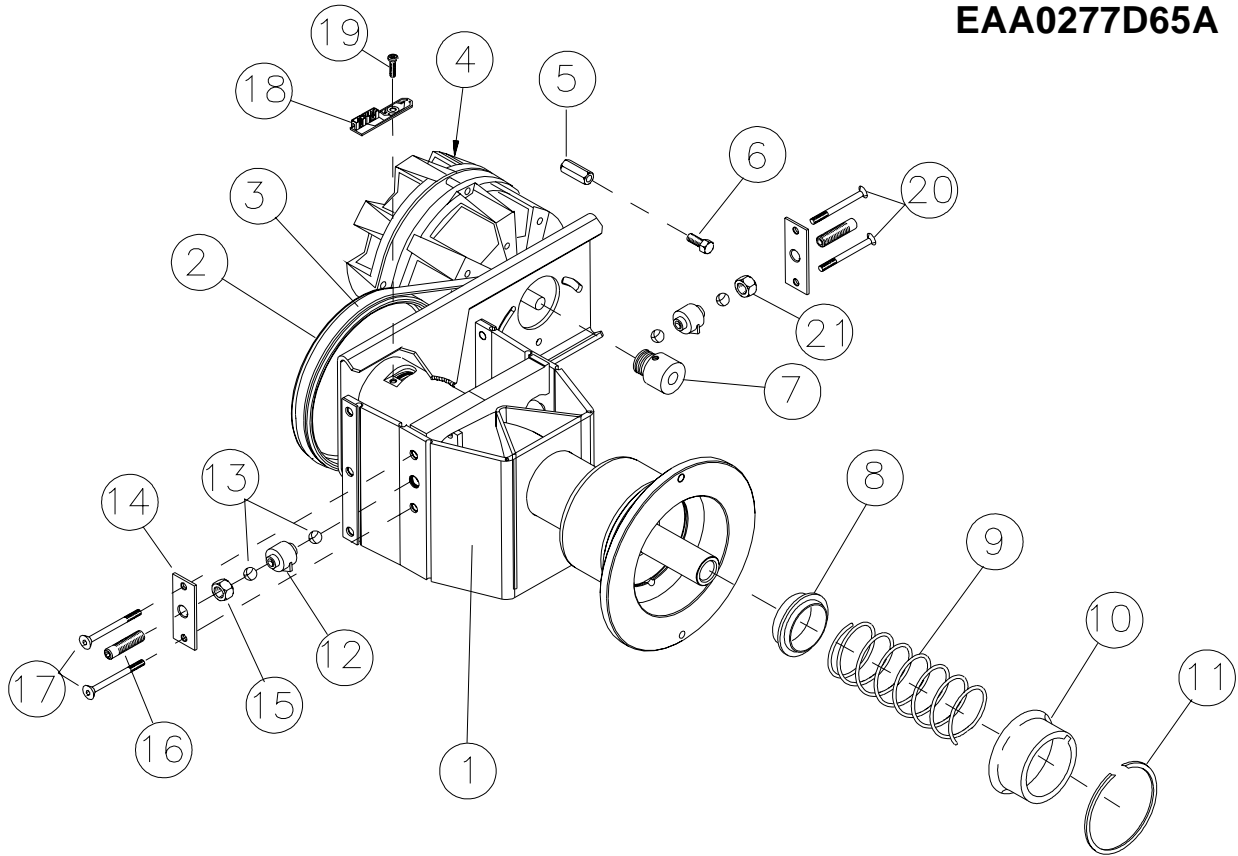

Ref #	Qty Req.	Part Number	Description
1	1	EAA0277D65A	Vibrator Ass'y-motorized
2	1	EAM0005D12A	Drive Wheel
3	1	8-3531	Multirib Belt 5 PJ 711 Din 7867
4	1	EAA0266D29A	Motor, AC 120w 1 Ph 220-240v - 50/60 Hz
5	2	EAM0005D09A	Motor Distance bolt
6	1	1-30701	Screw Hex HD M 6 X 12
7	1	EAM0005D08A	Motor Pulley
8	1	EAC0058D03A	Spring Centering Ring
9	1	1-6498	Spring - Compression 5 X 63 X 120
10	1	EAS2025D14A	Spring Case Deep Draw
11	1	1-13077	Snap Ring
12	1	EAA0260D59A	Transducer
13	4	8-1144	Ball, Steel
14	2	1-2967	Pretension Spring
15	1	1-11833	Nut-Hex M 10 X 1 DIN 934
16	2	EAM0005D07A	Setscrew - Hex Socket M 10 X 1
17	2	1-19903A	Screw Hex Socket / Countersunk M 4 X 65
18	1	EAA0260D09A	Encoder PCB
19	1	1-13004	Screw Phillip Pan HD M 4 X 6
20	2	1-17403	Screw Hex Socket / Countersunk M 4 X 25
21	1	1-4034	Nut - Hex M 10 X 1 DIN 439
*	1	EAW0239D00A	Ribbon Cable Vibratory
**	1	EAA0260D56A	Brake lever A cpl.
**	1	EAA0260D57A	Brake lever B cpl.

** BRAKE PARTS NOT SHOWN

2D SAPE ASSEMBLY

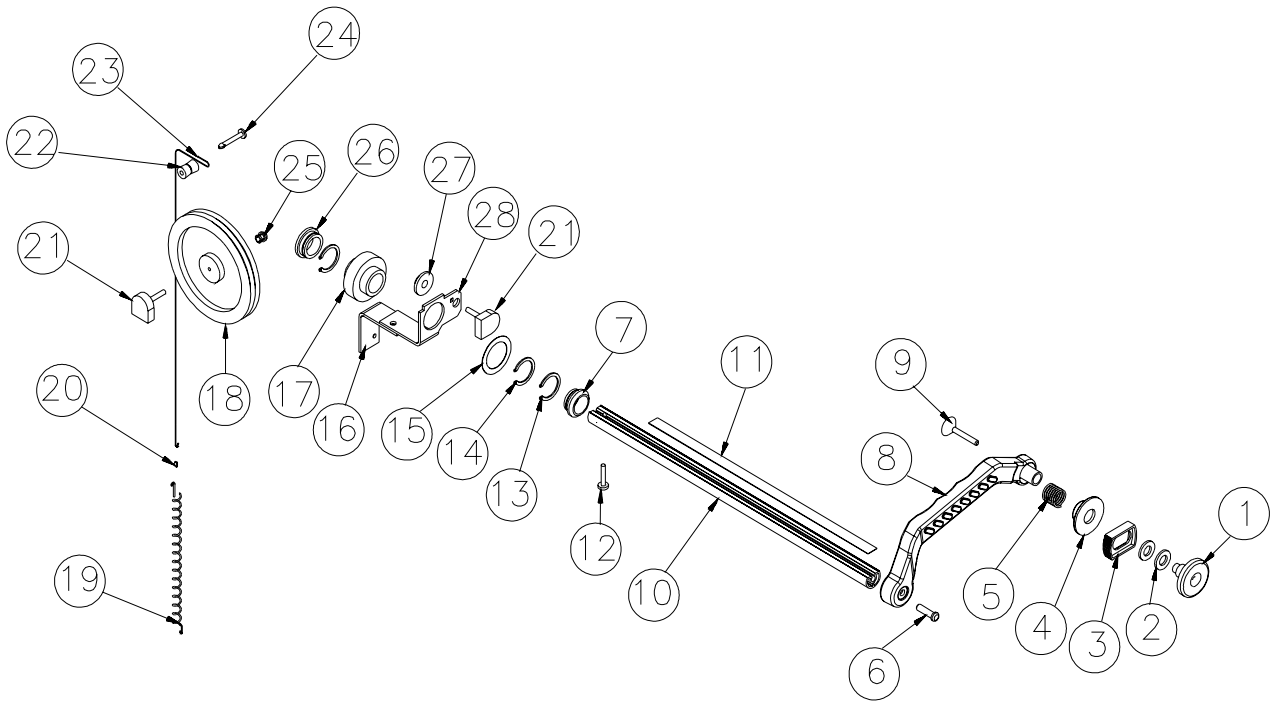

Ref #	Qty Req.	Part Number	Description
1		EAC0058D11A	Disk - Touching
2	1	1-11841	Washer - Plain, M10.5 Din 125
3	1	EAC0058D09A	Ejector
4	1	EAC0053J06A	Adjuster - Arm, Sape
5	1	1-06868A	Spring - Comp D145e, Din 2098
6	1	1-3824	Screw - Self Tap, 6 X 12mm
7	1	EAM0005D38A	Bushing 1
8	1	EAC0053J03A	Arm-sape
9	1	1-3624	Screw - Fhms, 5x40mm, Self Tap
10	1	EAM0005D37A	Rod - M1 (VPI II)
10a	1	EAM0005D36A	Rod- SAPE (VPI I)
11	1	EAL0345D01A	Measure Tape - Sape
12	2	1-13609	Screw-shcs, M4-16 8.8
13	2	1-4577	Ring-snap, 25 X 1.20
14	1	1-13377A	Circlip - 27 X 1.20
15	1	1-07162A	Shim Ring - 28 X 40 X
16	1	EAS2021J32A	Angle - 2d Sape
17	1	EAC0058D12A	Cog Wheel - 56 Tooth
18	1	EAC0058D06A	Rope - Reel 290mm
19	1	1-03267A	Tension Spring - Sape
20	1	2-07557A	Sleeve - Compression, Oval
21	2	EAA0266D20A	Rotative Transducer - Assy
22	1	EAM0005D35A	Guiding Reel
23	2	6-00404A	2.700 Ft Rope-hemingway Dyneema, Type 40
24	1	8-1940	Pin-pushin, Nylon, .165 X 1.062
25	2	2-07657A	Clamping Device With Nut
26	1	EAM0005D39A	Bushing 2
27	1	EAC0058D13A	Cog Wheel-28 Tooth
28	1	EAS2021J36A	Mounting Brkt 2D SAPE

SHAFT ADAPTERS AND ACCESSORIES

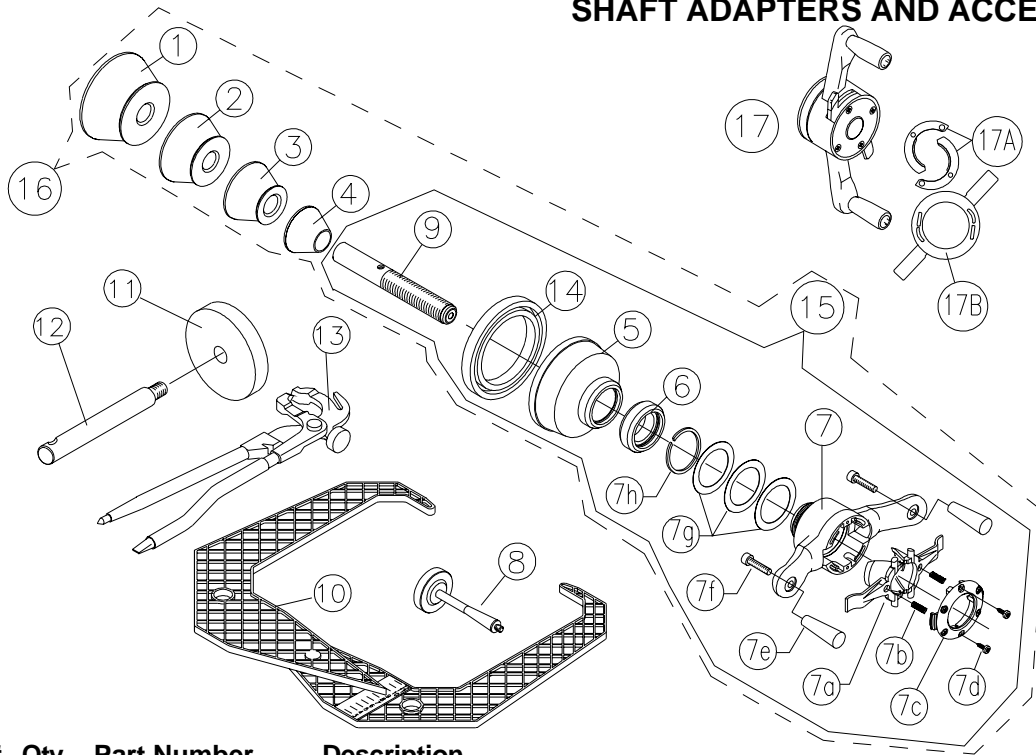

Ref #	Qty	Part Number	Description
1	1	EAM0003J08A	Cone-Truck, 29 Deg
2	1	EAM0003J07A	Cone-Large
3	1	EAM0003J06A	Cone-Small
4	1	EAM0003J05A	Cone-Small
5	1	EAC0058D07A	Cup-Pressure,Haweka
5A	1	00061078000	Retainer Cup & Pressure Ring(VPI System I) (Early)
*	1	00061076000	Retainer Cup (VPI System I) (Early)
*	1	00061077000	Pressure Ring (VPI System I) (Early)
6	1	EAC0058D08A	Disk Pressure
7	1	EAA0263G66A	Quicknut W/ Handles, 40 mm (VPI System II)
7	1	00061072000	Wing Nut (VPI System I) (Early)
7a	2	7409019-020	Clamp jaws set
7b	2	1611128	Disc, Spring
7c	2	ST0027000	Cover
7d	1	ST7417071	Screw
7e	2	00112322000	Handle
7f	2	ST7205389	Screw, Handle
7g	3	ST0027005	Spacer
7h	1	ST7022499	C - Clip
8	1	EAM0005D40A	Calibration Weight
9	1	EAM0005D15A	Threaded Shaft, 40mm
10	1	EAA0247G21A	Caliper-Rim Width
11	4	EAC0060G02A	Flange - Cover,Access
12	4	EAM0006G01A	Hook - Accessory Storage
13	1	00058839000	Tool - PDQ Weight
14	1	EAC0058D15A	Rubber Ring
15	1	EAA0263G79A	Quick Nut Kit
16	1	EAA0255J33A	Adapter Assy'
17	1	8-02140A	Wing Nut (old)
17A	2	00110192000	Insert
17B	1	00110194000	Cam
*	1	ZEEWB504A9	Lit Pack - ZEEWB504A9
*	1	ZEEWB503A9	Lit Pack - ZEEWB503A9

PARTS IN ALPHABETICAL ORDER

Description	Part Number
2.700 Ft Rope-hemingway Dyneema, Type 40	* 6-00404A
Adapter Assy'	* EAA0255J33A
Adjuster - Arm, Sape	EAC0053J06A
Angle - 2d Sape	* EAS2021J32A
Arm-sape	EAC0053J03A
Backing Plate	* EAS2021J29A
Backpack Base	* EAS2021J43A
Backpack Top	* EAS2021J44A
Ball, Steel	8-1144
Bellow - Cover Tube	* 5-00838A
Bolt-hex,5/16-18x3,Unc 2a, Tap	* 1-1115
Bracket Wldmt-plate, Display	* EAS2021J12A
Bracket-top Adjuster, Display	* EAS2021J06A
Brake lever A cpl.	EAA0260D56A
Brake lever B cpl.	EAA0260D57A
Brake Pedal Ass'y	EAA0263G07A
Brake Pedal Support Bracket	* EAS2027G18A
Bushing 1	* EAM0005D38A
Bushing 2	* EAM0005D39A
Bushing, Wheelguard Tube	* EAC0060G03A
C - Clip	* ST7022499
Cabinet-balancer, S1a	* EAS2027G00A
Cable - Brake, S1	EAA0260D58A
Cable - IEC Module Power Interfa	* EAW0233J05A
Cable - IEC, Jumper	* EAW0233J06A
Cable Tie - 8" X .11	* 5-1145
Calibration Weight	EAM0005D40A
Caliper-Rim Width	* EAA0247G21A
Cam	00110194000
Capacitor - Start 20uf 400v	2-01529A
Capacitor - Start, 10uf 400v	2-01429A
Chamfered Brake Pedal	* EAS2027G31A
Circlip - 27 X 1.20	* 1-13377A
Clamp jaws set	* 7409019-020
Clamp, Tower	* EAS2021J63A
Clamping Device With Nut	* 2-07657A
Cog Wheel - 56 Tooth	EAC0058D12A
Cog Wheel-28 Tooth	EAC0058D13A
Compression Spring	* 1-6668
Compression Spring	* 1-6668
Cone-Large	EAM0003J07A
Cone-Small	EAM0003J05A
Cone-Small	EAM0003J06A
Cone-Truck, 29 Deg	EAM0003J08A
Connector - 10 Pin, Wago 733-110	* 2-17947A
Connector-5 Pin, Wago 731-605	* 2-40848A
Cord - Power, 230v	EAX0039J01A
Cover	* ST0027000
Cover-wheelguard, Y2k	* EAC0053J09A
Cup-Pressure, Haweka	EAC0058D07A
Disc, Spring	* 1611128
Disk - Touching	EAC0058D11A

Description	Part Number
Disk Pressure	EAC0058D08A
Display Cable - JBC	* EAW0233J04A
Display Wldmt-tower, S1, M1	* EAS2021J16A
Drive Wheel	* EAM0005D12A
Ejector	EAC0058D09A
Electronic Unit Y2k Bal	EAA0255J23A
Encoder PCB	EAA0260D09A
Flange - Cover,Access	* EAC0060G02A
Fuse - time Delay,5.00a 5 X 20mm	2-19851A
Guiding Reel	* EAM0005D35A
Handle	00112322000
Harness - Wiring, Transformer	EAW0233J07A
Hex Nut	* 1-11633
Hook - Accessory Storage	* EAM0006G01A
Housing-display, JBC System I & II	* EAC0053J11A
Insert	00110192000
Label - Caution, Electric	* 00111245000
Label - fuse 5 AMP	* EAL0341J37A
Label - Safety	* 8-23662A
Label - Warning	* 8-23562A
Label - Warning, Disconnect Power	* EAL0341J07A
Label Earth Symbol	* 8-23762A
Lit Pack - ZEEWB503A9	* ZEEWB503A9
Lit Pack - ZEEWB504A9	* ZEEWB504A9
Measure Tape - Sape	* EAL0345D01A
Membrane - JBC System I & II	EAA0255J18A
Microswitch	EAW0233J08A
Motor Distance bolt	* EAM0005D09A
Motor Pulley	EAM0005D08A
Motor, AC 120w 1 Ph 220-240v - 50/60 Hz	EAA0266D29A
Mounting Brkt 2D SAPE	* EAS2021J36A
Multirib Belt 5 PJ 711 Din 7867	8-3531
Nut - Hex	* 1-11633
Nut - Hex M 10 X 1 DIN 439	* 1-4034
Nut - Hex, 5/16 - 18	* 340774
Nut - Hex, M8 X 1.25 DIN 936	* 1-15933A
Nut - Tinnerman 1/4 - 20	* 1-07039A
Nut - Tinnerman,1/4-20,J-type	* 1-6739
Nut & L/Washer Assy 5/16 - 18	* 1290404
Nut Hex 3/8	* 1-5733A
Nut, - M8 - 1.25	* 1-11833
Nut-Hex M 10 X 1 DIN 934	* 1-11833
Nut-hex, M3 Din 934	* 1-11233
Nutsert - M10	* 1-17659A
Nutsert - M6	* 1-17559A
Nutsert - M8	* 1-18359A
PCB Ass'y - Power Interface	EAP0201D10B
PCB Ass'y - Processor	EAP0201D00C
Pcb Assy - Display, Jbc	EAP0207P00A
Pin-pushin, Nylon, .165 X 1.062	* 8-1940
Plate - Wheelguard Cover	* EAS0207G38A
Plate, Tube Stop	* EAS2021J64A
Plate-switch Mounting	* EAC0053J16A
Plug - Hole 2" Dia	* 1-2676
Plug - Hole,16mm	* 8-7216
Pop Rivet - 3/16"	* 1-7558

Description	Part Number
Power Entry Module	2-16851A
Pressure Ring (VPI System I) (Early)	00061077000
Pretension Spring	* 1-2967
Protective Pipe For Cables (Old Style)	* 8-634-01
Quick Nut Kit	EAA0263G79A
Quicknut W/ Handles, 40 mm (VPI System II)	EAA0263G66A
Retainer Cup & Pressure Ring(VPI System I) (Early)	00061078000
Retainer Cup (VPI System I) (Early)	00061076000
Ribbon Cable Vibratory	EAW0239D00A
Ring-snap,25 X 1.20	* 1-4577
Ring-snap,25 X 1.20	* 977757
Rod - M1(VPI II)	EAM0005D37A
Rod- SAPE (VPI I)	EAM0005D36A
Rope - Reel 290mm	EAC0058D06A
Rotative Transducer - Assy	EAA0266D20A
Rubber Ring	EAC0058D15A
Screw	* 1-7104
Screw	* ST7417071
Screw - Bhcs,1/4-20 X 5/8	* 1-2509
Screw - Fhms,5x40mm,Self Tap	* 1-3624
Screw - Hex Hd Cap, M6 X 16 8.8	* 1-16309
Screw - Hhm M8 X 1.25 X 50mm	* 1-33201
Screw - HHMS 8M - 1.25 X 50mm	* 1-01515A
Screw - HHMS 8M X 25mm	* 1-32701
Screw - Hshc M8 X 20mm	* 1-17709
Screw - Self Tap,5 X 10mm	* 1-3724
Screw - Self Tap,6 X 12mm	* 1-3824
Screw Hex HD M 6 X 12	* 1-30701
Screw Hex Socket / Countersunk M 4 X 25	* 1-17403
Screw Hex Socket / Countersunk M 4 X 65	* 1-19903A
Screw Phillip Pan HD M 4 X 6	* 1-13004
Screw, Handle	* ST7205389
Screw, Hex Head Socket - M8 X 45	* 1-18209
Screw, Set, M8 X 8mm Flat Pt	* 1-47810
Screw-BHCS,1/4-20 X 5/8	* 1-2509
Screw-HHC,3/8-16 X 1	* 1-1401
Screw-shcs, M4-16 8.8	* 1-13609
Setscrew - Hex Socket M 10 X 1	* EAM0005D07A
Sheet - Fireshield	* EAS2021J24A
Sheet - Support,Tube	* EAS2027G36A
Shim Ring - 28 X 40 X	* 1-07162A
Sleeve - Compression,Oval	* 2-07557A
Snap Ring	* 1-13077
Spacer	* EAM0005D18A
Spacer	* EAM0005D18A
Spacer	* ST0027005
Spring - Comp D145e, Din 2098	* 1-06868A
Spring - Compression 5 X 63 X 120	* 1-6498
Spring - Extension Wheelguard (SYSTEM I)	* EAM0003J18A
Spring Case Deep Draw	* EAS2025D14A
Spring Centering Ring	* EAC0058D03A
Spring, VPI II	EAM003J21A
Standoff - Hex, M4 X 10mm	* 1-7861
Tension Spring - Sape	* 1-03267A
Terminal Lug-6.3mmx8mm,Pop Riv	* 2-23201
Threaded Shaft, 40mm	EAM0005D15A

Description	Part Number
Tool - PDQ Weight	00058839000
Transducer	EAA0260D59A
Transformer 500va	7-15601A
Tube-wheelguard Support, VPI II	* EAA0255J29A
Tubing - Flexible	* 8-00734A
Vibrator Ass'y-motorized	EAA0277D65A
Washer - Ext, Shakeproof 6mm	* 1-1548
Washer - Nylon Flat	* 1-11744A
Washer - Plain, M10.5 Din 125	* 1-11841
Washer, 8mm	* 1-17741
Washer, Flat 5/16	* 234123
Washer, Plain M8	* 1-10041
Washer-ext, Shakeproof, M3	* 1-1248
Washer-flat, M3 Din 125a	* 1-9541
Weight Tray - JBC System I	* EAC0053J07A
Weight Tray Mid Digital	* EAC0053J08A
Weldment Cabinet Md	* EAS2027G63A
Weldment-s1 Wheelguard Support (SYSTEM I)	* EAA0263G10A
Weldment-wheelguard, M1(SYSTEM II)	* EAS2021J15A
Wheelguard Support	* EAA0263G02A
Wheelguard Tube Ring Nut	* EAM0006G02A
Wing Nut (old)	* 8-02140A
Wing Nut (VPI System I) (Early)	00061072000

NOTE: PARTS LISTED WITH AN * OR OTHERWISE NOTED ARE CONSIDERED SPECIAL ORDER PARTS AND WILL NOT BE STOCKED, OR LISTED, IN THE EQUISERV PARTS SYSTEM UNTIL ORDERED BY A TECHNICIAN. WHEN ORDERING THESE PARTS PLEASE NOTE THAT THESE ARE GOOD PART NUMBERS BUT THE PARTS DEPARTMENT WILL HAVE TO SET THEM UP IN THE SYSTEM BEFORE YOU CAN ORDER ONE AND THEREFORE AN EXTENDED LEAD TIME MAY APPLY.

PARTS IN NUMERICAL ORDER

Part Number	Description
00058839000	Tool - PDQ Weight
00061072000	Wing Nut (VPI System I) (Early)
00061076000	Retainer Cup (VPI System I) (Early)
00061077000	Pressure Ring (VPI System I) (Early)
00061078000	Retainer Cup & Pressure Ring(VPI System I) (Early)
00110192000	Insert
00110194000	Cam
* 00111245000	Label - Caution, Electric
00112322000	Handle
* 1-01515A	Screw - HHMS 8M - 1.25 X 50mm
* 1-03267A	Tension Spring - Sape
* 1-06868A	Spring - Comp D145e, Din 2098
* 1-07039A	Nut - Tinnerman 1/4 - 20
* 1-07162A	Shim Ring - 28 X 40 X
* 1-10041	Washer, Plain M8
* 1-1115	Bolt-hex,5/16-18x3,Unc 2a, Tap
* 1-11233	Nut-hex, M3 Din 934
* 1-11633	Hex Nut
* 1-11633	Nut - Hex
* 1-11744A	Washer - Nylon Flat
* 1-11833	Nut, - M8 - 1.25
* 1-11833	Nut-Hex M 10 X 1 DIN 934
* 1-11841	Washer - Plain, M10.5 Din 125
* 1-1248	Washer-ext,Shakeproof,M3
* 1-13004	Screw Phillip Pan HD M 4 X 6
* 1-13077	Snap Ring
* 1-13377A	Circlip - 27 X 1.20
* 1-13609	Screw-shcs, M4-16 8.8
* 1-1401	Screw-HHC,3/8-16 X 1
* 1-1548	Washer - Ext,Shakeproof 6mm
* 1-15933A	Nut - Hex, M8 X 1.25 DIN 936
* 1-16309	Screw - Hex Hd Cap, M6 X 16 8.8
* 1-17403	Screw Hex Socket / Countersunk M 4 X 25
* 1-17559A	Nutsert - M6
* 1-17659A	Nutsert - M10
* 1-17709	Screw - Hshc M8 X 20mm
* 1-17741	Washer, 8mm
* 1-18209	Screw, Hex Head Socket - M8 X 45
* 1-18359A	Nutsert - M8
* 1-19903A	Screw Hex Socket / Countersunk M 4 X 65
* 1-2509	Screw-BHCS,1/4-20 X 5/8
* 1-2509	Screw - Bhcs,1/4-20 X 5/8
* 1-2676	Plug - Hole 2" Dia
* 1290404	Nut & L/Washer Assy 5/16 - 18
* 1-2967	Pretension Spring
* 1-30701	Screw Hex HD M 6 X 12
* 1-32701	Screw - HHMS 8M X 25mm
* 1-33201	Screw - Hhm M8 X 1.25 X 50mm
* 1-3624	Screw - Fhms,5x40mm,Self Tap
* 1-3724	Screw - Self Tap,5 X 10mm
* 1-3824	Screw - Self Tap,6 X 12mm
* 1-4034	Nut - Hex M 10 X 1 DIN 439
* 1-4577	Ring-snap,25 X 1.20
* 1-47810	Screw, Set, M8 X 8mm Flat Pt

Part Number	Description
* 1-5733A	Nut Hex 3/8
* 1611128	Disc, Spring
* 1-6498	Spring - Compression 5 X 63 X 120
* 1-6668	Compression Spring
* 1-6668	Compression Spring
* 1-6739	Nut - Tinnerman,1/4-20,J-type
* 1-7104	Screw
* 1-7558	Pop Rivet - 3/16"
* 1-7861	Standoff - Hex, M4 X 10mm
* 1-9541	Washer-flat, M3 Din 125a
2-01429A	Capacitor - Start, 10uf 400v
2-01529A	Capacitor - Start 20uf 400v
* 2-07557A	Sleeve - Compression,Oval
* 2-07657A	Clamping Device With Nut
2-16851A	Power Entry Module
* 2-17947A	Connector - 10 Pin, Wago 733-110
2-19851A	Fuse - time Delay,5.00a 5 X 20mm
* 2-23201	Terminal Lug-6.3mmx8mm,Pop Riv
* 234123	Washer, Flat 5/16
* 2-40848A	Connector-5 Pin, Wago 731-605
* 340774	Nut - Hex, 5/16 - 18
* 5-00838A	Bellow - Cover Tube
* 5-1145	Cable Tie - 8" X .11
* 6-00404A	2.700 Ft Rope-hemingway Dyneema,Type 40
7-15601A	Transformer 500va
* 7409019-020	Clamp jaws set
* 8-00734A	Tubing - Flexible
* 8-02140A	Wing Nut (old)
8-1144	Ball, Steel
* 8-1940	Pin-pushin, Nylon, .165 X 1.062
* 8-23562A	Label - Warning
* 8-23662A	Label - Safety
* 8-23762A	Label Earth Symbol
8-3531	Multirib Belt 5 PJ 711 Din 7867
* 8-634-01	Protective Pipe For Cables (Old Style)
* 8-7216	Plug - Hole,16mm
* 977757	Ring-snap,25 X 1.20
* EAA0247G21A	Caliper-Rim Width
EAA0255J18A	Membrane - JBC System I & II
EAA0255J23A	Electronic Unit Y2k Bal
* EAA0255J29A	Tube-wheelguard Support, VPI II
* EAA0255J33A	Adapter Assy'
EAA0260D09A	Encoder PCB
EAA0260D56A	Brake lever A cpl.
EAA0260D57A	Brake lever B cpl.
EAA0260D58A	Cable - Brake, S1
EAA0260D59A	Transducer
* EAA0263G02A	Wheelguard Support
EAA0263G07A	Brake Pedal Ass'y
* EAA0263G10A	Weldment-s1 Wheelguard Support (SYSTEM I)
EAA0263G66A	Quicknut W/ Handles, 40 mm (VPI System II)
EAA0263G79A	Quick Nut Kit
EAA0266D20A	Rotative Transducer - Assy
EAA0266D29A	Motor, AC 120w 1 Ph 220-240v - 50/60 Hz
EAA0277D65A	Vibrator Ass'y-motorized
EAC0053J03A	Arm-sape

Part Number	Description
EAC0053J06A	Adjuster - Arm, Sape
* EAC0053J07A	Weight Tray - JBC System I
* EAC0053J08A	Weight Tray Mid Digital
* EAC0053J09A	Cover-wheelguard, Y2k
* EAC0053J11A	Housing-display, JBC System I & II
* EAC0053J16A	Plate-switch Mounting
* EAC0058D03A	Spring Centering Ring
EAC0058D06A	Rope - Reel 290mm
EAC0058D07A	Cup-Pressure,Haweka
EAC0058D08A	Disk Pressure
EAC0058D09A	Ejector
EAC0058D11A	Disk - Touching
EAC0058D12A	Cog Wheel - 56 Tooth
EAC0058D13A	Cog Wheel-28 Tooth
EAC0058D15A	Rubber Ring
* EAC0060G02A	Flange - Cover,Access
* EAC0060G03A	Bushing, Wheelguard Tube
* EAL0341J07A	Label - Warning, Disconnect Power
* EAL0341J37A	Label - fuse 5 AMP
* EAL0345D01A	Measure Tape - Sape
EAM0003J05A	Cone-Small
EAM0003J06A	Cone-Small
EAM0003J07A	Cone-Large
EAM0003J08A	Cone-Truck, 29 Deg
* EAM0003J18A	Spring - Extension Wheelguard (SYSTEM I)
* EAM0005D07A	Setscrew - Hex Socket M 10 X 1
EAM0005D08A	Motor Pulley
* EAM0005D09A	Motor Distance bolt
* EAM0005D12A	Drive Wheel
EAM0005D15A	Threaded Shaft, 40mm
* EAM0005D18A	Spacer
* EAM0005D18A	Spacer
* EAM0005D35A	Guiding Reel
EAM0005D36A	Rod- SAPE (VPI I)
EAM0005D37A	Rod - M1(VPI II)
* EAM0005D38A	Bushing 1
* EAM0005D39A	Bushing 2
EAM0005D40A	Calibration Weight
* EAM0006G01A	Hook - Accessory Storage
* EAM0006G02A	Wheelguard Tube Ring Nut
EAM003J21A	Spring, VPI II
EAP0201D00C	PCB Ass'y - Processor
EAP0201D10B	PCB Ass'y - Power Interface
EAP0207P00A	Pcb Assy - Display, Jbc
* EAS0207G38A	Plate - Wheelguard Cover
* EAS2021J06A	Bracket-top Adjuster, Display
* EAS2021J12A	Bracket Wldmt-plate, Display
* EAS2021J15A	Weldment-wheelguard, M1(SYSTEM II)
* EAS2021J16A	Display Wldmt-tower, S1, M1
* EAS2021J24A	Sheet - Fireshield
* EAS2021J29A	Backing Plate
* EAS2021J32A	Angle - 2d Sape
* EAS2021J36A	Mounting Brkt 2D SAPE
* EAS2021J43A	Backpack Base
* EAS2021J44A	Backpack Top
* EAS2021J63A	Clamp,Tower

Part Number	Description
* EAS2021J64A	Plate, Tube Stop
* EAS2025D14A	Spring Case Deep Draw
* EAS2027G00A	Cabinet-balancer, S1a
* EAS2027G18A	Brake Pedal Support Bracket
* EAS2027G31A	Chamfered Brake Pedal
* EAS2027G36A	Sheet - Support, Tube
* EAS2027G63A	Weldment Cabinet Md
* EAW0233J04A	Display Cable - JBC
* EAW0233J05A	Cable - IEC Module Power Interfa
* EAW0233J06A	Cable - IEC, Jumper
EAW0233J07A	Harness - Wiring, Transformer
EAW0233J08A	Microswitch
EAW0239D00A	Ribbon Cable Vibratory
EAX0039J01A	Cord - Power, 230v
* ST0027000	Cover
* ST0027005	Spacer
* ST7022499	C - Clip
* ST7205389	Screw, Handle
* ST7417071	Screw
* ZEEWB503A9	Lit Pack - ZEEWB503A9
* ZEEWB504A9	Lit Pack - ZEEWB504A9

NOTE: PARTS LISTED WITH AN * OR OTHERWISE NOTED ARE CONSIDERED SPECIAL ORDER PARTS AND WILL NOT BE STOCKED, OR LISTED, IN THE EQUISERV PARTS SYSTEM UNTIL ORDERED BY A TECHNICIAN. WHEN ORDERING THESE PARTS PLEASE NOTE THAT THESE ARE GOOD PART NUMBERS BUT THE PARTS DEPARTMENT WILL HAVE TO SET THEM UP IN THE SYSTEM BEFORE YOU CAN ORDER ONE AND THEREFORE AN EXTENDED LEAD TIME MAY APPLY.

**USA**

John Bean
309 Exchange Avenue
Conway, Arkansas 72032
Tel.: (800) 362-8326 or (501) 450-1500
Fax: (501) 450-1585

CANADA

John Bean
6500 Millcreek Drive
Mississauga, Ontario
Canada L5N 2W6
Tel: (905) 814-0114
Fax: (905) 814-0110

FRANCE

John Bean
Snap-On Equipment France
Z.A. Du Vert Galant
15, rue de la Guivernone
BP 7175
95310 Saint Ouen L'Aumone
Tel: (33) 1-3448-5878
Fax: (33) 1-3448-5879

JBC GERMANY

Geschaeftsbereich der Snap-on Equipment GmbH
Werner-von-Siemens-Str. 2
D-63419 Pfungstadt
Deutschland
Tel: +49 (0) 6157 12 600
Fax: +49 (0) 6157 12 601
Website: www.johnbean.de

UNITED KINGDOM

Snap-On Equipment Ltd.
John Bean Equipment Group
Oldmedow Road
Kings Lynn
Norfolk
PE30 4JW

LATIN AMERICA

Snap-on Tools International, Ltd.
2801 80th Street
Kenosha, WI 53143
Tel: (262) 656-5003
Fax: (414) 656-1403

Notice: The information contained in this document is subject to change without notice. **John Bean** makes no warranty with regard to this material. **John Bean** shall not be liable for errors contained herein or for incidental consequential damages in connection with furnishings, performance, or use of this material.

This document contains proprietary information which is protected by copyright and patents. All rights are reserved. No part of this document may be photocopied, reproduced, or translated without prior written consent of **John Bean**.



is a registered trademark of Snap-on Technologies