

# *Service Parts Manual*

---



EEWB526B

All information contained or disclosed in this document is considered confidential and proprietary by Snap-on Tools Company. All manufacturing, use, reproduction, and sales rights are reserved by Snap-on Tools Company and the information contained herein shall not be used in whole or in part without the express written consent of Snap-on Tools Company.

# Table of Contents

Cabinet Assembly .....	2
Weight Tray Assembly .....	6
Foot Pedal Assembly .....	7
Upper Display Assembly .....	8
Electronic Box Assembly .....	10
Hood Guard Pivot .....	12
Sonic Assembly .....	14
SAPE Assembly .....	16

# 1572b

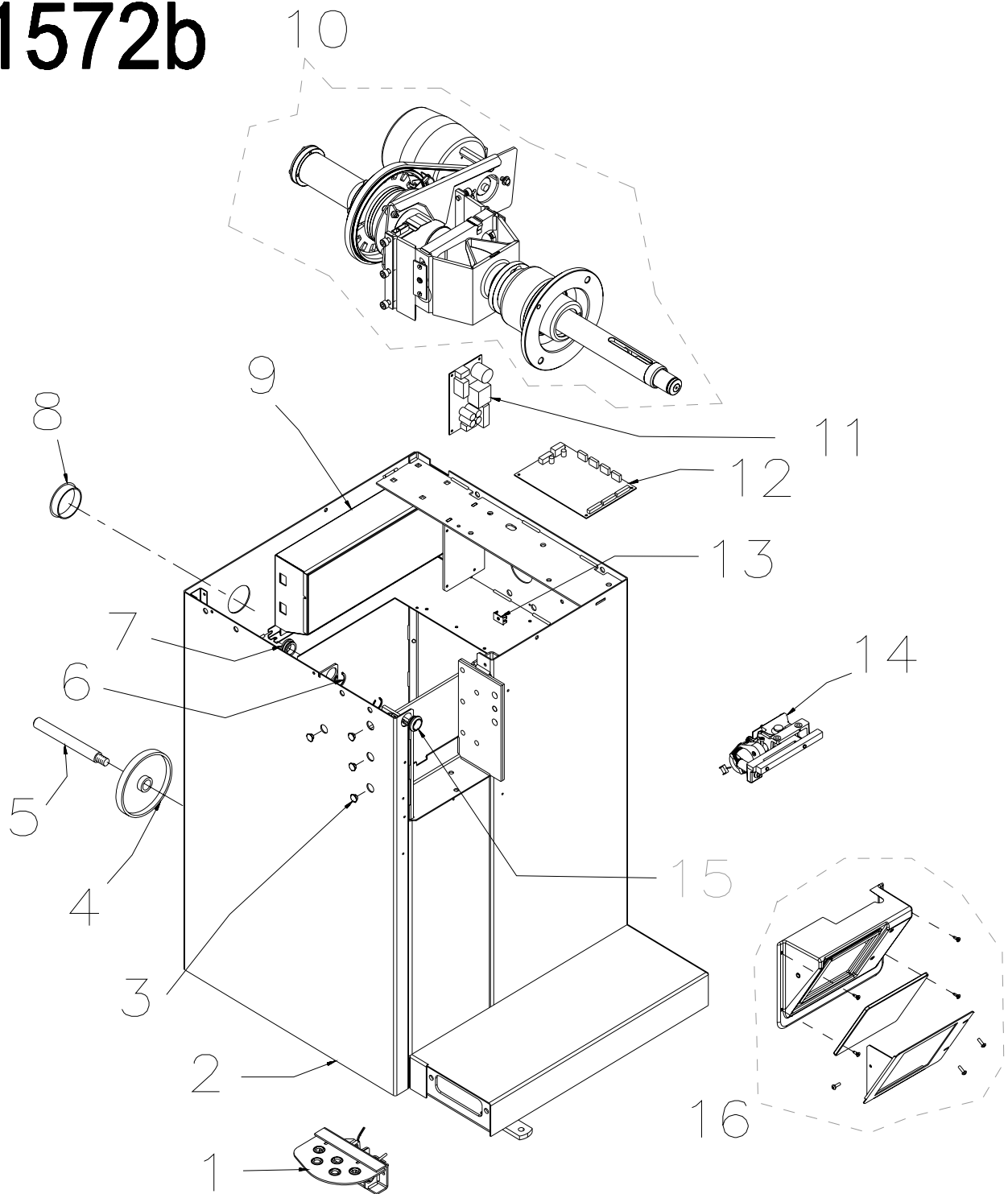

**1572b: M1 cabinet assembly**

<b>No.</b>	<b>Snap-on P/N.</b>	<b>Description</b>	<b>Qty</b>	<b>Note</b>
1	EAA0332G26A	Brake pedal assembly	1	
2	EAS2092G01A	M1 cabinet	1	RAL 3000
3	8-7216	Plug	4	
4	EAC0060G02A	Flange cover, accessory	4	
5	EAM0006G01A	Hook accessory storage	4	
6	1-13877A	Ring snap	2	25 x 1,2
7	EAM0005D39A	Bushing inside sape	1	
8	1-1276	Dome hole plug	1	
9	EAA0255J75A	Digital box	1	
10	EAA0344G06A	Vibratory system "P" optima	1	
11	2-48066A	12V switching power supply	1	
12	EAP0204G50F	Programmed camera processor board	1	
13	2-23201	Flat plug grounding	3	
14	EAA0307G13A	Inside scanner assembled unit	1	
15	EAM0005D38A	Bushing outside sape	1	
16	EAA0307G14A	Inside laser protection complete	1	
	EAM00066G67A	Glass - Bottom		
	EAS2067G76A	Bracket Bottom Glass		
	1-16309	Screw SHCS M6 X 16mm		
	1-17559A	Nutsert		

**VIBRATORY AND CONES**

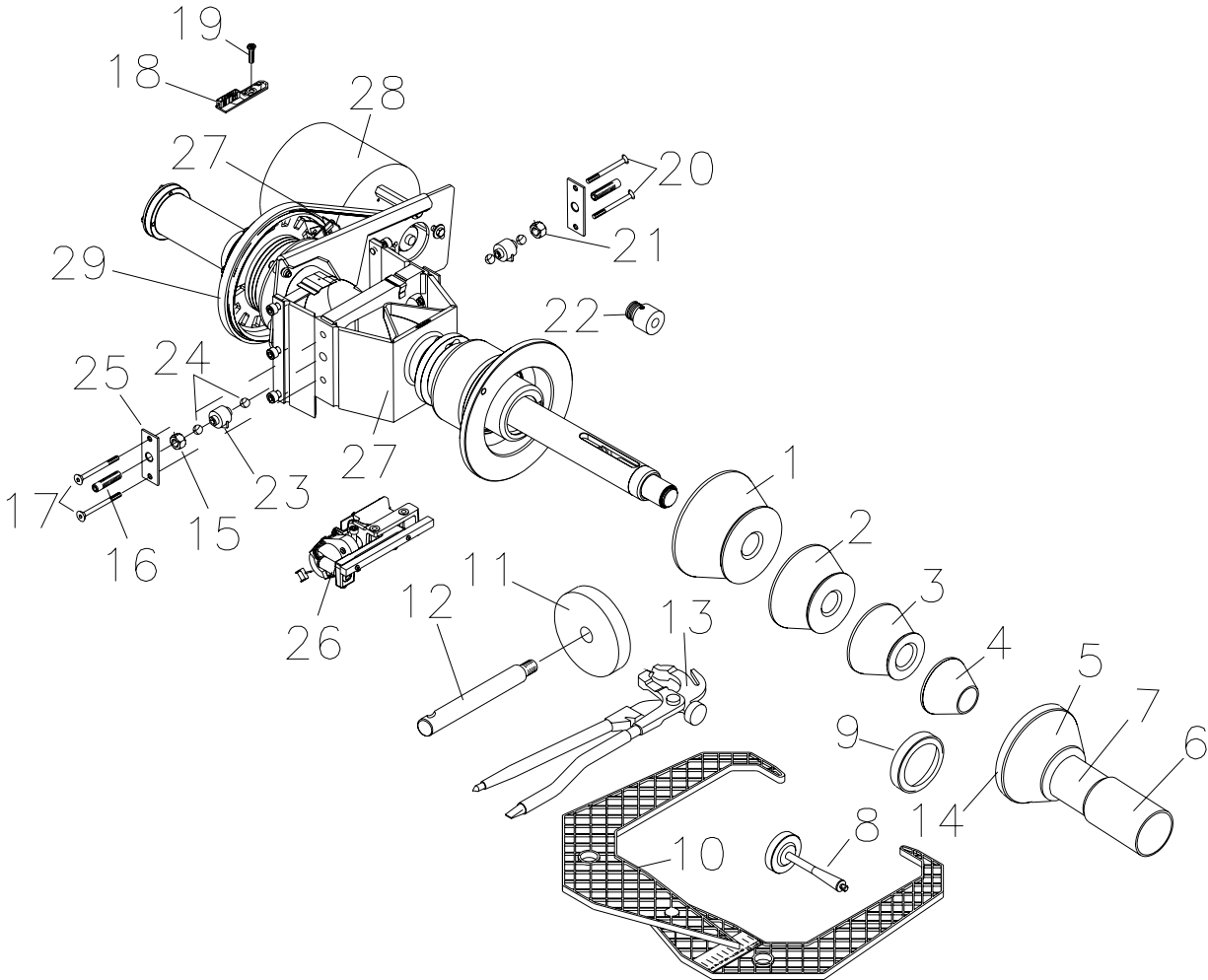

## VIBRATORY AND CONES

<u>Ref</u>	<u>Qty</u>	<u>Part Number</u>	<u>Description</u>
1	1	EAM0003J08A	Cone-Truck, 29 Deg
2	1	EAM0003J07A	Cone-Large
3	1	EAM0003J06A	Cone-Small
4	1	EAM0003J05A	Cone-Small
		<b>EAA0307G54A</b>	<b>Power Clamp Nut Assembly</b>
5	1	EAC0058D07A	Cup - Large Pressure
6	1	EAM0005D54A	Plastic Sleeve
7	1	EAA0283D53A	Power Clamp Nut
8	1	EAM0005D40A	Calibration Weight
9	1	EAC0058D08A	Small Pressure Disk
10	1	EAA0247G21A	Caliper-Rim Width
11	4	EAC0060G02A	Flange - Cover,Access
12	4	EAM0006G01A	Hook - Accessory Storage
13	1	00058839000	Tool - PDQ Weight
14	1	EAC0058D15A	Rubber Ring
15	1	1-11833	Nut-Hex M 10 X 1 DIN 934
16	2	EAM0005D07A	Setscrew - Hex Socket M 10 X 1
17	2	1-19903A	Screw Hex Socket / Countersunk M 4 X 65
18	1	EAA0344G00A	Encoder PCB
19	1	1-13004	Screw Phillip Pan HD M 4 X 6
20	2	1-17403	Screw Hex Socket / Countersunk M 4 X 25
21	1	1-4034	Nut - Hex M 10 X 1 DIN 439
22	1	EAM0005D08A	Pulley Small
23	1	EAA0260D59A	Transducer
24	4	8-1144	Ball, Steel
25	2	1-2967	Pretension Spring
26	1	EAA0307G13A	Inside Scanner
27	1	EAA0344G06A	Vibrator Ass'y-motorized
*	1	EAP0201D20A	Power Clamp Encoder
28	1	EAA0266D29A	Motor 230V/50-60HZ
29	1	8-3531	Multirib Belt 5 PJ 711 Din 7867
*	1	EAW0239D00A	Ribbon Cable Vibratory

1108b

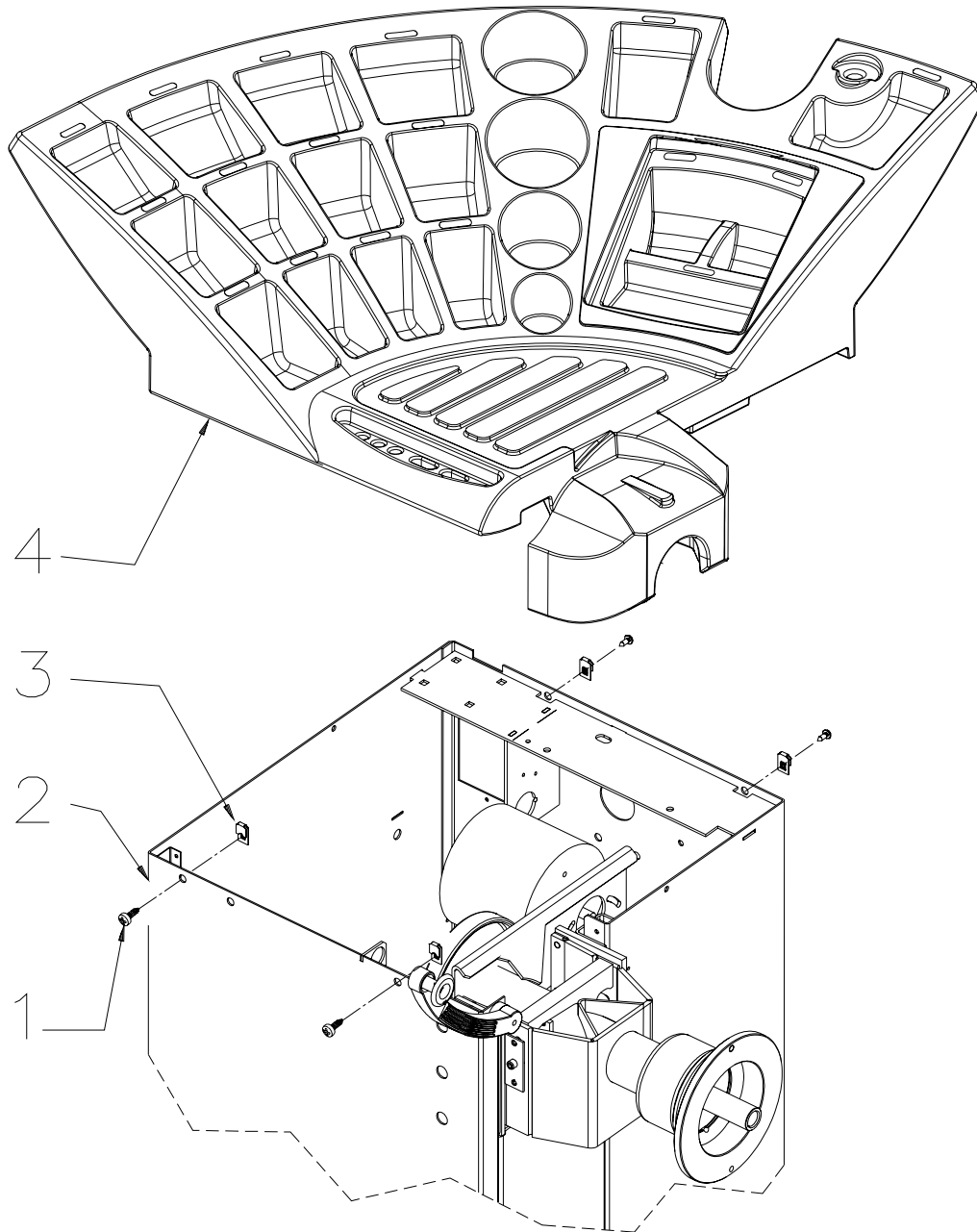

1108b: Weight Tray Assembly

No.	Snap-on P/N.	Description	Qty
1	1-30706A	1/4 - 20 Screw	2
	1-39809A	1/4 - 20 Screw	2
2	1-13241	Washer	4
3	1-07439A	Retainer, Self Thr. Screw	4
4	EAC0054P11A	Weight-Tray	1
6			



1561

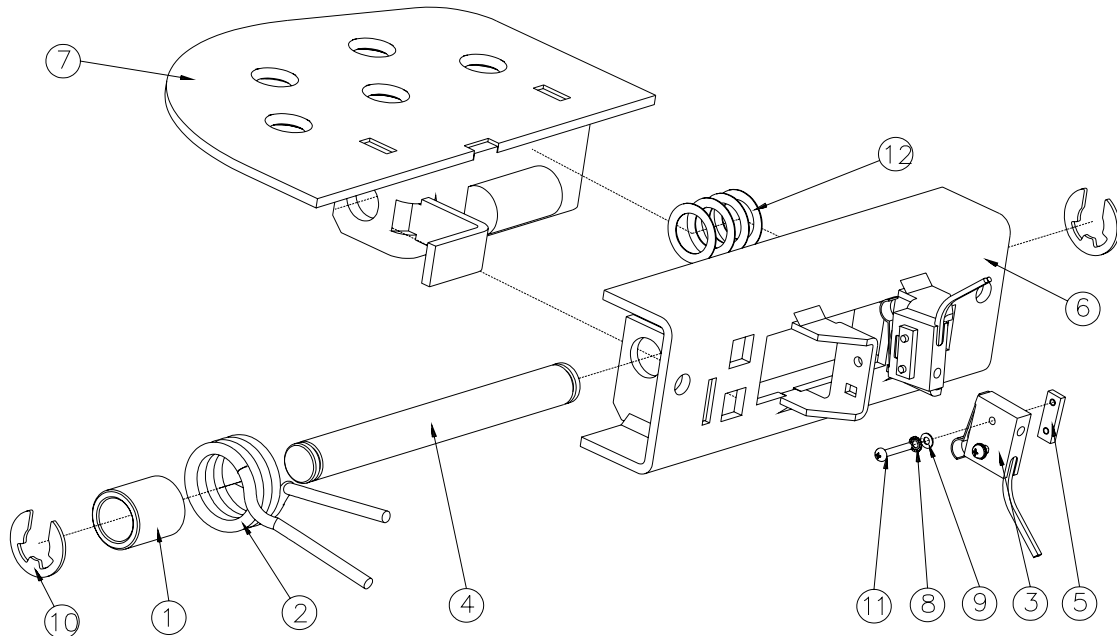

04/2006

Fig. 1561: Pedal assembly

EAA0332G26A	Brake pedal assy		
1	EAM0051G96A	Bushing cent. spring br. pedal	
2	EAM0048G78A	Spring, pedal switch	
3	2-07661A	Microswitch	
4	EAM0046G39A	Pedal pin	
5	EAM0046G40A	Threaded block	
6	EAS2090G15A	Brake pedal support	
7	EAS2089G80A	Welded pedal	
8	1-1048	Washer external shakeproof	D. 2mm
9	1-9341	Washer	A 2.2-A2J-DIN 125A
10	1-18477A	Retaining ring	10x1.2mmA2R DIN6799
11	1-9804	Screw, phillips head	M2x12
12	1-25241A	Shim ring	D12.2x18x0.3mm DIN988

1573b

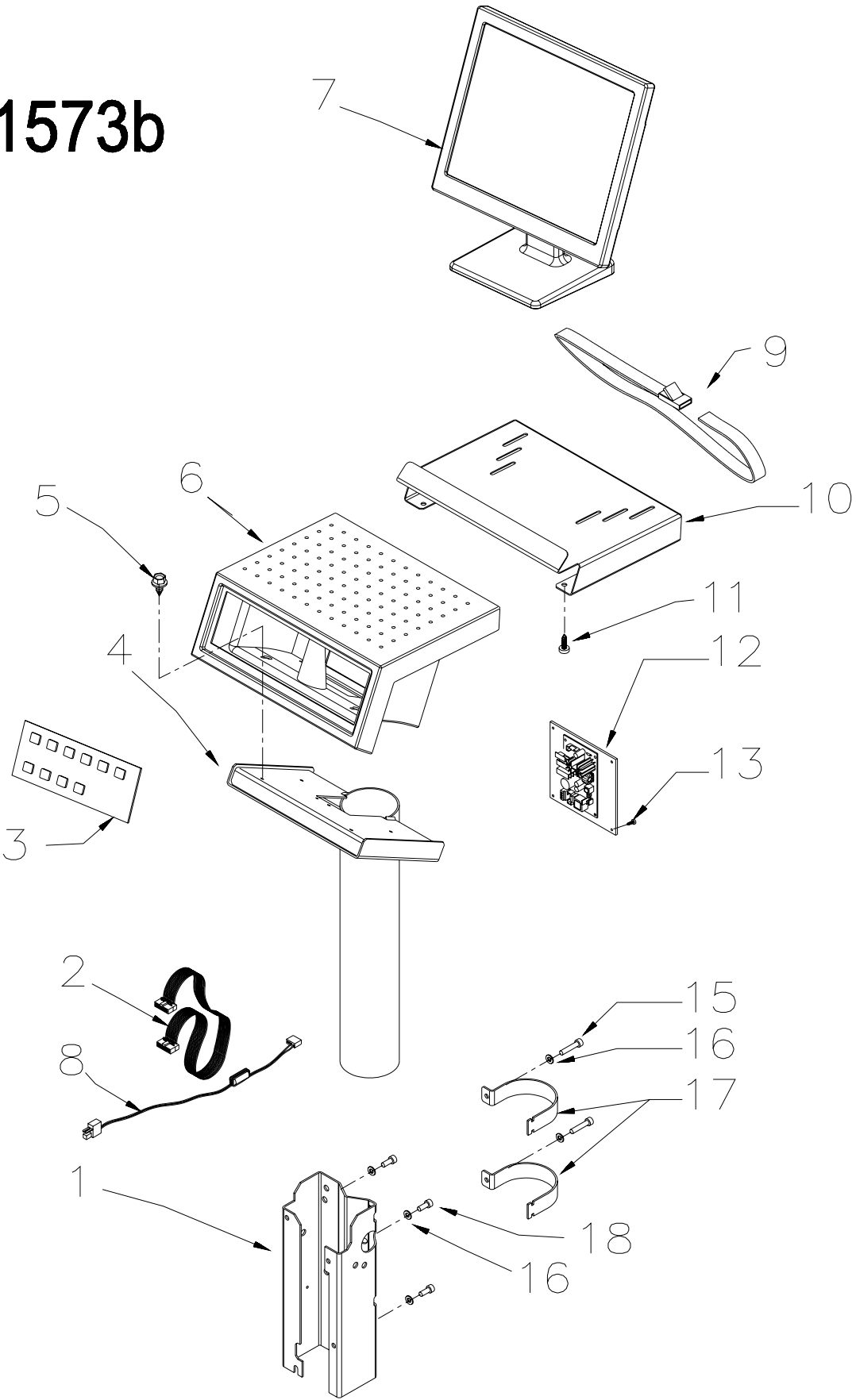

**1573b: User interface assembly**

<b>No.</b>	<b>Snap-on P/N.</b>	<b>Description</b>	<b>Qty</b>	<b>Note</b>
1	EAS2092G00A 1-18359A	Tower Spacer, Assembled Nutsert M8 X 1.25	1	
2	EAW0233J18A	Wiring Harness	1	
3	EAA0307G67A	keyboard	1	
4	EAA0313D88A	Column, Monitor Support	1	
5	1-11626A	Self tapping screw	4	M6 x 12
6	EAC0058D88A	Display housing	1	
7	3-01908A	LCD monitor	1	15"
8	EAW0240G48A	Power Cable Embedded PC	1	
9	5-12926A	Monitor locking bend	1	
10	EAS2058D94A	Support for monitor	1	
11	1-22323A	Screw	4	5,5 x 16
12	3-01509A EAS2086G67A	Embedded PC Assembled (Without CF) Support Plate	1	
13	1-20423	Screw	4	4,2 x 13
15	1-18209A	Screw	2	M8 x 45
16	1-10041	Washer	6	Ø 8,4
17	EAS2067G29A	Monitor tower clamping hook	2	
18	1-17709	Screw	4	M8 x 20

# 1196b

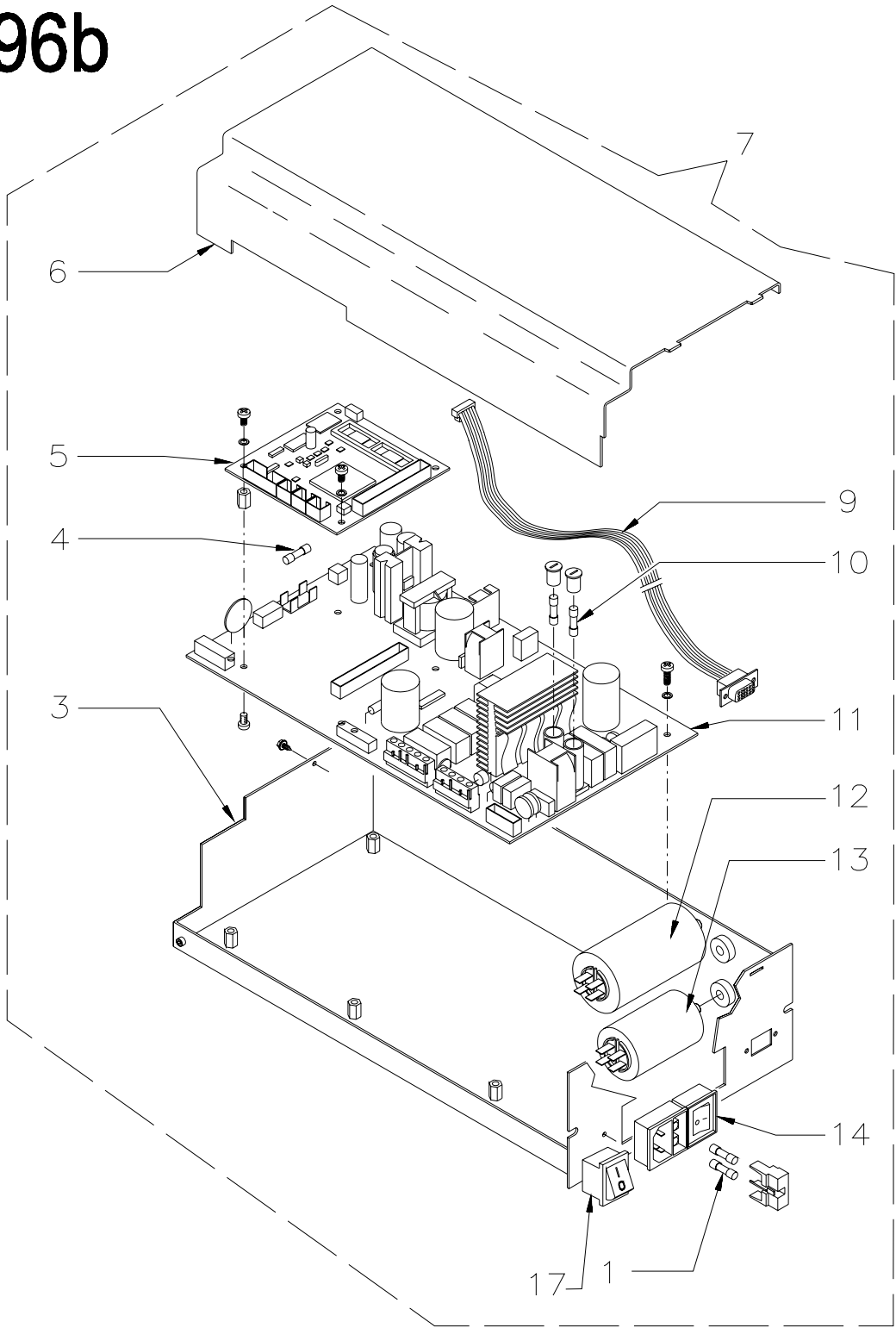

**1196b1: Electronic unit**

<b>No.</b>	<b>Snap-on P/N.</b>	<b>Description</b>	<b>Qty</b>	<b>Note</b>
1	2-21251A	Fuse	2	6.3A(T) Iec 60127
3	EAS2021J31A	Bottom of digital box	1	
4	2-16951A	Fuse	1	1.25A (5x20mm)
5	EAP0201D10A	Controller board	1	
6	EAS2021J30A	Cover of digital box	1	
7	EAA0255J75A	Electronic unit assembly	1	
10	2-15351A	Fuse	2	3,2A - 250V
11	EAP0201D10A	Power Interface Board	1	
12	2-01529A	Capacitor	1	
13	2-01429A	Capacitor	1	
14	2-16851A	Power entry module	1	
	EAW0233J06A	Cable - IEC Jumper		
	EAW0233J05A	Cable - IEC Module		
	EAL0349G44A	Decal - Fuses		
	EAW0239D05A	Cable - Grounding		
	8-23562A	Label - Warning		
	EAL0341J07A	Label - Warning Disconnect		
	8-23762A	Label - Earth Symbol		
	111245	Label - Caution		

# Hood Guard Pivot

# 1574

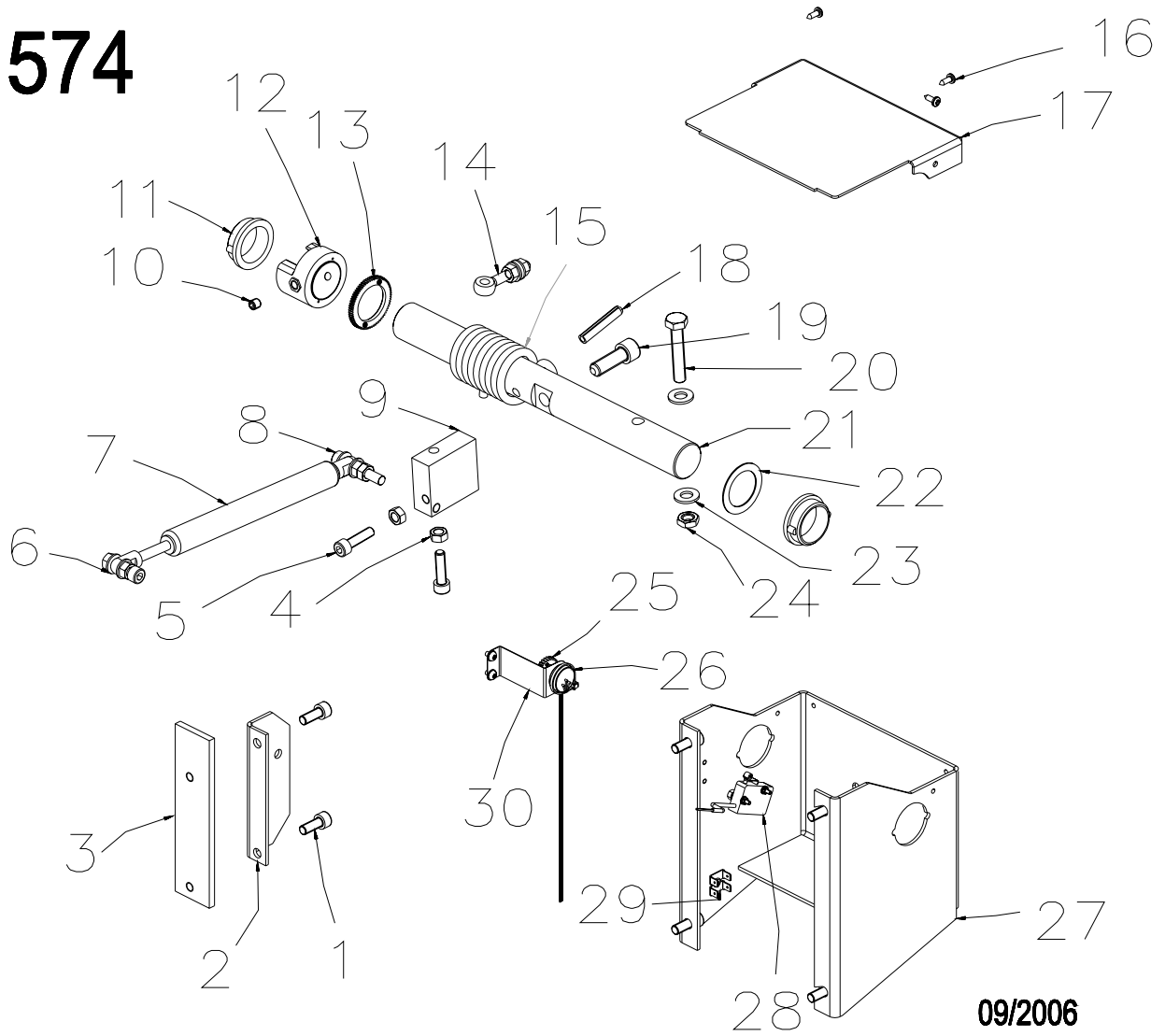

09/2006

**1574b: Wheel guard support**

No.	Snap-on P/N.	Description	Qty	Note
1	1-17709	Screw	6	M8 x 20
2	EAS2081J66A	Brake attachment angular	1	
3	EAM0052G48A	Anchor plate	1	
4	1-11733	Nut	8	M8
5	1-17909	Screw	3	M8 x 30
6	1-10041	Washer	10	Ø 8,4
7	1-05369A	Hydraulic brake	1	
8	1-18209	Screw	1	M8 x 45
9	EAM0052G47A	Wheelguard stop	1	
10	1-49010A	Screw	1	M8 x 8
11	EAC0058D36A	Bushing	2	Ø 32
12	EAC0058D38A	Switch ring	1	
13	EAC0087G28A	Cog wheel	1	Z=56
14	1-01530	Eye Bolt	1	M8 x 50
15	1-04267A	Wheelguard spring	1	
16	1-17923	Screw	3	4,2 x 13
17	EAS2081J67A	Cover for wheelguard support	1	RAL 9005
18	1-12452	Pins-straight slotted	1	Ø 8 x 45
19	1-20409	Screw	1	M12 x 45
20	1-35001	Screw	1	M10 x 55
21	EAM0048G32A	Standardized Wheel Guard Shaf	1	M1
22	1-22441A	Shim ring	1	32 x 45 x 1
23	1-10141	Washer	2	Ø 10,5
24	1-18733A	Nut	1	M10
25	EAC0058D13A	Cog wheel	1	Z=28
26	EAW0240G71A	Wheel guard Potentiometer	1	
27	EAA0346J04A	Wheelguard Support	1	RAL 9005
28	EAW0233J08A	Micro switch	1	
29	2-23201	Flat plug grounding	1	
30	EAS2092G04A	Transducer support	1	
	EAC0053J16A	Plate - Microswitch		
	2-076557A	Clamping Device W/nut		

# Sonic Assembly

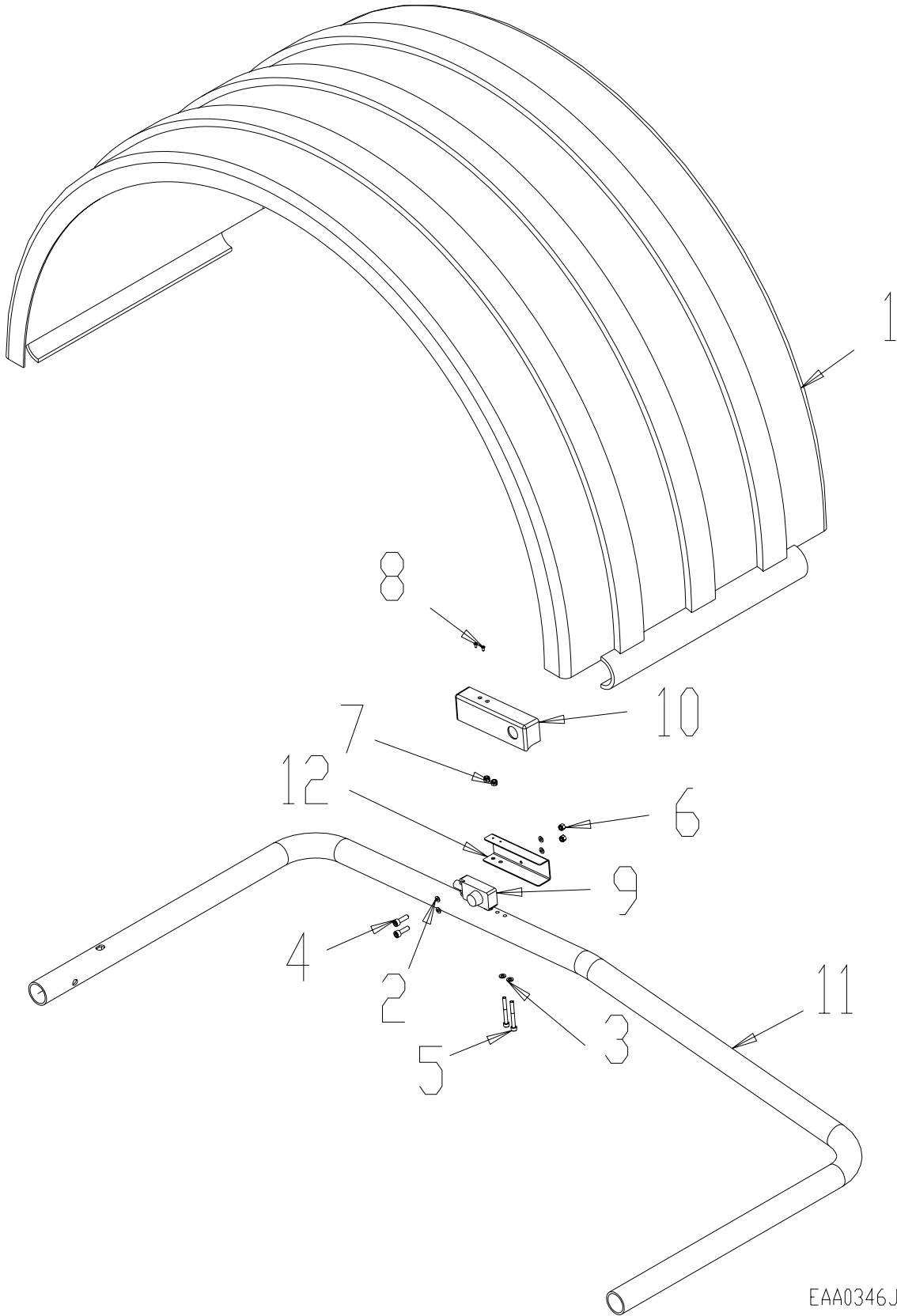

EAA0346J01A



**EAA0346J01A: Wheel guard support**

<b>No.</b>	<b>Snap-on P/N.</b>	<b>Description</b>	<b>Qty</b>
1	2800051	WG-COVER G2600/2800	1
2	1-9641	WASHER PLAIN M4	4
3	1-9741	WASHER-5MM PLAIN	2
4	1-13709	SCREW-SHCS M4 X 20MM ZINC	2
5	1-15609	SCREW-SOC HD CAP M5 X 45	2
6	1-01737A	NUT-ESNA M4	2
7	1-20833A	NUT-M5 SELF LOCKING	2
8	1-22823A	SCREW-FLH 2.9 X 6.5 PHIL TAP	2
9	2-48166A	SENSOR-ULTRASONIC BFH	1
10	EAC0087G29A	COVER-ULTRASONIC SENSOR BFH	1
11	EAM0050J02A	TUBE-BFH 800 WHEEL GUARD	1
12	EAS2081J69A	SUPPORT-SONAR BFH	1

1570

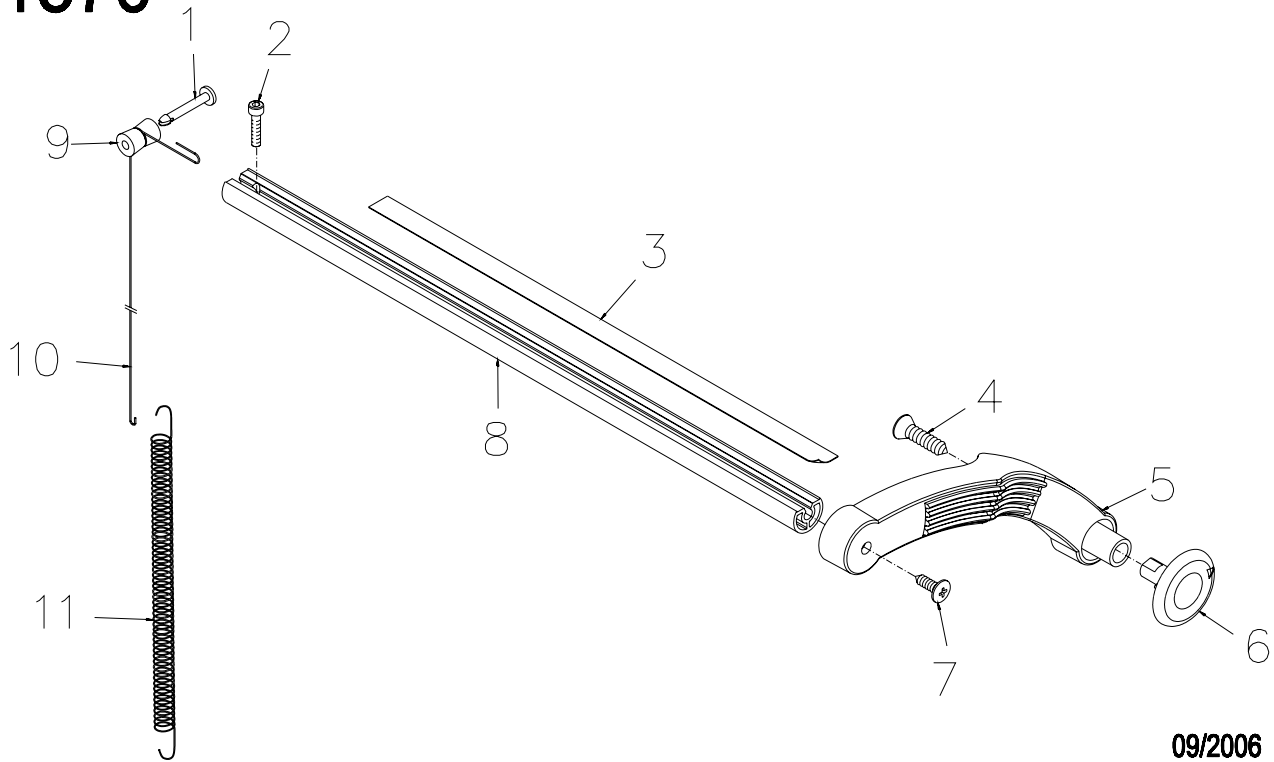

09/2006

**1570: M1 manual sape**

No.	Snap-on P/N.	Description	Qty	Note
1	8-1940	Pin pushing nylon	1	
2	1-13609A	Screw	1	M4 x 16
3	EAL0349G31A	Distance Scale Decal	1	
4	1-3624	Screw	1	PP82 5 x 40
5	EAC0054P01A	Arm axcel caliper	1	
6	EAC0058D11A	Touching disk	1	
7	1-3824	Screw	1	M6 x 12
8	EAM0005D37A	Gauge Rod	1	
9	EAM0005D35A	Guiding Reel Sape	1	
10	6-00404A	Rope hemingway	1	1 mt
11	1-03267A	Tension spring	1	



**Notice:** The information contained in this document is subject to change without notice. **Snapon Equipment** makes no warranty with regard to this material. **Snapon Equipment** shall not be liable for errors contained herein or for incidental consequential damages in connection with furnishings, performance, or use of this material.

This document contains proprietary information which is protected by copyright and patents. All rights are reserved. No part of this document may be photocopied, reproduced, or translated without prior written consent of **Snapon Equipment**.