

**VPI SYSTEM IV
COMPUTER WHEEL BALANCER**



FOR:

PASSENGER CAR/LIGHT TRUCK WHEELS



OPERATION INSTRUCTIONS

ZEEWB516B

Blank page

SAFETY INFORMATION

**For your safety, read this manual thoroughly
before operating the SYSTEM IV Wheel Balancer**

The JBC SYSTEM IV Wheel Balancer is intended for use by properly trained automotive technicians. The safety messages presented in this section and throughout the manual are reminders to the operator to exercise extreme caution when servicing tires with these products.

There are many variations in procedures, techniques, tools, and parts for balancing tires, as well as the skill of the individual doing the work. Because of the vast number of wheel and tire applications and potential uses of the product, the manufacturer cannot possibly anticipate or provide advice or safety messages to cover every situation. It is the automotive technician's responsibility to be knowledgeable of the wheels and tires being serviced. It is essential to use proper service methods in an appropriate and acceptable manner that does not endanger your safety, the safety of others in the work area or the equipment or vehicle being serviced.

It is assumed that, prior to using the SYSTEM IV Wheel Balancer, the operator has a thorough understanding of the wheels and tires being serviced. In addition, it is assumed he has a thorough knowledge of the operation and safety features of the rack, lift, or floor jack being utilized, and has the proper hand and power tools necessary to service the vehicle in a safe manner.

Before using the SYSTEM IV Wheel Balancer, always refer to and follow the safety messages and service procedures provided by the manufacturers of the equipment being used and the vehicle being serviced.



IMPORTANT !! SAVE THESE INSTRUCTIONS -- DO NOT DISCARD !!

IMPORTANT SAFETY INSTRUCTIONS

When using this equipment, basic safety precautions should always be followed, including the following:

1. Read all instructions.
2. Do not operate equipment with a damaged power cord or if the equipment has been damaged - until it has been examined by a qualified authorized service technician.
3. If an extension cord is used, a cord with a current rating equal to or more than that of the machine should be used. Cords rated for less current than the equipment may overheat. Care should be taken to arrange the cord so that it will not be tripped over or pulled.
4. Always unplug equipment from electrical outlet when not in use. Never use the cord to pull the plug from the outlet. Grasp plug and pull to disconnect.
5. To reduce the risk of fire, do not operate equipment in the vicinity of open containers of flammable liquids (gasoline).
6. Keep hair, loose fitting clothing, fingers and all parts of the body away from moving parts.
7. Adequate ventilation should be provided when working on operating internal combustion engines.
8. To reduce the risk of electric shock, do not use on wet surfaces or expose to rain.
9. Do not hammer on or hit any part of the control panel with weight pliers.
10. Do not allow unauthorized personnel to operate the equipment.
11. Do not disable the hood safety interlock system or bypass the intended operation.
12. Use only as described in this manual. Use only manufacturer's recommended attachments.
13. Always make sure the power clamp is secure before spinning the shaft.
14. ALWAYS WEAR SAFETY GLASSES. Everyday eyeglasses only have impact resistant lenses, they are NOT safety glasses.
15. Balancer is for indoor use only.

SAVE THESE INSTRUCTIONS

Table ofContents

SAFETY INFORMATION	0
1.0 INTRODUCTION	1
1.1 SAFETY NOTICE	1
1.2 BALANCER APPLICATION	1
1.3 VPI SYSTEM IV SPECIFICATIONS	2
1.4 FEATURES	2
1.5 STANDARD ACCESSORIES	3
1.6 DIMENSIONS OF THE MACHINE	3
1.7 REQUIRED INSTALLATION AREA	4
2.0 INSTALLATION INSTRUCTIONS	4
2.1 COMPONENT INSTALLATION	4
2.2 HOOD GUARD INSTALLATION	5
2.3 WIDTH SAPE ARM INSTALLATION	5
2.4 ELECTRIC INSTALLATION	5
2.5 INSTALLATION OF THE MONITOR	5
2.6 USER SETUP	6
3.0 PHYSICAL LAYOUT	8
3.2 MENU KEYS	9
3.2.2 MAIN MENU FUNCTIONS	10
3.2.3 BALANCING	10
3.2.8 FUNCTION (SETUP)	12
4.0 HELP INFORMATION	13
5.0 POWER CLAMP OPTION	14
6.0 OPERATION OF THE BALANCER	15
6.1 CHECK LIST - INSPECTION	15
6.2 BALANCE SCREEN DESCRIPTION	16
6.2.1 WHEEL MOUNTING	17
6.2.2 STANDARD WHEELS (BACK CONE MOUNT)	17
6.2.3 CENTERING LIGHT-TRUCK WHEELS	17
6.4 SPINNING THE WHEEL	19
6.5 SELECTING THE WEIGHT PLACEMENT	19
6.6 CORRECTION OF THE IMBALANCE	19
6.7 VERIFICATION OF THE RESULTS	20
6.8 VIBRATION PROBLEMS	21
7.0 SPOKE BALANCING MODE	21
8.0 OPTIMISATION PROCEDURES	22
9.0 WEIGHT MISER	27
10.0 USER CALIBRATION	29
11.0 EXPLANATION OF PROGRAM CODES	30
12.0 MAINTENANCE	31
13.0 TROUBLE SHOOTING	31

1.0 INTRODUCTION

Congratulations on purchasing the **VPI System IV** computer wheel balancer. This wheel balancer is designed for ease of operation, accuracy, reliability and speed. With proper maintenance and care your wheel balancer will provide many years of trouble-free operation.

Instructions on use, maintenance and operational requirements of the machine are covered in this manual.

1.1 SAFETY NOTICE

This manual is a part of the balancer product.

Read carefully all warnings and instructions of this manual since they provide important information concerning safety and maintenance.

1.2 BALANCER APPLICATION

*The John Bean wheel balancer model **VPI System IV** is intended to be used as a device to balance car, and light truck wheels within the following range:*

<i>Maximum tire diameter</i>	<i>:</i>	<i>44" (1117mm)</i>
<i>Maximum wheel diameter</i>	<i>:</i>	<i>30" (762mm)</i>
<i>Maximum wheel width</i>	<i>:</i>	<i>15" (381mm)</i>
<i>Maximum wheel weight</i>	<i>:</i>	<i>154 lbs (70 kg)</i>

This device is to be only used in the application for which it is specifically designed. Any other use shall be considered as improper and thus not reasonable.

The manufacturer shall not be considered liable for possible damages caused by improper, wrong or non reasonable use.

This unit uses an open source Linux operating system for its user interface. This open source code is available for the cost of shipping and handling to owners of the SYSTEM IV Wheel Balancer. Requests must be made to the attention of balancer product management at the Conway AR address listed on the back of this manual. Please include the owners name, address and unit serial number with all requests.

**STORE THIS MANUAL IN A SAFE PLACE FOR FUTURE REFERENCE.
READ THIS MANUAL THOROUGHLY BEFORE USING THE MACHINE.**

1.3 VPI SYSTEM IV SPECIFICATIONS

Computerized digital wheel balancer for car, light truck wheels.

Weight Imbalance Accuracy	.05 oz / 1 gram
Weight Placement Resolution	± .7 degrees
Weight Imbalance Resolution:	
Roundoff Mode	.25 oz / 5 grams
Non-Roundoff Mode	.05 oz / 1 gram
Max. Shaft Weight Capacity	154 lbs / 70 kg
Max. Tire Diameter	44" / 1117 mm
Rim Width Capacity	3.0"-20" / 76 mm - 508 mm
Rim Diameter Capacity	8"-30" / 152 mm-762 mm
Balancing Cycle Time.	7 seconds or less
Shaft Speed at calculation	>200 RPM
Electrical	230vac, 1ph, 50-60Hz, 3.2A
Required Work Area	62" x 67" (1574 x1702 mm)
Shipping Weight, complete	430 lbs
Shipping Dimensions	50 x 64 x 62
Machine Dimensions	60w x 62d x 71h
Actual Weight with Accessories	390 lbs
Operating Temperature Range	32-122F / 0-50C

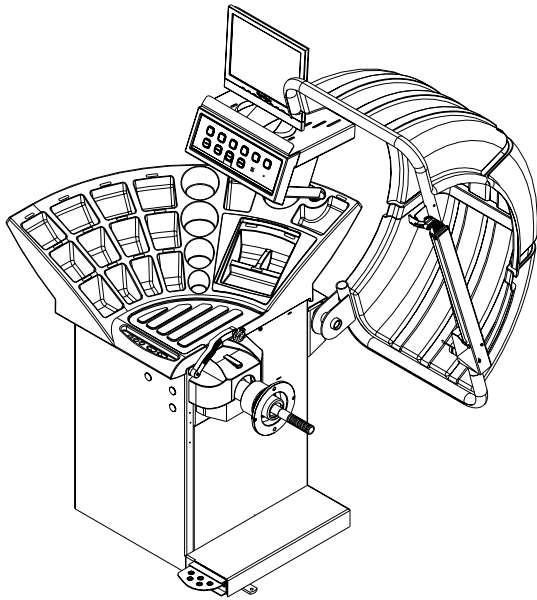

1.4 FEATURES

ACCURACY

- Weight placement accuracy is ± .7°
- Weight imbalance accuracy to 2 grams.
- Self test check with every power up cycle.
- Fast operator calibration.
- Pre-programmed Error Codes indicate procedural errors or safety concerns.

SPEED and DURABILITY

- Automatic "3D" parameter entry. Simply touch the SAPE arm to the inside of wheel and width gauge to the outside, all parameters are automatically entered.
- Distance gauge auto stop feature.
- Quick clamp speed nut offers fast mounting time
- Captured back spring eliminates having to handle the backing spring.
- Quick cycle time.
- Automatic recalculation if weight positions are changed. No need for re-spinning the wheel.
- Common 40 mm diameter mounting shaft.
- Weight pocket storage tray.
- Easy-to-Read Data display.
- Easy weight tray access.

SOFTWARE VERSATILITY

- Both dual weight Dynamic and single weight Static capability.
- Stop-at-Top features simplifies weight imbalance location
- Match Balance program for reducing weight required.
- Spin counter for monitoring balancer productivity.
- Service code access to all Balancer electronic functions for fast, easy diagnosis.
- Operator selectable roundoff mode.
- Aluminum Modes
- Alu-S mode
- Hidden Weight (Spoke) mode
- Split Weight mode
- Weight Miser™ Feature reduces placed weight and saves shop inventory expense.
- Ounce / Gram feature
- Wheel parameter storage and recall

1.5 STANDARD ACCESSORIES

Standard accessories (Figures 1, 2, and 3,) included with the VPI System IV are:

- | | | |
|----|-------------|------------------------------|
| 1 | EAM0003J08A | Cone, 85-132 mm / 3.3"-5.2" |
| 2 | EAM0003J07A | Cone, 71-99 mm / 2.8"-3.9" |
| 3 | EAM0003J06A | Cone, 56-84 mm / 2.2"-3.3" |
| 4 | EAM0003J05A | Cone, 43-63 mm / 1.7" - 2.5" |
| 5 | EAC0058D07A | Cup - Pressure |
| 6 | EAC0058D08A | Disk - Pressure |
| 7 | EAA0263G66A | Quick Nut |
| 8 | EAM0005D40A | Weight - Calibration |
| 9 | EAM0021D90A | Standard 40mm Stub Shaft |
| 10 | EAA0247G21A | Caliper - Rim Width |
| 11 | EAC0060G02A | Flange - Cover, Hook |
| 12 | EAM0006G01A | Pin - Accessory |
| 13 | 58839 | Weight Pliers |
| 14 | EAM0005D34A | Fastening Rod |
| 15 | EAC0058D15A | Soft Protector ring |

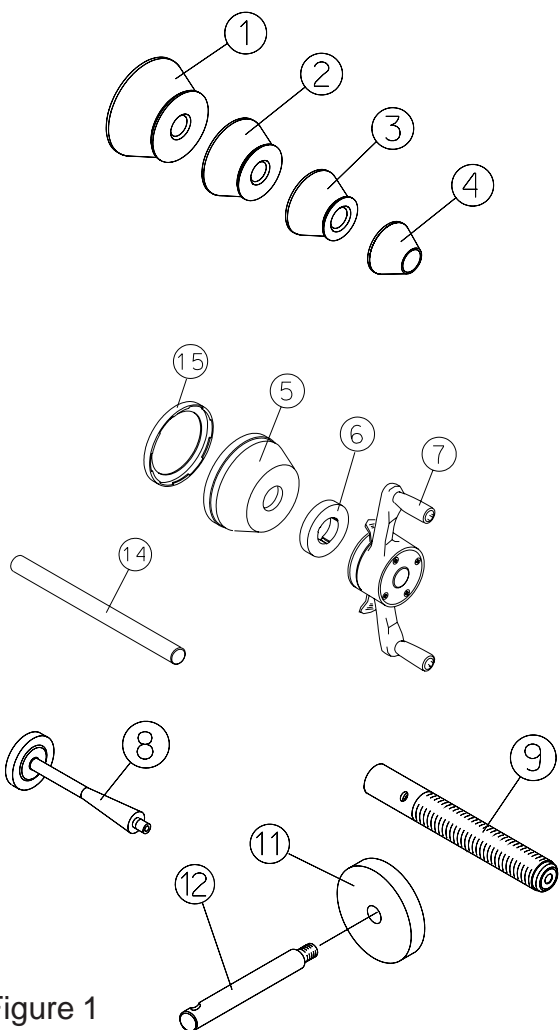

Figure 1

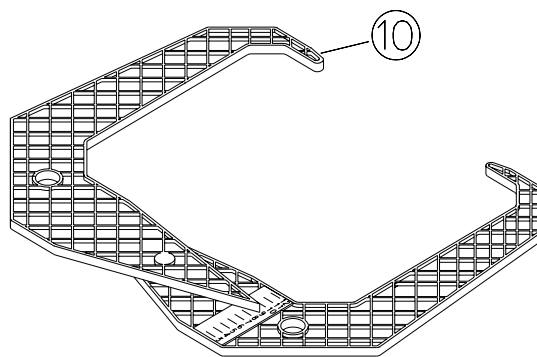

Figure 2

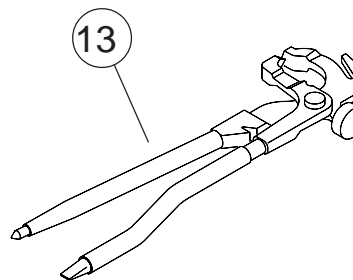

Figure 3

PRE-INSTALLATION CONSIDERATIONS

1.6 DIMENSIONS OF THE MACHINE

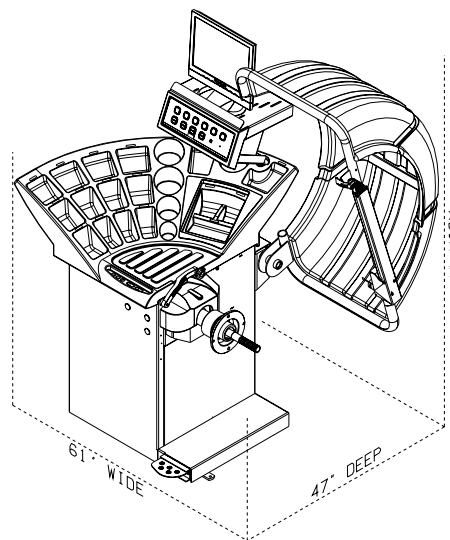

Figure 4 - Actual Footprint Dimensions.

1.7 REQUIRED INSTALLATION AREA

Make sure that from the operating position the user can see all of the machine and the surrounding area.

The operator should prevent non authorized persons and/or objects from entering the area which may create potential hazards.

The machine should be installed on a stable level floor. Do not install the machine on a uneven floor.

If the balancer is to be installed on a raised floor, the floor must have a capacity of at least 110lbs per sq ft. (5000 N/m² - 500 kg/m²).

It is not required to secure the machine to the floor.

Install the machine in a dry, covered area.

The installation of the machine requires a working area of at least 64" x 64" (1625 x 1625 mm) (Figure 5).

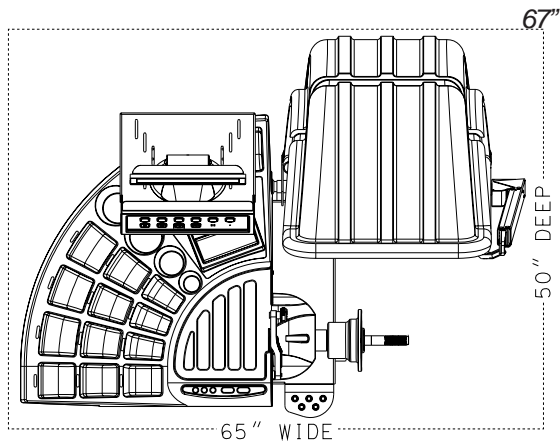

Figure 5 - Recommended Work Area

2.0 INSTALLATION INSTRUCTIONS

CAUTION! CAREFULLY REMOVE THE BALANCER FROM THE PALLET.

Remove the hardware that secures the machine to the pallet and slide the balancer onto the floor where it is to be installed.

THE UNIT IS HEAVY AND THE WEIGHT IS NOT EVENLY DISTRIBUTED.

DO NOT LIFT THE BALANCER BY THE SHAFT.

DROPPING THE UNIT MAY CAUSE PERSONAL INJURY OR EQUIPMENT DAMAGE.

2.1 COMPONENT INSTALLATION

Mounting the Standard Shaft Adapter

IMPORTANT!

CHECK THAT THE SURFACES ARE PERFECTLY CLEAN AND NOT DAMAGED. AN INCORRECT MOUNTING MAY RESULT IN SIGNIFICANT IMBALANCE. UNITS SUPPLIED WITH THE OPTIONAL POWER CLAMP ARE SHIPPED ASSEMBLED.

A. Mount the threaded shaft onto the arbor of the balancer. Tighten firmly using supplied rod. (Figure 6).

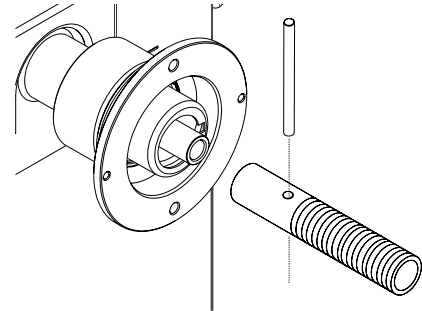

Figure 6

B. Install the 4 accessory pins (Figure 7). Tighten firmly.

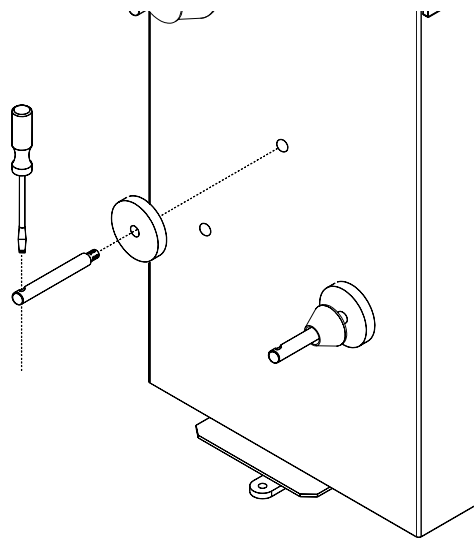

Figure 7

C. Place accessories onto the accessory pins.

2.2 HOOD GUARD INSTALLATION

The safety hood guard is standard equipment and must be installed prior to use.

Refer to Figure 8 for hood guard installation.

Parts Required:

- (1) Hood Guard Assembly
- (1) 3/8" - 16 x 2" HHCS
- (1) 3/8" x 16 Keps

Position the hood guard in the raised (up) position.

Slide the hood guard support tube over the frame pivot shaft protruding from the right side of the balancer cabinet.

Line up the mounting holes in both the pivot shaft and the guard support tube. Secure the guard with 3/8" hardware.

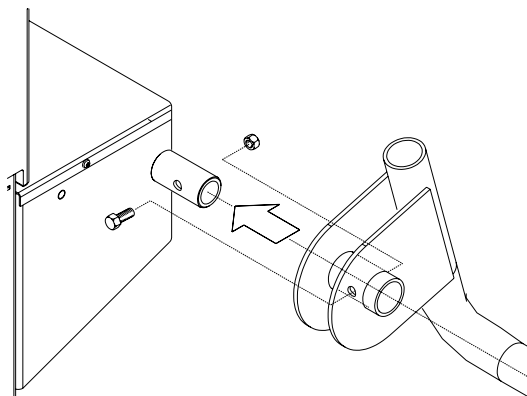

Figure 8

2.3 WIDTH SAPE ARM INSTALLATION

Connect the SAPE arm cable to the harness connector exiting the rear of the cabinet. This connector is keyed to be inserted only one way. Do not force connection.

2.4 ELECTRIC INSTALLATION

ANY ELECTRICAL WIRING MUST BE PERFORMED BY LICENSED PERSONNEL.

ALL SERVICE MUST BE PERFORMED BY AN AUTHORIZED SERVICE TECHNICIAN.

Check on the plate of the machine that the electrical specifications of the power source are the same as the machine. The machine uses 230VAC, 50-60Hz, 1Ph, 3.2 Ampere.

NOTE:
ANY ELECTRICAL OUTLET INSTALLATION MUST BE VERIFIED BY A LICENSED ELECTRICIAN BEFORE CONNECTING THE BALANCER.

NOTE:
THIS MACHINE PERFORMS A SELF-TEST ROUTINE ON START-UP. THERE WILL BE A DELAY OF SEVERAL SECONDS BEFORE THE DISPLAY IS ACTIVATED.

2.5 INSTALLATION OF THE MONITOR

- A. Place the display monitor onto the top of the control housing. Secure with the band strapping.
- B. Connect the video and power cables to the monitor.
- C. Connect the video cable to the video port located at the rear of the control housing.
- D. Connect the power cord to a power outlet. The monitor is designed to operate on either 115 or 230 volt AC 50/60 Hz. No switching is required.

2.6 USER SETUP

Every shop has different procedural requirements meaning each machine should be customized to the unique services performed at that location. Most attributes are set from the Main Function menu.

2.6.1 Customizing the System

- A. Select the “Function” key (F1) from the “Welcome” menu. The Main Function setup screen appears as in Figure 9 as show on next page.
- B. Press and hold the “F6” button and rotate the shaft to scroll up or down to the desired line item.
- C. Press and hold the “F5” button and rotate the wheel to change selected topic to desired value or function.
- D. When the desired features have been selected, save selections to permanent memory by selecting line item “2”. Hold the F5 button while rotating the shaft, enter a value of “1”, release to **Save to Permanent Memory**.
- E. Select the “ESC” button on the keyboard to return to the main screen.

Setting factory default modes of operation	0
Saving modes of operation in permanent memory	0
Language selection	English – uk
Volume of the audible signals	50
Resolution of the unbalance amount readings	Normal
Suppression of minor unbalance readings	On
Setting threshold value for unbalance suppression in oz	0.25 oz
Measurement unit of the unbalance amount readings	Ounces
Number of revolutions	10
Starting a measuring run by closing the wheel guard	On
Automatic braking when wheel guard is raised	On
Date: Day	16---
Date: Month	--.01.--
Date: Year	---.08
Time: Hour	09:--
Time: Minute	--:00
Counter (total spins / spins with ok)	38 0
Counter (optimisation runs)	0
Counter (since last calibration / service)	4 17
Screensaver timeout (0 = disabled)	0
Position brake and indexing	2
Networkmode (0=no network, 1=ASA)	0
Machine name in network	WB01
Rim cleaning position brake control	Off
WeightMiser	On
Setting static threshold value for WeightMiser in oz	0.20 oz
Setting dynamic threshold value for WeightMiser in oz	0.35 oz
WeightMiser clip weight to money conversion	9 / lb
WeightMiser stick weight to money conversion	11 / lb

Figure 9 - Function Menu

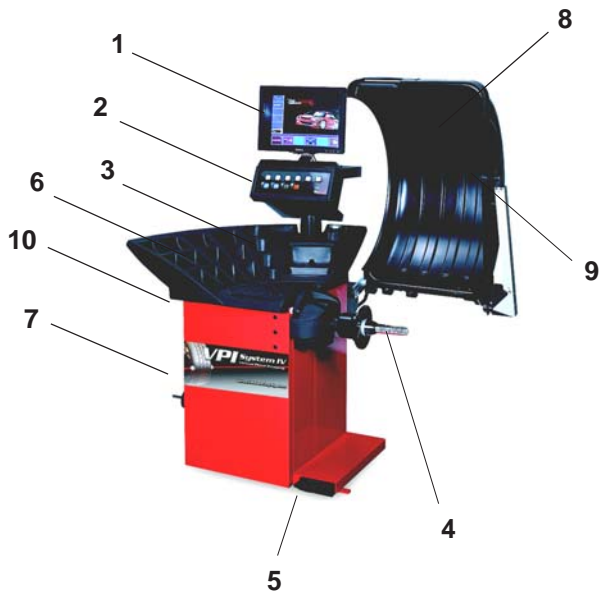

Figure 10

3.0 PHYSICAL LAYOUT

Refer to Figure 10. - Functional description of the unit:

1. The Monitor
2. Input panel
3. Gauge arm
4. Stub shaft
5. Brake pedal
6. Weight compartments
7. Storage areas for cones or clamping devices
8. Tilting frame and hood guard
9. Width Gauge Arm
10. Main Power switch (ON/OFF), rear

3.1 The Display Screen

See Figure 11, Screen with display fields

- 1-5 Information fields
- 6 Menu fields and Function descriptors.
- 7 Display field of screen
The screen reads out inputs, helpful information, all measured data and error codes.

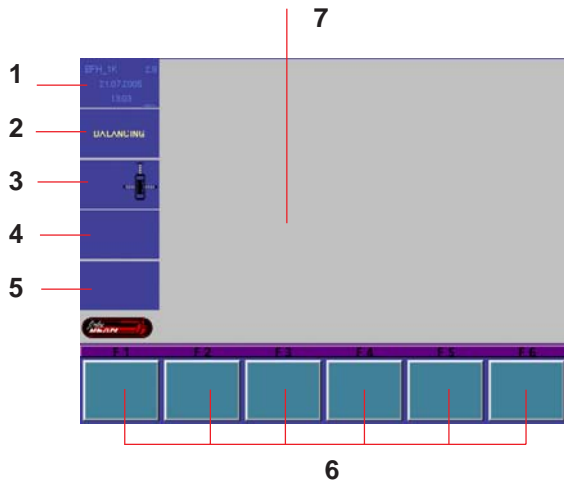

Figure 11

Detailed description of display fields

The screen is subdivided into various display fields, each of which is associated with a certain type of information.

Information fields

- 1 Number of the installed program version
Machine name
Date and time
- 2 Selected Menu name
- 3 Selected profiling mode
- 4 Electrical compensation
- 5 Error codes

6 Menu fields

Icons illustrating special features or functions are viewed in the six menu fields. Under every menu field is the associated menu "F key" which is used to call the feature illustrated.

7 Display field

Wheel type and rim dimensions
Balancing modes
Amount of unbalance
Direction of orientation and correction position
Function and Setup Menus

3.2 Menu Keys

3.2.1 Description of Menu Keys

The assignment of the menu keys **F1** to **F6** is shown in the menu fields above the relative keys on the screen. The menu keys have different functions and initiate different actions, depending on the program step.

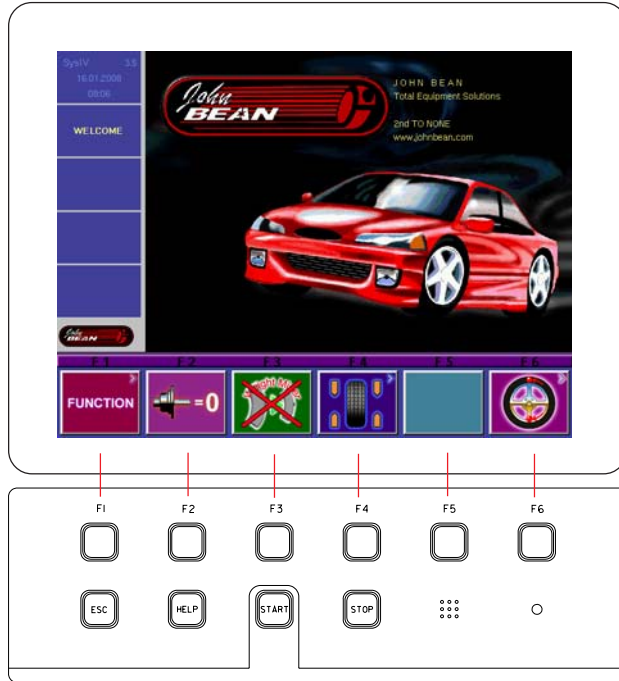

Figure 12

- Keys without a symbol in the upper right-hand corner or at the edge initiate an action immediately, such as F2 on the main screen means to perform a compensation process. See Figure 12.

- Keys with one or more symbols in the upper right-hand corner of the menu field or at the edges initiate various actions:

a - Press key to access a sub-menu, e.g. key F4 Balancing.

b - Press and hold key down while rotating wheel at same time, e.g. key F11 Number of spokes.

c - Press key to toggle between two options or states, e.g. key F9 Static / dynamic unbalance.

d - Press key to toggle between several options or states, e.g. key F21 Weight position for correction plane.

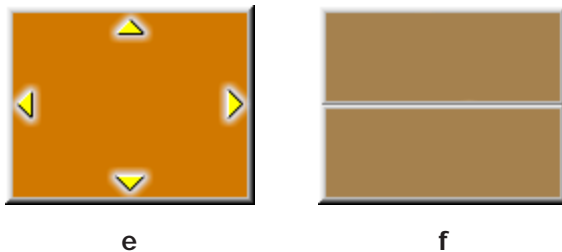
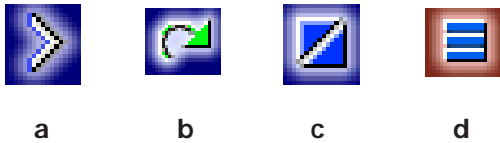

e - Toggle switch (4 functions): Press edge of key to carry out the highlighted action. Character set: move the cursor in the character set to the left, to the right, up or down.

f - Toggle switch (2 functions): Press key on top or bottom to select the highlighted function, e.g. key F8 Precision reading of unbalance and mode select.



Icon 1

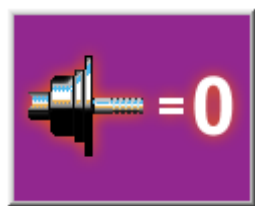

Icon 2

3.2.2 MAIN MENU FUNCTIONS

Icon 1 Change to the Function screen

Icon 2 Perform adapter compensation run

Icon 3 Change to the Balancing screen

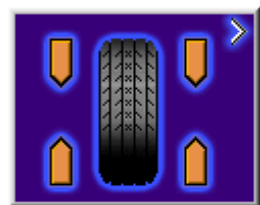

Icon 3

3.2.3 BALANCING

Icon 5 Parameters

View and/or edit Data Input (wheel parameters)
Select if manual parameter entry is desired or required.

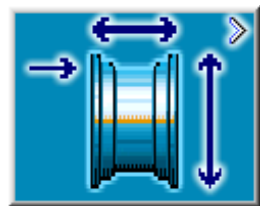

Icon 5



Icon 6

Icon 6 Toggle switch, two functions; reading only as long as the key is pressed (quick reading):

Pressed on top:
Precision reading of unbalance, no suppression of minor unbalance readings.

Pressed on bottom:
Toggles through possible placement locations of weight placement for conventional balancing run.



Icon 7a



Icon 7b

Icons 7a and 7b Select static unbalance or Select dynamic unbalance



Icon 8



Icon 9

Icon 8 Wheel with 6 spokes selected

Icon 9 Number of spokes has not been entered.

1. Press and hold F5 and turn the wheel to enter the number of spokes.
2. Release F5 when the right number of spokes is indicated.
3. Turn the wheel in the way that one spoke is located on the 12 o'clock position.
4. Press F5 and the balancer will split the weight into 2 pieces.
5. Place the weights behind the spokes.

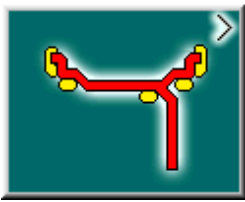

Icon 11



Icon 12

3.2.4 RIM DATA INPUT

Icon 11 Change to the WEIGHT PLACEMENT (mode) screen.

Icon 12 Change to the RIM TYPE screen



Icon 13

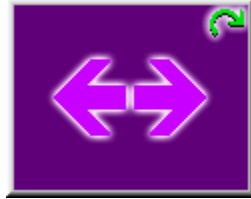

Icon 14

Icon 13 Hold key down and enter the distance rim/machine by rotating the wheel

Icon 14 Hold key down and enter the rim width by rotating the wheel

Icon 15 Hold key down and enter rim diameter by rotating the wheel



Icon 15

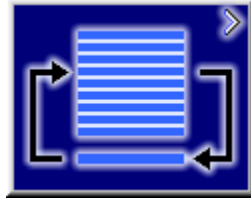

Icon 16

Icon 16 Change to the Stored Parameter menu. Must be in the "Manual" parameter mode

3.2.5 PROFILES SCREEN, STORED PARAMETERS



Icon 17



Icon 18

Icon 17 Select or store a wheel profile. Hold key down and select copy or store by rotating the wheel.

Icon 18 Store a parameter. Select memory location to store current wheel profile for later retrieval (yellow arrow). Select "OK" to enter the values currently in use to a stored location.

Icon 19 Copy a stored parameter. Select memory location for retrieval (yellow arrow). Select "OK" to enter the values stored for use in the next balance run.



Icon 19

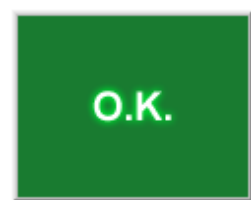

Icon 20

Icon 20 Accept or enter the selected parameters.



Icon 21



Icon 22

3.2.6 FUNCTION MENU

Icon 21 From the Main Menu, Select FUNCTION to access screens used to prepare the unit for desired operation.

Icon 22 Change to the screen USER CALIBRATION, see Maintenance chapter for user calibration procedures.



Icon 23

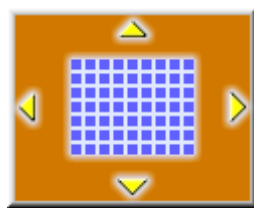

Icon 24

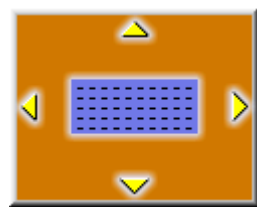

Icon 25

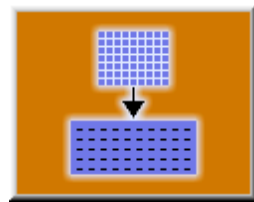

Icon 26



Icon 27

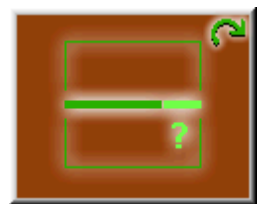

Icon 28



Icon 29



Figure 113

3.2.7 TEXT EDITOR

Icon 23 Change to the screen TEXT EDITOR

Icon 24 Toggle key, four functions: Move the cursor within the character set (right, left, up, down) to the desired character.

Icon 25 Toggle key, four functions: Move the cursor within the text field (right, left, up, down) to the desired text box location

Icon 26 Transfer characters from the character set to the text field

Icon 27 Save text

3.2.8 FUNCTION (SETUP)

Icon 28 Change selected topic to desired value or function.

Icon 29 Hold button and rotate the wheel to scroll up or down to the desired line item.

Setup screen illustration. When desired features have been selected, save to permanent memory by selecting line item "3", Save to Permanent memory, enter a value of "1" with the F5 button while rotating the shaft. Release button to save. Select the "ESC" button to return to the main screen. See Figure 13.

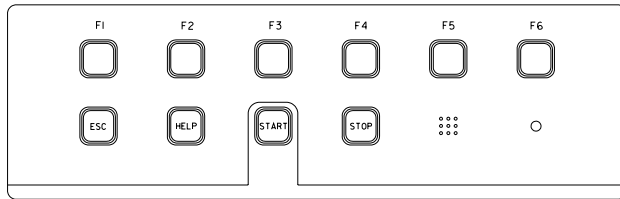

Figure 14

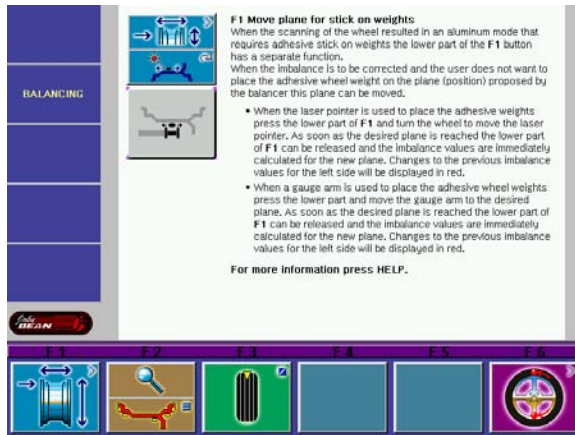

Figure 15

4.0 Help information

Help information explains the current action and, in the case of an error code, provides hints for remedy. See Figure 14.

Display help information

- Press the HELP key (See Figure 15)
- The first screen with help information appears, e. g. to the screen RIM DATA INPUT.
- Press the HELP key once more to display any additional screen with information.

Quit help information

- Press the ESC key

Push down for brake

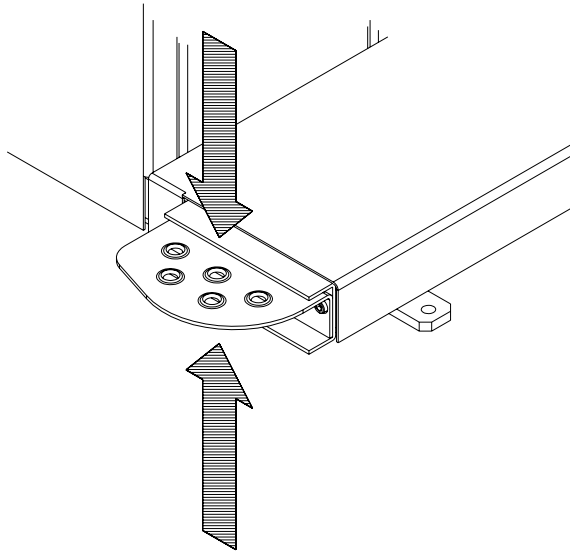

Lift up for power clamp operation

Figure 16

5.0 POWER CLAMP OPTION

5.1 POWER CLAMP PEDAL

Shaft Lock

The main shaft is locked when the pedal is **depressed**. This holds the wheel in the correction position for correct fitting of the correction weights. See Figure 16.

This lock is designed only to facilitate orientation of the wheel and must not be used for braking the main shaft.

Power Clamp Operation.

Lift upward to engage the power clamp jaws when the lock nut is placed on the shaft.

Lift upward again to release the clamp nut.

NOTE: The first time the unit is operated after power-up, make sure the power clamp engaging jaws are in the outer most position and ready for use. An Error of "E14" may result if the unit cannot accurately determine the clamping jaw position. Simple press "ESC" to continue, lift the pedal again to cycle and the power clamp will learn its new position. See Figures 17 and 18.

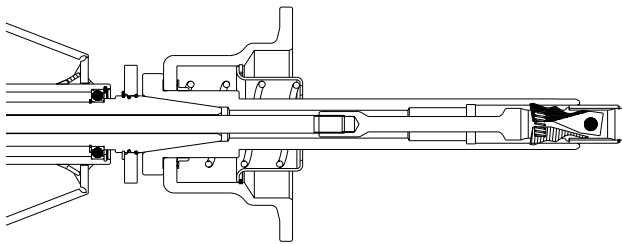

Power Clamp with jaws all the way OUT

Figure 17

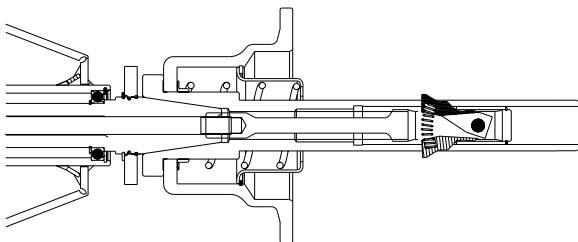

Power Clamp with jaws all the way IN

Figure 18



**SEVERE PERSONAL INJURY WILL OCCUR
IF FINGERS OR HAND IS PINCHED
BETWEEN THE NUT, WHEEL OR FLANGE**

6.0 OPERATION OF THE BALANCER

WARNING: For operator safety please read and follow the precautions outlined at the beginning of this manual.

NOTE: READ ALL INSTRUCTIONS BEFORE PROCEEDING WITH OPERATION OF THE BALANCER.

All balancer functions are input into the main computer through the large easy to read touch panel. Although each wheel tire assembly differ in some ways all balancing jobs require basically the same procedure. The order of events to take place are:

1. Inspection of the wheel/tire assembly
2. Mounting wheel onto shaft
3. Entry of wheel parameters
4. Applying the recommended weight
5. Check spin if desired
6. Dismounting the wheel

The following operation instructions will follow the basic outline above.

6.1 CHECK LIST - INSPECTION

Observe Before Balancing Wheel

1. Check for proper air pressure. If not correct, inflate to correct pressure.
2. Check for any foreign material inside tire. If present, remove before balancing tire.
WATER IS FOREIGN MATERIAL!
3. Remove old weights — old weights may be improper value or in wrong location.
4. Be sure tire and wheel are free of excessive dirt, rust and large stones. Use wire brush on back side of wheel if necessary.

Figure 19



5. From the main menu, see Figure 19 above, select the desired process
 - F1. Function - setup the balancers parameters to perform in a certain fashion
 - F2. Compensate a wheel adapter
 - F3. Select to operate in the "Weight Miser™" mode or not (if activated)
 - F4. Go to the balance process - normal selection for most users**
 - F5. Not Used
 - F6. Optimization process

6.2 BALANCE SCREEN DESCRIPTION

Refer to Figure 20 below for an example of a typical balance screen. The wheel displayed has been profiled as a rim which will accept a stick-on weight on the left and right sides. The stick-on weights will be placed at top dead center when the arrows indicate green. The operator selects the desired mode as indicated by the yellow weight icons, such as stick-stick as shown in the example below. Subsequent wheels will use the same mode until a different profile or parameter is detected.

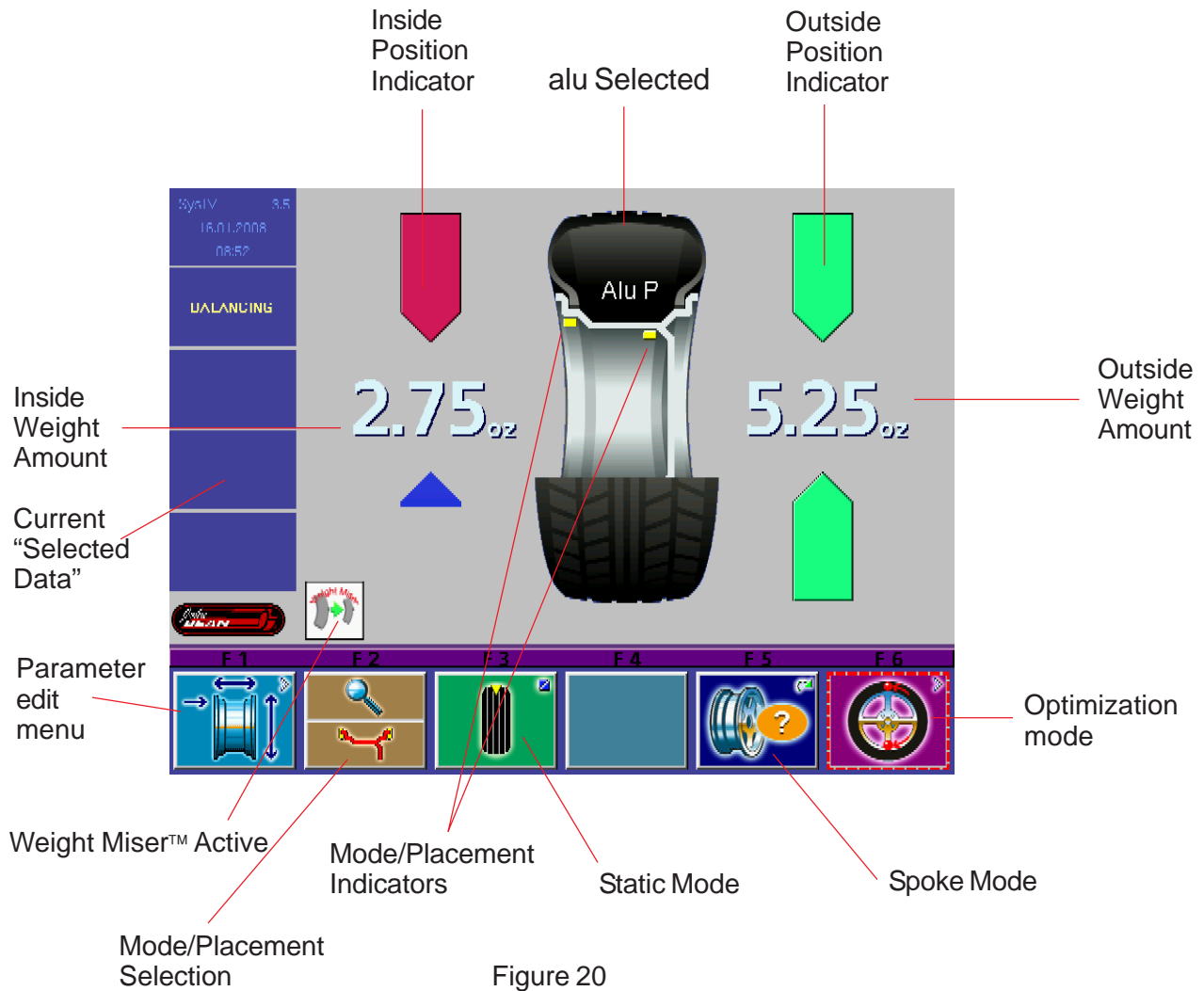

Figure 20

Begin Balance procedures

From the Main Menu, select "F4" to enter the balance mode of operation.



6.2.1 WHEEL MOUNTING

Most standard wheels and many alloy wheels have accurately machined center holes, and they should be mounted with center cones. Accurate balancing depends on accurate mounting of the wheel and correct seating of the cone in the pilot hole. Insure that the wheel is centered on the shaft exactly as it will be mounted to the vehicle.

Before starting any balancing procedure it is very important that the wheel is mounted on the machine with the proper adaptors. An incorrect centering of the wheel will result in considerable imbalance.

There are many types of wheels and John Bean supplies adaptors of high quality and durability for the large majority. However if you meet special wheels which may require a specific adaptor, call your authorized John Bean distributor.

Rims may be divided into these major groups:

1. *Car rims with a true center hole.*
2. *Car rims without a center hole.*
3. *Car rims with an untrue center hole.*
4. *Light truck rims.*

6.2.2 STANDARD WHEELS (BACK CONE MOUNT)

Mount the wheel as detailed below in Figure 21a.

1. Mount proper cone against spring plate.
2. Mount wheel on shaft in the same manner as you would on the car.
3. Mount the Clamp nut along with proper pressure cup.

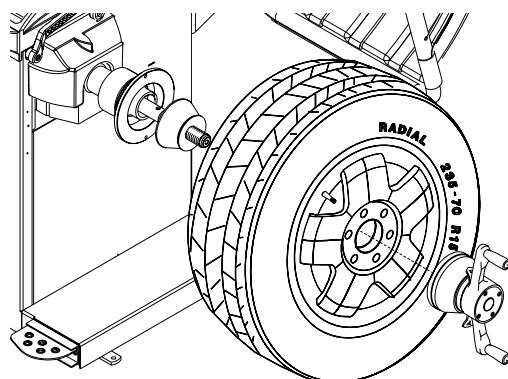

Figure 21a - Standard rear cone mount

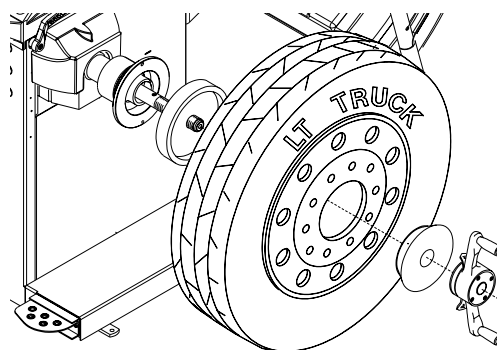

Figure 21b - Truck cone - outside cone mount

6.2.3 CENTERING LIGHT-TRUCK WHEELS

Install the wheel, using the front cone method, See Figure 21b.

An optional offset spacer may be required for some light truck wheels and reverse-offset wheels that must be moved away from the balancer mounting flange. The extension adaptor is often used with the 5-1/4 inch diameter light truck cone.

6.3 ENTERING RIM PARAMETERS

6.3.1 Rim Distance (offset) Rim Diameter and Rim Width - Move the **Rim Offset Arm** to the inside edge of the rim, touch the pointer to the rim edge, touch the tip of the **Width Arm** to the outside rim edge where weights will be placed as illustrated in Figure 22. Hold arms steady for about a second. The beeper will sound when the parameter values are calculated and entered automatically. Return the arms to its home rest position on the balancer. Do not allow the measurement arms to "dangle".

NOTE: The parameter arms must be in the Home rest position when the balancer is powered up. This establishes the arm starting position.

NOTE: For a more precise balancing of performance wheels, an "ALU-S" Mode is available for precision determination of wheel parameters. This feature allows exacting placement of corrective weights as well.

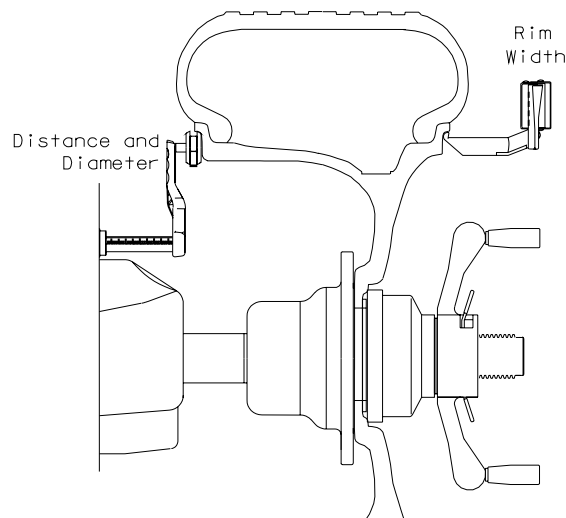

Figure 22

6.3.2 Manual Parameter Entry

In the event of an automatic gauge failure, ANY parameter value can be input manually. Select the "F1" button on the placement screen to view the current selected parameters. See Figure 23 below.



Figure 23

MANUAL PARAMETER ENTRY MODE - Read the rim diameter marked on the sidewall of the tire (Figure 19). Enter the rim parameters manually by pressing the parameter button twice then holding while rotating the wheel assembly until the desired value is displayed. Repeat for desired values for Distance, Width and Diameter.

6.4 SPINNING THE WHEEL

CAUTION: Before spinning the wheel, make sure proper eye protection is worn by all personnel in the vicinity of the balancer.

Spin the wheel by lowering the wheel guard. If auto-spin is not activated press “Start” to begin balancer run. When the balancing cycle is complete the wheel will stop automatically and the imbalance values will appear on the screen.

After a short spin cycle the SYSTEM IV then displays the correction screen for weight placement.

6.5 SELECTING THE WEIGHT PLACEMENT

Figure 24

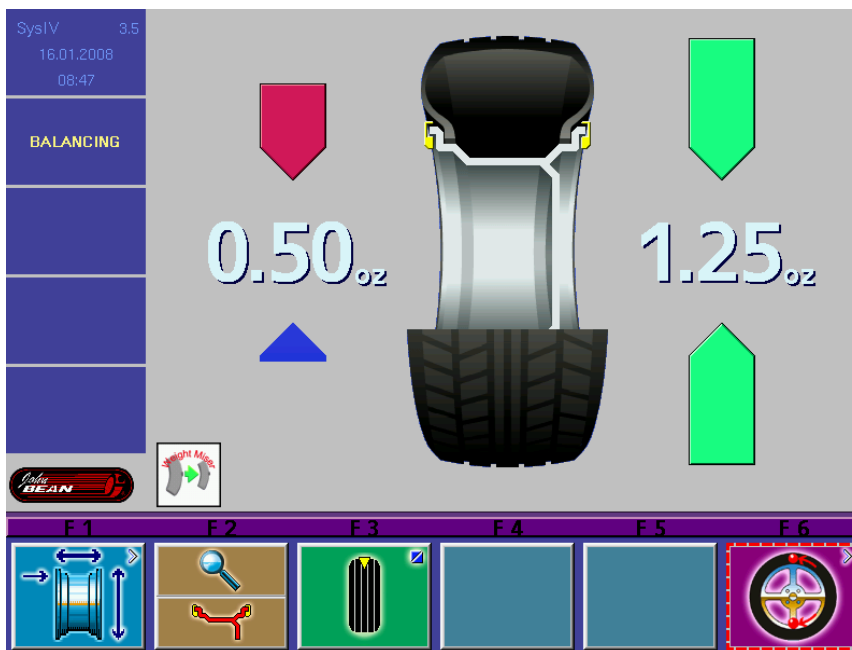

A. 2-Plane - Choose the appropriate balancing mode for the wheel. To select the various 2-plane weight placement modes press the Mode button (Lower part of F2) until the placement graphic indicates desired corrective weight placement position. Press and hold the lower button for 3 seconds goes directly to clip-clip without having to prompt through all the modes. Fig 21

B. STATIC mode. Use a single corrective weight placed in the center or inner edge of rim. Select Static by pressing the “F3” key on the balancing screen. Pressing “F3” again will toggle operation back to Dynamic 2-plane operation.

NOTE: If in the “clip-weight static mode”, the weight placement position will be at top dead center.

6.6 CORRECTION OF THE IMBALANCE

A. The wheel assembly automatically stops near the right weight correction plane.

NOTE: Automatic plane braking can be selected from the Main Function Setup Menu. Factory default is right plane (2), select a value of “1” for braking on the left plane, “0” for none.

B. Read the imbalance value of the right side. Values are displayed in ounces but can be displayed in grams if required and are automatically rounded to the nearest commercial wheel weight.

C. Place the amount of weight called for. Use the foot operated shaft lock to stabilize the shaft during weight placement if required.

D. Press “Start” with the hood up to rotate the assembly to the left or inner correction plane.

E. Place the amount of weight called for. Use the foot operated shaft lock to stabilize the shaft during weight placement if required.

NOTE: If a check spin reading does not “ZERO”, check for proper wheel mounting, weight placement, worn or damaged mounting accessories, or water in the tire etc.

6.7 VERIFICATION OF THE RESULTS

Lower the wheel guard to spin the wheel again and check that the readout is “0.00” “0.00” If a residual imbalance is displayed: Reference Graphic 1 next page for diagnostics explanation below.

NOTE: Make sure the intended balance mode is selected, If Weight Miser™ is selected a small amount of residual un-balance is expected. If the balance requires further attention, disable the Weight Miser™ mode

A. Check the rim parameters, if entered value is incorrect, correct as needed. Imbalance values will be automatically re-computed.

B. Check if the balancing mode selected is the most appropriate. If not, choose the right mode and re-spin.

C. The wheel weight could have been placed at a wrong position. To check this, position the wheel at the correction position for the outer plane. If the wheel weight previously attached is in sector ‘L’ or ‘R’ (Graphic 1, page 20), move the wheel weight up about 1” (2.54cm).

If the wheel weight is in sector ‘D’ cut a piece of the wheel weight of an approximate value corresponding to the value shown on the right display, or replace the wheel weight with a lighter one.

If the wheel weight is in sector ‘U’ add a weight of value indicated by the display or replace the wheel weight with a heavier one. Repeat the same operation for the inner plane.

NOTE: If this situation is repeated, your machine may be out of calibration and a calibration operation might be required, contact a service representative for re-calibration.

D. If an *ALU* function was selected ensure the wheel weights have been placed in accordance to the program chosen.

E. Check that the wheel is not slipping against the backing collar.

F. Check that the wheel and adaptors are clean.

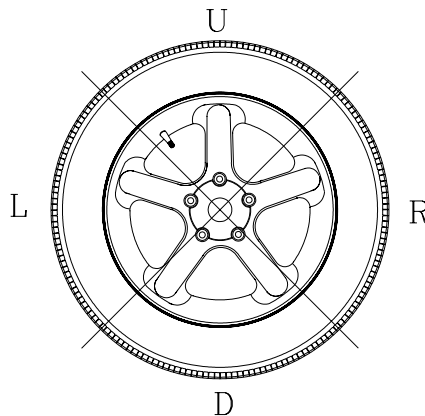

Graphic 1.

6.8 VIBRATION PROBLEMS

If vibration is still present after balancing, check the following possible sources of vibration:

1. Stones caught in the tire tread.
2. Tire slippage on the wheel.
3. Incorrectly mounted wheel.
4. Imbalanced wheel covers.
5. Excessive radial or lateral runout in the tire or wheel.
6. Damaged wheel bolt holes.
7. Worn universal joints.
8. Imbalanced brake rotors or drums.
9. Worn or damaged balancer accessories.

7.0 SPOKE BALANCING MODE

A standard dynamic balance in ALU mode places compensation weight in two planes, inner and outer, at the bottom dead center for each plane of calculated imbalance. Sometimes the outside weight placement may be unsightly on a custom wheel. The Spoke Mode is designed to “hide” outer plane corrective weight by placing the required weight behind selected spokes in order to retain the esthetic appeal of the wheel.

1. Press the Spoke button, F5.
2. Outer weights will be divided. Weights may not be equal depending on the spoke positions relative to the imbalance position.
3. Place stick-on weights top dead center, 12 o'clock.
4. Perform a check spin if desired.



Figure 25

8.0 Optimisation Procedures

1. Optimisation is a tire - rim matching procedure used to minimize placed weight. This matching procedure can also minimize radial runout in many cases where the runout high point is associated with the measured heavy point. The Optimisation procedure can begin with a bare rim or by starting with a tire/rim assembly.

Select softkey "F6" to continue to the matching process. See Figure 25.



Figure 26

2. From the Screen displayed in Figure 26, select "F5" to begin matching a tire/rim assembly, select "F6" to begin the matching process with a bare rim.

The example procedure shown will select a tire/rim assembly.



Figure 27

3. Rotate the assembly so the valve stem is located at top dead center. Press "F6", to continue. See Figure 27.



Figure 28

4. Press the "Start" button to begin a measure run. See Figure 28.

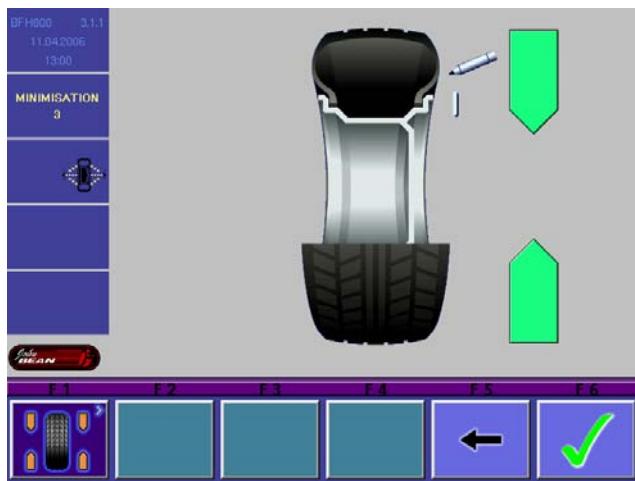

Figure 29

5. Rotate the assembly so the arrows are both GREEN, as shown in Figure 29. Mark the tire at top dead center. Select "F6" to continue.



Figure 30

6. Remove the Wheel assembly from the balancer and break the bead using a tire changer. Rotate the tire on the rim so the mark and valve stem are lined up. See Figure 30. Select "F6" to continue.



Figure 31

7. Reinflate the tire to specifications.

Mount the assembly back onto the balancer as before.

Rotate the tire/rim assembly so the mark-valve stem is straight up, or at the 12:00 o'clock position. See Figure 31. Press "F6" to continue.



Figure 32

8. Select "Start" See Figure 32.

The unit will re-profile and recalculate based on the new tire-rim combination.

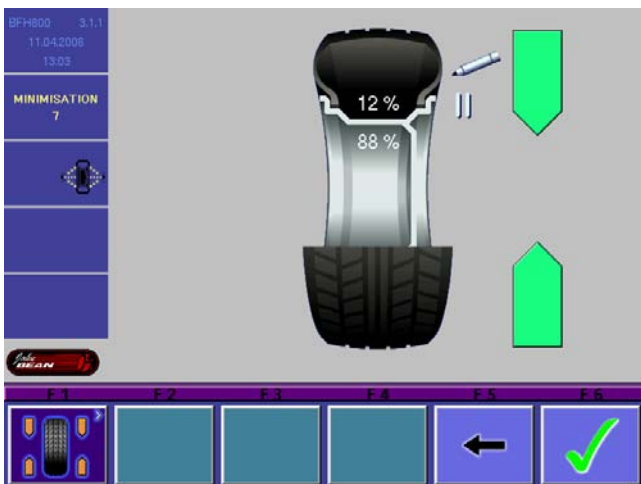

Figure 33

9. Rotate the assembly until the arrows turn Green as shown in Figure 33. Mark the tire with two (2) marks.

Select "F6" to continue.



Figure 34

10. Remove the tire/rim assembly from the balancer and break the bead using a tire changer. Rotate the tire on the rim so the double mark and valve stem are lined up. See Figure 34.



Figure 35

11. Reinflate the tire to specifications.
Mount the assembly back onto the balancer as before.

Rotate the tire/rim assembly so the mark-valve stem is straight up, or at the 12:00 o'clock position. See Figure 35. Press "F6" to continue.



Figure 36

12. Select "Start" See Figure 36.
The unit will re-profile and recalculate based on the new tire-rim combination.



Figure 37

13. If the match procedure was successful an “OK” will be displayed as shown in Figure 37.

Press “F6” to continue to the balance screen for weight placement.



Figure 38

14. Corrective weight amounts and locations will be displayed. See Figure 37.



Figure 39



Figure 40

Weight Miser™ is enabled



Figure 41

Disabled

9.0 WEIGHT MISER™

INTRODUCTION - The System IV Weight Management Software features consist a unique program designed to maximize the tire shops profits while maintaining efficiency. **Weight Miser™** works to reduce weight costs, and minimize excessive weight inventory. Weight inventory can be tailored by location requirements to avoid waste.

9.1 Weight Miser™

Weight Miser™ is a software program that determines if there is the possibility to remove sufficient vibration from a tire and wheel assembly by applying a lower amount of weight than the normal balance function recommends. The amount of residual imbalance left on the tire and wheel assembly is determined by the residual threshold tolerance setting.

Assuming that an amount of residual imbalance accepted nowadays by the automotive industry standards is 5 grams for static imbalance and 10 grams for dynamic imbalance, a new feature Weight Miser allows the tire shop to achieve wheel balancing using less – smaller – balancing weights.

It must be very clear that the feature works assuming that some residual imbalance can be left on the wheel. The tire shop will save weight, but wheels will be balanced with a lower degree of accuracy.

The feature – Weight Miser™ – is disabled by default when the unit is manufactured. The machine will leave the factory in its original high-accuracy balancing configuration.

The user has the option to activate the feature from the “**Main Menu**”. See Figure 41. Press the “F3” key to activate Weight Miser. The feature is activated when the green icon with the “X” is shown at the “F3” position as shown.



Figure 42

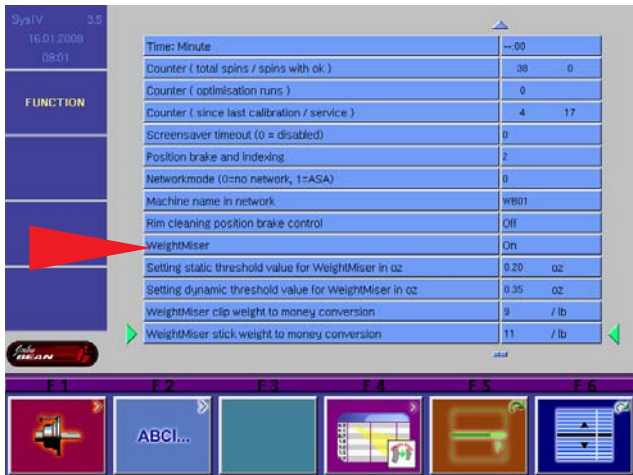

Figure 43



Figure 44

When in the Weight Miser™ mode, software determines if a single weight approach is feasible. If it is possible to reduce both static and dynamic imbalance below the given thresholds using a single weight, then a single weight will be recommended. If not, two-weight balancing will be recommended, but the weight amounts can be lower.

There are five entries in the “Function Menu” for Weight Miser™ setup. See Figure 43.

1. Weight Miser™ feature enable – ON/OFF (Function default is OFF)
2. Weight Miser™ static threshold
3. Weight Miser™ dynamic threshold
4. Clip weight to money conversion
5. Stick weight to money conversion

The two thresholds for Weight Miser™ are adjustable. There is a recommended pre-set limiter.

The Weight Miser™ thresholds can be set in the set up function screen as described. Furthermore, a quick way to change thresholds is the vehicle type selection.

For the vehicle category – SUV and Truck, there is a multiplier that increases the threshold from the preset **CAR** values due to the fact that these vehicle types can tolerate a higher residual imbalance. See Figure 44.

Vehicle type	Threshold
Passenger Car	1x
Motorcycle	1x
SUV	1.5x
Light Truck	2x

The weight to money conversions are adjustable to display the approximate amount of money savings relative to the weight savings. The user can change the value of conversion depending upon his weight purchase costs

To observe the Weight Miser™ screen as shown in Figure 42, press the F5 button when in the Weight Wizard™ screen.

10.0 USER CALIBRATION

The SYSTEM IV Balancer features a user calibration program which requires only a few minutes to complete. Perform this procedure when the balancer has been moved, disturbed, or whenever accuracy is questioned. Occasional field calibration will ensure years of reliable service.

Follow these 3 simple steps for shaft calibration:

1. Press and release the **“Function”** key (F1) from the **“Welcome or Main Screen”**.
2. Press and release the **“Calibration”** key (F1). Fig 45.



Figure 45

3. Place 2 cones followed by the clamping nut (no retainer) onto the shaft. Lift the pedal to clamp. See Figure 46.

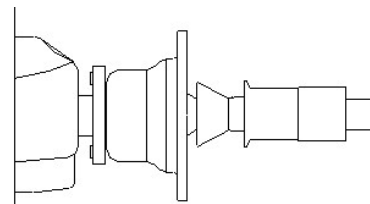

Figure 46 - 2 cones & clamping nut only

4. Lower the wheel guard and press the **“SPIN”** key. The balancer should spin and come to a complete stop. See Figure 47.

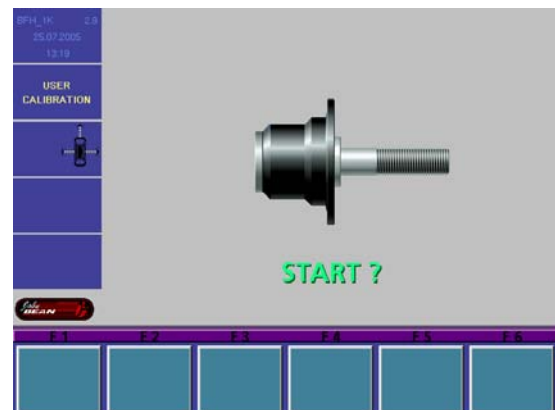

Figure 47

4. After the balancer comes to a stop raise the wheel guard and screw the calibration slug into left side of the flange plate. Lower the wheel guard and press the **“SPIN”** key. The balancer should spin and come to a complete stop. Once the shaft stops the display should display **“OK”** and the speaker sounds the Snap-on **“TüDüLü”**. See Figure 48.



Figure 48

SHAFT CALIBRATION IS COMPLETE

11.0 EXPLANATION OF PROGRAM CODES

In the event of damage or malfunction, a code may be displayed indicating the area or location of the detected error. These codes are important to the service agent when he services the unit. Note any codes or error messages before calling for service or assistance.

1. Communication between micro-controller and embedded PC (Blue screen)

Service Codes: No service code available Communication between micro-controller and embedded PC is not OK (check connecting cable). This can also indicate a bad connection to the keyboard.

2. Check availability of keyboard (E 300)

Service Codes : No service code available The microcontroller was not able to detect a keyboard. Check cabling between microcontroller and keyboard.

5. Check keyboard (E 89)

One of the keys F1 to F6, HELP, ESC, START supplies a "Stuck key" code. The machine will proceed with the next step only if the trouble is remedied.

6. Check pedal switches (E 89)

Press STOP or ESC key to check the pedal switch once to delete the error code reading. If the trouble cannot be remedied, the pedal is made inoperative.

7. Power clamp service interval expired E93

8. Hardware test disturbed H 82

A. Hardware test -common errors

C10F02 -Test returned with an error. No valid test results available

C10F07-Test function reported an unknown error

C10F18-Test timed out. No valid test results available

B. Hardware test -Power supply voltage

C10800

C10801

C10804

If the line voltage is below or above a limit the error code is displayed.

C. Hardware test -5V line

C10810

C10811

If the 5V voltage is below or above a limit the error code is displayed.

D. Hardware test -Current of optoelectronic LED

C10705

C10706

C10707

C10708

If the current / voltage is below or above a limit the error code is displayed.

E. Hardware test -Transducer signals

- C10410**
- C10420**
- C10430**

Checks transimpedance and signal amplifiers and transducer values. If no signals from the transducers are detected the error code is displayed.

F. Hardware test -Auto stop system

- C10380**
- C10381**
- C10382**
- C10383**

Checks voltage on capacitor of the auto stop system.
If the voltage is below or above a limit or the recharging time is above a limit the error code is displayed.

12.0 MAINTENANCE

BEFORE ANY MAINTENANCE OR REPAIRS ARE ATTEMPTED THE MACHINE MUST BE DISCONNECTED FROM THE ELECTRIC SUPPLY.

This balancer does not require any special maintenance, but the following precautions are required:

- A.** Periodically clean all plastic parts with a glass cleaner. Wipe with a dry cloth.
- B.** Clean all adapters regularly with a nonflammable liquid detergent all. Lubricate with a thin layer of oil.
- C.** Periodically perform a routine shaft calibration as outlined on page 24 of this manual.

13.0 TROUBLE SHOOTING

<u>TROUBLE</u>	<u>CAUSE</u>	<u>REMEDY</u>
When turning the machine on, the displays do not light	No electric power Defect in the electric/electronic system	Check the input voltage Call the Equiserv service center for assistance
The machine gives random readouts.	Machine unstable on the floor Water in the tire Loose adaptor Defective electronic board	Check that machine is stable Remove water from tire. Tighten the adaptor firmly Call the Equiserv service center for assistance
The machine does not stop after balancing cycle	Defective electronic component	Stop using the machine immediately and call the Equiserv service center for assistance
The balancer is slow to display when powering machine up.	This machine performs a self-test routine on start-up. There will be a delay of several seconds before the display is activated.	This is a normal characteristic of the machine
If the balancer ceases to properly measure parameter values	Malfunction of one of the Parameter arms or harness connection failure.	Call the Equiserv service center for assistance

NOTES:

NOTES:



USA

Snap-on Equipment
309 Exchange Avenue
Conway, Arkansas 72032
Tel.: (800) 362-8326 or (501) 450-1500
Fax: (501) 450-1585

UNITED KINGDOM

UK Equipment Ltd
48 Sutton Park Avenue,
Reading RG6 1AZ
Tel: +44(0) 118 929 6811
Fax: + 44 (0) 118 966 4369

LATIN AMERICA

International Equipment Group
309 Exchange Avenue
Conway, Arkansas 72032
Tel.: (501) 450-1526
Fax: (501) 450-2086

ITALY

Snap-on Equipment s.r.l.
via Prov. Carpi, 33
42015 Correggio (RE)
Tel: 39 0522 733600
Fax: 39 0522 733610

CANADA

John Bean
6500 Millcreek Drive
Mississauga, Ontario
Canada L5N 2W6
Tel: (905) 814-0114
Fax: (905) 814-0110

FRANCE

Snap-On Equipment France
Za du Vert Galant
15, rue de la Guivernone BP 7175
95310 Saint-Ouen-L'Aumône
Tel: +33 (0) 1-3448-5894
Fax: +33 (0) 1-3448-5870

GERMANY

Snap-on Equipment GmbH
Werner-von-Siemens-Str. 2
64319 Pfungstadt
Tel: +49 (0) 6157 12 600
Fax: +49 (0) 6157 12 601

Notice: The information contained in this document is subject to change without notice. **Snap-on Equipment** makes no warranty with regard to this material. **Snap-on Equipment** shall not be liable for errors contained herein or for incidental consequential damages in connection with furnishings, performance, or use of this material.

This document contains proprietary information which is protected by copyright and patents. All rights are reserved. No part of this document may be photocopied, reproduced, or translated without prior written consent of **Snap-on Equipment**.

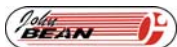

is a registered trademark of Snap-on Incorporated