

**BFH 1000 and BFH 1000 Super  
EEWB519B and EEWB519S**

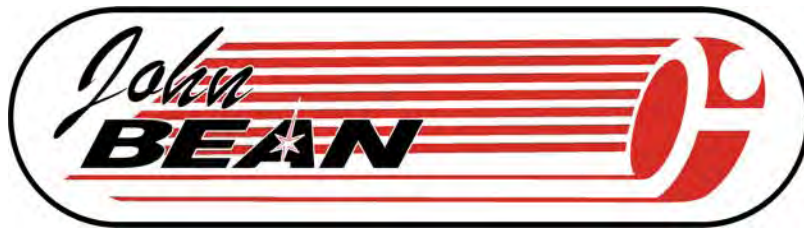

**COMPUTER RIDE DIAGNOSTIC  
WHEEL BALANCER**



**OPERATION INSTRUCTIONS**

*Blank page*

# SAFETY INFORMATION

---

**For your safety, read this manual thoroughly  
before operating the BFH 1000 or BFH 1000 Super Wheel Balancers**

The JBC BFH 1000 and BFH 1000 Super Ride Diagnostic Wheel Balancers are intended for use by properly trained automotive technicians. The safety messages presented in this section and throughout the manual are reminders to the operator to exercise extreme caution when servicing tires with these products.

There are many variations in procedures, techniques, tools, and parts for balancing tires, as well as the skill of the individual doing the work. Because of the vast number of wheel and tire applications and potential uses of the product, the manufacturer cannot possibly anticipate or provide advice or safety messages to cover every situation. It is the automotive technician's responsibility to be knowledgeable of the wheels and tires being serviced. It is essential to use proper service methods in an appropriate and acceptable manner that does not endanger your safety, the safety of others in the work area or the equipment or vehicle being serviced.

It is assumed that, prior to using the BFH 1000 or BFH 1000 Super Ride Diagnostic Wheel Balancer, the operator has a thorough understanding of the wheels and tires being serviced. In addition, it is assumed he has a thorough knowledge of the operation and safety features of the rack, lift, or floor jack being utilized, and has the proper hand and power tools necessary to service the vehicle in a safe manner.

Before using the BFH 1000 or BFH 1000 Super Ride Diagnostic Wheel Balancer, always refer to and follow the safety messages and service procedures provided by the manufacturers of the equipment being used and the vehicle being serviced.



**IMPORTANT !! SAVE THESE INSTRUCTIONS -- DO NOT DISCARD !!**

# IMPORTANT SAFETY INSTRUCTIONS

When using this equipment, basic safety precautions should always be followed, including the following:

1. **READ ALL INSTRUCTIONS.**
2. **Do not operate equipment with a damaged power cord or if the equipment has been damaged - until it has been examined by a qualified authorized service technician.**
3. **If an extension cord is used, a cord with a current rating equal to or more than that of the machine should be used. Cords rated for less current than the equipment may overheat. Care should be taken to arrange the cord so that it will not be tripped over or pulled.**
4. **Always unplug equipment from electrical outlet when not in use. Never use the cord to pull the plug from the outlet. Grasp plug and pull to disconnect.**
5. **To reduce the risk of fire, do not operate equipment in the vicinity of open containers of flammable liquids (gasoline).**
6. **Keep hair, loose fitting clothing, fingers and all parts of the body away from moving parts.**
7. **Adequate ventilation should be provided when working on operating internal combustion engines.**
8. **To reduce the risk of electric shock, do not use on wet surfaces or expose to rain.**
9. **Do not hammer on or hit any part of the control panel with weight pliers.**
10. **Do not allow unauthorized personnel to operate the equipment.**
11. **Do not disable the hood safety interlock system or bypass the intended operation.**
12. **Use only as described in this manual. Use only manufacturer's recommended attachments.**
13. **Always make sure the power clamp is secure before spinning the shaft.**
14. **ALWAYS WEAR SAFETY GLASSES. Everyday eyeglasses only have impact resistant lenses, they are NOT safety glasses.**
15. **Balancer is for indoor use only.**
16. **This equipment uses class II lasers. Do not look into or allow bystanders to look into the laser source.**

**SAVE THESE INSTRUCTIONS**

**CAUTION!** This product uses LASER RADIATION for measurements. DO NOT STARE INTO BEAM.

Refer to these laser safety statements whenever this sign is displayed.



Peak power 1.0 mW.  
Pulse duration 5 m sec.  
Emitted wavelength 650nm.

Class II laser product. Caution - the use of optical instruments with this product will increase risk of eye hazard.



**WARNING!!! DO NOT STARE INTO LASER BEAM! EYE INJURY MAY OCCUR WITH PROLONGED EYE CONTACT WITH LASER. AVOID EYE CONTACT WITH THE LASER SCANNERS**

**WARNING!!! IN THE EVENT OF MACHINE MALFUNCTION, DO NOT LOOK INTO THE LASER AREA. PROLONGED EXPOSURE TO THE LASER MAY CAUSE EYE INJURY.**



PERFORM REGULAR CLEANING OF THE LASER SCANNER GLASS TO ENSURE OPTIMUM OPERATION.

DO NOT KNOCK OR TAMPER WITH THE LASER SCANNERS

ALWAYS OPERATE THE WHEEL BALANCER WITHIN THE RANGES STATED IN THE LABEL SHOWN BELOW.

CAUTION! - Use of Controls or adjustments or performance of procedures other than those specified herein may result in hazardous radiation exposure.



**WARNING!!!SEVERE PERSONAL INJURY WILL OCCUR IF FINGERS OR HAND IS PINCHED BETWEEN THE CLAMP NUT, WHEEL OR FLANGE**



# Table of Contents

<b>SAFETY INFORMATION</b> .....	<b>1</b>
1.0 INTRODUCTION .....	3
1.1 SAFETY NOTICE .....	4
1.2 BALANCER APPLICATION .....	4
1.3 BFH 1000 SPECIFICATIONS .....	4
1.4 FEATURES .....	5
1.7 DIMENSIONS OF THE MACHINE .....	7
1.8 INSTALLATION AREA REQUIREMENTS .....	8
1.9 INSTALLATION PRECAUTIONS .....	8
2.1 ELECTRIC INSTALLATION .....	9
2.2 SETUP .....	9
2.2.2 CUSTOMIZING OPTIMA FEATURES .....	11
3.0 PHYSICAL LAYOUT .....	12
3.1 THE DISPLAY SCREEN .....	12
3.2 MENU KEYS .....	13
3.2.2 MAIN MENU FUNCTIONS .....	14
3.2.3 BALANCING .....	14
3.2.8 FUNCTION (SETUP) .....	16
4.0 HELP INFORMATION .....	17
5.0 POWER CLAMP .....	18
6.0 OPERATION OF THE BALANCER .....	19
6.1 CHECK LIST - INSPECTION .....	19
6.2 BALANCE SCREEN DESCRIPTION .....	20
6.2.1 WHEEL MOUNTING .....	21
6.2.2 STANDARD WHEELS (BACK CONE MOUNT) .....	21
6.2.3 CENTERING LIGHT-TRUCK WHEELS .....	21
6.3 SCAN MODE SELECTION .....	22
6.4 SPINNING THE WHEEL .....	23
6.5 SELECTING THE WEIGHT PLACEMENT .....	23
6.6 CORRECTION OF THE IMBALANCE .....	24
6.6.1 PROCEDURE WHEN SCANNER FAILS TO ACQUIRE A VALID PROFILE .....	24
6.7 VERIFICATION OF THE RESULTS .....	24
6.8 VIBRATION PROBLEMS .....	25
7.0 SPOKE BALANCING MODE .....	25
8.0 OPTIMA PROCEDURES .....	26
8.1 SELECTING MODE .....	26
8.2 BEGIN DIAGNOSTIC RUN .....	26
8.3 PROFILING THE WHEEL .....	26
8.4 OPTIMA GEOMETRIC MATCHING .....	28
8.4 BARE RIM DIAGNOSIS .....	30
9.0 OPTILINE, BALANCING A SET OF WHEELS .....	31
9.1 OPTILINE CUSTOMER CALIBRATION .....	34
10.0 WEIGHT MANAGEMENT .....	36
11.0 USER CALIBRATION .....	39
12.0 EXPLANATION OF PROGRAM CODES .....	40
13.0 MAINTENANCE .....	42
14.0 TROUBLE SHOOTING .....	42





## 1.0 INTRODUCTION

Congratulations on purchasing the **BFH 1000** Series Computer Ride Diagnostic Wheel Balancer. This wheel balancer is designed for ease of operation, accuracy, reliability and speed. With proper maintenance and care your wheel balancer will provide many years of trouble-free operation.

### **BFH Ride Diagnostics Balancer - Precautions To Observe**

Your BFH 1000 Series Ride Diagnostics Balancer utilizes the latest in electronics and instrumentation technology, incorporating three separate scanning lasers along with an embedded computer (PC). Following the precautions listed below will help to ensure continuous and satisfactory operation of your unit.

- 1) Install the balancer on a dedicated power line in order to avoid electrical noise and power line fluctuations. Avoid power cord length greater than 15 feet.
- 2) The BFH1000 Series Ride Diagnostic Wheel Balancer utilizes red scanning lasers which actually create an image of the wheel being diagnosed. Install the balancer away from direct sunlight so that the laser beams can be detected by the scanner. Avoid placing high intensity lamps and infrared heaters near the BFH balancer.
- 3) Diagnose and balance only those wheels which fit within the specifications of the BFH Balancer:  
Manual mode **Rim Diameter** range is 8 - 30 inches.  
Automatic Laser Non-Touch mode **Rim Diameter** and Profile range is 14 - 26 inches.  
Maximum **Tire Diameter** in Manual or Automatic mode is 44 inches.  
**Rim Width** range in Manual or Automatic mode is 3 - 20 inches.

**IMPORTANT: The BFH Laser Scanners can accurately measure parameters and profiles on rims from 14 to 26 inches in diameter. For Scanner measurement, a MINIMUM distance is required from the cabinet to the rim edge. The Distance is measured using the standard distance gauge arm (SAPE).**

**For rims 14-18 inches in diameter the minimum is 56 mm (2.20 inches)**

**For rims 19-26 inches in diameter the minimum is 81 mm (3.19 inches)**

- 4) The BFH balancer is designed to properly scan the profile of existing rims. Extreme geometric combinations of rim diameter and flange offset can inhibit the proper viewing of the rim profile. These exceptional rims can be properly balanced by manually entering the distance, diameter, and width of the rim.
- 5) The wheel guard of the BFH1000 Series Ride Diagnostic Wheel Balancer also serves as the housing for one of the scanning lasers. Since the laser must remain stationary once the spin cycle begins, do not lean on or otherwise disturb the wheel guard until the spin cycle has been completed.

Instructions on use, operational requirements and routine maintenance of the machine are covered in this manual.

This unit uses an open source Linux operating system for its user interface. This open source code is available for the cost of shipping and handling to owners of the BFH1000 Series Ride Diagnostic Wheel Balancer. Requests must be made to the attention of balancer product management at the Conway AR address listed on the back of this manual. Please include the owners name, address and unit serial number with all requests.

**STORE THIS MANUAL IN A SAFE PLACE FOR FUTURE REFERENCE.  
READ THIS MANUAL THOROUGHLY BEFORE USING THE MACHINE.**

---

## 1.1 SAFETY NOTICE

This manual is a part of the balancer product.

Read carefully all safety warnings and instructions of this manual since they provide important information concerning safety and maintenance. See Safety Chapter for safety information and warnings page I - IV.

## 1.2 BALANCER APPLICATION

*The John Bean BFH1000 Series Ride Diagnostic Wheel Balancer is intended to be used as a device to balance, diagnose and correct car, and light truck wheel vibration problems within the following range:*

Maximum tire diameter	:	44" (1117mm)
Maximum wheel diameter	:	30" (762mm)
Maximum wheel width	:	20" (381mm)
Maximum wheel weight	:	154 lbs (70 kg)

*This device is to be only used in the application for which it is specifically designed. Any other use shall be considered as improper and thus not reasonable.*

*The manufacturer shall not be considered liable for possible damages caused by improper, wrong or non reasonable use.*

## 1.3 BFH 1000 SPECIFICATIONS

Weight Imbalance Accuracy	.05 oz / 1 gram
Weight Placement Resolution	± .7 degrees
Weight Imbalance Resolution:	
Roundoff Mode	.25 oz / 5 grams
Non-Roundoff Mode	.05 oz / 1 gram
Max. Shaft Weight Capacity	154 lbs / 70 kg
Max. Tire Diameter	44" / 1117 mm
Rim Width Capacity	3.0"-20" / 76 mm - 508 mm
Max. Tire Width	21" / 530 mm
Rim Diameter Capacity	8"-30"/203mm-762mm
Balancing Cycle Time (normal mode)	20 seconds or less
Shaft Speed at calculation	>200 RPM
Electrical	230vac, 1ph, 50-60Hz, 3.2A
Required Work Area	64" x 64" (1626 x1626 mm)
Shipping Weight, complete	645 lbs/293kg
Shipping Dimensions	72"L X 73"W X 63"D (1829x1854x1600mm)
Machine Dimensions	64"h 64"w 64"d (1626x1626x1626mm)
Actual Weight with Accessories	550 lbs
Operating Temperature Range	32-122F / 0-50C

## 1.4 FEATURES

- Self test check with every power up cycle.
- Selectable car/light truck limit values
- Advanced Spoke count capability
- Rim-only diagnostics
- Rim cleaning brake control
- Flat spot detection
- On-board diagnostics for easy service issues
- Selectable default weight placement mode
- Weight Miser™ and Weight Wizard™ applications
- Advanced Help screens with illustrations
- Pre-programmed Error Codes indicate procedural errors or safety concerns.
- Fully Automatic All-Parameter Data Entry.
- Fully Automatic Rim/Tire Profiling.
- Fully Automatic Spoke/Split Weight Function for Hidden Weight Placement.
- Fully Automatic Left and Right Radial & Lateral Runout Measurements.
- Bare Rim Radial and Lateral Runout Measurement
- Tire Tread Depth Measurement.
- Hands-Free Power Clamping for Precise Wheel Placement.
- Fast Tire/Wheel Diagnostic System Time, Floor-to-Floor.
- Captured back spring eliminates having to handle the backing spring.
- Automatic recalculation if weight positions are changed. No need for re-spinning the wheel.
- Common 40 mm diameter mounting shaft.
- Easy-to-Read LCD Data Display Monitor.
- Dynamic and single weight Static capability.
- Stop-at-Top features simplifies weight imbalance location
- Automatic Weight Type Selection Based on Rim Profile, Indicated by Color Coded Icons
- Optima Balance feature for reducing weight required.
- Built-in spin counter for monitoring balancer productivity.
- Service code access to all Balancer electronic functions for fast, easy diagnosis.
- Operator selectable round-off mode.
- Weight Management Software, including *Weight Miser™* and *Weight Wizard™*
- Wheel pull index, option (standard on BFH 1000 Super)
- Wheel runout in multiple positions, optional feature (standard on BFH 1000 Super)

## 1.5 STANDARD ACCESSORIES

Standard accessories (Figures 1, and 2,) included with the BFH 1000 are:

- |   |             |                      |
|---|-------------|----------------------|
| 1 | EAM0005D40A | Weight - Calibration |
| 2 | EAC0060G02A | Flange - Cover, Hook |
| 3 | EAM0006G01A | Pin - Accessory      |
| 4 | 58839       | Weight Pliers        |
| 5 | EAA0247G21A | Caliper - Rim Width  |
| 6 | EAA0283D53A | Power Clamp Nut      |

### Power Clamp Nut Accessories, fig 2:

- |   |             |                      |
|---|-------------|----------------------|
| A | EAC0058D15A | Soft Protective Ring |
| B | EAC0058D07A | Cup - Large Pressure |
| D | EAM0005D54A | Plastic Sleeve       |
| E | EAC0058D08A | Small Pressure Disk  |

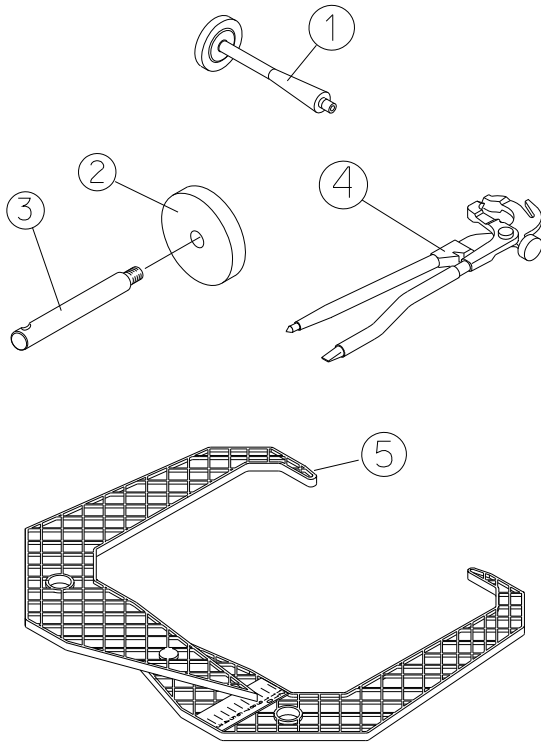

Figure 1- Standard Accessories

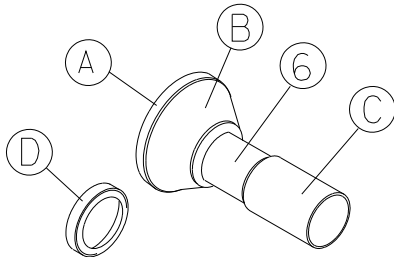
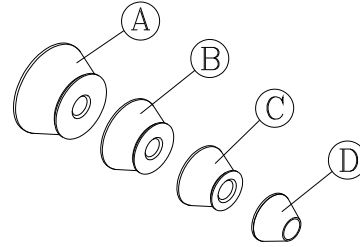

Figure 2 - Power Clamp Nut Accessories

## 1.6 OPTIONAL ACCESSORIES



4 PC Cone Kit, p/n EAK0221J60A, contains:

- |   |             |                              |
|---|-------------|------------------------------|
| A | EAM0003J08A | Cone, 85-132 mm / 3.3"-5.2"  |
| B | EAM0003J07A | Cone, 71-99 mm / 2.8"-3.9"   |
| C | EAM0003J06A | Cone, 56-84 mm / 2.2"-3.3"   |
| D | EAM0003J05A | Cone, 43-63 mm / 1.7" - 2.5" |

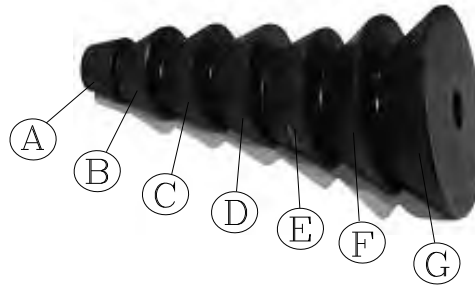

7PC Cone Kit, p/n EAK0221J31A, contains:

- |   |            |      |                |
|---|------------|------|----------------|
| A | EAM0003J64 | Cone | 1.70" TO 2.23" |
| B | EAM0003J65 | Cone | 2.03" TO 3.17" |
| C | EAM0003J66 | Cone | 2.38" TO 3.51" |
| D | EAM0003J67 | Cone | 2.74" TO 3.87" |
| E | EAM0003J68 | Cone | 3.08" TO 4.21" |
| F | EAM0003J69 | Cone | 3.42" TO 5.40" |
| G | EAM0003J70 | Cone | 4.21" TO 6.30" |

### 1.6.1 ADDITIONAL OPTIONAL ACCESSORIES



Wheel Lift - EAK0221J27A



Printer Kit - EAK0221J26A  
(printer may not be as shown)



Flange Plate Cart  
EAS2081J30A



Stick-on Weight Removal Tool  
EEHT300A



Flange Plates - Kit of 4  
EAK0221J22A

Figure 3

### PRE-INSTALLATION CONSIDERATIONS

#### 1.7 DIMENSIONS OF THE MACHINE

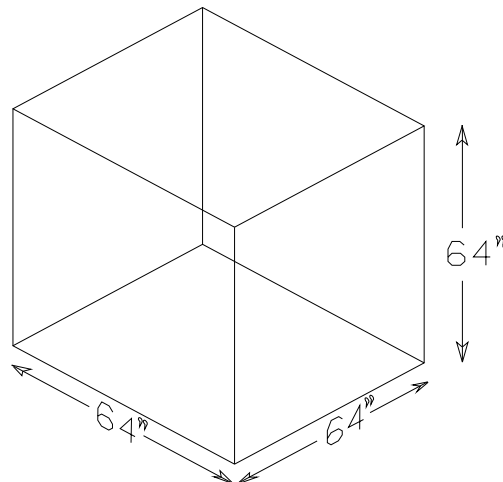

Figure 4 - Footprint Requirements

---

## 1.8 INSTALLATION AREA REQUIREMENTS

Make sure that from the operating position the user can see all of the machine and the surrounding area.

The operator should prevent non authorized persons and/or objects from entering the area which may create potential hazards.

The machine should be installed on a stable level floor. Do not install the machine on a uneven floor.

If the balancer is to be installed on a raised floor, the floor must have a capacity of at least 110lbs per sq ft. (5000 N/m<sup>2</sup> - 500 kg/m<sup>2</sup>).

It is not required to secure the machine to the floor but is recommended.

Install the machine in a dry, covered area.

The installation of the machine requires a working area of at least 64" x 64" (1626 x1626 mm). See Figure 3

## 1.9 INSTALLATION PRECAUTIONS

### **CAUTION! CAREFULLY REMOVE THE BALANCER FROM THE PALLET.**

Remove the hardware that secures the machine to the pallet and slide the balancer onto the floor where it is to be installed.

**THE UNIT IS HEAVY AND THE WEIGHT IS NOT EVENLY DISTRIBUTED.**

**DO NOT LIFT THE BALANCER BY THE SHAFT OR WHEEL GUARD FRAME.**

**DROPPING THE UNIT MAY CAUSE PERSONAL INJURY OR EQUIPMENT DAMAGE.**

## 2.0 INSTALL ACCESSORY PINS

**A.** Install the accessory pins (Figures 5a and 5b). Tighten firmly.

**B.** Install the Cone Accessory tray if installing a BFH 1000 Super Model. See Figure 5b.

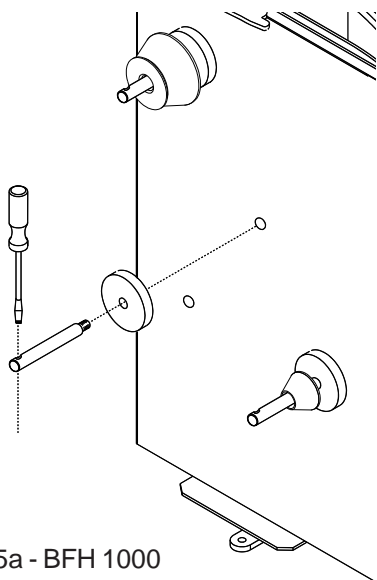

Figure 5a - BFH 1000

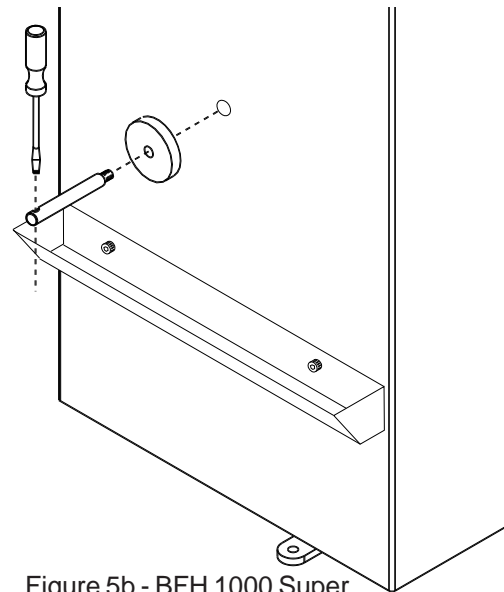

Figure 5b - BFH 1000 Super

**C.** Place accessories onto the accessory pins or place 7 cone set into tray.

## 2.1 ELECTRIC INSTALLATION

**ANY ELECTRICAL WIRING MUST BE PERFORMED BY LICENSED PERSONNEL.**

**ALL SERVICE MUST BE PERFORMED BY AN AUTHORIZED SERVICE TECHNICIAN.**

Check on the plate of the machine that the electrical specifications of the power source are the same as the machine. The machine uses 230VAC (+/- 15%), 50-60Hz, 1Ph, 3.2 Ampere.

**NOTE:**

**ANY ELECTRICAL OUTLET INSTALLATION MUST BE VERIFIED BY A LICENSED ELECTRICIAN BEFORE CONNECTING THE BALANCER.**

**NOTE:**

**THIS MACHINE PERFORMS A SELF-TEST ROUTINE ON START-UP. THERE WILL BE A DELAY OF SEVERAL MOMENTS BEFORE UNIT IS READY FOR OPERATION. ANY PROBLEMS DETECTED AT START-UP WILL RESULT IN THE DISPLAY OF AN ERROR CODE. PROBLEMS DETECTED DURING OPERATION ARE SAVED TO A LOG FILE WHICH CAN BE RETRIEVED FOR DIAGNOSIS BY A TECHNICIAN.**

## 2.2 SETUP

Every shop has different procedural requirements meaning each machine should be customized to the unique services performed at that location. Most attributes are set from the Main Function menu. A second “Optima” menu allows further customization

### 2.2.1 Customizing the System

**A.** Select the “Function” key (F1) from the “Welcome” menu. The Main Function setup screen appears as in Figure 6.

Figure 6

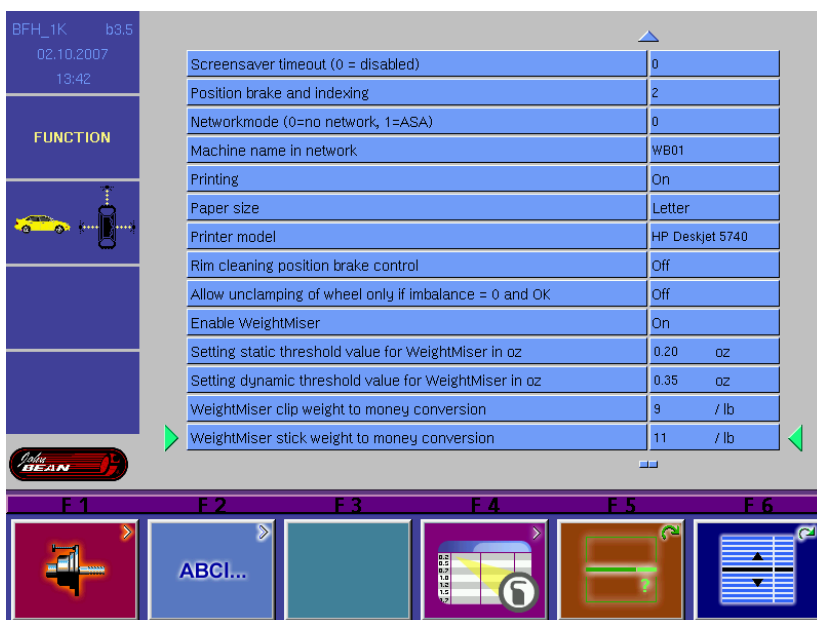

**B.** Press and hold the “F6” button and rotate the wheel to scroll up or down to the desired line item.

**C.** Press and hold the “F5” button and rotate the wheel to change selected topic to desired value or function.

**D.** When the desired features have been selected, save selections to permanent memory by selecting line item “3”. Hold the F5 button while rotating the shaft, enter a value of “1”, release to **Save to Permanent Memory**. See Figure 7a next page for complete menu listing.

**E.** Select the “ESC” button on the keyboard to return to the main screen.

Balancer operating mode (0 = manual, 1 = profiling, 2 = Optima)	2
Setting factory default modes of operation	0
Saving modes of operation in permanent memory	0
Language selection	English – uk
Volume of the audible signals	50
Resolution of the unbalance amount readings	Normal
Suppression of minor unbalance readings	On
Setting threshold value for unbalance suppression in oz	0.25 oz
Measurement unit of the unbalance amount readings	Ounces
Number of revolutions	10
Starting a measuring run by closing the wheel guard	On
Automatic braking when wheel guard is raised	On
Releasing of the power clamping device disabled	Off
Actuation direction of pedal for clamping/releasing	Raise
Date: Day	14.--
Date: Month	--.06.--
Date: Year	--.--.06
Time: Hour	02.--
Time: Minute	--.57
Counter ( total spins / spins with ok )	1793 93
Counter ( optimisation runs / clamping cycles )	6 116
Counter ( since last calibration / service )	18 25
Screensaver timeout (0 = disabled)	0
Position brake and indexing	2
Networkmode (0=no network, 1=ASA)	0
Machine name in network	WB01
Printing	On
Paper size	Letter
Printer model	HP Deskjet 5740
Rim cleaning position brake control	Off
Allow unclamping of wheel only if imbalance = 0 and OK	Off
Enable WeightMiser	On
Setting static threshold value for WeightMiser in oz	0.20 oz
Setting dynamic threshold value for WeightMiser in oz	0.35 oz
WeightMiser clip weight to money conversion	9 / lb
WeightMiser stick weight to money conversion	11 / lb

**Figure 7a - Complete Function Menu listing**



## 2.2.2 CUSTOMIZING OPTIMA FEATURES

- From the “Welcome” Screen or Balance Screen, select the “F6” Optima button.
- Select the “F3” Key to enter the menu used to set the limits required for an Optimization procedure.
- Set the values for measurement limits as required by the shop in lines 1-4 and 13-16. See Figure 7b

Wheel radial runout limit (1st harmonic)	0.028	inch
Wheel radial runout limit (Peak to Peak)	0.060	inch
Rim radial/lateral runout limit (1st harmonic)	0.032	inch
Rim radial/lateral runout limit (Peak to Peak)	0.050	inch
Tread Depth Limit	0.068	inch
Measurement of wheel data (0 = Only after clamping, 1 = Always)	0	
Rim runout measurement (0 = Limit exceeded, 1 = Always)	0	
Runout displayed units	inch	
Reset settings to factory defaults	0	
Saving settings in permanent memory	0	
Print on unclamping	0	
Weight Placement Default Selection	Clip-on	
Rim-only runout measurement (0 = Disabled, 1 = Enabled)	0	
Weight usage tracking (0 = Disabled, 1 = Enabled)	1	
Runout displayed units	inch	
Reset settings to factory defaults	0	
Saving settings in permanent memory	0	
Print on unclamping	0	
Weight Placement Default Selection	Clip-on	
Rim-only runout measurement (0 = Disabled, 1 = Enabled)	0	
Weight usage tracking (0 = Disabled, 1 = Enabled)	1	
Advanced options (0 = Disabled, 1 = Enabled)	1	
Advanced spoke detection (0 = Disabled, 1 = Enabled)	0	
Flat spot detection (0 = Disabled, 1 = Enabled)	0	
Wheel runout in multiple positions (0 = Disabled, 1 = Enabled)	0	
Multiple runout harmonic display (0 = Disabled, 1 = Enabled)	0	

Figure 7b

**D.** Line Item 5 allows the user to select the option of making a profile measurement with each spin or only after a clamping cycle. Select option “0” (only after clamping) allows a quicker floor to floor time. The unit will then profile the next wheel assembly after it is clamped. It considers each subsequent spin to be a check spin using the same parameters and profile.

**E.** Advanced Options selection will activate the “Optiline” feature available with the BFH1000 Super. See page 28 for Operation details.

**F.** Advanced Spoke Detection will enable a multiple pass spoke counter. When enabled the spoke counter will attempt to detect spoke in mutple locations.

**G.** Enable or disable Flat Spot Detection. This feature will detect an abnormally worn area of a tire.

**H.** Measure Wheel runout in multiple positions if only a wheel is mounted for bent rim diagnosis.

**I.** Save the values selected by scrolling down to line item 8, (Save to Memory) while rotating the shaft, enter a value of “1”, release to **Save to Permanent Memory**

**NOTE: It is recommended that default values be used until which time the users feel they can customize the menus for desired results.**



Figure 8

### 3.0 Physical Layout.

Refer to Figure 8. - Functional description of the unit:

1. The screen
  2. Input panel
  3. Gauge arm
  4. Stub shaft with power clamp nut
  5. Brake and clamp control pedal
  6. Weight compartments
  7. Storage areas for cones or clamping devices
  8. Tilting frame and hood guard
  9. Outer scanner
  10. Rear scanner
  11. Inner scanner
  12. Main Power switch (ON/OFF), rear
- NOTE: shown with optional wheel lift, not included

### 3.1 The Display Screen

See Figure 9, Screen with display fields

- 1-5 Information fields
- 6 Menu fields and Function descriptors.
- 7 Display field of screen  
The screen reads out inputs, helpful information, all measured data and error codes.

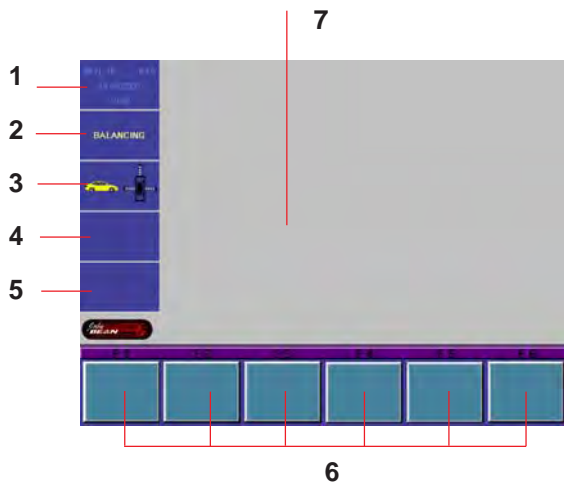

Figure 9

#### Detailed description of display fields

The screen is subdivided into various display fields, each of which is associated with a certain type of information.

#### Information fields

- 1 Number of the installed program version  
Machine name  
Date and time
- 2 Selected Menu name
- 3 Selected profiling mode
- 4 Electrical compensation
- 5 Error codes

#### 6 Menu fields

Icons illustrating special features or functions are viewed in the six menu fields. Under every menu field is the associated menu "F key" which is used to call the feature illustrated.

#### 7 Display field

Wheel type and rim dimensions  
Balancing modes  
Amount of unbalance  
Direction of orientation and correction position  
Optima procedures  
Function and Setup Menus  
Other Graphical information

## 3.2 Menu Keys

### 3.2.1 Description of Menu Keys

The assignment of the menu keys **F1** to **F6** is shown in the menu fields above the relative keys on the screen. The menu keys have different functions and initiate different actions, depending on the program step.

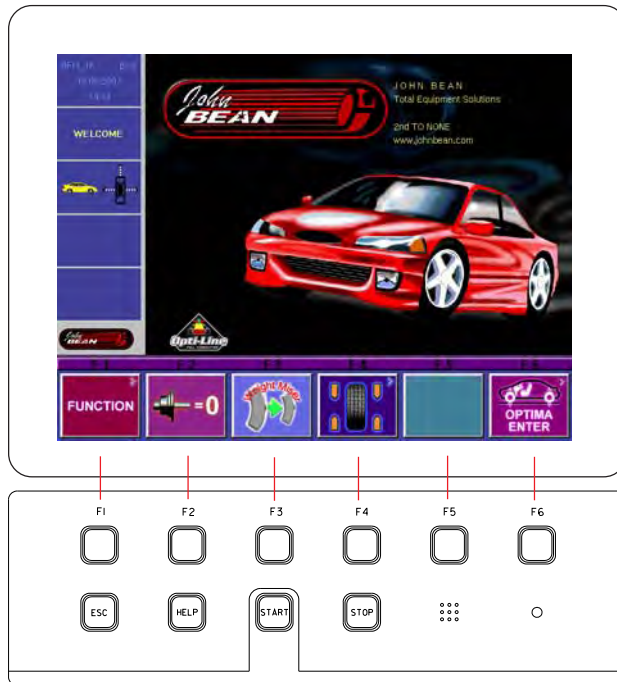

Figure 10

- Keys without a symbol in the upper right-hand corner or at the edge initiate an action immediately, such as F2 on the main screen means to perform a compensation process. See Figure 10.

- Keys with one or more symbols in the upper right-hand corner of the menu field or at the edges initiate various actions:

**a** - Press key to access a sub-menu, e.g. key F4 Balancing.

**b** - Press and hold key down while rotating wheel at same time, e.g. key F11 Number of spokes.

**c** - Press key to toggle between two options or states, e.g. key F9 Static / dynamic unbalance.

**d** - Press key to toggle between several options or states, e.g. key F21 Weight position for correction plane.



a



b



c



d

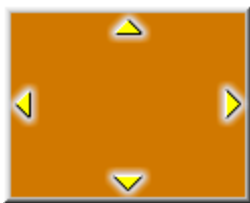

e



f

**e** - Toggle switch (4 functions): Press edge of key to carry out the highlighted action, e.g. key F32 Character set: move the cursor in the character set to the left, to the right, up or down.

**f** - Toggle switch (2 functions): Press key on top or bottom to select the highlighted function, e.g. key F8 Precision reading of unbalance and mode select.



Icon 1

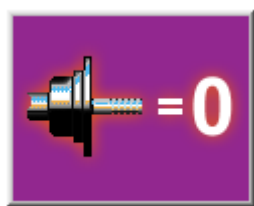

Icon 2

### 3.2.2 MAIN MENU FUNCTIONS

Icon 1 Change to the Function screen

Icon 2 Perform adapter compensation run

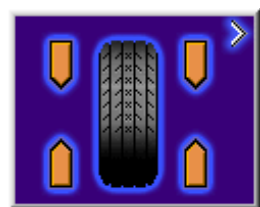

Icon 3



Icon 4

Icon 3 Change to the Balancing screen

Icon 4 Change to the OPTIMIZATION MENU

### 3.2.3 BALANCING

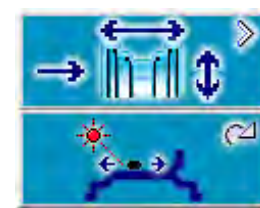

Icon 5



Icon 6

Icon 5 Toggle switch, two functions:

Pressed on top:  
View and/or edit Data Input (wheel parameters)

Pressed on bottom:  
Move the laser position pointer to the desired location. Button must be held down as the shaft is rotated. (only when stick-on weights are selected)



Icon 7a



Icon 7b

Icon 6 Toggle switch, two functions; reading only as long as the key is pressed (quick reading):

Pressed on top:  
Precision reading of unbalance, no suppression of minor unbalance readings.

Pressed on bottom:  
Toggles through possible placement locations of weight placement for conventional balancing run.



Icon 8



Icon 9

Icons 7a and 7b Select static unbalance or Select dynamic unbalance

Icon 8 Number of spokes has been selected and entered.

Icon 9 Number of spokes has not been detected and must be entered manually if required. Hold the F key while rotating the shaft until the desired value is displayed.



Icon 10

Icon 10 Wheel with 6 spokes selected

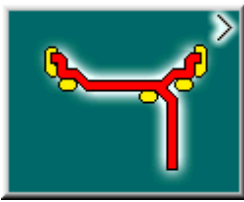

Icon 11



Icon 12

### 3.2.4 RIM DATA INPUT

**Icon 11** Change to the WEIGHT PLACEMENT (mode) screen.

**Icon 12** Change to the RIM TYPE screen



Icon 13

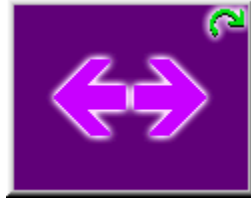

Icon 14

**Icon 13** Hold key down and enter the distance rim/machine by rotating the wheel

**Icon 14** Hold key down and enter the rim width by rotating the wheel



Icon 15

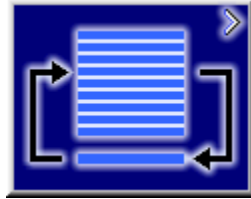

Icon 16

**Icon 15** Hold key down and enter rim diameter by rotating the wheel

**Icon 16** Change to the Stored Parameter menu. Must be in the "Manual" parameter mode

### 3.2.5 PROFILES SCREEN, STORED PARAMETERS



Icon 17



Icon 18

**Icon 17** Select or store a wheel profile. Hold key down and select copy or store by rotating the wheel.

**Icon 18** Store a parameter. Select memory location to store current wheel profile for later retrieval (yellow arrow). Select "OK" to enter the values currently in use to a stored location.



Icon 19



Icon 20

**Icon 19** Copy a stored parameter. Select memory location for retrieval (yellow arrow). Select "OK" to enter the values stored for use in the next balance run.

**Icon 20** Accept or enter the selected parameters.

### 3.2.6 FUNCTION MENU



Icon 21



Icon 22

**Icon 21** From the Main Menu, Select FUNCTION to access screens used to prepare the unit for desired operation.

**Icon 22** Change to the screen USER CALIBRATION, see Maintenance chapter for user calibration procedures.



Icon 23

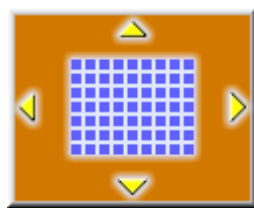

Icon 24

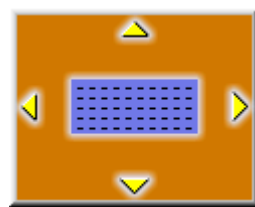

Icon 25

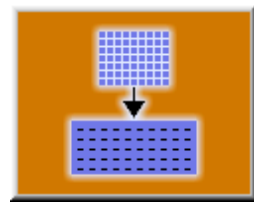

Icon 26



Icon 27

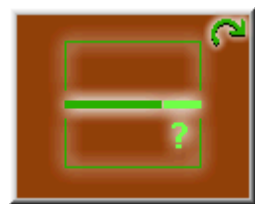

Icon 28



Icon 29

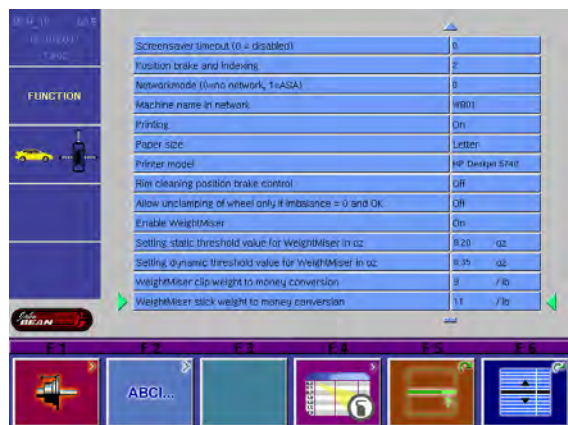

Figure 11

### 3.2.7 TEXT EDITOR

**Icon 23** Change to the screen TEXT EDITOR

**Icon 24** Toggle key, four functions: Move the cursor within the character set (right, left, up, down) to the desired character.

**Icon 25** Toggle key, four functions: Move the cursor within the text field (right, left, up, down) to the desired text box location

**Icon 26** Transfer characters from the character set to the text field

**Icon 27** Save text

### 3.2.8 FUNCTION (SETUP)

**Icon 28** Change selected topic to desired value or function.

**Icon 29** Hold button and rotate the wheel to scroll up or down to the desired line item.

Setup screen illustration. When desired features have been selected, save to permanent memory by selecting line item "3", Save to Permanent memory, enter a value of "1" with the F5 button while rotating the shaft. Release button to save. Select the "ESC" button to return to the main screen. See Figure 11.

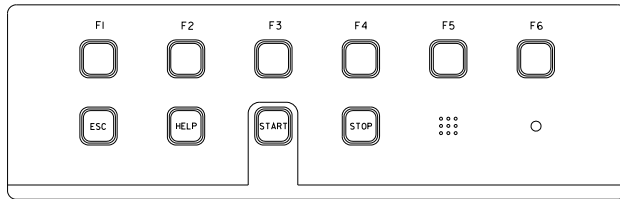

Figure 12

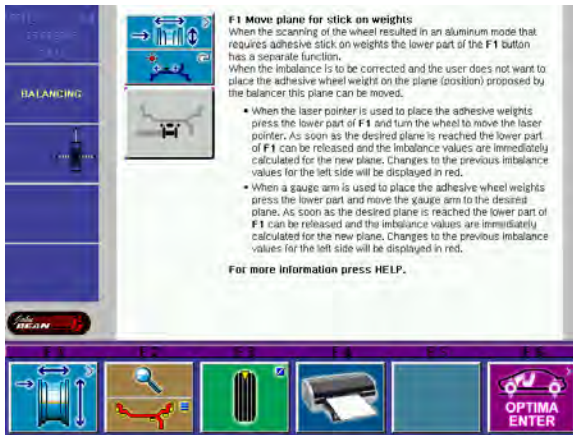

Figure 13

## 4.0 Help information

Help information explains the current action and, in the case of an error code, provides hints for remedy. See Figure 12.

### Display help information

- Press the HELP key ( See Figure 13)
- The first screen with help information appears, e. g. to the screen RIM DATA INPUT.
- Press the HELP key once more to display any additional screen with information.

### Quit help information

- Press the ESC key

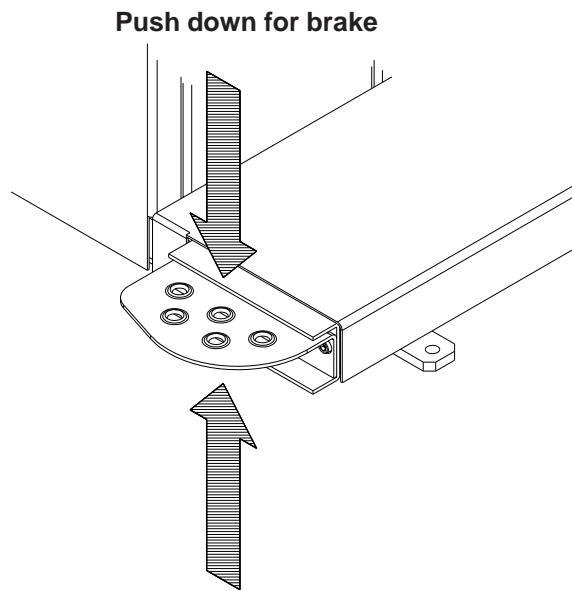

**Lift up for power clamp operation**  
Figure 14

## 5.0 POWER CLAMP

### 5.1 POWER CLAMP PEDAL

#### Shaft Lock

The main shaft is locked when the pedal is **depressed**. This holds the wheel in the correction position for correct fitting of the correction weights. See Figure 14.

This lock is designed only to facilitate orientation of the wheel and must not be used for braking the main shaft.

#### Power Clamp Operation.

Lift upward to engage the power clamp jaws when the lock nut is placed on the shaft.

Lift upward again to release the clamp nut.

**NOTE:** The first time the unit is operated after power-up, make sure the power clamp engaging jaws are in the outer most position and ready for use. An Error of “E14” may result if the unit cannot accurately determine the clamping jaw position. Simple press “ESC” to continue, lift the pedal again to cycle and the power clamp will learn its new position. See Figures 15 and 16.

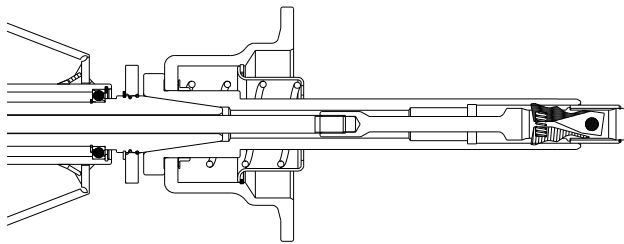

**Power Clamp with jaws all the way OUT**

Figure 15

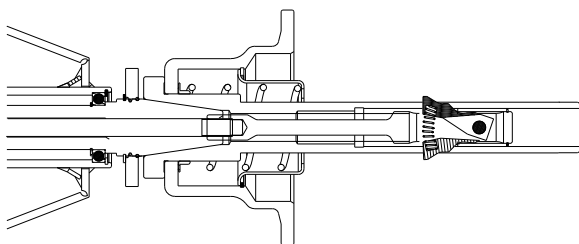

**Power Clamp with jaws all the way IN**

Figure 16



## 6.0 OPERATION OF THE BALANCER

**WARNING:** For operator safety please read and follow the precautions outlined on pages I thru III of this manual.

**NOTE:** READ ALL INSTRUCTIONS BEFORE PROCEEDING WITH OPERATION OF THE BALANCER.

All balancer functions are input into the main computer through the large easy to read touch panel. Although each wheel tire assembly differ in some ways all balancing jobs require basically the same procedure. The order of events to take place are:

1. Inspection of the wheel/tire assembly
2. Mounting wheel onto shaft
3. Scanner entry of wheel profile
4. Applying the recommended weight
5. Optima Mode diagnosis if required, or Check spin if desired
6. Dismounting the wheel

The following operation instructions will follow the basic outline above.

### 6.1 CHECK LIST - INSPECTION

#### Observe Before Balancing Wheel

1. Check for proper air pressure. If not correct, inflate to correct pressure.
2. Check for any foreign material inside tire. If present, remove before balancing tire.  
*WATER IS FOREIGN MATERIAL!*
3. Remove old weights — old weights may be improper value or in wrong location.
4. Be sure tire and wheel are free of excessive dirt, rust and large stones. Use wire brush on back side of wheel if necessary.

Figure 17



## 6.2 BALANCE SCREEN DESCRIPTION

Refer to Figure 18a below for an example of a typical balance screen. The wheel displayed has been profiled as a rim which will accept a clip weight on the left side and a stick-on weight on the right side. An *orange* weight is the correct clip-on selection for this application. The Clip weight will be placed at top dead center when the arrows indicate green. The stick-on weight is placed as indicated by the laser pointer. The operator selects the desired mode as indicated by the yellow weight icons, such as clip-stick as shown in the example below. Subsequent wheels will use the same mode. Tread depth is measured to be within tolerance in the example.

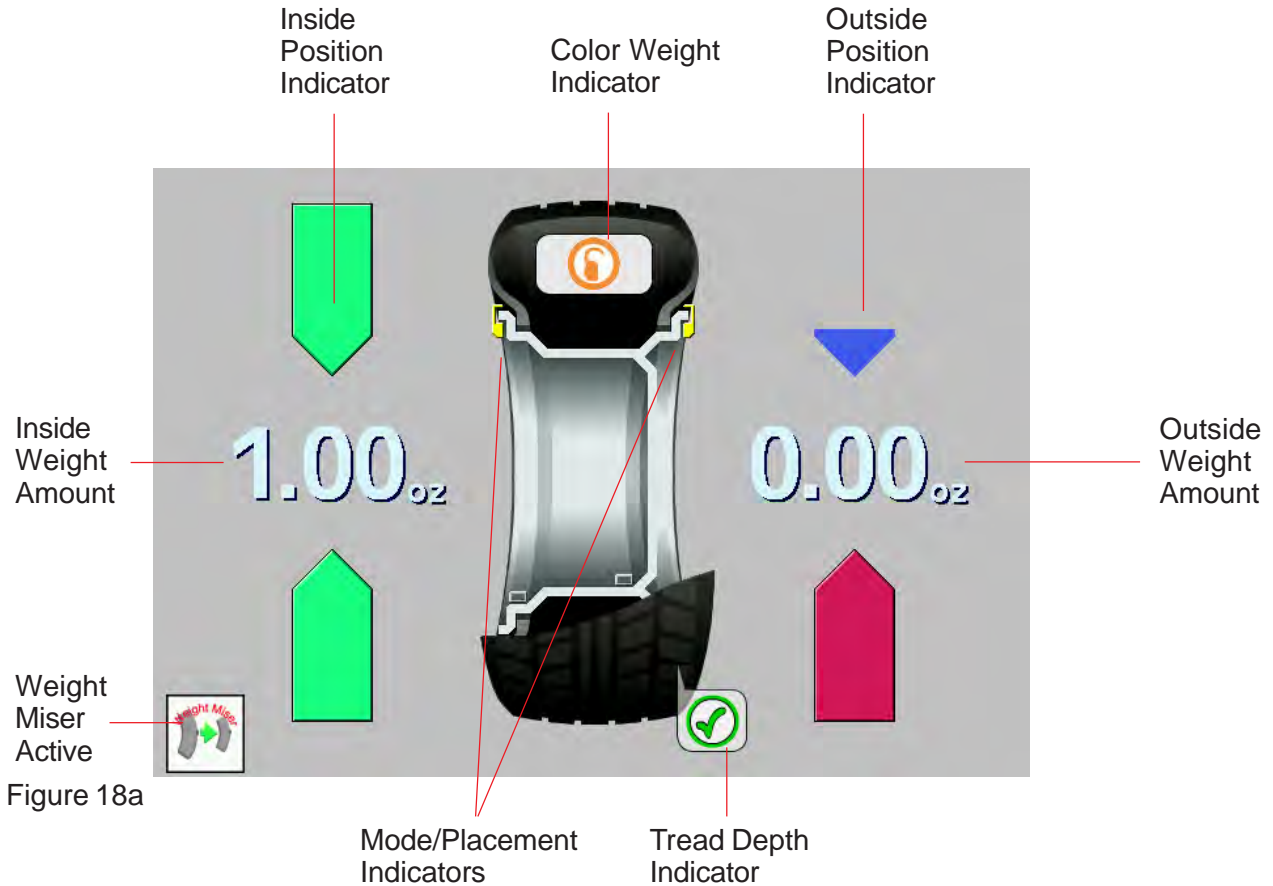

Figure 18a



Figure 18b - Color Weight Selections



Figure 18c - Tread Depth Indicators

## Begin Balance procedures

From the Main Menu, select "F4" to enter the balance mode of operation.



### 6.2.1 WHEEL MOUNTING

Most standard wheels and many alloy wheels have accurately machined center holes, and they should be mounted with center cones. Accurate balancing depends on accurate mounting of the wheel and correct seating of the cone in the pilot hole. Insure that the wheel is centered on the shaft exactly as it will be mounted to the vehicle.

Before starting any balancing procedure it is very important that the wheel is mounted on the machine with the proper adaptors. An incorrect centering of the wheel will result in considerable imbalance.

There are many types of wheels and John Bean supplies adaptors of high quality and durability for the large majority. However if you meet special wheels which may require a specific adaptor, call your authorized John Bean distributor.

Rims may be divided into these major groups:

1. *Car rims with a true center hole.*
2. *Car rims without a center hole.*
3. *Car rims with an untrue center hole.*
4. *Light truck rims.*

### 6.2.2 STANDARD WHEELS (BACK CONE MOUNT)

Mount the wheel as detailed below in Figure 19a.

1. Mount proper cone against spring plate.
2. Mount wheel on shaft in the same manner as you would on the car.
3. Mount the Power Clamp nut along with proper pressure cup.
4. To operate the power clamp, lift the foot pedal to engage the clamp. Lift pedal again to release the nut.

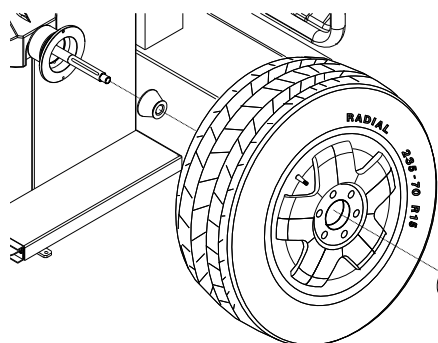

Figure 19a - Standard rear cone mount

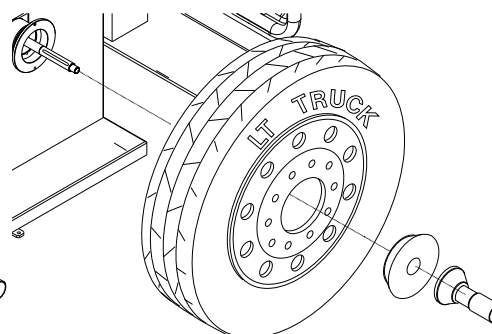

Figure 19b - Truck cone - outside cone mount

### 6.2.3 CENTERING LIGHT-TRUCK WHEELS

Install the wheel, using the front cone method, See Figure 19b.

An optional offset spacer may be required for some light truck wheels and reverse-offset wheels that must be moved away from the balancer mounting flange. The extension adaptor is often used with the 5-1/4 inch diameter light truck cone.



**WARNING - HOLD THE POWER CLAMP NUT BY THE PLASTIC END CAP ONLY!! THE POWER CLAMP WILL NOT STOP UNTIL THE WHEEL IS SECURE AGAINST THE FLANGE. SEVERE PERSONAL INJURY WILL OCCUR IF FINGERS OR HAND IS PINCHED BETWEEN THE NUT, WHEEL OR FLANGE.**



### 6.3 SCAN MODE SELECTION

The BFH 1000 can be operated in 2 automatic scan modes and one manual mode. Default factory setting is the OPTIMA mode. The BFH 1000 can easily be set to PROFILING mode if OPTIMA functionality is not required or wanted for every balance job. To access PROFILING OR OPTIMA modes, depress the F6 key for approximately 3 seconds. The mode will change with each depression. Pressing the F6 key momentarily activates the OPTIMA procedure.

**PROFILING** mode is used when wheels only need to be balanced and the operator does not want to monitor the ride performance of the wheel and includes:

- Rim profiling to get rim data including ALU wheel weight position
- Spoke count when ALU mode is detected
- Balancing

The PROFILING mode is indicated by the following symbol that is visible in information box 3 in the left upper corner of the screen.

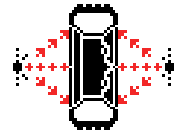

**OPTIMA** mode is used for checking the ride performance of the wheel and includes:

- Rim profiling to get rim data including ALU wheel weight position
- Spoke count when ALU mode is detected
- Balancing
- Radial tire run out
- Left radial rim run out
- Left lateral rim run out
- Right lateral rim run out
- Right radial rim run out

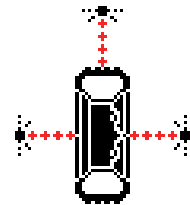

The OPTIMA mode is indicated by the following symbol that is visible in information box 3 in the left upper corner of the screen.

**Manual** Parameter Entry - Read the rim diameter marked on the sidewall of the tire (Figure 20b). Enter the stated rim diameter by pressing and holding the diameter button and rotating the wheel assembly until the desired value is displayed.

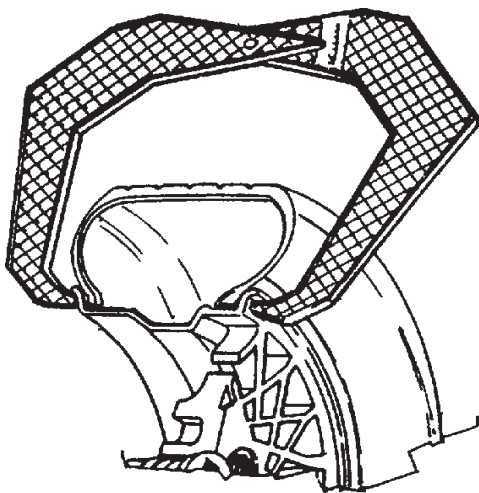

Figure 20a

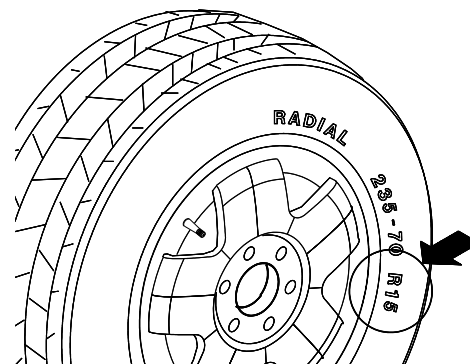

Figure 20b

## 6.4 SPINNING THE WHEEL

**NOTE:** Before spinning the wheel, make sure proper eye protection is worn by all personnel in the vicinity of the balancer.

**A.** Spin the wheel by lowering the wheel guard. If auto-spin is not activated press “Start” to begin balancer run. When the balancing cycle is complete the wheel will stop automatically and the imbalance values will appear on the screen.

**B.** In the Standard or Profiling Mode, the machine first measures the amount of imbalance at a higher rpm, the speed is then reduced and the profilers measure the rim distance, wheel diameter and rim width. Spokes are counted during this action as well.

If the unit is operating in the Optima mode the unit will measure the above plus will measure the amount of rim radial and lateral runout and wheel assembly radial runout. If the software has determined a clip-on weight can be used on the right rim edge, then the right radial and lateral runout are measured.

After runout values along with the imbalance data are collected and stored, the BFH1000 then determines if an “Optimization” procedure will benefit this assembly. Thresholds can be set in the Optima setup menu to determine the “break” point.

## 6.5 SELECTING THE WEIGHT PLACEMENT



Figure 21

**A. 2-Plane** - Choose the appropriate balancing mode for the wheel. To select the various 2-plane weight placement modes press the Mode button (Lower part of F2) until the placement graphic indicates desired corrective weight placement position. Press and hold the lower button for 3 seconds goes directly to clip-clip without having to prompt through all the modes. Fig 21

**B. Select STATIC** mode. Use a single corrective weight placed in the center or inner edge of rim. Select Static by pressing the “F3” key on the balancing screen. Pressing “F3” again will toggle operation back to Dynamic 2-plane operation.

**NOTE:** If in the “clip-weight static mode”, the weight placement position will be at top dead center. While in “stick-on mode”, weights will be placed at bottom center where the laser indicates.



F2



Static

---

## 6.6 CORRECTION OF THE IMBALANCE

A. The wheel assembly automatically stops near the right weight correction plane.

**NOTE:** Automatic plane braking can be selected from the main function setup menu. Factory default is right plane (2), select a value of “1” for braking on the left plane, “0” for none.

B. Read the imbalance value of the right side. Values are displayed in ounces but can be displayed in grams if required and are automatically rounded to the nearest commercial wheel weight.

C. Place the amount of weight called for. Use the foot operated shaft lock to stabilize the shaft during weight placement if required.

**NOTE:** When balancing in the Clip-on mode, the “Color Weight” graphic indicated is the “best selection” for the laser profile of the wheel in service.

D. Press “Start” with the hood up to rotate the assembly to the left or inner correction plane.

E. Place the amount of weight called for. Use the foot operated shaft lock to stabilize the shaft during weight placement if required.



### 6.6.1 PROCEDURE WHEN SCANNER FAILS TO ACQUIRE A VALID PROFILE

If data for distance, diameter or width are missing it is not possible to balance a wheel since the balancer does not have proper wheel data.

The unit will display the data (distance / diameter / width and weight placement mode) of the last wheel measured in RED color to indicate those data fields which might not be correct.

In the event of chasing weights, view the “Parameter” Screen and observe the values. If any parameter is displayed in red, it has not been validated and the value must be manually entered to recalculate the proper correction values. To change a value in the Parameter or Optima mode, the corresponding button must be depressed twice. Modify the data by pushing and holding F3, F4 or F5 and turning the wheel until the desired value is displayed.

After the wheel has been unclamped from the balancer, the balancer will switch back to the previous mode for the next wheel assembly.

## 6.7 VERIFICATION OF THE RESULTS

Lower the wheel guard to spin the wheel again and check that the readout is “0.00” “0.00” If a residual imbalance is displayed: Reference Graphic 1 next page for diagnostics explanation below.

A. Check the rim parameters, if entered value is incorrect, correct as needed. Imbalance values will be automatically re-computed.

B. Check if the balancing mode selected is the most appropriate. If not, choose the right mode and re-spin.

C. The wheel weight could have been placed at a wrong position. To check this, position the wheel at the correction position for the outer plane. If the wheel weight previously attached is in sector ‘L’ or ‘R’ ( Graphic 1, page 22), move the wheel weight up about 1” (2.54cm).

If the wheel weight is in sector ‘D’ cut a piece of the wheel weight of an approximate value corresponding to the value shown on the right display, or replace the wheel weight with a lighter one.

If the wheel weight is in sector ‘U’ add a weight of value indicated by the display or replace the wheel weight with a heavier one. Repeat the same operation for the inner plane.

**NOTE:** If this situation is repeated, your machine may be out of calibration and a calibration operation might be required, contact a service representative for re-calibration.

**D.** If an *ALU* function was selected ensure the wheel weights have been placed in accordance to the program chosen.

**E.** Check that the wheel is not slipping against the backing collar.

**F.** Check that the wheel and adaptors are clean.

Graphic 1.

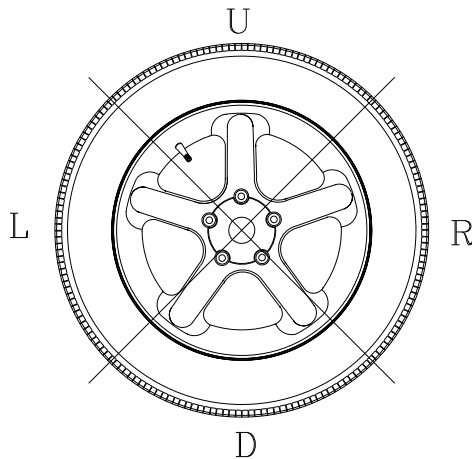

## 6.8 VIBRATION PROBLEMS

If vibration is still present after balancing, check the following possible sources of vibration:

1. Stones caught in the tire tread.
2. Tire slippage on the wheel.
3. Incorrectly mounted wheel.
4. Imbalanced wheel covers.
5. Excessive radial or lateral runout in the tire or wheel.
6. Damaged wheel bolt holes.
7. Worn universal joints.
8. Imbalanced brake rotors or drums.
9. Worn or damaged balancer accessories.

## 7.0 SPOKE BALANCING MODE

A standard dynamic balance in *ALU* mode places compensation weight in two planes, inner and outer, at the bottom dead center for each plane of calculated imbalance. Sometimes the outside weight placement may be unsightly on a custom wheel. The Spoke Mode is designed to “hide” outer plane corrective weight by placing the required weight behind selected spokes in order to retain the esthetic appeal of the wheel.

1. Press the Spoke button, F5.
2. Outer weights will be divided. Weights may not be equal depending on the spoke positions relative to the imbalance position.
3. Place stick-on weights where indicated by the laser pointer.
4. Perform a check spin if desired.

**NOTE:** Stick-on weight position can be “tweaked” by depressing the lower part of “F1” while rotating the shaft fore or aft until the laser locates in the desired position. Inner or Outer placement indicator must be “in the green” before depressing the button.



Figure 22



Figure 23



Figure 24

## 8.0 Optima Procedures

The **Optima Mode** is a feature which improves wheel running conditions through enhanced optimization capabilities while improving wheel balancer productivity without the need to measure the radial force.

In the Optima mode the following parameters are measured in one measuring run only:

- Radial and lateral rim run out for the left side is measured by non touch devices.
- Radial and lateral rim run out for the right side is measured by non touch devices.
- Bead seat radial run out (if required) on the rim is measured by a non touch device.
- Radial tire run out is measured by a non touch device.

Subsequent to balancing results and run out measurement geometric matching of tire to rim is performed to improve ride performance. The possible improvement of ride performance is displayed in percent in the Optima Results Screen.

### 8.1 Selecting Mode

Select the desired profiling mode for the balance run. Press and hold the “F6” Optima Softkey for 3 seconds to toggle between **Profiling** mode and full Optima mode. See “F6” Key in Figure 22.

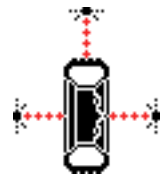

Full Optima

The corresponding indicator icon will appear in box 3 on the Welcome screen to indicate the current mode.



Profiling

### 8.2 Begin Diagnostic Run

From the “Welcome” screen, Figure 22, select the “F4” Softkey to begin the Optima procedure.



Press “Start”, see Figure 23.

### Imbalance Calculations

The Wheel/tire imbalance values are calculated first at the higher RPM.

The assembly then slows for the Profiling mode.

### 8.3 Profiling the wheel

The laser scanners are activated next which create a virtual profile of both the inner and outer rim. Rim distance, diameter and rim width are determined.

Spokes are counted during the initial scan process for use during the correction steps if required, Figure 24. The inner rim radial and lateral runout is measured next.





Figure 25

If the profile scan determines the rim to be a steel or stamped rim, the outer rim radial and lateral runout is measured. See Figure 25

The wheel assembly radial runout is measured.

Calculations are made with all input data and stored for display when recalled.



Figure 26

If Optima thresholds have been exceeded the Optima Diagnostics screen will indicate the assembly radial runout amount and make a recommendation of performing a full Optima compensation procedure.

Several other ride diagnostics variables are determined and displayed for reference. See Figure 26.

- Wheel radial runout
- Rim radial runout
- Rim Lateral runout
- The proportion of rim and tire runout

The amount of static imbalance influence

The amount of correction possible by a geometric correction.



Figure 27

A Warning note if an excessive amount of radial runout is detected on the wheel assembly. Press the “HELP” softkey to read about suggestions to remedy the problem.

Select softkey “F2” to display the assembly radial runout and the rim radial runout at the same time. Fig.27.

The graphs indicate where the runout is relative to a radial position. As the assembly is rotated, note the location of high or low spots. The Geometric correction procedure uses this information for matching.

Select the Softkey “F3” to display rim radial and lateral runout graphically at the same time.

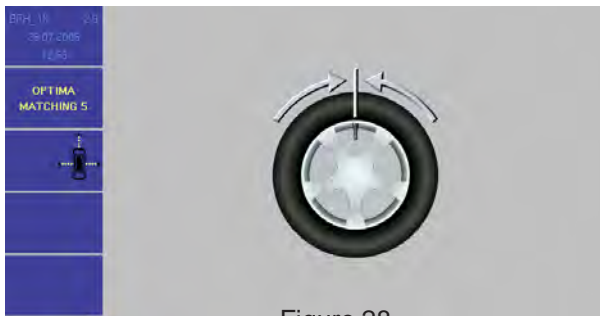

Figure 28

### 8.4 Optima Geometric Matching

Select softkey "F5" to continue to the matching process if desired. See Figure 27.

Rotate the assembly so the valve stem is located at top dead center. Press "F6", to continue. See Figure 28.



Figure 29

Rotate the assembly so the arrows are both GREEN, as shown in Figure 29. Mark the tire at top dead center. Select "F6" to continue.



Figure 30

Remove the Wheel assembly from the balancer and break the bead using a tire changer. Rotate the tire on the rim so the mark and valve stem are lined up. See Figure 30.

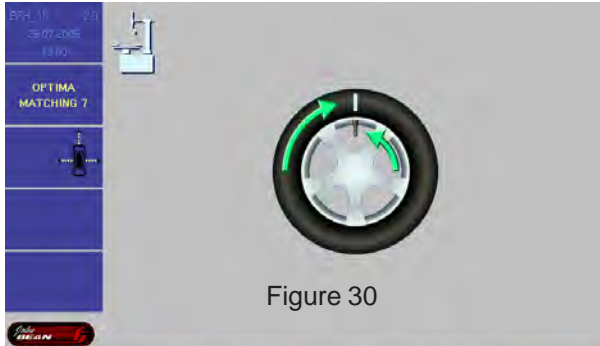

Figure 31

Reinflate the tire to specifications.

Mount the assembly back onto the balancer as before.

Select "Start" See Figure 31.





Figure 32

The unit will re-profile and recalculate based on the new tire-rim combination. See Figure 32.



Figure 33

Corrective weight amounts and locations will be displayed. If the assembly again exceeded the threshold, the Optima screen would be displayed with additional suggestions. See Figure 33.

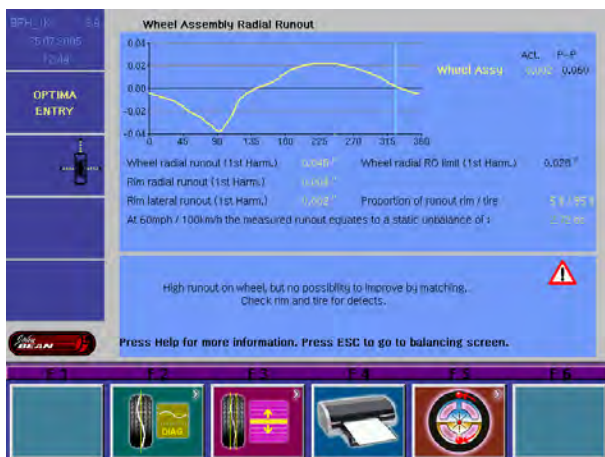

Figure 34

If the assembly passed this time the Optima display would say "OK". If a problem is detected, the information is displayed on the diagnostics screen. See Figure 34, the example indicated a high runout on the wheel, Optima procedures are not possible.

The static equivalent imbalance is shown. A static equivalent indicates how much static imbalance it would take to equal the out of round condition of this tire.

If at any time the process is in question, press the “HELP” key on the keyboard for more information regarding the current process. See Figure 35.

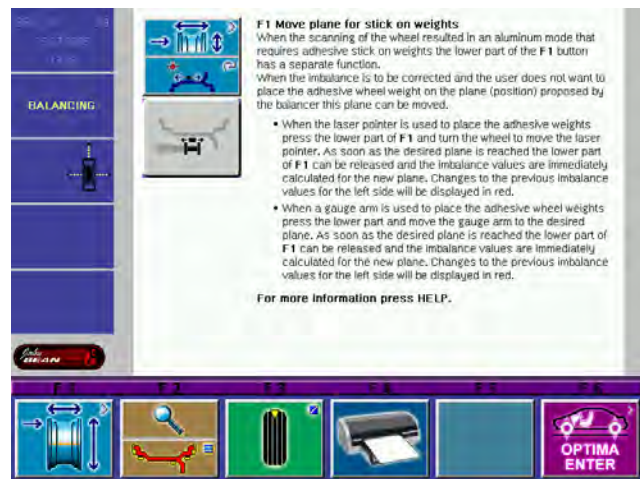

Figure 35

### 8.4 Bare Rim Diagnosis

The BFH 1000 has the ability to automatically detect the presence of a bare rim when mounted. The unit will then measure both bead seat surfaces for radial runout. The unit will then display a report with a graphical display of surface irregularities and the values of runout. See Figure 36



Figure 36

Press cancel to prompt to the weight placement screen to view the amount of imbalance and correct if desired. See Figure 37.



Figure 37

## 9.0 OptiLine, Balancing a Set of Wheels

The “OptiLine” advanced feature provides a solution to a pull problem on a car that cannot be fixed by a wheel aligner but is related to the conicity of the tire.

**NOTE: This feature is not available as standard with the BFH1000 wheel balancer but is to be purchased in addition.**

On the BFH 1000 wheel balancer the outer tire surface is scanned by the lasers and the result calculated into a pull index. After 4 wheels are measured the balancer proposes the best position for each wheel on the car in a way that the wheel pull index on each axle is compensated or minimized.

The feature “OptiLine” is selected in the BFH 1000 “Optima” screen by pushing the F6 button. See Figures 38 and 39

When the “OptiLine” mode is selected the pictorial in the status bar changes

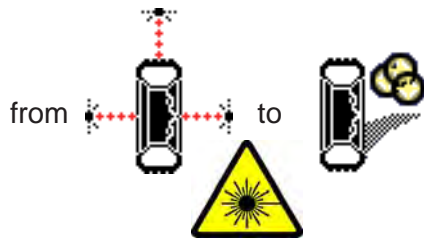

Depending on the measurements, the BALANCING screen or the ENTRY screen will come up. After the wheel has been matched and / or the imbalance has been corrected, the wheel is unclamped from the balancer and the SET OF WHEELS 1 screen will come up. Shown in Figure x with a RED tag. Fig. 40

The wheel can now be entered to the set by pushing either F3, F4 or F5. A tag in the color of the wheel on the screen is attached to the valve stem to identify the wheel clearly after all wheels in the set have been measured.



Figure 38

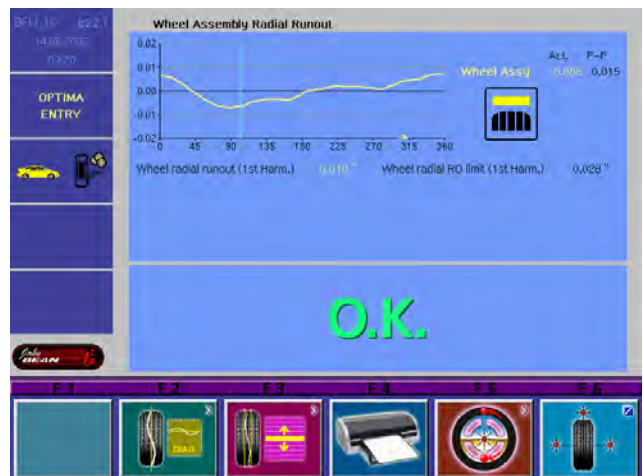

Figure 39

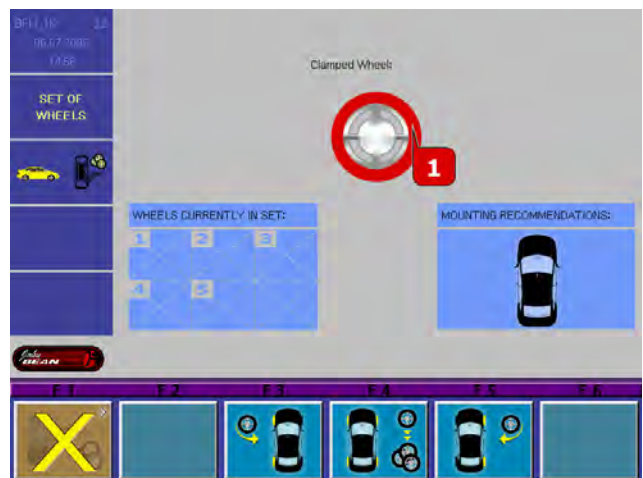

Figure 40

Press F1 to cancel the complete procedure and **DELETE** all data that have already been entered to the set of wheels so far. See Figure 41.



Figure 41

Press the F3 button for wheels that can only be mounted to the **LEFT** side of the car are added to the set. See Figure 42.



Figure 42

Press the F4 button for wheels that can be mounted to **BOTH** sides of the car are added to the set. See Figure 43.



Figure 43

Press the F5 button for wheels that can only be mounted to the **RIGHT** side of the car are added to the set. See Figure 44.



Figure 44

Now the 2nd wheel can be clamped and the measuring run started. Depending on the measurements the **BALANCING** screen or the **OPTIMA ENTRY** screen will come up. After the wheel has been matched and / or the imbalance has been corrected the wheel is unclamped from the balancer and the **SET OF WHEELS 2** screen will come up as shown in Figure 45 with a **GREEN** tag.



Figure 45

Wheel number 2 can now be entered to the set by pushing either F3, F4 or F5, depending which kind of wheel is used.

When the 4th wheel has been measured the **SET OF WHEELS 4** screen will come up. As soon as the 4th wheel has been entered to the set the **BFH 1000** wheel balancer automatically shows which wheel shall be mounted on which position of the car. See Figure 46.



Figure 46

The recommended placement positions are clearly indicated on the screen showing each wheel with a different color.

The proposal for the position of the wheels on the car is given to reduce the pull as much as possible. Should the operator want to position the wheels in a way that the lowest vibration is achieved on the steering wheel he presses the F6 button. See Figures 47 and 48.

By doing this the 2 wheels with the lowest run out are selected to be put to the front axle.

Press button F6 to change to a different pictorial that allows to switch back to selecting for the lowest pull.

F2 allows to start a new set. Pressing the F2 button results in cancellation of all data for wheels that have been stored to a set. See Figure 49.

Pressing F1 will cancel the complete procedure, DELETE all data that have already been entered to the set of wheels so far and EXITS OptiLine. See Figure 50.

When the "OptiLine" feature is disabled, to be enabled again return to the "Optima" screen and Select the "OptiLine" Feature as explained earlier.

NOTE: Please note that the location of the drivers seat can be set by a service code, please contact your service representative for more details. North American Default is Left Side.



Figure 47

lowest run out



Figure 48

lowest pull



Figure 49 - "F2"

Cancel



Figure 50

Exit OptiLine

## 9.1 OptiLine Customer Calibration

The T shaped calibration tool supplied with the OptiLine kit is required for checking and correcting any parallelism disparity between the rear scanner plane and the axis of the machine wheel shaft to guarantee precision measurement of the tread conicity indices. The procedure uses this special Calibration Tool supplied in the kit, on whose front surface the rear laser's beam must run.

The calibration should be carried out regularly. It is recommended to perform a calibration on a monthly basis.

To perform the PULL calibration, proceed as follows:

Open the OPTIMA ENTRY screen page as shown below in Figure 51.

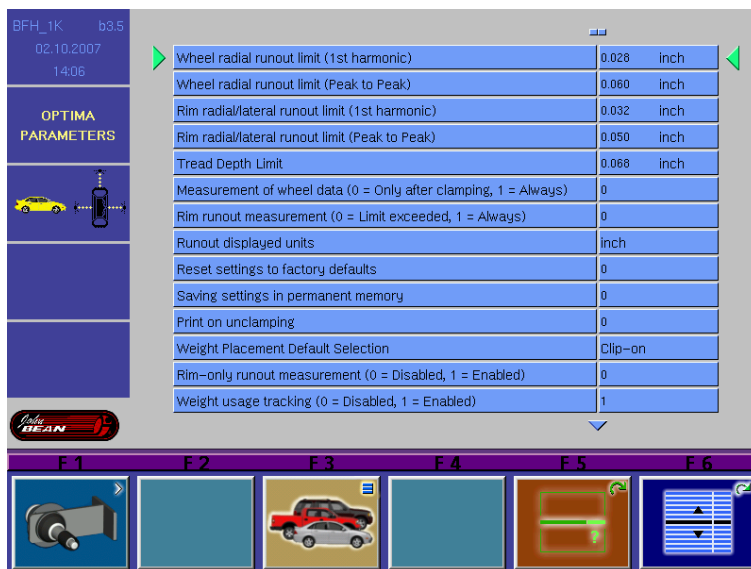

Figure 51

Select key F3 to open the OPTIMA PARAMETERS screen page and select key F1, Fig 52.



Figure 52

Install the Calibration Tool so that the blind hole used as a reference faces the outside of the machine.



Turn the front surface of the Tool towards the back of the balancer, angle the plate towards the scanner, approximately 5 degrees downward, then lock it in position using the pedal brake.

Lower the wheel guard.

Press F6 to start calibration (foot pedal can be released).

The rear scanner will traverse to the right starting the calibration. If the difference between the PULL index calculated by the user calibration and the value set by the factory calibration is less than 0.5, the operation ends with a positive result and the text OK appears.

If the value is excessive, an error E400 (Pull index user calibration failure) is displayed and a service technician should be notified. The balancer will however continue to function correctly for normal balancing procedures.

To exit press ESC.

The procedure is also described on the balancer display when the HELP key is pressed.

***CAUTION: Do not stand in a position that would allow the calibration tool to come into contact with the users leg when released. Remain to the side and away when releasing the tool from the locked position.***



## 10.0 WEIGHT MANAGEMENT



**INTRODUCTION** - The BFH Series Weight Management Software features consist a unique program designed to maximize the tire shops profits while maintaining efficiency. **Weight Wizard™** works to reduce weight costs, and minimize excessive weight inventory. Weight inventory can be tailored by location requirements to avoid waste.

### Weight Wizard™

**Weight Wizard™** is a Patented method using a precision laser to determine the required clip weight type for the rim profile being serviced. The laser can also determine use of stick on weights and precisely place them for maximum performance. As wheel weights are changing from lead to steel due to environmental and health concerns and the cost of wheel weights increasing with the change. Customers can now purchase wheel weights in quantity with regard to weight type and weight amount. This will allow shops to avoid accumulating large quantities of unused wheel weights which are expensive to purchase and difficult to store.

### Viewing the Weight Wizard™ Data File:

From the Main Menu – select the F1 “Function Key”, from the Function Menu screen select the F4 Key to display the Weight Management screen. See Figure 53.

#### 10.1 Weight Wizard™ Features:

- ⊗ Weight Wizard™ indicates both what type of weight and weight sizes that are actually being used.
- ⊗ Knowing the most popular usage, the buyer can tailor the weight purchasing requirements by location and avoid excessive expense and waste.



Figure 53

- ⊗ The time and date of the tracking file is displayed across the top of the screen.
- ⊗ Weight amounts in quarter ounce increments are listed from one quarter ounce through four ounces on the left hand side.
- ⊗ Both an “Acumulated” and “Since this Date” counts are available by toggling “F3”. The “Since” values are reset by selecting “F2”. The Accumulted values must be reset by formatting via the Function Menu.
- ⊗ If tape on weight is used, the amount of tape on weight is also stored.
- ⊗ Weight amount and type is determined automatically by the wheel balancer.
- ⊗ Upon un-clamping of the wheel, the weight type and weight amount is written to this file.



Figure 54

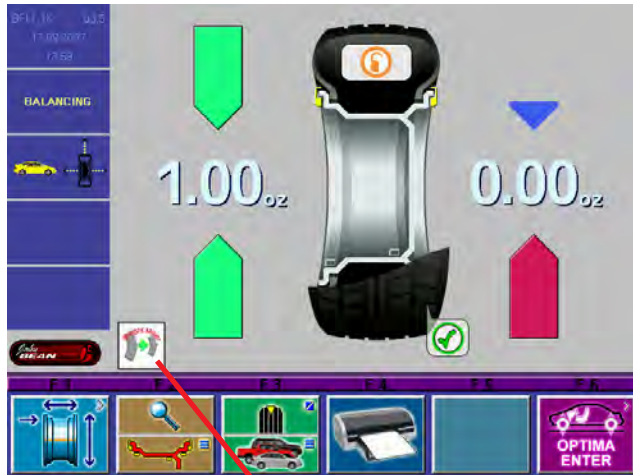

Figure 55

Weight Miser™ is enabled

## 10.2 - Weight Miser™

*Weight Miser™* is a software program that determines if there is the possibility to remove sufficient vibration from a tire and wheel assembly by applying a lower amount of weight than the normal balance function recommends. The amount of residual imbalance left on the tire and wheel assembly is determined by the residual threshold tolerance setting.

Assuming that an amount of residual imbalance accepted nowadays by the automotive industry standards is 5 grams for static imbalance and 10 grams for dynamic imbalance, a new feature *Weight Miser* allows the tire shop to achieve wheel balancing using less – smaller – balancing weights.

It must be very clear that the feature works assuming that some residual imbalance can be left on the wheel. The tire shop will save weight, but wheels will be balanced with a lower degree of accuracy.

The feature – *Weight Miser™* – is disabled by default when the unit is manufactured. The machine will leave the factory in its original high-accuracy balancing configuration.



Figure 56

Enabled

The user has the option to activate the feature from the “*Main Menu*”. See Figure 56. Press the “F3” key to activate *Weight Miser*. The feature is activated when the green icon with the “X” is shown at the “F3” position as shown.



Figure 57



Figure 58



Figure 59

When in the Weight Miser™ mode, software determines if a single weight approach is feasible. If it is possible to reduce both static and dynamic imbalance below the given thresholds using a single weight, then a single weight will be recommended. If not, two-weight balancing will be recommended, but the weight amounts can be lower.

There are five entries in the “**Function Menu**” for Weight Miser™ setup. See Figure 58.

1. Weight Miser™ feature enable – ON/OFF (Function default is OFF)
2. Weight Miser™ static threshold
3. Weight Miser™ dynamic threshold
4. Clip weight to money conversion
5. Stick weight to money conversion

The two thresholds for Weight Miser™ are adjustable. There is a recommended pre-set limiter.

The Weight Miser™ thresholds can be set in the set up function screen as described. Furthermore, a quick way to change thresholds is the vehicle type selection.

For the vehicle category – SUV and Truck, there is a multiplier that increases the threshold from the preset **CAR** values due to the fact that these vehicle types can tolerate a higher residual imbalance. See Figure 59.

<u>Vehicle type</u>	<u>Threshold</u>
Passenger Car	1x
Motorcycle	1x
SUV	1.5x
Light Truck	2x

The weight to money conversions are adjustable to display the approximate amount of money savings relative to the weight savings. The user can change the value of conversion depending upon his weight purchase costs

To observe the Weight Miser™ screen as shown in Figure 57, press the F5 button when in the Weight Wizard™ screen.

## 11.0 USER CALIBRATION

The BFH 1000 Balancer features a user calibration program which requires only a few minutes to complete. Perform this procedure when the balancer has been moved, disturbed, or whenever accuracy is questioned. Occasional field calibration will ensure years of reliable service.

Follow these 3 simple steps for shaft calibration:

1. Press and release the **“Function”** key (F1) from the **“Welcome or Main Screen”**.
2. Press and release the **“Calibration”** key (F1). Fig 60.



Figure 60

3. Place 2 cones followed by the clamping nut (no retainer) onto the shaft. Lift the pedal to clamp. See Figure 61.

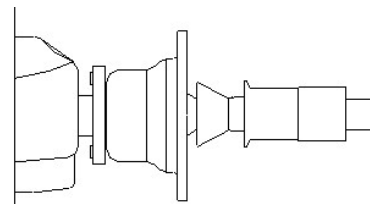

Figure 61 - 2 cones & clamping nut only

4. Lower the wheel guard and press the **“SPIN”** key. The balancer should spin and come to a complete stop. See Figure 62.



Figure 62

4. After the balancer comes to a stop raise the wheel guard and screw the calibration slug into left side of the flange plate. Lower the wheel guard and press the **“SPIN”** key. The balancer should spin and come to a complete stop. Once the shaft stops the display should display **“OK”** and the speaker sounds the Snap-on **“TüDüLü”**. See Figure 63.

### SHAFT CALIBRATION IS COMPLETE



Figure 63

---

## 12.0 EXPLANATION OF PROGRAM CODES

In the event of damage or malfunction, a code may be displayed indicating the area or location of the detected error. These codes are important to the service agent when he services the unit. Note any codes or error messages before calling for service or assistance.

- 1. Communication between micro-controller and embedded PC (Blue screen)**  
Service Codes: No service code available Communication between micro-controller and embedded PC is not OK (check connecting cable). This can also indicate a bad connection to the keyboard.
- 2. Check availability of keyboard (E 300)**  
Service Codes : No service code available The microcontroller was not able to detect a keyboard. Check cabling between microcontroller and keyboard.
- 5. Check keyboard (E 89)**  
One of the keys F1 to F6, HELP, ESC, START supplies a "Stuck key" code. The machine will proceed with the next step only if the trouble is remedied.
- 6. Check pedal switches (E 89)**  
Press STOP or ESC key to check the pedal switch once to delete the error code reading. If the trouble cannot be remedied, the pedal is made inoperative.
- 7. Check BFH Calibration (E 360)**  
The optima hardware requires wheel profiler position calibration.  
When the camera controller board is replaced on the machine, the SW detected that calibration data is missing. A Service Calibration procedure is required to calibrate the actual position of the laser scanners with respect to the balancer reference plane. Contact a Service Representative.
- 8. Check BFH Hardware (E 361)**  
Wheel profiler is not present or responding during the self test. The balancer controller board was not able to communicate with the camera controller board during startup test.  
Possible causes:
  - The camera controller board is missing or dead.
  - The cable connecting the balancer controller board and the camera controller board is unplugged, damaged or missing.
- 9. Check BFH Hardware (E 362)**  
Service Codes : All codes available for this model  
Main camera board self test failed.  
Balancing is not possible since wheel data cannot be scanned.  
Problem during power up. Switch power off and on again. Possible camera board failure.
- 10. Check BFH Inner Scanner (E 363)**  
Service Codes : All codes available for this model  
Left side scanner self test failed or CCD not calibrated or zero mark not detected.  
Balancing is not possible since wheel data cannot be scanned.
- 11. Check BFH Outer Scanner (E 364)**  
Service Codes : All codes available for this model  
Right side scanner self test failed or CCD not calibrated or zero mark not detected.  
Balancing is not possible since wheel data cannot be scanned.
- 12. Check BFH Rear Scanner (E 365)**  
Service Codes : All codes available for this model  
Rear scanner self test failed or CCD not calibrated or zero mark not detected.  
Wheel data can be scanned, balancing is possible. Runout measurement of the wheel is not possible.



**A. Hardware test -common errors**

**C10F02** -Test returned with an error. No valid test results available

**C10F07**-Test function reported an unkown error

**C10F18**-Test timed out. No valid test results available

**B. Hardware test -Power supply voltage**

**C10800**

**C10801**

**C10804**

If the line voltage is below or above a limit the error code is displayed.

**C. Hardware test -5V line**

**C10810**

**C10811**

If the 5V voltage is below or above a limit the error code is displayed.

**D. Hardware test -Current of optoelectronic LED**

**C10705**

**C10706**

**C10707**

**C10708**

If the current / voltage is below or above a limit the error code is displayed.

**E. Hardware test -Transducer signals**

**C10410**

**C10420**

**C10430**

Checks transimpedance and signal amplifiers and transducer values. If no signals from the transducers are detected the error code is displayed.

**F. Hardware test -Auto stop system**

**C10380**

**C10381**

**C10382**

**C10383**

Checks voltage on capacitor of the auto stop system.

If the voltage is below or above a limit or the recharging time is above a limit the error code is displayed.

**14. Hardware test disturbed H 82**

**15. Power clamp service interval expired E93**

---

## 13.0 MAINTENANCE

**BEFORE ANY MAINTENANCE OR REPAIRS ARE ATTEMPTED THE MACHINE MUST BE DISCONNECTED FROM THE ELECTRIC SUPPLY.**

This balancer does not require any special maintenance, but the following precautions are required:

- A. Periodically clean all plastic parts with a glass cleaner. Wipe with a dry cloth.
- B. Clean all adapters regularly with a nonflammable liquid detergent all. Lubricate with a thin layer of oil.
- C. Periodically perform a routine shaft calibration as outlined on page 33 of this manual.

## 14.0 TROUBLE SHOOTING

<b><u>TROUBLE</u></b>	<b><u>CAUSE</u></b>	<b><u>REMEDY</u></b>
When turning the machine on, the displays do not light	No electric power Defect in the electric/electronic system	Check the input voltage Call the Local Service Rep for assistance
The machine gives random readouts.	Machine unstable on the floor Water in the tire Loose adaptor Defective electronic board	Check that machine is stable Remove water from tire. Tighten the adaptor firmly Call the Local Service Rep for assistance
The machine does not stop after balancing cycle	Defective electronic component	Stop using the machine immediately and call the Local Service Rep for assistance
The balancer is slow to display when powering machine up.	This machine performs a self-test routine on start-up. There will be a delay of several seconds before the display is activated.	This is a normal characteristic of the machine
If the balancer ceases to properly measure parameter values	Malfunction of one of the scanners, A failure of the AWP system, or harness connection failure.	Call the Local Service Rep for assistance





## ***NOTES***

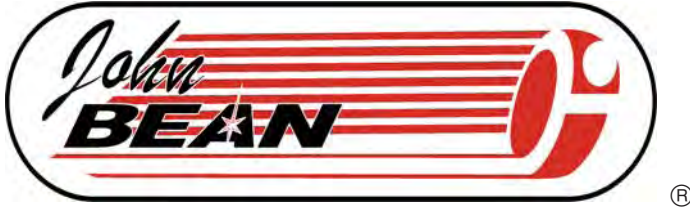

#### **USA**

Equipment Services  
309 Exchange Avenue  
Conway, Arkansas 72032  
Tel.: (800) 225-5786

#### **UNITED KINGDOM**

UK Equipment Ltd  
48 Sutton Park Avenue,  
Reading RG6 1AZ  
Tel: +44(0) 118 929 6811  
Fax: + 44 (0) 118 966 4369

#### **LATIN AMERICA**

International Equipment Group  
309 Exchange Avenue  
Conway, Arkansas 72032  
Tel.: (501) 450-1526  
Fax: (501) 450-2086

#### **ITALY**

Snap-on Equipment s.r.l.  
via Prov. Carpi, 33  
42015 Correggio (RE)  
Tel: 39 0522 733600  
Fax: 39 0522 733610

#### **CANADA**

John Bean  
6500 Millcreek Drive  
Mississauga, Ontario  
Canada L5N 2W6  
Tel: (905) 814-0114  
Fax: (905) 814-0110

#### **FRANCE**

Snap-On Equipment France  
Za du Vert Galant  
15, rue de la Guivernone BP 7175  
95310 Saint-Ouen-L'Aumône  
Tel: +33 (0) 1-3448-5894  
Fax: +33 (0) 1-3448-5870

#### **GERMANY**

Snap-on Equipment GmbH  
Werner-von-Siemens-Str. 2  
64319 Pfungstadt  
Tel: +49 (0) 6157 12 600  
Fax: +49 (0) 6157 12 601

**Notice:** The information contained in this document is subject to change without notice. **Equipment Services** makes no warranty with regard to this material. **Equipment Services** shall not be liable for errors contained herein or for incidental consequential damages in connection with furnishings, performance, or use of this material.

This document contains proprietary information which is protected by copyright and patents. All rights are reserved. No part of this document may be photocopied, reproduced, or translated without prior written consent of **Equipment Services**.



is a registered trademark of Snap-on Incorporated