

BFH800™

Operations
Manual



JohnBean™

**Contents •
Safety rules and function**

Updating Guide:	
Release A - _____	Mar. - 2011
Documentation issue.	PCN : 10G0184

Contents	Page
Updating guide	4
1. Safety rules and function	5
2. Installation of the machine	15
3. Introduction - Accessories	21
4. Controls and displays	27
5. Switching on the machine	53
6. Clamping the wheel	61
7. Operations – MANUAL – Settings	73
7.8 Operations – AUTOMATIC “PROFILING”	97
8. Balancing the wheel	109
8.4 Behind-the-spokes placement	121
9. Optimization/Weight minimisation	127
10. Operating Mode - Settings	145
11. Error codes	159
12. Calibration by the operator	171
13. Maintenance	173
14. Technical data	175
Product requirements	178

1. Safety rules and function

Fig.1-0 Many Safety Precautions relevant to the unit are described in the Safety Booklet.

1.1 Special hints for the reader

A few special features were used in this manual to facilitate reading and understanding of pictures and written instructions:

- signals the operator where to act.

Safety rules are highlighted in grey.

Note:

provides a suggestion or an explanation.

1.2 Scope of application

The wheel balancers are designed for static and/or dynamic balancing of car, Suv and light-truck wheels weighing up to 70 kg and having an overall diameter of 950 mm.

In addition to conventional balancing operations, irregular running conditions of the wheel caused by geometric deformations of the rims and/or tires, hence un-smooth ride, can be identified, improved or, if possible, even eliminated. By exact adjustment of the two wheel components relative to each other optimum wheel running conditions or at least balance weight minimization can be achieved.

The manufacturer shall not be considered liable for possible damage caused by improper, wrong or unreasonable use.

Contents • Safety rules and function

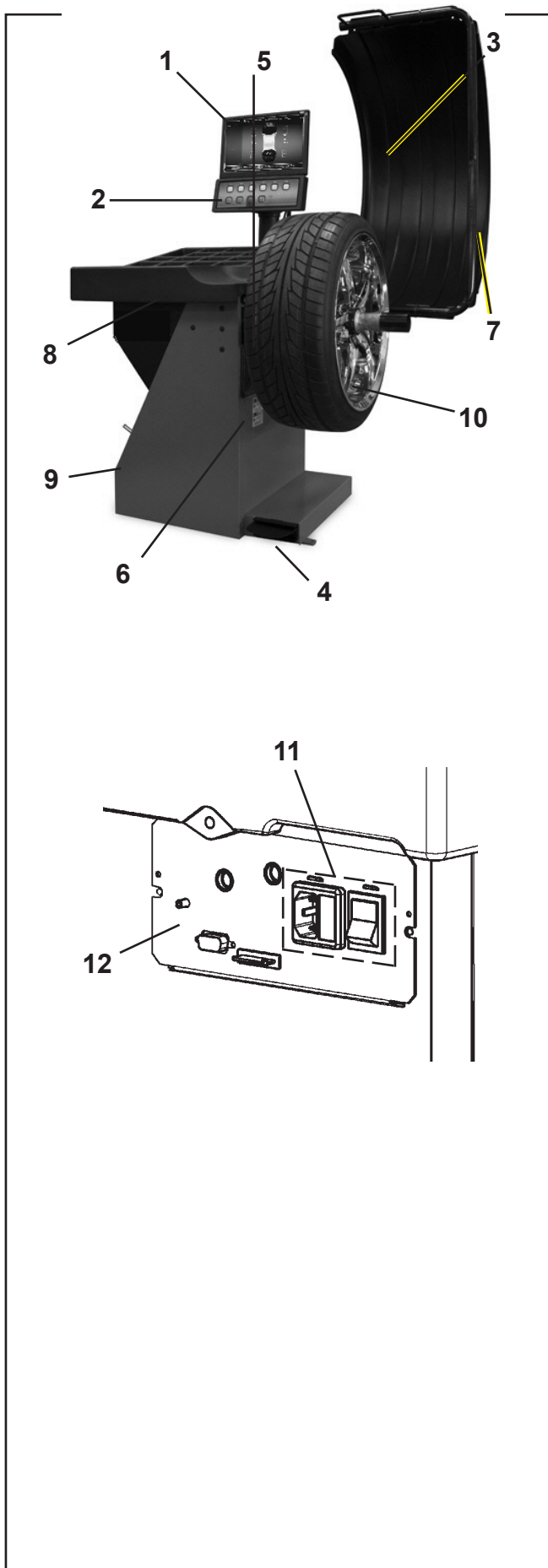

Fig.1-1 Front view of

- 1 Monitor
- 2 Key pad
- 3 Wheel guard
- 4 Pedal of main shaft lock
- 5 Measurer arm for rim distance
- 6 Laser Scanner
- 7 Sonar Sensor
- 8 Weights Compartments
- 9 Storage areas for cones
- 10 *Power Clamp Shaft*

Fig.1-2 Rear view of

- 11 Power outlet-Fuse holder-Main Switch
- 12 Embedded PC

1.3 General safety rules

Only properly trained and authorized personnel shall be allowed to operate the wheel balancer.

The machine must not be used except for the scope of application and in the way specified in this manual.

Unauthorized changes and modifications to the machine relieve from any liability for damages and injuries that might result therefrom.

On no account should safety features be removed or made inoperative.

In general any work on the electrical system such as fitting of a plug or changing of connections, if necessary, must be carried out by a qualified electrician in line with relevant national standards and the regulations of the local power station.

Remove jumper X46 prior to insulation resistance tests (500 V DC) and high voltage tests (1000 V AC) in line with EN 60204-1 (see electrical diagram).

It should be noted that working with technical equipment may always involve an unforeseeable acceptable risk.

Therefore the operator should eliminate such dangers in advance by proper and wise behavior.

The following special points should be observed:

Use technical equipment for its specified scope of application only.

Always use suitable and proper equipment and tools.

Follow the instructions, notes and technical data of the machine manufacturer or manufacturer of the wheels to be balanced.

Wear suitable protective clothing and accessories (e.g. goggles, safety shoes, helmet).

avoid eye contact with the laser scanner;

Lowering the wheel guard, simultaneously detecting the rim width with the ultrasound sensor, requires maximum operator attention.

For further safety rules to be observed, please refer to the Supplement „SAFETY MEASURES“ and the individual chapters.

Safety rules and function

1.4 Description of function

Screen and menu keys

The color screen displays the data set, the operating modes, the measured data and symbols and text to help the operator.

The drop down menus, with the lists of all the functions, are on the bottom. The keypad contains the six Menu control keys and the ESC, HELP, START and STOP keys. A touch control vertical cursor and an OK key, on the right, are used to scroll and activate the highlighted options

Detection and Input of rim data

Using the laser scanner with integrated CCD and the external sonar sensor, the machine acquires all of the parameters needed to calculate unbalances.

If data entry via the key pad is preferred, the relative function key is pressed to choose the desired inputs and enter them into the electronic unit.

Input range is identical with the working range of the machine (see § 15. Technical data).

Balancing mode

Readings in different balancing modes (weight position on the rim) can be given on the display, depending on the type of wheel to be balanced (car, light-truck, PAX, steel or alloy rim).

Measuring run and measured values

All measurements are taken and stored in one run during the automatic program. On completion of measurement the machine stops automatically and the wheel is slowed down to standstill.

Amounts and locations of unbalance are read out separately for each correction plane.

Store wheel profiles

Wheel profiles permit the storage of values for wheels that for example are balanced frequently in order to save having to enter the wheel data etc. each time. It is possible to store up to 9 wheel profiles.

Error codes

Errors in operation or failures in the electronic or mechanical system are signalled via respective error codes (see § 11. Error codes).

Safety rules and function

Readjustment by the operator

If several measuring runs are necessary to balance a wheel because balance weight size and position have to be adjusted repeatedly, this is often due to insufficient measurement accuracy.

In such case the operator has the possibility of readjusting the machine (see § 13. Readjustment by the operator).

Wheel guard

A wheel guard with electric interlock is utilized and is part of the standard equipment. The measuring run may only be started with closed guard.

The electronic unit can be programed by simply changing the relevant mode of operation so that measurement is started by closing the wheel guard (see § 10. Changing modes of operation).

Main shaft lock

The machine has a pedal-operated main shaft lock which is used to retain the wheel in the correction position so that the balance weights can be fitted. This lock is designed only to facilitate orientation of the wheel and must not be used for braking the main shaft.

The pedal also controls the *POWER CLAMP*, for clamping the wheel on the balancer.

Safety rules and function

1.4.1 Description of function

In Automatic Mode, when the wheel guard is lowered the wheel dimension acquisition starts, and it is completed during the measuring run.

When the closure is complete the run starts, then the wheel stops and the weights to apply are displayed on the screen, along with the coordinates for their positioning.

The balancer can operate in two distinct modes:

- a) MANUAL
- b) PROFILING

MANUAL

The machine provides basic functions of determining the position and value of the weights to apply to the rim. Wheel dimensions are manually entered prior to the balance run. The MANUAL mode is activated through the functions menu.

PROFILING

This mode is identifiable on the monitor with the symbol displayed in fig. 1.4-1. The control software automatically acquires the wheel dimensions during the measuring run. During the normal measurement cycle the scanner automatically samples the internal shape and dimensions of the rim.

The machine can then optically suggest the exact application point of the weight on the rim by means of a laser beam, with the so-called laser pointer device (activated on request).

1.4.2 Switching operating modes

(fig. 1.4-2)

The balancer can be set so that it presents the desired mode of operation at power-on.

- Set the desired value in the functions menu:
 - MANUAL;
 - PROFILING;

Note:

Refer to Chapter 10 for the complete Operating Modes Setting procedure.

Installation of the machine

2. Installation of the machine.

When choosing the site, Health and Safety at Work regulations and the regulations on working environment should be taken into account.

The wheel balancer can be installed on any kind of floor that is level and even (horizontal; tolerance +/- 1°-when level; tolerance up to 2 mm). The weight and overall size of the machine are given in Chapter 15. Technical Data. Before installing the machine on a raised floor, check its carrying capacity.

The machine can operate even if it is not fixed to the floor as long as it rests correctly on the floor at the three points indicated (**a, b, c, Fig. 2-1**).

If metal spacers are used to achieve the necessary floor conditions for installation, the machine must be secured to guarantee long term stability. To secure the machine: mark the position of the machine drill holes on the floor, then move the machine, drill the holes in the floor and insert the screw anchors. Then position the machine back over the holes and insert the bolts. Use metal screw anchors with diameter 10 bolts. The packaging on the pallet (**Fig. 2-2**) guarantees machine condition at delivery.

2.1 Unpacking the machine

The machine should be unpacked by two persons.

Note

When unpacking the machine make sure that the pedal fitted on the machine base and the whole pedal assembly is not damaged.

- Cut the strips of the packing (**Fig. 2-2, item 1**), lift off the packing and set aside the small parts packed in the separate small box (**Fig. 2-2, item 2**).
- Unscrew the three hexagon screws (width across flats 13 respectively) which hold the machine on the pallet (**Fig. 2-3**).
- Gently lift the machine by weight box and wheel guard carrier (**Fig. 2-3**).
- Then lower one side of the machine on the floor (**Fig. 2-4**).
- Remove the pallet from underneath the machine and gently lower the entire machine onto the floor (**Fig. 2-5**).

2.2 Moving the machine

If the machine is transported on site, gently tilt it, taking it by weight box and wheel guard arbor, and push it gently on suitable lifting or mobile industrial handling equipment (e. g. forklift truck, platform truck).

Note

When moving the machine **do not pick it up by the Wheel Holder Shaft**.

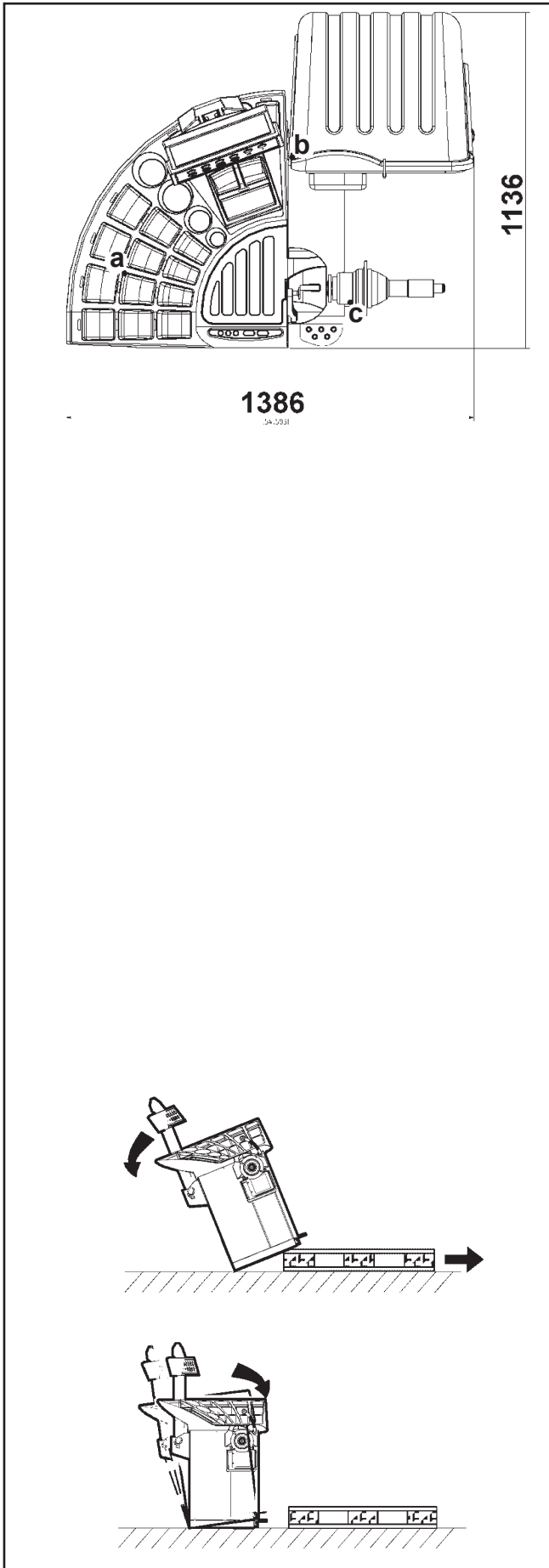

Installation of the machine

Fitting and connecting the monitor

Fig. 2-6 Fitting the monitor

1) The VESA support has three different fixing points, which thanks to the two possible fitting positions (**1a-1b**) provide 5 different possible fixing heights. The 4 screws needed (M4x10) to fix the VESA support to the monitor are part of the kit supplied.

2) When fitting the monitor assembly you must choose the appropriate fixing point.

The monitor assembly must be positioned in such a way as to leave a minimum gap vertically between the monitor and the keyboard support, allowing its angle to be adjusted.

Fig. 2-7 Connection of monitor and PC

CAUTION
BEFORE CONNECTING THE ELECTRONIC CABLES TURN OFF THE MAINS SWITCH.

- Insert the monitor connector into the right-hand socket (**item 1**) of the embedded PC unit.
- Insert the monitor main connector into the socket (**item 2**).
- Insert one end of the connecting lead from the embedded PC to the electronic control of the wheel balancer into the left-hand socket of the embedded PC (**item 3**), and insert the other end into the socket close to the main switch.

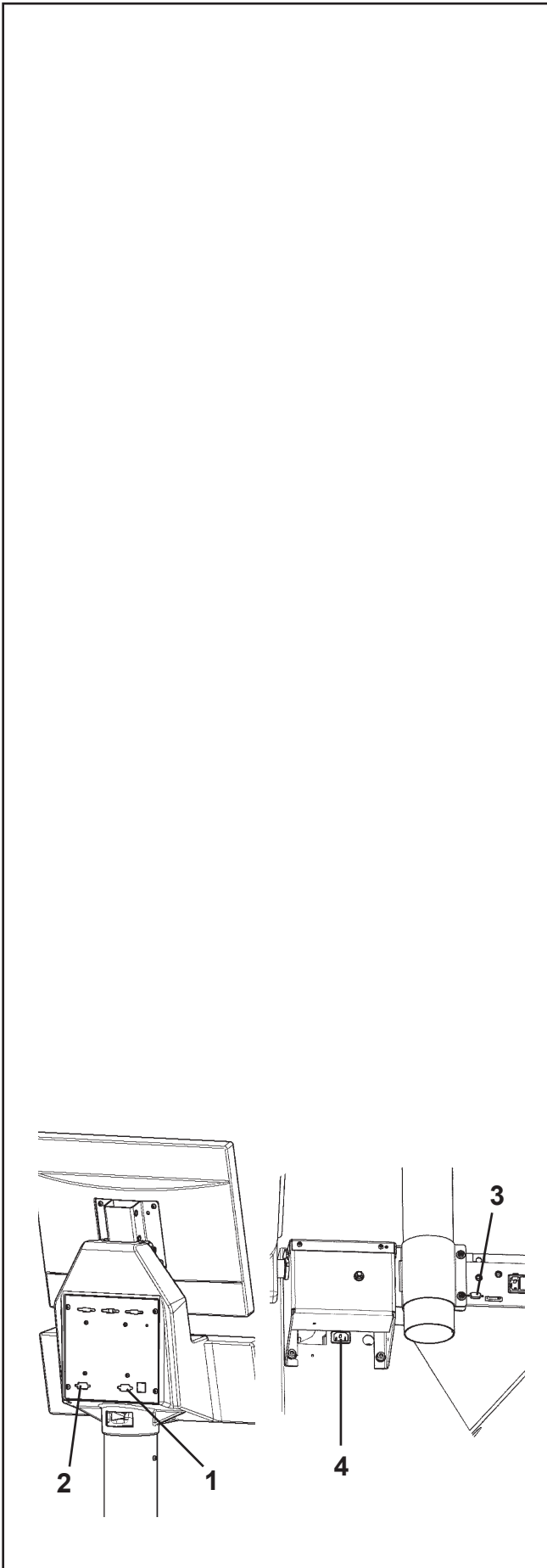

Electrical connection

2.3 Mounting the wheel guard

The wheel guard influences the following modes of operation:

- The measuring run is started by closing the wheel guard (code C 13).
- The wheel is braked on lifting the wheel guard during a measuring run (code C 5).

Fig. 2-8

- Slide the wheel guard (1) on the arbor (2) and raise it until the fastening holes of wheel guard and wheel guard arbor coincide.
- Insert the M10 setscrew (3) with washer (4) from below, and tighten the hexagon nut (5) and washer.

Fig. 2-9

- Connect the plug of the cable (6) with the connector of the machine (7) which is projecting out of the opening in the machine cabinet.
- Place the plugs loosely inside the machine through the hole in the machine cabinet.

CAUTION:

Since the cable is moved during opening and closing the wheel guard, it must be passed in the band (8, Fig. 2-9) under the wheel guard.

2.4 Electrical connection

Any work on the electrical system such as fitting of a plug or changing of connections, if necessary, must be carried out by a qualified electrician in line with relevant local standards and regulations.

Electrical standard equipment and drive motor of the wheel balancer are provided for operation on AC 50/60 Hz, 200 – 240 V.

The connecting cable of the machine is provided with a protective plug IEEE standard.

The electrical diagram is illustrated in "Spare Parts" document.

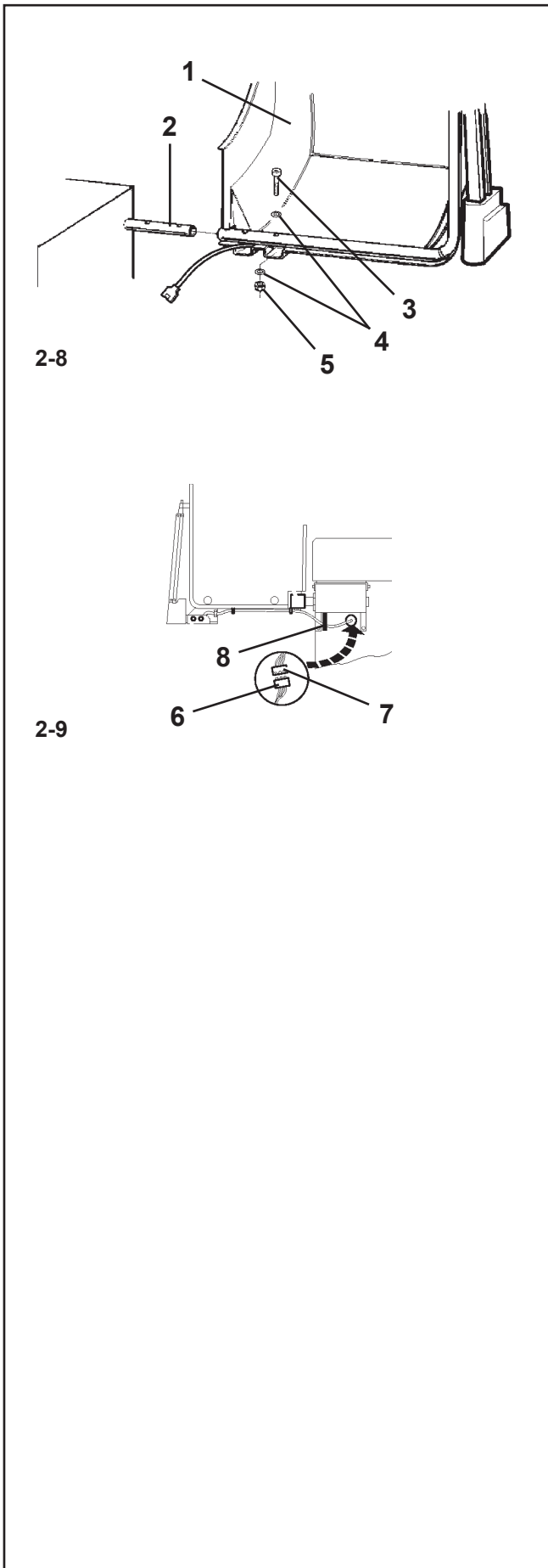

Introduction

3. Introduction

This wheel balancer uses the most advanced technology and electronic instrumentation. Through an integrated personal computer two separate laser and ultrasonic sensors detect the wheel dimensions and guarantee the most simple and easy operating procedure.

The time and effort required for its use are minimized, but without compromising precision and reliability.

The low rotation speed of the wheel ensures that this balancer is very safe.

Always work in a clean area and with clean wheels, no dirt stuck in the tire or on the rim.

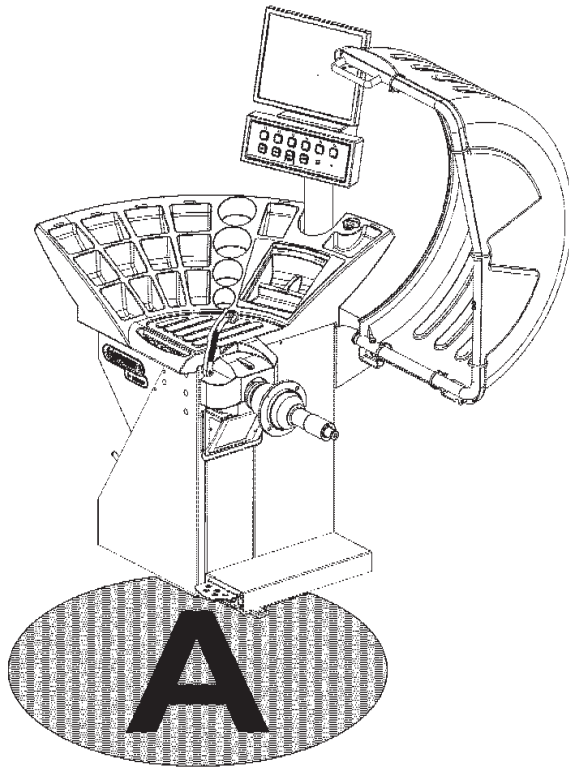

WARNING:

THIS MACHINE HAS A SINGLE OPERATING STATION (A). THE OPERATOR IS RESPONSIBLE FOR RESTRICTING ACCESS TO THE WORK AREA AND FOR ANY CONSEQUENCE ARISING FROM USING THE EQUIPMENT

Note:

THE USE OF THIS DEVICE IS ALLOWED ONLY TO PERSONNEL DULY TRAINED BY AN AUTHORIZED DEALER AND IN POSITION (A).

OPERATOR MUST BE NEAR THE MACHINE IN GOOD WORKING POSITION; CONTROL SIDE (A).

Manuals for the unit

Information related to the unit is in:

- Operator's Manual (Chapters 1 – 8).
The operator must be familiar with it.
- Service Manual (standard supplement)
Manual for use by service personnel only.

Installation instructions.

The installation instruction are in Chapter 2.

3.1 Accessories

Refer to Figure 3.2.
Standard accessories:

- | | | |
|---|-------------------------|-------------|
| 1 | Weight pliers | EAA0247G22A |
| 2 | User Calibration weight | EAM0005D40A |
| 3 | Kaliper | EAA0247G21A |
| 4 | Cup - Large Pressure | EAC0058D07A |
| 5 | Power Clamp Nut | EAM0005D45A |
| 6 | Plastic Sleeve | EAM0005D54A |
| 7 | Soft Protective Ring | EAC0058D15A |
| 8 | Small Presure Disk | EAC0058D08A |

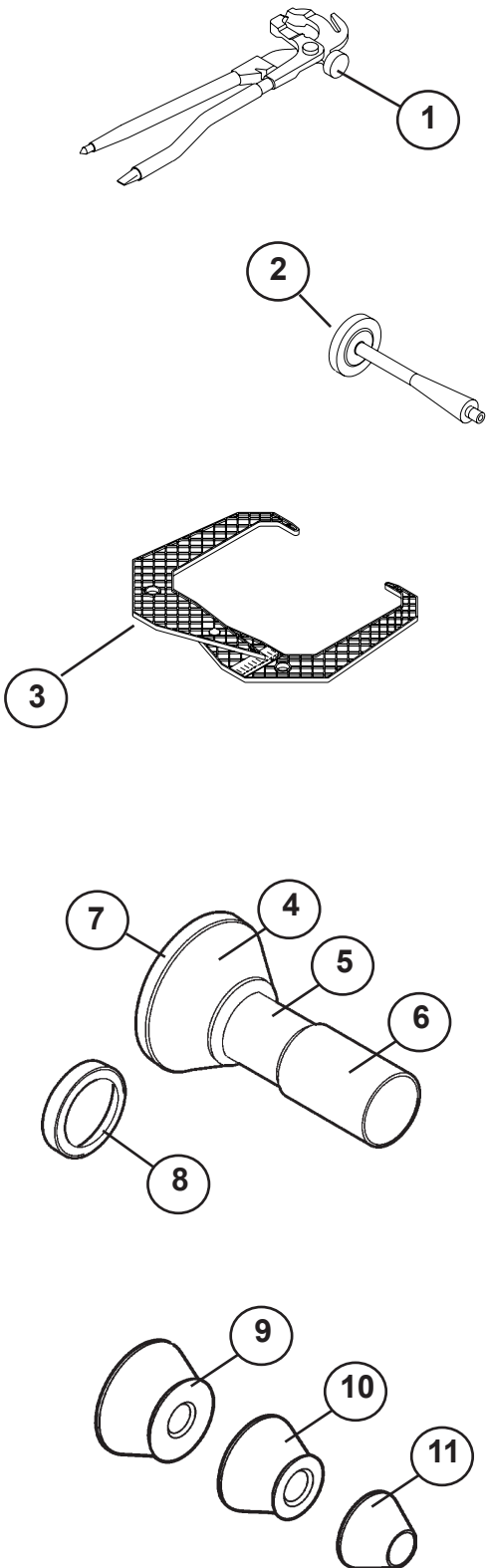

3.2 Optional Accessories

- | | | |
|----|-----------------------------|-------------|
| 9 | Cone, 96-116 mm / 3.8"-4.6" | EAM0005D25A |
| 10 | Cone, 72-99 mm / 2.8"-3.9" | EAM0005D24A |
| 11 | Cone, 42-77 mm / 1.6" - 3" | EAM0005D23A |

3.2 Optional Accessories continued

Refer to Figure 3.3.

1



1 Wheel Lift

EAK0221J27A

2

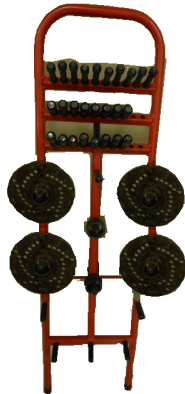

2 Flange Plate Cart

EAS2081J30A

3



3 Flange Plates - Kit of 4

EAK0221J22A

3-3

Refer to the Price List for information about all the available optional accessories.

Controls and displays

4. Controls and displays

4.1 Key pad

Fig. 4-1 Key pad

- 1 Menu keys (associated with a menu field)
- 2 ESC key
- 3 HELP key
- 4 START key
- 5 STOP key (emergency stop)
- 6 Loudspeaker outlet
- 7 Pilot light, Scroll or OK Key active
- 8 Pilot light, power supply ON
- 9 OK key (touch control)
- 10 Cursor, SCROLL (touch control)

Description of keys

1 Menu keys

Figure 4-1a Keys

- The Menu Keys open the list of functions to perform or continue the operating cycle

All function keys are toggle switch type keys so they have triple commands plus two functions:

Command a

Pressing the center

Opens the Menus

Activates the Menu item when selected.

Command b

Pressing the upper part

Opens the Menu and selects the first item on the bottom directly.

With the Menu open, it moves the selection on the upper function on the list.

Command c

Pressing the lower part

With the Menu open, it moves the selection on the lower function on the list.

Depending on how they are used by the program, each key can have other functions too, e.g.:

Hold down function

If the key is used in "keep pressed" mode it will scroll a series of values or data.

Release function

After the key has been used in "hold down" mode, when you let go of it the data selected is inserted automatically

2 ESC key

- Exits any Menu.
- Exits the C codes procedures
- Deletes the help information and error messages.

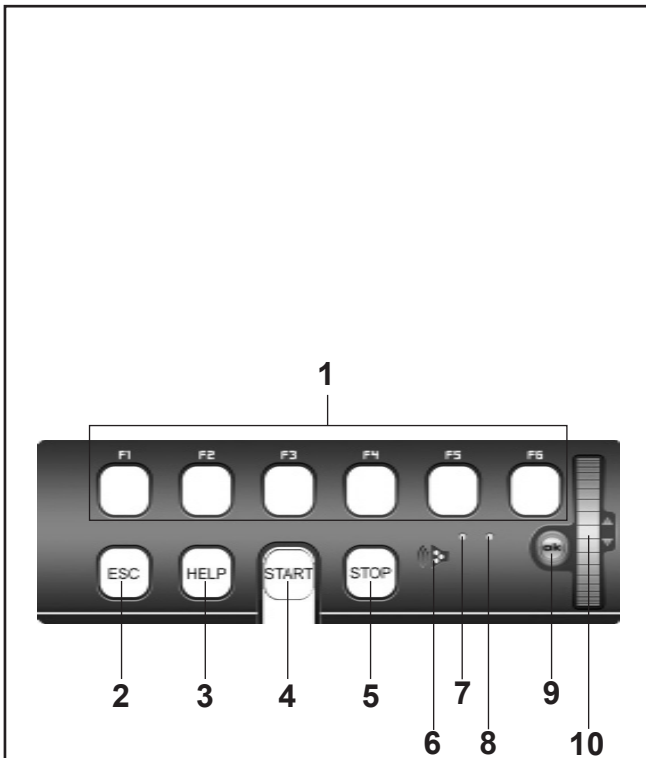

4-1

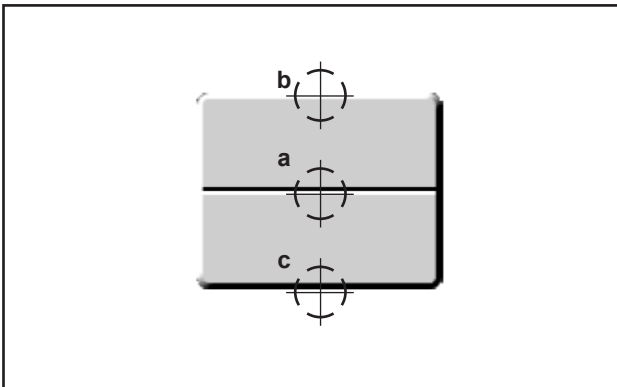

4-1a

Controls and displays

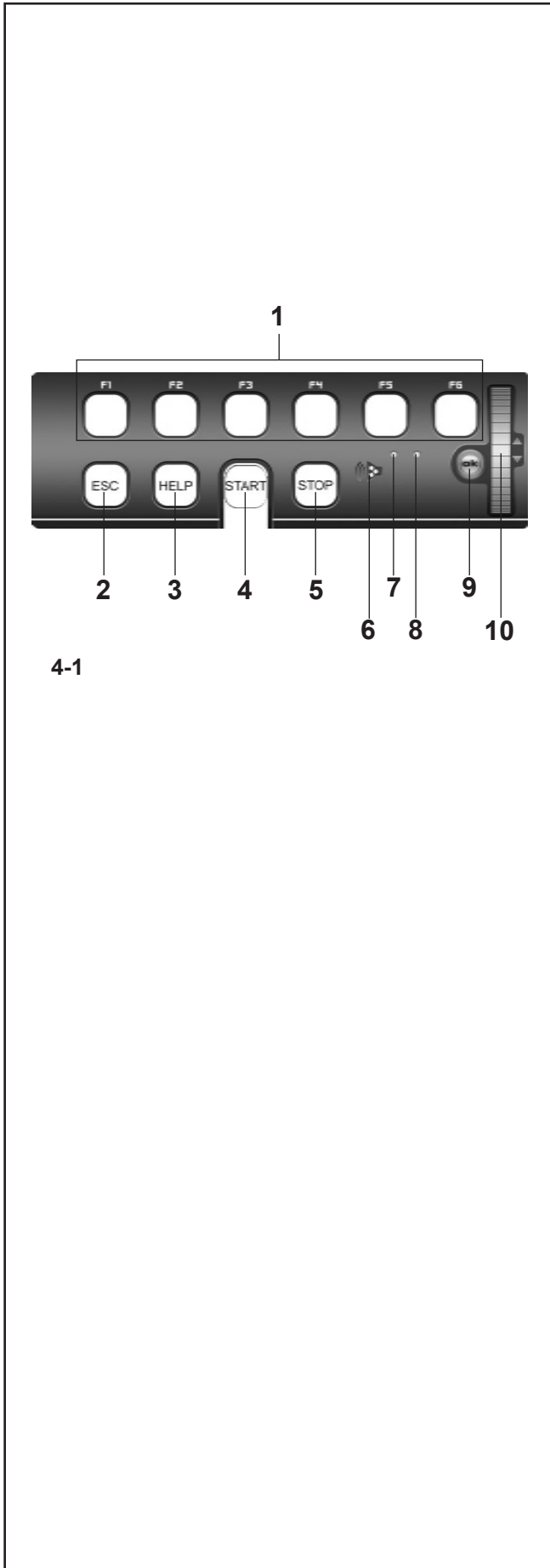

4-1

3 HELP key

- Display useful information to explain a situation and – in case of error codes – provide hints for remedy.

4 START key

- Start the measuring run.

By setting the relative mode of operation accordingly it is possible to start measurement by closing the wheel guard (see §10. Changing modes of operation).

5 STOP key (Emergency Stop)

- Stop a measuring run that has just been initiated and brake the wheel.

Note

The STOP key also has an emergency stop function.

6 Loudspeaker Outlet

- Loudspeaker for acoustic signals.

7 Pilot light, Scroll or OK Key active

- When the touch control scroll selector or the OK key are in use, the pilot light switches on to inform the operator that they are operational.

8 Pilot light, power supply ON

- The LED lights up when the mains switch is turned on and the operating voltage is available.

9 OK key

- Inserts the Menu options selected previously. Touch control key.

10 Touch control cursor, SCROLL

- Scrolls the items in the Menu. Touch control key.

4.2 The screen

Fig. 4-2 Screen with display fields

- 1 Status Bar field
- 2 Display field of screen
- 3 Menu fields of screen

The screen displays the function Menus, the data set, the operator information, all the measured data and the error messages.

Description of display fields

The screen is subdivided into various display fields, each of which is associated with a certain type of information.

Status Bar Field

- 1 Active Function Icons
 - Type of Vehicle
 - Type of Alu
 - Operating Mode
 - Error messages
 - Online Help

2 Display field

- Number of the installed program version
- Machine name
- Date and time
- Rim dimensions
- Balancing modes
- Direction of orientation and correction position (location of unbalance)
- Amount of unbalance
- Selected wheel profile

3 Menu fields

The symbols for each operating menu are displayed in the six menu fields. Under each Menu icon there is a pull-down menu and other Function or Submenu options.

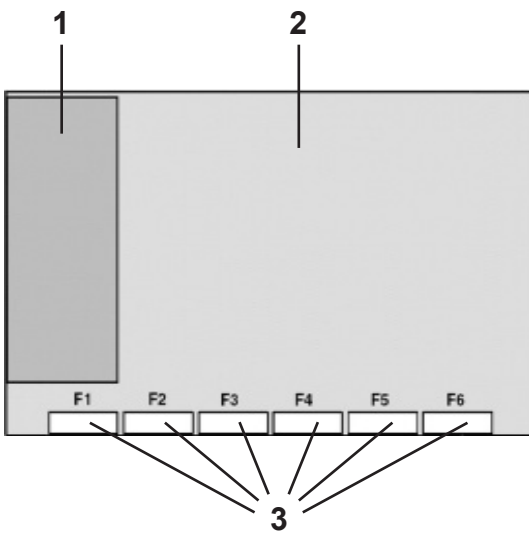

4-2



4-3

Fig. 4-3 Initial screen/Main menu

4.3 Icons – Symbols

Icons are viewed on the screen in all fields: In Information fields, menu fields, and in the display field.



P1



P2

P2 Rim type 1 – standard rim

Balancing modes

P5 Alu 0 - normal - Standard balancing mode

P13 Alu 1

P14 Alu 2, Alu 2P

P15 Alu 3, Alu 3P

P16 Alu 4

P17 Alu 5

P13 Display of unbalance measured and direction indicator (red arrows or arrow heads)

P14 Correction position reached (green arrows)

P15 Correction position for both correction planes reached

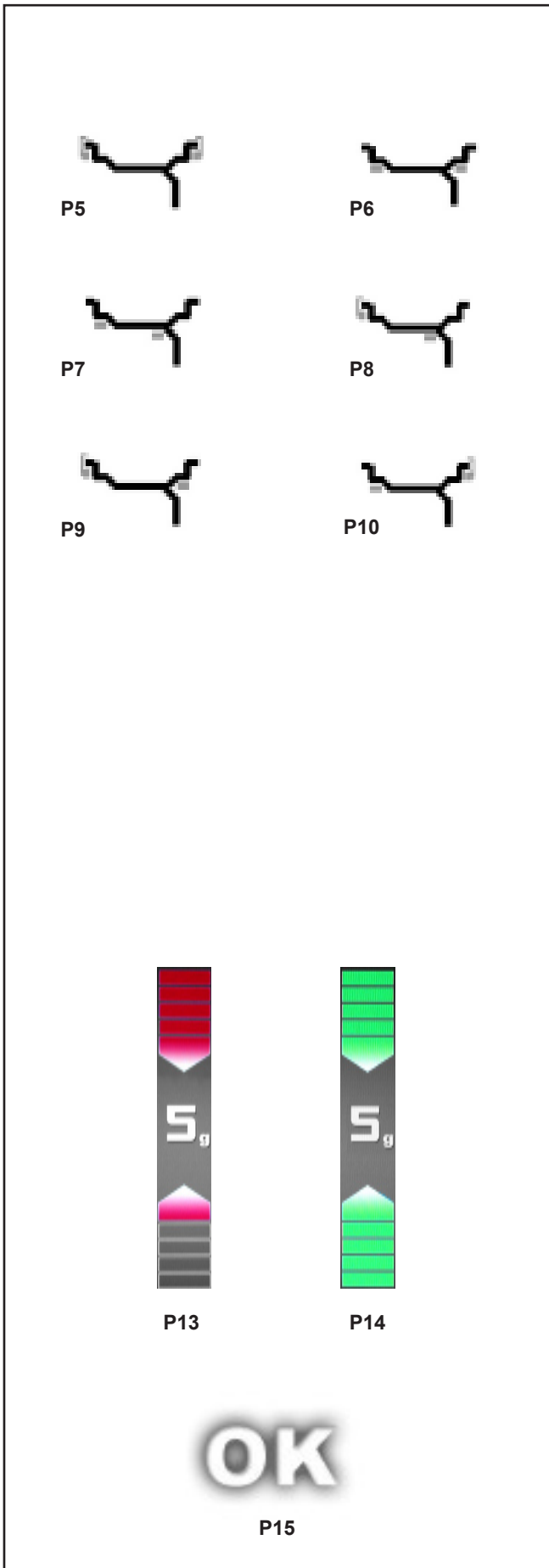

Controls and displays

P16



P16 Compensation run carried out

P17



P17 Lower the wheel guard and press START to start the measuring run.

P18

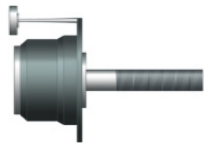

P18 Calibration weight

P19

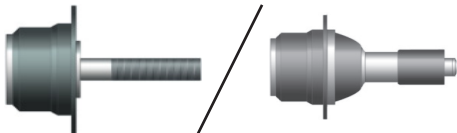

P19 Main shaft / Power Clamp



P20



P21

P20 Provide mark on left tire side

P21 Provide mark on right tire side.

Controls and displays



P24



P25



P26



P27



P28



P29

P24 Fit tire on rim and inflate to the specified inflation pressure.

P25 Turn tire over on rim.

P26 Rotate rim until valve is exactly perpendicular to and above the main shaft.

P27 Rotate wheel until valve is exactly perpendicular to and above the main shaft.

P28 Readjust tire on rim until the mark coincides precisely with the valve.

P29 Readjust tire on rim until the double mark coincides precisely with the valve



P30

P30 Tire changer

4.4 The Menus

The machine function menus are always on the bottom part of the screen. The active menus can be opened by pressing the relative function key inside the various screens.

The active menus are marked by the icon of the menu contents.

The balancer setting and reading functions can be selected with the menu items in the menus.

The Menu Keys operating mode is the same for all the menus and in all the machine screens

For example:
(Figure 4-1a)

To access a Menu:

- Press the Menu Key in the middle (a).
- The Menu opens and no option is highlighted in the items available.
- Or,
- Press the Menu Key in the upper part (b).
- The Menu opens and the first item of the list is highlighted.

To select a different item:

- Press the high (b) or low (c) part of the Menu Key
- Or,
- Pass your finger on the keypad Scroll Bar.
- Or,
- Keep the Menu Key pressed in the middle (a) and rotate the wheel-holder shaft.

To enter the selection:

- Press the Menu Key in the middle (a)
- Or,
- touch OK.

Or, alternatively,

To cancel the selection:

- Press **ESC**; the menu list disappears.
- Press a different Menu key; the new Menu opens and what has been selected up to now is deleted.

Types of Menu

The Menus assigned to the same Key position can vary according to the operational screen in the different program phases.

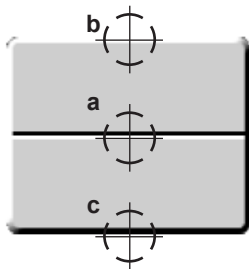

4-1a

Controls and displays

MAIN MENU

The Main menu **F1** in the Start Screen (**Fig.4-4**), contains the access items to the most common operational screens:

- 1 Access to BALANCING
- 2 Access to RIM DATA INPUT
- 3 Access to OPTIMIZATION/MINIMIZATION
- 4 Access to SETTINGS

The entire machine operational cycle and the user pre-settings can be managed from these screens.

The **F4** menu contains the following setting items:

- 5 Static unbalance Selection
- 6 Weights Fine Reading Selection
- 7 Grams / Ounces Selection
- 8 Weight Miser Selection (if present)

Menu **F6**

- 9 Access to COMPENSATION RUN

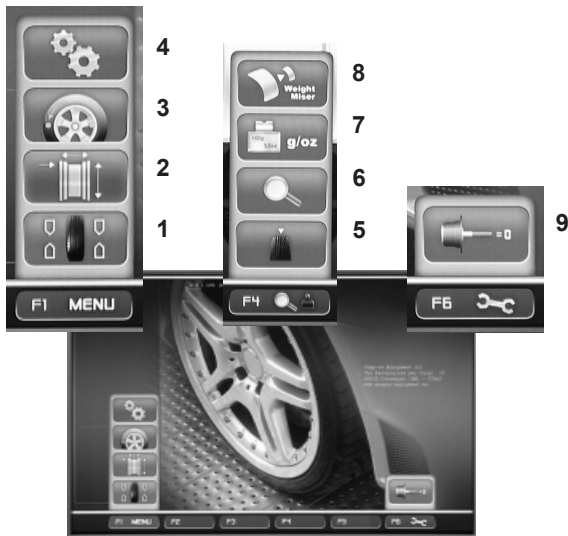

4-4

BALANCING

The **F1** Menu in the Balancing screen (**Fig. 4-5**), contains the access items to the following screens:

- 1 Access to RIM DATA INPUT
- 2 Access to OPTIMIZATION
- 3 Access to SETTINGS
- 4 Go back to the START SCREEN (HOME)

The **F2** Menu contains the various ALU selection items:

- 5 ALU 0 Selection
- 6 ALU 1 Selection
- 7 ALU 2 Selection
- 8 ALU 3 Selection
- 9 ALU 4 Selection
- 10 ALU 5 Selection

None of the Menu items can enable ALU P selections.

The **F3** menu contains the following items to select the Type of Vehicle settings:

- 11 CAR Selection
- 12 SUV Selection
- 13 VAN Selection

The **F4** menu contains the following setting items:

- 14 Static unbalance Selection
- 15 Weights Fine Reading Selection
- 16 Grams / Ounces Selection
- 17 Weight Miser Selection (if present)

Menu **F6**

- 18 Access to COMPENSATION RUN

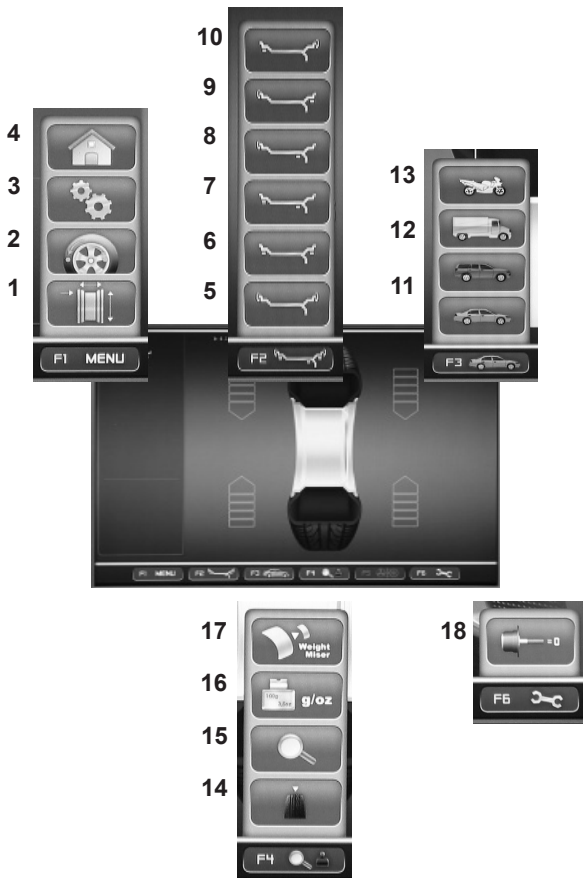

4-5

Controls and displays

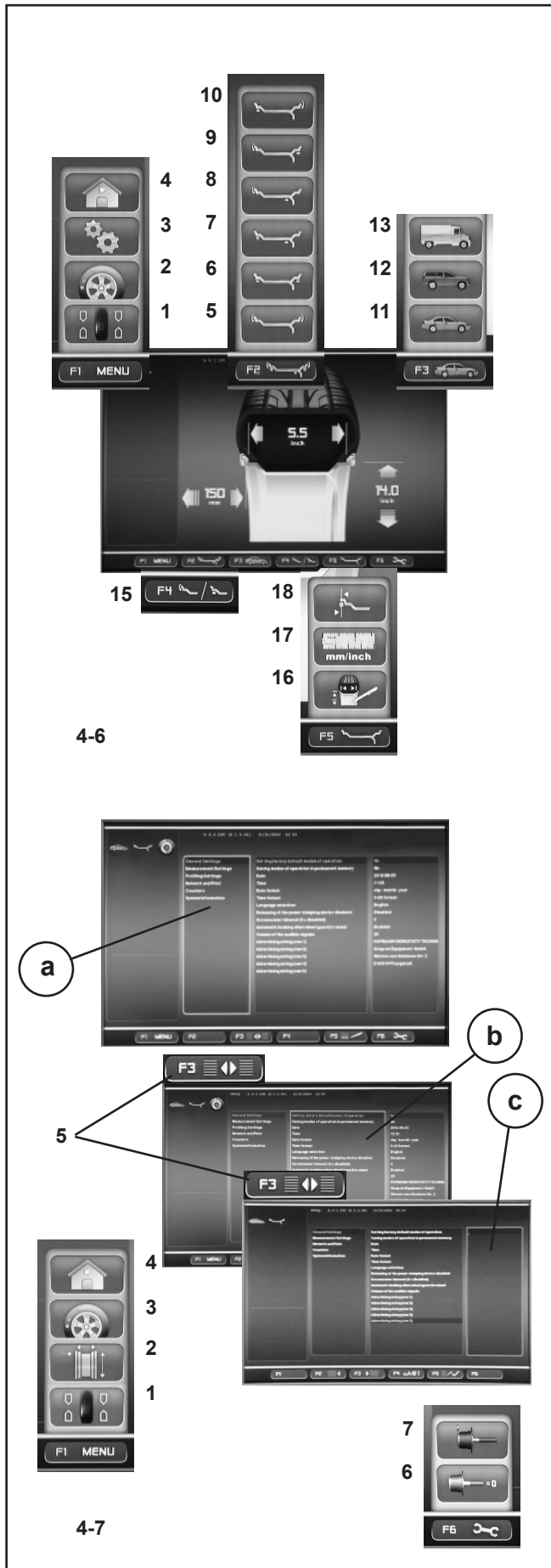

RIM DATA INPUT

The **F1** Menu in the Rim Data Input screen (**Fig. 4-6**), contains the following items:

- 1 Access to BALANCING
- 2 Access to Optimization
- 3 Access to SETTINGS
- 4 Go back to the START SCREEN (HOME)

The **F2** menu contains the different ALU selection items (enabled if in manual mode or after the measurement run):

- 5 ALU 0 Selection
- 6 ALU 1 Selection
- 7 ALU 2 Selection
- 8 ALU 3 Selection
- 9 ALU 4 Selection
- 10 ALU 5 Selection

Each Menu Item enables the selection for ALU and ALU P.

The **F3** menu contains the following items to select the Type of Vehicle settings:

- 11 CAR Selection
- 12 SUV Selection
- 13 VAN Selection

The **F4** Menu contains the following items:

- 15 *Easy Alu Toggle* Selection

The **F5** Menu contains the following items:

- 16 WHEEL PROFILE Input
- 17 MILLIMETERS / INCHES Selection
- 18 WEIGHTS MOVEMENT Selection (in MANUAL only)

FUNCTIONS

The **F1** Menu in the Functions screen (**Fig. 4-7**), contains the following items:

- 1 Access to BALANCING
- 2 Access to RIM DATA INPUT
- 3 Access to Optimization
- 4 Go back to the START SCREEN (HOME)

The **F3** (**5**) key in the Functions screen, is used to access the “**b**” and “**c**” panels used to select and change the options shown in the basic list “**a**”.

- 5 Alternate selection of panels “**b**” and “**c**”.

The **F6** Menu of the Functions Screen contains the Items to access the following procedures:

- 6 Access to COMPENSATION RUN
- 7 Access to USER CALIBRATION

Controls and displays

OPTIMIZATION/ MINIMIZATION

The Optimization /Minimization Menu (**Fig. 4-8**), is used to perform the relative procedure for the wheels being worked. An operational sequence, and control screens, guide the user through the entire operation.

The **F4** key is used to advance the procedure.



4-8

WHEEL PROFILES (in MANUAL only)

The Wheel Profiles item (**Fig. 4-9**) is recalled from the Rim Data Input Menu.

It is used to memorize and recall from a list, complete wheel data settings.

The **F6** Menu in the Rim Data Input screen with the item: **1, Fig. 4-9** Access to LIST OF WHEEL PROFILES

The desired wheel profile can be selected from the List screen, by scrolling the available Items with the Cursor. Press OK to activate the selection.



4-9

TEXT COMPOSITION

The Text Composition (**Fig. 4-10**), is used to set and memorize a five line text in the Start screen.

The text composition is performed directly in the Settings screen, at the *General settings* item.

Press **F3** to access the central panel in order to select with the OK key, one of the five lines available (line 1), (line 2), (line 3), (line 4) and (line 5).

In the panel on the right an underscore identifies the writing/change position on the line.

Use the Cursor to select the font to input.

Press **F4** to select the type of font and **F2/ F3** to move right or left along the line.

Press OK and then **F3** to input the text and move to the next line. Select another line and proceed in the same way.



4-10

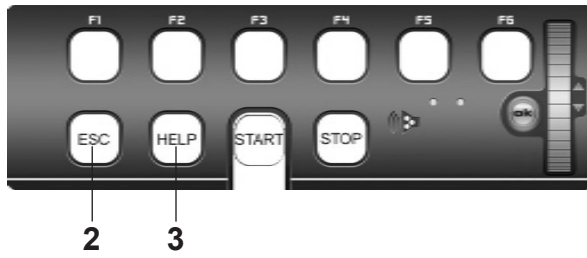

4-1

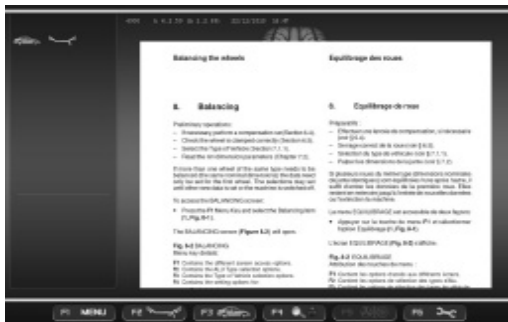

4-11

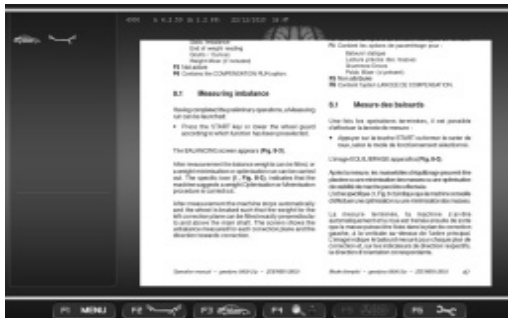

4-12

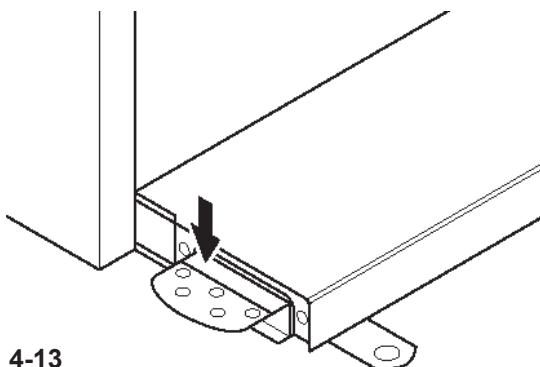

4-13

4.5 Help information

Help information explains the current action and, in the case of an error code, provides hints for remedy.

The information displayed relates to the current action. The complete help guide is available from the MAIN MENU screen (Fig. 4-1).

Display help information

- Press the HELP key (1, Fig. 4-1).

The first screen with help information appears, e. g. to the screen RIM DATA INPUT (Fig. 4-11).

- Press the HELP key once more to display the next screen with help information.

The second screen with help information to the screen RIM DATA INPUT (Fig. 4-12) appears. Continue to scroll through all the help screens until you return to the first page.

The help screens can be scrolled in both directions.

Scrolling backwards

- Press the upper part of the HELP key.

Note

You can only perform progressive movements in the help screens, in both directions, once screen at the time. On pressing the HELP key in the last screen with help information the display jumps to the first screen again.

Quit help information

- Press the ESC key (2, Fig. 4-1).

4.6 Main shaft lock

Fig. 4-13 Pedal of main shaft lock

The main shaft is locked when the pedal is depressed. This facilitates tightening or untightening of the clamping nut and retains the wheel in the correction position for correct fitting of the balance weights.

Note:

This lock is designed only to facilitate orientation of the wheel and must not be used for braking the main shaft.

Note:

On wheel balancers equipped with the quick-acting *Power Clamp* system: The pedal also controls the *Power Clamp*, for clamping the wheel on the balancer.

4.7 Detectors

The machine has a laser scanner to automatically acquire the wheel distance and diameter (inside of rim) **Fig. 4-14** and an ultrasound detector for the wheel width (outside of rim) **Fig. 4-15**.

The machine can optically indicate the precise point for fitting the weight on the rim, using a laser beam, the so-called laser pointer.

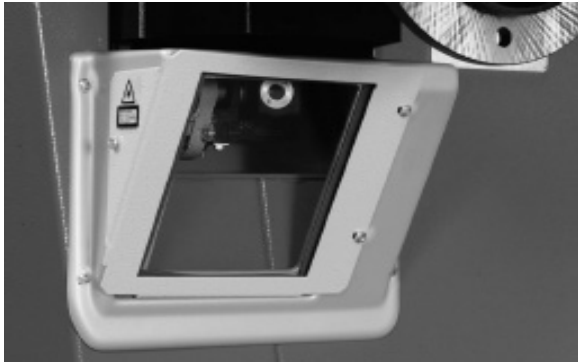

4-14



4-15

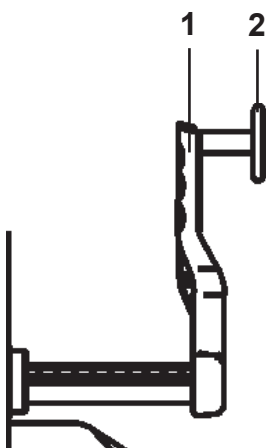

4-16

4.7.1 Gauge arm

Fig. 4-16

The arm is used to:

- Measure the rim distance only in MANUAL mode.

- 1 Arm, can be removed and folded upwards
- 2 Feeler rod used to measure the rim (Distance) for all types of profiles.

Switching on the machine

5. Switching on the machine

Please read through the operation manual and follow the instructions, especially when operating the wheel balancer for the first time.

- Always make sure the wheel guard is fully raised.
- Plug the mains cable plug into the power outlet (1, Fig. 5-1).
- Switch on the machine by the power switch (2, Fig. 5-1).

The electronic unit now performs a number of self-tests.

In this phase this message is displayed on the screen "WAIT: LOADING..." (Fig. 5-2).

As long as the machine is carrying out the self-tests, no inputs and no other operations whatsoever must be made. During this starting phase the machine must not be subjected to even the slightest vibrations.

Upon completion of the self-tests a melodious signal is heard, the screen shows the main menu (Fig. 5-3) and the machine is ready for operation.

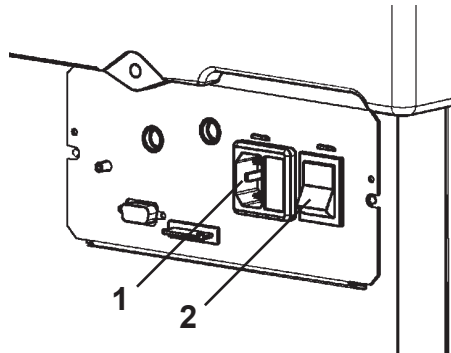

5-1



5-2



5-3

Fig. 5-3 Main menu

The menu fields of the function keys F1 to F6 show:

- F1** Access to BALANCING
- Access to ENTERING RIM DATA
- Access to OPTIMIZATION
- Access to SETTINGS
- F2** Not assigned
- F3** Not assigned
- F4** Not assigned
- F5** Not assigned
- F6** Access to COMPENSATION RUN

5.1 Status at switching on

The electronic unit is factory-adjusted to the following operating modes, available immediately after switch on:

- PROFILING mode
- Weight mode 1 (car wheel with nominal dimensions in inches, width 6.5" and diameter 15.0").
- Acquisition of rim data, unit of measurement: inches.
- Display of unbalance value with 5 gram increments.
- Suppression of minor unbalance readings (tolerance limit set at 3.5 g).
- Automatic wheel braking when guard is opened during the measuring run.
- Compensation of adaptor unbalance switched off.
- Start of measuring run by START key only.

5.2 Error codes at power on

If an error code occurs it must be acknowledged by pressing the STOP key or ESC key. No audible signal is given.

The following malfunction codes may occur at power-on:

Blue Screen

The communication between the microcontroller and embedded PC is interrupted.

- Check connecting lead

E3

The gauge arm for distance and rim diameter is not in home position.

- Move gauge arm to its home position. Press the STOP key or the ESC key.

E4

The width gauge arm is not in home position.

- Move gauge arm to its home position. Press the STOP key or the ESC key to continue.

E89

A key is jammed or the pedal switch is closed.

- Find and release jammed key.

Or:

- Press STOP or ESC-key to check the switch.

If the error cannot be remedied, the pedal function is switched off by pressing the STOP key or the ESC key. Call service.

E92

During the second attempt the gauge arm for distance and rim diameter was still not in the home position. Both gauge arms are rendered inoperative.

- Wait 3 seconds, or press the STOP key or the ESC key to continue.

E93

During the second attempt the width gauge arm was still not in the home position. The gauge arm is rendered inoperative.

- Wait for 3 seconds, or press the STOP key or the ESC key.

E145

The contents of both permanent memories are different, but both contain valid data.

Switching on the machine

E360

Wheel profiler position calibration required

Possible causes:

- the camera controller board has been replaced
- at least one scanner has been replaced
- the calibration data is missing
- the scanner cables have been swapped

Corrective actions:

- check the connections
- calibration procedure (C122) is required to calibrate the actual position of the laser scanners with respect to the balancer reference plane.

E361

Wheel profiler not present or not responding during self test

The balancer controller board was not able to communicate with the camera controller board during power on self test.

Possible causes:

- the camera controller board is missing or damaged
- the flat cable connecting the keyboard, the balancer controller board and the camera controller board is unplugged, damaged or missing.

Corrective actions:

- check the camera controller board
- check the connections
- re-install the camera controller board software.

E900

Unknown machine model.

E901

The machine is not calibrated.

Switching on the machine

H82

The self-test was disturbed (e.g. by rotating the wheel).

The message is displayed for 3 seconds, after which the measurement is repeated (max. 10 times), or aborted by pressing the STOP key or the ESC key.

H948

H949

Fault during self-test at start-up.

The firmware is not aligned with the User Interface version currently in use.

Note:

Wheel balancer operation is not compromised.

- You can continue using the machine.
- Consult the technical assistance department for further information.

Fatal error codes

The self-test program has detected an error and displays a alphanumeric code consisting of six digits and/or letters.

C10 800

Line voltage under 170 V. Balancing is feasible if the motor can drive the main shaft to the measuring speed. Wheel data may be lost.

- Bring the line voltage to within a range of 200 - **230** - 240 Volts with an input transformer.

C10 801

Line voltage over 265 V. Damage to the electronic unit of the machine is likely!

- Turn off power switch!
- Bring the line voltage to within a range of 200 - **230** - 240 Volts with an input transformer (ref. 6705 902).

Any damage resulting from repeated occurrence of this error code is not covered by the guarantee.

C10 804

Line voltage over 275 V. Damage to the electronic unit of the machine is likely!

- Turn off power switch!
- Bring the line voltage to within a range of 200 - **230** - 240 Volts with an input transformer (ref. 6705 902).

Any damage resulting from repeated occurrence of this error code is not covered by the guarantee.

Clamping the wheel

6. Clamping the wheel

Fig. 6-0 A

The main shaft lock pedal has two functions

PEDAL DOWN: Stopping rotation

The shaft angle is locked when the pedal is depressed. This lock is designed only to facilitate orientation of the wheel and must not be used for braking the main shaft.

PEDAL UP: POWER CLAMP lock

The pedal also controls the POWER CLAMP, for clamping the wheel on the balancer.

Fig. 6-0 B

Power Clamp with jaws fully open.

Fig. 6-0 C

Power Clamp with jaws fully closed.

By changing the mode of operation it is possible to reverse the direction of actuation of the pedal.

6.1 Fitting the *Power Clamp* device

Figure 6-1

Note:

If the machine is retooled for the power clamping device, reset the mode of operation **C22** to status On "Releasing the power clamping device is disabled".

Move the clamping jaws to unclamped position. Unscrew the taper nut and place aside. Remove the special clamping means, if mounted, from the cone of the main shaft. Mount the basic body of the clamping device, screw it onto the tie rod by turning it to the end of the thread and then release it again by a quarter of a revolution. Slide the basic body by hand onto the cone, inserting the screw heads through the bayonet disc. Turn the basic body until the screw thread is contacting the bayonet disc. Slide on the clamping sleeve with clamping head and clamp. Tighten the screws evenly with an open end wrench, width across flats 13 mm.

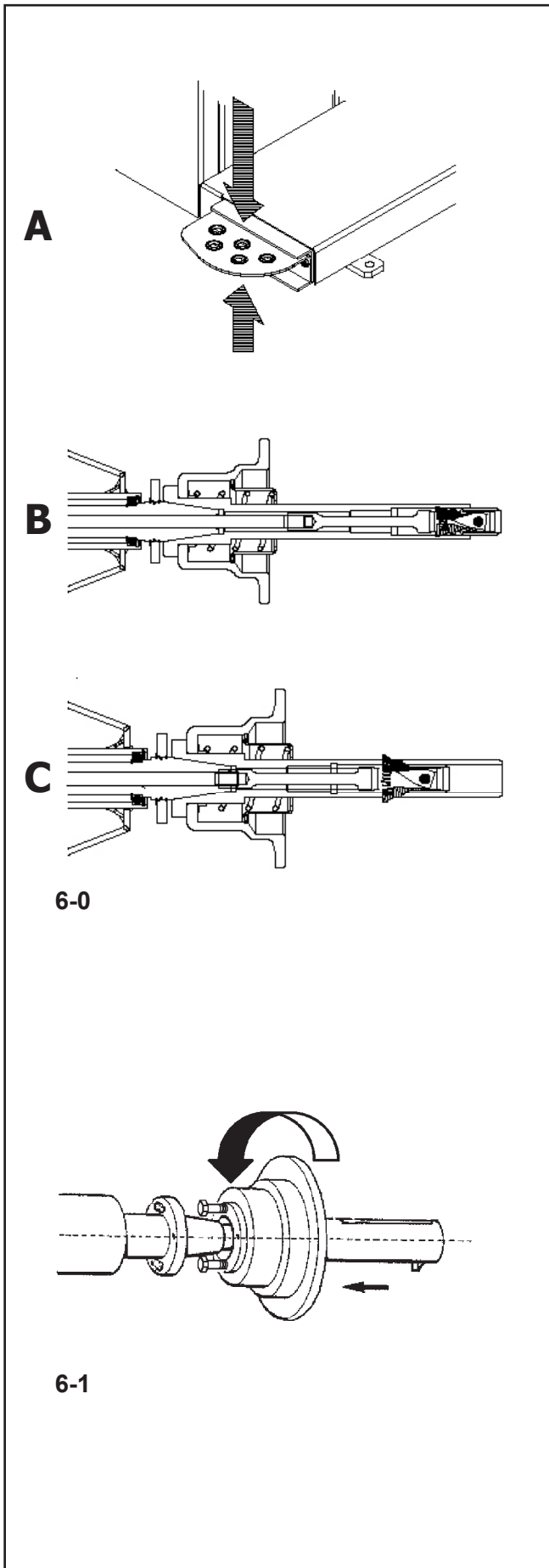

Clamping the wheel

6.2 Clamping / unclamping the wheel

The electric controller is so designed that after turning on the mains switch the clamping jaws remain in their instantaneous position and any change must be effected intentionally by actuating the pedal.

6.2.1 Clamping the wheel

Note:

Before clamping the wheel make sure the contact surfaces on wheel adaptor and rim are free from dirt and grease.

- Move the clamping jaws to **unclamped** position (**Fig. 6-2**).
- Slide the centring cone or centring ring (chosen function of centre bore diameter of the wheel) on the main shaft (**Fig. 6-3**).
- Position the wheel to be clamped on the centring cone or ring, hold approximately in vertical position and slide the clamping sleeve and clamping means (clamping head, pressure ring, or flange plate) on the chuck (**Fig. 6-4**).
- Press the clamping sleeve and clamping means firmly against the wheel and lift the pedal (**Fig. 6-5**).
- Check for proper clamping prior to the measuring run.

Notes

If the pedal is actuated once again during the clamping process, clamping is interrupted and the clamping jaws return to unclamped position. Clamping can also be interrupted by operation of the STOP or the ESC key.

With the wheel balancers with power clamp, the screen RIM DATA INPUT comes up automatically after every clamping operation.

With every power clamp, measurement can be started only when the wheel is clamped and the wheel guard closed.

6.2.2 Unclamping the wheel

Note:

While the jaws unclamp, hold the wheel so that it will not tilt when unclamped.

- Lift the pedal (**Fig. 5**).
- Remove the clamping sleeve from the chuck.
- Remove the wheel.

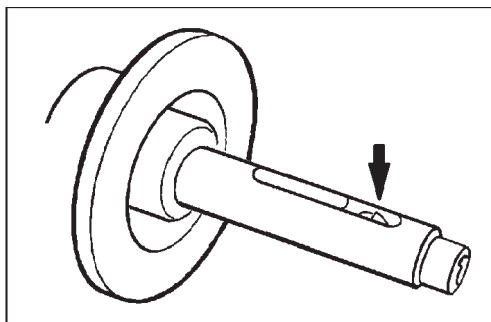

6-2

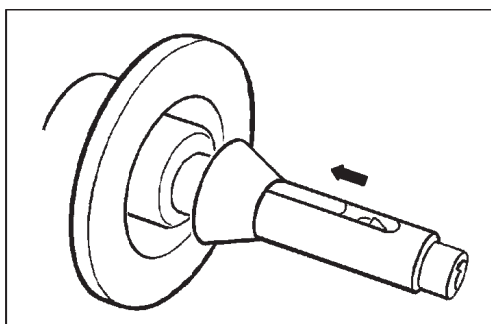

6-3

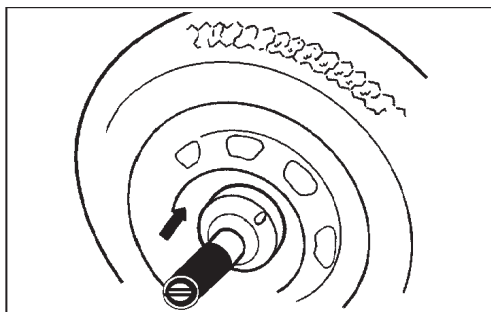

6-4

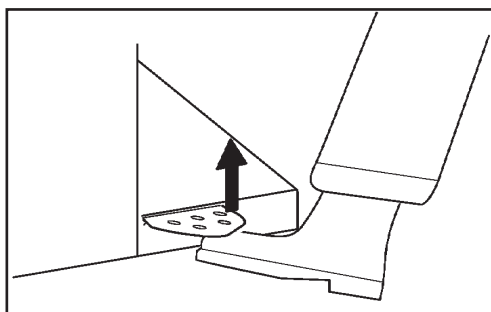

6-5

Clamping the wheel

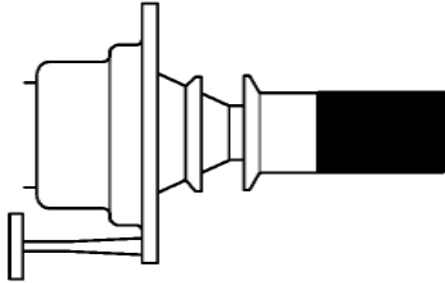

6-6



6-7

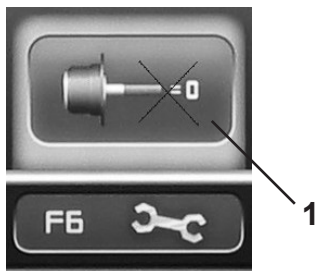

6-8

6.3 Preparing for calibration

For readjustment of a p balancer the clamping device must be clamped without wheel.

- Fit the small centring cone, the middle centring cone and the clamping sleeve without clamping head (**Fig. 6-6**) on the chuck.
- Start the clamping process.

The device should be calibrated exactly as described in the relevant chapters.

6.4 Compensation Run

All clamping and centering means are balanced in our works to within a certain tolerance.

To compensate for any residual unbalance that might be left in the clamping means, it is recommended that an electrical compensation run be performed after switching on the machine or after changing the wheel adaptor, (also see § 6. Changing modes of operation). This mode cannot be transferred into the permanent memory.

- Fit the clamping device properly on the balancer shaft. Do not fit the wheel.
- Starting from the screen main menu (**Fig. 6-7**) press the menu key **F6** for electrical compensation of unbalance in clamping means (**1, Fig. 6-7**).
- Start the compensation run with the **START** key.

The compensation run takes longer than a regular measuring run. After the Compensation Run, an icon in the status Bar indicates the Compensation Active status.

This mode of operation is retained until deleted by pressing menu key **F6** (**1, Fig. 6-8**) again, by starting readjustment or an optimization run, or by switching off the machine.

Wheel data Reading

6.5 Gauge calibration

Note:

The Gauge should be used to measure the wheel-machine distance only in MANUAL Mode.

The internal Gauge is used only to measure the distance between machine and wheel (**Offset**).

Fig. 6-9 Internal Gauge calibration for rim distance.

- 1 Internal gauge with gauge head
- 2 Gauge head (feeler)
- 3 Telescoping point to read the distance **X**
- 4 Graduated scale.

Figure 6-10

Determining the distance by measuring with gauge arm.

Application:

- position the Gauge Head on the rim, in the exact point shown in the "Gauge Position" chapter.
- Read the distance value on the graduated scale of the rod, at the Telescoping point.
- Recall the Rim Data Input function in the Menu and proceed as shown in the 7.3.3.2 "Rim/machine distance input" chapter.

The Gauge calibration is used to determine the exact distance. Entering the distance manually excludes the use of the *EasyAlu* function.

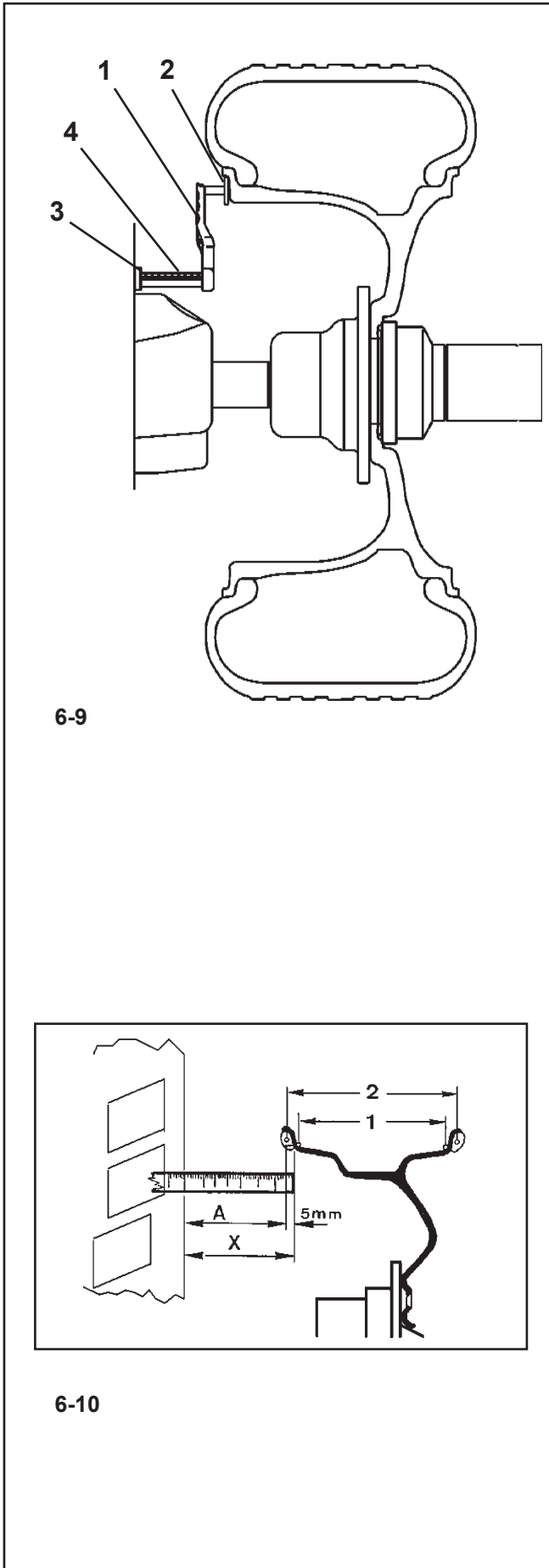

6.5.1 Gauge head application on various Wheel types

In order to be able to determine unbalance in a single measuring run, the rim dimensions have to be entered correctly. Therefore proceed with utmost care and as is shown in the Figures when applying the gauge head on the rim in the desired weight fitting position. Incorrect application will result in deviations of measured values and consequently inaccurate results of the measuring run.

Fig. 6-11a to 6-11f

show correct application (with and without adhesive weight) of the gauge head on various rims and for various weight fitting positions.

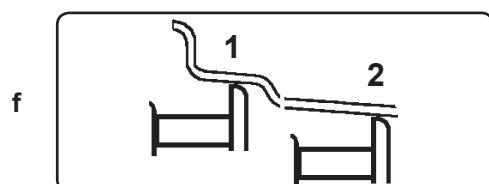
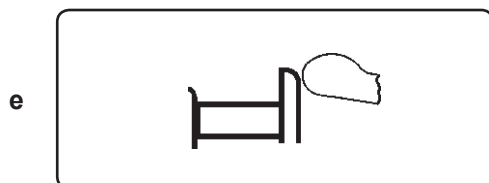
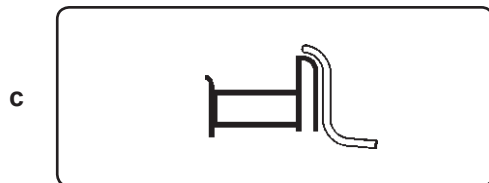
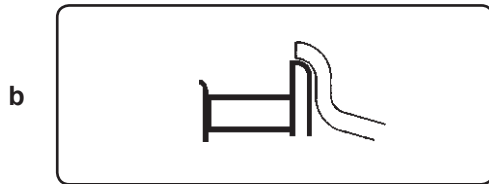
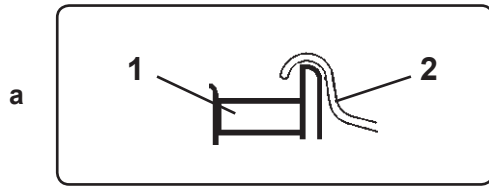

6-11

Fig. 6-11 a Standard wheel – Steel rim

1 Gauge head

2 Rim

Fig. 6-11 b Standard wheel – Alloy rim

Fig. 6-11 c Light-truck wheel – Steel rim

Fig. 6-11 d Light-truck wheel – 15° taper steel rim

Fig. 6-11 e Alloy wheel - Rim without a housing for clip-on weights

Fig. 6-11 f Alloy wheel – Adhesive weights

1 Left correction plane, first application position.

2 Right correction plane, second application position.

Wheel data Reading

6.5.2 Reading positions for various Alu types

The Gauge should be used to select the various Alu only in **MANUAL Mode**

Fig. 6-12 shows the corrected reading positions of the measurement gauge on different types of rim (1), depending on the required weight application positions (2); adhesive and clip-on weights.

* Select the menu key:

F4 to recall the required ALU P weight positions.

Fig. 6-12

- = Point of application of gauge arm (1)
- /☞ = Given weight position (2)

normal Normal weight positioning. Clip-on weight positions on the rim flange.

Alu 1 Adhesive weights applied symmetrically to the rim flanges with NOMINAL weight positioning.

Alu 2 Adhesive weights - Adhesive weight on rim flange, adhesive weight hidden in rim disc with NOMINAL positioning.

Alu 2P Adhesive weights - Adhesive weight on rim flange, adhesive weight hidden in rim disc.

Alu 3 Clip-on weight on left rim flange, adhesive weight hidden in rim disc.

Alu 3P Clip-on weight on left rim flange, adhesive weight hidden in rim disc.

Alu 4 Balance clip fitted on left rim flange, adhesive weight attached to right bead seat.

Alu 5 Balance clip fitted on right rim flange, adhesive weight attached to left bead seat.

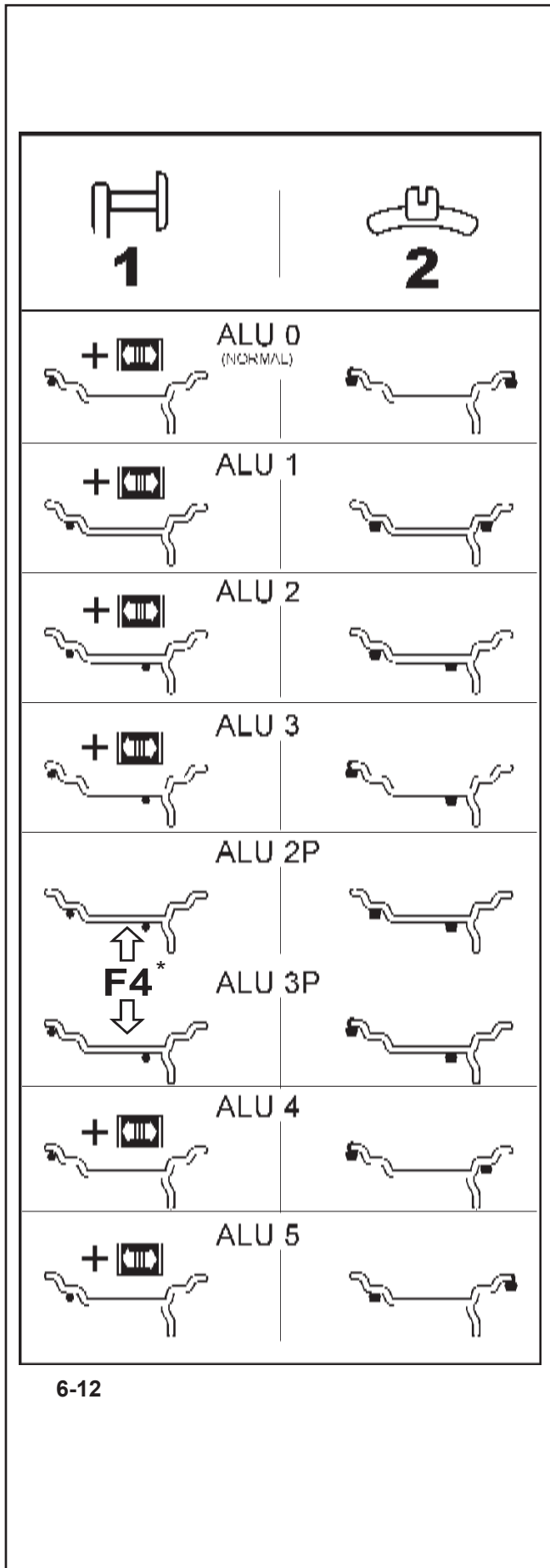

* F4 = Easy Alu Toggle

7. Operating Modes

The various operating modes have specific properties and objectives. The operator, based on the type of wheel he is working on, must decide the desired result:

- Select the Operating Mode (Chapters 1.4.2 & 10).

With the **MANUAL Mode** you can:

- Perform a balancing based on nominal wheel data.
- Use the arm for the entire wheel.
- Use the Menus to set the wheel data.
- Use the Menus to set a specific ALU.
- Use the Special Dimensions function.
- Use the Wheel Profiles function.

With the **PROFILING Mode** you can:

- Perform the balancing cycle automatically.
- Read the type of rim.
- Use the *Rim Data Freeze* function.
- Automatically count the number of spokes.
- Automatically read the position of the spokes.

7.1 MANUAL Mode - Settings

To establish the imbalance value the machine must have been given the following basic information:

- **Vehicle type** (depending on rim type)
- **balancing mode** (weight fitting position on rim)
- **Rim width** and **diameter** (nominal or effective)
- **Distance** between machine and left correction plane

This data can be entered one at a time by recalling the various options in the respective menus. This allows the machine to calculate imbalances on the basis of NOMINAL (theoretical) data.

7.2 Rim dimension reading and setting and Alu Mode

Important

For the Alu0, Alu1, Alu4 and Alu5 modes the width of the rim must always be entered manually on the keyboard.

The OK indication and recommendation for optimisation, as well as the optimisation procedure itself, will only be accurate if the rim width has been correctly entered.



7-5



7-5.a

ALU 0



ALU 1



ALU 2/2P



ALU 3/3P



ALU 4



ALU 5



7-6



7-6a

Rim width detection

To set rim width:

- Access the ENTERING RIM DATA screen and select the EDIT MEASUREMENTS item (Fig. 7-5) by selecting the Menu key F5.
- Measure the width with the appropriate gauge or read the data stamped on the wheel.
- Press the menu key F3 (2, Figure 7-5a) and scroll until the required value is reached.
- Press the menu key F3 to set the value.

If the internal position is read first, all the wheel dimensions required and the Alu type are read on the basis of the contact points chosen by the operator on the rim.

Rim width, distance and the rim diameter are read out on the screen RIM DATA ENTRY. The machine automatically detects the type of Alu according to the contact points on the rim worked on; Alu0, Alu1, Alu2/2p, Alu3/3p, Alu4 or Alu5 (Fig. 7-6).

An ALU Type in use identification icon will be displayed in the Status Bar at top left; in the example, Alu 2P (Fig. 7-6a).

Note:

After the run, the Alu selection can be changed and the values re-calculated as required. The machine automatically recalculates the results. Another measuring run is not required.

- On the BALANCING screen (Fig. 7-5) press the F2 Menu.

7.2.2 “Easy Alu Toggle” function

Automatic correcting the Alu proposed

Depending on the gauge contact points on the rim, the machine has interpreted a probable Alu mode required by the user. Every time the Alu presented by the machine does not correspond exactly to the one required it can be corrected using the “Easy Alu Toggle” function.

- Press the **F4** key (**Fig. 7-7**) if you want the alternative Alu mode to that suggested for the rim being worked on.

Note:

The Alu can only be changed before the run or before the imbalance display request (gauges are applied after the run to select a completely different Alu).

The position for adhesive weights can be precisely located with the Auto-Stop-System after the measuring run.

7.3 Menu settings

The wheel dimensions to be entered are usually given on the rim (in inches or mm on standard wheels, in mm on TD or TRX wheels). Rim diameter is also given on the tyre. Read the rim dimensions before clamping the wheel on the balancer

To make a setting using the Menu, access the BALANCING screen (**Fig. 7-9**), or the RIM DATA ENTRY screen (**Fig. 7-9**):

- On the main Menu (**Fig. 7-8**) press the **F1 MENU** key and select the RIM DATA ENTRY.

The RIM DATA ENTRY screen (**Fig. 7-9**) will open.

Note:

All the basic selections can be made in the same way from the BALANCING and RIM DATA ENTRY menus.

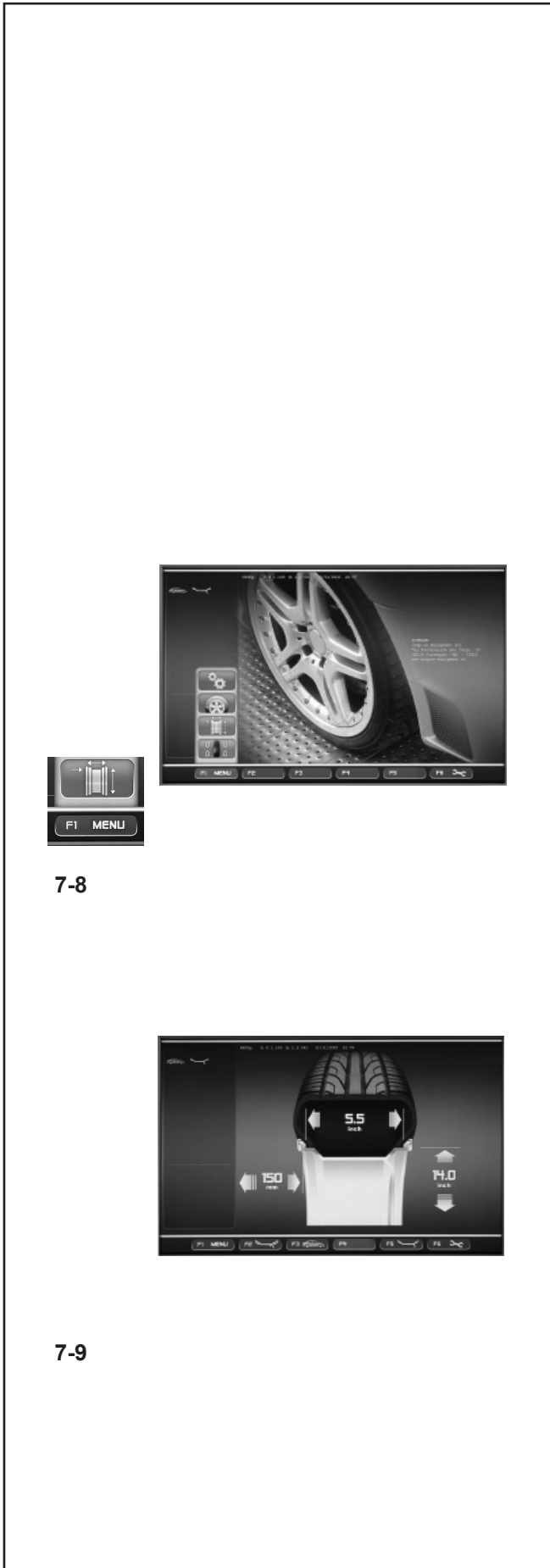

7-8

7-9



7-10

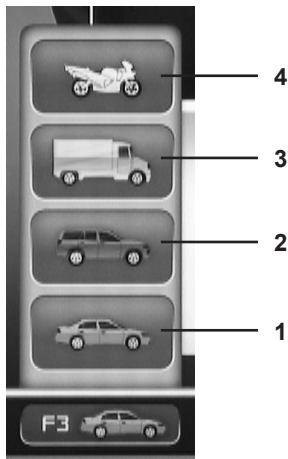

7-11



7-12

7.3.1 Selecting the Type of Vehicle

When the unit is started it shows the “Vehicle” selection **1**.

In MANUAL mode the vehicle must always be selected by the operator.

- On the BALANCING and RIM DATA ENTRY screen **Fig. 7-10** press the menu key **F3 Fig. 7-11** to select the Type of Vehicle.
- Select the TYPE OF VEHICLE item according to the rim on the machine.

Fig. 7-11 Types of Vehicle

Assigned Menu items:

- 1 Standard vehicle wheel (car)- nominal dimensions in inches. The unit of measure (**inches**) is displayed. Normal and Alu 1 to Alu 5 weight positioning can be selected. To select a standard wheel with nominal dimensions in mm - TD or TRX wheel, you should select the **mm/inch** option from Menu **F5** in the RIM DATA ENTRY screen **Fig. 7-10**.
- 2 SUV vehicle wheel - nominal dimensions in **inches**.
- 3 Light industry vehicle wheel (Van)- nominal dimensions in **inches**. Executable steps are expressed in the “Product Requisite” table at the end of the manual. The threshold value for suppression of minor unbalances is automatically doubled when this type is chosen and the resolution of the amount reading set to 10 g and 5 g respectively. Thresholds for WeightMiser correspond to 1.5 times this value (see specific Weight Miser™ user’s handbook).
- 4 Motorcycle wheel - nominal dimensions in inches, with imbalances resolved and suppressed in the same way as car wheels. Consult executable steps in the “Product Requisite” table.

When the selection has been made, a Type of Vehicle in use identification icon will be displayed in the Status Bar at top left **Fig. 7-12**.

7.3.2 Manual ALU selection

- On the BALANCING and ENTERING RIM DATA screen (Fig. 7-10) press the F2 MENU key (Fig. 7-14) to select a specific ALU mode.
- Select the ALU item corresponding to the required weight location.

Figure 7-14 ALU types

Assigned F2 Menu items:

- 1 ALU 0 (normal) - Using clip-on weights on the internal and external sides of the rim.
- 2 ALU 1 - Using adhesive weights on the internal and external rim flange.
- 3 ALU 2 - Using an adhesive weight on the internal rim flange and an adhesive weight on the rim disc. Both weights will be invisible from the outer wheel.
- 4 ALU 3 - Using a clip-on weight on the inside and an adhesive weight on the rim disc. Both weights will be invisible from the outer wheel.
- 5 ALU 4 - Using a clip-on weight on the inside and an adhesive weight on the external rim flange.
- 6 ALU 5 - Using an adhesive weight on the internal rim flange and a clip-on weight on the outside of the rim.

A Type of ALU in use identification icon Fig. 7-13 will be displayed in the Status Bar at top left.



7-10



7-13

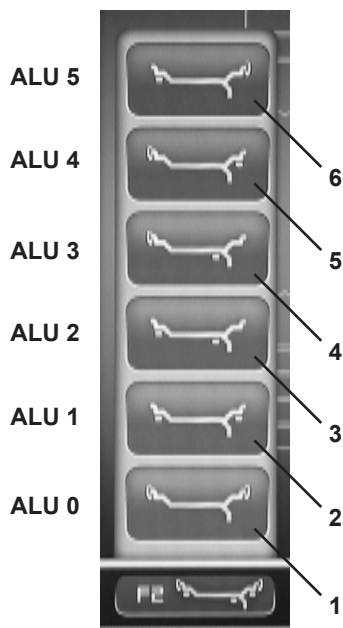

7-14

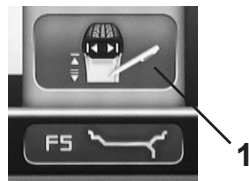

7-15

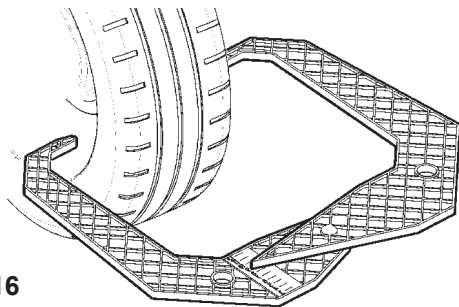

7-16



7-17

7.3.3 Entering rim measurements manually

Entering rim measurements manually results in balancing cycles based on nominal data outside of the *EasyAlu* function.

If data is changed manually, before or after a run, the system immediately exits the automatic function and inhibits real data based measurements (Alu P).

- Access the ENTERING RIM DATA screen and select the EDIT MEASUREMENTS item (1, Fig. 7-15) by selecting the Menu key F5.

7.3.3.1 Entering the rim width

If the width of the rim cannot be measured, if a standard rim is present it can be measured using the width gauge (Figure 7-16 - reg. no. EAA0247G21A).

To set rim width:

- Measure the width with the appropriate gauge or read the data stamped on the wheel.
- Press the menu key F3 (2, Figure 7-17) and scroll until the required value is reached.
- Press the menu key F3 to set the value.

7.3.3.2 Entering the rim/machine distance

If automatic determination of the distance rim/machine is not possible (error code E 92), the distance can be determined manually.

Fig. 7-18 Determining distance by measurement

- Rest the measuring arm gauge on the edge of the rim, read the value on the graduated scale.

- Press the menu key F2 (1, Figure 7-17) and scroll until the required value is reached.

- Press the menu key F2 to set the value.

7.3.3.3 Entering the rim diameter

If automatic determination is not possible (error code E92), the rim diameter can be determined manually .

- Read the nominal diameter on the rim or tyre and note it down.
- Press the menu key F4 (3, Fig. 7-17) and scroll until the required value is reached.
- Press the menu key F4 to set the value.

7.4 Special Dimensions mode

- In the ENTERING RIM DATA screen press the menu key **F5**, then select the Special Dimensions item (**1**, **Fig. 7-15**).

The ENTERING RIM DATA screen appears where the weights highlighted on two planes appear in a square shape (**Fig. 7-20**).

Note:

The Special Modes function is not used for the normal balancing procedures but only if it is not possible to use a programmable weight position (e.g. in the case of special wheels), with complex dimension parameters beyond the automated mechanisms on the machine.

The ALU 0 mode is automatically recalled when selected.

The dimensions are always displayed in millimeters.

- Measure directly on the wheel to be balanced the distance **X** and the effective compensation measurements using the gauge (**Figure 7-21**).

- Press key **F2**, **F3** or **F4**, according to the dimension you wish to alter.

The value involved in the alteration takes on a coloured identification frame.

- Using the scroll cursor change the value, until the value displayed corresponds to the value measured.
- When this value is reached press the same key again.

The rim dimensions are now entered completely. The input is retained until a new input is made or until the machine is turned off.

7-15

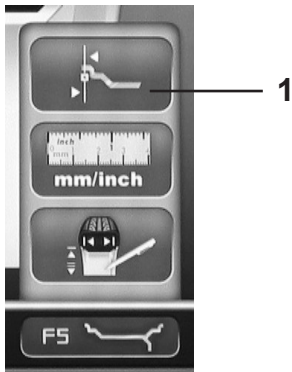

7-20

7-21

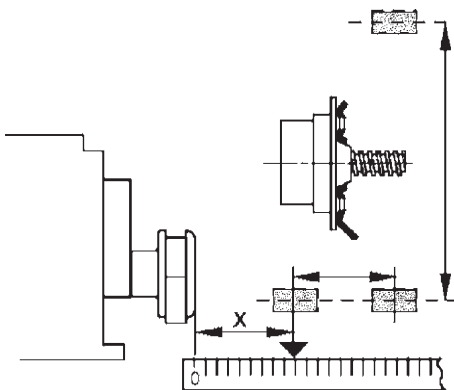

7.5 Wheel Profiles function

To balance more than one wheel of the same type and with the same nominal dimensions, simply set the data for the first wheel only. The data set then remains until other new data is set or the machine is switched off.

To make the wheel parameters available permanently use the WHEEL PROFILES function.

The wheel profiles function enables you to memorize the values of certain wheel types that are often balanced in the garage. Naturally this bypasses the task of repeatedly setting wheel data. This function is particularly useful for workshops that carry out series fitting of tyre/rim assemblies or frequently handle the same wheel types (e.g. workshops that offer rims for retrofitting).

The once-only storage of the rim data in the profiles guarantees that the same correction planes are always used, in particular for alloy wheels, thus providing consistent balance quality.

The function can be used to save the following data:

- Nominal wheel dimensions
- Values measured
- Position of weights (Modo Alu)
- Type of Vehicle
- Traceability positions (list from 1 to 9)
- Number of spokes (if loaded previously)

Fig. 7-22 PROFILE

Assignment of menu fields:

F1 Access to Basic Menu

F2 Not assigned

F3 Saves current profile in permanent memory

F4 Not assigned

F5 Applies a wheel profile selected from the memory

F6 Not assigned



7-22

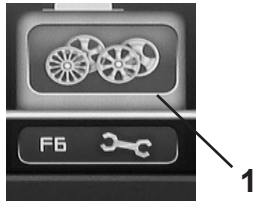

7-23

7.5.1 Saving a Wheel Profile

Up to 9 wheel profiles can be saved.

- Clamp the wheel you wish to save the profile of.
- Set and acquire all the wheel data including the number of spokes and the *EasyAlu* and *Easy Alu Toggle* readings if an Alu P is required.
- Press the menu key **F6** in the ENTERING RIM DATA screen and select the Wheel Profiles item (**1**, **Fig. 7-23**).

The WHEEL PROFILES screen (**Fig. 7-24**) will open.

The current wheel profile data is highlighted in a line on its own at the bottom of the page.

- In the 9 position list, use the Scroll command to choose the current profile registration position.
- Press the **F3** key to save data.

The data is now saved permanently in the chosen position and can be recalled when required.

Note:

If the profile is overwritten with other data it is no longer shown in the list.



7-24

7.5.2 Recalling a Wheel Profile from the memory

- Clamp the wheel to the balancer.
- Press the Menu key **F6** in the ENTERING RIM DATA screen and then select and press the WHEEL PROFILES key (**1**, **Fig. 7-23**).

The WHEEL PROFILES screen (**Fig. 7-24**) will open.

- Use the Scroll command to select the profile indicated for the wheel on the machine.
- Press the **F5** key to apply the data selected.

The ENTERING RIM DATA screen (**Fig. 7-25**) will open and show the data recalled.

- Check that the settings in the Indications Field and Status Bar panel are correct.

The machine is now ready to proceed with the measuring run (Chapter 8.1).



7-25

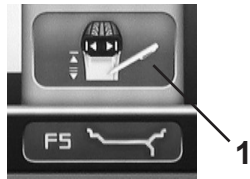

7-15

7.6 Correction of inputs after measurement

If incorrect data and/or incorrect wheel type or balancing mode were entered for a measuring run (Type of Vehicle, Alu Mode):

To reset the corrected rim dimensions and/or the corrected measurement methods

- Return to the ENTERING RIM DATA screen (Menu F1).
- Press the **F5** Menu key to select the item (**1, Fig. 7-15**).

The EDIT MEASUREMENTS function screen opens so proceed as described in Chapter 7.3.3.

At the end of the process the electronic control unit acquires the new settings, processes and displays the corrected measurement values in the BALANCING screen without having to launch another run.

Note:

Entry of a new datum via manual setting involves exit from any preselected Alu P mode. The machine will present the nominal Alu corresponding to the Alu P set before.

7.7 Axial Run-out test

Prior to the measuring run check the wheel for radial and lateral run-out. If considerable run-out is observed the tyre may be incorrectly fitted on the rim. In this case, the wheel should not be balanced.

When supplied from our works the machine is programmed such that the wheel is braked automatically when the wheel guard is raised (mode of operation "automatic braking when wheel guard is raised" set to "enabled").

Observation of the wheel is only possible when this mode of operation is set to "disabled" (no braking of wheel by raising of wheel guard, see § 10. Changing modes of operation).

If the mode is set to "disabled":

The wheel rotates when the wheel guard is open. Make sure that the wheel is not blocked by tools or the like. Wear safety goggles and tightly fitting working clothes.

- If the wheel clamped on the balancer is to be checked for visible radial and/or lateral run-out, perform a visual check by lowering the wheel guard and pressing the START key, prior to the actual measuring run.
- Then raise the wheel guard and observe the wheel for radial and lateral run-out while it slows down.
- Finally brake the wheel by operation of the STOP key.

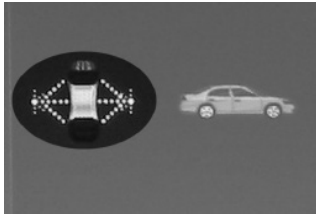

7-20



7-21

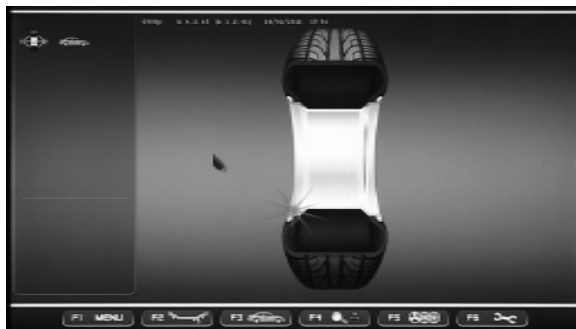

7-22



7-22a

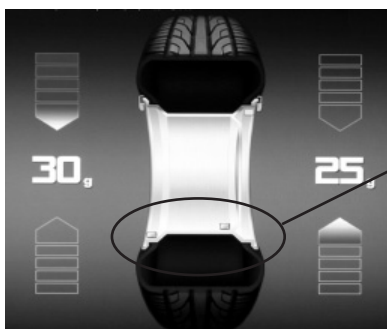

7-23

7.8 “PROFILING” balancing

The following instructions describe the specific functions of the wheel balancer in PROFILING mode.

The icon shown in fig. 7-20 indicates the PROFILING mode is active. The unit operates in Automatic Mode.

When the “PROFILING” mode is set with the set up panel, the machine performs the automatic wheel data reading procedure and the user does not have to perform any setting before the measuring run.

This section sets out the specific functions of the “PROFILING” mode and only the Menu items that refer to this mode.

For information about the other items and icons, refer to the basic chapter “4. Control Elements”.

The balancer displays the start screen at power-on. The screen in fig. 7-20 appears automatically on the monitor after clamping the wheel.

During the wheel measuring run the screen in fig. 7-22 appears and at the end the weights shown can be:

- suggested (yellow)
- or
- possible alternatives (grey) in the 6 o'clock zone, precisely where the laser beam indicates they should be applied (1, Fig. 7-23).

If the Spokes Count is active, the icon in fig. (2, Fig. 7-22a) is displayed during the measuring run.

The possible application of the weights in ways other than that suggested by the machine is indicated by the grey weights in the positions compatible with the rim configuration detected.

Note:

The change in the position of the weight is saved by the machine, then automatically suggested for all subsequent wheels with the same dimensions. The selection is deleted when the machine is switched off.

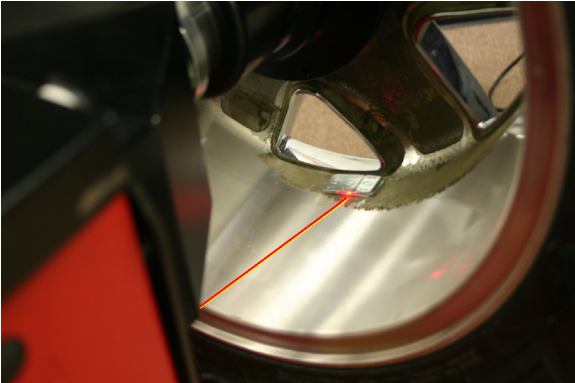

7-24



7-25

F2 - POSITION CHANGE:

With the **Laser Pointer** mode active (Fig. 7-24), the **F2** key opens the Menu with the Item used to change the weight position during the application phase.

Once you have reached the adhesive weight application position (green arrows), change the weight position as follows:

- Press the **F2** key in the Menu and select **Laser Pointer** (1, Fig. 7-25)..
- Manually rotate the wheel to change the position of the weight indicated by the pointer.
- Press the **F2** key in the Menu and select **Laser Pointer** to enter the position reached.

Note:

The relocation causes a variation of the position and value of both weights. As the change can be performed on both planes, the right weight (close to the rim flange) is usually applied first, due to the fact that it needs to be moved more often.

Note:

The change in the position of the weight is saved by the machine, then automatically suggested for all subsequent wheels with the same dimensions. The selection is deleted when the machine is switched off.

7.8.1 Wheel Data Freezing “Rim Data Freeze”

The “Rim Data Freeze” function allows you to save the data detected on a first rim, of a group of identical wheels (usually four) to be balanced.

This function enhances machine performance since it reduces the data acquisition time for the subsequent identical wheels after the first.

Note:

This feature is only available in AUTOMATIC Mode: (PROFILING).

How the function works

- Clamp the first wheel.
- Perform a run.

During the run, all wheel data is defined by the unit by means of the automatic remote gauges; if necessary the operator can change the values suggested by the machine

After the first wheel has been balanced, before clamping another wheel from the set on the machine, you can freeze the rim data by selecting *Rim Data Freeze* (1, Fig. 7-27) in the F2 Menu. The (2, Fig. 7-27a) icon is immediately displayed.

The subsequent wheels will be balanced without running the wheel profile detection.

The use of the previously “frozen” data, reduces the cycle time considerably.

If previously enabled, the laser pointer function can be used for weight placement.

This function is directly available at the end of the wheel measuring run and can be activated:

from the BALANCING screen page or from the RIM DATA INPUT screen page

- press F2 and select *Rim Data Freeze* (1, Fig. 7-27).

To cancel the function:

The frozen rim data can be deleted at any time, by pressing the F2 key again and selecting *Rim Data Freeze* (1, Fig. 7-27).

In this way the padlock icon disappears (3, Fig. 7-27b), to indicate that the rim scan is allowed and it will be necessary for the wheel data acquisition at the next wheel run.

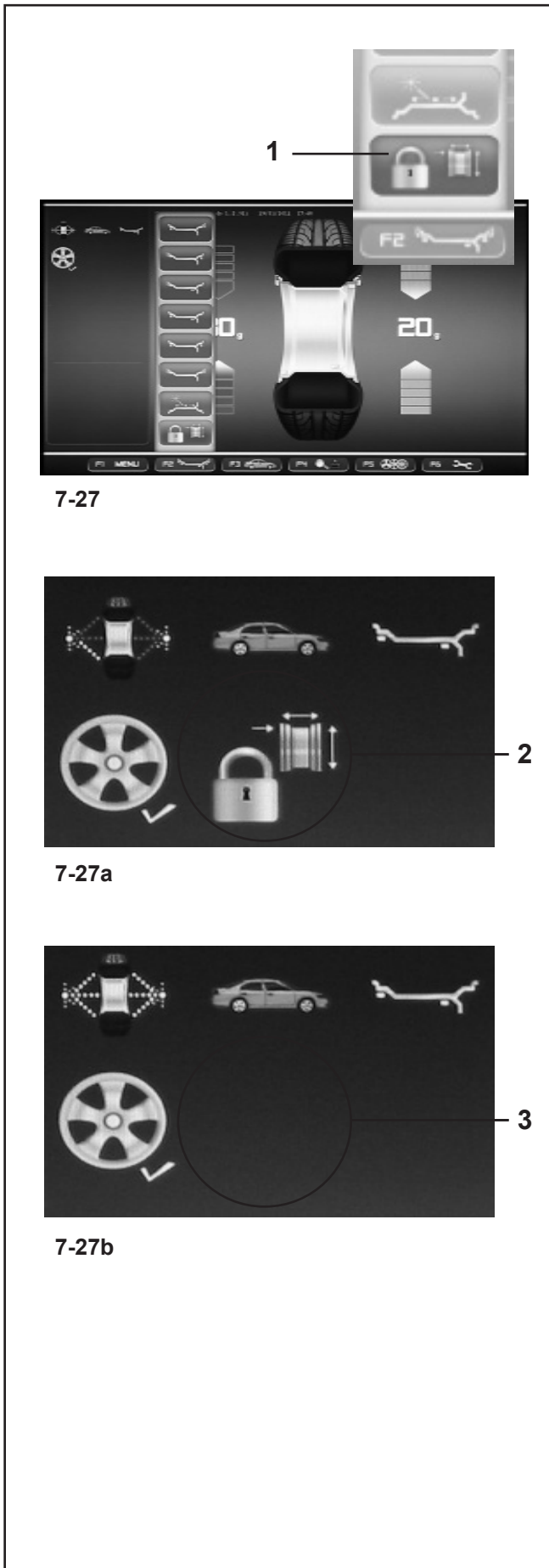

The *Rim data freeze* condition set is also identified by the icon shown on the right of the monitor, with the following meaning:
(Fig. 7-28)

a) Yellow hatching for external and internal detectors, indicating that the Wheel Data Freezing function is not activated. For every measuring run after clamping the wheel the machine will perform the complete wheel scan.

b) Grey hatching for external and internal detectors, indicating that the Wheel Data Freezing function is activated. The subsequent wheels will be balanced without the wheel profile scan and the machine will use the data previously detected and saved.

c) Grey hatching for the detector on the outside of the wheel and grey hatching with yellow only for the lower part of the detector on the inside of the wheel, indicate that the Wheel Data Freezing function is activated and the Laser Pointer mode (previously activated) is ON. The machine will not scan the wheel and will use the data previously detected and saved. The internal laser will still be available for pointing to the areas where stick-on weights must be fixed.

Special conditions of the function

Spoked rims:

To divide the weight on a set of wheels with spoked rims, in the Wheel Data Freezing function, after clamping the second wheel (the first following Freezing activation) you must:

- align one of the spokes on the 12 o'clock position and press **F5** (1, Fig. 7-29) to enter the position.

Note:

The information about the number of spokes is saved for the subsequent wheels, for which you no longer need to enter the data item, whilst the 12 o'clock position must be set again for each wheel.

Manually changing a wheel data item:

If you change a data item in the RIM DATA INPUT screen page, after selecting Wheel Data Freezing, the freezing setting will be cancelled automatically and the machine will proceed in MANUAL mode, considering the data just entered. When the next wheel is clamped on the balancer, the machine will perform the complete scan of the profiles.

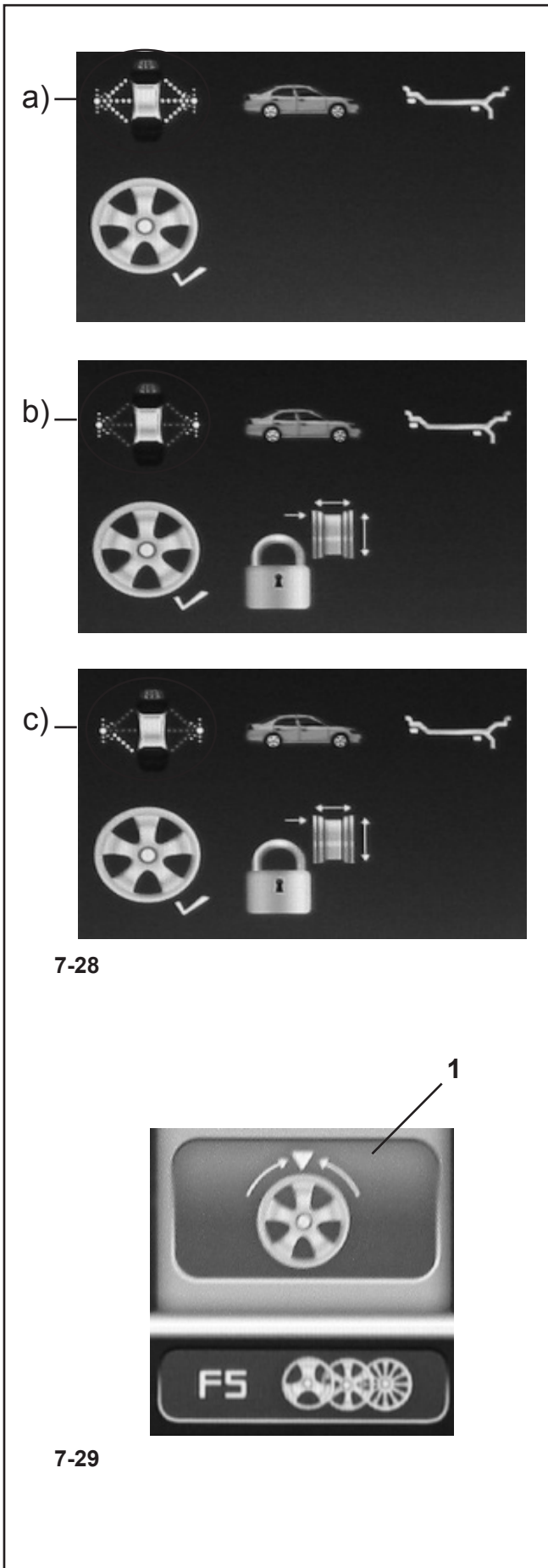

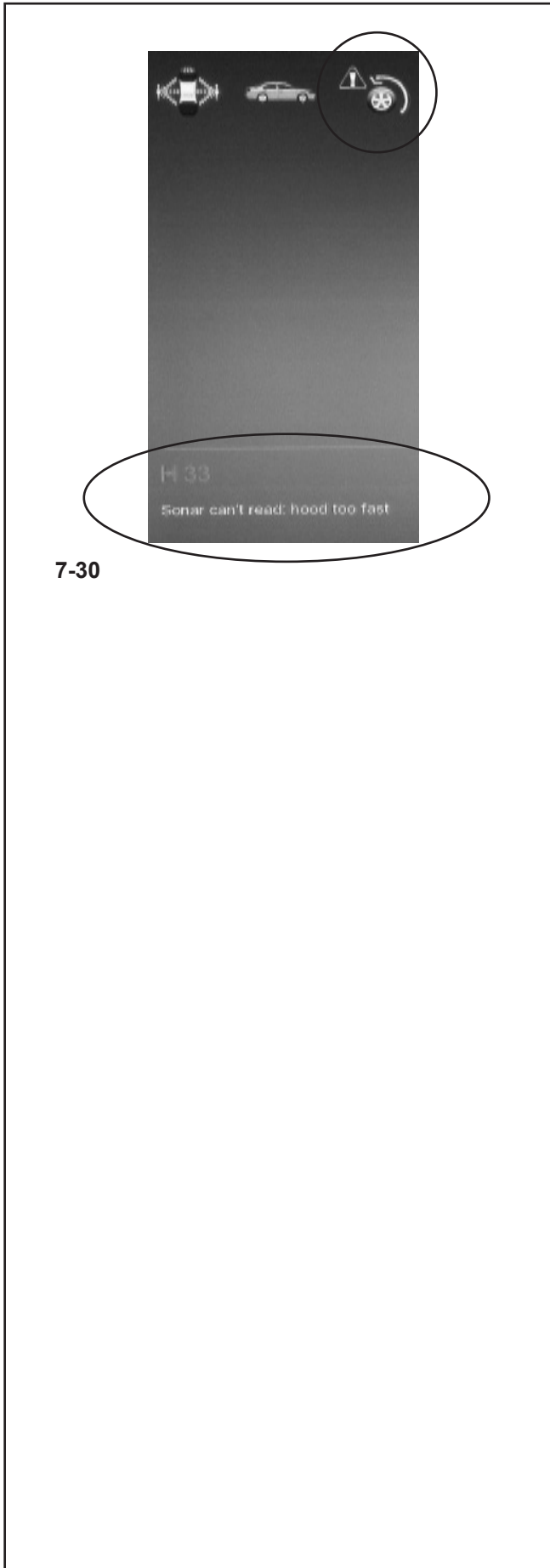

7-30

7.8.2 Wheel measuring run (PROFILING mode)

- Lower the wheel guard from the fully raised position. Pull the guard smoothly at medium speed, without stops or jerking even to the side.

Note:

You must be very careful when lowering the guard, as the machine simultaneously scans the wheel external rim profile.

If you lower the wheel guard incorrectly:

the machine immediately indicates the incorrect maneuver, showing a specific warning icon on the screen. See Fig. 7-30.

The message is cleared

- automatically after a few seconds
- when you reopen the wheel guard
- when you press the STOP key or the ESC key

If you decide not to repeat wheel guard lowering, you can press START to continue with the measuring run.

In this way the wheel width is not automatically detected by the sensor and the machine uses the last value saved. To check the width present press **F1** and select RIM DATA INPUT.

The width value is shown in red, indicating that it was not detected automatically.

If necessary you can set the width manually before proceeding. If you enter the value manually the machine will supply the balancing data correctly but some recalculation functions will not be possible.

If you lower the wheel guard correctly:

- With the **PROFILING MEASURING RUN NOT ACTIVATED**,

no signal appears on the screen, therefore to proceed with the run

- press the START button.

The balancer performs the measuring run with the unbalance measuring cycle and rim profile detection (to find the type, steel/aluminium and count the spokes, if present).

At the end of the run, the unbalance values and the points where the balancing weights should be applied are displayed.

Press **F1** and select RIM DATA INPUT. to check the rim nominal dimensions.

Press **F2** to alternate the type of ALU by selecting it from those suggested. The Menu contains only the ALU that the machine retains possible, based on the

type of rim detected. At every ALU change the balancer automatically recalculates the value and position of the weights.

The wheel measuring run may have detected the number of spokes: in this case press **F5** to activate the hidden weight mode.

- With **PROFILING MEASURING RUN ACTIVATED**,

the machine proceeds directly to the measuring run.

At the end of the run, the unbalance values and the points where the balancing weights should be applied are displayed.

Only if it is impossible to read the wheel width (e.g.: rim without a tire) the wheel data input screen page appears automatically, with the values not detected shown in red.



7-31

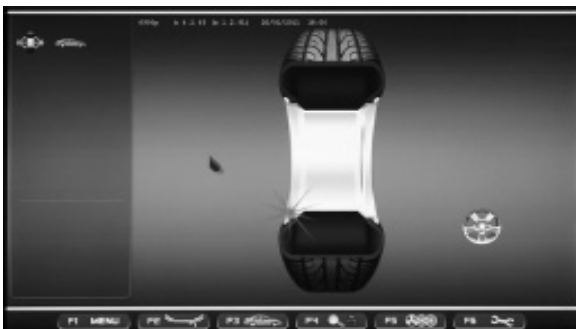

7-32

7.9.2 Advanced Spoke Detection

This mode, which can be activated when required, allows absolute precision when detecting the position and dimensions of the rim spokes, to allow more precise behind the spokes placement. By the laser scanners can't recognise the spokes or the operator decides he is dealing with a rim with a particularly complex shape, enable the Advanced Spoke Detection function which recognizes any type of spokes, even those with unusual shapes, for example: paired, oblique, with holes or of different sizes to one another (fig. 7-31).

Before performing the measuring run:

- From the FUNCTION screen select "Enabled" next to the "Advanced Spoke Detection" item.
- Perform the normal procedures for the run.

Note: This function increases the time for the total measuring cycle by 5 seconds

When the Spokes Advanced Gauge is active, the screen shown in the fig. (2, Fig. 7-32) is displayed.

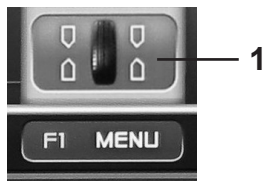

8-1



8-2

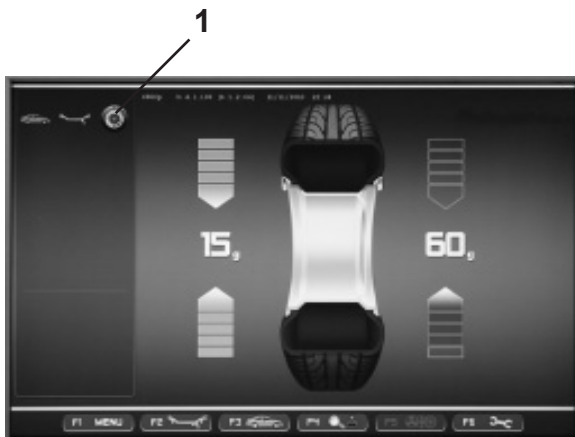

8-3

8. Balancing

Preliminary operations:

- If necessary, perform a compensation run (Section 6.4).
- Check the wheel is clamped correctly (Section 6.5).
- Select the Type of Vehicle (Section 7.1.1).
- Read the rim dimension parameters (Chapter 7.2).

If more than one wheel of the same type needs to be balanced (the same nominal dimensions) the data need only be set for the first wheel. The selections stay set until other new data is set or the machine is switched off.

To access the BALANCING screen:

- Press the **F1** Menu Key and select the Balancing item (**1**, Fig. 8-1).

The BALANCING screen (**Figure 8.2**) will open.

Fig. 8-2 BALANCING

Menu key details:

F1 Contains the different screen access options.

F2 Contains the ALU Type selection options.

F3 Contains the Type of Vehicle selection options.

F4 Contains the setting options for:

Static Imbalance

End of weight reading

Grams / Ounces

Weight Miser (if included)

F5 Not active

F6 Contains the COMPENSATION RUN option.

8.1 Measuring imbalance

Having completed the preliminary operations, a Measuring run can be launched:

- Close the wheel guard and press the **START** key.

The BALANCING screen appears (**Fig. 8-3**).

After measurement the balance weights can be fitted, or a weight minimization or optimization run can be carried out. The specific icon (**1**, Fig. 8-3), indicates that the machine suggests a weight Optimization or Minimization procedure is carried out.

After measurement the machine stops automatically and the wheel is braked such that the weight for the left (Factory selection) correction plane can be fitted exactly perpendicular to and above the main shaft. The screen shows the unbalance measured for each correction plane and the direction towards correction.

Balancing position and weight gauges:

The arrows shown in the BALANCING screen, at the end of the launch, help reach the compensation weight application position rapidly. The operator should turn the wheel to obtain quantity and direction indications from the colour and movement of the arrows, as follows:

Figure 8-4 (here: vehicle wheel, normal weight position):

- Left rotation indicator: both the arrows are green, the left side is in the compensation position.
- Right rotation indicator: the lower arrow is red and indicates the rotation direction to reach the compensation position.

Figure 8-4 Color specifications

- 1 No colour: greater distance from position
- 2 Red: rotation direction to reach the position, the higher the number of lit segments the more the wheel must be rotated.
- 3 Green: compensation position reached, hold the wheel in this position to apply the weight.

Fig. 8-5 Example of display and correction of the lefthand correction plane.

- 1 Correction weight on rim application position (on the wheel axis)
- 2 Display of amount of unbalance
- 3 Display of correction position - the two arrows light up.

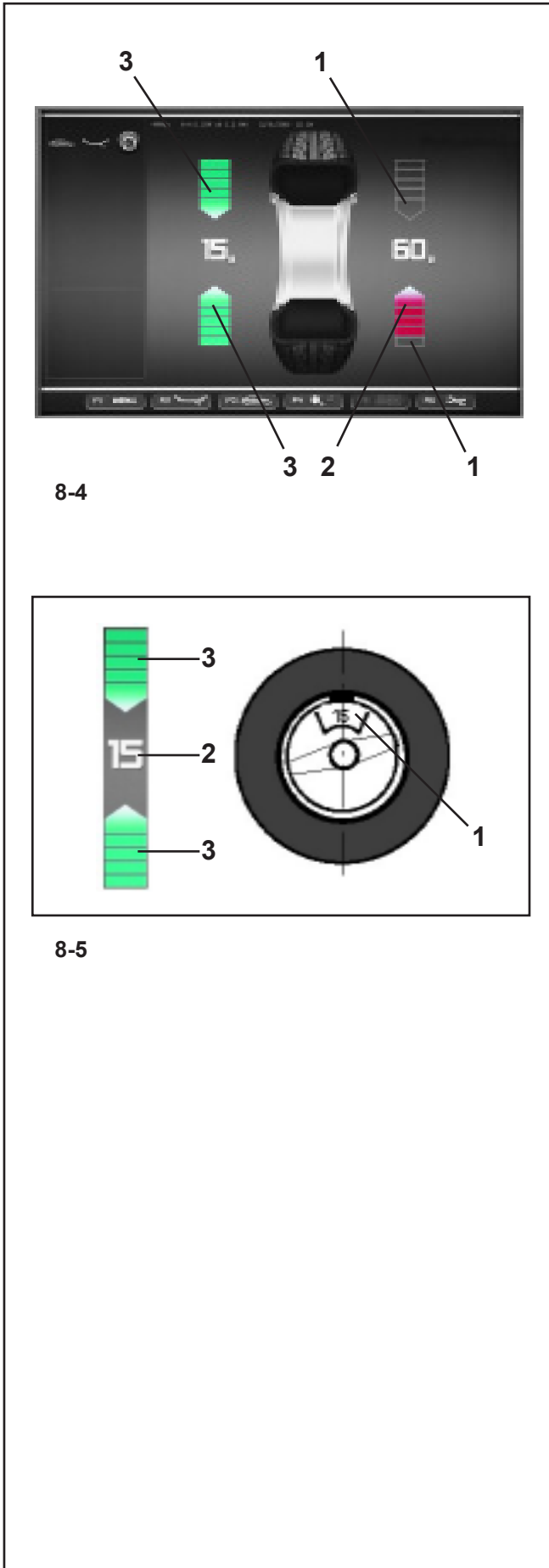



8-15

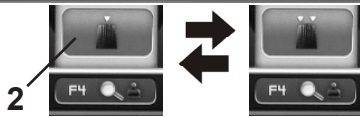

8-16

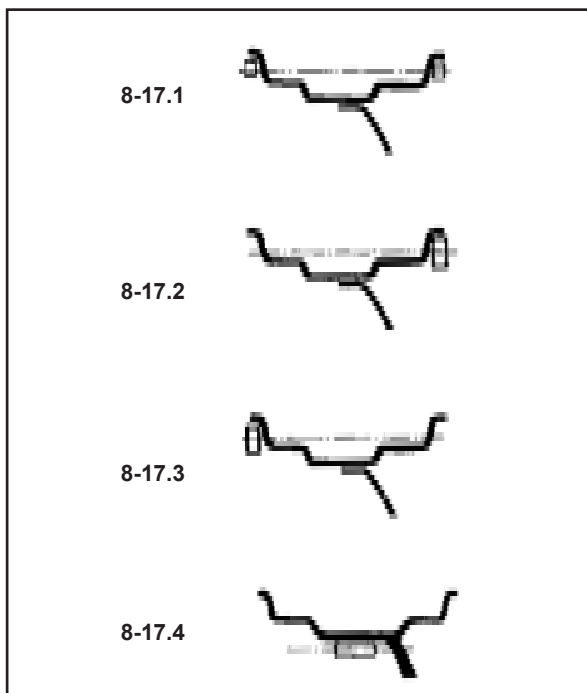
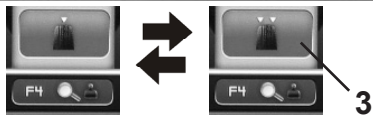

8-17

8.1.1 Static unbalance

In general the wheels should be balanced dynamically, i.e. in two correction planes.

If the wheels to be balanced are rather small (e. g. motorcycle wheels), only static unbalance should be measured and corrected.

- For the static imbalance indication press the **F4** menu key and then select Static (**2, Figure 8-15**).

A screen as in **Fig. 8-16** comes up.

For correction diameter and possibilities of correction of static unbalance see **Fig. 8-17**.

Recommendations for fitting balance weights for static unbalance correction

The correction diameter for static unbalance correction is programmed as follows:

nor. same as for correction of dynamic unbalance

Alu 1 same as for correction of dynamic unbalance

Alu 2 in the rim disc (drop-centre)

Alu 3 in the rim disc (drop-centre)

Alu 4 at rim flange

Alu 5 at rim flange

As it is not always possible to correct static unbalance in the ideal rim position, the following recommendations for correction (**Fig. 8-17**) should be observed.

Balance clips (Alu 0 , Alu 4 and Alu 5)

- With large static unbalance (e. g. 30 g) divide the unbalance into two fairly equal parts and correct it at both sides of the wheel, considering the chosen balancing mode (**Fig. 8-17.1**).
- With small static unbalance fit the balance weight either in the outer or inner correction plane (**Fig. 8-17.2 and 8-17.3**).

The dynamic unbalance created thereby is negligible.

Note:

Figures **8-17.1–8-17.3** illustrate how balance clips can be fitted. When adhesive weights are used, or both types are mixed, proceed analogously depending on balancing mode.

- For balancing modes Alu 2 and Alu 3 fit a balance weight in hidden position inside the rim; in this case the correction diameter for static unbalance correction lies inside the rim (**Fig. 8-17.4**).

To display the dynamic imbalance again.

- Press **F4** and select Dynamic (**3, Figure 8-16**).

8.2 Applying Balancing Weights

Fitting of balancing weights for the balancing modes is specified and illustrated in this paragraph.

8.2.1 How to fit balance clips

Left correction plane:

After the measuring run.

- If necessary, index the wheel precisely into the correction position for the left plane. When the correction position is reached, the two arrows (3, Fig. 8-6) light up green.
- Press the pedal of the main shaft lock to hold the wheel in this position.
- Apply the clip on weight to the rim flange, in the compensation position exactly perpendicular to and above the wheel holder shaft (Figure 8-6).

Right-hand correction plane:

- If necessary, turn the wheel again to move it into the right correction plane compensation position.
- Press the pedal of the main shaft lock to hold the wheel in this position.
- Apply the clip-on weight to the rim flange in the correction position exactly perpendicular to and above the wheel holder shaft (Figure 8-6 and 8-7).

After correction carry out a check run (see § 8.3).

Note:

After balancing perform a Test Run (see Chapter 8.3).

8.2.2 How to fit adhesive weights based on given dimensions

If the correction positions are not accessible with the gauge arm and the wheel dimensions have been entered using the function keys:

- Fit adhesive weights in the given positions according to the balancing mode. Make sure to observe the given positioning dimensions (Fig. 8-8).

Dimensional tolerances result in slight deviations of the measured values so that the weight may need to be repositioned after the check run. In this case an OK indication is not displayed after the check run (Fig. 8-9).

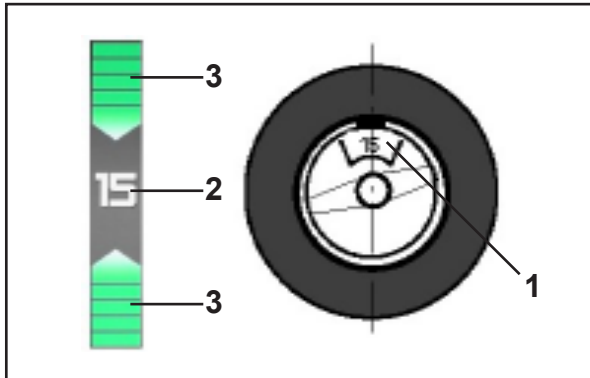

8-6

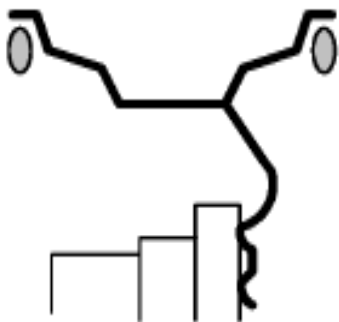

8-7



8-8



8-9

8.2.3 Using the Laser Pointer

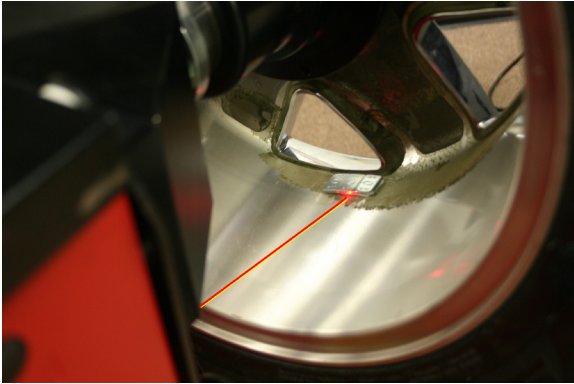

8-10

In Alu 2P and Alu 3P modes the correction planes for adhesive weights are precisely indicated by the laser pointer directly on the rim.

Note:

When the indication is given by the laser, the weight must not be fitted at 12 o'clock, but at the bottom of the rim, precisely where indicated by the pointer (**Fig. 8-10**).

There are at least two positions where the adhesive weights can be fitted, indicated by the Laser pointer, depending on the wheel type and the balancing mode.

When a run is completed correctly the BALANCING screen shows the correction values and the position where the weights must be fitted.

To make the corrections,

- Select an adhesive weight of the indicated size and adjust it to the wheel radius by bending.
- If necessary, index the wheel precisely into the correction position for the left plane. When the correction position is reached, the two arrows on the screen light up green.
- Press the pedal of the main shaft lock to hold the wheel in this position.
- Clean the fitting position before attaching the adhesive weights.
- Fit the balancing weight and firmly press the adhesive weight onto the rim.
- Fit the second adhesive weight in the same manner.

The position for fitting the weights indicated by the Laser pointer can be varied for each correction plane.

- See "RELOCATION" (section 7.8).

8.3 Test Run

- After applying the balance weights perform a Test Run.

Having finished the Test Run, if the wheel is balanced correctly, both the numerical indicators should indicate 0 and an OK should be displayed (**Fig. 8-11**).

Note:

If there is no OK reading, dynamic unbalances below the tolerance limit (suppression preset to 3.5 g) add to a static unbalance above the tolerance limit. Press the end indication key in Menu **F4 (1, Figure 8-11)** and the residual imbalance values will appear for several seconds and then they can be eliminated.

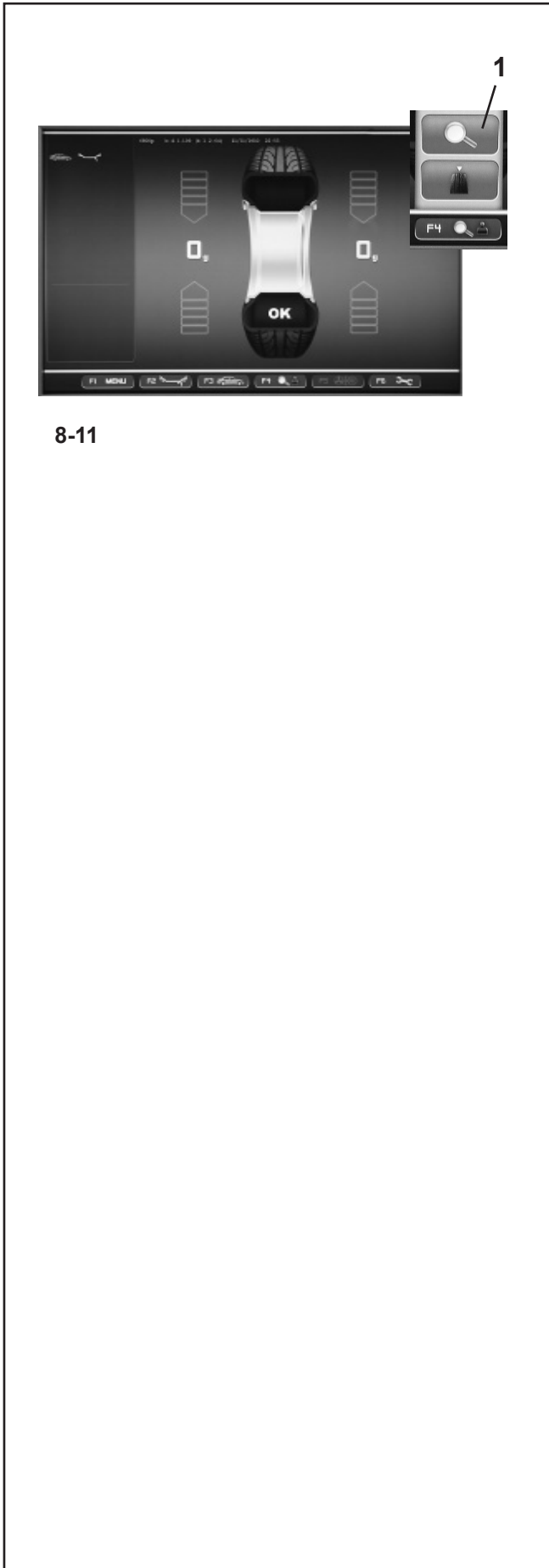

8-11

8.4 Behind-the-spokes placement

When spoked wheels are balanced, the behind-the-spokes placement mode (also called split weight mode) allows balance weights which would have to be fitted between two spokes according to the measured unbalance (hence would be visible from outside) to be placed in hidden position behind two spokes adjacent to the unbalance location (see example, **Fig. 9-1**).

After a measuring run the electronic unit calculates the behind-the-spokes placement automatically and reads the relative balance weight locations on the screen.

The operating steps for the behind-the-spokes placement mode are described and illustrated below.

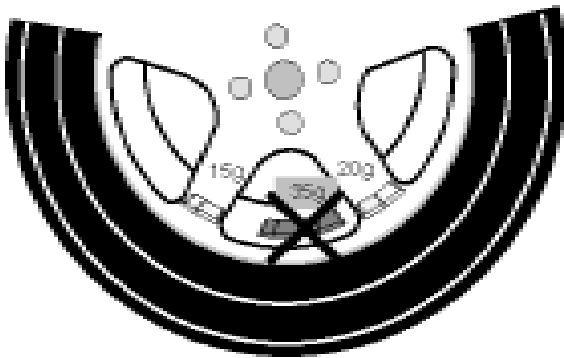

9-1

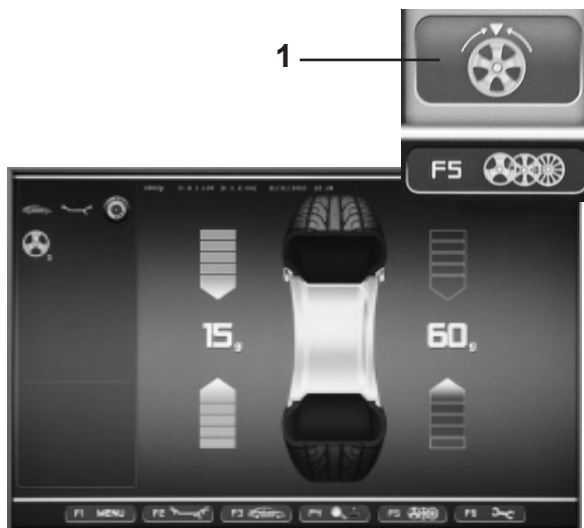

9-2

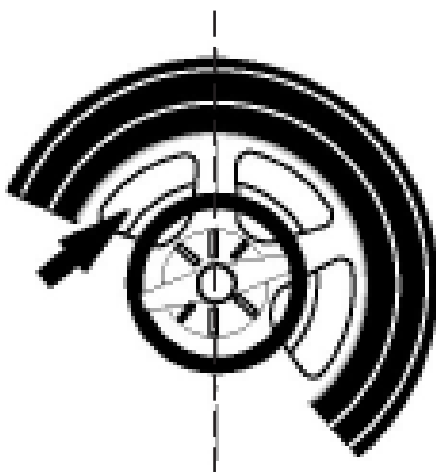

9-3

8.4.1 Selecting the Hidden Weight Mode

The behind-the-spokes placement mode is activated with the menu key **F5** in the screen **BALANCING**.

Weights can be positioned behind the spokes in the Alu 2, Alu 2P, Alu 3 and Alu 3P (hidden compensation weight) balancing modes and can be selected in these spheres as required.

Note:

The "Hidden Weight" selection key is only active after the number of spokes have been entered using the **F5** menu key.

How to proceed

After this run, in the **BALANCING** screen:

- Use the **F5** menu to select the number of spokes in the wheel on the machine (if not already entered) (**Fig. 9-4**).

The Status Bar field displays the indication: number of spokes set.

The number of spokes can vary from 3 to 15.

- Rotate the wheel so that a spoke is centred relative to and above the main shaft (**Fig. 9-3, arrow**).

Note:

We suggest you keep the wheel in position with the brake pedal until the selection has been made.

- Use the **F5** menu key to select the Hidden Weight behind spokes item (**1, Fig. 9-2**).

The function is now selected and on the right of the screen two balancing gauges are shown instead of one.

Behind-the-spokes placement

- Proceed, if necessary, with Optimization/Minimization, or apply the compensation weights directly (Chapter 9.3).

To exit the Hidden Weight mode and display the normal indication of imbalances (**Fig. 9-2**) proceed in the same way:

- Use the **F5** menu to select the Hidden Weight item (**1, Fig. 9-4**). The imbalances for the left and right compensation planes are displayed.

In this way wheels without spokes can be balanced even when you are working with a program for weights behind the spokes without having to change the Alu program for a different weight placement.

In any case, as long as an Alu 2, Alu 2P, Alu 3 or Alu 3P are set, weight placement behind the spokes can be activated at any time.

Exiting the BALANCING screen does not exit the Hidden Weight function.

Note:

The unbalance reading is only subdivided on two fitting positions when the spoke position is stored (**Fig. 9-5**).

When balancing with counterweights positioned behind the spokes if you also need to perform an Optimisation/Minimisation run, do it before applying the weights.

After running an Optimisation/Minimisation procedure by selecting the weights positioned behind the spokes mode, the imbalance indicated is automatically split into two application points behind the spokes.

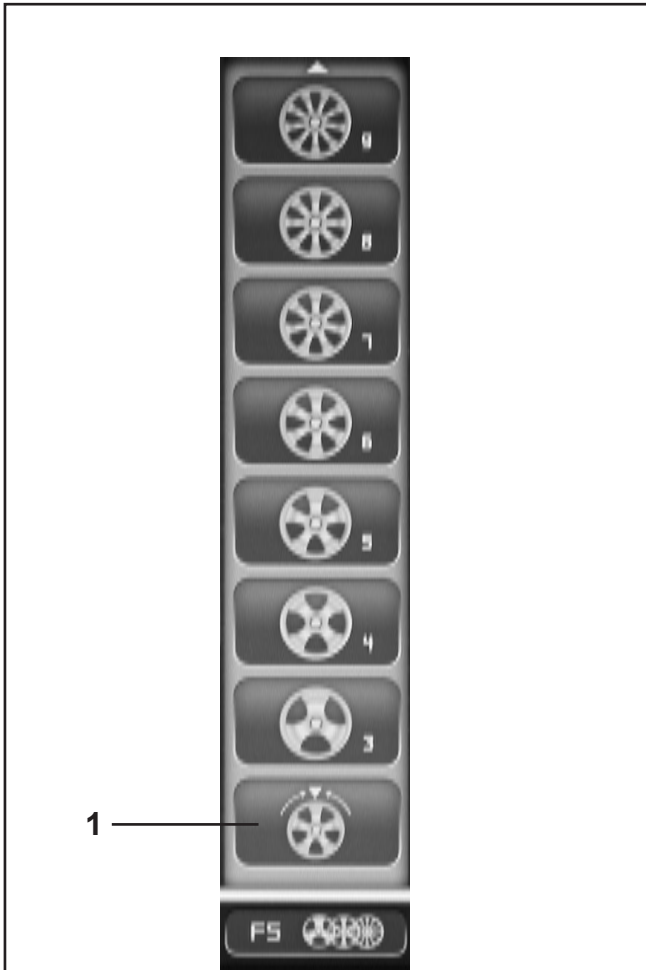

9-4



9-5

Behind-the-spokes placement

8.4.2 Hidden weights placement

How to fit adhesive weights on the left side of the rim disc

- Clean the fitting position before attaching the adhesive weights.
- Fit adhesive weights on the left side of the rim disc as described in § 8.2.2.

Applying hidden adhesive weights

The measured values and the positioning arrows for the two correction positions behind the spokes (**Figure 9-6**) are given on the right of the Indications Field.

- Turn the wheel to move one of the split imbalances, on the right side (**A, Figure 9-7**) into the compensation position (green arrows), then lock the wheel with the brake pedal.
- Clean the application point before attaching the adhesive weight.
- Apply the balance weight (in the example 55 grams, **A, Figure 9-7**) at the point indicated.
- Turn the wheel to reach the remaining split right side weights compensation position, then lock the wheel with the brake pedal.
- Having cleaned the area affected, apply behind the second spoke the weight of the value indicated (in the example 75 grams, **B, Figure 9-7**).

Note:

Applying split weights does not involve priorities. The operator can choose which to apply first.

In Alu 2S and Alu 3S modes the correction planes for adhesive weights are precisely indicated by the laser pointer directly on the rim.

Note:

When the indication is given by the laser, the weight must not be fitted at 12 o'clock, but at the bottom of the rim, precisely where indicated by the pointer (Chapter 8.2.4).



9-6

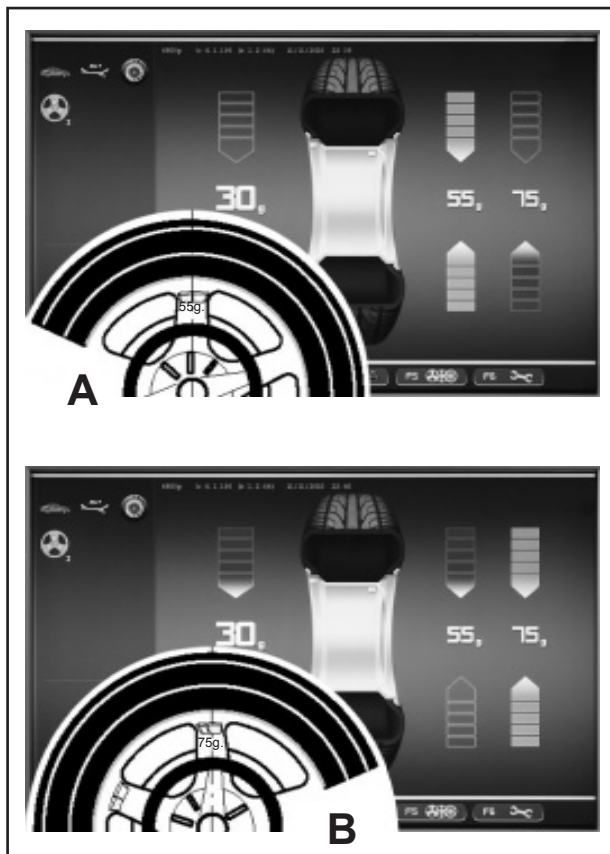

9-7

9. Optimization / Minimization

9.1 General

Optimization is a finer form of matching.

During the opto-ride procedures the rim and Tire are adjusted relative to each other on the basis of different unbalance measurements. This generally means that, where present, lateral and radial run-out and radial and lateral force variations are reduced and thus wheel running conditions optimised. In addition, the mass (balance weight) necessary for balancing can be reduced.

If Optimization is not desired, it is possible to achieve weight Minimization (so-called matching).

This is e. g. possible if the rim does not exhibit geometric deformations, in other words when unsmooth wheel running conditions are a result of a non-uniform Tire.

In this case the unbalance of the rim can be readjusted relative to the unbalance of the Tire such that the unbalances compensate each other and the smallest possible weight for unbalance correction is determined.

9.2 Instructions for the Optimization / weight Minimization programs

When balancing a wheel, by pressing this key (1, Fig. 9-1) you can recall the Optimization and/or Minimization cycle screen (Fig. 9-2).

Using the F4 Menu (Fig. 9-2), you can select the item for starting the Optimization (1, Fig. 9-2) or Minimization (2, Fig. 9-2) cycle.

After being started, the cycle can be suspended at any time, for example, to allow a second operator to balance another wheel. The point at which the program was interrupted, the dimensions of the previous rim and all the measurements taken on it will be saved in the electronic control unit memory. So to continue from the exact point you were at, all you need to do is refit the wheel that has been interrupted and recall the suspended programme.

From the screen (Fig. 9-3):

Recall the suspended cycle by pressing F3 (1, Fig. 9-3).

Use F4 (2, Fig. 9-3) to start a new Optimization / Minimization cycle; the data saved in the memory will be deleted.

During an Optimization /Minimization cycle, if a run is interrupted because the STOP key is pressed (e.g. because of an emergency), the machine retains the program position while waiting for the run to be repeated.

A measuring run must always be launched using the START key.

During the Optimization /Minimization cycle, even if the operator has previously set a compensation on the locking tool, it is not activated.

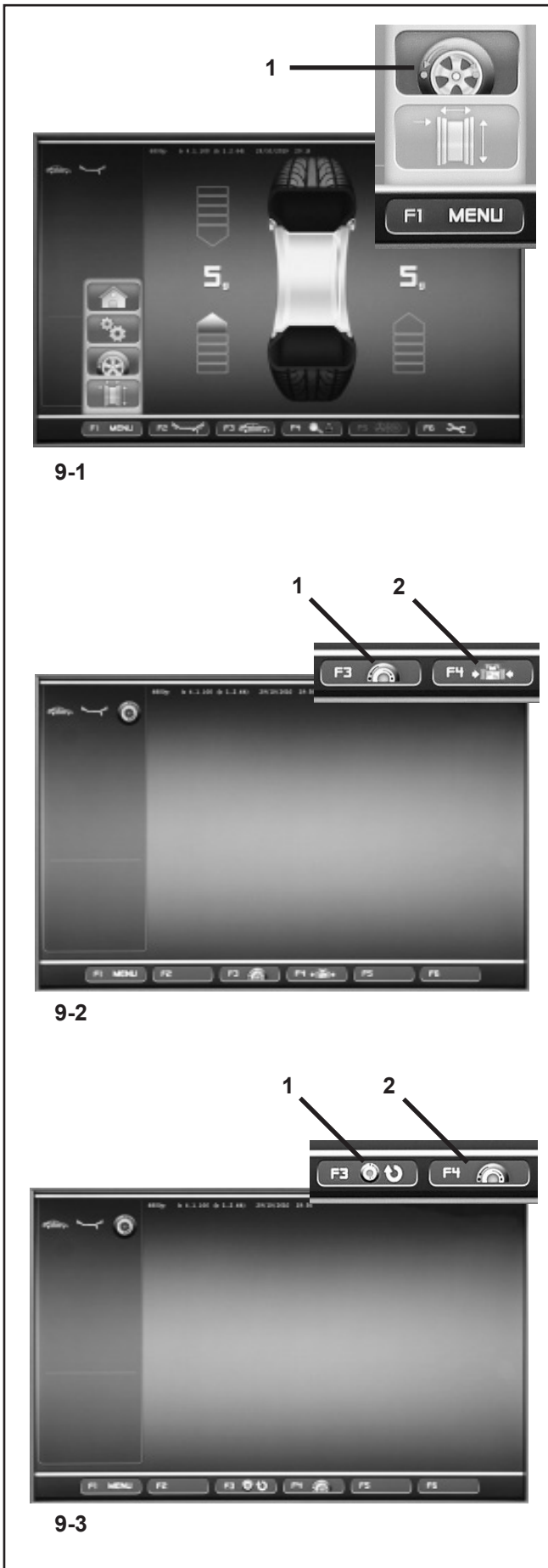



9-2a



9-4



9-2b



9-5

9.3 Start Optimization /weight minimisation

- To perform a Minimization run correctly clamp a complete wheel (Section 6.5) or just the rim for an Optimization run.
 - For a Minimization run, check that the Tire is correctly mounted on the rim (Axial run-out test) and that it is pumped up to the set pressure.
- Select the Vehicle Type (Section 7.1.1).
- Read the rim dimension parameters (Chapter 7).
- Launch a Measuring run.
- On the BALANCING screen press the **F1** Menu key, and then select the Optimization item (**1**, Fig. 9-1).

The Optimization screen (Fig. 9-2) is displayed.

You can now start the procedure as follows.

Start weight Optimization

- Press the **F4** Menu key and then select the Start Optimization item (**1**, Fig. 9-2a).

The OPTIMISATION 1 screen (Fig. 9-4) is displayed.

Continue as described in Chapter 9.3.2.

Start weight minimisation

- Press the **F4** Menu key and then select the Start Minimization item (**1**, Fig. 9-2b).

The Minimization 1 screen (Fig. 9-5) is displayed.

- Proceed from the Minimization 1 item as described in Chapter 9.3.1.

Recalling Optimization / Minimisation

Note:

If a previously interrupted Optimization /Minimization run is in the memory, when the Optimization item is selected from the F1 Menu, the Optimization screen (Fig. 9-4) is displayed. The interrupted cycle can be restarted using the **F3** Menu key. The program will proceed from exactly the point at which it was interrupted.

- Clamp the wheel removed previously when the Optimization /Minimization run was interrupted.
- Press the menu key **F3**.

The screen in which Optimization /weight Minimization was previously interrupted is displayed.

- Proceed according to the current programme stage.

9.3.1 Minimization Cycle

Fig. 9-6 Minimization 1

(First measuring run of Tire/rim assembly)

- Position the valve exactly perpendicular to and above the wheel holder shaft.
- Enter the valve position by pressing menu key **F4** (Fig. 9-6).

The Minimization 2 screen (Fig. 9-7) is displayed.



9-6



9-7

Fig. 9-7 Minimization 2

START? is signalled on the screen.

- If necessary, go back by pressing menu key **F5**.
- Close the wheel guard and press the **START** key.

A measuring run is performed.

- Next proceed as for Optimization , starting at the screen as shown in § 9.5.



9-4



9-8



9-9



9-10

9.3.2 Optimization Cycle

Having accessed the Optimization 1 screen (Figure 9-4), as indicated at the start of this chapter.

Fig. 9-4 Optimization 1

(Compensation run of rim only)

- Turn the rim until the valve is exactly perpendicular to and above the wheel holder shaft.
- Enter the valve position by pressing menu key **F4**.

The Optimization 1 screen (Fig. 9-8) is displayed.

Fig. 9-8 Optimization 2

START? is signalled on the screen.

Note:

If necessary you can turn the wheel backwards using the **F5** Menu key.

- Close the wheel guard and press **START**.

When the run finishes the Optimization 3 screen is displayed (Figure 9-9).

Fig. 9-9 Optimization 3

- Mount the Tire correctly on the rim and inflate to specified inflation pressure (make sure the mounting guide rim of the Tire is correctly seated).
- Confirm by pressing menu key **F4**.

The Optimization 4 screen (Fig. 9-10) is displayed.



9-10



9-11



9-12



9-13

Fig. 9-10 Optimization 4

(first measuring run of Tire/rim assembly)

- Clamp the wheel on the balancer.
- Position the valve exactly perpendicular to and above the wheel holder shaft.
- Enter the valve position by pressing menu key **F4**.

The Optimization 5 screen (**Fig. 9-11**) is displayed.

Fig. 9-11 Optimization 5

START? is signalled on the screen.

Note:

The **F5** key allows you to move back a step.

- Close the wheel guard and press **START**.

When the run finishes the Optimization 6 screen is displayed (**Figure 9-12**).

9.3.3 Continue Minimization And Optimization

Fig. 9-12 Optimization 6

(second measuring run of Tire/rim assembly)

From this screen weight Minimization is carried out in the same way as Optimization .

- Rotate the wheel into marking position following the arrows.
- In this position mark a **notch** the outside of the Tire at the point exactly perpendicular to and above the wheel holder shaft.

Note:

The **F5** key allows you to move back a step.

- Confirm by pressing menu key **F4**

The Optimization 7 screen (**Fig. 9-13**) is displayed.

Reading H 1

If **H1** is displayed, which is possible, continuing the Optimization run is not recommended as the measurement values that activate the invitation to perform an Optimization run are below the preset threshold limit.

In any case the cycle can be continued to obtain lower noise levels, also for values below the threshold limit (critical vehicle).

Interrupting Optimization :

- Proceeding with any other operation will interrupt the Optimization /Minimization run in progress. The function will be completely deleted from the memory only when

Optimization / Weight Minimization



9-14



9-15



9-16



9-17

a new Optimization /Minimization cycle is started, or when the machine is switched off.

Continuing Optimization :

Figure 9-13 Optimization 7

- Remove the wheel from the balancer.
- Using the Tire-changer, fit the Tire back on the rim until the notch and the valve on the rim are in line.
- Confirm by pressing menu key **F4**.

The Optimization 8 screen (**Fig. 9-14**) is displayed.

Fig. 9-14 Optimization 8

(3rd measuring run of Tire/rim assembly)

- Clamp the wheel on the balancer.
- Turn the wheel until the valve is exactly perpendicular to and above the wheel holder shaft.
- Enter the valve position by pressing menu key **F4**.

The Optimization 9 screen (**Fig. 9-15**) is displayed.

Fig. 9-15 Optimization 9

START? is signalled on the screen.

Note:

The **F5** key allows you to move back a step.

- Close the wheel guard and press **START**.

When the run terminates either the screen Optimization 10, outside (**Fig. 9-16**) or the screen Optimization 10, inside (**Fig. 9-17**) is displayed. In this case the operator has to choose how to continue by choosing from the **F4** Menu key options (**1/2, Figure 9-17a**)

Reading H 0

Optimum condition has been achieved and cannot be improved.

- Continue as shown on screen Optimization 14 (**Fig. 9-22**).

Reading H 2

Wheel running conditions cannot be improved. However, it is possible to readjust the Tire relative to the rim to obtain a quite considerable Minimization of balance weights (i.e. smaller weights) without having an adverse effect on wheel running conditions.

- Continue as shown on screen Optimization 10 (**Fig. 9-16**).



9-16



9-17a

1

2



9-18



9-19

Fig. 9-16 Optimization 10, outside

- Rotate the wheel into marking position following the arrows.
- In this position **mark a double notch** on the **outside** of the Tire exactly on the wheel holder shaft.

Note

The **F5** key allows you to move back a step.

- Confirm by pressing menu key **F4**.

The Optimization 11 screen (**Fig. 9-18**) is displayed.

Fig. 9-17 Optimization 10, inside

Option 1: TIRE NOT TURNED OVER

If the Tire must not be turned over on the rim:

- Press the **F4** Menu key to select the “**NOT TURNED OVER**” item (**1, Fig. 9-17a**); the machine will re-propose “Optimization 10, external” (**Fig. 9-16**) and the operator can continue following the indications in the previous step.

Option 2: TIRE TURNED OVER

If the Tire is turned over on the rim:

- Press the **F4** Menu key to select the “**CONFIRM**” item (**2, Fig. 9-17a**) and continue as follows.
- Turn the wheel to the position marked by the notch (green direction arrows)
- In this position **mark a double notch** on the **inside** of the Tire exactly perpendicular to the wheel holder shaft.

Note:

The **F5** key allows you to move back a step.

- Confirm by pressing menu key **F4**.

The Optimization 11, turn screen (**Fig. 9-19**) is displayed.

Fig. 9-18 Optimization 11

- Using the Tire-changer, push the Tire along the rim until the double notch and the valve on the rim are in line with the valve.
- Confirm by pressing menu key **F4**.

The Optimization 12 screen (**Fig. 9-20**) is displayed.



9-19



9-20



9-21



9-22

Fig. 9-19 Optimization 11, turn

- Remove the wheel from the balancer.
- Using the Tire-changer, turn the Tire over on the rim.
- Push the Tire along the rim until the double notch and the valve on the rim are in line with the valve.
- Confirm by pressing menu key **F6**.

The Optimization 12 screen (**Fig. 9-20**) is displayed.

Fig. 9-20 Optimization 12

(4th measuring run of Tire/rim assembly)

- Clamp the wheel on the balancer.
- Position the valve so it is exactly perpendicular to the wheel holder shaft.
- Confirm the valve position by pressing menu key **F6**.

The Optimization 13 screen (**Fig. 9-21**) is displayed.

Fig. 9-21 Optimization 13

START? is displayed on the screen.

Note:

The **F5** key allows you to move back a step.

- Close the wheel guard and press **START**.

A measuring run is performed.

The Optimization 14 screen (**Fig. 9-22**) is displayed.

9.3.4 Finish weight Minimization / Optimization

Fig. 9-22 Optimization 14

If the wheel running conditions are optimal, the following codes can be displayed:

- H0** Wheel running conditions cannot be improved by Optimization .
- H1** Further Optimization not recommended but feasible.
- H2** Weight Minimization is recommended, Optimization can achieve no further improvement.

If Optimization has been performed:

The pictograph OK shows that Optimization was carried out correctly and has been completed successfully.

If Minimization has been performed:

The pictograph OK shows that Minimization was carried out correctly and has been completed successfully.

To return to the BALANCING screen:

- Press the **F1** Menu key and select the BALANCING item (**Figure 9-23**).



9-22



9-23

10. Operating Mode - Selecting and Setting Parameters

Normal operation usually does not require any modification of the factory-adjusted modes of operation or their factory-adjusted state.

Variations, however, can be made by selecting certain specific items in the SETTINGS screen. In addition to the changes made to the functioning modes, from this menu various counters can be displayed showing the operations carried out over time by the balancer.

Recalling the SETTINGS screen

- Press the **F1** Menu key on the main menu (**Fig. 10-1**) and select the SETTINGS item (**1, Fig. 10-1**).

The SETTINGS screen **Figure 10-2** will open and the Basic List panel will be immediately active (**1, Fig. 10-2**), (CATEGORIES).

The various items can be selected using the **SCROLL** command and then by confirming with **OK**.

An active panel presents an illuminated image of the flange.

When an item is selected the panel that contains it turns a darker colour.

CATEGORIES (1, Figure 10-2)

- Using the **SCROLL** command select a Category:
 - **General settings**
 - **Setting Measurements**
 - **Network and Printer connections**
 - **Counters**
 - **System information**
- Confirm by pressing the **OK** key.

This takes you to the central PARAMETERS panel (**2, Fig. 10-2**).

PARAMETERS (2, Figure 10-2)

- Use **SCROLL** to select a parameter.
- Confirm by pressing the **OK** key.

The selector shifts to the VALUES panel (**3, Fig. 10-2**) so that changes can be made or information acquired.

VALUES (3, Figure 10-2)

- Select the desired item and confirm the change following the procedure explained previously (**SCROLL + OK**).

Note:

Values cannot be changed in the Counters or Information categories.

The **F3** key activates alternately the CATEGORIES and the PARAMETERS panel.

- Press the **F1** key to return to the INTRODUCTION screen and select the relative item (**1, Fig. 10-2a**).



10-1



10-2

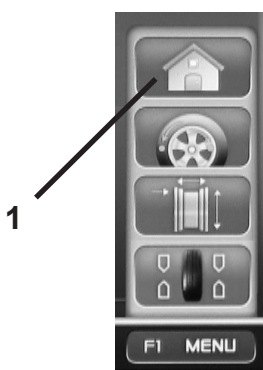

10-2a

Setting Parameters

Saving Changed Parameters

Changes to operating modes can be saved permanently using the "Saving operating modes in the permanent memory" function so they are retained every time the machine is started up.

Operating modes that are changed but not saved are reset to the pre-change value after the machine has been switched off.

The possible changes of modes and the necessary inputs are described in the following.

Saving modes of operation in permanent memory

NO* = No storage

Active = Fixes the data in the permanent memory

Store in the permanent memory – a three-tone signal is given to acknowledge acceptance.

If the mode stored in the permanent memory is to be changed, enter the desired state (e. g. on or off) for the mode in question and transfer it into the permanent memory.

10.1 List of modes of operation

Setting modes of operation as recommended

See § 5. Switching on the machine.

0* = No action

1 = Factory-adjusted modes of operations are set.

The selected mode of operation can be transferred to the permanent memory.

Language selection

Selecting the menu language. A number of languages are available, such as: English, German, Italian, French, Spanish, Portuguese.

Volume of the audible signals

Scale of volume 0 to 100 (low - high).

Factory-adjusted to 50.*

The volume is not changed before the OK o F5 key is pressed for quitting the mode.

The selected mode of operation can be transferred to the permanent memory.

Setting Parameters

Resolution of the unbalance amount readings

Selecting the resolution of unbalance readings in 1 or 5 g, or 0.05 or 0.25 oz increments.

Normal* = 5 g (0.25 oz) increments

Fine = 1 g (0.05 oz) increments

The selected mode of operation can be transferred to the permanent memory.

Suppression of minor unbalance amount readings

Off = Suppression off

On * = Suppression on

The selected mode of operation can be transferred to the permanent memory.

Setting threshold value for unbalance suppression in g

Selecting the limit (threshold) value for suppression of minor unbalance readings in grammes, or ounces. The unit (gms or oz) depends on the settings made under "Measurement limit of the unbalance amount readings".

Grammes:

Range 3.50 to 20.0 g

Factory-adjusted to 3.5 g

Ounces:

Range 0.25 to 2.00 oz

Factory-adjusted to 0.25 oz

The selected mode of operation can be transferred to the permanent memory.

Measurement limit of the unbalance amount readings

Selecting unbalance readings in grammes or ounces, active when the machine is switched on.

Gramm * = Readings in grammes

Ounze = Readings in ounces

The selected mode of operation can be transferred to the permanent memory.

Number of turns

5 to 25 revolutions possible.

Factory-adjusted to 10.*

The selected mode of operation can be transferred to the permanent memory.

Note

Reducing the number of measurement revolutions will reduce the accuracy of measurement.

Setting Parameters

Starting the measuring run by closing the wheel guard

Off* = Start via START key

On = Start via wheel guard

The selected mode of operation can be transferred to the permanent memory.

Automatic braking when the wheel guard is raised

Off = No braking

When the guard is lifted, the wheel is not braked and continues to rotate from inertia. Make sure that the wheel is not blocked by a tool or similar item. Wear safety goggles and tightly fitting working clothes.

On* = Braking

The selected mode of operation can be transferred to the permanent memory.

Adjusting the DATE/TIME COUNTERS

The flashing cursor in the Values panel identifies the character that can be changed at that moment using the **SCROLL** command.

You can move backwards and forwards in the date and time fields using the **F2 & F3** commands.

Date: Day

Actual date: selection of the day.

Date: Month

Actual date: selection of the month.

Date: Year

Actual date: selection of the year.

Time: Hour

Actual time: selection of the hour.

Time: Minute

Actual time: selection of the minute.

Note

Changes to the date and time are immediately active and are retained when the machine is next started without needing to be saved to the permanent memory.

* = Factory adjusted mode

Setting Parameters

10.2 Counters

Every measuring run actually completed is stored. Maximum count is 999,999 runs. Once this number is reached, the counter is reset to zero. The information is primarily useful for statistical purposes, e. g. to obtain evidence of load intervals of parts when defective, or of monthly (yearly) use of the machine, etc. The measuring runs performed while the machine is on are transferred into the permanent memory and added when it is switched off. The counter cannot be reset or changed.

- Select the “Counters” category (1, Fig.10-3) in the SETTINGS screen (Figure 10-2). The data immediately available in the Values field are the following:

List of Counters (Figure 10-3)

- a Total spins = Total number of measuring runs
- b Spins with o.k. = Number of measuring runs where balance quality was considered OK
- c Optimisation = Number of optimisations or minimisations
- d Service = Number of measuring runs in service mode
- e Since last calibration = Number of measuring runs since the last calibration
- f Clamps = Total number of wheels clamped

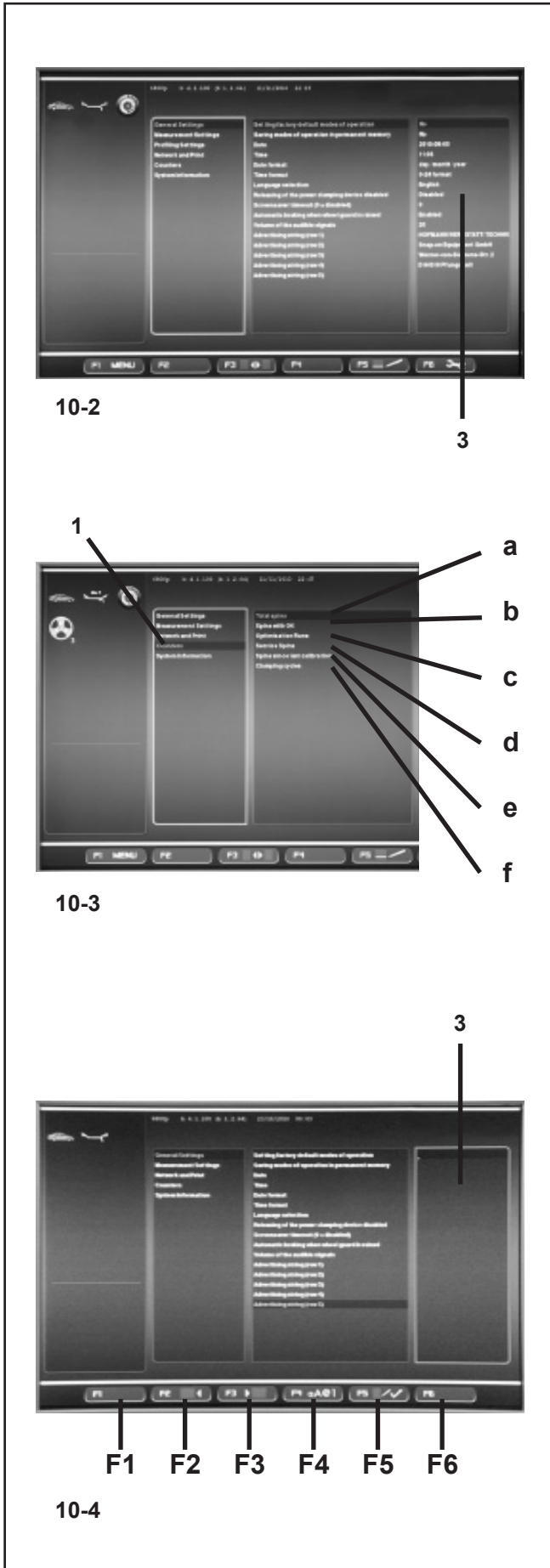

10.3 Input of promotional text

- Select the “General Settings” category in the SETTINGS screen (Fig. 10-2), then select one of the 5 parameters in the central panel “Promotional Text” and enter it using the OK or F5 key.

The TEXT COMPOSITION mode is activated; in the Values field (3, Fig.10-4) a point identifies the position where the text will be entered and the Menu keys are assigned different functions as follows:

Figure 10-4

Menu key functions in TEXT COMPOSITION mode

- F1 Not assigned
- F2 Moves back by one character on the line
- F3 Moves forward by one character on the line
- F4 Opens Character Types menu
- F5 Opens the Menu: Save text, Restore “UNDO” text, Delete text.
- F6 Not assigned.

Setting Parameters

Text field

The text field has five lines of 25 characters each. The spaces between words must be filled with blanks that are located between the Upper Case and Lower Case letter A and Z.

- Use the SCROLL to select the character you wish to insert.
- Using the **F3** key, then move the cursor to the right by one position, insert another letter and continue like this until the text is complete.

Note:

The **F2** key allows you to move the cursor back if you need to return to a previous character.

- At the end of the current line, select the tick sign (**1**, Fig. 10-4b) in Menu **F5**, to save the message .

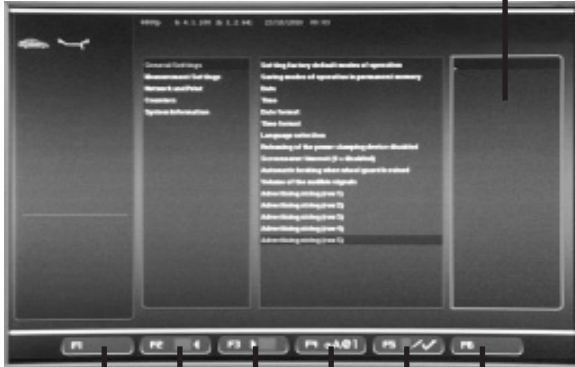

F1 F2 F3 F4 F5 F6

10-4

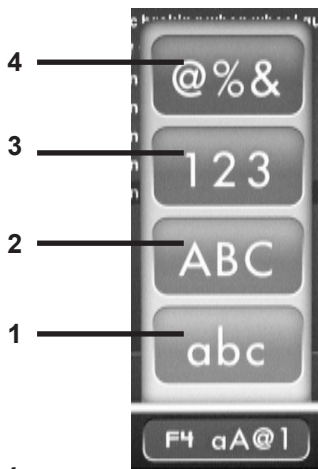

10-4a

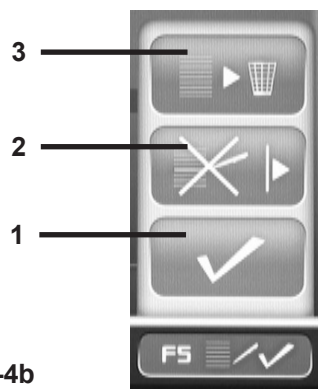

10-4b

Example of how to enter a text

We suggest that you write the text down on a piece of paper first so you can count the number of characters and have a draft to follow when entering text.

For example to enter the following text: **Garage - 1**

Once you have accessed the Values field (**3**, Fig. 10-4) proceed as follows:

- Use the SCROLL command to reach the first letter “**G**” in this example.
- Press the **F3** key to move to the next position in the message to be written.
- Press the **F4** key and using the SCROLL command select the type of Lower Case letter (**1**, Fig. 10-4a), and confirm by pressing **OK**.
- Using the SCROLL command select the letter “**a**”.
- Press **F3**.
- Press **F4** and select the Lower Case letter (**1**).
- Using the SCROLL command select the letter “**r**”.
- Press **F3**.
- Press **F4** and select the Lower Case letter (**1**).
- Using the SCROLL command select the letter “**a**”.
- Press **F3**.
- Press **F4** and select the Lower Case letter (**1**).
- Using the SCROLL command select the letter “**g**”.
- Press **F3**.
- Press **F4** and select the Lower Case letter (**1**).
- Using the SCROLL command select the letter “**e**”.
- Press **F3**.
- Using the SCROLL select the space " "(between letter A and letter Z).
- Press **F3**.
- Press **F4** and select Special Letters (**4**, Fig. 10-4a).
- Using the SCROLL command select “**-**”.

Setting Parameters

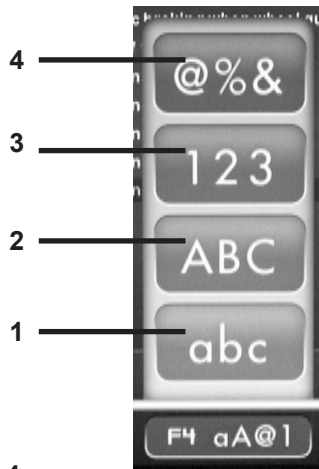

10-4a

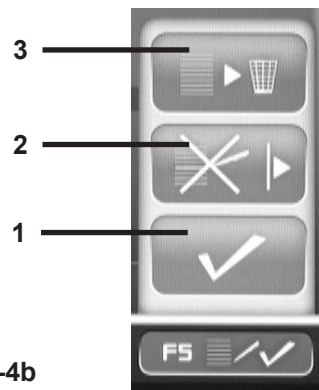

10-4b

- Press **F3**.
- Using the SCROLL select the space " "(between letter A and letter Z).
- Press **F3**.
- Press **F4** and select the type of Number (**3**, Fig. 10-4a).
- Using the SCROLL command select "1".

The text on this line is now complete.

So you can move on to the next line and write something else, or choose an option from the ones available using the **F5** Menu key (Fig. 10-4b).

Saving or deleting text inputs

Having completed a text:

to save it in the permanent memory,

- Press **F5** and select the tick sign "CONFIRM" (**1**, Fig. 10-4b).

or (if you have changed an existing text) to delete the changes you have just made,

- Press **F5** and select "UNDO" in the Menu (**2**, Fig. 10-4b).

Or to delete the entire line of text,

- Press **F5** and select "CANCEL" (**3**, Fig. 10-4b).

If the text that has been set or changed is not confirmed by pressing **OK** or **F5** and the "CONFIRM", tick sign, it will be lost.

Error codes

11. Error codes

Errors in operation	-	Error code E
Warnings	-	Error code H
Fatal error code	-	300 or C10

E1

Rim dimensions were entered incorrectly, or incompletely.

- When the error code is read out, enter data once again.

E2

Wheel guard is not closed.

E5

Range of electrical compensation exceeded
(wheel adaptor has unacceptable unbalance).

- Press STOP or ESC-key.
- Check wheel adaptor, repeat compensation run.

E6

The calibration weight was not fitted for readjustment.

- Press STOP or ESC-key.
- Repeat readjustment.

E7

With this wheel type it is not possible to choose a balancing mode.

- If necessary, choose another wheel type.

E8

Valve position was not entered in electronic unit (error code only in optimisation or minimisation programs).

- Position valve exactly perpendicular to and above main shaft and press the **OP** key.

Error codes

11. Error codes

Errors in operation	-	Error code E
Warnings	-	Error code H
Fatal error code	-	300 or C10

E1

Rim dimensions were entered incorrectly, or incompletely.

- When the error code is read out, enter data once again.

E2

Wheel guard is not closed.

E5

Range of electrical compensation exceeded
(wheel adaptor has unacceptable unbalance).

- Press STOP or ESC-key.
- Check wheel adaptor, repeat compensation run.

E6

The calibration weight was not fitted for readjustment.

- Press STOP or ESC-key.
- Repeat readjustment.

E7

With this wheel type it is not possible to choose a balancing mode.

- If necessary, choose another wheel type.

E8

Valve position was not entered in electronic unit (error code only in optimisation or minimisation programs).

- Position valve exactly perpendicular to and above main shaft and press the **OP** key.

E14

The *power clamp* device is not clamped.

The measuring run has been started with the device not clamped correctly.

Error codes

11. Error codes

Errors in operation	-	Error code E
Warnings	-	Error code H
Fatal error code	-	300 or C10

E1
Rim dimensions were entered incorrectly, or incompletely.

- When the error code is read out, enter data once again.

E2
Wheel guard is not closed.

E5
Range of electrical compensation exceeded
(wheel adaptor has unacceptable unbalance).

- Press STOP or ESC-key.
- Check wheel adaptor, repeat compensation run.

E6
The calibration weight was not fitted for readjustment.

- Press STOP or ESC-key.
- Repeat readjustment.

E7
With this wheel type it is not possible to choose a balancing mode.

- If necessary, choose another wheel type.

E8
Valve position was not entered in electronic unit (error code only in optimisation or minimisation programs).

- Position valve exactly perpendicular to and above main shaft and press the **OP** key.

E14
The *power clamp* device is not clamped.
The measuring run has been started with the device not clamped correctly.

- Release the wheel and then clamp it correctly.

E15
Corrective term of readjustment is out of range.
During readjustment values were determined which exceed, or fall short of, the given adjustment value.

- Use clamping means supplied with the machine, or have basic calibration carried out (service).

Error codes

H0

Wheel running conditions cannot be improved by optimisation.

H1

Further optimisation not recommended but feasible.

H2

Weight minimisation is recommended, optimisation can achieve no further improvement.

H3

Optimisation not recommended.

H20

Correction plane cannot be re-located with the gauge arm for distance and rim diameter.

- Measure the correction plane and switch to dynamic unbalance reading.

H21

The indexed position is not the one for the correction plane in which the adhesive weight is to be fitted with the gauge arm.

- Index the correct position for this correction plane prior to fitting the adhesive weight.

H26

The gauge arm was moved too quickly.

- Return the gauge arm to its home position and then approach it slowly to the weight fitting position once more.

H28

The gauge arm was moved too slow.

- Move gauge arm back into the home position and then bring it once more to the application point for weight placement.

H80

Error codes

Readjustment feature not foreseen during basic calibration. Consequently readjustment by the operator is not possible.

- Press on **STOP** or **ESC** key, error code is deleted.
- Call service for calibration of the machine.

H82

The self-test was disturbed (e.g. by rotating the wheel).

- The message is displayed for 3 seconds, after which the measurement is repeated (max. 10 times), or aborted by pressing the **STOP** or **ESC** key.

H90

The wheel was accelerated too slowly or decelerated too slowly after a measuring run.

If the main shaft does not reach the required speed, check whether the wheel shaft lock is actuated or whether the weight of the wheel is excessive. In this case:

- Release main shaft lock.
- Make sure that the shaft with clamped wheel can rotate freely.
- Turn the wheel by hand and then press on **START** key.
- If the error cannot be remedied: call service.

H91

Speed variations during measuring run. The main shaft lock may be operated.

- Release main shaft lock.
- Make sure that the shaft with clamped wheel can rotate freely.
- Repeat the measuring run.

H948

H949

Fault during self-test at start-up.

The firmware is not aligned with the User Interface version currently in use.

Note:

Wheel balancer operation is not compromised.

- You can continue using the machine.
- Consult the technical assistance department for further information.

Error codes

Fatal error codes

The display shows an alphanumeric code consisting of six digits and/or letters. When messages are read out starting 300XXX the error occurred during the internal operational check, if it is C10XXX it occurred during the self-test after the machine was switched on.

- If necessary, call service.

300 800 or C10 800

Line voltage under 170 V. Balancing is feasible if the motor can drive the main shaft to the measuring speed. Wheel data may be lost.

- Bring the line voltage to within a range of 200 - 230 - 240 Volts with an input transformer (ref. 6705 902).

300 801 or C10 801

Line voltage over 265 V. Damage to the electronic unit of the machine is likely!

- Turn off mains switch!
- Bring the line voltage to within a range of 200 - 230 - 240 Volts with an input transformer (ref. 6705 902).

Any damage resulting from repeated occurrence of this error code is not covered by the guarantee.

300 804 or C10 804

Line voltage over 275 V. Damage to the electronic unit of the machine is likely!

- Turn off mains switch.
- Bring the line voltage to within a range of 200 - 230 - 240 Volts with an input transformer (ref. 6705 902).

Any damage resulting from repeated occurrence of this error code is not covered by the guarantee.

Error messages by means of acoustic signals

Error messages can also be indicated by means of acoustic signals. The service technician can locate and eliminate the corresponding error by means of the number of tones, their frequency and duration (long/short) and the length of the pauses.

- Switch off the machine.
- Call service.

12. User Calibration

If numerous measuring runs are required to balance a wheel because the balance weight sizes and positions need to be repeatedly adjusted, it means the machine is not operating with sufficient measuring precision. If this is the case the operator can electronically calibrate the rotating masses on the machine; which is called User Calibration.

A calibration run takes longer than a regular measuring run. Following User Calibration any residual compensation will be cancelled.



13-1

1



13-2



13-3

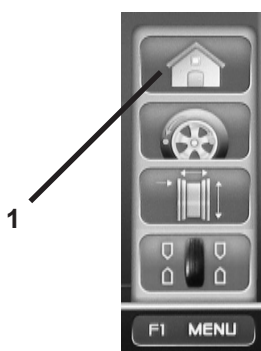

13-4

Important:

User Calibration should only be performed with nothing on the shaft; and with no external tools whatsoever on the wheel holder. ONLY FOR MACHINES WITH A POWER CLAMP: With "p" models only the clamping tool supplied with the machine should be locked.

Readjustment

- Make sure that only the clamping tool (and no other wheel or clamping device) is clamped on the machine shaft.
- Press the F6 key in the SETTINGS menu (Fig. 13-1) and select the CALIBRATION item (1, Fig. 13-1).

The CALIBRATION screen (Figure 13-2) will open.

- Close the wheel guard, press the **START** key and launch the first calibration run (if the run takes a long time it means residual imbalances have been detected).
- Screw the Calibration weight onto the threaded hole in the wheel support flange (Figure 13-3).
- Press the **START** key and launch a second calibration run (to detect correction values).

After the second run the electronic control unit processes the values taken during the calibration runs and writes them in the permanent memory. When this has finished an audible 3-tone signal is heard to indicate that User Calibration has terminated.

- Unscrew the Calibration weight from the flange and put it back in its designated place in the Weight Holder Tray.
- Press the **F1** key to return to the INTRODUCTION screen and select the relative item (1, Fig. 13-4).

Maintenance

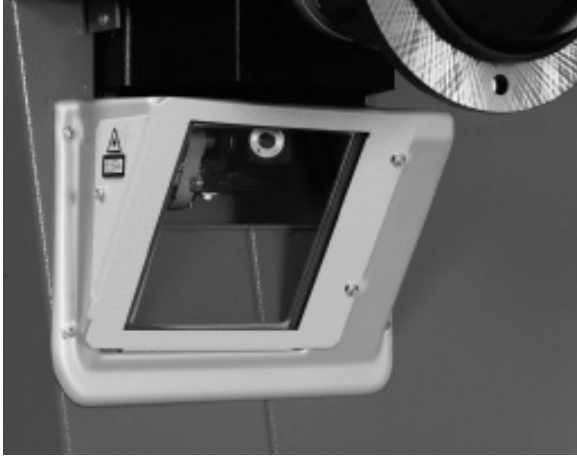

13-2

13. Maintenance

The wheel balancers require almost no maintenance. Their bearings are greased for life and sealed. The drive belt does not require particular checks. If defects occur which cannot be eliminated by the user (error codes not mentioned under § 11. Error codes), contact the after-sales service.

Particular attention should be paid to the cone of the shaft and the clamping means. Balance quality depends considerably on their condition. Keep the tools clean at all times and if they are not in use they lubricate them with a thin film of non-corrosive oil and store them in a sheltered place.

If defects occur which cannot be eliminated by the user (e.g. error codes are displayed that are not mentioned in Chapter 11 Error Messages), contact the Aftersales Service.

13.1 Programmed Cleaning

Every Week:

Laser scanner seating glass

The laser scanner seat (**Fig. 13-2**) has protective glass which requires regular dusting.

- Only use a clean, dry and soft cloth, so as not to scratch the glass surface. In case of oil or grease stains, add an ordinary detergent product for glass.

Every Day:

Cones and Wheel clamping parts

At the end of every working day, after switching off the machine, clean the clamping cones and the Power Clamp lock nut, as well as any special Flanges used, and return to their positions.

Perform the following maintenance operations:

- Clean only with a clean, dry and soft cloth.
- Check the mechanical conditions; the parts must not have any abrasions, dents or incisions.
- Check the wear conditions and, if necessary, clean the wheel clamping shaft and the relative cone clamping ratchets.

If there are any permanent faults, consult the Customer Technical Support service.

13.2 Changing the mains fuse

Refer to Figure 13-3.

- Switch off the unit.
- Unplug the power cable from the power outlet.
- Remove the power cable from the machine mains socket.
- Pull out the fuse holder (2).
- Replace the damaged fuse with another fuse having an identical rating.
- Return the unit to its original functioning state, by following the steps above in reverse.

14. Technical data

Machine dimensions,	see Fig. 14.1
Dimensions of the package HxWxD:	59"x44"x51" (1500mm x 1120mm x 1300mm)
Height of machine with wheel guard open	70" (1762mm)
Weight of machine	332lbs (151 kg)
Shipment weight	409lbs (186 kg)
Power supply	single phase 200–240 V 50/60 Hz
Mains fuses (2 x)	IEC60127 T 250V 6,3A
Motor rating	0.12 kW
Balancing speed	200 rpm
Measuring time in MANUAL mode	3 s
Measuring time in PROFILING mode	9.5 - 24 s
Max. unbalance reading	14oz (400 g)
Resolution of amount reading	0.05/0.25 oz or 1/5 g
Resolution of position reading	0.7 deg.
Working temperature	32 -122 F or 0–50 °C
Relative humidity	10-90 % at 40 °C
Noise level	< 70 dB (A)

Working range

Distance rim – machine	0–290 mm
Rim width	1–20 inches
Rim diameter in MANUAL mode	8"– 30"
Rim diameter in PROFILING mode	14"– 26"
Max. wheel diameter	950 mm
Max. wheel width	530 mm
Max. wheel weight	70 kg

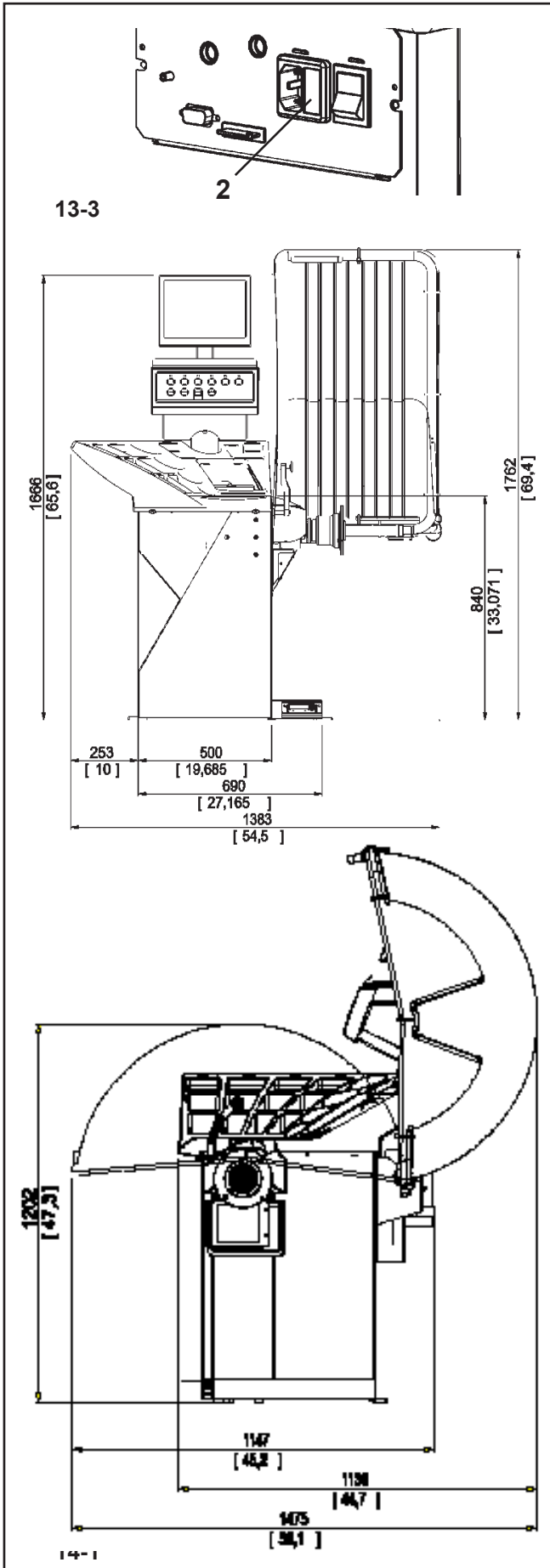

Blank Page



USA

Snap-on Equipment
309 Exchange Avenue
Conway, Arkansas 72032
Tel.: (800) 225-5786

CANADA

Snap-on Equipment
6500 Millcreek Drive
Mississauga, Ontario
Canada L5N 2W6
Tel: (905) 814-0114
Fax: (905) 814-0110

EUROPE MIDDLE EAST AFRICA JAPAN

Snap-on Equipment s.r.l. · Via Prov. Carpi, 33
42015 Correggio (RE) Italy

Phone: +39 0522/733-411 · Fax: +39 0522/733-479 · www.snapon-equipment.eu

www.snapon-equipment.eu

France

Snap-on Equipment France
ZA du Vert Galant · 15, rue de la Guivemone BP97175,
ST Ouen L'Aumone · 95056 Cergy Pontoise Cedex
Phone: +33 (0) 134/48 58-78 · Fax: +33 (0) 134/48 58-70

www.snapon-equipment.fr

Germany

Snap-on Equipment GmbH · Konrad-Zuse-Straße 1
84579 Unterneukirchen
Phone: +49 (0) 8634 / 622-0 · Fax: +49 (0) 8634 / 5501

www.snapon-equipment.de

United Kingdom

Snap-on Equipment Ltd. · 48 Sutton Park Avenue
Reading RG6 1AZ
Phone: +44 (0) 118/929-6811 · Fax: +44 (0) 118/966-4369

www.snapon-equipment.co.uk

Notice: The information contained in this document is subject to change without notice. **Snap-on Equipment** makes no warranty with regard to this material. **Snap-on Equipment** shall not be liable for errors contained herein or for incidental consequential damages in connection with furnishings, performance, or use of this material.

This document contains proprietary information which is protected by copyright and patents. All rights are reserved. No part of this document may be photocopied, reproduced, or translated without prior written consent of **Snap-on Equipment**.