

**VPI SYSTEM III
COMPUTER WHEEL BALANCER**

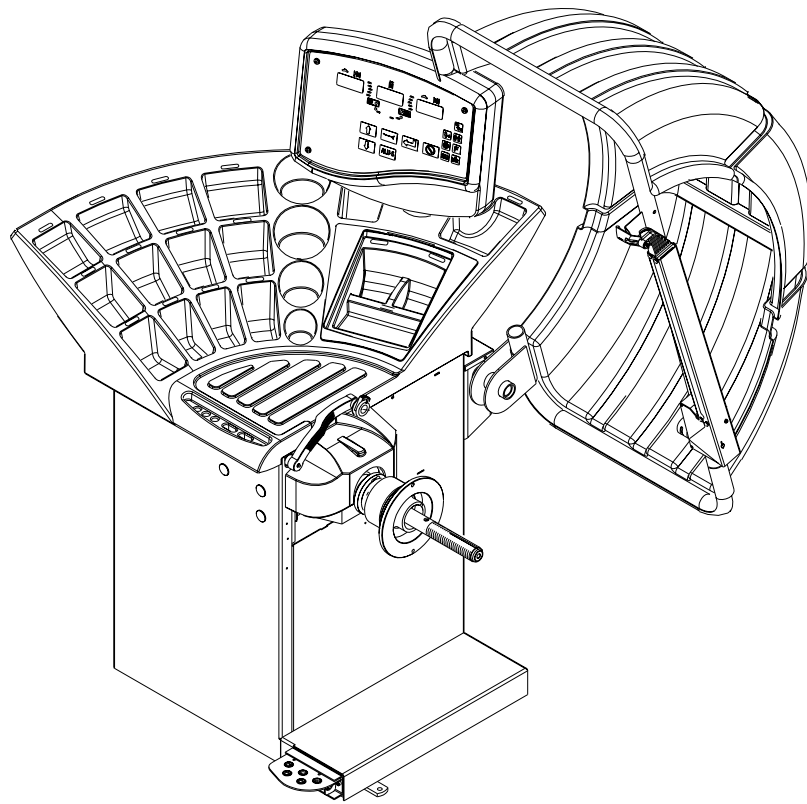

FOR:

PASSENGER CAR/LIGHT TRUCK WHEELS



OPERATION INSTRUCTIONS

Form ZEEWB502B



SAFETY INFORMATION

**For your safety, read this manual thoroughly
before operating the JBC VPI System III Wheel Balancer**

The JBC Model VPI System III Wheel Balancer is intended for use by properly trained automotive technicians. The safety messages presented in this section and throughout the manual are reminders to the operator to exercise extreme caution when servicing tires with these products.

There are many variations in procedures, techniques, tools, and parts for balancing tires, as well as the skill of the individual doing the work. Because of the vast number of wheel and tire applications and potential uses of the product, the manufacturer cannot possibly anticipate or provide advice or safety messages to cover every situation. It is the automotive technician's responsibility to be knowledgeable of the wheels and tires being serviced. It is essential to use proper service methods in an appropriate and acceptable manner that does not endanger your safety, the safety of others in the work area or the equipment or vehicle being serviced.

It is assumed that, prior to using the Model VPI System III Wheel Balancer, the operator has a thorough understanding of the wheels and tires being serviced. In addition, it is assumed he has a thorough knowledge of the operation and safety features of the rack, lift, or floor jack being utilized, and has the proper hand and power tools necessary to service the vehicle in a safe manner.

Before using the Model VPI System III Wheel Balancer, always refer to and follow the safety messages and service procedures provided by the manufacturers of the equipment being used and the vehicle being serviced.



IMPORTANT !! SAVE THESE INSTRUCTIONS -- DO NOT DISCARD !!

IMPORTANT SAFETY INSTRUCTIONS

When using this equipment, basic safety precautions should always be followed, including the following:

1. Read all instructions.
2. Do not operate equipment with a damaged power cord or if the equipment has been damaged - until it has been examined by a qualified authorized service technician.
3. If an extension cord is used, a cord with a current rating equal to or more than that of the machine should be used. Cords rated for less current than the equipment may overheat. Care should be taken to arrange the cord so that it will not be tripped over or pulled.
4. Always unplug equipment from electrical outlet when not in use. Never use the cord to pull the plug from the outlet. Grasp plug and pull to disconnect.
5. To reduce the risk of fire, do not operate equipment in the vicinity of open containers of flammable liquids (gasoline).
6. Keep hair, loose fitting clothing, fingers and all parts of the body away from moving parts.
7. Adequate ventilation should be provided when working on operating internal combustion engines.
8. To reduce the risk of electric shock, do not use on wet surfaces or expose to rain.
9. Do not hammer on or hit any part of the control panel with weight pliers.
10. Do not allow unauthorized personnel to operate the equipment.
11. Do not disable the hood safety interlock system or bypass the intended operation.
12. Use only as described in this manual. Use only manufacturer's recommended attachments.
13. Always securely tighten the wing nut before spinning the shaft.
14. ALWAYS WEAR SAFETY GLASSES. Everyday eyeglasses only have impact resistant lenses, they are NOT safety glasses.
15. Balancer is for indoor use only.

SAVE THESE INSTRUCTIONS

TABLE OF CONTENTS

	General Safety Instructions	Page 2
1.0	Introduction	Page 4
1.1	Safety Notice	Page 4
1.2	Balancer Application	Page 4
1.3	Specifications	Page 5
1.4	Balancer Features	Page 5
1.5	Standard Accessories	Page 6
1.6	Optional Accessories	Page 6
1.7	Dimensions Of The Machine	Page 7
1.8	Installation Area	Page 7
2.0	Installation Instructions	Page 7
2.1	Component Installation	Page 7
2.2	Hood Guard Installation	Page 8
2.3	Width SAPE Arm Installation	Page 8
2.4	Electrical Installation	Page 8
3.0	Terminology	Page 9
4.0	Balancer Operation	Page 10
4.1	Inspection Check list	Page 10
4.2	Wheel Mounting	Page 10
4.2.1	Mounting of Standard Wheels	Page 10
4.2.2	Using the Power Clamp Option	Page 11
4.2.3	Mounting of Light Truck Wheels	Page 12
4.3	Mode Selection	Page 12
4.3.1	Weight Placement Modes	Page 12
4.4	Selecting Operator Preferences	Page 13
4.4.1	Fine Balance Mode	Page 13
4.4.2	Ounce /Grams Conversion	Page 13
4.4.3	Inch/Millimeter Conversion	Page 13
4.4.4	Selection of Operator A/B	Page 13
4.4.5	Operation of Weight Miser™	Page 13
4.5	Entering Rim Parameters	Page 15
4.5.1	Distance and Diameter Entry	Page 15
4.5.2	Rim Width Entry	Page 15
4.5.3	Manual Parameter Entry	Page 15
4.6	Correcting the Imbalance	Page 16
4.7	Verifying Results	Page 16
4.8	Vibration Problems	Page 16
5.0	Matching Program	Page 17
6.0	Optimization Program	Page 19
7.0	Alu-S 2 Plane Program	Page 20
7.1	Alu-S Single - Plane Program	Page 21
8.0	Spoke Mode	Page 22
9.0	Split Weight Mode	Page 23
10.0	User Shaft Calibration	Page 24
11.0	Width SAPE Calibration	Page 25
11.0	Full SAPE Calibration - Width, Distance and Diameter	Page 25
12.0	Maintenance/Troubleshooting and "F" Codes	Page 27
13.0	Maintenance	Page 26
14.0	Trouble Shooting	Page 25

1.0 INTRODUCTION

Congratulations on purchasing the **VPI System III** computer wheel balancer. This wheel balancer is designed for ease of operation, accuracy, reliability and speed. With proper maintenance and care your wheel balancer will provide many years of trouble-free operation.

Instructions on use, maintenance and operational requirements of the machine are covered in this manual.

**STORE THIS MANUAL IN A SAFE PLACE FOR FUTURE REFERENCE.
READ THIS MANUAL THOROUGHLY BEFORE USING THE MACHINE.**

1.1 SAFETY NOTICE

This manual is a part of the balancer product.

Read carefully all warnings and instructions of this manual since they provide important information concerning safety and maintenance.

1.2 BALANCER APPLICATION

*The John Bean wheel balancer model **VPI System III** is intended to be used as a device to balance car, and light truck wheels within the following range:*

<i>Maximum tire diameter</i>	<i>:</i>	<i>44" (1117mm)</i>
<i>Maximum wheel diameter</i>	<i>:</i>	<i>30" (762mm)</i>
<i>Maximum wheel width</i>	<i>:</i>	<i>15" (381mm)</i>
<i>Maximum wheel weight</i>	<i>:</i>	<i>154 lbs (70 kg)</i>

*This device is to be only used in the application for which it is specifically designed.
Any other use shall be considered as improper and thus not reasonable.*

The manufacturer shall not be considered liable for possible damages caused by improper, wrong or non reasonable use.

1.3 VPI System III SPECIFICATIONS

Computerized digital wheel balancer for car, light truck wheels.

Weight Imbalance Accuracy	.05 oz / 1 gram
Weight Placement Resolution	± .7 degrees
Weight Imbalance Resolution:	
Roundoff Mode	.25 oz / 5 grams
Non-Roundoff Mode	.05 oz / 1 gram
Max. Shaft Weight Capacity	154 lbs / 70 kg
Max. Tire Diameter	44" / 1117 mm
Rim Width Capacity	3.0"-20" / 76 mm - 508 mm
Rim Diameter Capacity	8"-30" / 152 mm-762 mm
Balancing Cycle Time.	7 seconds or less
Shaft Speed at calculation	>200 RPM
Electrical	230vac, 1ph, 50-60Hz, 3.2A
Required Work Area	62" x 67" (1574 x1702 mm)
Shipping Weight, complete	430 lbs
Shipping Dimensions	50 x 64 x 62
Machine Dimensions	60w x 62d x 71h
Actual Weight with Accessories	390 lbs
Operating Temperature Range	32-122F / 0-50C

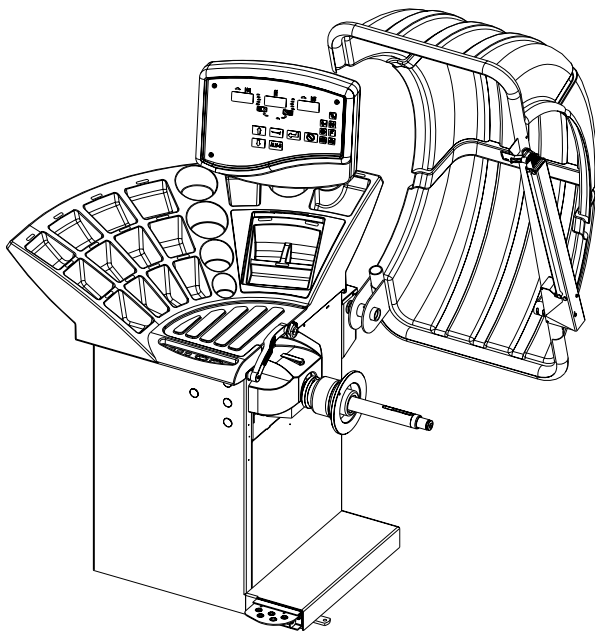

1.4 FEATURES

ACCURACY

- Weight placement accuracy to as low as ± .7°
- Weight imbalance accuracy to 2 grams.
- Self test check with every power up cycle.
- Fast operator calibration.
- Pre-programmed Error Codes indicate procedural errors or safety concerns.

SPEED and DURABILITY

- Automatic "3D" parameter entry. Simply touch the SAPE arm to the inside of wheel and width gauge to the outside, all parameters are automatically entered.
- Distance gauge auto stop feature.
- Quick clamp speed nut offers fast mounting time
- Optional Power Clamp - fastest mounting available
- Captured back spring eliminates having to handle the backing spring.
- Quick cycle time.
- Automatic recalculation if weight positions are changed. No need for re-spinning the wheel.
- Common 40 mm diameter mounting shaft.
- Weight pocket storage tray.
- Easy-to-Read Data display.
- Easy weight tray access.

SOFTWARE VERSATILITY

- Both dual weight Dynamic and single weight Static capability.
- Stop-at-Top features simplifies weight imbalance location
- Match Balance program for reducing weight required.
- Built-in spin counter for monitoring balancer productivity.
- Service code access to all Balancer electronic functions for fast, easy diagnosis.
- Operator selectable roundoff mode.
- 5 Aluminum Modes
- Alu-S mode
- Hidden Weight (Spoke) mode
- Split Weight mode
- Weight Miser™ Feature reduces placed weight and saves shop inventory expense.
- Ounce / Gram toggle from front panel
- Multiple operator feature allows several operators to recall wheel parameters.

1.5 STANDARD ACCESSORIES

Standard accessories (Figures 1, 2, and 3,) included with the VPI System III are:

1	EAM0003J08A	Cone, 85-132 mm / 3.3"-5.2"
2	EAM0003J07A	Cone, 71-99 mm / 2.8"-3.9"
3	EAM0003J06A	Cone, 56-84 mm / 2.2"-3.3"
4	EAM0003J05A	Cone, 43-63 mm / 1.7" - 2.5"
5	EAC0058D07A	Cup - Pressure
6	EAC0058D08A	Disk - Pressure
7	EAA0263G66A	Quick Nut
8	EAM0005D40A	Weight - Calibration
9	EAM0021D90A	Standard 40mm Stub Shaft
10	EAA0247G21A	Caliper - Rim Width
11	EAC0060G02A	Flange - Cover, Hook
12	EAM0006G01A	Pin - Accessory
13	58839	Weight Pliers
14	EAM0005D34A	Fastening Rod
15	EAC0058D15A	Soft Protector ring

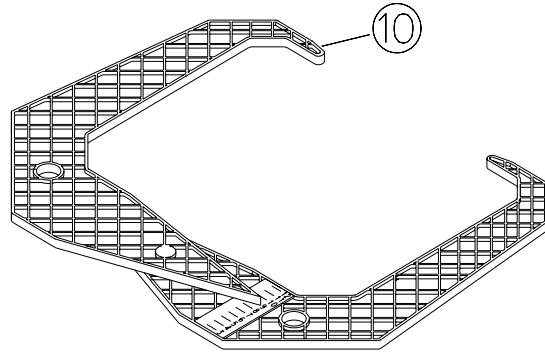

Figure 2

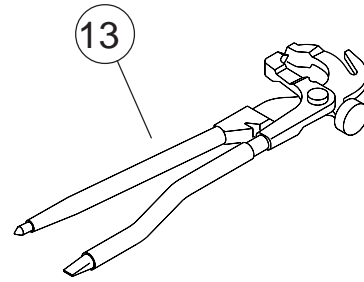
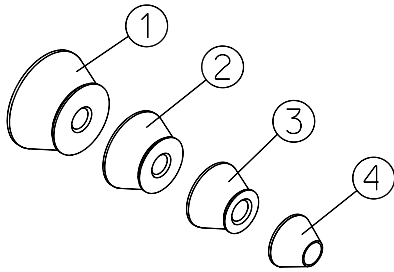

Figure 3



1.6 OPTIONAL ACCESSORIES

Unilug adapter kit - pn 110614

Truck cone kit - pn 110612

Motorcycle adaptor kit - EAA0260D80A

Power Clamp Option Accessories

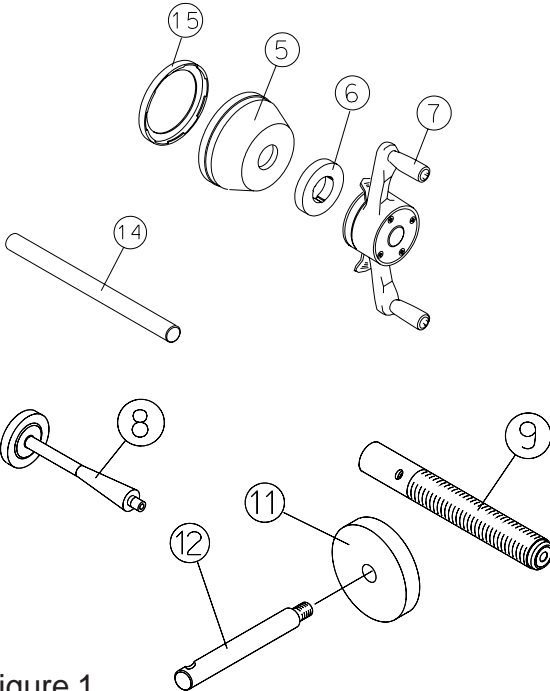
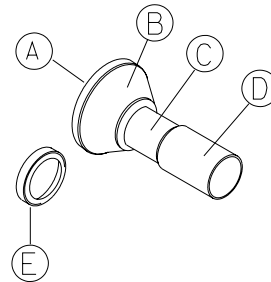

Figure 1



A	EAC0058D15A	Soft Protective Ring
B	EAC0058D07A	Cup - Large Pressure
C	EAA0283D53A	Power Clamp Nut
D	EAM0005D54A	Plastic Sleeve
E	EAC0058D08A	Small Pressure Disk

PRE-INSTALLATION CONSIDERATIONS

1.7 DIMENSIONS OF THE MACHINE

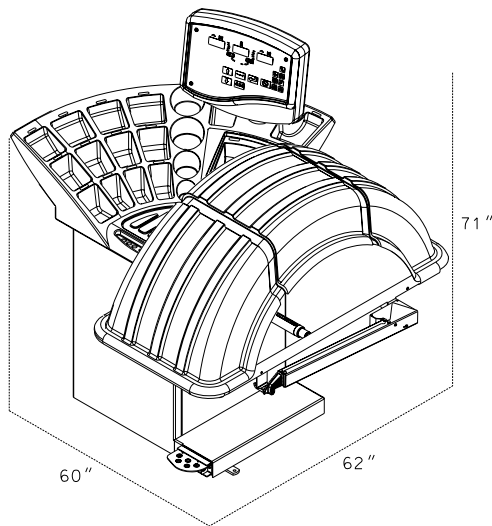

Figure 4 - Actual Footprint Dimensions.

1.8 REQUIRED INSTALLATION AREA

Make sure that from the operating position the user can see all of the machine and the surrounding area.

The operator should prevent non authorized persons and/or objects from entering the area which may create potential hazards.

The machine should be installed on a stable level floor. Do not install the machine on a uneven floor.

If the balancer is to be installed on a raised floor, the floor must have a capacity of at least 110lbs per sq ft. (5000 N/m² - 500 kg/m²).

It is not required to secure the machine to the floor.

Install the machine in a dry, covered area.

The installation of the machine requires a working area of at least 62" x 67" (1574 x 1702 mm) (Figure 5).

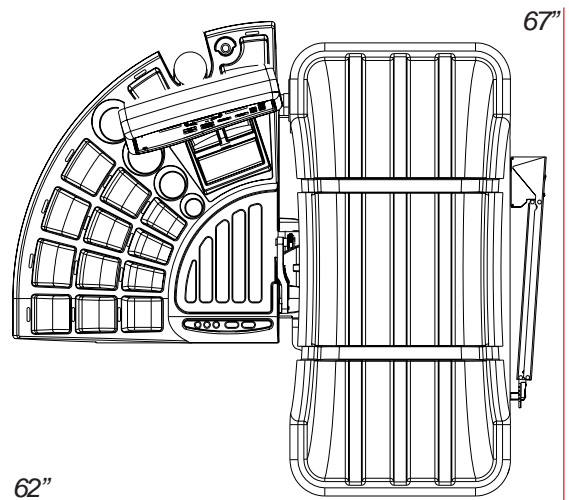

Figure 5 - Recommended Work Area

2.0 INSTALLATION INSTRUCTIONS

CAUTION! CAREFULLY REMOVE THE BALANCER FROM THE PALLET.

Remove the hardware that secures the machine to the pallet and slide the balancer onto the floor where it is to be installed.

THE UNIT IS HEAVY AND THE WEIGHT IS NOT EVENLY DISTRIBUTED.

DO NOT LIFT THE BALANCER BY THE SHAFT.

DROPPING THE UNIT MAY CAUSE PERSONAL INJURY OR EQUIPMENT DAMAGE.

2.1 COMPONENT INSTALLATION

Mounting the Standard Shaft Adapter

IMPORTANT!

CHECK THAT THE SURFACES ARE PERFECTLY CLEAN AND NOT DAMAGED. AN INCORRECT MOUNTING MAY RESULT IN SIGNIFICANT IMBALANCE. UNITS SUPPLIED WITH THE OPTIONAL POWER CLAMP ARE SHIPPED ASSEMBLED.

A. Mount the threaded shaft onto the arbor of the balancer. Tighten firmly using supplied rod. (Figure 6).

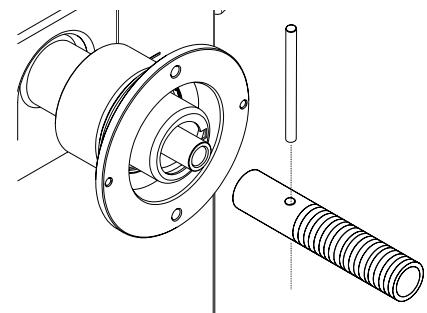

Figure 6

B. Install the 4 accessory pins (Figure 7). Tighten firmly.

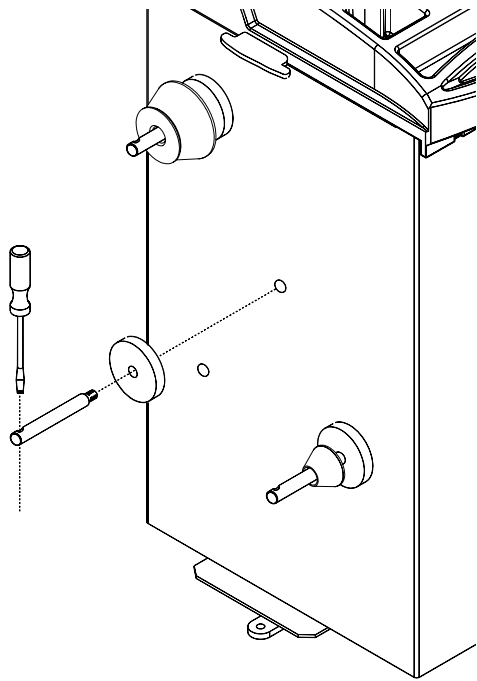

Figure 7

C. Place accessories onto the accessory pins.

2.2 HOOD GUARD INSTALLATION

The safety hood guard is standard equipment and must be installed prior to use.

Refer to Figure 8 for hood guard installation.

Parts Required:

- (1) Hood Guard Assembly
- (1) 3/8" - 16 x 2" HHCS
- (1) 3/8" x 16 Keps

Position the hood guard in the raised (up) position.

Slide the hood guard support tube over the frame pivot shaft protruding from the right side of the balancer cabinet.

Line up the mounting holes in both the pivot shaft and the guard support tube. Secure the guard with 3/8" hardware.

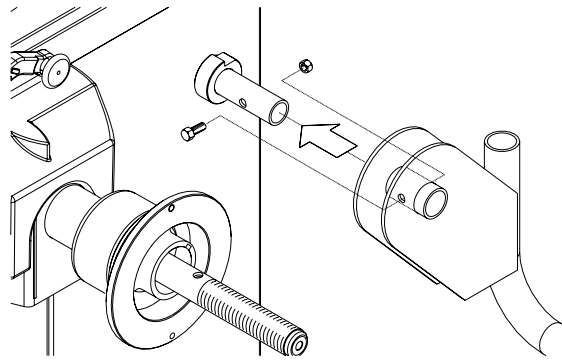

Figure 8

2.3 WIDTH SAPE ARM INSTALLATION

Connect the SAPE arm cable to the harness connector exiting the rear of the cabinet. This connector is keyed to be inserted only one way. Do not force connection.

2.4 ELECTRIC INSTALLATION

ANY ELECTRICAL WIRING MUST BE PERFORMED BY LICENSED PERSONNEL.

ALL SERVICE MUST BE PERFORMED BY AN AUTHORIZED SERVICE TECHNICIAN.

Check on the plate of the machine that the electrical specifications of the power source are the same as the machine. The machine uses 230VAC, 50-60Hz, 1Ph, 3.2 Ampere.

NOTE:

ANY ELECTRICAL OUTLET INSTALLATION MUST BE VERIFIED BY A LICENSED ELECTRICIAN BEFORE CONNECTING THE BALANCER.

NOTE:

THIS MACHINE PERFORMS A SELF-TEST ROUTINE ON START-UP. THERE WILL BE A DELAY OF SEVERAL SECONDS BEFORE THE DISPLAY IS ACTIVATED.

3.0 TERMINOLOGY

Before using the wheel balancer it is suggested that you become familiar with the terminology and features of the machine's components. Refer to Figures 2-1 and 2-2 for identification and location.

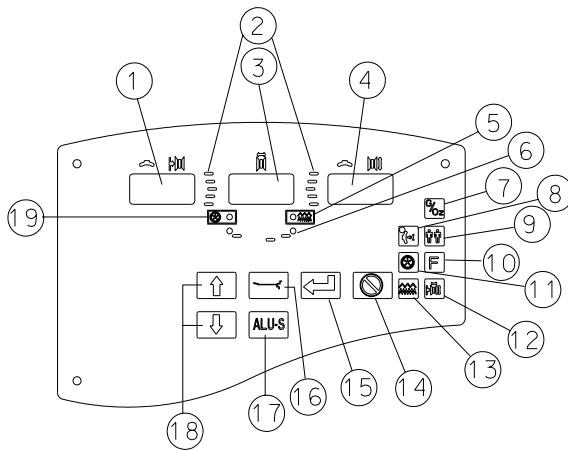

1. **Inside Weight Amount and Function Display Window** - Shows inside or left weight amount and various operation messages.
2. **Position Indicator LEDs** - Displays the location for wheel weight placement.
3. **Middle Display** - Used to display wheel parameters or messages.
4. **Outside Weight Amount and Function Display Window** Shows outside or right weight amount and various operation messages.
5. **Fine Mode Indicator** - When lit indicates the balancer is in the "Fine Mode".
6. **Weight Mode and Placement Display** - Displays a pictorial reference of the chosen balance mode.
7. **Oz/Gr** - Toggles between display values in Ounces or Grams.
8. **Weight Miser™** - Toggles the Weight Miser™ feature on and off. The LED is illuminated when active.
9. **Multi-Operator Selection** - This key toggles between four operators designated as A, B, C, and D then P1 thru p4 for more stored parameters. Wheel parameters are recalled upon command.
NOTE: ROTATING THE SHAFT IN EITHER DIRECTION WILL ALSO VARY DISPLAYED VALUES.
10. **Function Button** - Used to activate the various functions. Press this button followed by pressing the *up* or *down* arrow buttons until the desired number is displayed. Press the "Enter" button to active the function.
11. **Spoke Mode** - Activates the Spoke Mode.
12. **Parameters - Rim Offset** - Key is used to enter the rim offset position using numbers from the distance gauge. **Rim Diameter** - Enter the rim diameter. Read the size stated on the tire sidewall. **Rim Width** - Press this key to enter the rim width. Use the rim width calipers for measurement

13. **Fine Weight Toggle** - In normal mode "FIN OFF" round off is 0.25 oz or 5 gram, fine mode "FIN ON" round off is 0.05 oz. or 1 gram.
14. **Cancel** - Pressing this key interrupts any process.
15. **Enter** - This key activates whatever selection has been requested, it also spins the wheel if guard frame is down.
16. **Mode Selection** - A series of placement locations for custom weight location. Useful for the wide variety of custom wheels on today's market.
17. **ALU-S** Activates the ALU-S mode.
18. **Up and Down Value** - Buttons are used to raise or lower displayed values for parameter entry or function code activation.
19. **Spoke Mode Indicator** - When lit indicates the balancer is in the "Spoke Mode".

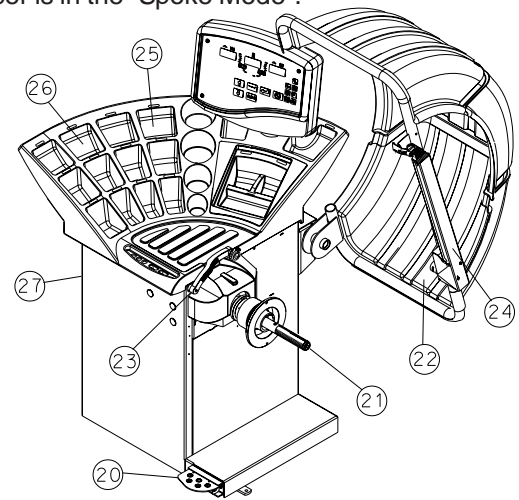

20. **Foot Operated Shaft Lock** - A foot operated shaft lock is used to stabilize the shaft during the weight placement process.
21. **Shaft Adapter** - A common 40 mm size shaft is used. The easily removable shaft can be replaced for service or during use of certain wheel adapters.
22. **Wheel Guard** - The standard wheel guard is a safety feature for prevention of operator injury in the event of loose weights, debris or wheel mounting failure. The balancer is programmed to spin upon guard closure as well as brake when the guard is raised.
23. **Semi-Automatic Parameter Arm** - Rim distance is automatically input with the SAPE. The SAPE is also used in several procedures for determining accurate rim profiles.
24. **3DP SAPE** - Rim width is automatically input with the SAPE by touching the outside of the wheel where the weight will be located.
25. **Display** - Easy to read, user friendly display featuring large LEDs and one button functions.
26. **Weight Storage Tray** - Generous storage for a variety of weight profiles and sizes as well as built in storage pockets for the standard centering cones.
27. **Accessory Storage** - Four sturdy side mounted pegs are supplied for storage.

4.0 OPERATION OF THE BALANCER

WARNING: For operator safety please read and follow the precautions outlined on pages 1 and 2 of this manual.

NOTE: READ ALL INSTRUCTIONS BEFORE PROCEEDING WITH OPERATION OF THE BALANCER.

All balancer functions are input into the main computer through the large easy to read touch panel. Although each wheel tire assembly differ in some ways all balancing jobs require basically the same procedure. The order of events to take place are:

1. Inspection of the wheel/tire assembly
2. Mounting wheel onto shaft or adapter
3. Selection of Balancing Mode and Preferences
4. Entry of wheel parameters
5. Spinning the wheel
6. Applying the recommended weight
7. Check spin if desired
8. Dismounting the wheel

The following operation instructions will follow the basic outline above.

4.1 CHECK LIST - INSPECTION

Observe Before Balancing Wheel

1. Check for proper air pressure. If not correct, inflate to correct pressure.
2. Check for any foreign material inside tire. If present, remove before balancing tire.

WATER IS FOREIGN MATERIAL!

3. Remove old weights — old weights may be improper value or in wrong location.
4. Be sure tire and wheel are free of excessive dirt, rust and large stones. Use wire brush on back side of wheel if necessary.

4.2 WHEEL MOUNTING

Nearly all standard wheels and many alloy wheels have accurately machined center holes, and they should be mounted with center cones. Accurate balancing depends on accurate mounting of the wheel and correct seating of the cone in the pilot hole. Insure that the wheel is centered on the shaft exactly as it will be mounted to the vehicle.

Before starting any balancing procedure it is very important that the wheel is mounted on the machine with the proper adaptors. An incorrect centering of the wheel will result in considerable imbalance.

There are many types of wheels and John Bean supplies adaptors of high quality and durability for the large majority. However if you meet special wheels which may require a specific adaptor, call your authorized John Bean distributor.

Rims may be divided into these major groups:

1. **Car rims with a true center hole.**
2. **Car rims without a center hole.**
3. **Car rims with an untrue center hole.**
4. **Light truck rims.**

4.2.1 Standard Wheels (back cone mount)

Mount the wheel as detailed below in Figure 11:

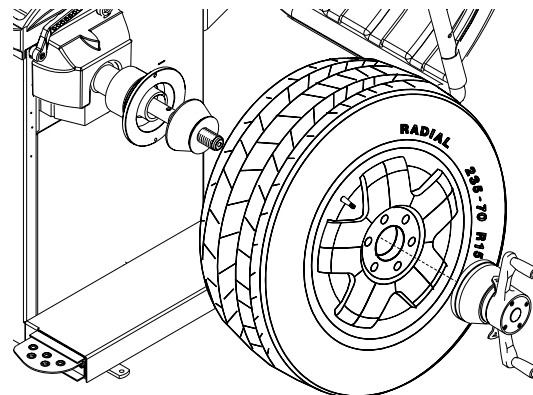
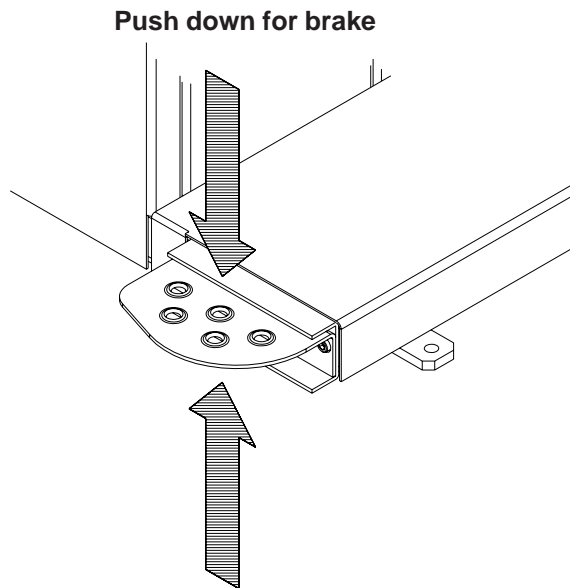

Figure 11

1. Mount proper cone against spring plate.
2. Mount wheel on shaft in the same manner as you would on the car.
3. Mount pressure cup on shaft and place against outside of wheel, follow with the Quick-nut.
4. Tighten Quick-nut securely with both hands. To operate the Quick-nut pull the lock-unlock lever. Slide the Quick-nut on the threaded shaft. When in contact with the rim, release the unlock lever and tighten firmly. To assist in centering the wheel properly, rotate the wheel on the shaft while tightening the quick nut.



Lift up for power clamp operation

Figure 12a

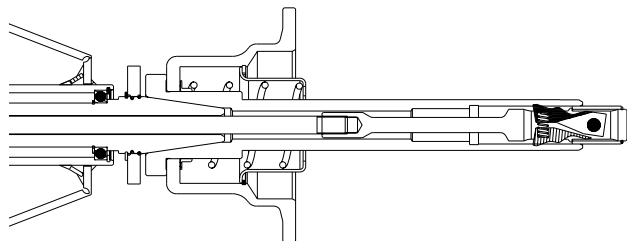

Power Clamp with jaws all the way OUT

Figure 12b

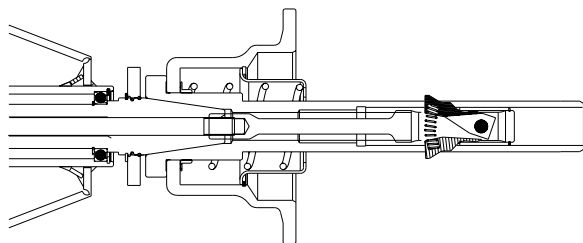

Power Clamp with jaws all the way IN

Figure 12c

4.2.2 POWER CLAMP OPTION

POWER CLAMP PEDAL

Shaft Lock

The main shaft is locked when the pedal is **depressed**. This holds the wheel in the correction position for correct fitting of the correction weights. See Figure 12a.

This lock is designed only to facilitate orientation of the wheel and must not be used for braking the main shaft.

Power Clamp Operation.

Lift upward to engage the power clamp jaws when the lock nut is placed on the shaft.

Lift upward again to release the clamp nut.

NOTE: The first time the unit is operated after power-up, make sure the power clamp engaging jaws are in the outer most position and ready for use. An Error of “E14” may result if the unit cannot accurately determine the clamping jaw position. Simple press “CANCEL” to continue, lift the pedal again to cycle and the power clamp will learn its new position. See Figures 12b and 12c.

1. Mount proper cone against spring plate.
2. Mount wheel on shaft in the same manner as you would on the car. See Figure 12d
3. Mount the Power Clamp nut along with proper pressure cup.
4. To operate the power clamp, lift the foot pedal to engage the clamp. Lift pedal again to release the nut.

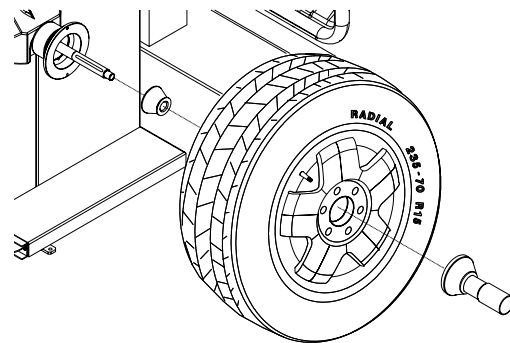

Figure 12d

! WARNING!
FAILURE TO TIGHTEN QUICK NUT SECURELY MAY RESULT IN SERIOUS PERSONAL INJURY.

DO NOT USE A HAMMER TO TIGHTEN THE QUICK NUT.

TO RELEASE THE QUICK NUT, UNSCREW A FEW TURNS TO REDUCE THE AXIAL PRESSURE, THEN PRESS THE UNLOCK LEVER AND SLIDE AWAY FROM THE SHAFT.

5. Check that the wheel rotates true by turning the wheel several revolutions while noting any excessive runout.

4.2.3 CENTERING LIGHT-TRUCK WHEELS

An optional offset spacer may be required for some light truck wheels and reverse-offset wheels that must be moved away from the balancer mounting flange. The extension adaptor is often used with the 5-1/4 inch diameter light truck cone.

Install the spacer on the mounting flange, then mount the wheel, using the front cone method (Figure 13)

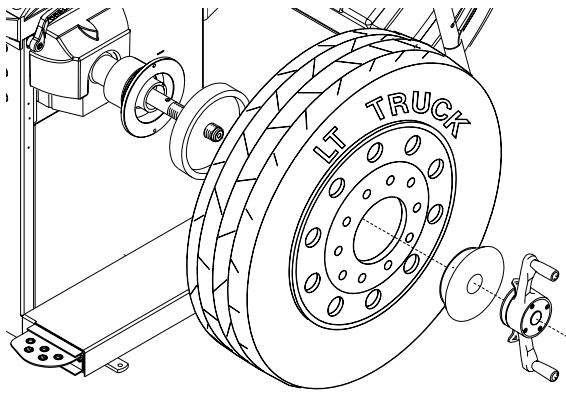

Figure 13

4.3 MODE SELECTION

The majority of balancing takes place in the default 2-plane dynamic mode which is displayed as "2 PL" (location 1). Hammer-on clip weights will be placed on both inside and outside of the rim edge. If required, select an optional weight placement mode by pressing the **Mode** button until the appropriate placement mode is displayed.

4.3.1 WEIGHT PLACEMENT MODES

Before spinning the wheel (although it may be done afterwards) choose the appropriate balancing mode for the wheel. To select the various placement modes press the **Mode** button until placement LEDs indicate desired placement position.

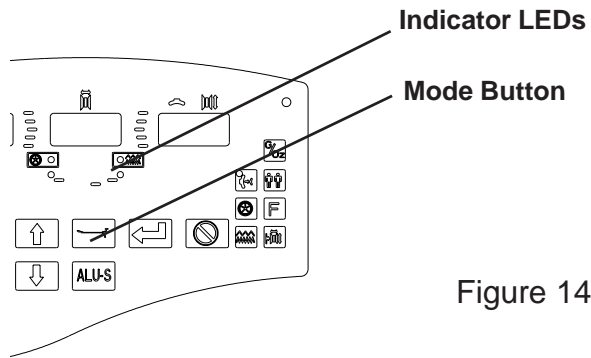

Figure 14

The balancing modes available are:

A. DYNAMIC (two planes), suggested for all steel rims. In this case the wheel weights must be clipped onto the rim edges. This function is selected as a default and the LEDs corresponding to the wheel weight location are lit on (Figure 15).

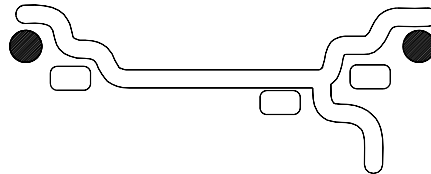

Figure 15

B. STATIC (single plane - Figure 16). Suggested for narrow rims (3" or less). Use a single corrective weight placed in the center or inner edge of rim as illustrated in Figure 16.

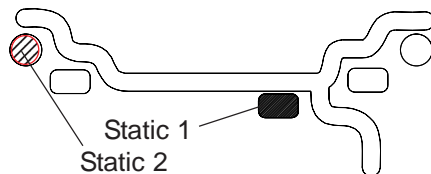

Figure 16

C. ALUMINUM MODES. Balancing using a combination of hammer-on and adhesive weights as shown in Figures 17 thru 21.

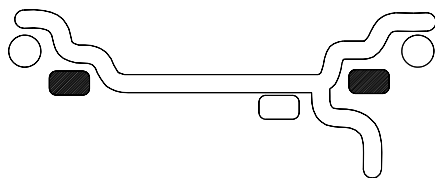

Figure 17 ALU 1

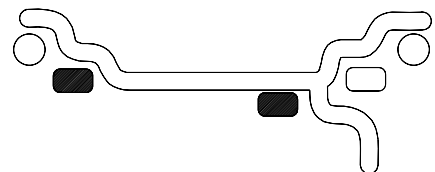

Figure 18 ALU 2

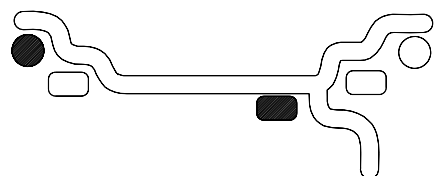

Figure 19 ALU 3

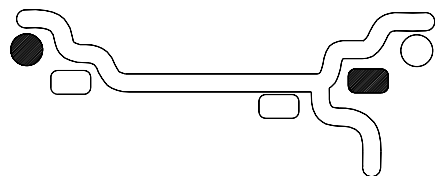

Figure 20 ALU 4

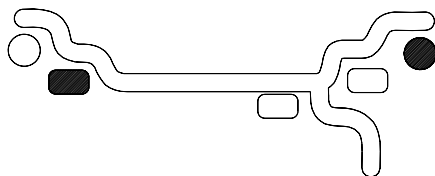

Figure 21 ALU 5

TO RETURN TO THE *DYNAMIC* PROGRAM FROM ANY OF THE *ALU* PROGRAMS, JUST PRESS **Cancel/Stop**.

4.4 SELECTING OPERATOR PREFERENCES

4.4.1 FINE BALANCING MODE

This balancer measures with the maximum precision available all the time, 1g / 0.05 oz, however values below 5g / 0.25 oz are shown as zero while in the normal operating mode. Values exceeding 5g / 0.25 oz are rounded to the amount of the nearest commercial wheel weight.

Press the **Fine Mode** button (number 5 on page 9) to toggle the display resolution between 5g / 0.25 oz and 1g / 0.05 oz.

4.4.2 OUNCE/GRAMS CONVERSION

Press the OZ/Gr button on the touch panel to toggle between ounces and grams for weight amount display. Pressing again will revert to the previous mode.

4.4.3 RIM DIAMETER IN MILLIMETERS

The rim diameter is normally displayed in inches, however if the value in millimeters is desired, press the **F** button followed by the **UP** or **Down** arrow button until "**F 7**" is displayed". Press "**ENTER**". Repeat the above operation to convert back to inches.

Example: "dIA ICH" = inches
 "dIA ---" = millimeters

4.4.4 OPERATOR SELECTION

Select the desired operator designated A,B,C, D or P1 thru P4. The System III Balancer can store wheel parameters of four operators and four other stored parameters. The Operator button toggles between the stored locations with each depression.

4.4.5 Weight Miser™ is a software program that determines if there is the possibility to remove sufficient vibration from a tire and wheel assembly by applying a lower amount of weight than the normal balance function recommends. The amount of residual imbalance left on the tire and wheel assembly is determined by the residual threshold tolerance setting.

Assuming that an amount of residual imbalance accepted currently by the automotive industry standards is 5 grams for static imbalance and 10 grams for dynamic imbalance, a new feature Weight Miser™ allows the tire shop to achieve wheel balancing using less – smaller – balancing weights.

NOTE: It must be very clear that the feature works assuming that some residual imbalance can be left on the wheel. The tire shop will save weight, but wheels will be balanced with a lower degree of accuracy.

Weight Miser™ Operation

1. The Weight Miser™ function is enabled or disabled by depressing the Weight Miser™ button on keyboard. When the button is pressed, the machine displays “SAV ON” for one second. Then machine displays the weights in Weight Miser mode. 
2. Pressing the Weight Miser™ button again, the machine displays “SAV OFF” and returns to the normal balancing mode.
3. The weight savings are stored in memory to be recalled later.
4. The Operator can check the total savings of the Weight Miser™ by entering “Function Code” F89 as described below.
 - (a) Enter F89, the machine displays "SAV ING" for 1 second.
 - (b) The display will then show the total amount weight saving in grams or ounces depend on the setting of the weight unit.
 - (c) The maximum total amount of saving weight can be displayed is 999,999 gram (= 1 ton) or 999,999 oz (= 62,500 lbs).
 - (d) Next, Press the F button, the machine displays "Ent Pri ce " .
 - (e) Use the UP and DOWN buttons to enter the unit price of weight in cents, such as .75 cents per ounce.
 - (d) Pressing the F button again machine displays the total a mount money saved by Weight Miser function.
 - (f) The value is rounded to the nearest dollar (if weight unit is ounce) or Euro (if weight unit is grams).
 - (g) If continuously press F button, machine displays "Erase", " 1 1 1", " 2 2 2", " 3 3 3" and finally "CLE AN SAV". At that time the memory is reset to 0.
 - (h) Press [STOP] at any time to exit F89.

4.5 ENTER RIM PARAMETERS

4.5.1 Rim Distance (offset) and Diameter -

Move the rim offset arm to the inside edge of the rim, touch the pointer to the rim edge, touch the tip of the width arm to the outside rim edge where weights will be placed as illustrated in Figure 22. Hold arms steady for about a second. The beeper will sound when the parameter values are calculated and entered automatically. Return the arms to its home rest position on the balancer. Do not allow the measurement arms to "dangle".

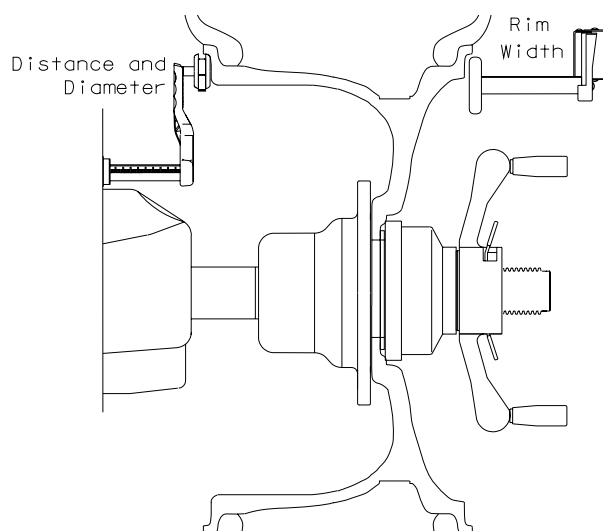

Figure 22

4.5.2 Manual Parameter Entry

In the event of automatic gauge failure, ANY parameter value can be input manually.

4.5.2.1 Manual Distance Entry - Move the distance gauge arm to touch the inner edge of the wheel where weights are to be placed and observe the reading on the scale of the distance gauge. Press manual Wheel **Parameter** button (#11 page 9) followed by pressing the **UP** or **Down** arrow button until value is displayed in the left display window.

4.5.2.2 Measure Rim Width Manually using rim width calipers. Measure wheel where corrective clip-on weight would be applied, Figure 23. Enter the measured width by pressing the **Parameter** button followed by the **UP** or **Down** arrow button until the desired value appears in the right display.

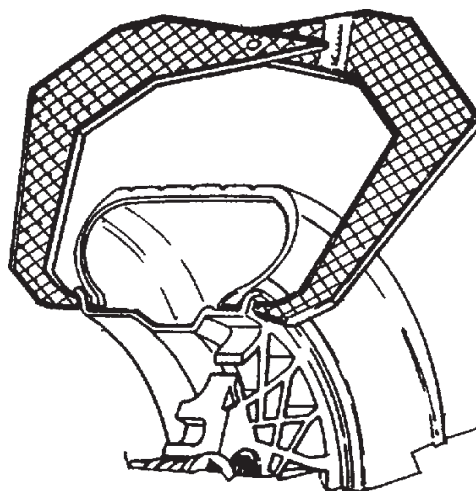

Figure 23

4.5.2.3 Manual Rim Diameter Entry - Select the Manual Parameter button. Read the rim diameter marked on the sidewall of the tire (Figure 24). Enter the measured rim diameter by pressing the **Parameter** button followed by the **UP** or **Down** arrow button until the desired value appears in the right display.

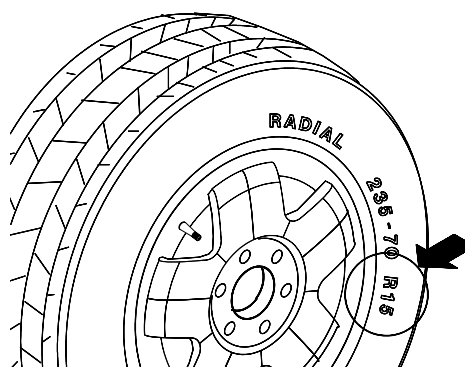

Figure 24

NOTE: For a more precise balancing of performance wheels, an "ALU-S" Mode is available for precision determination of wheel parameters. This feature allows exacting placement of corrective weights as well. See Page 20 for detailed instructions.

NOTE: The parameter arms must be in the Home rest position when the balancer is powered up. This establishes the arm starting position.

4.6 CORRECTION OF THE IMBALANCE

NOTE: Before spinning the wheel make sure proper eye protection is worn by all personnel in the vicinity of the balancer.

A. Spin the wheel by lowering the wheel guard or by pressing the **Enter** button. When the balancing cycle is completed the wheel will stop automatically and the imbalance values will appear on the LED's.

NOTE: DO NOT USE THE FOOT OPERATED SHAFT LOCK AS A BRAKE, IT IS INTENDED TO BE USED ONLY TO PREVENT SHAFT ROTATION WHILE PLACING CORRECTIVE WEIGHTS.

B. Read the imbalance value on the outer display. Values are displayed in ounces but can be displayed in grams if required and are automatically rounded to the nearest commercial wheel weight.

4.6.1 PLACING THE CORRECTIVE WEIGHT

Raise the wheel guard and turn the wheel until the displays of the outer plane imbalance position indicator are illuminated green. A tone will sound indicating top dead center. Apply the wheel weight at twelve o'clock position. Use the foot operated shaft lock to prevent shaft rotation while placing weights.

C. Correct the inner plane in the same manner.

4.7 VERIFICATION OF THE RESULTS

Lower the wheel guard to spin the wheel again and check that the readout is **"0.00"** **"0.00"** If a residual imbalance is displayed:

A. Check the rim parameters, if entered value is incorrect, correct as needed. Imbalance values will be re-computed after re-spinning wheel.

B. Check if the balancing mode selected is the most appropriate. If not, choose the right mode and re-spin.

C. The wheel weight could have been placed at a wrong position. To check this, position the wheel at the correction position for the outer plane. If the wheel weight previously attached is in sector 'L' or 'R' (Figure 25), move the wheel weight up about 1" (2.54cm).

If the wheel weight is in sector 'D' cut a piece of the wheel weight of an approximate value corresponding to the value shown on the right display, or replace the wheel weight with a lighter one.

If the wheel weight is in sector 'U' add a weight of value indicated by the display or replace the wheel weight with a heavier one. Repeat the same operation for the inner plane.

NOTE: If this situation is repeated, your machine may be out of calibration and a calibration operation might be required as instructed on page 22.

D. If an *ALU* function was selected ensure that the wheel weights have been placed in accordance to the program chosen.

E. Check that the quick nut is tight and that the wheel is not slipping against the backing collar.

F. Check that the wheel and adaptors are clean.

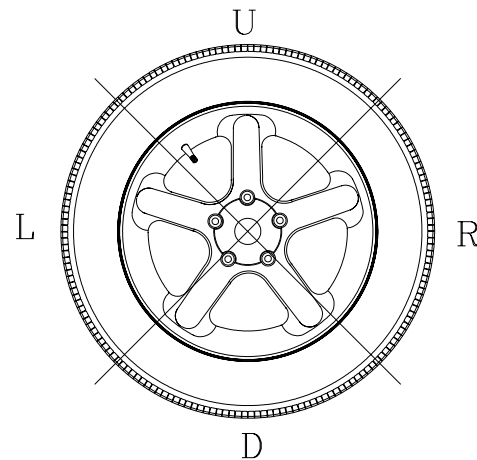

Figure 25

4.8 VIBRATION PROBLEMS

If vibration is still present after balancing, check the following possible sources of vibration:

1. Stones caught in the tire tread.
2. Tire slippage on the wheel.
3. Incorrectly mounted wheel.
4. Imbalanced wheel covers.
5. Excessive radial or lateral runout in the tire or wheel.
6. Damaged wheel bolt holes.
7. Worn universal joints.
8. Imbalanced brake rotors or drums.
9. Worn or damaged balancer accessories.

5.0 TIRE MATCHING PROGRAM - F90

Tire matching assists the user in determining the best possible mating of the tire and rim. The mating of tire and wheel normally allows the least amount of additional weight required for balancing and total runout.

The matching program is helpful when:

- Excessive radial runout is noticed.
- The balancer calls for weights in excess of 2 oz. on either plane in the *Dynamic* mode.

The **VPI System III** computer wheel balancer features a matching program capable of two levels of resolution:

Dynamic, to rotate *and* reverse the tire on the rim for optimum rim and tire matching.

Static, when the tire has an ornate sidewall or directional tread and cannot be reversed on the rim.

INSTRUCTIONS:

1. Press the "F" button followed by pressing the **UP** or **Down** arrow button until the display reads "F" "90", release the "F" button.

When activated the machine displays "--- ACH---" for one second followed by "PUT VAL tOP". This instructs the operator to rotate the wheel so the inflation valve is at 12 o'clock. See *Figure 26*. Press "F" to store the valve position, the display will then read "ACH SPN 1".

NOTE: THE F BUTTON CAN BE PRESSED MORE THAN ONCE, EVERY TIME THE F BUTTON IS PRESSED, THE VALVE POSITION IS REMEMBERED BY MACHINE AS A REFERENCE POINT.

2. Lower the wheel guard to spin the wheel, when the shaft reaches the balancing speed, the display reads "--- ACH ---" accompanied with a short beep.

3. After spinning the shaft brake engages and the display reads "tur tir---" and "CrS tOP---" alternatively.

(1) The operator should turn the wheel and mark an X at the 12 o'clock when the valve is at the 6 o'clock position. *Figure 27*

(2) Remove the wheel assembly from the balancer and deflate and rotate the tire on the rim so the valve points to the cross mark on tire as shown in *Figure 28*

4. After inflating the tire and remounting on shaft, press F Button. The machine displays "PUT VAL tOP" again. Operator should turn the wheel so the valve is at 12 o'clock. Press the "F" button to program the valve position.

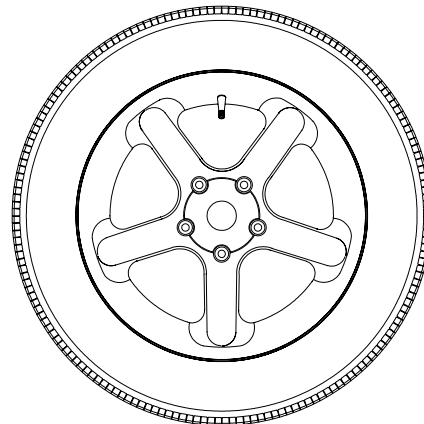

Figure 26 - Step 1, valve top, press "F"

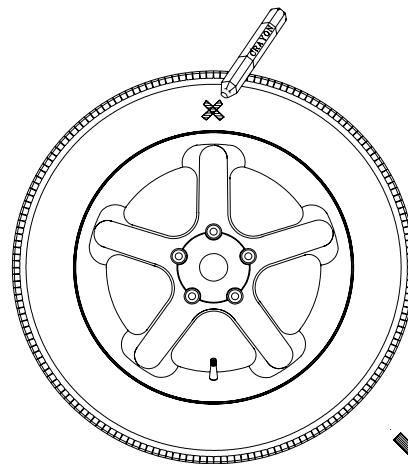

Figure 27 - Step 2, valve at bottom, mark top of tire with X, press "F"

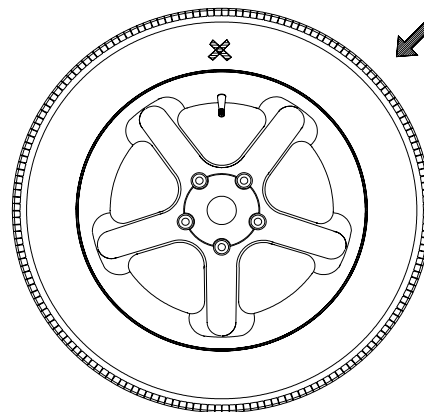

Figure 28 - Step 3, rotate tire on wheel so the valve and X mark line up. Rotate assembly to TDC, press "F".

NOTE: THE "F" BUTTON CAN BE PRESSED AS OFTEN AS NECESSARY, WITH EVERY PRESS THE MACHINE UPDATES THE MEMORY OF THE VALVE POSITION.

5. The machine displays "**ACH SPN 2**". Lower the wheel guard to spin the wheel, when the shaft reaches the balancing speed, machine displays "--- **ACH** ---" along with a beep.

6. Once the spin cycle is complete, the display reads "**CAL CUL ACH**" for one second. Machine calculates the results based on the previous two spins.

After calculation the machine displays the unbalance contributions of rim and tire in percentages of total unbalance to allow operator to evaluate the quality of the tire or rim. For example, if the total unbalance is 4.5 oz in which the rim unbalance measured is 3 oz and tire unbalance is 1.5 oz. In this case, the rim unbalance is 67% of total unbalance and tire is 33%. Machine displays "r " " **67**" and "t " " **33**" alternatively until the operator presses the "F" button. This function allows operator to check the unbalance contribution of the rim and tire. If someone has too large unbalance, operator can stop the procedure and change the bad rim or tire.

From this point, there are three possible procedures to conclude the match balance routine. These 3 procedures are quite different depending on the results of calculation.

Procedure 1

The imbalance measured in spin 2 has been reduced to an acceptable amount, less than 2 oz, and it will not be necessary to continue match balance. The display reads "**ACH FIN ISH**" for one second, and then proceeds to the normal two-plane balancing mode and displays the weight imbalance amount and its position for both planes.

Procedure 2

Due to a large amount of remaining imbalance the operator can continue match mount. Machine displays "**CRS CRS R**" and "**TUR TIR ---**" alternatively. This instructs the operator to turn the wheel and make a double cross mark (**XX**) on the right side of the tire at 12 o'clock position when the right center position LED turns to green. See Figure 29.

NOTE: IF YOU DO NOT INTEND TO CONTINUE MINIMIZATION, YOU CAN PRESS THE *CANCEL/STOP* BUTTON

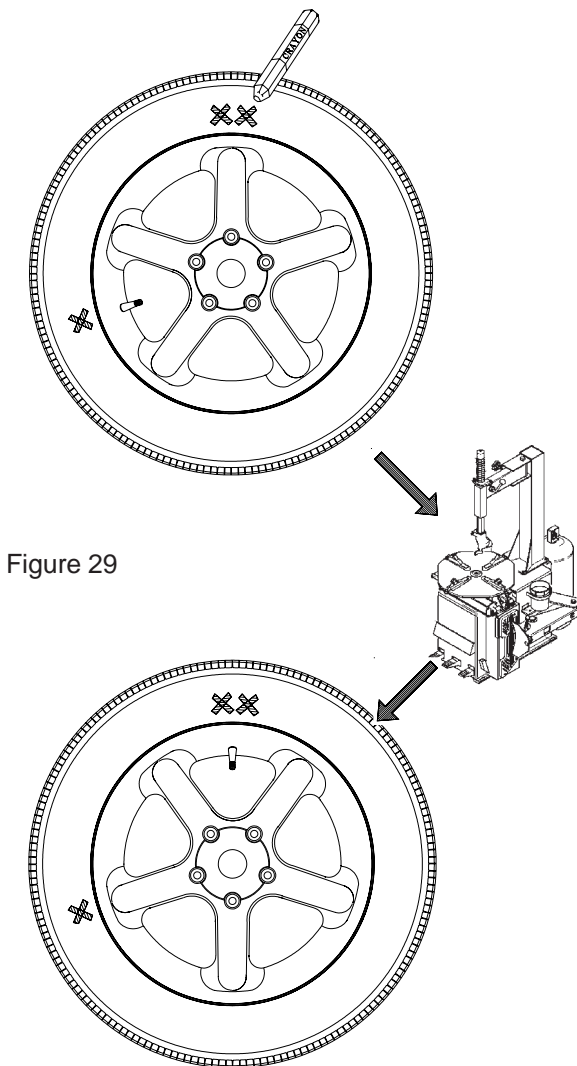

Figure 29

Figure 30

If the Cancel/Stop Button is pressed now, machine displays "**Quit Quit Quit**" for one and half second to remind operator whether he/she wants to quit optimization or not. If one presses Cancel/Stop Button immediately, the program goes to procedure 1. If not, after one and half second, machine returns to the optimization procedure.

To continue with optimization: Deflate the tire and then turn the valve to point the XX mark on the tire. Remount tire/wheel onto shaft, press "F" when ready to continue.

1. The machine displays "**PUT VAL tOP**". Turn the wheel so the valve is at top position. (12 o'clock) and then press F Button. The machine stores the valve position. See Figure 30.

2. The machine displays "**SPN 3**". Lower wheel guard to spin shaft. Machine displays "**ACH SPN 3**".

3. Display will read "--- **ACH** ---" for one second. Balancing results are checked whether or not the matching balancing has been achieved and will display "**ACH CHC** ---" for one second.

4. There are two results that could be given by the previous step:

1 - *Match Balance failure.* Machine displays: "**FAI L**" for one second and then goes to idle state.

2 - *Match Balance is successful.* Machine displays: "**ACH FIN ISH**" for one second and then goes to normal two plane balancing mode. Machine displays the recalculated weights and their position taking the matching results into account.

Procedure 3

1. Machine displays "**CRS CRS L**" and "**FLP tir ---**" alternatively. When the left center position LED turns to green this instructs the operator to turn the wheel and mark a XX on the left side of the tire at 12 o'clock position.

2. If the tire cannot be flipped, press the Cancel/Stop Button to force machine to procedure 2.

Calculations may not allow continuation of the matching process. If this is the case, machine displays "**NO NO NO**" for one and half second. If the operator does not respond the machine returns to above state after one and half second.

If the Cancel/Stop Button is pressed within one and half second, machine will display "**Quit Quit Quit**" for one and half seconds indicating cancelation of optimization returning the machine to normal balancing modes.

If optimization is to be continued with flipping tire, proceed as described below.

3. Deflate the tire then flip, turning the valve to point the XX mark on the tire (as in procedure 2).

4. Inflate the tire and mount it to shaft again. Press the "**F**" Button.

5. The machine displays "**PUT VAL tOP**". Turn the wheel to make valve at top position. (12 o'clock) and then press "F" button. The machine will store the valve position.

6. The machine displays "**SPN 3**".

NOTE: THE F BUTTON CAN BE PRESSED AS OFTEN AS NECESSARY, WITH EVERY PRESS THE MACHINE UPDATES THE MEMORY OF THE VALVE POSITION.

7. Lower the wheel guard to spin the shaft. Machine displays "**ACH SPN 3**" while collecting data. Do not disturb the machine while it is acquiring data.

8. When balancing is complete, the machine displays "--- **ACH** ---" for one second. Machine processes the balancing results to check whether or not the matching balancing has been achieved. Balancing results are checked whether or not the matching balancing has been achieved and will display "**ACH CHC** ---" for one second.

9. There are two results could be given by the previous step.

1. *Matching balancing failure.* Machine displays: "**FAI L**" for one second and then goes to idle state.

2 - *Match Balance is successful.* Machine displays: "**ACH FIN ISH**" for one second and then goes to normal two plane balancing mode. Machine displays the recalculated weights and their position taking the matching results into account.

6.0 OPTIMIZATION ROUTINE- F91

The Optimization Routine is very similar to that of the Match Mount Program (F90). The main difference is that operation begins with a bare rim instead of a rim-tire assembly. Follow instructions as detailed for in chapter 5.0 for F90.

7.0 ALU-S 2-PLANE MODE

This is a mode similar to ALU mode 2 and 3. The difference is that the distance and width parameters are accurately defined for a more exacting weight placement, therefore improving the likelihood of a single spin balance. Follow the procedures below:

1. Press the **Alu-s** button to activate the ALU-S 2-PL mode, the display will read " --- ALU - S 2-PL " when activated. Each depression of the **Alu-s** button will toggle between a 2-plane mode and a single plane mode.
2. Extend the rim offset gauge arm and touch the position of the left weight position. See Figure 31. The display will read "d - 1". The high tone will sound when dimension is entered. Return the gauge arm to the rest position, a low pitch tone will indicate when it is OK to proceed. The width arm is not used in this procedure.
3. Move the parameter arm to the right weight position, the machine displays "d - 2" as the arm is moved. See Figure 32. The high tone will sound when dimensions are entered. Return the gauge arm to the rest position, a low pitch tone will indicate when it is OK to proceed.
4. Lower the wheel guard or press "Enter" to spin the wheel. The display will read "ALU" during the spin cycle.
5. After spinning, The wheel/tire assembly will stop with the outside (right) imbalance plane at top. The display reads both the left and right plane imbalance weight and position.
6. Extend the gauge arm to locate the outer place imbalance. The right display shows the weight amount to be applied, the left display shows the distance the gauge arm has to travel to get to the correction plane. The sape arm will lock when the correct position is reached, at the same time the display will read "0" when the proper position is attained. A "beep" will accompany the lock position. Apply the weight amount indicated using the tape weight applicator mounted on the SAPE extension.

Return the gauge arm to its home position.

7. The left plane correction weight will be applied next as in step 6 above. The steps are:
 - Extend the arm until the arm locks into position.
 - Position the wheel in the weight application position
 - Apply the displayed weight.

NOTE: RETURNING THE GAUGE ARM TO THE

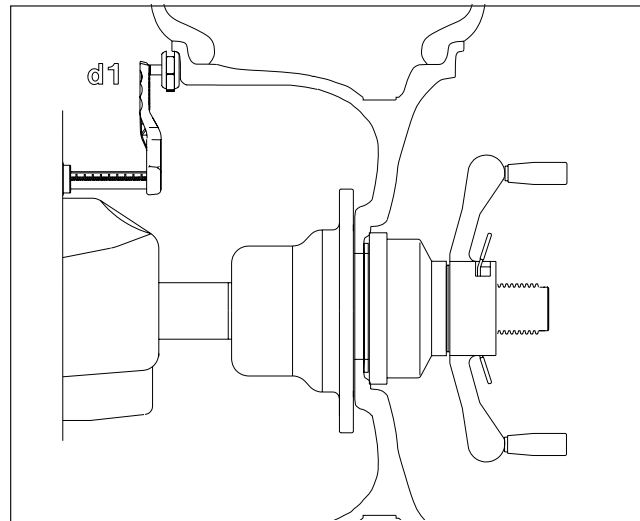

Figure 31

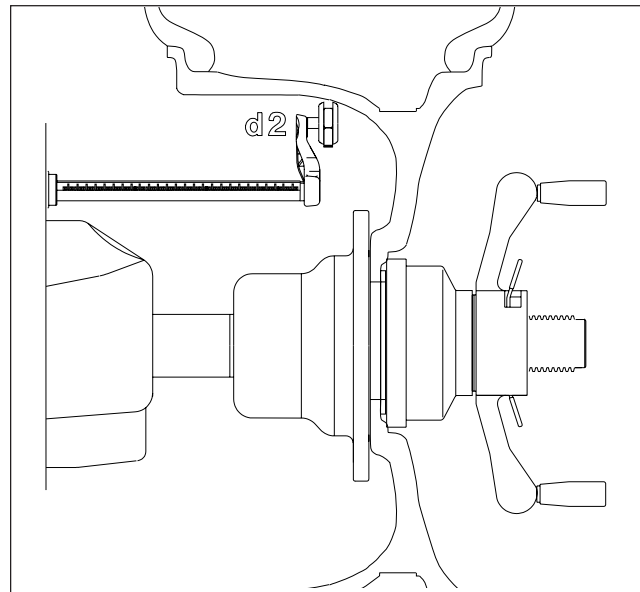

Figure 32

"HOME" POSITION TOGGLES BETWEEN THE LEFT AND RIGHT CORRECTION PLANE.

NOTE: TO EXIT ALU-S MODE AND RETURN TO TWO PLANE DYN (DYNAMIC) MODE PRESS "MODE" BUTTON. THE MACHINE DISPLAYS "ALU OFF" FOR ONE SECOND AND THEN ENTERS IDLE STATE IN THE 2-PL DYN MODE

NOTE: INSPECT THE RIM AND AVAILABLE WEIGHTS AND USE GOOD JUDGEMENT IN YOUR SELECTION. WEIGHTS SHOULD NOT INTERFERE WITH ANY SUSPENSION PARTS OR MAKE CONTACT DURING ROTATION. IF A WEIGHT DOES MAKE CONTACT, USE AN ALTERNATE LOCATION AND SELECT AN APPROPRIATE MODE.

7.1 ALU-S SINGLE-PLANE (STATIC)MODE

This is a mode similar to a conventional Static mode. The difference is that the distance and diameter parameters are accurately defined for a more exacting weight placement, therefore improving the likelihood of a single spin balance. Follow the procedures below:

1. Press the **Alu-s** button to activate the ALU-S 1-PL mode, the display will read " --- ALU - S 1-PL" when activated. Each depression of the **Alu-s** button will toggle between a 2-plane mode and a single plane mode.
2. Extend the rim offset gauge arm and touch the position of the desired single weight position. See Figure 33. The display will read "**d - I**". A tone will sound when dimension is entered. Return the gauge arm to the home rest position, a low pitch tone will indicate when it is OK to proceed.

NOTE: *The width arm is not used in this procedure.*

3. Lower the wheel guard or press "**Enter**" to spin the wheel. The display will read "**ALU 1 PL**" during the spin cycle.
4. After spinning, The wheel/tire assembly will stop with the imbalance plane at top. The display reads both the imbalance weight and position.
5. Extend the gauge arm to locate the place of imbalance. The right display shows the weight amount to be applied, the left display shows the distance the gauge arm has to travel to get to the correction plane. The sape arm will lock when the correct distance position is reached, at the same time the display will read "**0**" when the proper position is attained. A "beep" will accompany the lock position. Apply the weight amount indicated using the tape weight applicator mounted on the SAPE extension.
6. Perform a check spin if desired

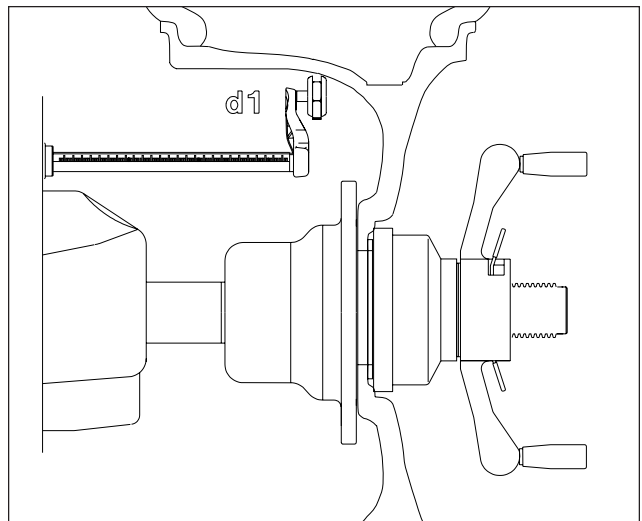

Figure 33

NOTE: TO EXIT ANY ALU-S MODE AND RETURN TO TWO PLANE DYN (DYNAMIC) MODE PRESS "MODE" BUTTON. THE MACHINE DISPLAYS "**ALU OFF**" FOR ONE SECOND AND THEN ENTERS IDLE STATE IN THE 2-PL DYN MODE

NOTE: INSPECT THE RIM AND AVAILABLE WEIGHTS AND USE GOOD JUDGEMENT IN YOUR SELECTION. WEIGHTS SHOULD NOT INTERFERE WITH ANY SUSPENSION PARTS OR MAKE CONTACT DURING ROTATION. IF A WEIGHT DOES MAKE CONTACT, USE AN ALTERNATE LOCATION AND SELECT AN APPROPRIATE MODE.

8.0 SPOKE BALANCING MODE

A standard dynamic balance places compensation weight in two planes, inner and outer, at the top dead center 180 degrees of each plane of calculated imbalance. Sometimes the outside weight placement may be unsightly on a custom wheel. See Figure 34.

The Spoke Mode is designed to “hide” outer plane corrective weight by placing the required weight behind selected spokes in order to retain the esthetic appeal of the wheel.

1. Press the Alu-s/Spoke button until “**SPO**” is displayed, the display will read “**SPO**” when activated.
2. Enter left plane distance using the SAPE as you would a dynamic 2-plane or ALU-S balance.
3. When machine displays “**d - 2**” move the SAPE arm to the right position plane where weight will be placed.
4. Press Enter, or, lower hood guard. The display will read “**SPO**” while spinning. After Braking to a stop rotate the shaft to the **inside** plane top dead center position indicated by the center green LED. Extend the SAPE until the right reading says “**0**”, place indicated weight in the position directed by the SAPE.
5. Rotate the wheel to the **outside** plane top dead center position indicated by the center green LED, press the “**F**” button to indicate top dead center.

NOTE: Mark the tire to assist in referencing the corrective weight top dead center.

6. The display will read “**SPO 1**”. Locate the first spoke nearest to top dead center and rotate the wheel so that spoke is at top dead center. See Figure 34. Press **F** to store first position.
7. The display will read “**SPO 2**”. Locate the second closest spoke to top dead center and rotate the wheel to the top dead center position, press **F** Button again to store the position. See Figure 35.
8. The display will read “**P -2**” on its left window and the balance weight amount in right window. Place the weight amount displayed at “position 2” behind the spoke, then rotate the wheel to locate position 1. See Figure 36.
9. When position 1 is located, the balancer will beep. The display will read “**P -1**” in the left window and the weight amount on right window. Place the weight amount displayed at “position 1” behind the spoke.
10. Perform a check spin if desired.

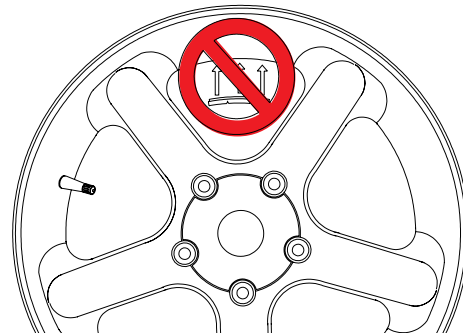

Figure 34

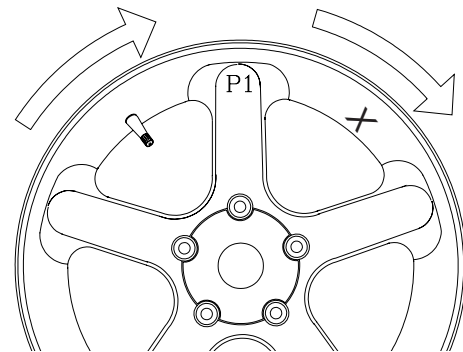

Figure 35

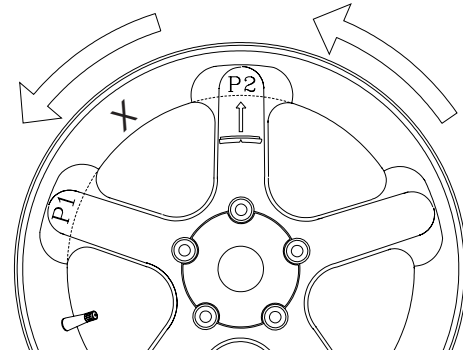

Figure 36

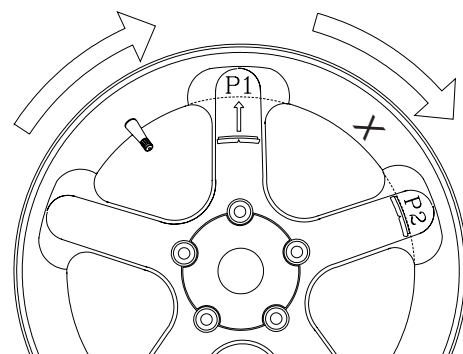

Figure 37

9.0 SPLIT WEIGHTS - P92

The "Split Weight" function is used to split one large weight to two smaller weights with 60% of original weight and 33.6° away each direction from the original position. For instance, if the original unbalance weight is 3 oz, the weight is split into two 1.75 oz weights and placed 56.4° and 123.6° from the original larger value located top dead center at 90 degrees. The minimum weight to activate this function is 2 oz. The procedure is described below. See Figure 38.

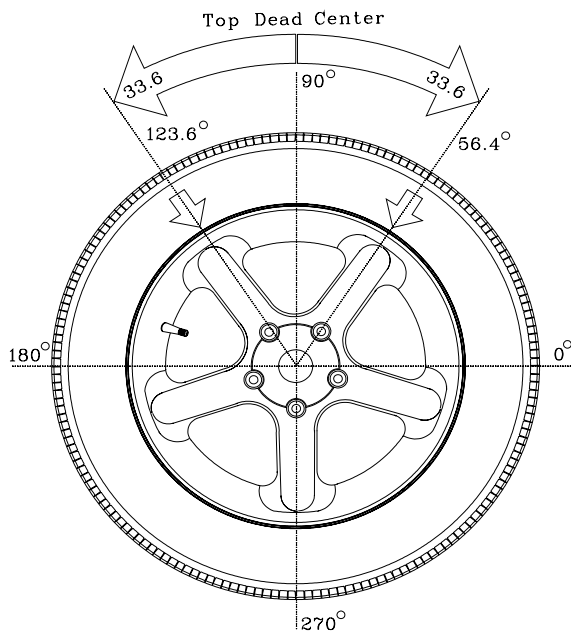

Figure 38

1. After balancing, the weight amounts are displayed in left and right windows.
2. Enter **F92**, machine will display "**SPL -L-**" or "**SPL -R-**" meaning which plane should be split.
3. Press the "**STOP**" button alternately to toggle between the left and right plane.
4. Once the desired plane is chosen, press the "F" button. The machine splits the weight into two parts. The split weight is 60% of the original weight. The position is 33.6° from each side the original position.
5. If the displayed weight is less than 2 oz (56.7 grams), the machine will display "**NOT AVL**" for one second, and then resumes the normal display.
6. Pressing "**STOP**" cancels the split weight mode and operation returns to normal. The operator can check if the position of original weight is between the two smaller weights.
7. Pressing the "**STOP**" button again, returns the machine to idle mode without weight amount or position display.
8. For a check spin, lower the hood guard or press "**SPIN**" button.

10.0 USER CALIBRATION

F14 Shaft Calibration

The VPI System III Balancer features a user calibration program which requires only a few minutes to complete. Perform this procedure when the balancer has been moved, disturbed, or whenever accuracy is questioned. Occasional field calibration will ensure years of reliable service.

Follow these 3 simple steps for shaft calibration:

1. Activate Calibration.

Press the **F** Button then press the UP/Down buttons (Figure 39) until the display reads "F" "14", press **ENTER**

- Once F14 activates, the display will read "CAL" "GAN" for one second.
- The display will then read "SPN" "1".

2. Spin bare shaft

Lower the wheel guard or press **ENTER** to spin the shaft. See Figure 40.

- Displays "CAL" "1" as the machine is collecting data and performing calculations. After taking data, the shaft is automatically braked to a stopped.
- The display will read "SPN" "2".

3. Spin shaft with calibration slug on the left side.

Mount calibration slug to inside edge of shaft mounting plate as shown in Figure 41.

- Lower the wheel guard or press **ENTER** to spin the shaft with slug.
- Displays "CAL" "2" as the balancer is doing its calculations. When complete, the shaft is automatically braked to a stop.
- The display will read "CAL" "FIN" for one second when this step of calibration is **FIN**ished.
- If for some reason the calibration detected an error, the display will read: "Err" "C__" after the shaft brakes.

NOTE: THE BALANCER WILL NOT FUNCTION UNTIL A VALID CALIBRATION HAS BEEN PERFORMED. AN ERROR MESSAGE WILL BE DISPLAYED IN THE EVENT PROBLEMS OCCUR DURING THE CALIBRATION PROCESS.

SHAFT CALIBRATION IS COMPLETE
Continue to next page for parameter arm calibration instructions.

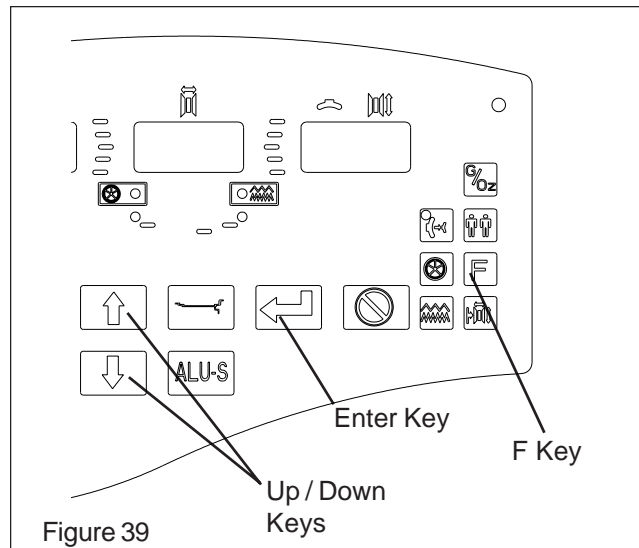

Figure 39

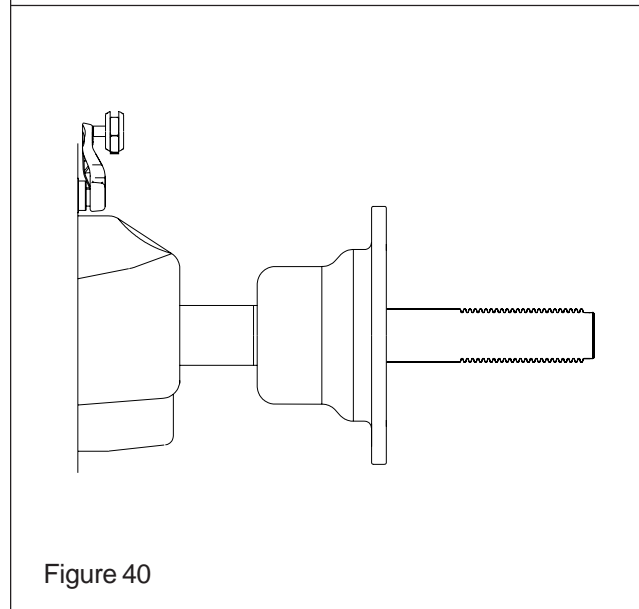

Figure 40

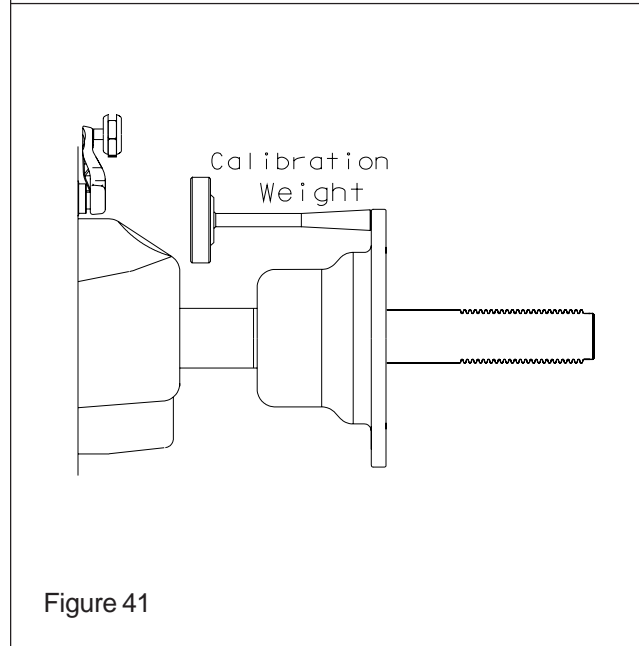

Figure 41

11.0 WIDTH PARAMETER CALIBRATION

F79 Calibration of Width SAPE only

1. Press and release the “F” key toggle the “UP / DOWN” arrow keys until “F” “79” is displayed and press enter to activate function of F79. Once activated the display will change to “CAL” “SAP” “E-2” for 1 second, then the display will change to “DIS” “tO” “FLA”.
2. Pull the distance gage to the outside flange of the backing collar, use the flat head of the calibration weight as an index. After a short beep, the machine displays “bAC H POS”. Return the arm to the rest position. See Figure 42.
3. The display will read “to FLA NGE”, Touch the tip of the width gauge to the backing collar and hold it for one second or press the “F” button (Figure 42a). The display will change to “bAC “H’ “POS” followed by a tone. Return the SAPE arm to the home position.
4. Display will then change to “tO” “CAL” “SLG”. Screw the calibration weight onto the outside of the flange. Touch the tip of the width gauge to the tip of the calibration slug and hold it for one second or press the “F” button (Figure 43). The display will change to “SAP” “E-2” “FIN” for one second followed by a tone indicating a successful calibration. Unit will then go into an idle state.

WIDTH SAPE CALIBRATION COMPLETE

11.1 PARAMETER CALIBRATION

F80 Distance, Diameter and Width SAPE Calibration

1. Make sure the SAPE arm is in the home position as shown in (Figure 44).

NOTE: WEIGHT TRAY MUST BE INSTALLED

2. Activate the gauge calibration program. Press and release the F key and toggle the “UP / DOWN” button until 80 is displayed on right display window and press enter.
3. The right display will read "CAL" “3-D” “SAP" for one second (Do not move the arm at this point) this means CALibration SAPE. Then it displays "SAP" “OUT” “FUL”. The SAPE calibration procedure is activated.

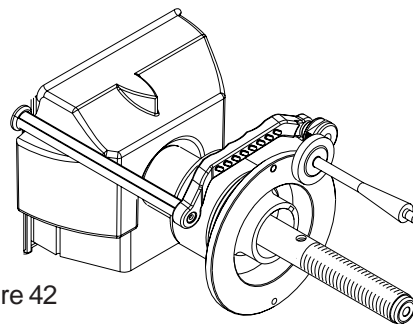

Figure 42

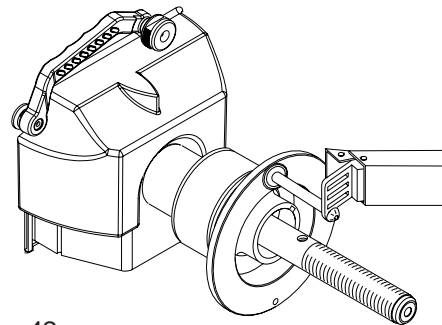

Figure 42a

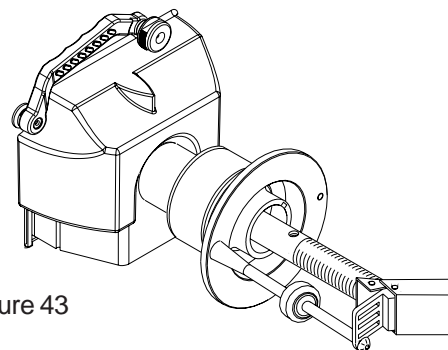

Figure 43

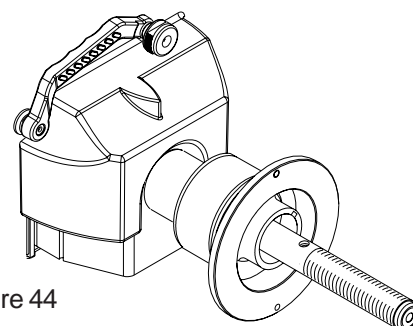

Figure 44

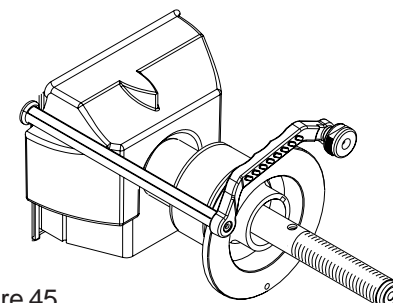

Figure 45

4. Gently pull the **SAPE** arm **OUT** until it is **FULLY** extended, (Figure 45) hold it steady for about 1 second, a tone will sound.

5. Display will read "**BAC**" "**H**" "**POS**" followed by a beep. Return the arm to the home position. Fig. 44.

6. Display changes to "**dIA**" "**-18**" "**POS**".

7. Gently pull the SAPE out and rest the arm of the SAPE gauge on the inner part of the bell housing as shown in (Figure 46). A tone will sound and the display will change to "**BAC**" "**H**" "**POS**".

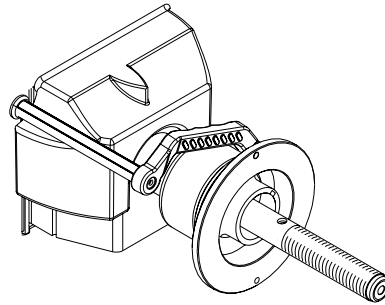

Figure 46

8. Return the arm to the home position, Figure 44. The display will change to "**dIA**" "**42.1**" "**POS**".

9. Locate the Calibration Weight. Place the calibration weight with the large end oriented on the bell collar as shown in Figure 47. Extend the SAPE arm outward and rotate the extension to just touch the end of the calibration weight as shown in Figure 47. A tone will sound and the display will change to "**BAC**" "**H**" "**POS**". Return the SAPE arm to the home position.

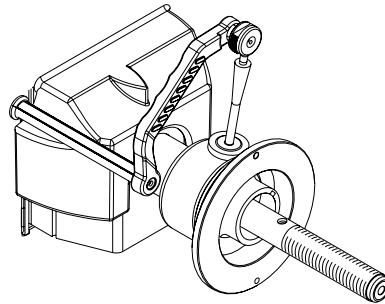

Figure 47

10. The display will change to "**SAP**" "**E-1**" "**FIN**" for one second then changes to "**DIS**" "**tO**" "**FLA**".

11. Pull the distance gage to the outside flange of the backing collar, use the flat head of the calibration weight as an index. After a short beep, the machine displays "**bAC H POS**". See Figure 47a.

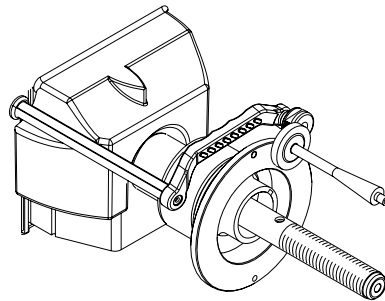

Figure 47a

12. Touch the tip of the *width* gauge to the backing collar and hold it for one second or press the "**F**" button (Figure 48). The display will change to "**bAC**" "**H**" "**POS**" followed by a tone. Return the SAPE arm to the home position.

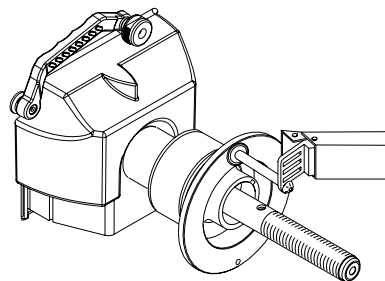

Figure 48

13. Display will then change to "**tO**" "**CAL**" "**SLG**". Screw the calibration weight onto the outside of the flange. Touch the tip of the width gauge to the tip of the calibration slug and hold it for one second or press the "**F**" button (Figure 49). The display will change to "**SAP**" "**E-2**" "**FIN**" for one second followed by a tone indicating a successful calibration. Unit will then go into an idle state.

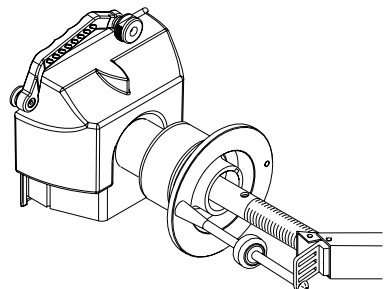

Figure 49

FULL SAPE CALIBRATION COMPLETE

12.0 EXPLANATION OF PROGRAM CODES

Various functions and features can be programmed to enhance operation. These programs are referred to as “F Codes”. Activate the “F Code” programs by pressing and holding the **F Button** while depressing the up/down arrow buttons or by turning the shaft until the desired number is displayed on the right display window. User Codes are explained as follows:

- F1 Toggle between normal and fine mode.
- F3 Toggle switch between gram and ounce display
- F4 Calibrate with adapter unbalance
- F7 Toggle switch of millimeter and inch for diameter measurement
- F12 The balancer has 4 counters that keeps track of total number of cycles for a certain parameter. The balancer will automatically cycle through the counters after F12 is pressed. The order of the counters are:
 1. Display “**Ctr ALL**” for one second.
Counter number of all spins.
 2. Display “**Ctr CAL**” for one second.
Counter number of spins since last calibration.
 3. Display “**Ctr SrV**” for one second.
Counter number of service spins.
 4. Display “**Ctr USR**” for one second.
Counter number of user spins.
- F14 Shaft User Calibration by user
- F18 ALU-S 2-plane mode (press balancing mode button to exit and back to DYN mode)
- F19 ALU-S 1-plane (static)mode (press balancing mode button to exit and back to DYN mode)
- F43 Read or reset operator counters, reads or allows reset of all four operators. (A, B, C, D)

- F44 Read or reset productivity of user. Display counter number of default user only.
- F53 Display test
- F79 Calibration of the width SAPE.
- F80 Calibration of Distance and Diameter SAPE
- F90 Tire Matching Mode
- F91 Optimization

13.0 MAINTENANCE

WARNING!

BEFORE ANY MAINTENANCE OR REPAIRS ARE ATTEMPTED THE MACHINE MUST BE DISCONNECTED FROM THE ELECTRIC SUPPLY.

This balancer does not require any special maintenance, but the following precautions are required:

- A.** Periodically wash all plastic parts with a glass cleaner. Wipe with a dry cloth.
- B.** Clean all adapters regularly with a nonflammable liquid detergent all. Lubricate with a thin layer of oil.
- C.** Periodically perform a routine calibration as outlined on pages 22, 23 and 244 of this manual.

14.0 TROUBLE SHOOTING

<u>TROUBLE</u>	<u>CAUSE</u>	<u>REMEDY</u>
When turning the machine on, the displays do not light	No electric power Defect in the electric/electronic system	Check the input voltage Call the Equiserv service center for assistance
The machine gives random readouts.	Machine unstable on the floor Water in the tire Loose adaptor Defective electronic board	Check that machine is stable Remove water from tire. Tighten the adaptor firmly Call the Equiserv service center for assistance
The machine does not stop after balancing cycle	Defective electronic component	Stop using the machine immediately and call the Equiserv service center for assistance
The balancer is slow to display when powering machine up.	This machine performs a self-test routine on start-up. There will be a delay of several seconds before the display is activated.	This is a normal characteristic of the machine
If the parameter arm(s) ceases to properly measure values causing machine lockup.	Malfunction of the Parameter arm(s) from either a failure of the electrical system or harness connection failure.	Replace the Parameter arm(s) or manually enter the parameters to continue operation.



USA

Equipment Services

309 Exchange Avenue
Conway, Arkansas 72032
Tel.: (800) 362-8326 or (501) 450-1500
Fax: (501) 450-1585

CANADA

6500 Millcreek Drive
Mississauga, Ontario
Canada L5N 2W6
Tel: (905) 814-0114
Fax: (905) 814-0110

FRANCE

Snap-On Equipment France
Z.A. Du Vert Galant
15, rue de la Guivernone
BP 7175
95310 Saint Ouen L'Aumone
Tel: (33) 1-3448-5878
Fax: (33) 1-3448-5879

JBC GERMANY

Geschäftsbereich der Snap-on Equipment GmbH
Werner-von-Siemens-Str. 2
D-63419 Pfungstadt
Deutschland
Tel: +49 (0) 6157 12 600
Fax: +49 (0) 6157 12 601
Website: www.johnbean.de

UNITED KINGDOM

Snap-On Equipment Ltd.
John Bean Equipment Group
Oldmedow Road
Kings Lynn
Norfolk
PE30 4JW

LATIN AMERICA

Snap-on Tools International, Ltd.
2801 80th Street
Kenosha, WI 53143
Tel: (262) 656-5003
Fax: (414) 656-1403

Notice: The information contained in this document is subject to change without notice. **Equipment Services** makes no warranty with regard to this material. **Equipment Services** shall not be liable for errors contained herein or for incidental consequential damages in connection with furnishings, performance, or use of this material.

This document contains proprietary information which is protected by copyright and patents. All rights are reserved. No part of this document may be photocopied, reproduced, or translated without prior written consent of **John Bean**.



is a trademark of Equipment Services and Snap-on Incorporated