

John Bean

VPI SYSTEM III

WHEEL BALANCER



EEWB502PD



EEWB502D

Parts Manual

All information contained or disclosed in this document is considered confidential and proprietary by Snap-on Equipment. All manufacturing, use, reproduction, and sales rights are reserved by Snap-on Tools Company and the information contained herein shall not be used in whole or in part without the express written consent of Snap-on Equipment.

Table of Contents

BALANCER ASSEMBLY	2
PEDAL ASSEMBLY POWER CLAMP	2
2D SAPE ASSEMBLY	4
VIBRATORY ASSEMBLY (POWER CLAMP)	6
VIBRATORY ASSEMBLY	7
CONES AND ACCESSORIES	8
UPPER DISPLAY	9
WHEEL GUARD AND 3D SAPE	10
BOM	11

BALANCER ASSEMBLY

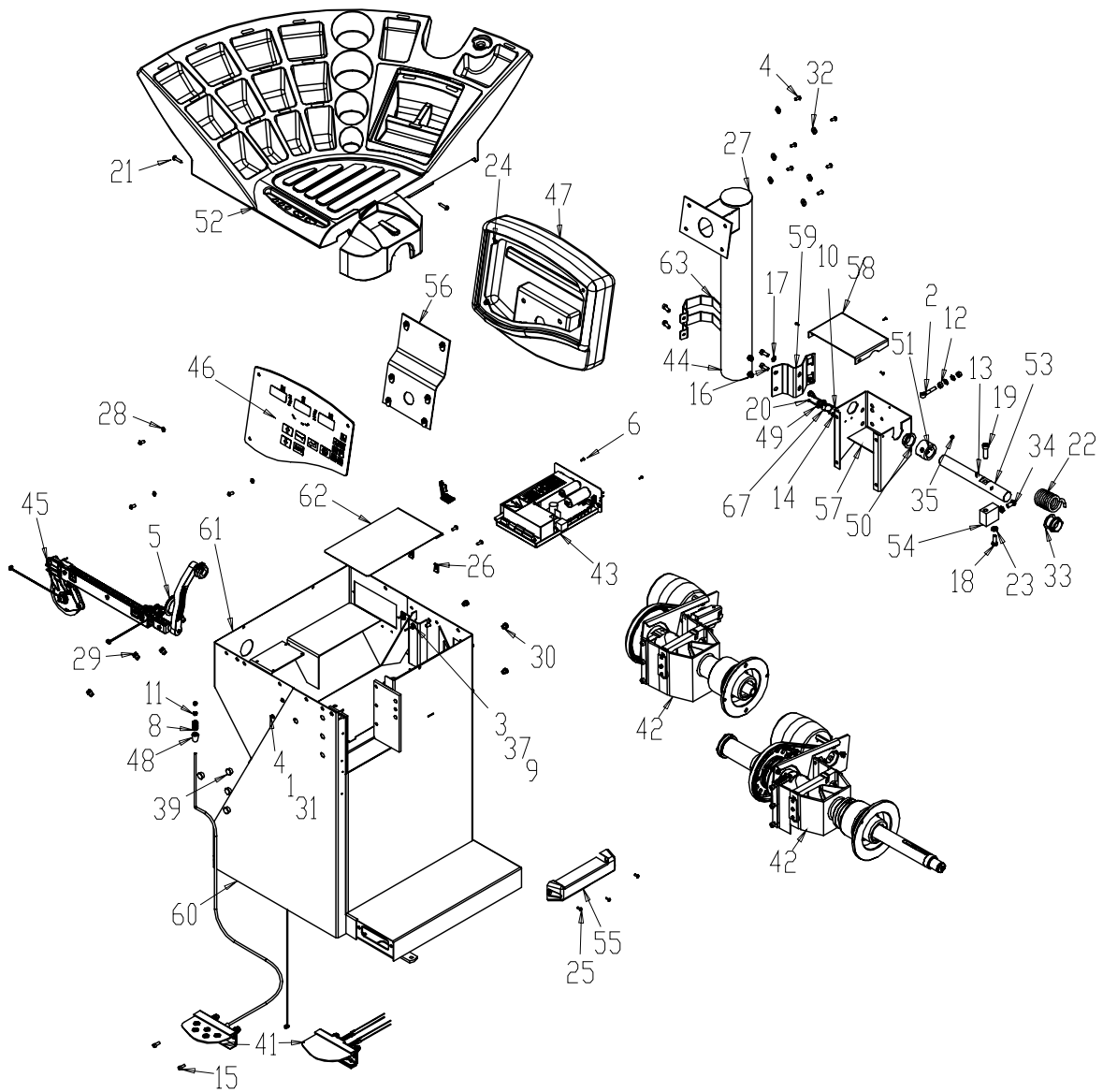

PEDAL ASSEMBLY POWER CLAMP

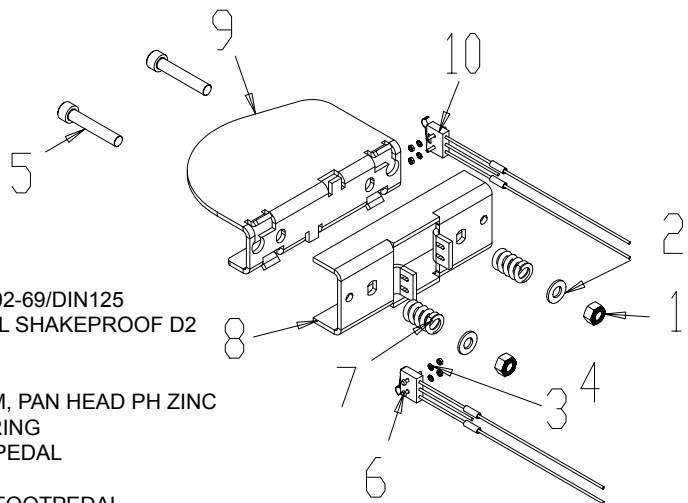

SYM	REQD	PART NO	DESCRIPTION
1	2	1-10033	NUT, HEX, M8
2	2	1-10041	WASHER D.8 UNI6592-69/DIN125
3	4	1-1048	WASHER, EXTERNAL SHAKEPROOF D2
4	4	1-11033	NUT - HEX, M2
5	2	1-18209	SHCS-M8 X 45
6	4	1-36606A	SCREW - M2 X 16MM, PAN HEAD PH ZINC
7	2	1-6668	COMPRESSION SPRING
8	1	EAS2113J93A	SUPPORT - BRAKE PEDAL
9	1	EAS2113J94A	FOOT PEDAL
10	2	EAW0233J46A	SWITCH ASSY - PC FOOTPEDAL

SYM	REQ	PART NO	DESCRIPTION
1	4	01101609000	NUT-STOP 1/4-20 UNC-2B CAD
2	1	1-01530	EYEBOLT-M8 X 50
3	1	1-1548	WASHER-EXT,SHAKEPROOF 6MM
4	15	1-2509	SCREW-BHCS, 1/4 - 20 X 5/8
5	1	1-2676	PLUG-HOLE, 2"DIA
6	5	1-3724	SCREW-SELF TAP,5 X 10MM
8	1	1-6668	COMPRESSION SPRING
9	1	1-7558	POP RIVET-3/16"
10	2	1-9541	WASHER-FLAT,M3 DIN 125A
11	2	1-11633	NUT-M6 X 5,2MMTHK, BLK
12	2	1-11833	NUT - M8 - X 1.25 DIN 934
13	1	1-12452	PINS - STRAIGHT SLOTTED 8X45
14	2	1-15033	NUT-KEPS, M3 - .5
15	2	1-16309	SCREW - SHCS, M6 X 16MM,
16	8	1-17709	SCREW - SHCS M8 X 20MM
17	8	1-17741	WASHER, 8MM DIN125A
18	1	1-19109	SHCS - M10 X 25MM
19	1	1-20409	SCREW TCEI M12X35 12.9 BR
20	2	1-27001	SCREW,HEX HEAD MAC. M3X25 8.8
21	3	1-03725A	SCREW-PH SELF TAP M6.3X32 PHI
22	1	1-04267A	SPRING-TORSION
23	2	1-04634A	NUT - HEX, M10, 1,5MM PITCH,
24	3	1-07039A	NUT-TINNERMAN,1/4-20, 150 THK
25	3	1-07424A	SCREW - PAN HD, 8-18 X 1/2
26	2	1-07439A	NUT - SPEED, "U" TYPE,
27	1	1-10276A	PLUG - HOLE, BLACK 3.35IN - 3.40IN
28	3	1-11744A	WASHER - NYLON FLAT
29	4	1-17659A	NUTSERT - M10
30	8	1-18359A	NUTSERT, M8
31	4	1-20041A	WASHER - FLAT 18MM OD X 6.5MM ID X 1.5MM THK
32	6	1-20141A	WASHER, FLAT- 1/4
33	1	1-22441A	SHIM RING 32X45X1
34	1	1-47709A	SHCS - M10 X 20MM
35	1	1-49010A	SCREW, SOCKET WITH CUP POINT M8X8 45H A2
36	4	2-3657	CABLE CLAMP- FLAT CABLE
37	1	2-23201	TERMINAL LUG-6.3MM X .8MM POP
38	1	5-06745A	WRAP - SPLIT HARNESS
39	4	8-7216	PLUG-HOLE, 16MM DIA
40	2	8-09619A	STRAIN RELIEF - FLAT CABLE
41	1	EAA0263G07A	ASSY-BRAKE PEDAL
		EAA0346J82A	ASSY-BRAKE POWER CLAMP
42	1	EAA0338G36A	VIBR. MOT. UL IF40/28.5
		EAA0344G06A	VIBR. "P" OPTIMA
43	1	EAA0338G83B	ASSY - IBP DIGITAL BOX
44	1	EAA0346J60A	ASSY - JB VPI SYS III TOWER
45	1	EAA0346J73A	ASSY - SAPE, 1D-2D W/ AUTO ST
46	1	EAA0346J92A	ASSY - DISPLAY JB VPI SYS III
47	1	EAC0053J05A	HOUSING-DISPLAY, L1
48	1	EAC0053J15A	BRAKE SPACER
49	1	EAC0053J16A	MICROSWITCH PLATE
50	2	EAC0058D36A	WHEELGUARD BUSHING D.32
51	1	EAC0058D38A	SCHALTRING SWITCH SEGMENT
52	1	EAC0054P11A	BALCO WEIGHT-TRAY
53	1	EAM0021D02A	SHAFT - WHEEL GUARD M1
54	1	EAM0021D39A	STOP PLATE 25MM
55	1	EAM0062G50A	VIBRATORY SYSTEM COVER
56	1	EAS2021J42A	PLATE - INNER, DISPLAY, L1
57	1	EAS2103J53A	BACKPACK - M2 CABINET
58	1	EAS2103J54A	COVER - M2 BACKPACK
59	1	EAS2103J58A	PLATE -TOWER BRACKET
60	1	EAS2113J02A	CABINET - M2 US, RED RAL 3000
61	1	EAS2113J27A	COVER - REAR, M2 CABINET
62	1	EAS2113J53A	SHIELD - FIRE
63	2	EAS2113J54A	CLAMP - BALANCER TOWER
66	1	EAW0233J04A	CABLE - JBC DISPLAY
67	1	EAW0233J08A	CABLE-SWITCH ASSY
68	1	EAW0233J47A	CABLE - 3D SAPE EXTENSION

2D SAPE ASSEMBLY

EAA0346J73A

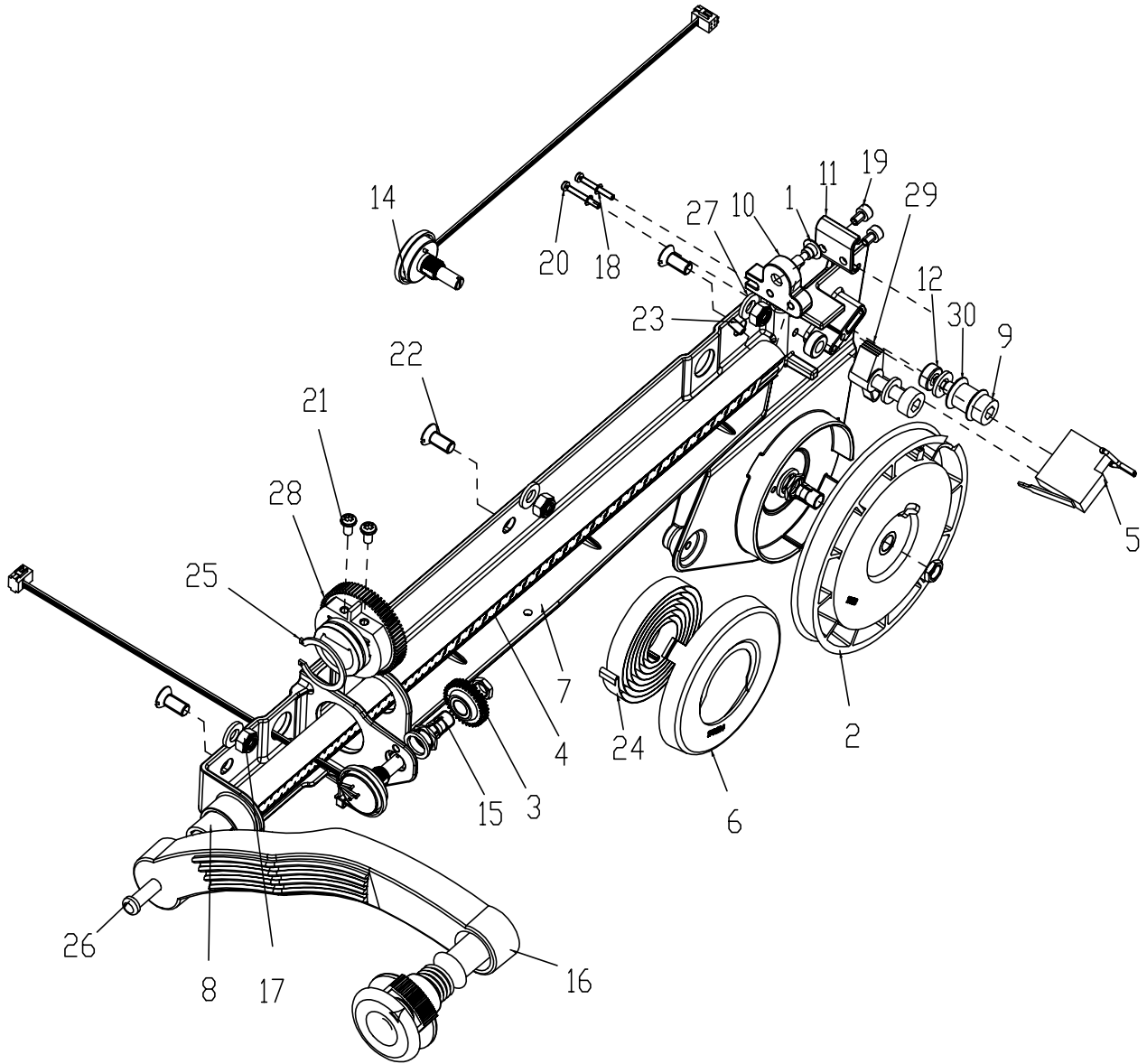

SYM	REQD	PART NO	DESCRIPTION
1	3	1-27903A	SCREW - M6 X 14MM FHMS, SKT DIN 7991
2	1	1-03967A	SPRING-SAPE AUTO STOP SYSTEM
3	3	1-25433A	NUT-M6 KEPS, SERRATED LW ZINC
4	2	1-11726A	SCREW, SELF TAPPING FOR PLASTIC
5	1	1-13377A	CIRCLIP-27MM X 1.20MM DIN 471
7	2	1-17223A	SHEETMETAL SCREW PHIL HEAD
8	2	1-20341A	WASHER, PLAIN A 2,7-ST- A2J UNI6592 DIN
9	1	1-3824	SCREW-SELF TAP,6 X 12MM
10	2	1-3924	SCREW-PHMS, M4.8 X 8MM SELF TAP
11	2	1-5904	SCREW FIL HD M 2.5 X 20MM DIN 84
12	3	1-9841	WASHER PLAIN, 6MM
13	2	2-07657A	CLAMPING DEVICE W/NUT
14	1	2-09437A	CUTOUT BLADE RELAY 3VDC, 3.8W, TRACTIVE
15	1	8-1940	PIN-PUSHIN,NYLON, .165 X 1.062
16	2	EAA0266D20A	ROTATIVE TRANSDUCER 100HM
17	1	EAA0277D94A	SAPE ARM EUROPE W/ EJECTOR
18	1	EAC0058D06A	RIEMENHALTEROLLE MIT EINLEGETEIL
19	1	EAC0058D12A	COG WHEEL - 56 TOOTH
20	1	EAC0058D13A	COG WHEEL 28 TEETH
21	1	EAC0058D29A	GEARTOOTH
22	1	EAC0058D58A	FEDER-SICHERUNGSDECKEL SAFETY COVER
23	1	EAC0087G60A	M1 SAPE SUPPORT
24	3	EAC0094G24A	STANDARD. SAPE A.S.S. SPACER
25	1	EAL0349G31A	DISTANCE SCALE
26	1	EAM0005D35A	REEL-GUIDING,SAPE
27	2	EAM0005D60A	SMALL GUIDE
28	3	EAM0053G15A	STANDARD. ROLL PIN A.S.S
29	1	EAM0053G17A	STANDARD. ROD SAPE, M1
30	1	EAM0055G94A	STAND. SAPE A.S.S. TOOTHED BELT
31	1	EAS2113J89A	BRACKET - SAPE BELT WHEEL
32	1	EAS2113J90A	BRACKET-SAPE BELT HOLDER

VIBRATORY ASSEMBLY (POWER CLAMP)

EAA0363G57A

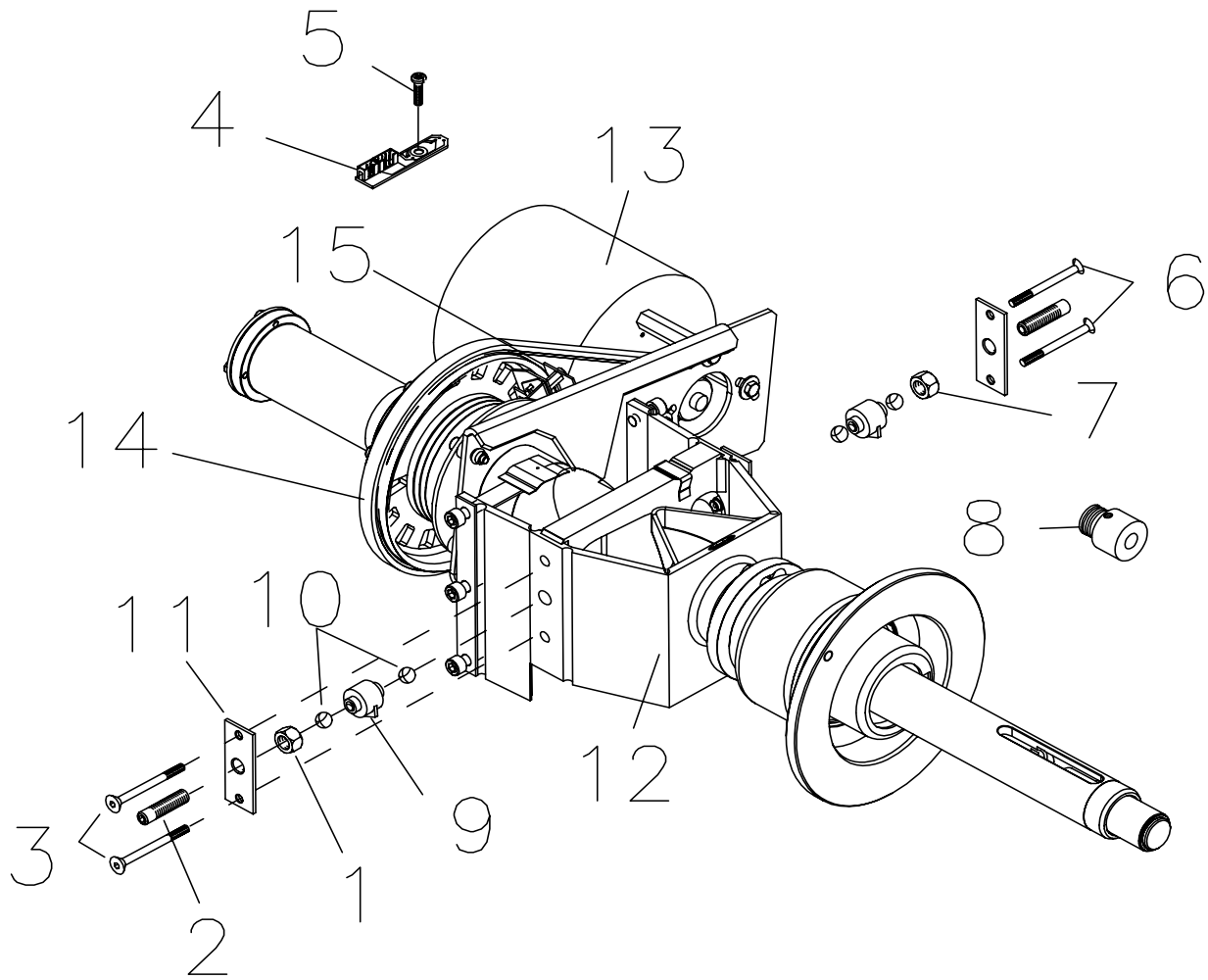

REF	QTY	PART NUMBER	DESCRIPTION
1	1	1-11833	NUT-HEX M 10 X 1 DIN 934
2	2	EAM0005D07A	SETSCREW - HEX SOCKET M 10 X 1
3	2	1-19903A	SCREW HEX SOCKET / COUNTERSUNK M 4 X 65
4	1	EAA0344G00A	ENCODER PCB
5	1	1-13004	SCREW PHILLIP PAN HD M 4 X 6
6	2	1-17403	SCREW HEX SOCKET / COUNTERSUNK M 4 X 25
7	1	1-4034	NUT - HEX M 10 X 1 DIN 439
8	1	EAM0005D08A	PULLEY SMALL
9	1	EAA0260D59A	TRANSDUCER
10	4	8-1144	BALL, STEEL
11	2	1-2967	PRETENSION SPRING
12	1	EAA0344G06A	VIBRATOR ASS'Y-MOTORIZED
13	1	EAA0266D29A	MOTOR 230V/50-60HZ
14	1	8-3531	MULTIRIB BELT 5 PJ 711 DIN 7867
15	1	EAP0201D20A	POWER CLAMP ENCODER
*	1	EAW0239D00A	RIBBON CABLE VIBRATORY

VIBRATORY ASSEMBLY

EAA0364G85A

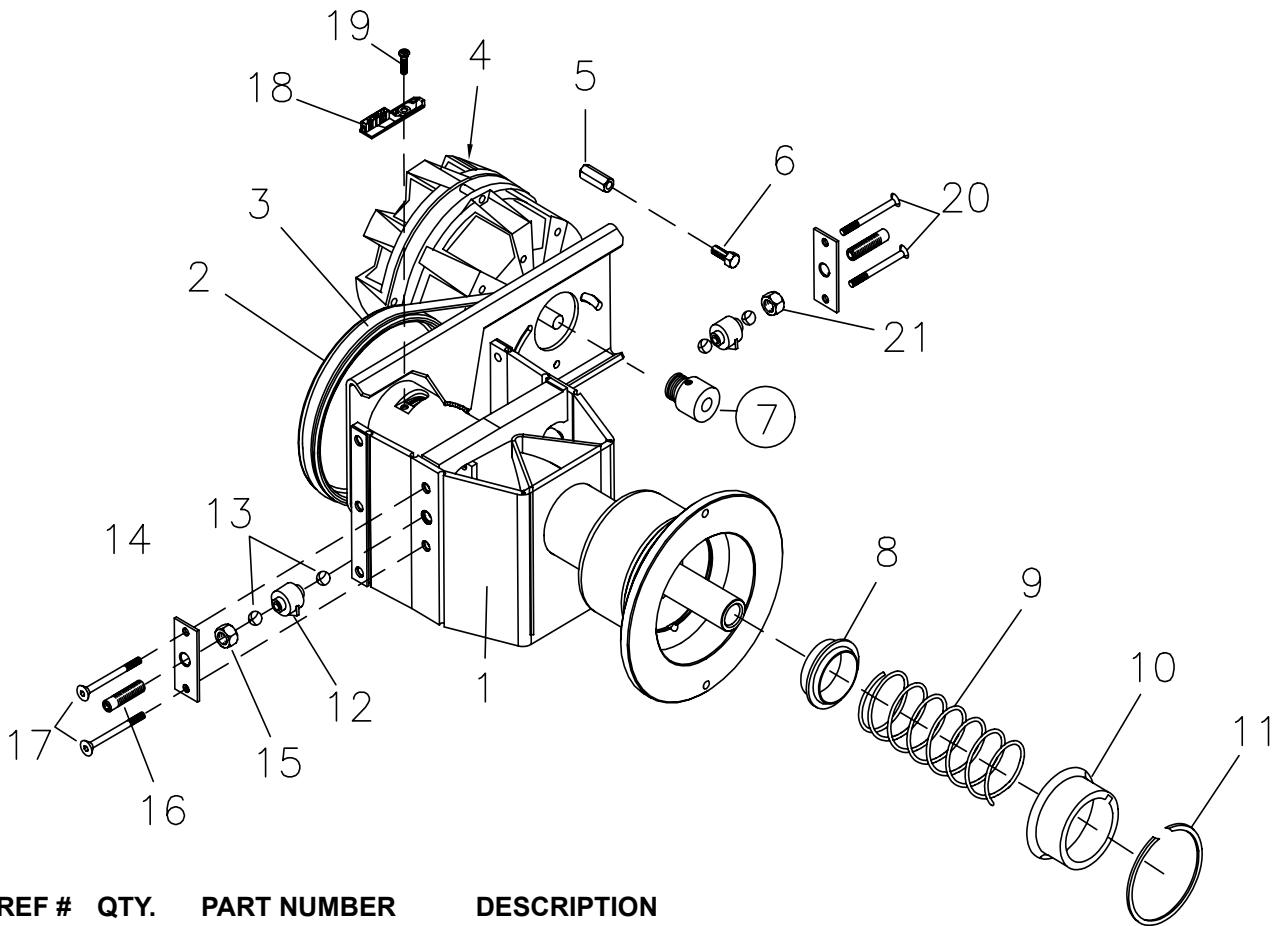

REF #	QTY.	PART NUMBER	DESCRIPTION
1	1	EAA0364G85A	VIBRATOR ASS'Y-MOTORIZED
2	1	EAM0005D12A	DRIVE WHEEL
3	1	8-3531	MULTIRIB BELT 5 PJ 711 DIN 7867
4	1	EAA0266D29A	MOTOR, AC 120W 1 PH 220-240V - 50/60 HZ
5	2	EAM0005D09A	MOTOR DISTANCE BOLT
6	1	1-30701	SCREW HEX HD M 6 X 12
7	1	EAM0005D08A	MOTOR PULLEY
8	1	EAC0058D03A	SPRING CENTERING RING
9	1	1-6498	SPRING - COMPRESSION 5 X 63 X 120
10	1	EAS2025D14A	SPRING CASE DEEP DRAW
11	1	1-13077	SNAP RING
12	1	EAA0260D59A	TRANSDUCER
13	4	8-1144	BALL, STEEL
14	2	1-2967	PRETENSION SPRING
15	1	1-11833	NUT-HEX M 10 X 1 DIN 934
16	2	EAM0005D07A	SETSCREW - HEX SOCKET M 10 X 1
17	2	1-19903A	SCREW HEX SOCKET / COUNTERSUNK M 4 X 65
18	1	EAA0344G00A	ENCODER PCB
19	1	1-13004	SCREW PHILLIP PAN HD M 4 X 6
20	2	1-17403	SCREW HEX SOCKET / COUNTERSUNK M 4 X 25
21	1	1-4034	NUT - HEX M 10 X 1 DIN 439
*	1	EAW0239D00A	RIBBON CABLE VIBRATORY
**	1	EAA0260D56A	BRAKE LEVER A CPL.
**	1	EAA0260D57A	BRAKE LEVER B CPL.

CONES AND ACCESSORIES

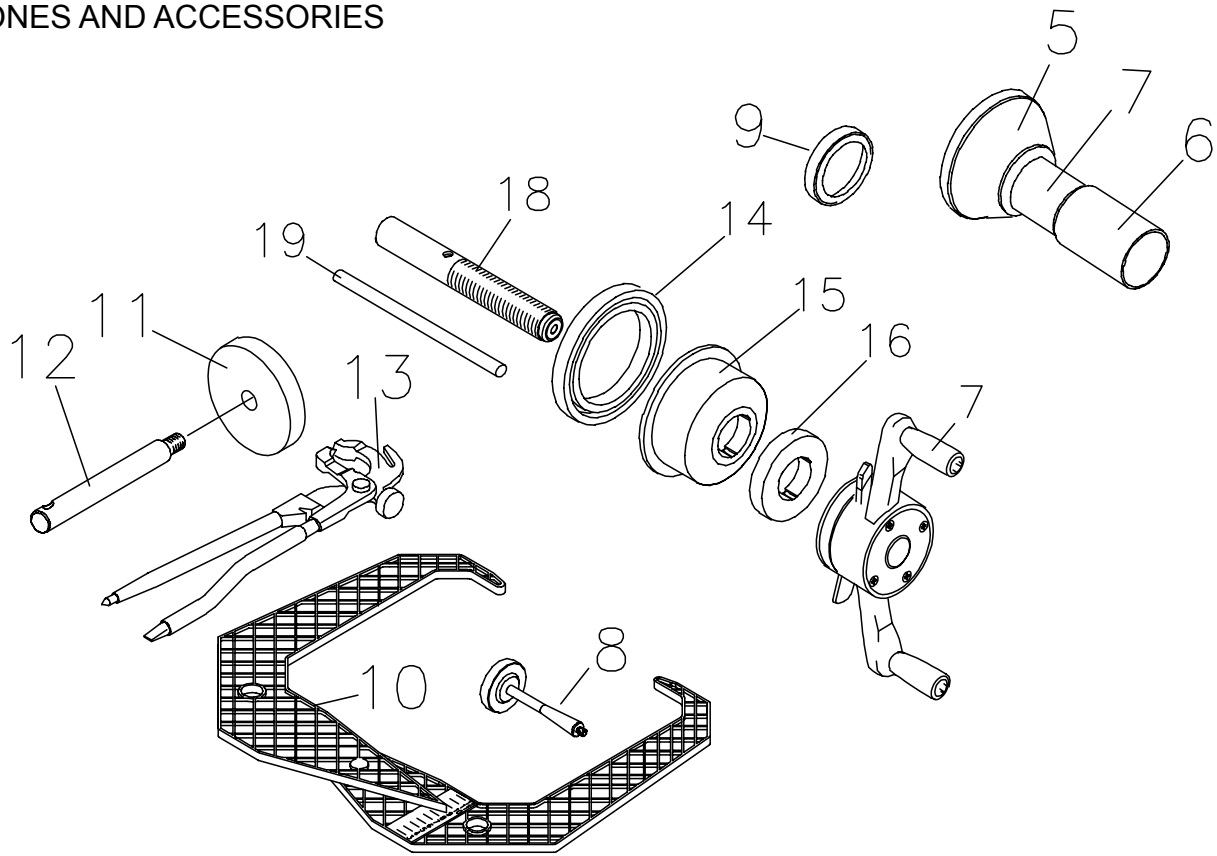

REF	QTY	PART NUMBER	DESCRIPTION
		EAA0307G54A	POWER CLAMP NUT ASSEMBLY
5	1	EAC0058D07A	CUP - LARGE PRESSURE
6	1	EAM0005D54A	PLASTIC SLEEVE
7	1	EAA0283D53A	POWER CLAMP NUT
8	1	EAM0005D40A	CALIBRATION WEIGHT
9	1	EAC0058D08A	SMALL PRESSURE DISK
10	1	EAA0247G21A	CALIPER-RIM WIDTH
11	4	EAC0060G02A	FLANGE - COVER,ACCESS
12	4	EAM0006G01A	HOOK - ACCESSORY STORAGE
13	1	00058839000	TOOL - PDQ WEIGHT
14	1	EAC0058D15A	RUBBER RING
15	1	EAM0058D07A	CUP - PRESSURE
16	1	EAC0058D08A	DISK - PRESSURE
17	1	EAA0263G66A	QUICK NUT
18	1	EAM0021D90A	40 MM STUB SHAFT
19	1	EAM0005D34	FASTENING ROD

4 CONE KIT

EAM0003J08A	CONE, 89-132 MM (3.50 - 5.20 INCHES)
EAM0003J07A	CONE, 71 - 99 MM (3.23 - 3.90 INCHES)
EAM0003J06A	CONE, 56 - 84 MM (2.67 - 3.35 INCHES)
EAM0003J05A	CONE, 43 -63 MM (1.66 - 2.50 INCHES)

7 CONE KIT

EAM0003J64A	CONE - #1, MACHINED (1.70 - 2.23)
EAM0003J65A	CONE - #2, MACHINED (2.30 -
EAM0003J66A	CONE - #3, MACHINED (2.37 -
EAM0003J67A	CONE - #4, MACHINED (2.73
EAM0003J68A	CONE - #5, MACHINED (3.07
EAM0003J69A	CONE - #6, MACHINED (3.42
EAM0003J70A	CONE - #7, MACHINED (4.210

UPPER DISPLAY
EAA0346J92A

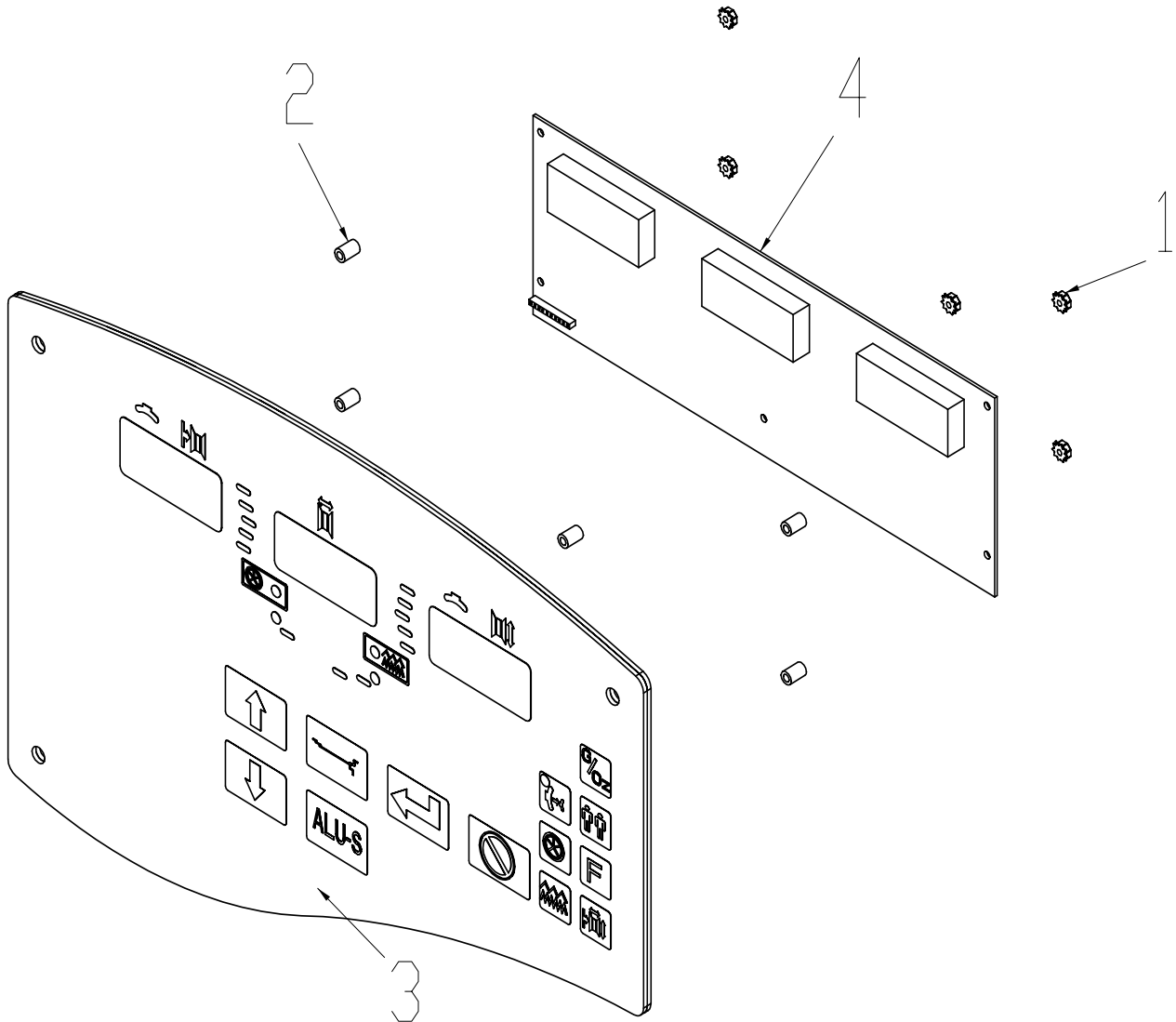

SYM	QTY	PART NO	DESCRIPTION
1	5	1-15033	NUT-KEPS, M3 - .5
2	5	1-11062A	SPACER- 1/4" X 3/8"
3	1	EAA0346J98A	DISPLAY PANEL/ MEMBRANE SWITCH
4	1	EAP0192P80A	PCB ASS'Y-DISPLAY, JB VPI SYS III

WHEEL GUARD AND 3D SAPE

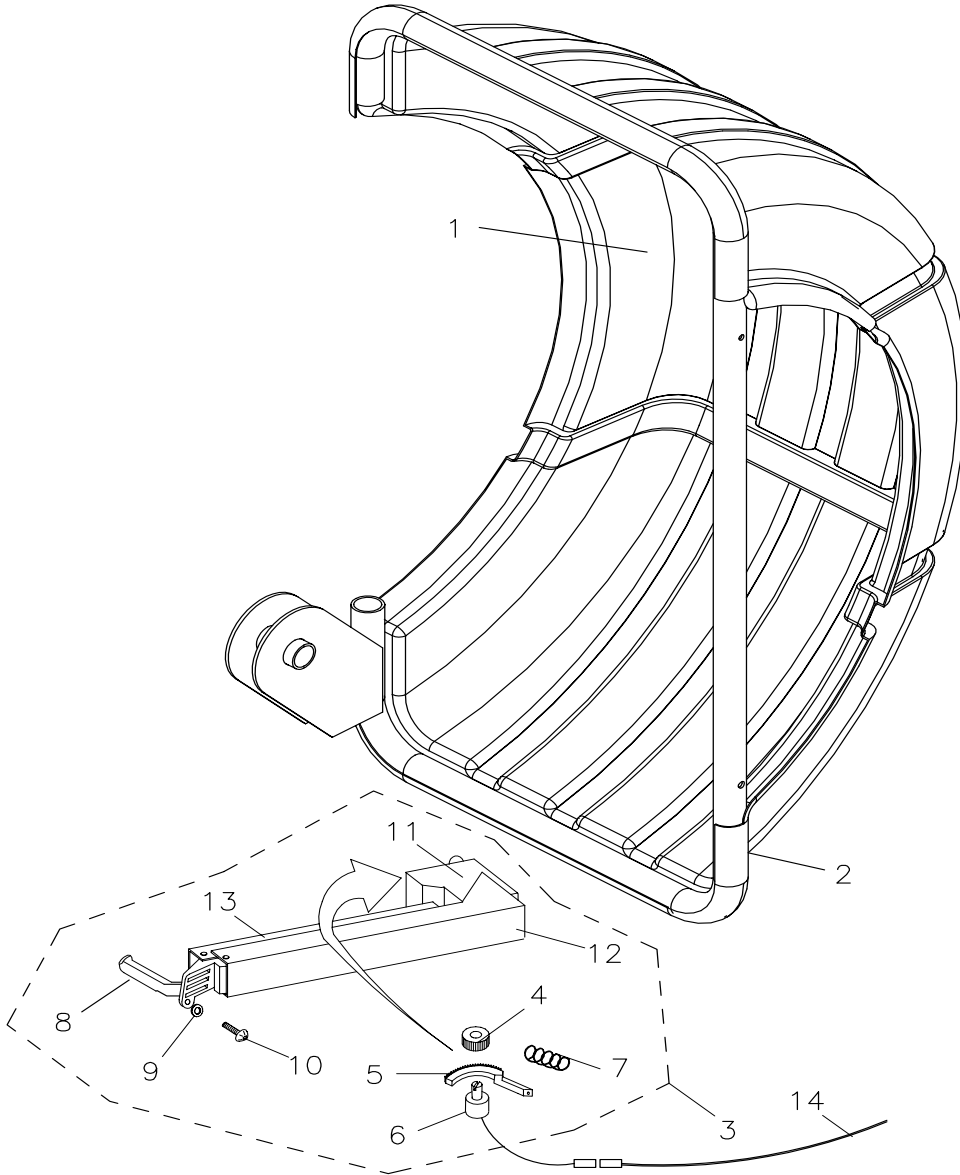

REF #	QTY	REQ.	PART NUMBER	DESCRIPTION
1	1	EAC0053J09A		COVER - WHEELGUARD
2	1	EAS2021J40A		WELDMENT - WHEELGUARD
3	1	EAA0348G73A		3D - P - SAPE
4	1	EAC0058D23A		COG WHEEL
5	1	EAC0058D31A		TOOTHED SPRING TONGUE
6	1	EAA0266D24A		ROTATIVE TRANSDUCER
7	1	1-04067A		TENSION SPRING
8	1	EAC0058D33A		TOUCHING DISK 3DP
9	1			WASHER
10	1			SCREW
11	1	EAC0058D34A		COVER PLATE
12	1	EAS2025D34A		OUTER SHEET
13	1	EAS2025D35A		INNER SHEET
14	1	EAW0239D19A		HARNES FROM POTETIOMETER TO EBOX
*	1	1-04167A		TORSION SPRING

BOM

	PART NUMBER	DESCRIPTION
3	1-01215A	SCREW - LAG, 5/16 X 1 ½
2	1-04076A	HOLE PLUG - 1.5" Ø, BLACK
1	1-1101	SCREW-HHCS 3/8 - 16 X 2
3	1-2541	WASHER - FLAT, 5/16
1	1-8133	NUT-KEPS 3/8-16
6	2-3657	CABLE CLAMP (FLAT CABLE)
1	5403	CERTIFICATE-INSTALL REGISTRAT
1	58839	TOOL - PDQ WEIGHT PASS CAR
1	60677	CHAIN - LAMINATED, INSTRUCTION SHEET
1	60911	WASHER, RETAINING, FLAT
1	EAA0247G21A	CALIPER - RIM WIDTH
1	EAA0263G79A	QUICKNUT KIT-W/ HANDLES & SHAFT
1	EAA0348G73A	SAPE - 3D W/ ADJUSTABLE SPRING
1	EAA0369J03A	BAL ASSY – JB VPI SYS III
1	EAC0053J09A	COVER-WHEELGUARD Y2K
4	EAC0060G02A	FLANGE - COVER, ACCESSORY HOOK
1	EAL0307L00A	LABEL-UL
1	EAL0341J96A	LABEL – BALANCER WARING, REAR
1	EAL0341J97A	LABEL – BALANCER WARING, SIDE
2	1-07024A	SCREW - HH W WASHER M6X10
1	EAL0420J10A	LABEL – JOHN BEAN, BAL
1	EAL0343J76A	LABEL - ELEC/SERIAL
1	EAL0341J25A	HANG SHEET - INSTR SYS III
1	EAL0341J44A	LABEL-ATTENTION, MAX WEIGHT
1	EAL0341J60A	LABEL - PATENT, WHEEL BALANCER
1	EAL0420J13A	DECAL - JB VPI SYS III
4	5-05245A	CABLE TIE – 8"
2ft	01122633000	SPLIT LOOM- WIRE COVER 3/8
1	4500-0029	TIE CABLE (BLACK)
1	EAM0005D40A	CALIBRATION WEIGHT
4	EAM0006G01A	HOOK - ACCESSORY STORAGE
1	EAM0050J00A	TUBE ASSY-WHEELGUARD 44 HNA
1	EAX0039J01A	CORD - POWER, 230V
1	ZEEWB502D9	LIT PACK – JB VPI SYS III
1	EAL0392J89A	LABEL – CUST SERV JBC



John Bean Equipment
309 Exchange Ave.
Conway, AR 72032
501-450-1500

Notice: The information contained in this document is subject to change without notice. Snacon Equipment makes no warranty with regard to this material. Snacon Equipment shall not be liable for errors contained herein or for incidental consequential damages in connection with furnishings, performance, or use of this material.

This document contains proprietary information which is protected by copyright and patents. All rights are reserved. No part of this document may be photocopied, reproduced, or translated without prior written consent