COMPUTER HAND SPIN WHEEL BALANCER

FOR:

PASSENGER CAR & LIGHT TRUCK WHEELS

OPERATION INSTRUCTIONS
Form ZEEWB314A2





SAFETY INFORMATION

For your safety, read this manual thoroughly before operating the Hand Spin Wheel Balancer

The Hand Spin Wheel Balancer is intended for use by properly trained automotive technicians. The safety messages presented in this section and throughout the manual are reminders to the operator to exercise extreme care when servicing tires with these products.

There are many variations in procedures, techniques, tools, and parts for balancing tires, as well as the skill of the individual doing the work. Because of the vast number of wheel and tire applications and potential uses of the product, the manufacturer cannot possibly anticipate or provide advice or safety messages to cover every situation. It is the automotive technician's responsibility to be knowledgeable of the wheels and tires being serviced. It is essential to use proper service methods in an appropriate and acceptable manner that does not endanger your safety, the safety of others in the work area or the equipment or vehicle being serviced.

It is assumed that, prior to using the Hand Spin Wheel Balancer, the operator has a thorough understanding of the wheels and tires being serviced. In addition, it is assumed he has a thorough knowledge of the operation and safety features of the rack, lift, or floor jack being utilized, and has the proper hand and power tools necessary to service the vehicle in a safe manner.

Before using the Hand Spin Wheel Balancer, always refer to and follow the safety messages and service procedures provided by the manufacturers of the equipment being used and the vehicle being serviced.



IMPORTANT !! SAVE THESE INSTRUCTIONS -- DO NOT DISCARD !!



WARNING

· Wheel balancers can cause flying particles

Wear safety glasses. (user and bystanders)



Flying material can cause injury.



WARNING

· Moving components.

Keep self and tools clear of moving parts.



Moving components can cause injury.

IMPORTANT SAFETY INSTRUCTIONS

When using this equipment, basic safety precautions should always be followed, including the following:

1. Read all instructions.
2. Do not operate equipment with a damaged power cord or if the equipment has been damaged - until it has been examined by a qualified authorized service technician.
3. If an extension cord is used, a cord with a current rating equal to or more than that of the machine should be used. Cords rated for less current than the equipment may overheat. Care should be taken to arrange the cord so that it will not be tripped over or pulled.
4. Always unplug equipment from electrical outlet when not in use. Never use the cord to pull the plug from the outlet. Grasp plug and pull to disconnect.
5. To reduce the risk of fire, do not operate equipment in the vicinity of open containers of flammable liquids (gasoline).
6. Keep hair, loose fitting clothing, fingers and all parts of the body away from moving parts.
7. Adequate ventilation should be provided when working on operating internal combustion engines.
8. To reduce the risk of electric shock, do not use on wet surfaces or expose to rain.
9. Do not hammer on or hit any part of the control panel with weight pliers.
10. Do not allow unauthorized personnel to operate the equipment.
11. Use only as described in this manual. Use only manufacturer's recommended attachments.
12. Always securely tighten the wing nut before spinning the shaft.
13. ALWAYS WEAR SAFETY GLASSES. Everyday eyeglasses only have impact resistant lenses, they are NOT safety glasses.
14. Balancer is for indoor use only.

SAVE THESE INSTRUCTIONS

TABLE OF CONTENTS

SAFETY INFORMATION	1
1.0 INTRODUCTION	4
1.1 SAFETY NOTICE	4
1.2 BALANCER APPLICATION	4
1.3 SPECIFICATIONS	5
1.4 FEATURES	5
1.5 STANDARD ACCESSORIES	6
1.6 OPTIONAL ACCESSORIES	7
1.7 DIMENSIONS OF THE MACHINE	7
1.8 REQUIRED INSTALLATION AREA	7
2.0 INSTALLATION INSTRUCTIONS	8
2.1 SHAFT ADAPTER INSTALLATION	8
3.0 TERMINOLOGY	9
4.0 OPERATION OF THE BALANCER	10
4.1 CHECK LIST - INSPECTION	10
4.2 WHEEL MOUNTING	10
4.2.2 CENTERING LIGHT-TRUCK WHEELS	11
4.3 MODE SELECTION	11
4.3.1 WEIGHT PLACEMENT MODES	11
4.4 SELECTING OPERATOR PREFERENCES	12
4.4.1 FINE BALANCING MODE	12
4.4.2 OUNCE/GRAMS CONVERSION	12
4.4.3 RIM DIAMETER IN MILLIMETERS	12
4.5 ENTER RIM PARAMETERS	13
4.5.2 MEASURE RIM WIDTH	13
4.5.3 RIM DIAMETER	13
4.6 CORRECTION OF THE IMBALANCE	14
4.7 VERIFICATION OF THE RESULTS	14
4.8 VIBRATION PROBLEMS	14
5.0 TIRE MATCHING PROGRAM - P90	15
6.0 OPTIMIZATION ROUTINE- P91	17
7.0 ALU-S MODE	18
8.0 USER CALIBRATION - P14	19
9.0 RIM OFFSET GAUGE CALIBRATION - P80	20
10.0 EXPLANATION OF PROGRAM CODES	20
11.0 MAINTENANCE	21
12.0 TROUBLE SHOOTING	21

1.0 INTRODUCTION

Congratulations on purchasing the Hand Spin computer wheel balancer. This wheel balancer is designed for ease of operation, accuracy, reliability and speed. With a minimum of maintenance and care your wheel balancer will provide many years of trouble-free operation.

Instructions on use, maintenance and operational requirements of the machine are covered in this manual.

**STORE THIS MANUAL IN A SAFE PLACE FOR FUTURE REFERENCE.
READ THIS MANUAL THOROUGHLY BEFORE USING THE MACHINE.**

1.1 SAFETY NOTICE

This manual is a part of the balancer product.

Read carefully all warnings and instructions of this manual since they provide important information concerning safety and maintenance.

1.2 BALANCER APPLICATION

The Hand Spin wheel balancer is intended to be used as a device to balance car, light truck wheels within the following range:

<i>Maximum tire diameter</i>	<i>:</i>	<i>44" (1117mm)</i>
<i>Maximum wheel width</i>	<i>:</i>	<i>16" (530mm)</i>
<i>Maximum wheel/tire weight</i>	<i>:</i>	<i>120lbs (54 kg)</i>

*This device is to be only used in the application for which it is specifically designed.
Any other use shall be considered as improper and thus not reasonable.*

The manufacturer shall not be considered liable for possible damages caused by improper, wrong or non reasonable use.

1.3 HAND SPIN SPECIFICATIONS

Computerized digital wheel balancer for car, light truck wheels.

Weight Imbalance Accuracy	.05 oz / 1 grams
Weight Placement Resolution	± .7 degrees
Weight Imbalance Resolution:	
Roundoff Mode	.25 oz / 5 grams
Non-Roundoff Mode	.05 oz / 1 gram
Max. Shaft Weight Capacity	120 lbs / 54 kg
Max. Tire Diameter	44" / 1118 mm
Rim Width Capacity	3"-16" / 76 mm - 508 mm
Max. Tire Width	20" / 508 mm
Rim Diameter Capacity	6"-28" / 152 mm-635 mm
Balancing Cycle Time.	15 seconds or less
Shaft Speed at calculation	119 RPM
Electrical	115/230vac, 1ph, 50-60Hz, 2A Battery - 12, 14, or 18 volt Versavolt
Required Work Area	58"w x 48"d 1473 x 1219 mm
Shipping Weight, unit/pallet/carton	150 lbs/68kg
Shipping Dimensions	48"h 40"w 28"d
Machine Dimensions	40"h 38"w 21"d
Actual Weight with Accessories	125 lbs / 57 kg
Operating Temperature Range	32-122F / 0-50C

1.4 FEATURES

ACCURACY

- Weight placement accuracy to as low as ± .7°
- Weight imbalance accuracy to 1 grams.
- Self test check with every power up cycle.
- Fast operator calibration.
- Pre-programmed Error Codes indicate procedural errors or safety concerns.

SPEED and DURABILITY

- Small footprint for compact installation.
- Automatic distance entry. Simply touch the distance arm to the wheel and distance parameter is automatically entered.
- Quick clamp speed nut reduces the mounting time.
- Captured back spring eliminates having to handle the backing spring.
- Quick cycle time.
- Automatic recalculation if weight positions are changed. No need for re-spinning the wheel.
- Common 28.5 mm diameter mounting shaft.
- Weight pocket storage tray.
- Easy-to-Read Data display.
- Easy weight tray access.

SOFTWARE VERSATILITY

- Both dual weight Dynamic and single weight Static capability.
- Match Balance program for reducing balancing weight required.
- Built-in spin counter for monitoring balancer productivity.
- Service code access to all Balancer electronic functions for fast, easy diagnosis.
- Operator selectable roundoff mode.

1.5 STANDARD ACCESSORIES

Centering Cones and Accessories

For centering of wheels with center holes

1	EAM0003J13A	Cone, 85-132 mm / 3.36"-5.2"
2	EAM0003J12A	Cone, 71-91 mm / 2.8"-3.6"
3	EAM0003J11A	Cone, 56-84 mm / 2.18"-3.3"
4	EAM0003J10A	Cone, 43-64 mm / 1.7" - 2.5"
5	8 - 02040A2	Cup - Pressure
6	110410	Ring Protector
7	8 - 02040A	Quick Nut - includes 7A
7A	8 - 02040A1	Disk - Pressure
8	EAM0005D40A	Weight - Calibration
9	EAM0005D14A	Stub Shaft
10	8 - 01050A	Wrench - Fork, 19mm
11	EAA0247G21A	Caliper - Rim Width
12	EAC0060G02A	Flange - Cover, Hook
13	EAM0006G01A	Pin - Accessory
14	CTB312	Versavolt Battery, 12vdc
15	CTC318	Versa Charger
*	7-14201a	120vac to 9vac adapter

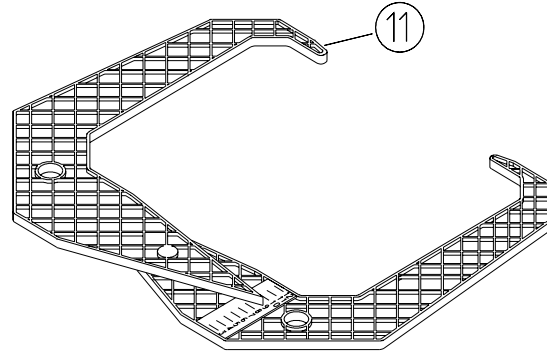
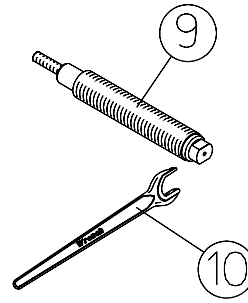

* Not Shown

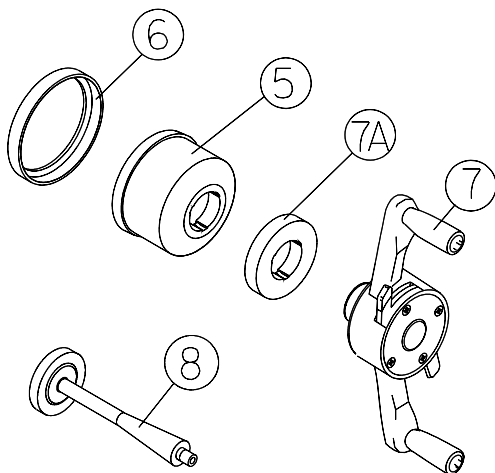
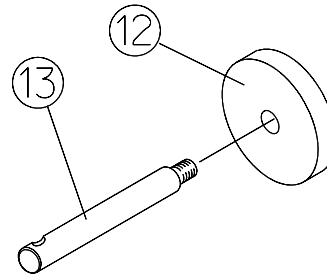
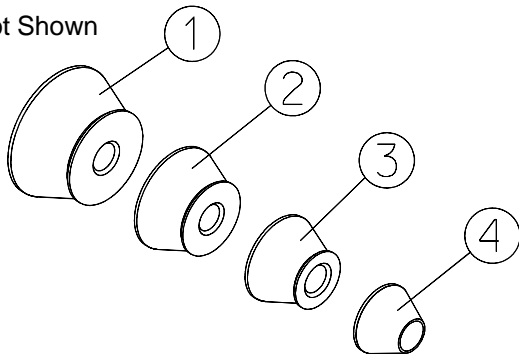

Figure 1



Figure 2

1.6 OPTIONAL ACCESSORIES

Weight Pliers P/N 58839 (Fig.3).

Versatile weight hammer/plier. In addition to hammering on weight and used weight removal, the 58839 can be used to reshape worn weight clips and trim weight to size.

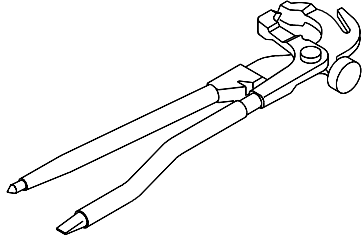

Figure 3

PRE-INSTALLATION CONSIDERATIONS

1.7 DIMENSIONS OF THE MACHINE

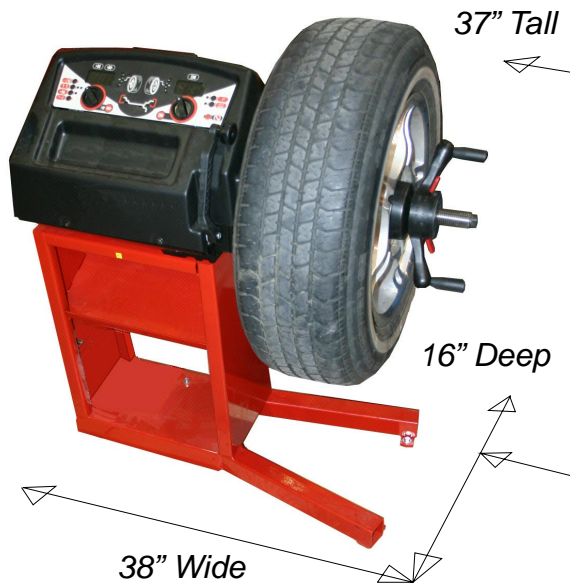

Figure 4

For actual physical dimensions refer to Figure 4.

1.8 REQUIRED INSTALLATION AREA

Make sure that from the operating position the user can see all of the machine and the surrounding area.

The operator should prevent non authorized persons and/or objects from entering the area which may create potential hazards.

The machine should be installed on a level floor. Do not install the machine on a sloped or irregular floor.

If the balancer is to be installed on a raised floor, the floor must have a capacity of at least 110lbs per sq ft. (5000 N/m² - 500 kg/m²).

Install the machine in a dry, covered area.

The installation of the machine requires a working area of at least 58" x 48" (1473 x 1219 mm) (Fig.5).

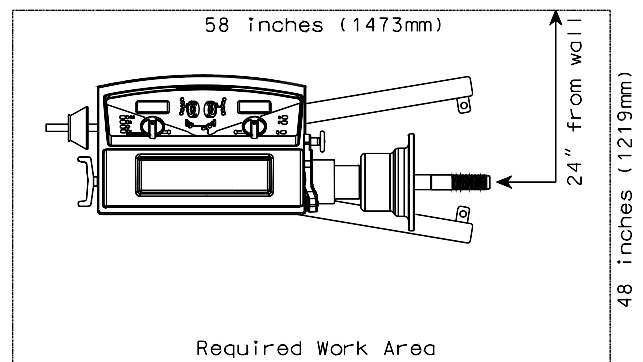

Figure 5

2.0 INSTALLATION INSTRUCTIONS

CAUTION! CAREFULLY REMOVE THE BALANCER FROM THE PALLET. THE UNIT IS HEAVY AND THE WEIGHT IS NOT EVENLY DISTRIBUTED.

DO NOT LIFT THE BALANCER BY THE SHAFT.

DROPPING THE UNIT MAY CAUSE PERSONAL INJURY OR EQUIPMENT DAMAGE.

Two Mounting Options are available:

1 - Preferred, secure the balancer to the floor using the supplied concrete anchors - or -

2 - Mount the cabinet brace as shown in Figure 6.

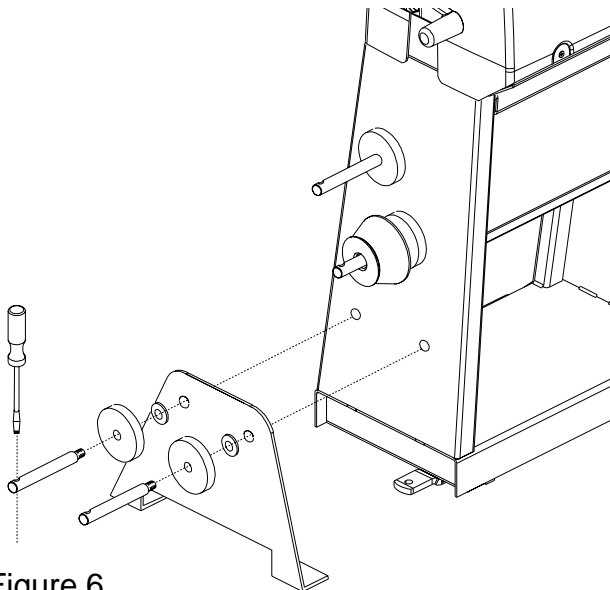

Figure 6

If mounting with the concrete anchors, locate the balancer where operation is desired, mark the floor and drill the three holes. Place balancer over the holes and tap in anchors. Tighten nuts until secure.

If anchors are not desired the balancer can be securely operated by mounting the brace to the left side of the balancer cabinet using the two lower accessory pins with washers, see Figure 6 for assembly detail.

Install the remaining accessory pins onto left side of balancer cabinet and tighten firmly.

Place cones and other accessories onto the accessory pins.

2.1 SHAFT ADAPTER INSTALLATION

IMPORTANT!
CHECK THAT THE SURFACES ARE PERFECTLY CLEAN AND NOT DAMAGED. AN INCORRECT MOUNTING MAY RESULT IN SIGNIFICANT IMBALANCE.

A. Mount the threaded shaft onto the arbor of the balancer. Tighten firmly using the supplied wrench. (Fig.7).

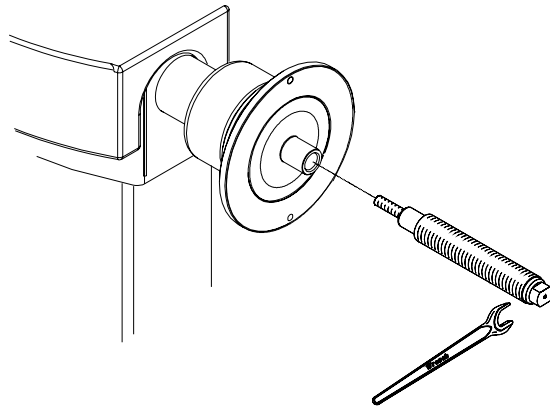

Figure 7

2.2 ELECTRIC INSTALLATION

ANY ELECTRICAL WIRING MUST BE PERFORMED BY LICENSED PERSONNEL.

ALL SERVICE MUST BE PERFORMED BY AN AUTHORIZED SERVICE TECHNICIAN.

Check on the plate of the machine that the electrical specifications of the power source are the same as the machine. The machine uses 115VAC, 50-60Hz, 1Ph, 2.0 Ampere, or a 12 volt DC VersaVolt Battery.

Battery Operation

Place the 12 volt VersaVolt battery into the charger and charge until a full charge is indicated. Remove the battery from the charger and insert the battery into the receptacle at the rear of the balancer. Switch the ON/OFF switch to the battery operate mode.

NOTE:

Any electrical outlet installation must be verified by a licensed electrician before connecting the balancer.

PLEASE NOTE:

This machine performs a self-test routine on start-up. There will be a delay of several seconds before the display is activated.

3.0 TERMINOLOGY

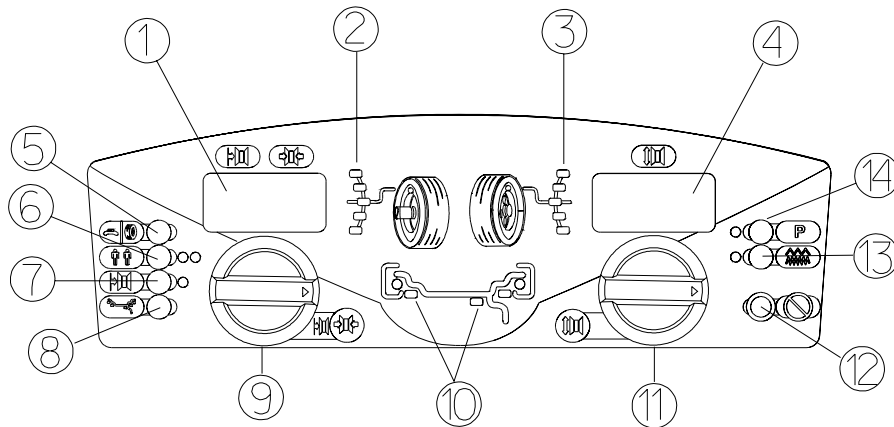

Figure 8

Before using the wheel balancer it is suggested that you become familiar with the terminology of the machine's components. Refer to Figures 8 and 9.

1. ***Inner plane imbalance value display***
2. ***Inner plane imbalance position indicator***
3. ***Outer plane imbalance position indicator***
4. ***Outer plane imbalance value display***
5. ***Display all parameters button***
6. ***Operator A-B toggle button***
7. ***Rim offset button***
8. ***Mode select button***
9. ***Rim width/offset knob***
10. ***Balance mode indicator***
11. ***Diameter/Function knob***
12. ***Cancel/Stop button***
13. ***Fine-Normal button***
14. ***"P" codes button***
15. ***Accessories storage location***
16. ***Rim offset gauge arm***
17. ***Arbor - shaft adapter***

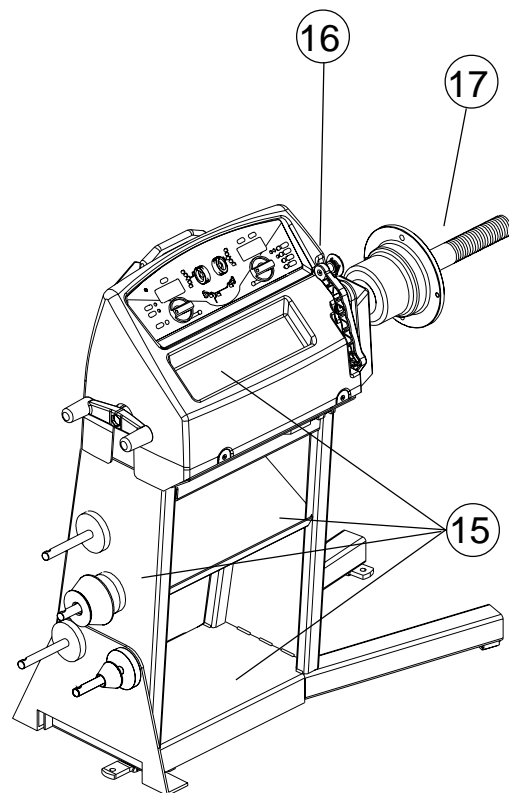

Figure 9

4.0 OPERATION OF THE BALANCER

WARNING: For operator safety please read and follow the precautions outlined on pages 1 and 2 of this manual.

NOTE: Read all instructions before proceeding with operation of the balancer.

All balancer functions are input into the main computer through the large easy to read touch panel. Although each wheel tire assembly differ in some ways all balancing jobs require basically the same procedure. The order of events to take place are:

1. Inspection of the wheel/tire assembly
2. Mounting wheel onto shaft or adapter
3. Selection of Balancing Mode or placement
4. Entry of wheel parameters
5. Spinning the wheel
6. Applying the recommended weight
7. Check spin if desired
8. Dismounting the wheel

The following operation instructions will follow the basic outline above.

4.1 CHECK LIST - INSPECTION Observe Before Balancing Wheel

1. Check for proper air pressure. If not correct, inflate to correct pressure.
2. Check for any foreign material inside tire. If present, remove before balancing tire.

WATER IS FOREIGN MATERIAL!

3. Remove old weights — old weights may be improper value or in wrong location.
4. Be sure tire and wheel are free of excessive dirt, rust and large stones. Use wire brush on back side of wheel if necessary.
5. Be sure that the right size tire has been mounted on the wheel.

4.2 WHEEL MOUNTING

Most standard wheels and alloy wheels have accurately machined center holes, and they should be mounted with center cones. Accurate balancing depends on accurate mounting of the wheel and correct seating of the cone in the pilot hole. Insure that the wheel is centered on the shaft exactly as it will be mounted to the vehicle.

Before starting any balancing procedure it is very important that the wheel is mounted on the machine with the proper adaptors. An incorrect centering of the wheel will result in considerable imbalance.

There are many types of wheels, adaptors of good quality and durability are supplied for the large majority. However if you meet special wheels which may require a specific adaptor, call your authorized equipment distributor.

Rims may be divided into these major groups:

1. Car rims with a true center hole.
2. Car rims without a center hole.
3. Car rims with an untrue center hole.
4. Light truck rims.

4.2.1 Standard Wheels (back cone mount)

Mount the wheel as detailed below in Figure 10:

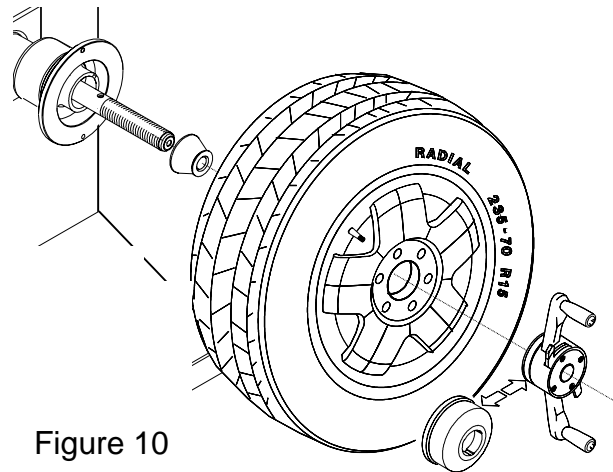

Figure 10

1. Mount proper cone against spring plate.
2. Mount wheel on shaft in the same manner as you would on the car.
3. Mount pressure cup on shaft and place against outside of wheel, follow with the Quick-nut.
4. Tighten Quick-nut securely with both hands.

To operate the Quick-nut pull the lock-unlock lever (Fig.11). Slide the Quick-nut on the threaded shaft. When in contact with the rim, release the unlock lever and tighten firmly. To assist in centering the wheel properly, rotate the wheel on the shaft while tightening the quick nut.

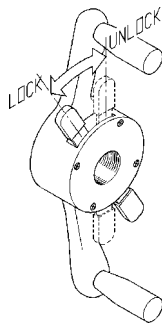

Figure 11

DO NOT USE A HAMMER TO TIGHTEN THE QUICK NUT.

TO RELEASE THE QUICK NUT, UNSCREW A FEW TURNS TO REDUCE THE AXIAL PRESSURE, THEN PRESS THE UNLOCK LEVER AND SLIDE AWAY FROM THE SHAFT.

FAILURE TO TIGHTEN WING NUT SECURELY MAY RESULT IN SERIOUS PERSONAL INJURY.

5. Check that the wheel rotates true by turning the wheel several revolutions while noting any excessive runout.

4.2.2 CENTERING LIGHT-TRUCK WHEELS

An optional offset spacer may be required for some light truck wheels and reverse-offset wheels that must be moved away from the balancer mounting flange. The extension adaptor is often used with the 5-1/2 inch diameter light truck cone.

Install the spacer on the mounting flange, then mount the wheel, using the front cone method (Fig. 12)

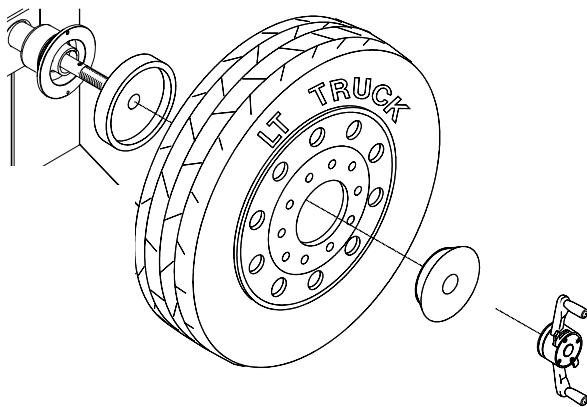

Figure 12

4.3 MODE SELECTION

The majority of balancing takes place in the default 2-plane dynamic mode which is displayed as "2 PL" (location 1, see figure 14). Hammer-on clip weights will be placed on both inside and outside of the rim edge. If required, select an optional weight placement mode by pressing the *Mode* button until the appropriate placement mode is displayed.

4.3.1 WEIGHT PLACEMENT MODES

Before spinning the wheel (although it may be done afterwards) choose the appropriate balancing mode for the wheel. To select the various placement modes press the *Mode* button (#8 Fig. 13) until placement LEDs indicate desired placement position.

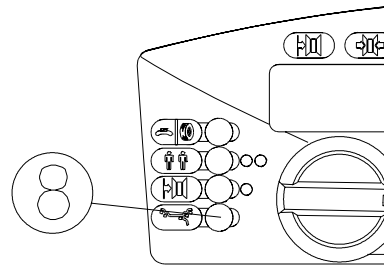

The balancing modes available are: Figure 13

A. DYNAMIC (two planes), suggested for all steel rims. In this case the wheel weights must be clipped onto the rim edges. This function is selected as a default and the LEDs corresponding to the wheel weight location are lit on (Fig. 14).

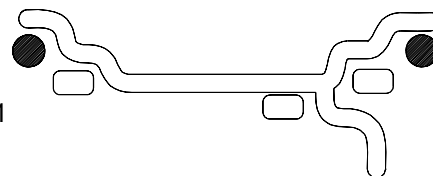

Location 1

Figure 14

B. STATIC (single plane - Fig. 15). Suggested for narrow rims (3" or less). Use a single corrective weight placed in the center of rim as illustrated in Figure 15.

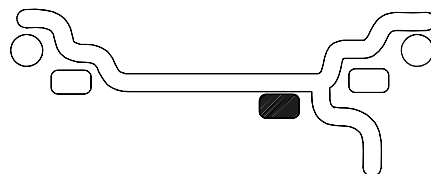

Figure 15

C. ALUMINUM MODES. Balancing using a combination of hammer-on and adhesive weights as shown in Figures 16 thru 20.

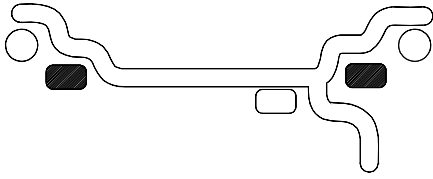

Figure 16 **ALU 1**

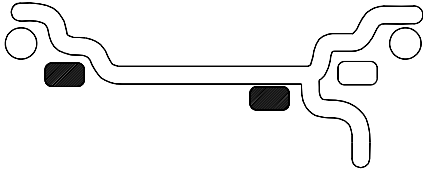

Figure 17 **ALU 2**

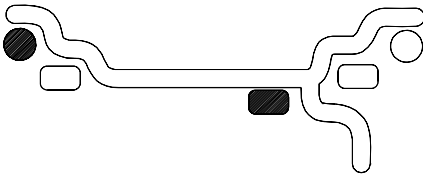

Figure 18 **ALU 3**

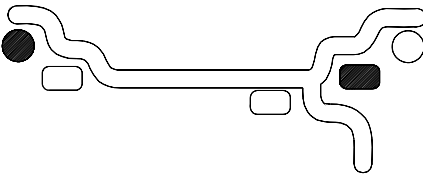

Figure 19 **ALU 4**

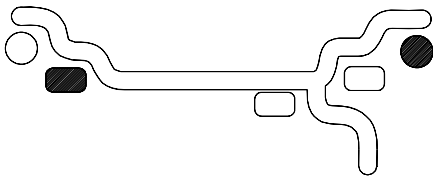

Figure 20 **ALU 5**

TO RETURN TO THE *DYNAMIC* PROGRAM FROM ANY OF THE *ALU* PROGRAMS, JUST PRESS Cancel/Stop.

4.4 SELECTING OPERATOR PREFERENCES

4.4.1 FINE BALANCING MODE

This balancer measures with the maximum precision available all the time, 1g / 0.05 oz, however values below 5g / 0.25 oz are shown as zero while in the normal operating mode. Values exceeding 5g / 0.25 oz are rounded to the amount of the nearest commercial wheel weight.

Press and hold the NORMAL/FINE button to toggle the display resolution between 5g / 0.25 oz and 1g / 0.05 oz.

4.4.2 OUNCE/GRAMS CONVERSION

When the machine is first turned on it is preset to display the imbalance in ounces.

If the display in grams is desired, press and hold the *P* button while rotating the Function knob until "P 3" is displayed".

Repeat the procedure for converting back to ounces.

4.4.3 RIM DIAMETER IN MILLIMETERS

The rim diameter is normally displayed in inches, however if the value in millimeters is desired, press and hold the *P* button while rotating the Function knob until "P 7" is displayed".

Repeat the above operation to convert back to inches.

Example: "dIA ICH" = inches

"dIA ---" = millimeters

4.5 ENTER RIM PARAMETERS

4.5.1 Distance (rim offset) - Grasp the offset gage arm at the end of the shaft and move outward to the edge of the rim, touch the pointer to the rim edge as illustrated in *Figure 21* and hold steady for about a second. Avoid flexing the measurement arm extension. The beeper will sound and the distance values will be entered automatically. Return the arm to its fully in and rest position on the balancer. Do not allow the measurement arm to "dangle" down in front of the balancer.

Manual Distance Entry - In the event of automatic gauge failure, the distance value can be input manually. Move the distance gauge arm to touch the inner edge of the wheel where weights are to be placed and observe the reading on the scale of the distance gauge. Press manual wheel distance button  while rotating distance knob until value is displayed in the left display window.

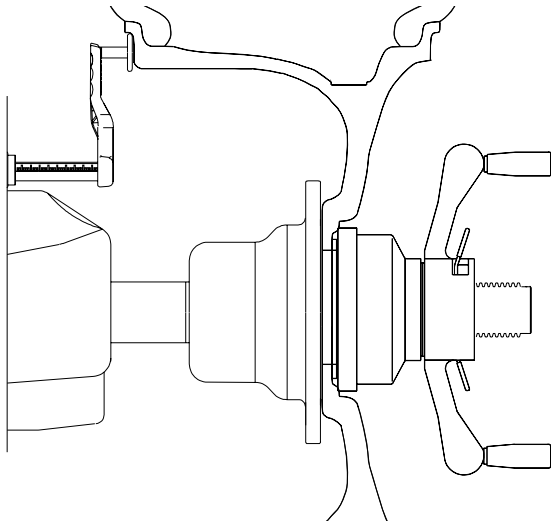

Figure 21

NOTE: For precision balancing of performance wheels, an "ALU-S" Mode is available for precision determination of wheel parameters. This feature allows exacting placement of corrective weights as well. See *Page 18* for detailed instructions.

4.5.2. Measure rim width

Use rim width calipers, measure wheel where corrective clip-on weight would be applied, *Figure 22*. Enter the measured width by rotating the width/offset knob until the desired value appears in the left display.

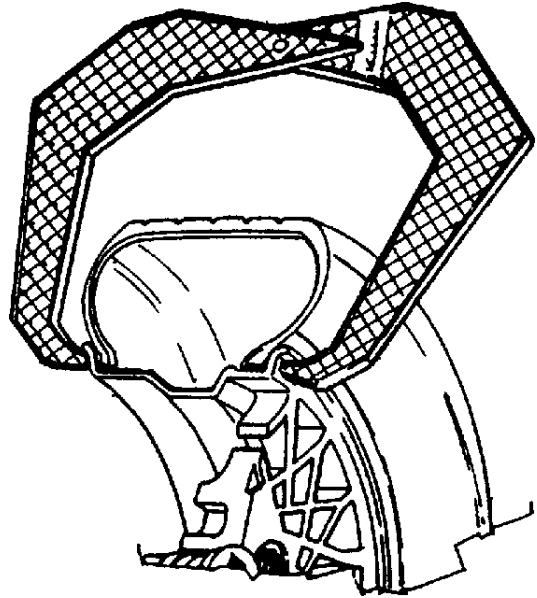

Figure 22

4.5.3. Rim Diameter

Read the rim diameter marked on the sidewall of the tire (*Fig.23*). Enter the measured rim diameter by rotating the diameter/function knob until the desired value appears in the right display.

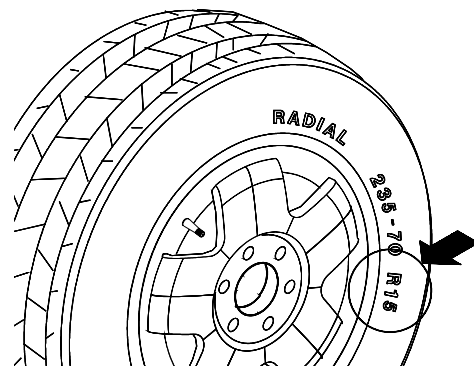

Figure 23

4.6 CORRECTION OF THE IMBALANCE

NOTE: Before spinning the wheel make sure proper eye protection is worn by all personnel in the vicinity of the balancer.

A. Use hand crank Quick-nut to spin the wheel up to speed. A tone will sound when sufficient speed is attained. When the balancing cycle is completed the wheel will stop automatically and the imbalance values will appear on the LED's.

B. Read the imbalance value on the outer display. Values are displayed in ounces but can be displayed in grams if required and are automatically rounded to the nearest commercial wheel weight.

Turn the wheel until the displays of the outer plane imbalance position indicator are illuminated green. Apply the wheel weight at twelve o'clock position.

C. Correct the imbalance on the inner plane in the same manner.

4.7 VERIFICATION OF THE RESULTS

Spin the wheel again and check that the readout is "0.00" "0.00" If a residual imbalance is displayed:

A. Check the rim parameters, if entered value is incorrect, correct as needed. Imbalance values will be automatically recomputed.

B. Check if the balancing mode selected is the most appropriate. If not, choose the right mode and respin.

C. The wheel weight could have been placed at a wrong position. To check this, position the wheel at the correction position for the outer plane. If the wheel weight previously attached is in sector 'L' or 'R' (Fig.24), move the wheel weight up about 1" (2.54cm).

If the wheel weight is in sector 'D' cut a piece of the wheel weight of an approximate value corresponding to the value shown on the right display, or replace the wheel weight with a lighter one.

If the wheel weight is in sector 'U' add a weight of value indicated by the display or replace the wheel weight with a heavier one. Repeat the same operation for the inner plane.

NOTE: If this situation is repeated, your machine may be out of calibration and a calibration operation might be required

D. If an *ALU* function was selected ensure that the wheel weights have been placed in accordance to the program chosen.

E. Check that the quick nut is tight and that the wheel is not slipping against the backing collar.

F. Check that the wheel and adaptors are clean.

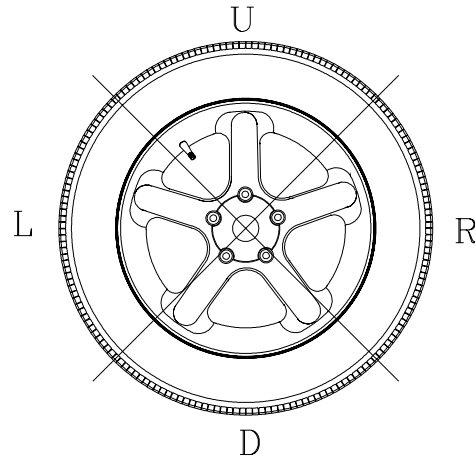

Figure 24

4.8 VIBRATION PROBLEMS

If vibration is still present after balancing, check the following possible sources of vibration:

1. Stones caught in the tire tread.
2. Tire slippage on the wheel.
3. Incorrectly mounted wheel.
4. Imbalanced wheel covers.
5. Excessive radial or lateral runout in the tire or wheel.
6. Damaged wheel bolt holes.
7. Worn universal joints.
8. Imbalanced brake rotors or drums.
9. Worn or damaged balancer accessories.

5.0 TIRE MATCHING PROGRAM - P90

Tire matching assists the user in determining the best possible mating of the tire and rim. The mating of tire and wheel normally allows the least amount of additional weight required for balancing and total runout.

The matching program is helpful when:

- Excessive radial runout is noticed.
- The balancer calls for weights in excess of 2 oz. on either plane in the *Dynamic* mode.

The **Hand Spin** computer wheel balancer features a matching program capable of two levels of resolution:

Dynamic, to rotate *and* reverse the tire on the rim for optimum mating.

Static, when the tire has an ornate sidewall or directional tread and cannot be reversed on the rim.

INSTRUCTIONS:

1. Press and hold the **P** button while turning the *Diameter/Function* Knob until the display reads "P" "90".

When activated the machine displays "--- ACH" for one second followed by "VAL tOP". This instructs the operator to rotate the wheel so the valve is at 12 o'clock. See *Figure 25*. Press "P" to store the valve position, the display will then read "SPN 1".

NOTE: The P button can be pressed more than once, every time the P button is pressed, the valve position is remembered by machine as a reference point.

2. Spin the wheel, when the shaft reaches the balancing speed, the display reads "ACH 1" with a beep.

3. After spinning the shaft brake engages and the display reads "tur tir" and "CrS tOP" alternatively.

(1) The operator should turn the wheel and mark an X at the 12 o'clock when the valve is at the 6 o'clock position. *Figure 26*

(2) Deflate and rotate the tire on the rim so the valve points to the cross mark on tire. *Figure 27*

4. After inflating the tire and remounting on shaft, press P button. The machine displays "VAL tOP" again. Operator should turn wheel so the valve is at 12 o'clock. And then press P button to program the valve position.

NOTE: The P button can be pressed as often as necessary, with every press the machine updates the memory of the valve position.

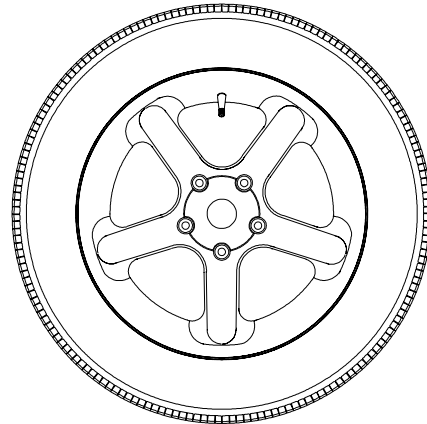

Figure 25 - Step 1, valve top, press "P"

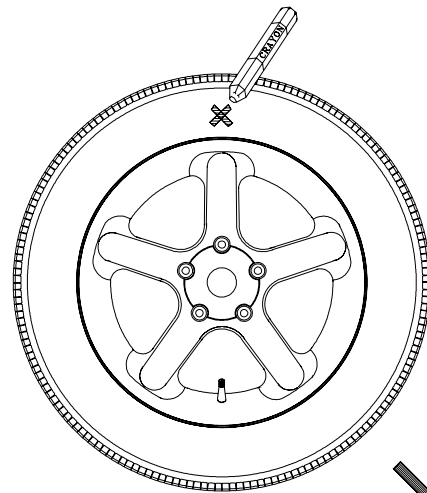

Figure 26 - Step 2, valve at bottom, mark top of tire with X, press "P"

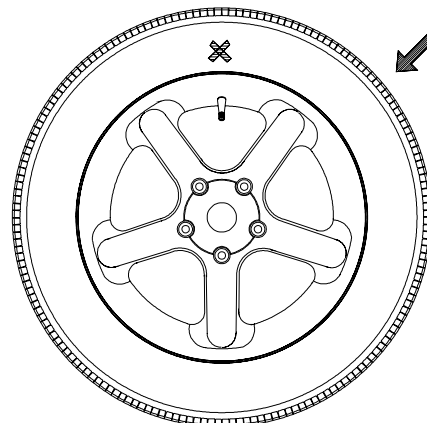

Figure 27 - Step 3, rotate tire on wheel so the valve and X mark line up. Rotate assembly to TDC, press "P".

5. The machine displays "SPN 2 ". Spin the wheel, when the shaft reaches the balancing speed, machine displays "ACH 2" along with a beep.

6. Once the spin cycle is complete, the display reads "CAL CUL" for one second. Machine calculates the results based on the previous two spins.

From this point, there are three possible procedures to conclude the match balance routine. These 3 procedures are quite different depending on the results of calculation.

Procedure 1

The imbalance measured in spin 2 has been reduced to an acceptable amount, less than 2 oz, and it will not be necessary to continue match balance. The display reads "ACH FIN" for one second, and then proceeds to the normal two-plane balancing mode and displays the weight imbalance amount and its position for both planes.

Procedure 2

Due to a large amount of remaining imbalance the operator can continue match mount. Machine displays "CrS" "r" and "tur" "tir" alternatively. This instructs the operator to turn the wheel and make a double cross mark (XX) on the right side of the tire at 12 o'clock position when the right center position LED turns to green. See Figure 28.

NOTE: If you do not intend to continue minimization, you can press the Cancel/Stop button

If the Cancel/Stop button is pressed now, machine displays "Qit Qit" for one and half second to remind operator whether he wants to quit optimization or not. If one presses Cancel/Stop button immediately, the program goes to procedure 1. If not, after one and half second, machine returns to the optimization procedure.

To continue with optimization: Deflate the tire and then turn the valve to point the XX mark on the tire. Remount tire/wheel onto shaft, press "P" when ready to continue.

1. The machine displays "VAL tOP". Turn the wheel so the valve is at top position. (12 o'clock) and then press P button. The machine stores the valve position. See Figure 29.

2. The machine displays "SPN 3 ". Spin shaft until a beep sound is heard. Machine displays "ACH 3 ".

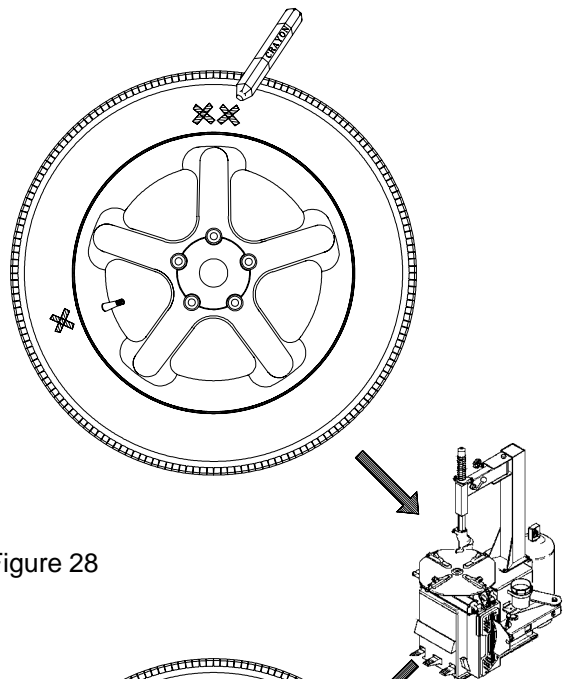

Figure 28

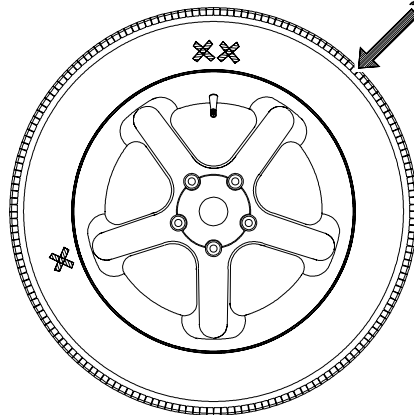

Figure 29

3. Display will read "ACH CHC" for one second. Balancing results are checked whether or not the matching balancing has been achieved.

4. There are two results that could be given by the previous step:

1 - *Match Balance failure*. Machine displays: "FAI L " for one second and then goes to idle state.

2 - *Match Balance is successful*. Machine displays: "ACH FIN" for one second and then goes to normal two plane balancing mode. Machine displays the recalculated weights and their position taking the matching results into account.

Procedure 3

1. Machine displays "CrS L" and "FLP tir" alternatively. When the left center position LED turns to green this instructs the operator to turn the wheel and mark a XX on the left side of the tire at 12 o'clock position.

2. If the tire can not be flipped, just press Cancel/Stop button to force machine to procedure 2.

But sometimes, the machine does not allow the operator to give up flipping tire due to the results of the calculation. In this case, machine displays "NO NO " for one and half second. If the operator has no response for this information, the machine goes back to above state after one and half second. If one press Cancel/Stop button within one and half second, machine will display "Quit Quit" for one and half second to remind operator whether or not he wants to quit optimization. If operator press Cancel/Stop button within one and half second, machine goes to normal balancing mode and displays the weights and their positions. If not, machine goes back to above state.

If optimization is to be continued with flipping tire, proceed as described below.

3. Deflate the tire then flip, turning the valve to point the XX mark on the tire (as in procedure 2).

4. Inflate the tire and mount it to shaft again. Press the P button.

5. The machine displays "VAL tOP". Turn the wheel to make valve at top position. (12 o'clock) and then press P button. The machine will store the valve position.

6. The machine displays "SPN 3 ".

NOTE: The P button can be pressed as often as necessary, with every press the machine updates the memory of the valve position.

7. Spin shaft until a beep sound is heard. Machine displays "ACH 3 ". It is under data acquisition and do not disturb the machine while it is acquiring data.

8. After balancing is done, the machine displays "ACH CHC" for one second. Machine processes the balancing results to check whether or not the matching balancing has been achieved.

9. There are two results could be given by the previous step.

1. *Matching balancing failure*. Machine displays: "FAI L " for one second and then goes to idle state.

2 - *Match Balance is successful*. Machine displays: "ACH FIN" for one second and then goes to normal two plane balancing mode. Machine displays the recalculated weights and their position taking the matching results into account.

6.0 OPTIMIZATION ROUTINE- P91

The Optimization Routine is very similar to that of the Match Mount Program (P90). The main difference is that operation begins with a bare rim instead of a rim-tire assembly.

7.0 ALU-S MODE

This is a mode similar to the ALU mode 2 and 3. The difference is the distance and width parameters are accurately defined by the operator for a more exacting weight placement, therefore improving the likelihood of a single spin balance. Follow the procedures outlined below:

1. Program "P18" to activate the ALU-S mode, the display will read "Alu - S" for 1 second.
2. Extend the rim offset gauge arm and touch the position of the left weight position. See Figure 30. The display will read "d - l" on its right window and the distance reading on its left window. Return the rim offset gauge arm to the rest position.
3. The machine displays "d - 2". Move the parameter arm to the right weight position. See Figure 31. The computer will display the distance reading in the left window and "d-2" in the right window. Rim width is calculated from the difference of D1 and D2.
4. Spin the wheel. The display will read "ALU" during the spin cycle.
5. After spinning, the machine displays both the left and right plane imbalance weight and position with its color LEDs.
6. When the operator pulls out the rim offset gauge arm, the software displays left correction plane first. The left display shows the weight to be applied, the right display shows the distance the gauge arm has still to travel to get to the correction plane. A beep will sound if the correct position is reached, at the same time the right display will show "0". "--" means the gauge arm is over extended

The left plane correction weight will be applied first.

- Position the gauge arm correctly.
- Position the wheel in the weight position
- Apply the weight.

Return the gauge arm to its home position. Now the right plane correction weight will be applied.

- Position the gauge arm correctly.
- Position the wheel in the weight application position
- Apply the weight.

"Homing" the gauge arm lets it toggle between left and right correction plane. To exit this mode press any mode key or Cancel"

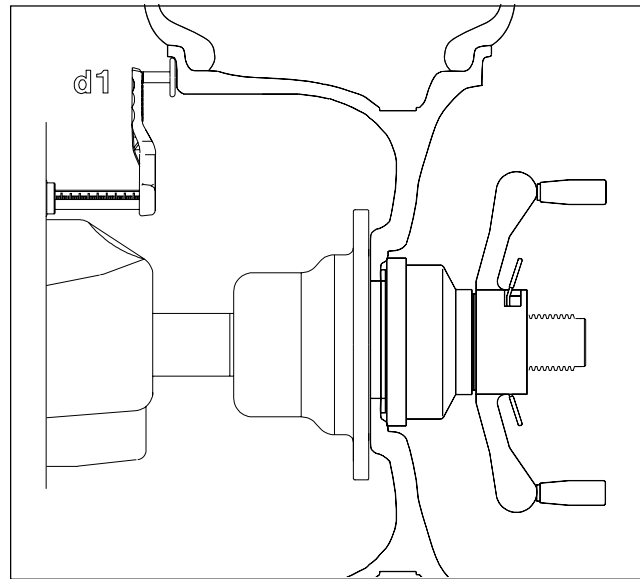

Figure 30

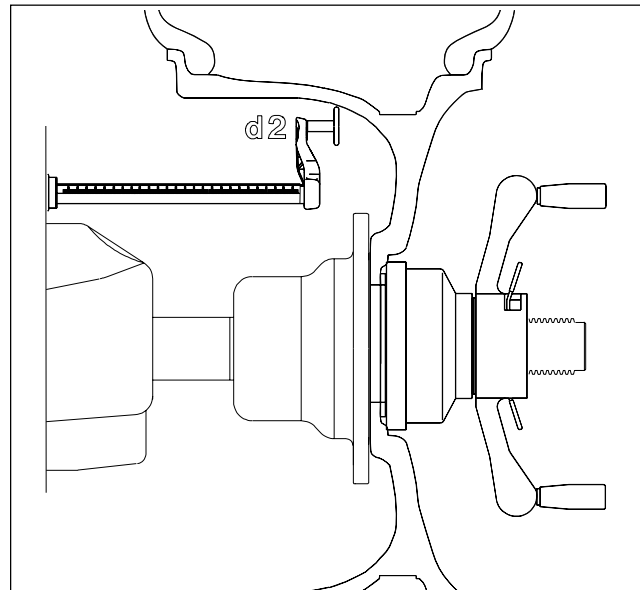

Figure 31

NOTE: To exit ALU-S mode and return to two plane DYN (dynamic) mode press "Mode" button. The machine displays "ALU OFF" for one second and then enters idle state with DYN mode

NOTE: Inspect the rim and available weights and use good judgement in your selection. Weights should not interfere with any suspension parts or make contact during rotation. If a weight does make contact, use an alternate location and select an appropriate mode.

8.0 USER CALIBRATION - P14

The Hand Spin Balancer features a calibration verification program which requires only a few minutes to complete. Perform this procedure to verify calibration when the balancer has been moved, disturbed, or whenever accuracy is questioned. If the calibration process fails a service technician should be dispatched to perform a complete calibration.

Follow these 3 simple steps:

1. Activate Calibration. Press and hold the **P** button (#1 Fig 32) while turning the *Diameter/Function Knob* (#2 Fig 32) until the display reads "P" "14".

- Once P14 activates, the display will read "CAL" "GAN" for one second.
- The display will then read "SPN" "1".
- Mount a balanced wheel/tire to the shaft. See Fig 33.

2. Spin shaft with balanced wheel only.

- Spin shaft CW, when standing in front of wheel.
- Displays "SPN" "UP" when shaft reaches 60 rpm.
- Displays "COA" "ST" with a beep if shaft speed has exceeded 120 rpm and will continue until speed drops to 119 rpm.
- Displays "CAL" "1" when the speed drops to 119 rpm. The machine is taking data and doing calculations. After taking data, shaft is automatically braked to a stopped.
- Displays "SPN" "2" when shaft stops.

3. Spin shaft with calibration slug on the left side.

Mount calibration slug to shaft. See Fig 34.

- Displays "SPN" "UP" when shaft reaches 60 rpm.
- Displays "COA" "ST" with a beep if shaft speed has exceeded 120 rpm and will continue until speed drops to 119 rpm.
- Displays "CAL" "2" when the speed drop down to 119 rpm. At this moment the machine is taking data and doing calculation work. After taking data, shaft is automatically stopped.
- Displays "CAL" "FIN" when the second step of calibration is finished and machine says the calibration result is *FINE*.
- Displays "Err" "C__" when shaft stops and machine is in the idle state.

NOTE: The balancer will not function until a valid calibration has been performed. Error messages would be displayed in the event problems occur during the calibration process. If problems occur contact an Authorized Service Representative.

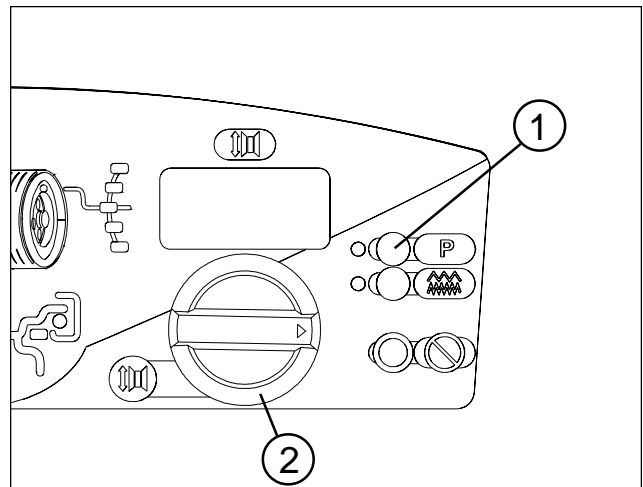

Figure 32

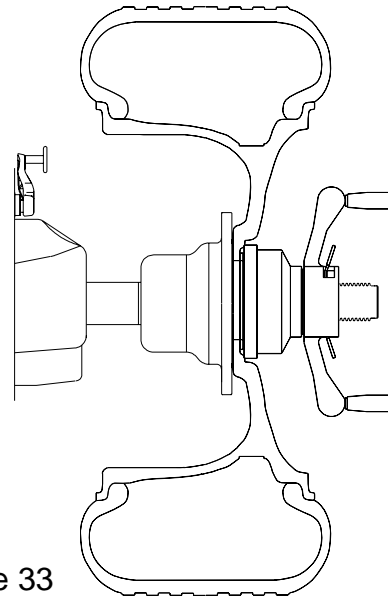

Figure 33

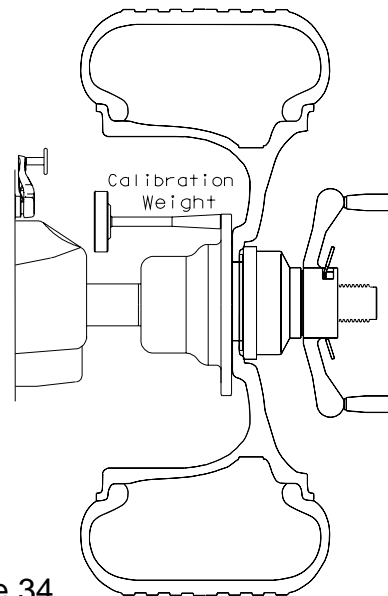

Figure 34

9.0 RIM OFFSET GAUGE CALIBRATION - P80

To recalibrate the Rim Offset gauge proceed as follows:

1. Make sure the Rim Offset Gauge Arm is at home position and no wheel is mounted to the shaft as shown in Figure 35.

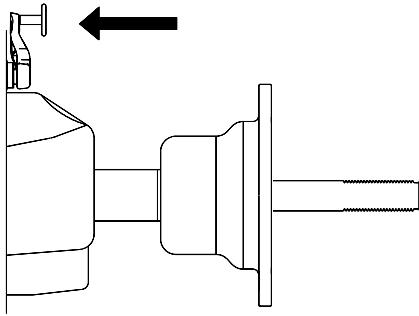

Figure 35

2. Activate the gauge calibration program, "P 80" by pressing and holding P button and turn diameter/function knob until 80 is displayed on right display window.

3. The right display will read "CAL SAP" for one second. This means CALibration SAPE. Then it displays "SAP OUT". The SAPE calibration procedure is activated.

4. Gently pull the SAPE arm OUT until it is fully extended, Figure 36, hold it steady for about 1 second.

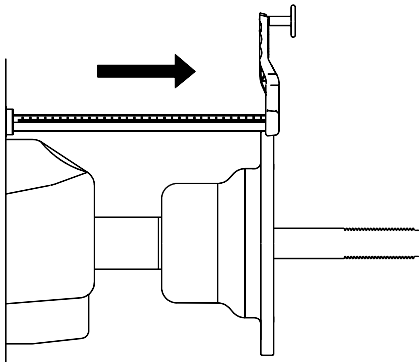

Figure 36

5. The display will now read "H POS" with a short beep sound. This is a reminder to return the arm back to its Home POSition.

6. Once the Rim Offset Gauge Arm is returned to its home position, machine displays "GOOD" with a confirmation beep. The calibration is finished.

10.0 EXPLANATION OF PROGRAM CODES

The wheel balancer microprocessor can be programmed for various functions and features. These programs are referred to as "P Codes". Activate the "P Code" programs by pressing and holding the **P** button while turning the right knob until the desired number is displayed on the right display window. User Codes are explained as follows:

- P3 Toggle switch between gram and ounce display
- P7 Toggle switch of millimeter and inch for diameter measurement
- P12 The balancer has 4 counters that keeps track of total number of cycles for a certain parameter. The balancer will automatically cycle through the counters after P12 is pressed. The order of the counters are:
 1. Display "**Ctr ALL**" for one second. Counter number of all spins.
 2. Display "**Ctr CAL**" for one second. Counter number of spins since last calibration.
 3. Display "**Ctr SrV**" for one second. Counter number of service spins.
 4. Display "**Ctr USR**" for one second. Counter number of user spins.
- P14 Shaft Calibration verification
- P18 ALU-S mode (press balancing mode key to exit and back to DYN mode)
- P44 Read or reset productivity of user. Display counter number of default user only.
- P80 Rim Offset Gauge Calibration
- P90 Tire Matching mode
- P91 Optimization

11.0 MAINTENANCE

BEFORE ANY MAINTENANCE OR REPAIRS ARE ATTEMPTED THE MACHINE MUST BE DISCONNECTED FROM THE ELECTRIC SUPPLY.

This balancer does not require any special maintenance, but the following precautions are required:

- A. Periodically wash all plastic parts with a glass cleaner. Wipe with a dry cloth.
- B. Clean all adapters regularly with a nonflammable liquid detergent all adaptors. Lubricate with a thin layer of oil.

12.0 TROUBLE SHOOTING

TROUBLE

When turning the machine on, the displays do not light

CAUSE

No electric power
Battery is discharged
Defect in the electric/electronic system

REMEDY

Check the input voltage
Charge the Battery
Call your authorized service center for assistance

The machine gives random readouts.

Machine unstable on the floor
Water in the tire
Loose adaptor
Defective electronic board

Check that machine is stable
Remove water from tire.
Tighten the adaptor firmly
Call your service center for assistance

The machine does not stop after balancing cycle

Defective electronic component

Stop using the machine immediately and call your authorized service center for assistance.

The balancer is slow to display when powering machine up.

This machine performs a self-test routine on start-up. There will be a delay of several seconds before the display is activated.

This is a normal characteristic of the machine

**Equipment Services
309 Exchange Ave
Conway, AR 72032**

**For Service Call:
1-800-225-5786**

Notice: The information contained in this document is subject to change without notice. Snap-on Incorporated makes no warranty with regard to this material. Snap-on Incorporated shall not be liable for errors contained herein or for incidental consequential damages in connection with furnishings, performance, or use of this material.

This document contains proprietary information which is protected by copyright and patents. All rights are reserved. No part of this document may be photocopied, reproduced, or translated without prior written consent of Snap-on Incorporated.