

***OPTIMA II***  
***WHEEL BALANCER***



***Parts Manual***

All information contained or disclosed in this document is considered confidential and proprietary by Snap-on Equipment. All manufacturing, use, reproduction, and sales rights are reserved by Snap-on Equipment and the information contained herein shall not be used in whole or in part without the express written consent of Snap-on Equipment.

# Table of Contents

BALANCER ASSEMBLY .....	4
REAR CAMERA ASSEMBLY LEFT/RIGHT .....	6
INSIDE SCANNER ASSEMBLY .....	7
WHEEL GUARD ASSEMBLY .....	8
BACK PACK ASSEMBLY .....	10
REAR SCANNER ASSEMBLY .....	12
SAPE ASSEMBLY .....	14
FOOT PEDAL ASSEMBLY .....	16
VIBRATORY ASSEMBLY (POWER CLAMP) .....	17



BOM

REQ	ITEM	PART NUMBER	DESCRIPTION
1	1	00058839000	TOOL-PDQ WEIGHT
2	2	00085767000	PAD-FOAM
1	3	00089209000	CORD-POWER ADAPTER 12
1	5	1-02815A	SCREW-HH LAG 5/16 X 3
2	6	1-5433	NUT & L/WASHER ASSY 5/16-18
3	7	1-2541	WASHER - FLAT, 5/16
1	9	3-02309A	MODULE FLASH 44 PIN
1	11	3-03708A	MONITOR-LCD 17W
2	13	1-1115	BOLT-HEX 5/16-18X3 UNC 2A TAP
1	16	EAA0247G21A	CALIPER-RIM WIDTH
1	17	EAA0307G54A	ACCY KIT-PWR CLAMP
1	18	EAA0369J19A	BALANCER ASSY - OPTIMA II
4	19	EAC0060G02A	FLANGE-COVER, ACCESSORY
1	20	EAK0221J92A	KIT-PRINTER M2 CABINET
1	21	EAL0341J44A	LABEL - ATTENTION - MAX WEIGHT
1	22	EAL0341J56A	LABEL-LASER
1	23	EAL0341J57A	LABEL-CAUTION
1	24	EAL0341J63A	LABEL-PATENT
1	25	EAL0341J70A	LABEL - LASER APERATURE
1	26	EAL0341J71A	LABEL - CFR CERTIFICATION
1	27	EAL0341J96A	LABEL - BALANCER WARING, REAR
1	28	EAL0341J97A	LABEL - BALANCER WARING, SIDE
1	29	EAL0343J76A	LABEL-ELECTRICAL/SERIAL
5	30	EAL0349G87A	LABEL-WHEEL #1
5	31	EAL0349G88A	LABEL-WHEEL #2
5	32	EAL0349G89A	LABEL-WHEEL #3
5	33	EAL0349G90A	LABEL-WHEEL #4
5	34	EAL0349G91A	LABEL-WHEEL #5
1	35	EAL0392J89A	LABEL-CUST SERV JBC
3	36	EAL0412G63A	LABEL - 2M CLASS LASER
1	38	EAL0412G51A	DECAL- OPTIMA II
1	39	EAM0005D40A	CALIBRATION WEIGHT
4	40	EAM0006G01A	HOOK-ACCESSORY STORAGE
1	41	EAX0039J02A	CORD-POWER 230V PIGTAIL
1	44	ZEEWB546B9	LIT PACK- BFH 2000
1	45	3-02615A	DRIVE-USB FLASH 4 GB
3	46	1-18159B	BOLT-ANCHOR 3/8-16 X 3

BALANCER ASSEMBLY  
EAA0369J08A

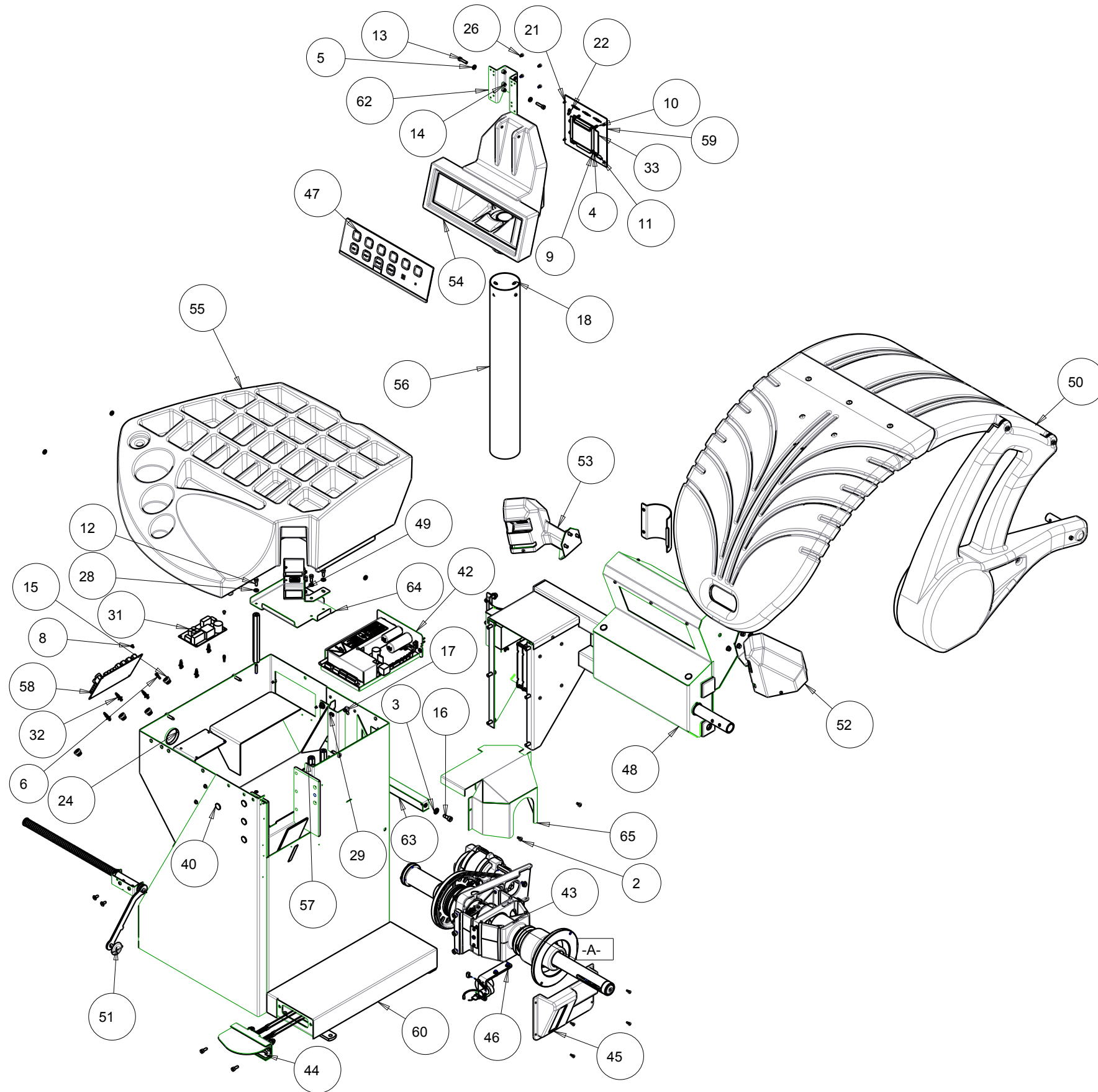

SYM	REQ	PART NO	DESCRIPTION				
1	8	EAS2116G12A	SPACER - VIB 0.2MM	47	1	EAA0364G98A	KEYPAD - NEUTRAL GREY W/ SLIDER
2	2	1-07824A	SCREW - SELF-TAPPING (M5 X 10 MM) ZINC (A2J)	48	1	EAA0369J20A	ASSY - OPTIMA 2 BACK PACK
3	2	1-10041	WASHER D.8 UNI6592-69/DIN125	49	1	EAA0369J22A	ASSY - INSIDE SCANNER
4	3	1-11233	NUT - HEX, M3 DIN 934	50	1	EAA0369J23A	ASSY - WHEEL GUARD
5	5	1-11744A	WASHER - NYLON FLAT	51	1	EAA0369J24A	SAPE - 2000 / OPTIMA 2
6	2	1-11961A	STANDOFF - HEX M4 X 10	52	1	EAA0369J25A	ASSY - REAR RIGHT CAMERA
7	1	1-1248	WASHER SHAKE PROOF, M3	53	1	EAA0369J26A	ASSY - REAR LEFT CAMERA
8	2	1-13606A	SCREW-PHMS,M4 X 6MM W/ LOCKWASHER	54	1	EAC0094G36A	MONITOR AND KEYBOARD SUPP.
9	2	1-14661A	HEX METAL SPACER M3X15MM M/F NICKEL	55	1	EAC0099G60A	WEIGHT TRAY -SOL
10	2	1-14761A	HEX METAL SPACER M3X15MM F/F NICKEL	56	1	EAM0050J49A	TOWER - BALANCER TUBE
11	2	1-16161A	HEX SPACER M/F 4-40 L=5MM	57	3	EAM0071G44A	HEXAGONAL SPACER
12	5	1-16309	SCREW - SHCS, M6 X 16MM,	58	1	EAP0271G60A	CAMERA AND HUB USB
13	2	1-16509A1	SCREW - SHCS, M6 X 25MM, BLK	59	1	EAS2097G95A	SUPPORT PLATE FOR
14	9	1-17559A	NUTSERT - M6	60	1	EAA0369J32A	CABINET ASSY - M2, RED
15	4	1-17659A	THREADED INSERT M10X22		1	EAA0369J33A	CABINET -BALANCER M2 US BLUE
16	2	1-17709	SCREW - SHCS M8 X 20MM	62	1	EAS2113J55A	BRACKET - MONITOR MOUNT
17	8	1-18359A	THREADED INSERT M8X1,25	63	1	EAS2118J62A	STIFFENING - M2 CABINET
18	4	1-18523A1	SELF TAPPING SCREW D4,8X13MM	64	1	EAS2118J64A	BRACKET - INNER SCANNER
19	3	1-03725A	SCREW-PH SELF TAP M6.3X32 PHIL	65	1	EAS2128J19A	WELDMENT - VIB COVER,
21	4	1-20423	SCREW, SELF TAPPING M4.2 X 13MM	66	1	EAW0240G86A	CABLE ASM- STOP,
22	5	1-20504A	SCREW PAN HEAD	67	1	EAW0276G22A	CABLE ASM- STOP SHORT,
24	1	1-2676	PLUG-HOLE, 2"DIA	68	1	EAW0276G24A	CABLE ASM - STEPPER MOTOR,
25	2	1-3724	SCREW-SELF TAP,5 X 10MM	69	1	EAW0276G28A	LASER - POINTER EXTENSION WIRE
26	4	1-46809	SCREW-HEX SOCKET HEAD CAP M4X6 8.8 -A2J	70	1	EAW0276G29A	CABLE ASM - STEPPER MOTOR,
27	3	1-51910A	SCREW STEI 6X30 12K	71	1	EAW0276G31A	WIRING HARNESS -
28	3	1-9841	WASHER PLAIN, 6MM	72	1	EAW0276G51A	CABLE ASM - AWP ENCODER
29	1	2-23201	TERMINAL LUG-6.3MM X .8MM POP RIVET	73	1	EAW0277G05A	MAIN CORD MONITOR AND SWITCH
30	1	2-28301A	GROUND CONNECTOR	74	1	EAW0233J50A	CABLE - POWER SUPPLY
31	1	2-48066A	12V POWER SUPPLY	75	1	EAM0071G52A	GLASS FOR LASER
32	6	2-732	SUPPORT PCB LOCKING	76	1	5-10540A	DOUBLE SIDES ACRYLIC FOAM TAPE
33	1	3-05009A	EMBEDDED-PC KIT PCM3353F-1GB RAM				
34	1	3-60826AF1	MEMORY CARD PROG EPC NEW GUI				
35	2	6-08722A	USB 2 CABLE, A-MINIB 2M				
36	3	6-08822A	USB 2 CABLE, A-MINIB 1.5M				
37	1	6-09122A	USB 2 CABLE, A-B 2M				
38	1	6-09922A	PATCH CABLE FTP 2M				
39	4	6-10022A	PATCH FLAT CABLE UTP				
40	4	8-7216	PLUG-HOLE, 16MM DIA				
42	1	EAA0338G83B	ASSY - IBP DIGITAL BOX				
43	1	EAA0363G57A	ALU. OPTIMA VIBRATORY SYSTEM				
44	1	EAA0346J82A	ASSY - FOOT PEDAL POWER CLAMP				
45	1	EAA0358G03A	LASER POINTER				
46	1	EAA0358G04A	ASSY LASER				

# REAR CAMERA ASSEMBLY LEFT/RIGHT

EAA0369J26A - LEFT

EAA0369J25A - RIGHT

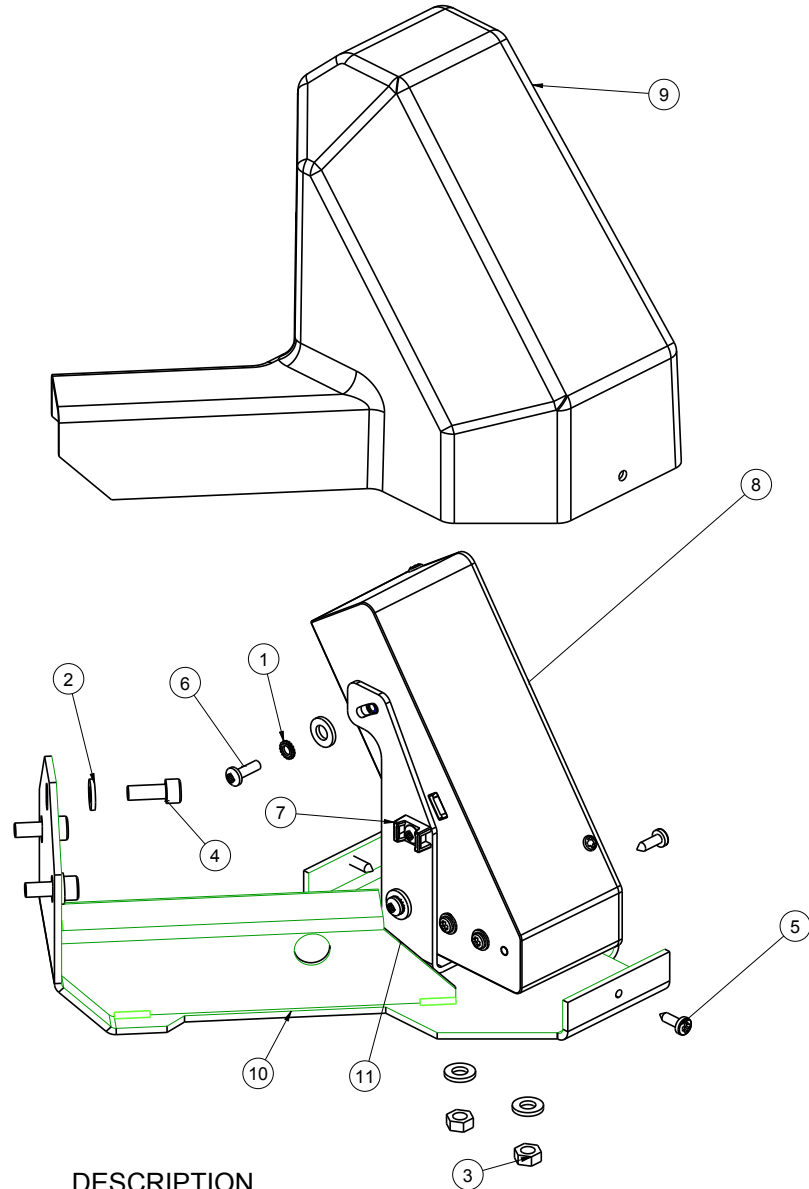

SYM	REQ	PART NO	DESCRIPTION
1	3	1-1348	LOCKWASHER D4
2	7	1-9841	WASHER PLAIN, 6mm
3	2	1-9933	M6 NUT, ZINC
4	3	1-16309	SCREW - SHCS, M6 X 16mm,
5	3	1-22623A	SELF-TAPPING SCREW TCB
6	3	1-24606A	SCREW-PHMS,M4 X .7MM X 12MM
7	1	5-07945A	FLAT TIE HOLDER FTH-13R
8	1	EAA0345G77A	SHEET OF LIGHT MODULE
9	1	EAC0100G27A	COVER FOR REAR LEFT
	1	EAC0099G67A	COVER FOR REAR RIGHT
10	1	EAS2116G99A	ASSY REAR LEFT CAMERA
	1	EAS2116G98A	ASSY REAR RIGHT CAMERA
11	1	EAS2128J03A	SUPPORT - COMPLETE INTERMEDIATE



INSIDE SCANNER ASSEMBLY  
EAA0369J22A

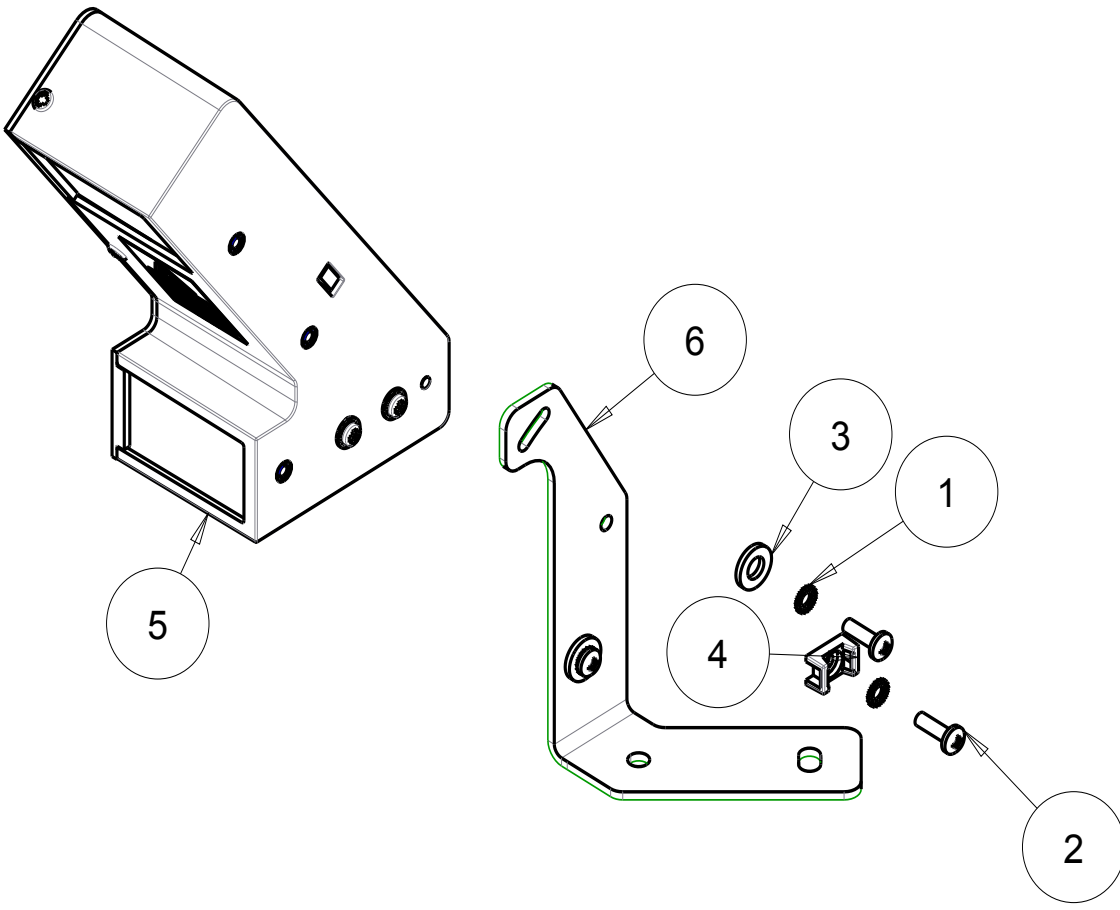

SYM	REQ	PART NO	DESCRIPTION
1	3	1-1348	LOCKWASHER D4
2	3	1-24606A	SCREW-PHMS,M4 X .7MM X 12MM
3	2	1-9841	WASHER PLAIN, 6mm
4	1	5-07945A	FLAT TIE HOLDER FTH-13R
5	1	EAA0345G77A	SHEET OF LIGHT MODULE
6	1	EAS2118J63A	SUPPORT - INNER SCANNER

WHEEL GUARD ASSEMBLY  
EAA0369J23A

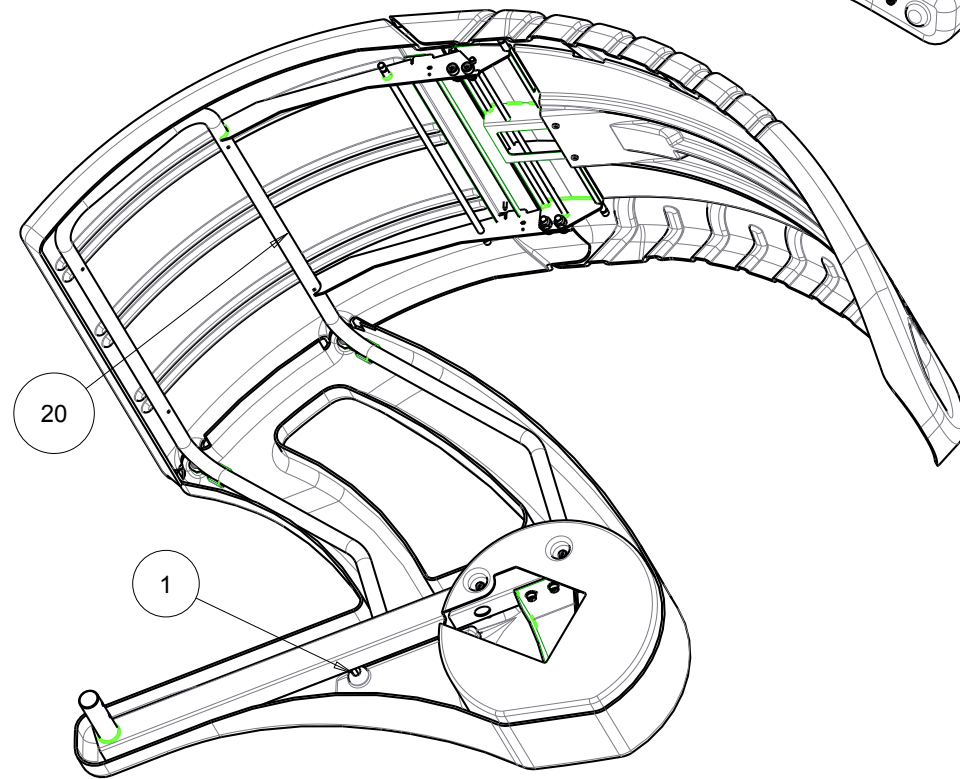
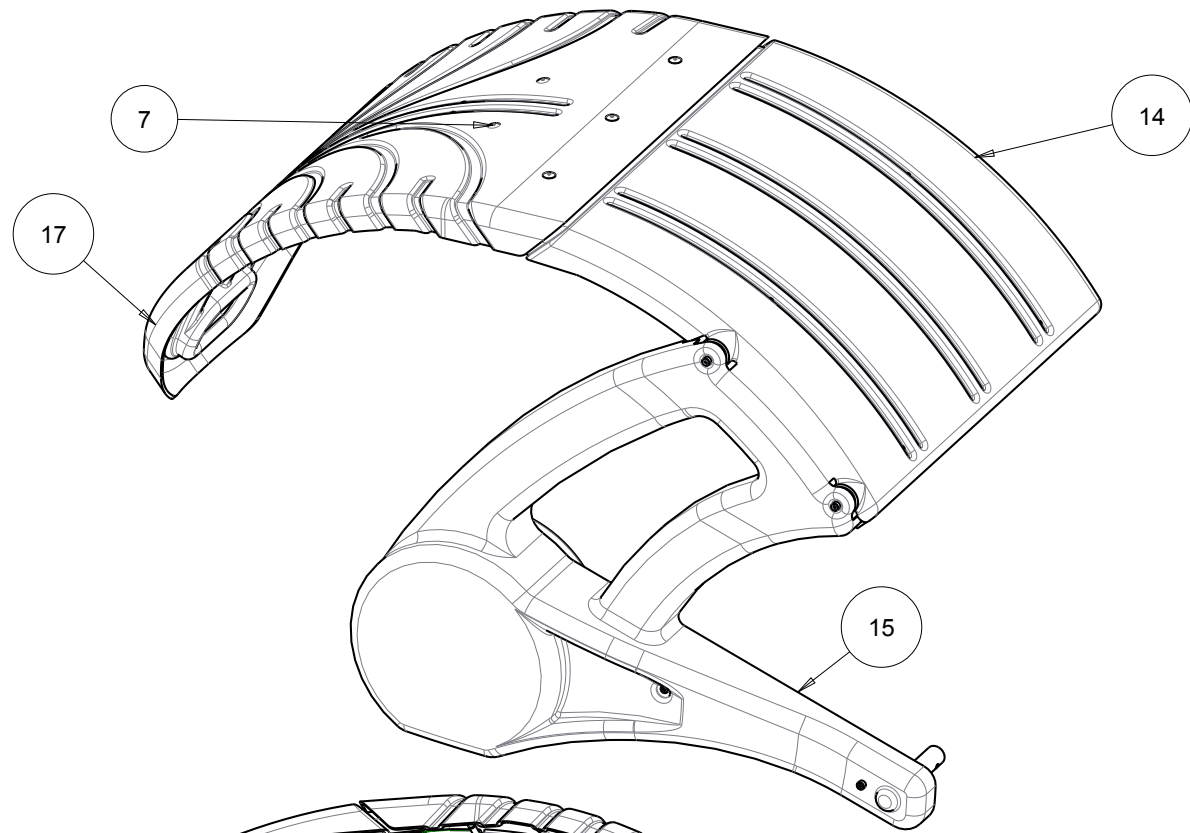
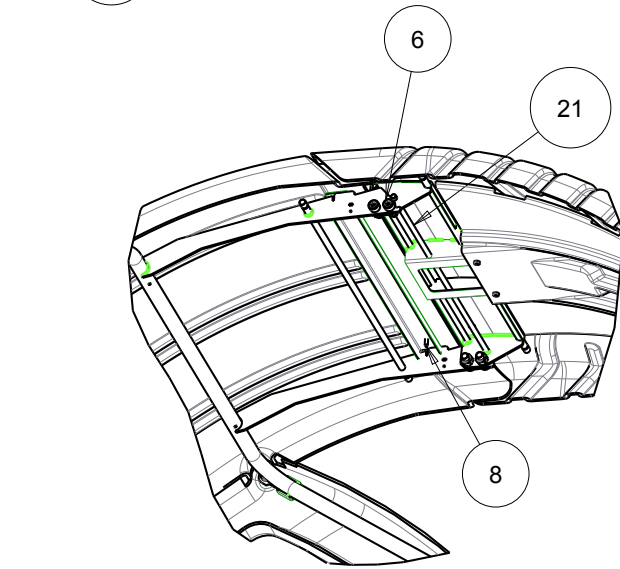
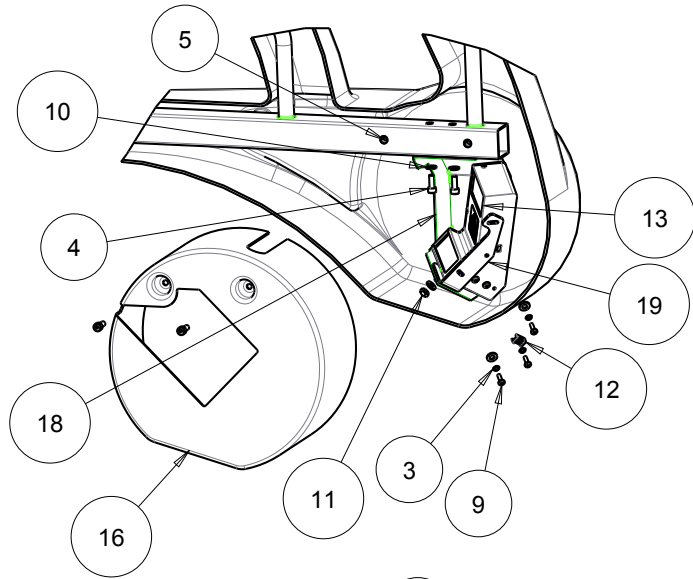

SYM	REQ	PART NO	DESCRIPTION
1	1	1-01915A	EXAG. SPACER M6x35
2	4	1-10033	NUT, HEX, M8
3	3	1-1348	LOCKWASHER D4
4	8	1-16309	SCREW - SHCS, M6 X 16mm,
5	8	1-17559A	NUTSERT - SELF CLINCH, M6 X 16,5mm
6	4	1-17709	SCREW - SHCS M8 X 20mm
7	5	1-18158A	RIVET 4,8x10
8	10	1-22623A	SELF-TAPPING SCREW TCB
9	3	1-24606A	SCREW-PHMS,M4 X .7MM X 12MM
10	6	1-9841	WASHER PLAIN, 6mm
11	2	1-9933	M6 NUT, ZINC
12	1	5-07945A	FLAT TIE HOLDER FTH-13R
13	1	EAA0345G77A	SHEET OF LIGHT MODULE
14	1	EAC0099G58A	BFH WHEEL GUARD
15	1	EAC0100G28A	BFH WHEEL GUARD
16	1	EAC0100G29A	BFH EXTERNAL SCANNER
17	1	EAM0075G17A	STIFFENED BFH
18	1	EAS2116G00A	ASSY EXT. CAMERA
19	1	EAS2128J03A	SUPPORT - COMPLETE INTERMEDIATE
20	1	EAS2128J05A	WHEELGUARD ASSY- BFH2000, LOWER
21	1	EAS2128J09A	WHEELGUARD ASSY- BFH 2000, TOP

BACK PACK ASSEMBLY  
EAA0369J20A

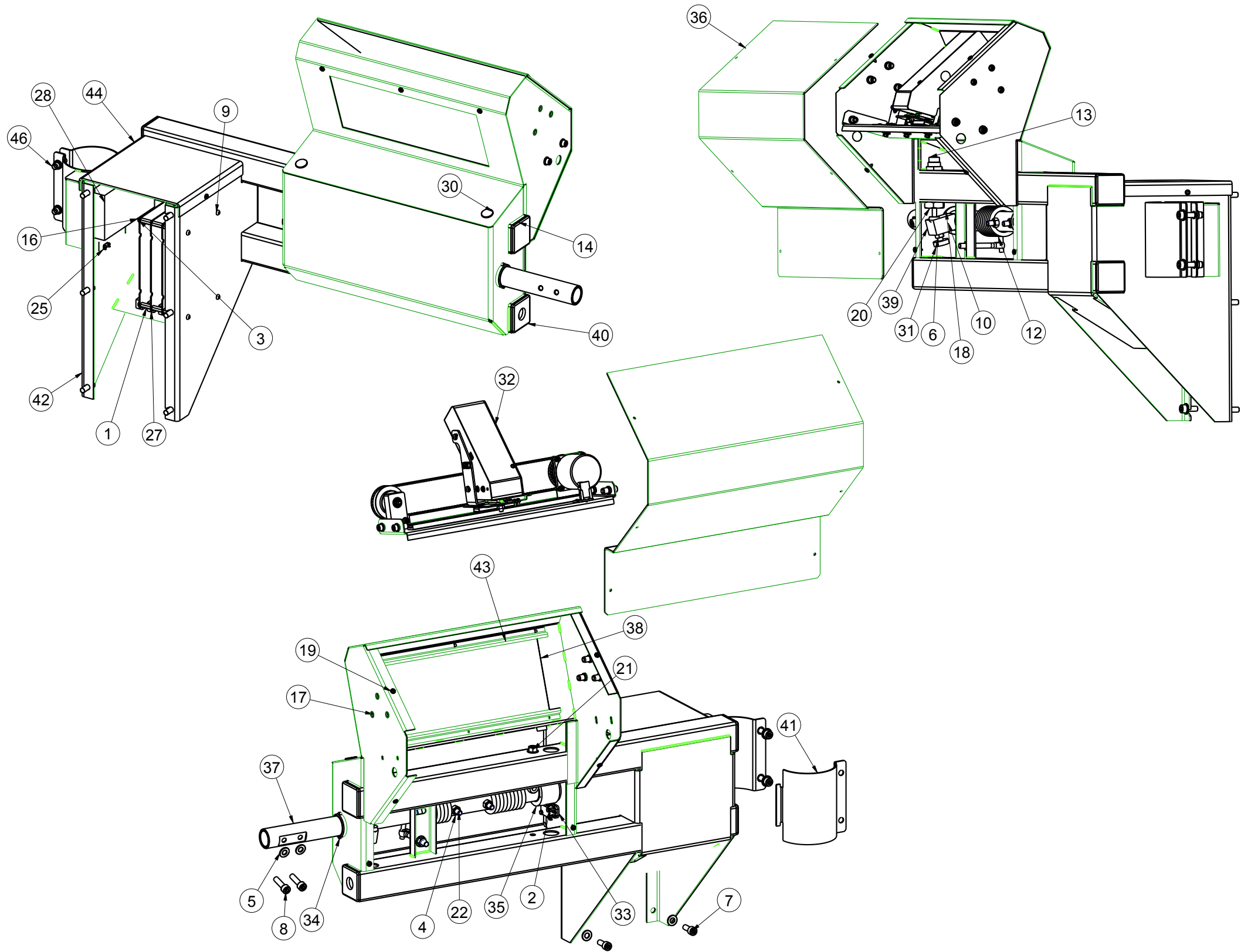

SYS	REQ	PART #	DESCRIPTION
1	16	1-02015	STANDOFF - HEX, M4 X 20MM F/F
2	2	1-9541	WASHER-FLAT,M3 DIN 125A
3	4	1-5547	WASHER-LOCK, EXT, M4
4	2	1-10033	NUT, HEX, M8
5	12	1-10041	WASHER D.8 UNI6592-69/DIN125
6	1	1-11733	NUT M8 6S STAND WHITE ZINC
7	6	1-17709	SCREW - SHCS M8 X 20mm
8	4	1-17909	SCREW-HHCS M8 X 30
9	4	1-19804	SCREW, PHIL PAN HEAD M4x6 *
10	1	1-20409	SCREW TCEI M12X35 12.9 BR
11	2	1-02330A	"EYE"-SCREW M8x70
12	2	1-04267A	SPRING-TORSION
13	1	1-04969A	SHOCK ABSORBER W NUT W CUP
14	3	1-11276A	50x50 SQUARE CAP
15	2	1-26901	SCREW,HEX HEAD MAC. M3X20 8.8 A2
16	4	1-11433A	NUT- M4X3,2mm THK, BLK
17	6	1-17559A	NUTSERT - SELF CLINCH, M6 X 16,5mm
18	1	1-22441A	SHIM RING 32X45X1
19	11	1-22623A	SELF-TAPPING SCREW TCB
20	1	1-22933A	NUT - MB 20X1.5 6S
21	2	1-23159A	6kt-Mutter M8 (DIN 6927)
22	2	1-24603A	SCREW M8x60 CLASSE 12.9
23	1	1-49010A	SCREW, SOCKET WITH CUP POINT M8X8
24	1	2-08861A	SWITCH-BASIC
25	1	2-23201	TERMINAL LUG-6.3MM X .8MM POP RIVET
27	4	3-05109A	EMBEDDED PC ALIX3D2
28	1	3-05209A	SWITCH ETHERNET 10/100 MBPS
29	4	3-64926AF1	PROGRAMMED - C FLASH WITH CAMERA EPC
30	2	8-7216	PLUG-HOLE, 16MM DIA
31	1	8-13518A	Bumper 25x7 /M8x23
32	1	EAA0369J21A	ASSY-REAR SCANNER, BFH
33	1	EAC0053J16A	MICROSWITCH PLATE
34	2	EAC0058D36A	WHEELGUARD BUSHING D.32
35	1	EAC0058D38A	Schaltring Switch Segment
36	1	EAC0099G44A	BFH REAR SCANNER
37	1	EAM0071G35A	BFH WHEEL GUARD
38	1	EAM0071G59A	GLASS FOR REAR
39	1	EAM0074G04A	BFH WHEEL GUARD
40	1	EAM0074G05A	MACHINED SQUARE
41	1	EAS2118J71A	CLAMP - PRINTER SUPPORT
42	1	EAS2118J84A	ASSY BFH BACK PACK
43	1	EAS2118J96A	GLASS SUPPORT
44	1	EAS2118J97A	COVER - BACK PACK, BFH 2000
45	1	EAW0233J23A	CABLE ASM - HOOD SWITCH
46	2	1-18359A	THREADED INSERT M8x1,25
47	1	5-03241A	"P" ADHESIVE SEAL
48	1	5-10426A1	TAPE-VELCRO 1" HOOK
49	1	5-10426A2	TAPE-VELCRO 1" LOOP

REAR SCANNER ASSEMBLY  
EAA0369J21A

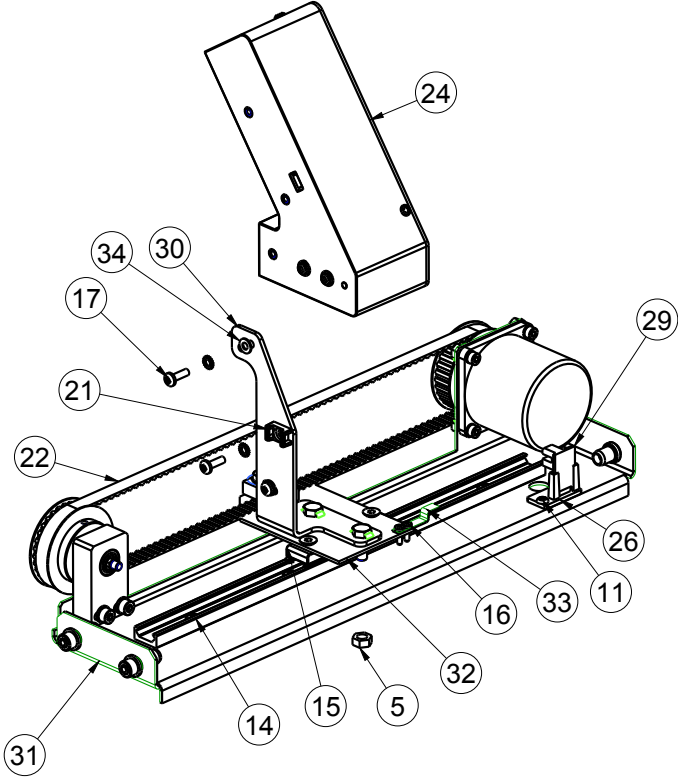
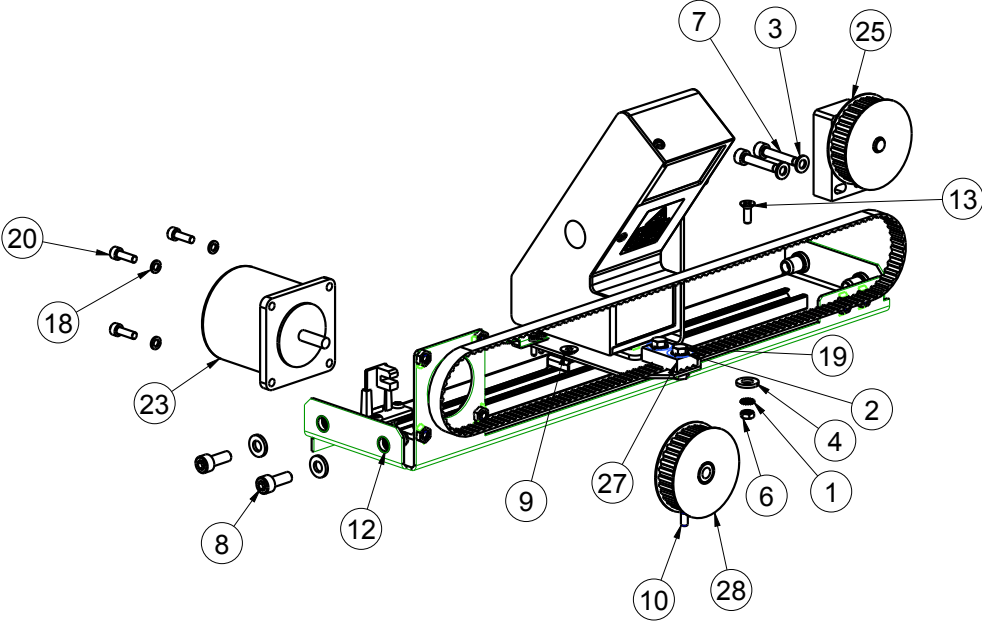

SYM	REQ	PART NO	DESCRIPTION
1	7	1-1348	LOCKWASHER D4
2	2	1-1448	WASHER - EXTER SHAKEPROOF D5
3	2	1-9741	WASHER-FLAT, M5 X 10.00D X 1MM THK
4	10	1-9841	WASHER PLAIN, 6mm
5	2	1-9933	M6 NUT, ZINC
6	4	1-11433	NUT - M4 6S
7	2	1-15209	SCREW - SHCS, M5 X 25mm, ZINC
8	4	1-16309	SCREW - SHCS, M6 X 16mm,
9	2	1-18503	SCREW TSEI 5x12 8.8
10	1	1-38910	SCREW M4X8SET CUP ZP
11	2	1-17023a	SHEETMETAL SCREW PHIL HEAD
12	4	1-17559A	NUTSERT - SELF CLINCH, M6 X 16,5mm
13	4	1-20603A	SCREW PH. 4x12 ZINC. UNI 7046 4.8
14	1	1-21284A	SLIDEWAYS ROLLON
15	1	1-21384A	SLIDING BLOCK
16	2	1-22723A	SCREW SELF TAP.
17	3	1-24606A	SCREW-PHMS,M4 X .7MM X 12MM
18	4	1-2546A	WASHER - SP LOC, 4mm X 0,9mm, BLK
19	2	1-46401A	SCREW,HEXAG M5X16 A2J DIN 933
20	4	1-52009A	SCREW, HEX SOCKET HEAD M4x12
21	1	5-07945A	FLAT TIE HOLDER FTH-13R
22	1	8-06631A	TOOTHED BELT T5
23	1	EAA0328G15A	STEPPER MOTOR BIG
24	1	EAA0345G77A	SHEET OF LIGHT MODULE
25	1	EAA0357G99A	BELT TIGHTENING
26	1	EAC0087G03A	BOARD SUPPORT FOR REAR SCANNER
27	1	EAM0048G47A	TOOTHED PLATE T5 MACHINED
28	1	EAM0076G50A	MACHINED ASSY PULLEY
29	1	EAP0167G10A	OPTO SWITCH BOARD
30	1	EAS2128J03A	SUPPORT - COMPLETE INTERMEDIATE
31	1	EAS2128J13A	SUPPORT - SCANNER REAR DRIVE
32	1	EAS2128J15A	SUPPORT - SCANNER, REAR ASSY
33	1	EAS2128J17A	STROKE END - REAR SCANNER
34	2	1-9641	PLAIN WASHER D4mm

SAPE ASSEMBLY  
EAA0369J24A

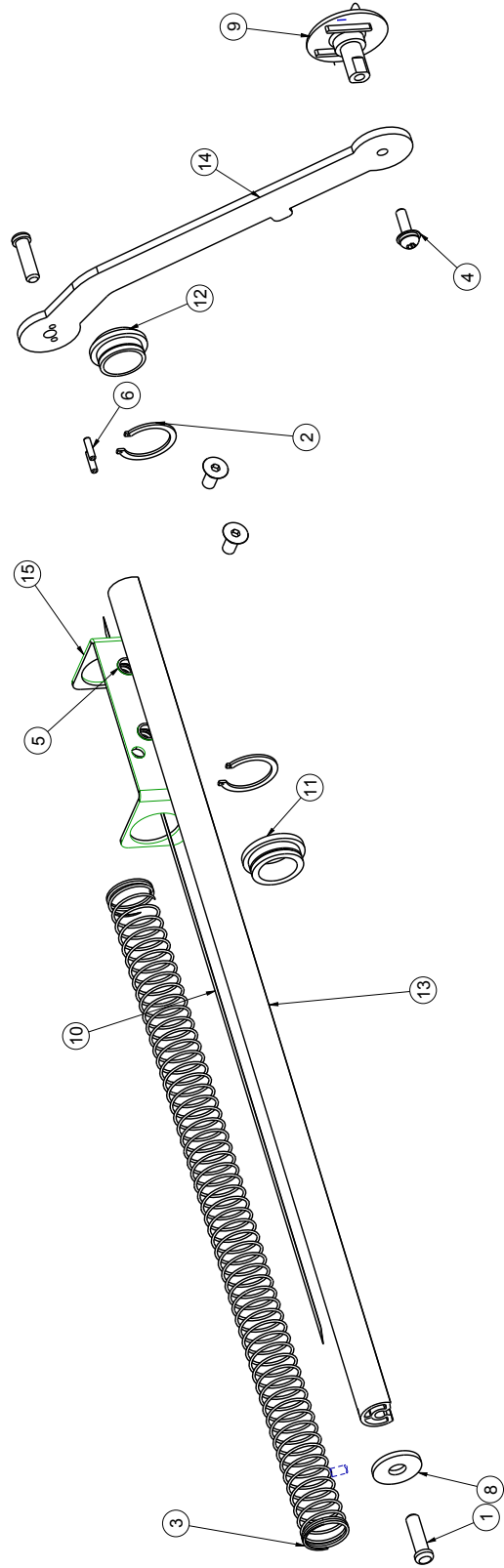



SYM	REQ	PART NO	DESCRIPTION
15	1	EAS2128J18A	SUPPORT - CALIPER ROD
14	1	EAM0071G38A	BFH ARM FOR
13	1	EAM0053G08A	STANDARD. ROD SAPE, TRUCK
12	1	EAM0005D39A	BUSHING- OUTER SAPE ROD
11	1	EAM0005D38A	BUSHING-INNER SAPE ROD
10	1	EAL0349G31A	DISTANCE SCALE
9	1	EAC0058D11A	DISK-TOUCHING
8	1	1-17841	WASHER - D. 8X24
7	2	1-27903A	SCREW - M6 X 14MM FHMS, SKT DIN 7991
6	2	1-19552A	DOWELL PIN
5	2	1-17559A	NUTSERT - SELF CLINCH, M6 X 16,5MM
4	1	1-11926A	SELF TAP. SCREW PT WN1411 5X16 FL. ZINC
3	1	1-10468A	GAUGE SPRING
2	2	1-4577	RING-SNAP,25 X 1.20
1	2	1-3824	SCREW-SELF TAP,6 X 12MM

FOOT PEDAL ASSEMBLY  
EAA0369J82A

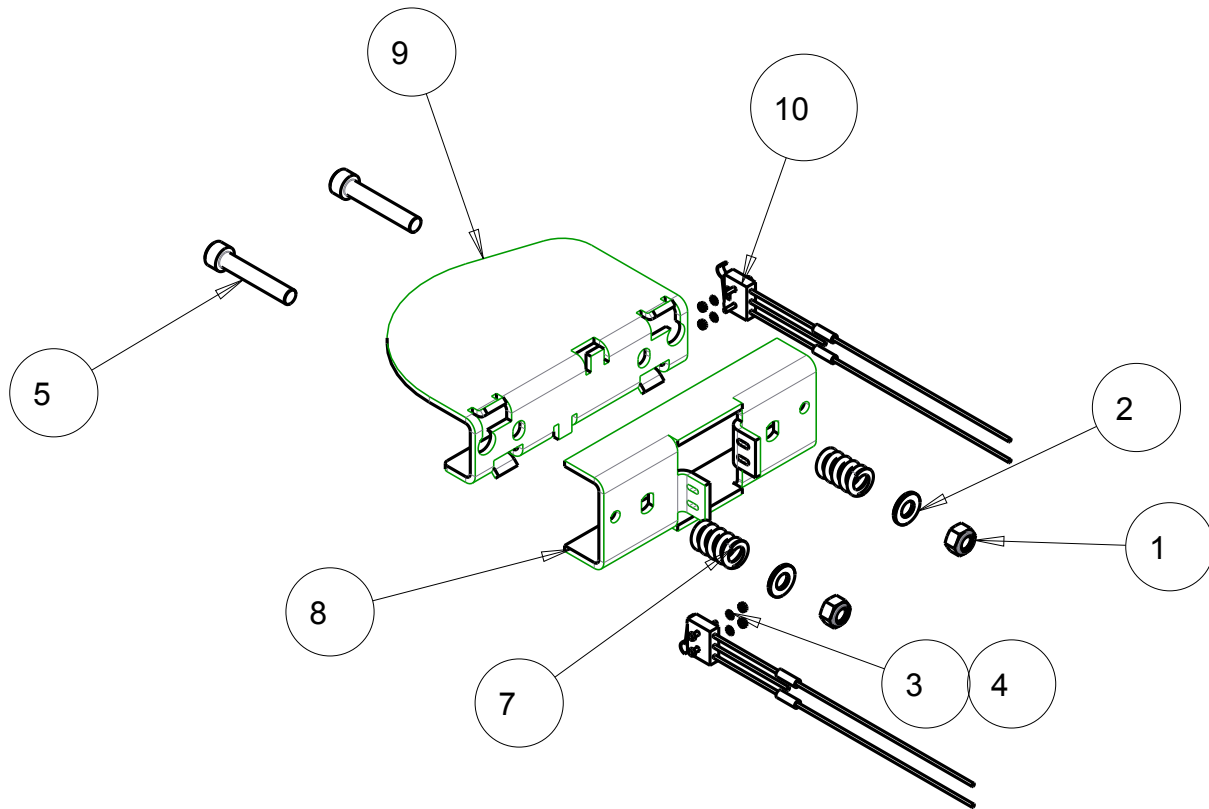

SYM	REQ	PART NO	DESCRIPTION
1	2	1-10033	NUT, HEX, M8
2	2	1-10041	WASHER D.8 UNI6592-69/DIN125
3	4	1-1048	WASHER, EXTERNAL SHAKEPROOF D2
4	4	1-11033	NUT - HEX, M2
5	2	1-18209	SHCS-M8 X 45
6	4	1-36606A	SCREW - M2 X 16MM, PAN HEAD PH ZINC
7	2	1-6668	COMPRESSION SPRING
8	1	EAS2113J93A	SUPPORT - BRAKE PEDAL
9	1	EAS2113J94A	FOOT PEDAL
10	2	EAW0233J46A	SWITCH ASSY - PC FOOTPEDAL

# VIBRATORY ASSEMBLY (POWER CLAMP)

EAA0363G57A

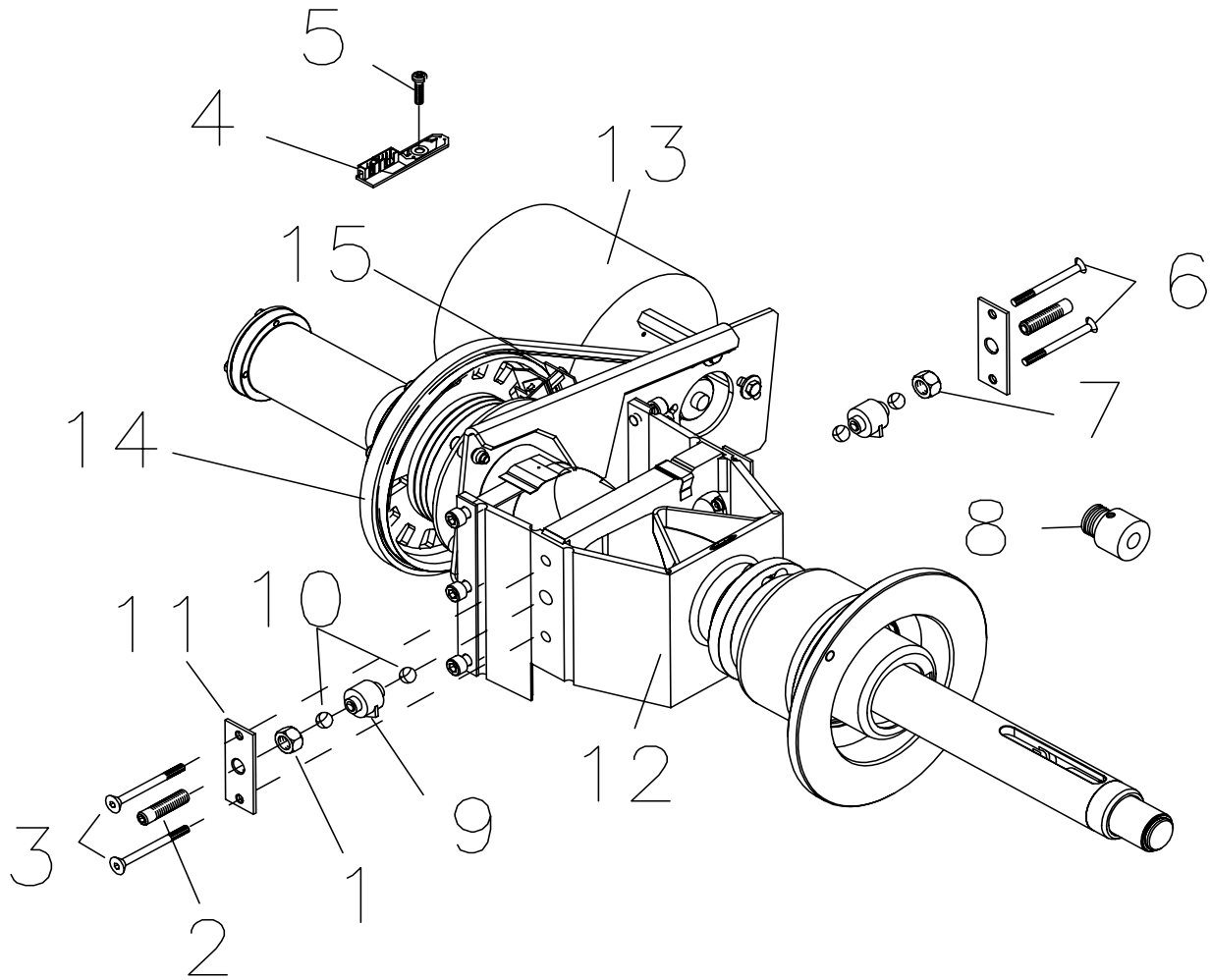

REF	QTY	PART NUMBER	DESCRIPTION
1	1	1-11833	NUT-HEX M 10 X 1 DIN 934
2	2	EAM0005D07A	SETSCREW - HEX SOCKET M 10 X 1
3	2	1-19903A	SCREW HEX SOCKET / COUNTERSUNK M 4 X 65
4	1	EAA0344G00A	ENCODER PCB
5	1	1-13004	SCREW PHILLIP PAN HD M 4 X 6
6	2	1-17403	SCREW HEX SOCKET / COUNTERSUNK M 4 X 25
7	1	1-4034	NUT - HEX M 10 X 1 DIN 439
8	1	EAM0005D08A	PULLEY SMALL
9	1	EAA0260D59A	TRANSDUCER
10	4	8-1144	BALL, STEEL
11	2	1-2967	PRETENSION SPRING
12	1	EAA0344G06A	VIBRATOR ASS'Y-MOTORIZED
13	1	EAA0266D29A	MOTOR 230V/50-60HZ
14	1	8-3531	MULTIRIB BELT 5 PJ 711 DIN 7867
15	1	EAP0201D20A	POWER CLAMP ENCODER
*	1	EAW0239D00A	RIBBON CABLE VIBRATORY







309 Exchange Ave.  
Conway, AR 72032  
501-450-1500

Notice: The information contained in this document is subject to change without notice. Sapon Equipment makes no warranty with regard to this material. Sapon Equipment shall not be liable for errors contained herein or for incidental consequential damages in connection with furnishings, performance, or use of this material.

This document contains proprietary information which is protected by copyright and patents. All rights are reserved. No part of this document may be photocopied, reproduced, or translated without prior written consent of Sapon Equipment.