

Spare Parts Pieces de Rechange Ersatzteilliste Запасные части
Tavole ricambi Tabla de Repuestos Figuras das Pecas

JohnBean™



B300

- (**GB**): in a given list, components sharing the same letter (A,B,C...), in the “Note” column are compatible.
- (**FR**): dans une table, les composants qui présentent la même lettre (A,B,C...) dans la colonne “Note”, sont compatibles.
- (**DE**): Die in einer Tabelle aufgeführten Komponenten, die in der Spalte “Anmerkung” mit demselben Buchstaben (A,B, C...) gekennzeichnet sind, sind kompatibel.
- (**RU**): В данном списке компоненты с одинаковыми буквами (А, В, С) в графе “Примечания” совместимы.
- (**IT**): all’interno di una tabella, i componenti che presentano la medesima lettera (A,B,C...) nella colonna “Nota”, sono compatibili.
- (**ES**): dentro de una tabla, los componentes de la columna “Nota” que poseen la misma letra (A, B, C...) son compatibles.
- (**PT**): em uma determinada tabela, os componentes que apresentarem a mesma letra (A,B,C...) na coluna “Nota”, são compatíveis.]

INDEX		Page
EAZ0070G62A_A2	CABINET	4
EAZ0070G56A_C3	WEIGHT TRAY AND DIGITAL PANEL	7
EAZ0070G57A_B	WHEEL GUARD SUPPORT	9
EAZ0136G42A_B	SAPE 2D ASSEMBLY	12
EAZ0070G64A_1	ALU VIBRATORY SYSTEM INT.FLANGE	15
EAZ0033G88A_C	VIBRATORY SYSTEM	18
EAZ0070G58A_A2	LASER POINTER	21
EAZ0070G61A_B	WHEELGUARD AND SONAR	23
EAZ0088G23A	PEDAL ASSEMBLY	25
EAZ0089G37A_E	PEDAL P-CLAMP UL	27
EAZ0033G99A_B	PEDAL P-CLAMP	29
EAZ0088G91A_B	INTEGRATED DISPLAY PANEL	31
EAZ0088G92A_D1	POWER INLET ASSEMBLY	33
EAZ0088G16A_A1	MID-RANGE ACCESSORY BOX	35
EAZ0070G83A_1	POWER CLAMP ACCESSORIES	37
EEWB559AWD_C1	WIRING DIAGRAM	40
EEWB559AWD_C2	WIRING DIAGRAM	41
EEWB559APWD_C1	WIRING DIAGRAM	42
EEWB559APWD_C2	WIRING DIAGRAM	43
EEWBB573AWD_A	WIRING DIAGRAM	44

UPDATING GUIDE:

Oct. 20: EAZ0089G37A_D > EAZ0089G37A_E

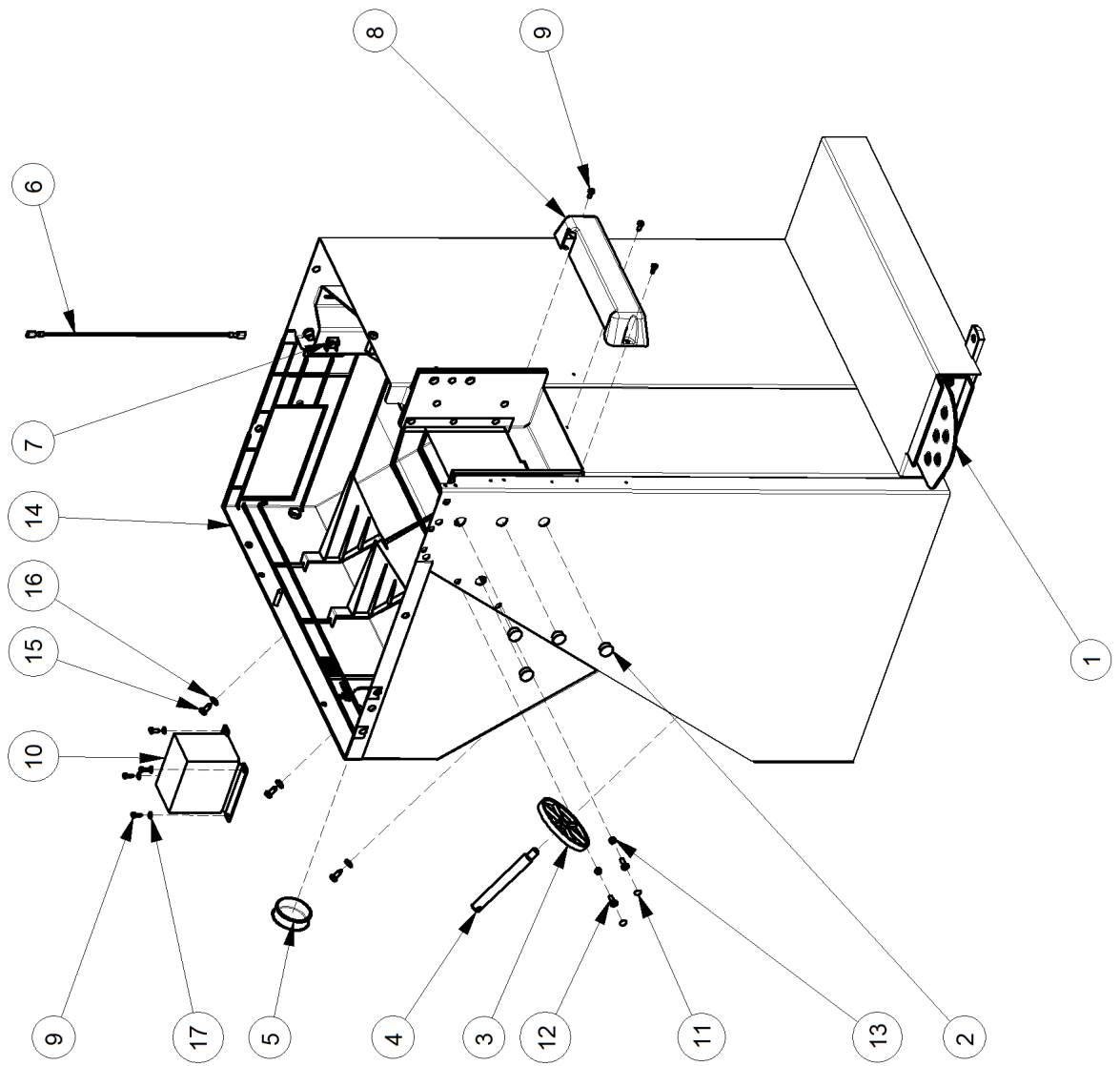

Pos	Code	Designation Designazione ОПИСАНИЕ	Désignation Designación Benämning	Bezeichnung Designação	N.	Note Nota HOTa	A	B	C
1	EAA0332G26A	p version Pedal, 2 switch Pedale per versione "p", 2 interruptori ПЕДАЛЬ ТОРМОЗА В СБОРЕ	Pédale de version "p", 2 contact Pedal "p", 2 conmutador	Pedal "p", 2 schalter Pedal na versão de "p", 2 interruptor	1		X		
1	EAA0263G07A	J-TYPE BRAKE PEDAL GRUPPO PEDALE FRENO J ПЕДАЛЬ ТОРМОЗА	GROUPE PEDALE FREIN J GRUPO PEDAL FRENO J	PEDALGRUPPE J-STYLE PEDAL TRAVÃO J	1		X		X
1	EAA0372G98A	ALU BRAKE PEDAL 2 SWITCHES PEDALE FRENO ALLUMINIO 2 MICRO ПЕДАЛЬ АЛУ 2 ПОЛОЖЕНИЯ	PEDALE FREIN ALUMINIUM 2 MICRO PEDAL FRENO ALUMINIO 2 MICRO	BREMSPEDAL ALUMINIUM 2 MIKRO PEDAL FREIO ALUMINIO 2 MICRO	1	POWER CLAMP	X		X
2	EAC0060G00A	VIBRATORY SYSTEM HOLES CUP TAPPO FORI GRUPPO MISURA ПРОБКА ДЛЯ ОТВЕРСТИЙ	BOUCHON, GROUPE MESURE TAPON-GRUPO MEDIDAS	ABDECKKAPPE 15,9 MM TAMPA FUROS	4		X		
3	EAC0060G02A	FLANGES PROTECTION PROTEZIONE FLANGE ЗАЩИТНЫЙ БУФЕР	PROTECTION FLASQUES PROTECCIÓN BRIDAS	FLANSCHSCHUTZ PROTEÇÃO FLANGE	4			X	
4	EAM0006G01A	FLANGE HOLDER PIN PERNO PORTA FLANGE КРОНШТЕЙН	AXE PORTE-FLASQUES PERNO PORTA BRIDAS	FLANSCHBOLZEN PINO PORTA-FLANGE	4			X	
5	1-10576A	BLACK COV. CAP FOR SHEETMETAL TAPPO NERO DI COP. PER LAMIERE ПЛАСТИКОВОЕ КОЛЬЦО	BOUCHON HABIL. NOIR POUR TOLES TAPÓN NEGRO DE COB. PARA CHAPAS	DECKEL, SCHWARZ, FÜR BLECHE TAMPA PRETA DE COB. PARA CHAPAS	1		X		
6	EAW0265G40A	GROUNDING CONDUCTOR CAVO DI TERRA ПРОВОД ЗАЗЕМЛЕНИЯ	CABLE TERRE CABLE TIERRA	ERDUNGSKABEL CABO DE TERRA	1		X		
7	2-23201	FLAT PLUG GROUNDING 4-POL. CONNETTORE PIATTO M/TERRA КОНТАКТ ЗАЗЕМЛЕНИЯ	CONNECTEUR PLAT TERRE CONECTOR PLATO M/TIERRA	FLACHSTECK.MASSEANSCHL.4-P CONECTOR PRATO M/TERRA	1	M12X35 8.8 A2J	X		
8	EAM0062G50A	VIBRATORY SYST. COV BOTOM COPER. INF.GRUPPO MIS. НИЖНИЙ КОЖУХ ИЗМЕРИТЕЛЬНОЙ СИСТЕМ	HABIL. INF.GROUPE MES. RAL9005 COBERTURA INF. GRUPO MIS. RAL9005	UNTERER DECKEL D. MESSEINHEIT COBER. INF.CONJUNTO MED.	1	SONAR VERSION	X		
8	EAC0100G60A	VIBRATORY SYST. COV BOTOM COPER. INF.GRUPPO MIS. НИЖНИЙ КОЖУХ ИЗМЕРИТЕЛЬНОЙ СИСТЕМ	HABIL. INFER. GROUPE MES. COBERT. INF. GRUPO MIS.	UNTERER DECKEL D. MESSEINHEIT COBERT. INF.CONJUNTO MED.	1			X	
9	1-22623A	SCREW, PHIL PAN H.TAPP. VITE AUTOF. ВИНТ С ГОЛОВКОЙ PHILIPS	VIS AUTOTAR. TORNILLO AUTORR.	SCHRAUBE, SELBSTSCHNEIDEND PARAFUSO AUTO-ROSC.	7	D3,9X13 TCB ZB 7981 C	X		
10	7-01802A	Insulating transformer 100/230V Trasformatore d'isolamento 100/230V РАЗВЯЗЫВАЮЩИЙ ТРАНСФОРМ.100/230В	TRANSFORMATEUR 100/230V Transformador 100/230V	Transformator 100/230V Transformador 100/230V	1	JP 100/230 500VA 50-60Hz	X		X
10	EAA0363G31A	Insulating transformer Trasformatore d'isolamento РАЗВЯЗЫВАЮЩИЙ ТРАНСФОРМ.	TRANSFORMATEUR Transformador	Transformator Transformador	1	230/230V E-BOX Conn.	X		X
10	EAA0373G90A	Insulating transformer 230/230V Trasformatore d'isolamento 230/230V РАЗВЯЗЫВАЮЩИЙ ТРАНСФОРМ.230/230В	TRANSFORMATEUR 230/230V Transformador 230/230V	Transformator 230/230V Transformador 230/230V	1	300VA 50Hz	X		X
10	EAA0373G92A	Insulating transformer 100/230V Trasformatore d'isolamento 100/230V РАЗВЯЗЫВАЮЩИЙ ТРАНСФОРМ.100/230В	TRANSFORMATEUR 100/230V Transformador 100/230V	Transformator 100/230V Transformador 100/230V	1	500VA 50-60Hz	X		X
11	1-10476A	BLACK CAP FOR SCREWS M5 TAPPO A CALOTTA NERO VITI M5 ЗАГЛУШКА ЧЕРНАЯ ДЛЯ ВИНТОВ M5	BOUCHON NOIR POUR VIS M5 TAPÓN CASQUETE NEGRO TORNILLOS M5	LINSENKOPFDECKEL, SCHW., F. SCHR. M5 TAMPA CALOTA PRETA PARAFUSOS M5	2			X	

A available - disponible - vorhanden - beschikbaar - tillgänglig
disponibile - disponible - disponivel - Доступно

B on request - sur demande - auf Antrag - op aanvraag - på begäran
a richiesta - a petición - no pedido - По запросу

C suggested - suggeré - vorgeschlagene - aanbevolen - föreslog
consigliato - sugerido - sugerido - Предлагается

Pos	Code	Designation Designazione ОПИСАНИЕ	Désignation Designación Benämning	Bezeichnung Designação	N.	Note Nota HOTa	A	B	C
12	1-25503A	SCREW TSEI VITE TSEI ВИНТ ТСЕИ М5Х16 ОЦИНКОВАННЫЙ	VIS FHc TORNILLO TSEI	SENKSCHRAUBE MIT INNENSECHSKANT PARAFUSO TSEI	2	5X16 10.9		X	
13	1-11533	HEX NUT DADO ГАЙКА	ECROU TUERCA	MUTTER PORCA	2	8 A2J 934		X	
14	EAC0100G63A	PLASTIC COVER ASSY M2 ASSIEME COPERTURA PLASTICA M2 ПЛАСТИКОВЫЙ КОЖУХ М2 В СБОРЕ	HABILLAGE PLASTIQUE M2 GRUPO COBERTURA PLÁSTICA M2	KUNSTSTOFFABDECKEINHEIT M2 CONJUNTO COBERTURA PLÁSTICO M2	1		X		
15	1-22323A	SELF-TAPPING SCREW VITE AUTOFILETTANTE ВИНТ САМОНАРЕЗАЮЩИЙ	VIS AUTOTAR. TORNILLO AUTORR.	AUTOM SCHNEIDSCHRIB PARAFUSO AUTO-ROSCANTE	9	"D5,5X15 MM"		X	
16	1-9841	WASHER,PLAIN d6 ZINC. RONDELLA P. d.6 ZINC. ШАЙБА	RONDELLE d.6 ARANDELA P.D.6 GALVANIZ.	SCHEIBE B 6,4 -A2J ARRUELA PLANA	7	D6 UNI6592-69 DIN 433		X	
17	1-9641	WASHER RONDELLA ШАЙБА	RONDELLE ARANDELA	UNTERLEGSCHIEBE ARRUELA	7	D4X9X0,8 ISO 7089	X		

A available - disponible - vorhanden - beschikbaar - tillgänglig
disponibile - disponible - disponível - Доступно

B on request - sur demande - auf Antrag - op aanvraag - på begäran
a richiesta - a petición - no pedido - По запросу

C suggested - suggeré - vorgeschlagene - aanbevolen - föreslog
consigliato - sugerido - sugerido - Предлагается

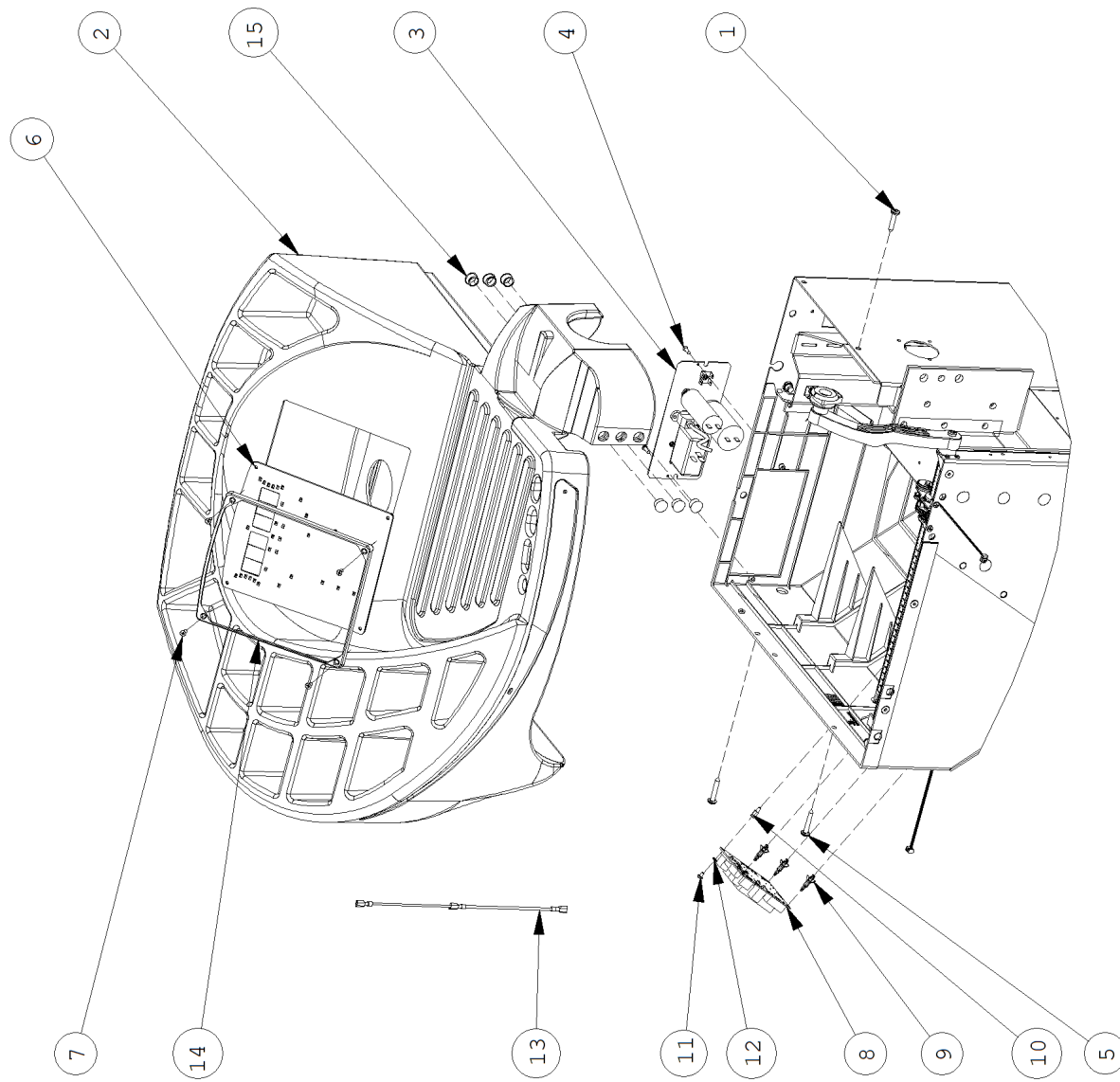

Pos	Code	Designation Designazione ОПИСАНИЕ	Désignation Designación Benämning	Bezeichnung Designação	N.	Note Nota HOTa	A	B	C
1	1-16609A	SCREW TCEI VITE TCEI ВИНТ TCEI	VIS CHc TORNILLO TCEI	ZYLINDERSCHRAUBE MIT INNENSECHSKANT PARAFUSO TCEI	2	M6X30 8.8 BR UNI 5931-67	X		
2	EAK0329G21A	WEIGHT TRAY KIT KIT PIANO PORTAPESI КОМПЛЕКТ СТОЛ ДЛЯ ВЕСОВ	KIT PLAN PORTE-POIDS KIT MESA PORTAPESAS	GEWICHTETELLER SATZ KIT PLANO PORTA-PESOS	1			X	
3	EAA0458G36A	ASSY POWER INLET GRUPPO INGRESSO ALIMENTAZIONE ВВОД ВВОДА ПИТАНИЯ	GROUPE ENTRÉE ALIMENTATION GRUPO ENTRADA ALIMENTACIÓN	EINHEIT EINGANG VERSORGUNG GRUPO ENTRADA ALIMENTAÇÃO	1		X		
3	EAA0481G95A	ASSY POWER INLET GRUPPO INGRESSO ALIMENTAZIONE Блок подачи питания	GROUPE ENTR. ALIMENTATION GRUPO ENTRADA ALIMENT.	EINHEIT EINGANG VERSORGUNG GRUPO ENTRADA ALIMENT.	1	Laser Pointer	X		
4	1-09326A	SCREW FOR PLASTIC VITE AUTOFIL. PEE PLASTICA Винт для пластика	VIS AUTOTARAUD. POUR PLASTIQUE TORNILLO AUT. PARA PLAST.	SPEZ.SCHRAUBE F/KUNSTSTOFF PARAFUSO AUTO-ROSC. PARA PLASTICO	2	D4X12	X		
5	1-16609A	SCREW TCEI VITE TCEI ВИНТ TCEI	VIS CHc TORNILLO TCEI	ZYLINDERSCHRAUBE MIT INNENSECHSKANT PARAFUSO TCEI	2	M6X30 8.8 BR UNI 5931-67	X		
6	EAA0392G37A	INTERFACE BOARD GRUPPO INTERFACCIA JBEG ИНТЕРФЕЙСНАЯ ПЛАТА	GROUPE INTERFACE JBEG GRUPO INTERFAZ JBEG	SCHNITTSTELLENEINHEIT JBEG UNIDADE INTERFACE JBEG	1		X		X
6	EAA0426G27A	INTERFACE BOARD GRUPPO INTERFACCIA JBEG ИНТЕРФЕЙСНАЯ ПЛАТА	GROUPE INTERFACE JBEG GRUPO INTERFAZ JBEG	SCHNITTSTELLENEINHEIT JBEG UNIDADE INTERFACE JBEG	1	B300	X		X
7	1-24123A	SCREW, SELFTHREAD. VITE AUTOF. ВИНТ САМОНАРЕЗНОЙ (САМОРЕЗ)	VIS, AUTOFIL. TORNILLO AUTOFILETANTE	SCHRAUBE PARAFUSO AUTO-ROSQ.	4	D4,2x13 TSP	X		
8	EAP0276G50A	A-Weight Laser Board Scheda A-Weight Laser Плата лазера A-Weight	Carte A-Weight Laser Tarjeta A-Weight Laser	A-Weight Laser Encoder Placa A-Weight Laser	1		X		X
9	2-07932A	Locking board support Supporto autobloc. X schede Держатель платы лазера	Support aut. board Soporte aut. board	Halter selbst. board Suporte autbl. Para placas	3	LCBS-2-6-01		X	
10	1-11961A	Threaded Spacer Distanziale filettato УДЛИНИТЕЛЬ С РЕЗЬБОЙ M4X10	Entretoise Distanciador	Abstandstück Distanciador rosqueado	1	,M4X10 M/F		X	
11	1-19804	Screw, Phil Pan head M4X6 Vite TCB Винт M4x6 с головкой Philips	VIS CB Tornillo	Schraube Parafuso TCB	1	M4 x 6 UNI 7687		X	
12	1-5547	WASHER RONDELLA ШАЙБА	RONDELLE ARANDELA	UNTERLEGSCHIEBE ARRUELA	1	Ø 4,2		X	
13	EAW0276G39A	CABLE ASM, AWP ENCODER CAVO ENCODER AWP КАБЕЛЬ ЭНКОДЕРА AWP В СБОРЕ	CABLE ENCODEUR AWP CABLE ENCOGER AWP	ENCODERKABEL AWP CABO ENCODER AWP	1		X		X
14	EAC0113G71A	Display cover Copertchio display КОЖУХ ДИСПЛЕЯ	COUVERCLE DISPLAY TAPA DISPLAY	ABDECKUNG DISPLAY TAMPA DISPLAY	1		X		
15	EAC0060G00A	VIBRATORY SYSTEM HOLES CUP TAPPO FORI GRUPPO MISURA ПРОБКА ДЛЯ ОТВЕРСТИЙ	BOUCHON, GROUPE MESURE TAPON-GRUPO MEDIDAS	ABDECKKAPPE 15,9 MM TAMPA FUROS	6		X		

A available - disponible - vorhanden - beschikbaar - tillgänglig
disponibile - disponible - disponivel - Доступно

B on request - sur demande - auf Antrag - op aanvraag - på begäran
a richiesta - a petición - no pedido - По запросу

C suggested - suggeré - vorgeschlagene - aanbevolen - föreslog
consigliato - sugerido - sugerido - Предлагается

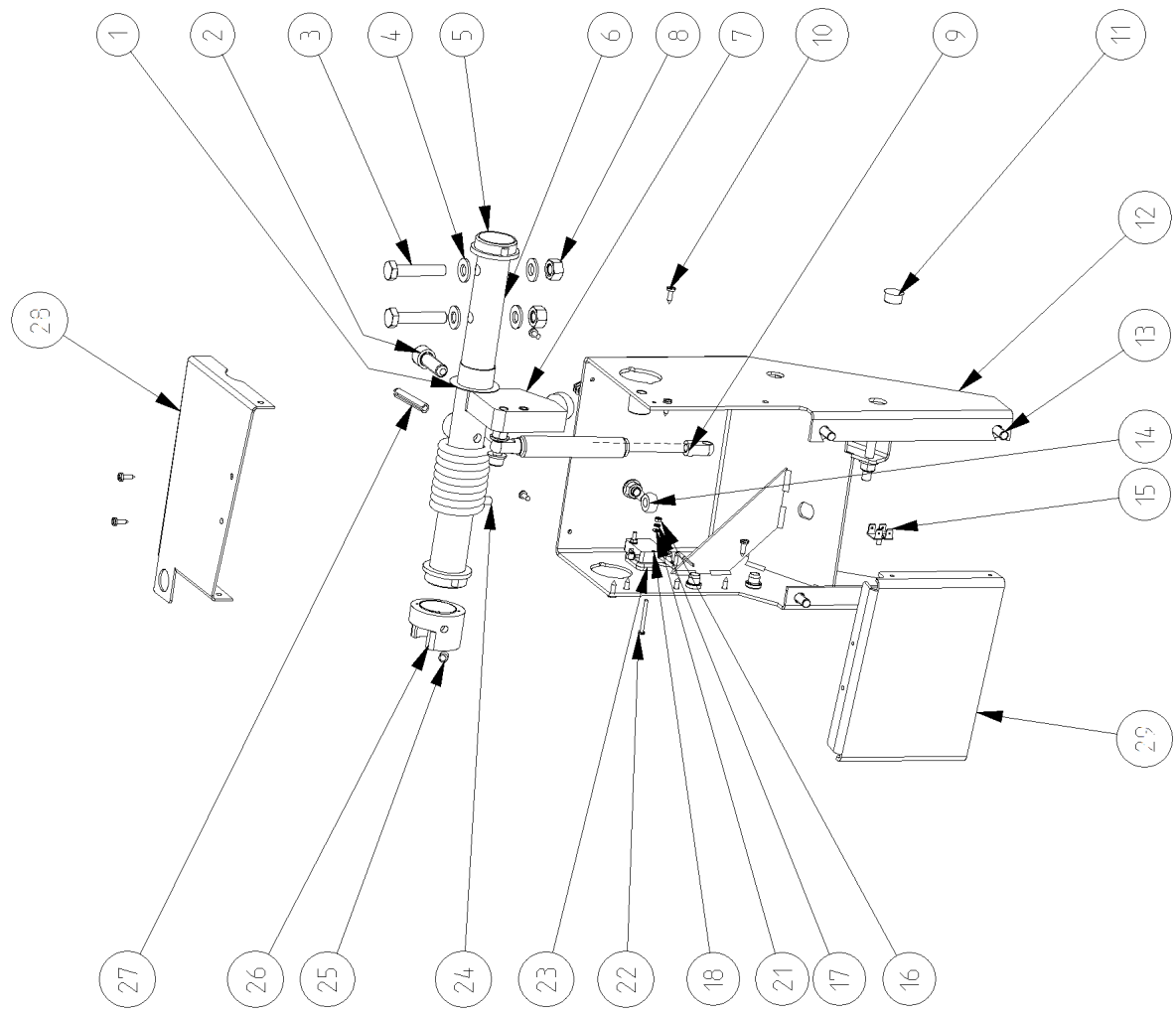

Pos	Code	Designation Designazione ОПИСАНИЕ	Désignation Designación Benämning	Bezeichnung Designação	N.	Note Nota HOTa	A	B	C
1	1-22441A	SHIM RING RONDELLA DI RASAMENTO КОЛЬЦО	RONDELLE D'ARASEMENT ARANDELA DE ENRASE	PASSSCHEIBE ARRUELA DE RASPAGEM	1	32X45X1 DIN988	X		
2	1-20409	SCREW, HEX SOCKET HEAD CAP VITE TCEI ВИНТ С ВНУТРЕННИМ ШЕСТИГРАННИКОМ	VIS CHc TORNILLO TCEI	ZYLINDERSCHR. M/INNENSECHSK PARAFUSO TCEI	1	M12X35 8.8 A2J 912 D.32	X		
3	1-19901	SCREW, HEX HEAD MACHINE VITE TE ВИНТ С ШЕСТИГРАННОЙ ГОЛОВКОЙ	VIS H TORNILLO TE	SECHSKANTSCHRAUBE PARAFUSO TE	2		X		
4	1-10141A1	WASHER P.d.10 RONDELLA P.d.10 ZINC.BIANCA ШАЙБА D 10	RONDELLE D 10 ARANDELA D 10	SCHEIBE D.10 ARRUELA P.d.10 ZINC.BRANCA	4		X		
5	EAC0058D36A	WHEELGUARD BUSHING BOCCOLA GUIDA PROTEZIONE RUOTA ВТУЛКА ЗАЩИТНОГО КОЖУХА	DOUILLE GUIDE PROTECTION ROUE CASQUILLO GUÍA PROTECCIÓN RUEDA	FÜHRUNGSBUCHSE F. RADSCHUTZ ARRUELA GUIA PROTEÇÃO RODA	2	D.32	X		
6	EAM0076G37A	W.G. SHAFT ALBERO PROTEZIONE RUOTA ВАЛ ЗАЩИТНОГО КОЖУХА	ARBRE PROTECTION ROUE ÁRBOL PROTECCIÓN RUEDA	RADSCHUTZWELLE EIXO PROTEÇÃO RODA	1		X		
7	EAM0076G38A	WHEELGUARD STOP FERMO PROTEZIONE RUOTA ZINC. ОГРАНИЧИТЕЛЬ ХОДА КОЖУХА	ARRET PROTECTION ROUE ZING. TOPE PROTECCIÓN RUEDA CINC.	STOPPER F. RADSCHUTZ, VERZINKT FIXADOR PROTEÇÃO RODA ZINC.	1		X		
8	1-18733A	NUT, SELF LOCK. ALL-METAL DADO M10 AUT.INS.MET. ГАЙКА САМОКОНТРЯЩАЯСЯ	ECROU M10 AUT.FR. MET. TUERCA M10 AUT.INS.MET.	MUTTER SELBSTHEMMEND METAL. PORCA M10 AUT.INS.MET.	2	M10 A2J 6925	X		
9	1-06769A	GAS SPRING АММОРТИЗАТОРЕ ГАЗОНАПОЛНЕННЫЙ АМОТИЗАТОР	AMORTISSEUR AMORTIGUADOR	RADSCHUTZDÄMPFER-EINHEIT MOLA DE GÁS	1		X	X	
10	1-22623A	SCREW, PHIL PAN H.TAPP. VITE AUTOF. ВИНТ С ГОЛОВКОЙ PHILIPS	VIS AUTOTAR. TORNILLO AUTORR.	SCHRAUBE, SELBSTSCHNEIDEND PARAFUSO AUTO-ROSC.	11	D3,9X13 TCB ZB 7981 C	X		
11	EAC0060G00A	VIBRATORY SYSTEM HOLES CUP TAPPO FORI GRUPPO MISURA ПРОБКА ДЛЯ ОТВЕРСТИЙ	BOUCHON, GROUPE MESURE TAPON-GRUPO MEDIDAS	ABDECKKAPPE 15,9 MM TAMPA FUROS	1		X		
12	EAS2133G38A	WHEELGUARD AND MONITOR SUP. SUPPORTO MONITOR E PROT. R. КРОНШТЕЙН КОЖУХА И МОНИТОРА	SUPPORT ECRAN ET PROT. R. SOPORTE MONITOR Y PROT. R.	TRÄGER F. RADSCHUTZ U. MONITOR SUPORTE MONITOR E PROT. R.	1		X		
13	1-17709	SCREW TCEI 8X20 8G VITE TCEI ВИНТ TCEI M8X20	VIS CHc TORNILLO TCEI	ZYLINDERSCHR.B.M.ISKT.M8X20-8.8-A2J PARAFUSO TCEI	4	M8X100 8K ISO 4762	X		
14	1-01530	EYE-SCREW M8x50 VITE CON OCCHIELLO ВИНТ M8X50	VIS A CEILLET TORNILLO CON RANURA	ÖSENSCHRAUBE PARAFUSO COM OLHAL	1		X		
15	2-23201	FLAT PLUG GROUNDING 4-POL. CONNETTORE PIATTO M/TERRA КОНТАКТ ЗАЗЕМЛЕНИЯ	CONNECTEUR PLAT TERRE CONECTOR PLATO M/TIERRA	FLACHSTECK.MASSEANSCHL.4-P CONECTOR PRATO M/TERRA	1	M12X35 8.8 A2J	X		
16	1-11233	NUT - M3 WHITE ZINCKED DADO M3 CL.8 ГАЙКА M3 ОЦИНКОВАННАЯ	ECROU M3 6S TUERCA M3 CL.8 ZINC.	SECHSKANTMUTTER PORCA M3 CL.8 ZINC.	2	M3 CL.8 ZINC. UNI5588-65	X		
17	1-1248	WASHER, TOOTHED EXTERNAL RONDELLA DENTELLATA EST. ШАЙБА С ВНЕШНЕЙ НАКАТКОЙ	RONDELLE ARANDELA DENTADA EXT.	SCHEIBE MIT AUSSENZAHNUNG ARRUELA DENTADA EXT.	2	D.3 DIN 6798/A	X		

A available - disponible - vorhanden - beschikbaar - tillgänglig
disponibile - disponibile - disponivel - Доступно

B on request - sur demande - auf Antrag - op aanvraag - på begäran
a richiesta - a petición - no pedido - По запросу

C suggested - suggeré - vorgeschlagene - aanbevolen - föreslog
consigliato - sugerido - sugerido - Предлагается

Pos	Code	Designation Designazione ОПИСАНИЕ	Désignation Designación Benämning	Bezeichnung Designação	N.	Note Nota HOTa	A	B	C
18	2-7261	WHEELGUARD SWITCH INTERRUPTORE PROTEZIONE RUOTA МИКРОВЫКЛЮЧАТЕЛЬ КОЖУХА	INTERRUPTEUR PROTECTION ROUE INTERRUPTOR PROTECCIÓN RUEDA	SCHALTER F. RADSCHUTZ INTERRUPTOR PROTEÇÃO RODA	1		X		X
21	1-9541	WASHER PLAIN D3 RONDELLA PIANA d.3 ZINC ШАЙБА	RONDELLE d.3 ARANDELA PLANA D.3 GALVANIZ.	SCHEIBE A 3,2 -A2J ARRUELA PLANA d.3 ZINC	2	Ø 3 DIN 125A	X		
22	1-7104	SCREW, SLOTTED CHEESE HEAD VITE TC ВИНТ С ЦИЛИНДРИЧЕСКОЙ ГОЛОВКОЙ	VIS C TORNILLO TC	ZYLINDERSCHRAUBE PARAFUSO TC	2	TC M3x30 4S, ZINC UNI 6107-67	X		
23	EAC0053J16A	MICROSWITCH PLATE PIASTRINA MICROINTERRUPTORE ПЛАТА МИКРОВЫКЛЮЧАТЕЛЯ	PLAQUETTE MICRORUPTEUR PLACA MICROINTERRUPTOR	PLATTE F. MIKROSCHALTER PLAQUINHA MICROINTERRUPTOR	1		X		
24	1-04267A	WHEELGUARD SPRING MOLLA PROTEZIONE RUOTA ПРУЖИНА ЗАЩИТНОГО КОЖУХА	RESSORT PROTECTION ROUE MUELLE PROTECCIÓN RUEDA	RADSCHUTZFEDER MOLA PROTEÇÃO RODA	1		X		
25	1-49010A	SCREW, SOCKET WITH CUP POINT VITE STEI P.COPPA ВИНТ ПОТАЙНОЙ	VIS FHc ENJOLIVEUR TORNILLO STEI P. CAJA	MADENSCHR.M/INNENSECHSK.WANNE PARAFUSO STEI P.COPPA	1		X		
26	EAC0058D38A	MICRO FIXING RING ANELLO FISSAGGIO MICRO КРЕПЕЖНОЕ КОЛЬЦО МИКРОВЫКЛЮЧАТЕЛЯ	BAGUE FIXATION MICRO ANILLO FIJACIÓN MICRO	BEFESTIGUNGSRING F. MIKROSCH. ANEL FIXAÇÃO MICRO	1		X		
27	1-12452	PINS - STRAIGHT SLOTTED SPINA ELASTICA ПАЛЕЦ С ПАЗОМ	BROCHE ELASTIQUE PASADOR ELÁSTICA	STIFT, ELASTISCH TOMADA ELASTICA	1	8X45 1481	X		
28	EAS2133G36A	COVER WHEELG. SUPP. COPER. PROT RUOTA КРОНШТЕЙН ЗАЩИТНОГО КОЖУХА	HABIL.PROT. ROUE COBER. PROT RUEDA	ABDECKUNG RAD. AUSSENBEF. COBER. PROT RODA	1		X		
29	EAS2177G41A	BACK PACK FRONT COVER COPERCHIO FRONTALE BACCPACK ПЕРЕДНИЙ КОЖУХ ВЕРХНИЙ	COVERTURE FRONTALE BACK PACK COBERTURA FRONTALBACK PACK	BACK PACK FRONT DECKUNG COBERTURA FRONTAL BACK PACK	1			X	

EAZ0136G42A.B

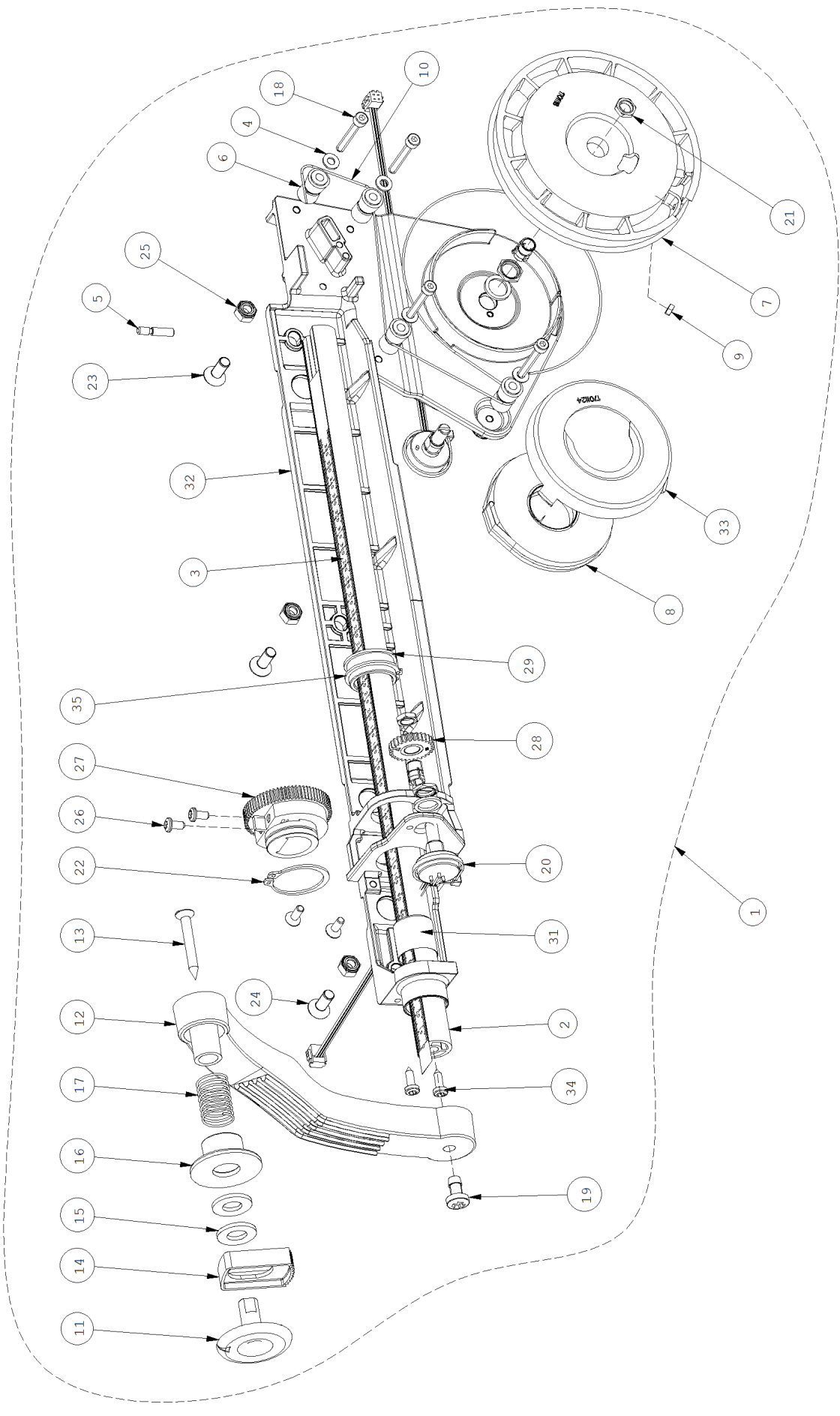

Pos	Code	Designation Designazione ОПИСАНИЕ	Désignation Designación Benämning	Bezeichnung Designação	N.	Note Nota HOTa	A	B	C
1	EAA0471G18A	M2 SAPE 1D-2D ASSY M2 SAPE 1D-2D ASSY M2 SAPE 1D-2D ASSY	M2 SAPE 1D-2D ASSY M2 SAPE 1D-2D ASSY	M2 SAPE 1D-2D ASSY M2 SAPE 1D-2D ASSY	1	ASSY GRUPPO	X		
2	EAM0053G19A	STANDARD. ROD SAPE, M2 ASTA CALIBRO M2 UNIFICATO ШТАНГА ИЗМЕРИТЕЛЯ ДИСТАНЦИИ M2	JAUGE ETALON M2 UNIFIE VARILLA CALIBRE M2 UNIFICADO	KALIBRIERSTANGE M2, STANDARD HASTE CALIBRADOR M2 UNIFICADO	1		X		
3	EAM0140G91A	DISTANCE SCALE DECAL (MM) TARGA ASTA CALIBRO IN MM x SAPE M2 НАКЛЕЙКА РЫЧАГА	PLAQUE JAUGE ETALON EN MM TARJETA VARILLA CALIBRE EN MM.	SKALA KALIBRIERSTANGE IN MM Placa haste calibrador	1	SAPE M2	X		
4	1-9641	WASHER RONDELLA ШАЙБА	RONDELLE ARANDELA	UNTERLEGSCHIEBE ARRUELA	4	D4X9X0,8 ISO 7089	X		
5	EAM0181G08A	MACHINED SCREW M4 VITE M4 CON GOLA ВИНТ	VIS USINÉE TORNILLO MECANIZ.	SCHRAUBE BEARB. PARAFUSO TRAB.	1	M4	X		
6	EAM0005D35A	GUIDING REEL RULLO DI RINVIO НАПРАВЛЯЮЩАЯ РЕЛЬСА	ROULEAU DE RENVOI RODILLO DE REENVÍO	UMLENKROLLE ROLO DE REENVIO	4		X		
7	EAC0058D06A	Return pulley Puleggia rinvio Шкив	Poulie renvoi Polea de reenvío	Umlenkscheibe Polia reenvio	1		X		
8	1-08167A	STAND. SAPE TENSION SPRING MOLLA RITORNO ASTA SAPE UNIF. ПРУЖИНА НАТЯЖЕНИЯ ИЗМЕРИТЕЛЯ	RESSORT RETOUR JAUGE SAPE UNIF. MUELLE RETORNO VARILLA SAPE UNIF.	RÜCKHOLFEDER F/STANGE, SAPE STD MOLA DE RETORNO HASTE SAPE UNIF.	1			X	
9	1-11233	NUT - M3 WHITE ZINCKED DADO M3 CL.8 ГАЙКА M3 ОЦИНКОВАННАЯ	ECROU M3 6S TUERCA M3 CL.8 ZINC.	SECHSKANTMUTTER PORCA M3 CL.8 ZINC.	1	M3 CL.8 ZINC. UNI5588-65	X		
10	6-00604A	ROPE SPECTRA 1000 D 0,6 CORDA SPECTRA 1000 D 0,6 ШНУР SPECTRA 1000 D 0,6	CORDE SPECTRA 1000 D 0,6 CUERDA SPECTRA 1000 D 0,6	SEIL SPECTRA 1000 D 0,6 CORDA SPECTRA 1000 D 0,6	0,9	"0,52M"	X		
11	EAC0058D11A	Feeler disk Disco tastatore ДИСК ДЕРЖАТЕЛЯ	Disque de contact Disco palpador	Tastscheibe Disco apalpador	1		X		X
12	EAC0054P01A	ARM, AXCEL CALIPER BRACCIO ASTA CALIBRO ДЕРЖАТЕЛЬ	JAUGE ETALON BRAZO VARILLA CALIBRE	ARM D. KALIBRIERSTANGE BRAÇO HASTE CALIBRADOR	1		X		
13	1-3624	SCREW POLYPLAST VITE AUTOF.X PLAST.TS ВИНТ ПЛАСТИКОВЫЙ	VIS AUTOTAR. POUR PLAST. TORNILLO AUTOENROSC. PARA PLAST.	SCHR.SELBSTSCHN.KUNSTSTOFF PARAFUSO AUTO-ROSQX PLAST.	1	M5x40	X		
14	EAC0058D09A	REGISTER, EJECTION GUIDA D'ESPULSIONE ПОДВИЖНАЯ ВСТАВКА	GUIDE D'EXPULSION GUÍA DE EXPULSIÓN	AUSWURFFÜHRUNG GUIA DE EXPULSÃO	1		X		
15	1-10141A1	WASHER P.d.10 RONDELLA P.d.10 ZINC.BIANCA ШАЙБА D 10	RONDELLE D 10 ARANDELA D 10	SCHEIBE D.10 ARRUELA P.d.10 ZINC.BRANCA	2		X		
16	EAC0058D10A	RING, PUSH ANELLO DI SPINTA НАЖИМНОЕ КОЛЬЦО	BAGUE DE POUSSEE ANILLO DE EMPUJE	DRUCKRING ANEL DE IMPULSÃO	1		X		
17	1-06868A	SPRING, COMPRESSION MOLLA DI COMPRESIONE ПРУЖИНА	RESSORT DE COMPRESSION MUELLE DE COMPRESIÓN	DRUCKFEDER MOLA DE COMPRESSÃO	1	2098(B)	X		

A available - disponible - vorhanden - beschikbaar - tillgänglig
disponibile - disponible - disponivel - Доступно

B on request - sur demande - auf Antrag - op aanvraag - på begäran
a richiesta - a petición - no pedido - По запросу

C suggested - suggeré - vorgeschlagene - aanbevolen - föreslog
consigliato - sugerido - sugerido - Предлагается

Pos	Code	Designation Designazione ОПИСАНИЕ	Désignation Designación Benämning	Bezeichnung Designação	N.	Note Nota HOTa	A	B	C
18	1-13909	SCR - HEX SKT HD CAP VITE TCEI ZINC. ВИНТ С ШЕСТИГРАННОЙ ГОЛОВКОЙ	VIS CHc ZING. TORNILLO TCEI	ZYLINDERSCHR. MIT INNENSECHSK. PARAFUSO TCEI	4	M4x30 912	X		
19	1-3824	SCREW VITE AUTOM.TC CROCE ВИНТ	VIS AUT. TC CRUCIF. TORNILLO AUTOM.TC CRUZ	ZYLINDERSCHRAUBE, SELBSTSCHN PARAFUSO AUTOM.TC CRUZ	1	M6x12 DIN 7516AE	X		
20	EAA0266D20A	Potentiometer unit with nut Gruppo potenziometro con dado Потенциометр с гайкой	Groupe potentiomètre avec écrou Grupo del potenciómetro con tuerca	Potentiometer mit Mutter Grupo potenciômetro com porca	2		X		
21	2-07657A	CLAMPING DEVICE BOCCOLA A PINZA ЗАЖИМНАЯ ГАЙКА	DOUILLE A PINCE CASQUILLO DE PINZA	STOCKZWINGE ARRUELA A PINÇA	2		X		
22	1-13377A	CIRCLIP FOR SHAFT ANELLO SEEGER СТОПОРНОЕ КОЛЬЦО	CIRCLIP ANILLO SEEGER	SEEGER-RING ANEL SEEGER	1	D.27 UNI 7435	X		
23	1-22003A	SCREW 6X16 10K VITE TSEI ВИНТ 6X16	VIS FHc TORNILLO TSEI	SCHRAUBE 6X16 10K PARAFUSO TSEI	3	M6X16 DIN 7991	X		
24	1-17726A	SCREW TPS VITE AUTOF. ВИНТ С ГОЛОВКОЙ	VIS AUTOF. TORNILLO AUTOF.	BLECHSCHRAUBE PARAFUSO AUTOF.	2	9X13 DIN7982-F 3,	X		
25	1-9933	NUT, PREVAILING TORQUE M6 DADO M6 AUT. BAS.CL.6 ANE.PLA.BI Гайка	ECROU M6 AUTO-BL. TUERCA M6 AUT. BAS.CL.6	MUTTER, SELBSTSICHERND M6 PORCA M6 AUT. BAIX.CL.6 ANE.PLA.BI	3	M6 DIN 985	X		
26	1-11726A	SCREW FOR PLAST. PHIL. PAN VITE PER PLASTICA AUTOFIL ВИНТ ДЛЯ ПЛАСТИКА	VIS POUR PLASTIQUE AUTOTAR. TORNILLO PARA PLÁSTICO AUTOENROSC.	SCHRAUBE SELBSTSCHN. F/KUNSTSTOFF PARAFUSO PARA PLÁSTICO AUTO-ROSCQ	2	M=4,0 x 8 PLASTIC	X		
27	EAC0058D12A	COG WHEEL 56 TEETH INGRANAGGIO 56 DENTI ЗУБЧАТОЕ КОЛЕСО 56 ЗУБЬЕВ	ENGRENAGE 56 DENTS ENGRANAJE 56 DIENTES	ZAHNRAD, 56 ZÄHNE ENGRENAGEM 56 DENTES	1		X		
28	EAC0058D13A	Wheel gear Ingranaggio ruota Шестерня колеса	Engrenage roue Rueda del engranaje	Zahnrad Engrenagem Roda	1		X		
29	EAM0068G76A	S2-D2 BUSHING BOCCOLA S2-D2 ВТУЛКА S2-D2	BRIDE CASQUILLO	BUCHSE ARRUELA S2-D2	1		X		
31	1-13865A	BUSHING BOCCOLA ВТУЛКА	DOUILLE CASQUILLO	BUCHSE ARRUELA	1	IGUS GSM202120	X		
32	EAM0125G67A	MACHINED SAPE SUPPORT for M Cabinet SUPPORTO SAPE S2 MODIFICATO ДЕРЖАТЕЛЬ S2 SAPE	SUPPORT SAPE S2 SOPORTE SAPE S2	SAPE M2 SUPORTE SAPE S2 TRABALHADO	1		X		
33	EAC0058D58A	Safety cover Coperchio di sicurezza Защитная крышка	Couvercle de sécurité Tapa de seguridad	Sicherheitsdeckel Tampa de segurança	1		X		
34	1-22623A	SCREW, PHIL PAN H.TAPP. VITE AUTOF. ВИНТ С ГОЛОВКОЙ PHILIPS	VIS AUTOTAR. TORNILLO AUTORR.	SCHRAUBE, SELBSTSCHNEIDEND PARAFUSO AUTO-ROSC.	2	D3,9X13 TCB ZB 7981 C	X		
35	1-4577	RING SNAP ANELLO ARRESTO СТОПОРНОЕ КОЛЬЦО	ANNEAU ANILLO TOPE	RING ANEL PARADA	1	"D25X1,2"	X		

A available - disponible - vorhanden - beschikbaar - tillgänglig
disponibile - disponible - disponivel - Доступно

B on request - sur demande - auf Antrag - op aanvraag - på begäran
a richiesta - a petición - no pedido - По запросу

C suggested - suggeré - vorgeschlagene - aanbevolen - föreslog
consigliato - sugerido - sugerido - Предлагается

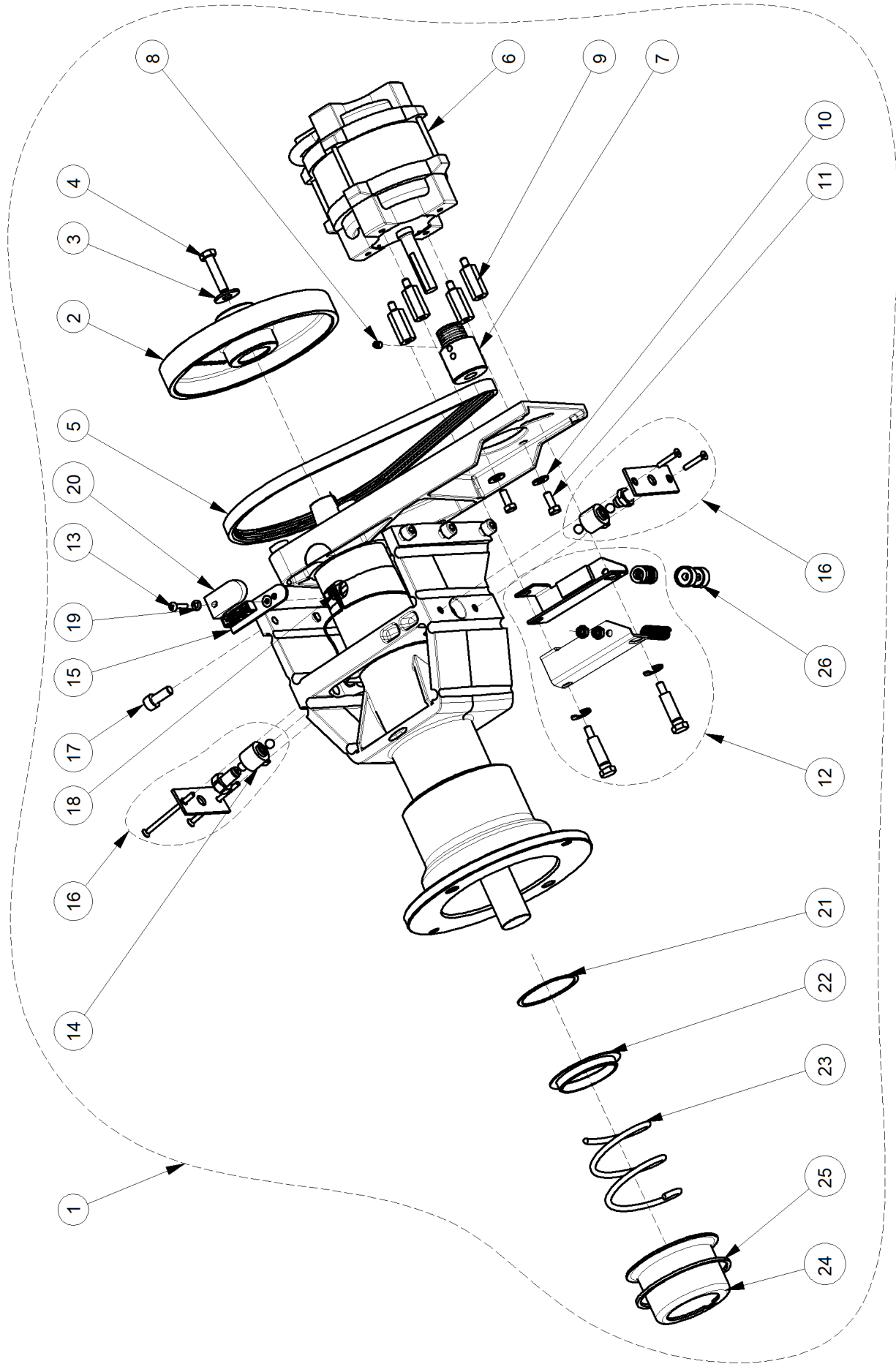

Pos	Code	Designation Designazione ОПИСАНИЕ	Désignation Designación Benämning	Bezeichnung Designação	N.	Note Nota HOTa	A	B	C
1	EAA0338G53A	ALU VS MOT. INT. FL.D. 40/28,5 POL. RING ALU GRUPPO MISURA FL. INTEGRATA АЛЮ. ВИБРАТОР ИНТЕГР. ФЛАНЕЦ 40/28,5 Г	ENSEMBLE VIBRATOIRE GRUPO DE MEDIDA	SCHWINGER, KOMPLETT CONJUNTO SISTEMA DE MEDIDA	1		X		
1	EAA0364G85A	ALU VS MOT. INT. FL.D. 40/28,5 POL. UL ALU GRUPPO DI MISURA FL. INT. UL АЛЮ. ВИБРАТОР ИНТЕГР. ФЛАНЕЦ 40/28,5 У	ENSEMBLE VIBRATOIRE UL GRUPO DE MEDIDA UL	SCHWINGER, KOMPLETT UL CONJUNTO SISTEMA DE MEDIDA UL	1		X		
2	EAM0005D12A	DRIVE PULLEY PULEGGIA DI TRASMISSIONE ШКИВ	POULIE D'ENTRAÎNEMENT POLEA DE TRANSMISSION	ANTRIEBSSCHEIBE POLIA DE TRANSMISSÃO	1		X		
3	1-17841	WASHER - d. 8X24 RONDELLA COMUNE d.8x24 ZINC. ШАЙБА 8X24	RONDELLE d.8X24 ARANDELA COMUN D.8X24 GALVANIZ.	SCHEIBE B 8,4 -A2J ARRUELA COMUM d.8x24 ZINC.	1	d. 8X24 UNI6593	X		
4	1-32901	HEXAGON HEAD SCREW VITE TE ВИНТ С ШЕСТИГРАННОЙ ГОЛОВКОЙ	VIS H TORNILLO TE	SECHSKANTSCHRAUBE PARAFUSO TE	1	M8X35 933	X		
5	8-3531	BELT CINGHIA РЕМЕНЬ	COURROIE CORREA	RIEMEN CORREIA	1	5PJ711 7867	X	X	
6	2-59266A	MOTOR INCL. CONNECTOR Y2K MOTORE CON CONNETTORE Y2K ДВИГАТЕЛЬ С РАЗЪЕМОМ Y2K	MOTEUR MOTOR CON CONECTOR Y2K	MOTOR MIT Y2K-VERBINDER MOTOR COM CONECTOR Y2K	1		X		
6	2-59366A	UL MOTOR INCL. CONNECTOR Y2K UL MOTORE CON CONNETTORE Y2K UL ДВИГАТЕЛЬ С РАЗЪЕМОМ Y2K	UL MOTEUR UL MOTOR CON CONECTOR Y2K	UL MOTOR MIT Y2K-VERBINDER UL MOVIM.R COM CONECTOR Y2K	1	US ONLY WS 120W	X		
7	EAM0005D08A	MOTOR PULLEY PULEGGIA MOTORE ШКИВ ЭЛЕКТРОДВИГАТЕЛЯ	POULIE MOTEUR POLEA MOTOR	MOTORSCHIEBE POLIA MOVIM.R	1		X		
8	1-28410	SCREW VITE ВИНТ	VIS TORNILLO	SCHRAUBE PARAFUSO	1	M6X8 915	X		
9	EAM0005D09A	SPACER FOR MOTOR Distanziale per motore ПРОСТАВКА КРЕПЛЕНИЯ ЭЛЕКТРОДВИГАТЕЛЯ	PIÈCE D'ÉCARTEMENT DU MOTEUR DISTANCIADOR PARA MOTOR	MOTOR-DISTANZSTÜCK DISTANCIADOR PARA MOVIM.R	4		X		
10	1-16641	Washer plain Rondella piana ШАЙБА	Rondelle plate Arandela plana	Unterlegscheibe, flach ARRUELA plana	2	D. 6,4 9021	X		
11	1-46701A	HEX HEAD SCREW VITE TE ВИНТ	VIS H TORNILLO TE	SECHSKANTSCHRAUBE PARAFUSO TE	2	M6X16 933	X		
12	EAA0332G12A	MAIN SHAFT LOCK ASSEMBLY FRENO DI ARRESTO COMPL. СТОПОР ВАЛА В СБОРЕ	ENS. DE BLOCAGE ARBRE PRINCIPAL FRENO DE PARO COMPLEM	FESTSTELLBREMSE, KOMPLETT FREIO DE PARADA COMPL.	1		X		
13	1-35006A	SCREW VITE ВИНТ	VIS TORNILLO	SCHRAUBE PARAFUSO	1	M4X20 7985	X		
14	EAA0260D59A	TRANSDUCER TRASDUTTORE ПРЕОБРАЗОВАТЕЛЬ	CAPTEUR TRANSDUCTOR	MESSGEBER TRANSDUTOR	2		X	X	
15	EAA0344G00A	OPTO-ELECTRONIC UNIT SCHEDE OPTO-ENCODER CONLENTE БЛОК ОПТО-ЭНКОДЕРА С ЛИНЗОЙ	CARTE OPTO-ENCODER AVEC LENTILLE TARJETA OPTO-ENCODER CONLENTE	OPTOELEKTRONIKKARTE MIT LINSE CONJUNTO OPTO-ENCODER COMLENTE	1		X	X	

A available - disponible - vorhanden - beschikbaar - tillgänglig
disponibile - disponible - disponivel - Доступно

B on request - sur demande - auf Antrag - op aanvraag - på begäran
a richiesta - a petición - no pedido - По запросу

C suggested - suggeré - vorgeschlagene - aanbevolen - föreslog
consigliato - sugerido - sugerido - Предлагается

Pos	Code	Designation Designazione ОПИСАНИЕ	Désignation Designación Benämning	Bezeichnung Designação	N.	Note Nota HOTa	A	B	C
16	EAA0328G16A	TRANSDUCER FIXING UNIT GRUPPO FISSAGGIO PIEZO ФИКСАТОР ПРЕОБРАЗОВАТЕЛЯ	MOYENS DE FIXATION DU CAPTEUR GRUPO FIJACIÓN PIEZA	MESSGEBER-BEFESTIGUNGSEINHEIT CONJUNTO FIXAÇÃO PEÇA	1		X		X
17	1-17709	SCREW TCEI 8X20 8G VITE TCEI ВИНТ TCEI M8X20	VIS CHc TORNILLO TCEI	ZYLINDERSCHRUB.M.ISKT.M8X20-8.8-A2J PARAFUSO TCEI	6	M8X100 8K ISO 4762	X		
18	EAW0240G67A	CABLE WITHOUT TEMP. SENSOR CAVO SENZA SENSORE TEMPERATURA КАБЕЛЬ БЕЗ ТЕМПЕРАТУРНОГО ДАТЧИКА	CÂBLE SANS CAPTEUR DE TEMPER. CABLE SIN SENSOR TEMPERATURA	KABEL OHNE TEMPERATURFÜHLER CABO SEM SENSOR DE TEMP.	1		X		X
19	1-9641	WASHER RONDELLA ШАЙБА	RONDELLE ARANDELA	UNTERLEGSCHIEBE ARRUELA	1	D4X9X0,8 ISO 7089	X		
20	EAC0094G11A	ENCODER BOARD PROTECTION PROTEZIONE SCHEDE ENCODER ЗАЩИТА ПЛАТЫ ЭНКОДЕРА	PROTECTION CARTE ENCODER PROTECCIÓN TARJETA ENCODER	SCHUTZ ENCODERPLATINE PROTEÇÃO PLACA ENCODER	1		X		
21	1-17641	WASHER 53x60x1 RONDELLA DI SPESS. ШАЙБА 53x60x1	RONDELLE ARANDELA	SCHEIBE ARRUELA	1		X		
22	EAC0058D14A	Spring centring ring Anello centraggio molla ПРУЖИНА	Anneau de centrage du ressort MUELLE de centrage del anillo	Federzentriring Anel centragem mola	1		X		
23	1-07768A	Compression spring Molla a compressione Пружина сжатия	Ressort à pression MUELLE a presión	Druckfeder Mola de compressão	1	5X63X180 2098	X		
24	EAS2025D14A	Spring guide Guida molla ПРУЖИНА	Carter ressort Guía del muelle	Federtopf Guia mola	1		X		
25	1-13077	CIRCLIP ANELLO ELASTICO СТОПОРНОЕ КОЛЬЦО SB 92	ANNEAU ANILLO ELÁSTICO	RING ANEL ELASTICO	1	SB 92	X		
26	EAM0005D18A	SPACER Distanziale per cavo freno ВТУЛКА	ENTRETOISE DISTANCIADOR	DISTANZSTÜCK DISTANCIADOR PARA CABO FREIO	2		X		

A available - disponible - vorhanden - beschikbaar - tillgänglig
disponibile - disponible - disponivel - Доступно

B on request - sur demande - auf Antrag - op aanvraag - på begäran
a richiesta - a petición - no pedido - По запросу

C suggested - suggeré - vorgeschlagene - aanbevolen - föreslog
consigliato - sugerido - sugerido - Предлагается

EAZ0033G88A.C

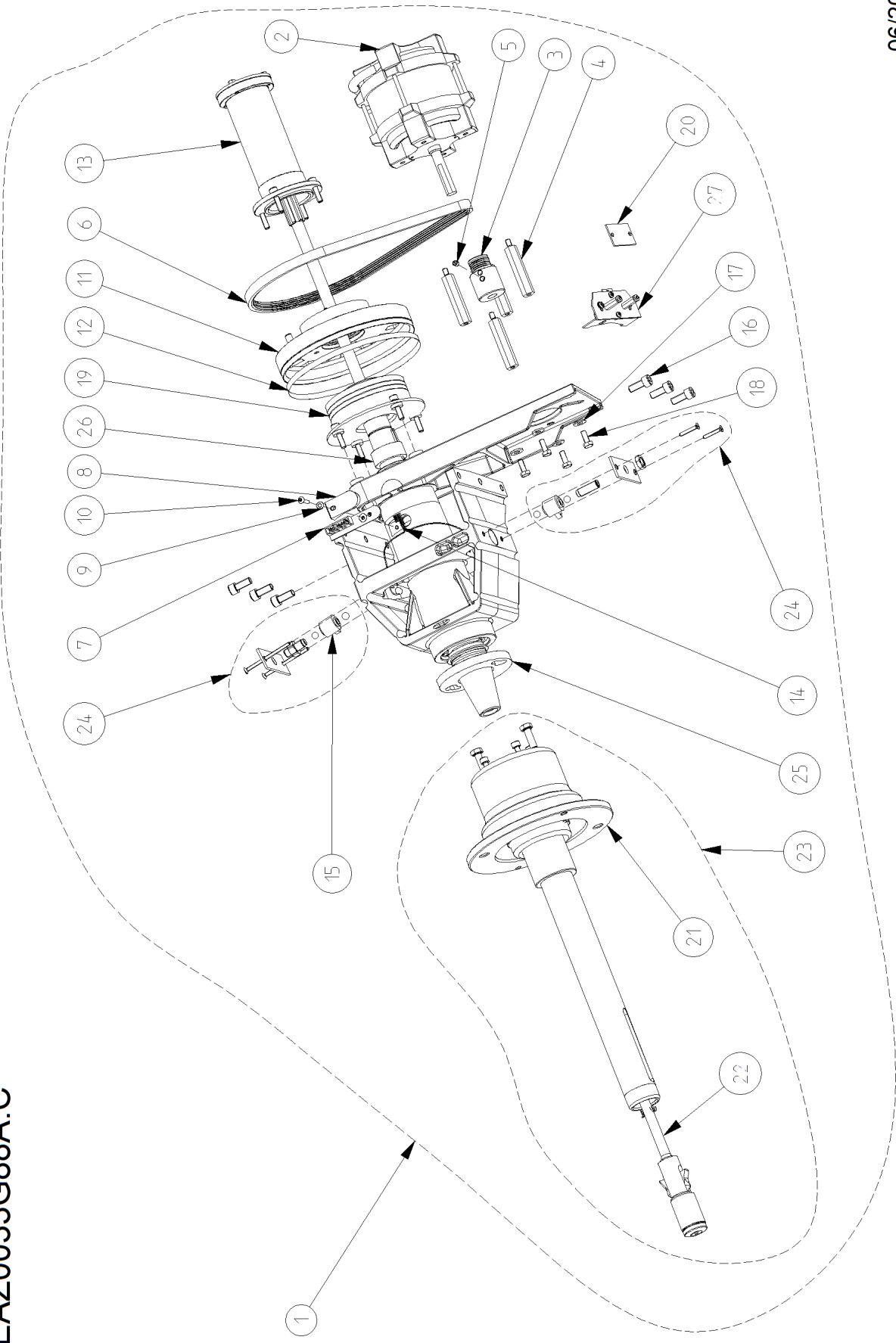

06/2016

Pos	Code	Designation Designazione ОПИСАНИЕ	Désignation Designación Benämning	Bezeichnung Designação	N.	Note Nota HOTa	A	B	C
1	EAA0382G00A	ALU MEASUREMENT UNIT L ALU GRUPPO DI MISURA L ALU УЗЕЛ ИЗМЕРЕНИЯ	ALU GROUPE DE MESURE L ALU GRUPO DE MEDIDA L	ALU MESSEINHEIT L CONJUNTO SISTEMA DE MEDIDA L	1	P-CLAMP	X		
1	EAA0392G39A	ALU UL MEASUREMENT UNIT ALU GRUPPO DI MISURA UL ALU УЗЕЛ ИЗМЕРЕНИЯ UL	ALU GROUPE DE MESURE UL ALU GRUPO DE MEDIDA UL	ALU MESSEINHEIT UL CONJUNTO SISTEMA DE MEDIDA UL	1	P-CLAMP US ONLY	X		
1	EAA0393G05A	ALU MEASUREMENT UNIT L ALU GRUPPO DI MISURA L ALU УЗЕЛ ИЗМЕРЕНИЯ	ALU GROUPE DE MESURE L ALU GRUPO DE MEDIDA L	ALU MESSEINHEIT L CONJUNTO SISTEMA DE MEDIDA L	1	P-CLAMP Long cable	X		
2	2-59266A	MOTOR INCL. CONNECTOR Y2K MOTORE CON CONNETTORE Y2K ДВИГАТЕЛЬ С РАЗЪЕМОМ Y2K	MOTEUR MOTOR CON CONECTOR Y2K	MOTOR MIT Y2K-VERBINDER MOTOR COM CONECTOR Y2K	1		X		
2	2-59366A	UL MOTOR INCL. CONNECTOR Y2K UL MOTORE CON CONNETTORE Y2K UL ДВИГАТЕЛЬ С РАЗЪЕМОМ Y2K	UL MOTEUR UL MOTOR CON CONECTOR Y2K	UL MOTOR MIT Y2K-VERBINDER UL MOVIM.R COM CONECTOR Y2K	1	US ONLY WS 120W	X		
2	2-67766A	MOTOR INCL. CONNECTOR Y2K MOTORE CON CONNETTORE Y2K ДВИГАТЕЛЬ С РАЗЪЕМОМ Y2K	MOTEUR MOTOR CON CONECTOR Y2K	MOTOR MIT Y2K-VERBINDER MOTOR COM CONECTOR Y2K	1	Long cable	X		
3	EAM0005D08A	MOTOR PULLEY PULEGGIA MOTORE ШКИВ ЭЛЕКТРОДВИГАТЕЛЯ	POULIE MOTEUR POLEA MOTOR	MOTORSCHIEBE POLIA MOVIM.R	1		X		
4	EAM0061G82A	UNIT MOTOR SPACER DISTANZIALE GRUPPO MOTORE РАСПОРКА ДВИГАТЕЛЯ УЗЛА	PIÈCE D'ÉCARTEMENT DU MOTEUR DISTANCIADOR MOTOR GRUPO	MOTOR-DISTANZSTÜCK EINHEIT CASQUILHO MOTOR	4	P-CLAMP	X		
5	1-28410	SCREW VITE ВИНТ	VIS TORNILLO	SCHRAUBE PARAFUSO	1	M6X8 915	X		
6	8-3531	BELT CINGHIA РЕМЕНЬ	COURROIE CORREA	RIEMEN CORREIA	1	5PJ711 7867	X	X	
7	EAA0344G00A	OPTO-ELECTRONIC UNIT SCHEDE OPTO-ENCODER CON LENTE БЛОК ОПТО-ЭНКОДЕРА С ЛИНЗОЙ	CARTE OPTO-ENCODER AVEC LENTILLE TARJETA OPTO-ENCODER CON LENTE	OPTOELEKTRONIKKARTE MIT LINSE CONJUNTO OPTO-ENCODER COM LENTE	1		X	X	
8	EAC0094G11A	ENCODER BOARD PROTECTION PROTEZIONE SCHEDE ENCODER ЗАЩИТА ПЛАТЫ ЭНКОДЕРА	PROTECTION CARTE ENCODER PROTECCIÓN TARJETA ENCODER	SCHUTZ ENCODERPLATINE PROTEÇÃO PLACA ENCODER	1		X		
9	1-9641	WASHER RONDELLA ШАЙБА	RONDELLE ARANDELA	UNTERLEGSCHIEBE ARRUELA	1	D4X9X0,8 ISO 7089	X		
10	1-35006A	SCREW VITE ВИНТ	VIS TORNILLO	SCHRAUBE PARAFUSO	1	M4X20 7985	X		
11	EAM0021D18A	MOTOR PULLEY PULEGGIA MOTORE ШКИВ ЭЛЕКТРОДВИГАТЕЛЯ	POULIE MOTEUR POLEA MOTOR	MOTORSCHIEBE POLIA MOVIM.R	1		X		
12	EAM0005D64A	ENCODER BAR CODE CODICE A BARRE ENCODER КОДИРОВЩИК ШТРИХ-КОДА	CODE A BARRES ENCODEUR CÓDIGO DE BARRAS ENCODER	ENCODER-STRICHCODE CÓDIGO DE BARRAS/ENCODER	1		X		
13	EAA0307G36A	REPLACEMENT KIT "P" KIT SOSTITUZIONE "P" КОМПЛЕКТ ЗАМЕНЫ "P"	KIT DE REMPLACEMENT "P" KIT DE SUSTITUCIÓN "P"	AUSTAUSCHSATZ "P" KIT DE SUBSTITUIÇÃO "P"	1		X		

A available - disponible - vorhanden - beschikbaar - tillgänglig
disponibile - disponible - disponivel - Доступно

B on request - sur demande - auf Antrag - op aanvraag - på begäran
a richiesta - a petición - no pedido - По запросу

C suggested - suggeré - vorgeschlagene - aanbevolen - föreslog
consigliato - sugerido - sugerido - Предлагается

Pos	Code	Designation Designazione ОПИСАНИЕ	Désignation Designación Benämning	Bezeichnung Designação	N.	Note Nota HOTa	A	B	C
14	EAW0240G67A	CABLE WITHOUT TEMP. SENSOR CAVO SENZA SENSORE TEMPERATURA КАБЕЛЬ БЕЗ ТЕМПЕРАТУРНОГО ДАТЧИКА	CÂBLE SANS CAPTEUR DE TEMPER. CABLE SIN SENSOR TEMPERATURA	KABEL OHNE TEMPERATURFÜHLER CABO SEM SENSOR DE TEMP.	1		X		X
14	EAW0282G49A	CABLE WITHOUT TEMP. SENSOR CAVO SENZA SENSORE TEMPERATURA КАБЕЛЬ БЕЗ ТЕМПЕРАТУРНОГО ДАТЧИКА	CÂBLE SANS CAPTEUR DE TEMPER. CABLE SIN SENSOR TEMPERATURA	KABEL OHNE TEMPERATURFÜHLER CABO SEM SENSOR DE TEMP.	1	6300-2p	X		X
15	EAA0260D59A	TRANSDUCER TRASDUTTORE ПРЕОБРАЗОВАТЕЛЬ	CAPTEUR TRANSDUCTOR	MESSGEBER TRANSDUTOR	2		X		X
16	1-17709	SCREW TCEI 8X20 8G VITE TCEI ВИНТ TCEI M8X20	VIS CHc TORNILLO TCEI	ZYLINDERSCHR.B.M.ISKT.M8X20-8.8-A2J PARAFUSO TCEI	6	M8X100 8K ISO 4762	X		
17	1-16641	Washer plain Rondella piana ШАЙБА	Rondelle plate Arandela plana	Unterlegscheibe, flach ARRUELA plana	4	D. 6,4	X		
18	1-46701A	HEX HEAD SCREW VITE TE ВИНТ	VIS H TORNILLO TE	SECHSKANTSCHRAUBE PARAFUSO TE	4	M6X16 933	X		
19	EAA0307G35A	BRAKE DISC REPAIR KIT KIT FRENO DI POSIZIONAMENTO РЕМКОМПЛЕКТ ДИСКА ТОРМОЗА	KIT FREIN DE POSITIONNEMENT KIT FRENO DE POSICIONAMIENTO	REPARATURSATZ POSITIONSBREMSE KIT FREIO DE POSICIONAMENTO	1		X		
19	EAA0383G85A	BRAKE DISC REPAIR KIT KIT FRENO DI POSIZIONAMENTO РЕМКОМПЛЕКТ ДИСКА ТОРМОЗА	KIT FREIN DE POSITIONNEMENT KIT FRENO DE POSICIONAMIENTO	REPARATURSATZ POSITIONSBREMSE KIT FREIO DE POSICIONAMENTO	1	Long wire	X		
20	EAP0201D20A	ENCODER BOARD COMPLETE SCHEDE ENCODER COMPLETA ПЛАТА ЭНКОДЕРА В КОМПЛЕКТЕ	CARTE ENCODEUR COMPLETE TARJETA ENCODER COMPLETA	ENCODER-PLATINE KOMPLETT PLACA ENCODER COMPLETA	1		X		X
21	EAA0382G01A	POWER CLAMP FLANGE L FLANGIA "POWER CLAMP" L ФЛАНЕЦ ДЛЯ ЭЛ.-МЕХ. ЗАЖИМА	FLASQUE "POWER CLAMP" L BRIDA "POWER CLAMP" L	FLANSCH FÜR POWER CLAMP L FLANGE "POWER CLAMP" L	1		X		
22	EAA0382G02A	PULL-SHAFT COMPLETE L TIRANTE COMPLETO L ТЯГА В КОМПЛЕКТЕ	AXE COMPLET L TIRANTE COMPLETO L	ZUGSTANGE KOMPLETT L TIRANTE COMPLETO L	1		X		
23	EAA0384G71A	P-CLAMP FLANGE COMPLETE FLANGIA P-CLAMP COMPLETA ФЛАНЕЦ P-ЗАЖИМА В КОМПЛЕКТЕ	FLASQUE POWER CLAMP COMPLET BRIDA P-CLAMP COMPLETA	FLANSCH FÜR P-CLAMP KOMPLETT FLANGE "POWER CLAMP" COMPLETO	1		X		
24	EAA0328G16A	TRANSDUCER FIXING UNIT GRUPPO FISSAGGIO PIEZO ФИКСАТОР ПРЕОБРАЗОВАТЕЛЯ	MOYENS DE FIXATION DU CAPTEUR GRUPO FIJACIÓN PIEZA	MESSGEBER-BEFESTIGUNGSEINHEIT CONJUNTO FIXAÇÃO PEÇA	1		X		X
25	EAA0307G37A	BAYONET FITTING FISSAGGIO A BAIONETTA БАЙОНЕТНЫЙ ФИКСАТОР	DISPOSITIFS ATTACHE BAÏONNETTE DISCO DE BAYONETA DE FIJACIÓN	BAJONETTSCHIEBENBEFESTIGUNG FIXAÇÃO A BAIONETA	1			X	
26	EAM0051G25A	POWER CLAMP SPACER RING ANELLO DISTANZIALE POWER CLAMP КОЛЬЦО ЭЛ.-МЕХ. ЗАЖИМА	BAGUE D'ECARTEMENT POWER CLAMP ANILLO DISTANCIADOR	POWER CLAMP DISTANZRING ANEL DISTANCIADOR POWER CLAMP	1	40x17		X	
27	EAK0329G15A	BOARD SUPPORT KIT KIT SUPPORTO SCHEDE КРОНШТЕЙН ПЛАТЫ	KIT SUPPORT CARTE KIT SOPORTE TARJETA	HALTERUNG DER KARTE KIT SUPORTE PLACA	1			X	

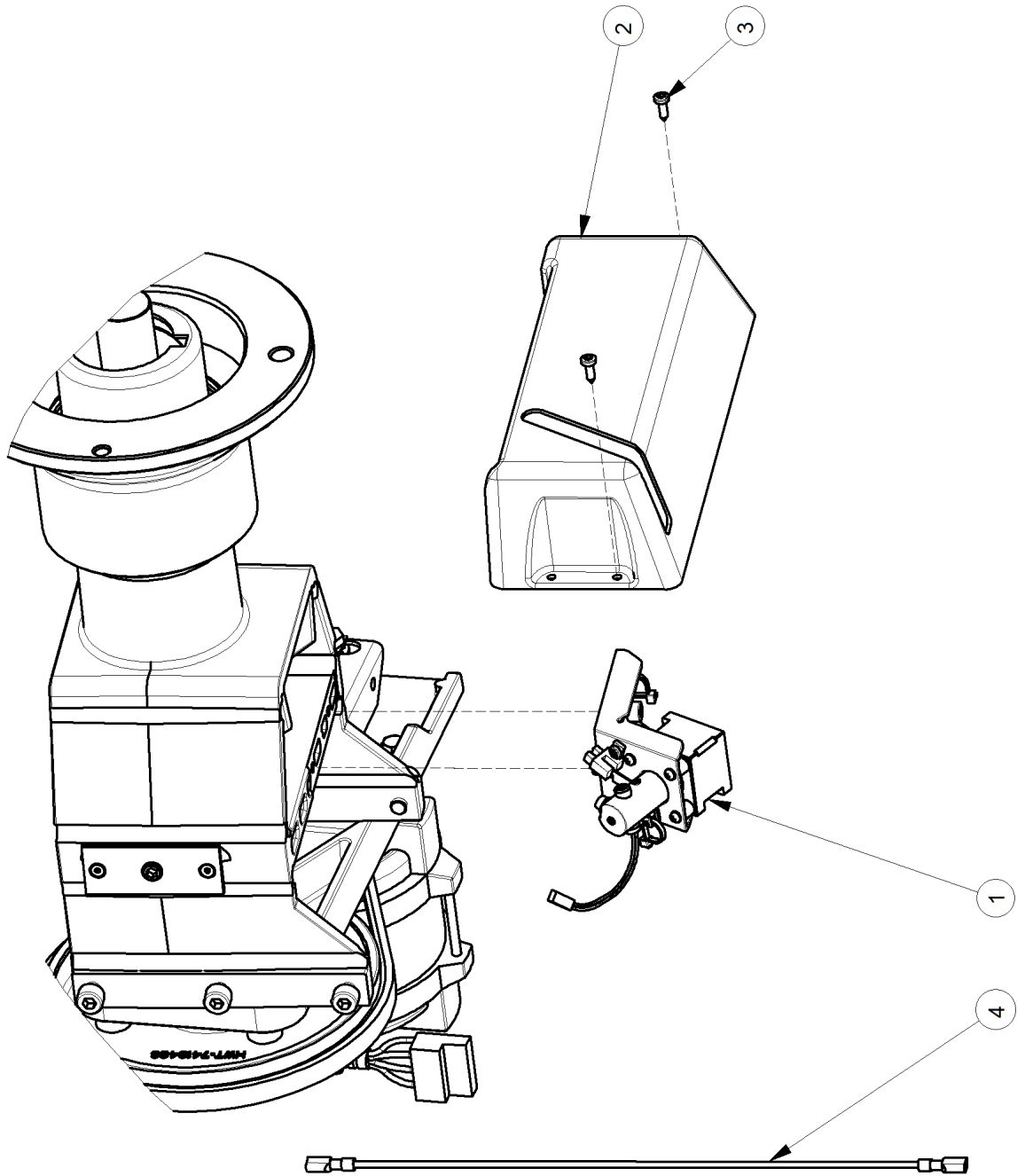

Pos	Code	Designation Designazione ОПИСАНИЕ	Désignation Designación Benämning	Bezeichnung Designação	N.	Note NOTa	Nota	A	B	C
1	EAA0394G93A	LASER POINTER WITH LONG CABLES PUNTATORE LASER CON CAVI ALLUNGATI ЛАЗЕРНЫЙ УКАЗАТЕЛЬ Длинный кабель	POINTEUR LASER CABLES LONGS PUNTERO LASER CABLES LARGOS	LASERPOINTER KABEL LANG APONTADOR LASER CABOS LONGOS	1			X		X
2	EAC0103G31A	LASER POINTER COVER COPERCHIO PUNTATORE LASER КОЖУХ ЛАЗЕРНОГО УКАЗАТЕЛЯ	COUVERCLE POINTEUR LASER TAPA PUNTERO LASER	ABDECKUNG F. LASERPOINTER TAMPA APONTADOR LASER	1	RAL9005		X		
3	1-22623A	SCREW, PHIL PAN H.TAPP. VITE AUTOF. ВИНТ С ГОЛОВКОЙ PHILIPS	VIS AUTOTAR. TORNILLO AUTORR.	SCHRAUBE, SELBSTSCHNEIDEND PARAFUSO AUTO-ROSC.	2	D3,9X13 TCB ZB 7981 C		X		
4	EAW0276G28A	LASER POINTER EXTENSION WIRE CAVO PROLUNGA LASER PUNTATORE УДЛИНИТЕЛЬ ЛАЗЕРНОГО УКАЗАТЕЛЯ	CÂBLE RALLONGE LASER POINTEUR CABLE ALARGADOR PUNTERO LÁSER	VERLÄNGERUNGSKABEL LASERPOINTER CABO DE EXTENSÃO APONTADOR LASER	1			X		X

A available - disponible - vorhanden - beschikbaar - tillgänglig
disponibile - disponible - disponivel - Доступно

B on request - sur demande - auf Antrag - op aanvraag - på begäran
a richiesta - a petición - no pedido - По запросу

C suggested - suggeré - vorgeschlagene - aanbevolen - föreslog
consigliato - sugerido - sugerido - Предлагается

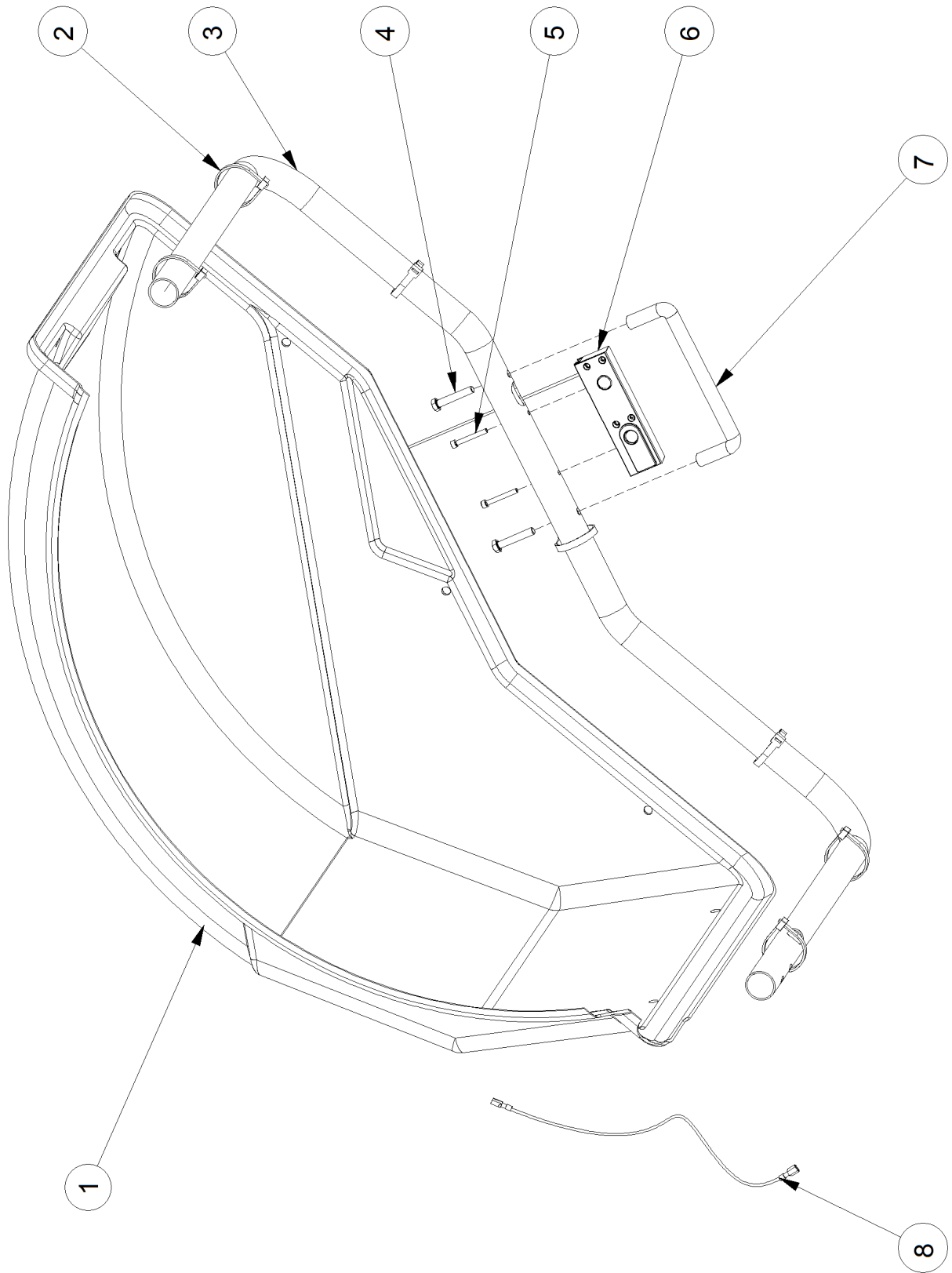

Pos	Code	Designation Designazione ОПИСАНИЕ	Désignation Designación Benämning	Bezeichnung Designação	N.	Note Nota HOTa	A	B	C
1	EAC0100G21A	WHEEL GUARD 42" PROTEZIONE RUOTA 42" ЗАЩИТНЫЙ КОЖУХ 42"	PROTECTION ROUE 42" PROTECCIÓN RUEDA 42"	RADSCHUTZ, 42" PROTEÇÃO RODA 42"	1	42"	X		
2	5-03345A	CABLE TIE FASCETTA TUBI OLIO ХОМУТ КАБЕЛЯ	COLLIER TUBES HUILE ABRAZADERA TUBOS ACEITE	SHELLE F. ÖLSCHLÄUCHE FAIXA TUBOS ÓLEO	7	L.350	X		
3	EAM0076G34A	WHEEL GUARD PIPE TUBO PROTEZIONE RUOTA ТРУБА ЗАЩИТНОГО КОЖУХА	TUBE PROTECTION ROUE TUBO PROTECCIÓN RUEDA	SCHLAUCH F. RADSCHUTZ TUBO PROTEÇÃO RODA	1		X		
4	1-19101A	SCREW, HEXAG. VITE TE БОЛТ	VIS H TORNILLO TE	SECHSKANTSCHRAUBE PARAFUSO TE	2	M8X45 8.8 BR	X		
5	1-15509	SCREW VITE TCEI ВИНТ	VIS CHc TORNILLO TCEI	ZYLINDERSCHR. M/INNENSECHSKANT PARAFUSO TCEI	2	TCEI 5X40 8G	X		
6	EAA0439G97A	ASSY SONAR FOR PIPE GRUPPO SONAR PER TUBO СОНАР В СБОРЕ	GROUPE SONAR GRUPO SONAR	SONAREINHEIT GRUPO SONAR	1	DIGITAL VERSION 10" TOUCHSCREE	X		X
6	EAA0440G00A	ASSY SONAR FOR PIPE GRUPPO SONAR PER TUBO СОНАР В СБОРЕ	GROUPE SONAR GRUPO SONAR	SONAREINHEIT GRUPO SONAR	1	VIDEO VERSION	X		X
7	8-09233A	PLASTIC HANDLE MANIGLIA PER PROT. RUOTA ПЛАСТИКОВАЯ РУЧКА	POIGNEE POUR PROT. ROUE EMPUÑADURA PARA PROT. RUEDA	GRIFF F. RADSCHUTZ MANÍPULO PARA PROT. RODA	1		X		
8	EAW0283G76A	SONAR SENSOR EXTENSION CABLE PROLUNGA CAVO SENSORE SONAR УДЛИНИТЕЛЬ КАБЕЛЯ СОНАРА	CÂBLE SENSOR SONAR (EXTENSION) CABLE SENSOR SONAR (EXTENSION)	SONAR-SENSORSKABEL (EXTENSION) CABO SENSOR SONAR (EXTENSION)	1	VIDEO VERSION	X		X
8	EAW0283G81A	SONAR SENSOR IIC EXTENSION CABLE PROLUNGA SENSORE SONAR IIC УДЛИНИТЕЛЬ КАБЕЛЯ СОНАРА IIC	CÂBLE SENSOR SONAR IIC (EXTENSION) CABLE SENSOR SONAR IIC (EXTENSION)	SONAR-SENSORSKABEL IIC (EXTENSION) CABO SENSOR SONAR IIC (EXTENSION)	1	DIGITAL VERSION	X		X

EAZ0088G23A

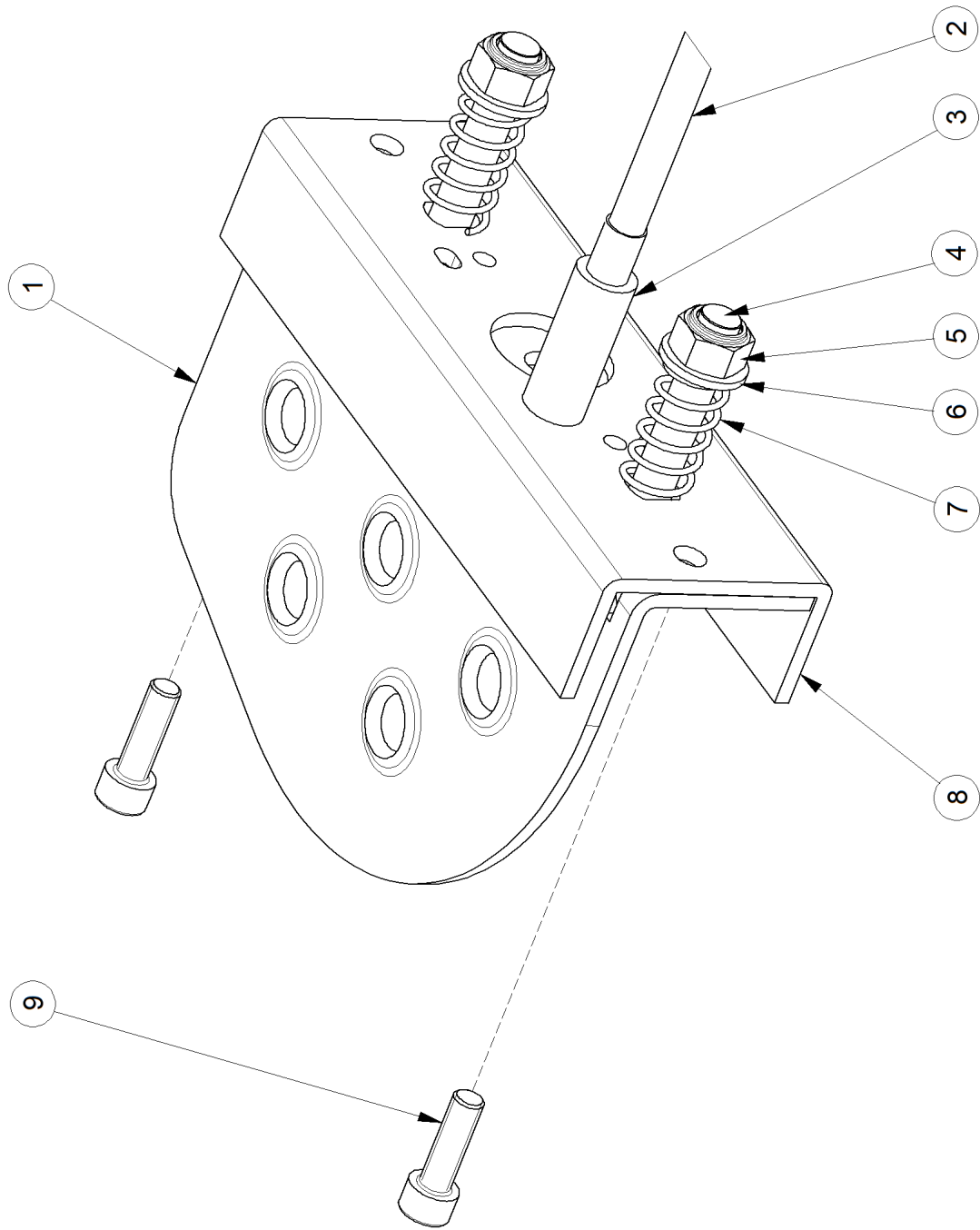

05/2014

Pos	Code	Designation Designazione ОПИСАНИЕ	Désignation Designación Benämning	Bezeichnung Designação	N.	Note Nota HOTa	A	B	C
1	EAS2020P20A	Pedal Pedale ПЕДАЛЬ	Pédale Pedal	Pedal Pedal	1		X		
2	EAA0344G15A	Bowden cable assy Cavo pedale Трос педали	Cable pédale Cable pedal	Bowden Bremskabel Cabo pedal	1		X		
3	EAM0053G06A	Spacer Distanziale Втулка	Pièce d'écartement DISTANCIADOR	Distanzstück Distanciador	1		X		
4	1-18209	Screw Vite ВИНТ	Vis Tornillo	Schraube Parafuso	2	M8 x 45 912	X		
5	1-10033	HEX NUT PREVAILING TORQUE M8 DADO M8 AUTO.BASSO CL6 ГАЙКА M8	ECROU M8 5S TUERCA M8 5S AUTOBLOQ.BAJO	MUTTER, SELBSTSICHERND M8 PORCA M8 AUTO.BAIXO CL6	2		X		
6	1-10041	WASHER D.8 RONDELLA P.D.8 Z.BIANCA ШАЙБА D 8	RONDELLE DIAM 8 ARANDELA PLANA D.8 GALVANIZ.	SCHEIBE B 8,4 -A2J ARRUELA P.D.8 Z.BRANCA	2	D8-UNI6592-69 DIN 125	X		
7	1-06768A	Compression spring Molla a compressione Пружина сжатия	Ressort à pression MUELLE de presión	Druckfeder Mola de compressão	2	2098	X		
8	EAS2027G18A	Pedal holder Supporto Pedale Кронштейн педали	Support pédale Soporte pedal	Pedalhalter SUPORTE PEDAL	1		X		
9	1-16409	Screw Vite ВИНТ	Vis Tornillo	Schraube Parafuso	2	M6 x 20 912		X	

A available - disponible - vorhanden - beschikbaar - tillgänglig
disponibile - disponibile - disponível - Доступно

B on request - sur demande - auf Antrag - op aanvraag - på begäran
a richiesta - a petición - no pedido - По запросу

C suggested - suggeré - vorgeschlagene - aanbevolen - föreslog
consigliato - sugerido - sugerido - Предлагается

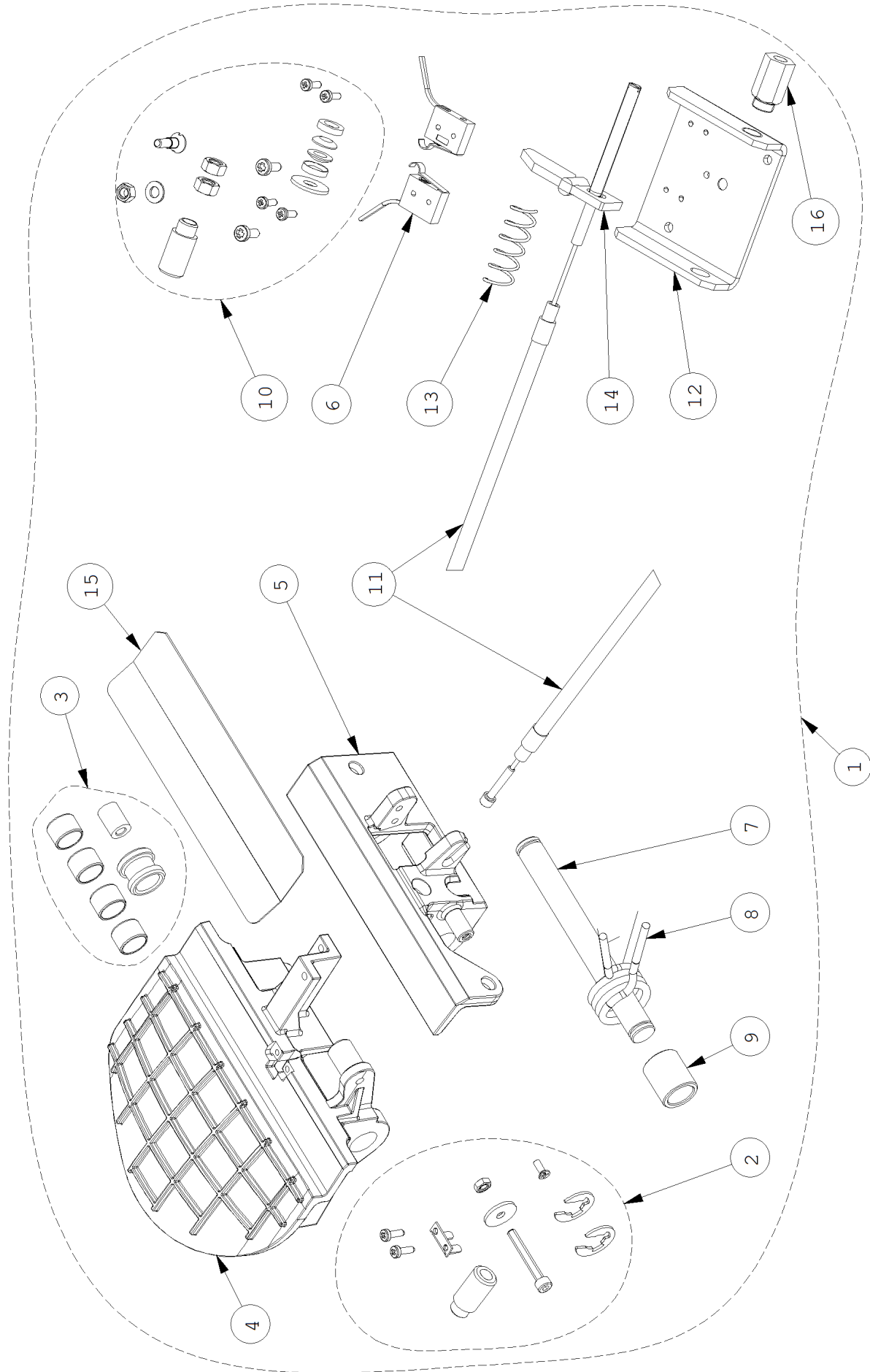

Pos	Code	Designation Designazione ОПИСАНИЕ	Désignation Designación	Bezeichnung Designação	N.	Note Nota HOTa	A	B	C
1	EAA0409G98A	ALU BRAKE PEDAL 2 SWITCHES PEDALE FRENO ALLUMINIO 2 MICRO UL ПЕДАЛЬ ТОРМОЗА ALU 2 ПОЛОЖЕНИЯ UL BE	PEDALE FREIN ALUMINIUM 2 MICRO PEDAL FRENO ALUMINIO 2 MICRO	BREMSPEDAL ALUMINIUM 2 MIKRO UL PEDAL TRAVÃO ALUMÍNIO 2 MICRO UL	1	UL VERSION	X		X
2	EAK0315G94A	SCREWS UL ALU BRAKE PEDAL SET KIT BULLONERIA PEDALE FRENO UL ВИНТЫ КРЕПЛЕНИЯ ПЕДАЛИ ТОРМОЗА ALU :	KIT BOULONNERIE PEDALE FREIN UL KIT PERNOS PEDAL FRENO UL	SCHRAUBEN-KIT BREMSPEDAL UL KIT PARAFUSOS PEDAL TRAVÃO UL	1	UL VERSION	X		X
3	EAK0306G92A	BUSHES FOR ALU BRAKE PEDAL SET KIT BOCCOLE PEDALE FRENO IN ALLUMINIO ВТУЛКИ ДЛЯ ПЕДАЛИ ALU	KIT DOUILLES PEDALE FREIN EN ALUMINIUM KIT CASQUILLOS PEDAL FRENO DE ALUMINIO	BUCHSENSATZ BREMSPEDAL ALUMINIUM KIT ARRUELAS PEDAL FREIO DE ALUMÍNIO	1		X		
4	EAM0122G48A	MACHINED PEDAL PEDALE LAVORATO ПЕДАЛЬ ОБРАБОТАННАЯ	PEDALE USINÉ PEDAL TRABALHADO	BREMSPEDAL BEARBEITET PEDAL TRABALHADO	1			X	
5	EAM0181G72A	BRAKE PEDAL SUPPORT FINISHED SUPPORTO FINITO КРОНШТЕЙН ПЕДАЛИ ТОРМОЗА	SUPPORT FINI SOPORTE ACABADO	FERTIGES PEDALHALTERUNG SUORTE ACABADO	1			X	
6	2-07661A	MICRO SWITCH MICRO INTERRUPTORE МИКРОВЫКЛЮЧАТЕЛЬ	MICRO-RUPTEUR MICROINTERRUPTOR	MIKROSCHALTER MICRO INTERRUPTOR	2		X		X
7	EAM0046G39A	PEDAL PIN PERNO ANCORAGGIO PEDALE ШТИФТ КРЕПЛЕНИЯ ПЕДАЛИ	GOUPILLE DE PÉDALE PERNO DE ANCLAJE DEL PEDAL	PEDALVERANKERUNGSSTIFT PINO DO PEDAL	1			X	
8	EAM0048G78A	SPRING, PEDAL SWITCH MOLLA PEDALE INTERRUPTORE ПРУЖИНА	RESSORT, PEDAL INTERRUPTEUR MUELLE PEDAL INTERRUPTOR	FEDER F. PEDALSCHALTER MOLA, INTERRUPTOR PEDAL	1		X		X
9	EAM0051G96A	SPRING BUSHING BOCCOLA DELLA MOLLA ПРУЖИНА	DOUILLE DE RESSORT CASQUILLO DEL MUELLE	FEDERBUCHSE BUCHA DA MOLA	1			X	
10	EAK0315G95A	SCREWS FOR ACTUATOR ALU BRAKE PEDAL KIT BULLONERIA ATTUATORE FRENO UL ВИНТЫ ПРИВОДА ПЕДАЛИ ТОРМОЗА ALU UL	KIT BOULONNERIE ACTIONNEUR PEDALE KIT PERNOS ACTUADOR PEDAL	SCHRAUBEN-KIT UL BREMSPEDASTELLGLIED KIT PARAFUSOS ATUADOR TRAVÃO UL	1			X	
11	EAA0344G15A	Bowden cable assy Cavo pedale Трос педали	Cable pédale Cable pedal	Bowden Bremskabel Cabo pedal	1		X		
12	EAS2153G49A	MICROSWITCH SUPPORT LAMIERA SUPPORTO MICROSWITCH КРОНШТЕЙН МИКРОПЕРЕКЛЮЧАТЕЛЯ	SUPPORT MICRO-RUPTEUR SOPORTE MICROINTERRUPTOR	MIKROSCHALTERSHALTERUNG CHAPA SUPORTE MICROINTERRUPTOR	1		X		
13	1-06768A	Compression spring Molla a compressione Пружина сжатия	Ressort à pression MUELLE de presión	Druckfeder Mola de compressão	1	2098	X		
14	EAM0153G24A	ACTUATOR ATTUATORE РЫЧАГ	ACTIONNEUR ACTUADOR	STELLGLIED GRUPO ATUADOR	1			X	
15	EAL0443G72A	PROTECTIVE LABEL ADESIVO PROTETTIVO ЗАЩИТНАЯ НАКЛЕЙКА	ADHÉSIF PROTECTEUR ADHESIVO DE PROTECCIÓN	KLEBESCHUTZSCHILD ADESIVO DE PROTEÇÃO	1		X		X
16	EAM0140G21A	THREADED BUSH BUSSOLA FILETTATA ВТУЛКИ РЕЗЬБОВОЙ	DOUILLE FILETEE CASQUILLO ROSCADO	GEWINDE BUCHSE BUSSOLA ROSQUEADA	1		X		

A available - disponible - vorhanden - beschikbaar
disponibile - disponible - disponivel - Доступно

B on request - sur demande - auf Antrag - op aanvraag
a richiesta - a petición - no pedido - По запросу

C suggested - suggeré - vorgeschlagene - aanbevolen
consigliato - sugerido - sugerido - Предлагается

EAZ0033G99A.B

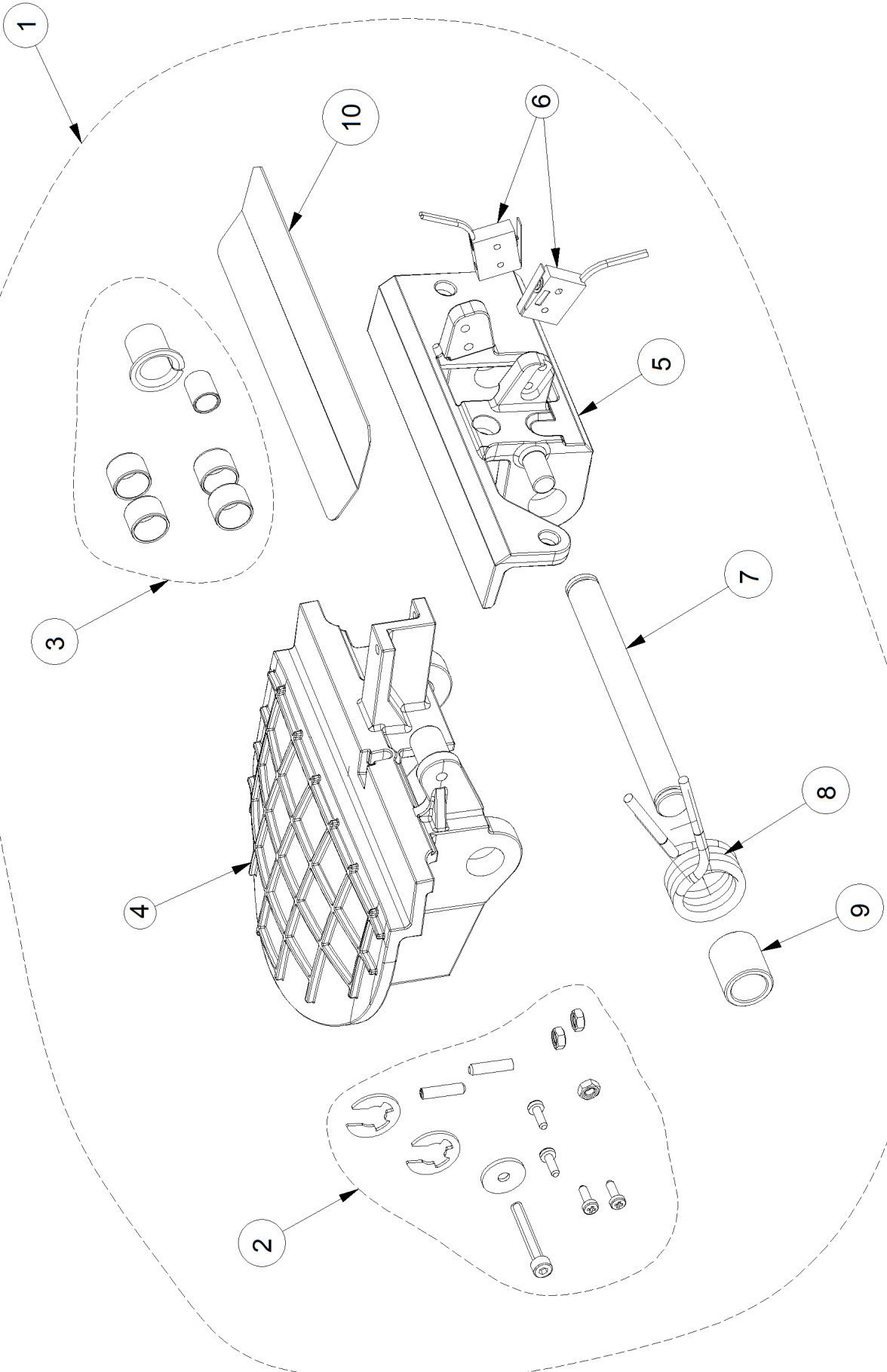

10/2013

Pos	Code	Designation Designazione ОПИСАНИЕ	Désignation Designación Benämning	Bezeichnung Designação	N.	Note Nota HOTa	A	B	C
1	EAA0372G98A	ALU BRAKE PEDAL 2 SWITCHES PEDALE FRENO ALLUMINIO 2 MICRO ПЕДАЛЬ ALU 2 ПОЛОЖЕНИЯ	PEDALE FREIN ALUMINIUM 2 MICRO PEDAL FRENO ALUMINIO 2 MICRO	BREMSPEDAL ALUMINIUM 2 MIKRO PEDAL FREIO ALUMINIO 2 MICRO	1	POWER CLAMP	X		X
1	EAA0426G47A	ALU BRAKE PEDAL 2 SWITCHES 2.8 m PEDALE FRENO ALLUMINIO 2 MICRO 2.8 m ПЕДАЛЬ ALU 2 ПОЛОЖЕНИЯ 2.8	PEDALE FREIN ALUMINIUM 2 MICRO 2.8 m PEDAL FRENO ALUMINIO 2 MICRO 2.8 m	BREMSPEDAL ALUMINIUM 2 MIKRO 2.8 m PEDAL FREIO ALUMINIO 2 MICRO 2.8 m	1	Long cable	X		X
2	EAK0306G90A	SCREWS 2 SWITCHES ALU BRAKE PEDAL SE KIT BOULONNERIE KIT BULLONERIA PEDALE FRENO AL 2 MICRC БОЛТЫ ПЕДАЛИ	KIT DOUILLES PEDALE FREIN EN ALUMINIUM KIT CASQUILLOS PEDAL FRENO DE ALUMINIC	SCHRAUBSATZ BREMSPEDAL AL 2 MIKRO KIT PARAFUSOS PEDAL FREIO ALE 2 MICRO	1			X	
3	EAK0306G92A	BUSHES FOR ALU BRAKE PEDAL SET KIT BOCCOLE PEDALE FRENO IN ALLUMINIO ВТУЛКИ ДЛЯ ПЕДАЛИ ALU	KIT DOUILLES PEDALE FREIN EN ALUMINIUM KIT CASQUILLOS PEDAL FRENO DE ALUMINIC	BUCHSENSATZ BREMSPEDAL ALUMINIUM KIT ARRUELAS PEDAL FREIO DE ALUMÍNIO	1		X		
4	EAM0081G41A	BRAKE PEDAL FINISHED PEDALE FINITO ПЕДАЛЬ ТОРМОЗА В СБОРЕ	PEDALE FINIE PEDAL ACABADO	FERTIGES PEDAL PEDAL ACABADO	1			X	
5	EAM0081G42A	BRAKE PEDAL SUPPORT FINISHED SUPPORTO FINITO КРОНШТЕЙН ПЕДАЛИ ТОРМОЗА	SUPPORT FINI SOPORTE ACABADO	FERTIGES PEDALHALTERUNG SUPORTE ACABADO	1			X	
6	2-15061A	MICROSWITCH *BURGESS MICROINT. *BURGESS МИКРОВЫКЛЮЧАТЕЛЬ	CONTACT *BURGESS MICROINT. *BURGESS	MIKROSCHALTER *BURGESS MICROINT. *BURGESS	2	V4NC A10 LEVER	X		X
6	2-16061A	MICROSWITCH WIRES 2800MM MICROINT. ATTUATORE A30-CAVO 2800MM МИКРОВЫКЛЮЧАТЕЛЯ	MICROINTERRUPTEUR MICROINTERRUPTOR	MIKROSCHALTER MICROINTERRUPTOR	2	Long cable V4NC A30 LEVER	X		
7	EAM0046G39A	PEDAL PIN PERNO ANCORAGGIO PEDALE ШТИФТ КРЕПЛЕНИЯ ПЕДАЛИ	GOUPILLE DE PÉDALE PERNO DE ANCLAJE DEL PEDAL	PEDALVERANKERUNGSTIFT PINO DO PEDAL	1			X	
8	EAM0048G78A	SPRING, PEDAL SWITCH MOLLA PEDALE INTERRUPTORE ПРУЖИНА	RESSORT, PEDAL INTERRUPTEUR MUELLE PEDAL INTERRUPTOR	FEDER F. PEDALSCHALTER MOLA, INTERRUPTOR PEDAL	1		X		X
9	EAM0051G96A	SPRING BUSHING BOCCOLA DELLA MOLLA ПРУЖИНА	DOUILLE DE RESSORT CASQUILLO DEL MUELLE	FEDERBUCHSE BUCHA DA MOLA	1			X	
10	EAL0443G72A	PROTECTIVE LABEL ADESIVO PROTETTIVO ЗАЩИТНАЯ НАКЛЕЙКА	ADHÉSIF PROTECTEUR ADHESIVO DE PROTECCIÓN	KLEBESCHUTZSCHILD ADESIVO DE PROTEÇÃO	1		X		X

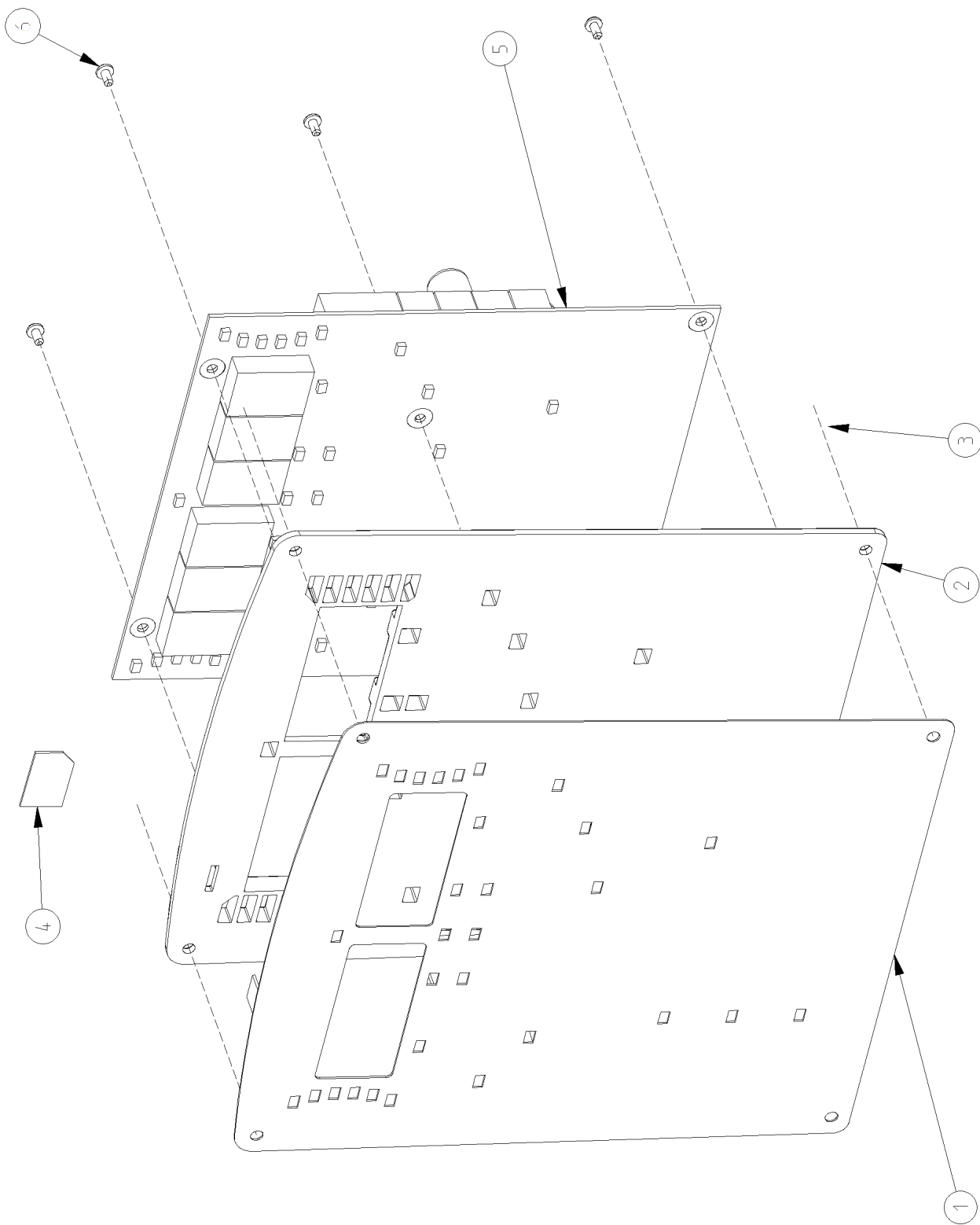

Pos	Code	Designation Designazione ОПИСАНИЕ	Désignation Designación Benämning	Bezeichnung Designação	N.	Note Nota HOTa	A	B	C
1	EAL0413G15A	JB PANEL MEMBRANE W/O START TARGA ADESIVA PANNELLO JB NO START ПЛЕНОЧНА ЯПАНЕЛЬ JB БЕЗ СТАРТА	MARQUAGE ADHESIF TABLEAU JB NO START PLACA ADHESIVA PANEL JB NO START	SELBSTKLEBENDES SCHILD JB-TAFEL KEIN S PLACA ADESIVA PAINEL JB NO START	1	JB W/O START	X		
1	EAL0425G30A	SNAP-ON PANEL MEMBRANE TARGA ADESIVA PANNELLO SNAP-ON ПЛЕНОЧНАЯ ПАНЕЛЬ SNAP-ON БЕЗ СТАРТА	PLAQUE ADHESIVE TABLEAU SNAP-ON PLACA ADHESIVA PANEL SNAP-ON	SELBSTKLEBENDES SCHILD SNAP-ON-TAFEL PLACA ADESIVA PAINEL SNAP-ON	1	SNAP-ON		X	
1	EAL0425G32A	JB PANEL MEMBRANE TARGA ADESIVA PANNELLO JB ПЛЕНОЧНАЯ ПАНЕЛЬ JB БЕЗ СТАРТА	PLAQUE ADHESIVE TABLEAU JB PLACA ADHESIVA PANEL JB	SELBSTKLEBENDES SCHILD JB-TAFEL PLACA ADESIVA PAINEL JB	1	JB	X		
1	EAL0425G55A	HF PANEL MEMBRANE TARGA ADESIVA PANNELLO HF ПЛЕНОЧНАЯ ПАНЕЛЬ HF БЕЗ СТАРТА	PLAQUE ADHESIVE TABLEAU HF PLACA ADHESIVA PANEL HF	SELBSTKLEBENDES SCHILD HF-TAFEL PLACA ADESIVA PAINEL HF	1	HF	X		
1	EAL0442G60A	PANEL MEMBRANE TARGA ADESIVA PANNELLO NEUTRO ПЛЕНОЧНАЯ ПАНЕЛЬ	PLAQUE ADHESIVE PLACA ADHESIVA	SELBSTKLEBENDES SCHILD PLACA ADESIVA	1	NEUTRAL	X		
2	EAC0099G62A	SMALL KEYBOARD SUPPORT SUPPORTO TATSTIERA SMALL ДЕРЖАТЕЛЬ КЛАВИАТУРЫ	SUPPORT CLAVIER PETIT SOPORTE TECLADO SMALL	TRÄGER KLEINE TASTATUR SUPORTE TECLADO PEQUENO	1		X		
3	EAM0075G37A	KEYBOARD GASKET GUARNIZIONE TASTIERA ПРОКЛАДКА КЛАВИАТУРЫ	GARNITURE CLAVIER JUNTA TECLADO	TASTATUR-DICHTUNG GUARNICAO TECLADO	1		X		
4	3-78426AF1	PROGRAMMED MMC / SD CARD MMC / SD CARD PROGRAMMATA MMC/SD КАРТА С ПРОГРАММОЙ	CARTE PROGRAMMÉE DE MMC/SD TARJETA MMC / SD PROGRAMADA	PROGRAMMIERTE KARTE MMC / SD CARTAO MMC / SD PROGRAMADO	1	B300,GEO7300	X		X
4	3-52226AF1	PROGRAMMED MMC / SD CARD MMC / SD CARD PROGRAMMATA MMC/SD КАРТА С ПРОГРАММОЙ	CARTE PROGRAMME DE MMC / SD TARJETA MMC / SD PROGRAMADA	PROGRAMMIERTE KARTE MMC / SD PLACA MMC / SD PROGRAMADO	1		X		X
5	EAP0290G50A1	INTEGRATED LED DISPLAY NEW GENERATION SCHEDE DISPLAY LED INTEGR. NUOVA GENERAZIONE ПЛАТА СВЕТОДИОДНОГО ДИСПЛЕЯ	CARTE AFFICHEUR LED INTEGR. NEW GENERATION TARJETA DISPLAY LED INTEGR. NEW GENERATION	INTEGR. LED DISPLAY KARTE NEW GENERATION CARTAO VISOR LED INTEGR. NEW GENERATION	1	B300, GEO 7300 NEW GENERATION	X		X
5	EAP0290G50B1	INTEGRATED LED DISPLAY JB DEPOPULATED SCHEDE DISPLAY LED INTEGR. JB RIDOTTA ПЛАТА СВЕТОДИОДНОГО ДИСПЛЕЯ	CARTE AFFICHEUR LED INTEGR. JB REDUCED TARJETA DISPLAY LED INTEGR. JB REDUCED	INTEGR. LED DISPLAY KARTE VERKLEINERTE CARTAO VISOR LED INTEGR. JB REDUZIDO	1	DEPOPULATED	X		X
6	1-17226A	SELF TAPPING SCREW VITE AUTOFILETTANTE ВИНТ САМОФИКСИРУЮЩИЙСЯ	VIS AUTO VISSANT TORNILLO AUTOFILETANTE	SCHNEIDSCHRAUBE PARAFUSO AUTOROSCANTE	5	D 3x6	X		

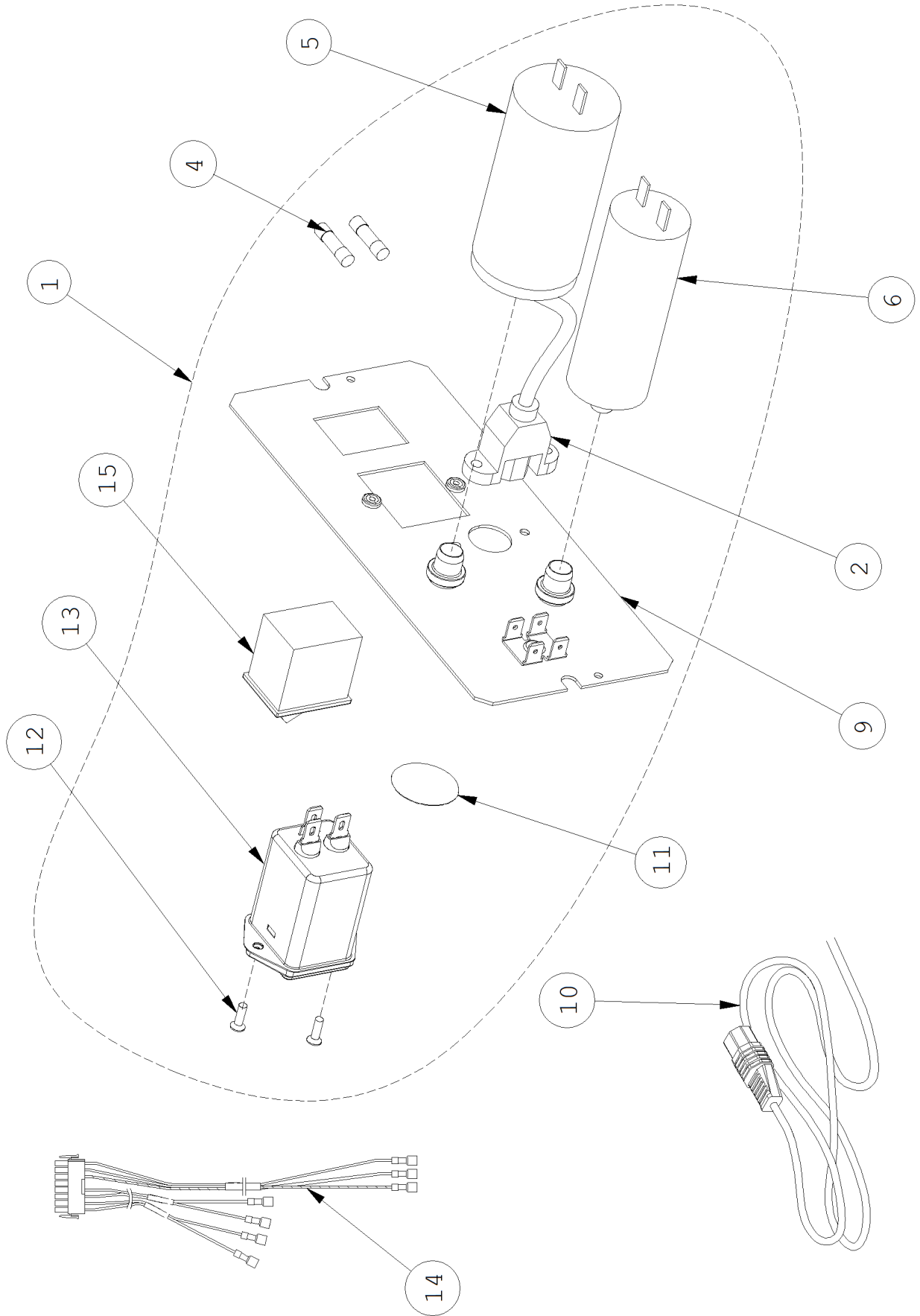

Pos	Code	Designation Designazione ОПИСАНИЕ	Désignation Designación Benämning	Bezeichnung Designação	N.	Note Nota HOTa	A	B	C
1	EAA0458G36A	ASSY POWER INLET GRUPPO INGRESSO ALIMENTAZIONE ВВОД ВВОДА ПИТАНИЯ	GROUPE ENTRÉE ALIMENTATION GRUPO ENTRADA ALIMENTACIÓN	EINHEIT EINGANG VERSORGUNG GRUPO ENTRADA ALIMENTAÇÃO	1		X		
1	EAA0481G95A	ASSY POWER INLET GRUPPO INGRESSO ALIMENTAZIONE Блок подачи питания	GROUPE ENTR. ALIMENTATION GRUPO ENTRADA ALIMENT.	EINHEIT EINGANG VERSORGUNG GRUPO ENTRADA ALIMENT.	1	Laser Pointer	X		
2	6-14722A	PANEL-MOUNT USB TYPE-B LONG CABLE CAVO USB B LUNGO DA PANNELLO КАБЕЛЬ ДЛИННЫЙ С РАЗЪЕМОМ USB-B	CABLE USB B LONG PUPITRE CABLE USB B LONGITUD DESDE PANEL	USB B-KABEL LANG VON TAFEL CABO USB B LONGO DO PAINEL	1	LONG	X		
4	2-21251A	FUSE FUSIBILE ПРЕДОХРАНИТЕЛЬ	FUSIBLE FUSIBLE SÄKRING	SICHERUNG FUSÍVEL	2	6,3A(T) 5x20	X		X
5	2-01529A	CAPACITOR CONDENSATORE КОНДЕНСАТОР	CONDENSATEUR CONDENSADOR	KONDENSATOR CONDENSADOR	1	20µF 400V	X		X
6	2-01429A	CAPACITOR CONDENSATORE КОНДЕНСАТОР	CONDENSATEUR CONDENSADOR	KONDENSATOR CONDENSADOR	1	10µF 400V	X		X
9	EAA0457G52A	POWER INLET PLATE GROUP GRUPPO PIATTO ALIMENTAZIONE ПЛАСТИНА БЛОКА ВВОДА ПИТАНИЯ	ENSEMBLE 'TÔLE CONNECTEUR ALIMENTATI CONJUNTO 'CHAPA CONECTOR ALIMENTACIÓ	BAUGRUPPE BLECH VERSORGUNGSSTECKEI CONJUNTO CHAPA CONECTOR ALIMENTAÇÃO	1		X		
10	EAW0240G14A	POWER SUPPLY CABLE CAVO DI ALIMENTAZIONE КАБЕЛЬ ПИТАНИЯ	CABLE SECTEUR CABLE ELÉCTRICO	NETZKABEL CABO DE ALIMENTAÇÃO	1	USA 115V	X		
10	EAW0240G13A	POWER SUPPLY CABLE CAVO DI ALIMENTAZIONE КАБЕЛЬ ПИТАНИЯ	CABLE SECTEUR CABLE ELÉCTRICO	NETZKABEL CABO DE ALIMENTAÇÃO	1	UK	X		
10	6-05221A	POWER CORD EUROPEAN CAVO ALIMENTAZIONE КАБЕЛЬ ПИТАНИЯ ЕВРОПА	CABLE SECTEUR EUROPE CABLE ELECTRICO CE-GODKÄND ANSLUTNINGSKABEL	LEITUNG STROMVERSORGUNG CABO DE PODER	1	EUROPE PLUG	X		
10	EAX0039J00A	POWER SUPPLY CABLE CAVO DI ALIMENTAZIONE КАБЕЛЬ ПИТАНИЯ	CABLE SECTEUR CABLE ELÉCTRICO	NETZKABEL CABO DE ALIMENTAÇÃO	1	JAPAN PLUG	X		
11	8-23662A	LABEL TARGA CONNESSIONE DI RETE НАКЛЕЙКА	PLAQUE CONNEXION SECTEUR PLACA CONEXIÓN DE RED DEKAL	SCHILD NETZANSCHLUSS PLACA CONEXÃO DE REDE	1			X	
12	1-11103	SCREW VITE ВИНТ	VIS TORNILLO	SCHRAUBE PARAFUSO	2	M3X10 FLAT HEAD	X		
13	2-68948A	FILTERED POWER ENTRY MODULE MODULO DI INGRESSO CON FILTRO МОДУЛЬ ПОДАЧИ ПИТАНИЯ С ФИЛЬТРОМ	MODULE D'ENTRÉE SECTEUR MÓDULO DE LA ENTRADA DE LA ENERGÍA ANSLUTNINGSMODUL	GERÄTESTECKER-KOMBI-MODUL MÓDULO DA ENTRADA DO PODER	1		X		X
14	EAW0277G08A	BALANCING MACHINE WIRING HARNESS CABLAGGIO EQUILIBRATRICE ПУЧОК ПРОВОДОВ БАЛАНСИР. СТЕНДА	CABLAGE EQUILIBREUSE CABLEADO EQUILIBRADORA	VERKABELUNG AUSWUCHTMASCHINE CABAGEM EQUILIBRADORA	1		X		
14	EAW0286G47A	BALANCING MACHINE AND LASER POINTER CABLAGGIO EQUILIBRATRICE E LASER POIN ПУЧОК ПРОВОДОВ БАЛАНСИР. СТЕНДА	CABLAGE EQUILIBREUSE CABLEADO EQUILIBRADORA	VERKABELUNG AUSWUCHTMASCHINE CABAGEM EQUILIBRADORA	1	Laser Pointer	X		
15	2-13258A	MAIN SWITCH INTERRUPTORE GENERALE ВЫКЛЮЧАТЕЛЬ	COMMUTATEUR INTERRUPTOR HUVUDSTRÖMBRYTARE	SCHALTER INTERRUPTOR	1		X		

A available - disponible - vorhanden - beschikbaar - tillgänglig
disponibile - disponible - disponivel - Доступно

B on request - sur demande - auf Antrag - op aanvraag - på begäran
a richiesta - a petición - no pedido - По запросу

C suggested - suggeré - vorgeschlagene - aanbevolen - föreslog
consigliato - sugerido - sugerido - Предлагается

EAZ0088G16A

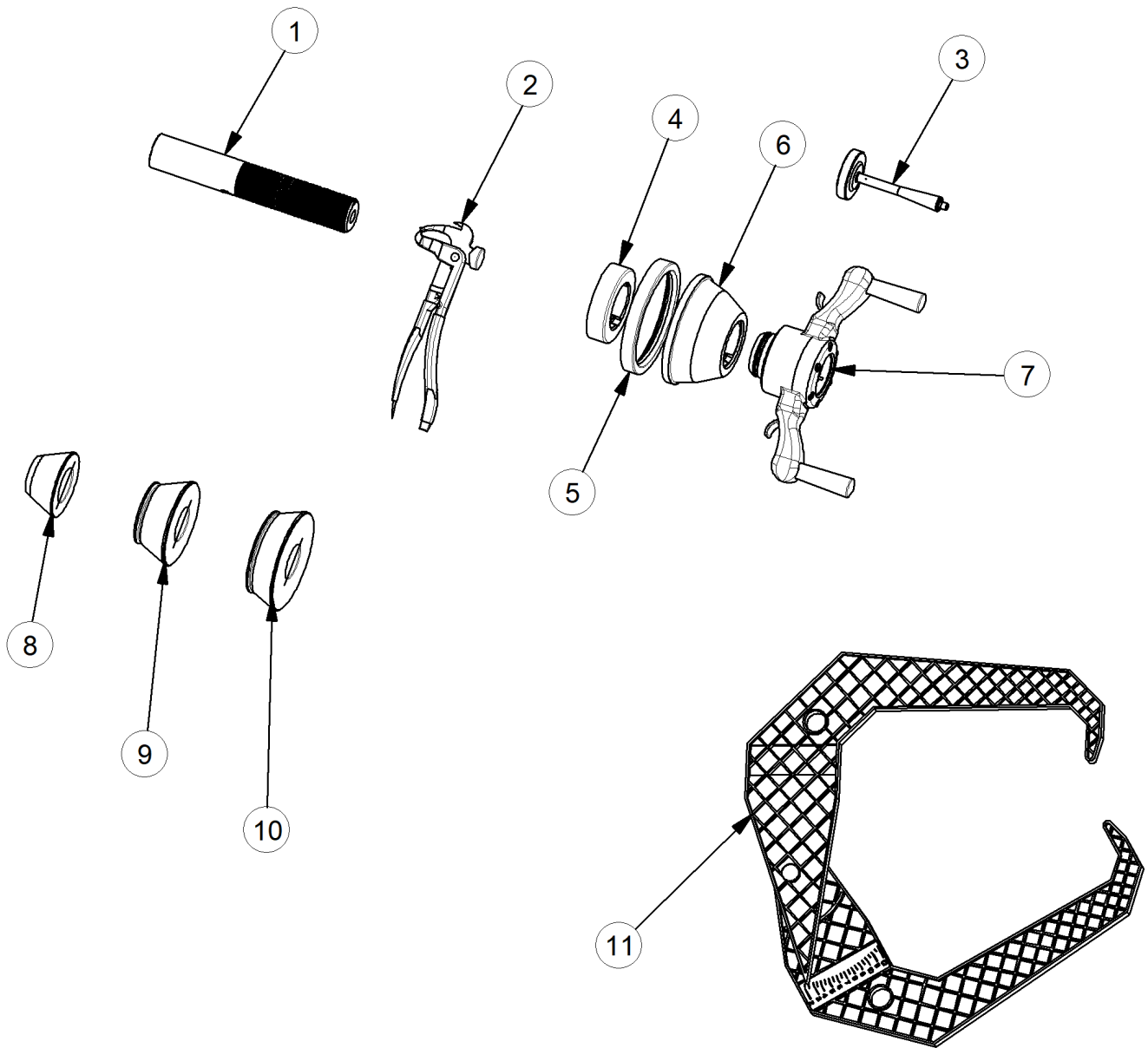

04/2014

Pos	Code	Designation Designazione ОПИСАНИЕ	Désignation Designación Benämning	Bezeichnung Designação	N.	Note Nota HOTa	A	B	C
1	EAM0021D90A	THREADED SHAFT TR40x4 ALBERO FILETTATO40x4 РЕЗЬБОВОЙ ВАЛ TR40X4	ARBRE FILETE 40x4 ÁRBOL ROSCADO 40X4	GEWINDEWELLE40x4 EIXO ROSQUEADO40x4	1		X		
2	8-04250A	PLIERS, WHEEL WEIGHTS PINZE PER CONTRAPPESI КЛЕЩИ БАЛАНСИРОВОЧНЫЕ	PINCE POUR MASSES ALICATES PARA PESOS	GEWICHTZANG PINÇAS PARA CONTRAPESOS	1		X		
3	EAM0005D40A	CALIBRATION WEIGHT PESO DI CALIBRAZIONE КАЛИБРОВОЧНЫЙ ГРУЗ	MASSE D'ÉTALONNAGE PESO DE CALIBRACIÓN	JUSTIERGEWICHT PESO DA CALIBRAÇÃO	1		X		
3	EAM0005D40A	CALIBRATION WEIGHT 2 BRACCIO CALIBRO TARATURA HWT КАЛИБРОВОЧНЫЙ ГРУЗ	BRAS ETALON REGLAGE HWT BRAZO CALIBRE CALIBRADO HWT	ABTASTARM EICHUNG HWT BRAÇO CALIBRE CALIBRAÇÃO HWT	1		X		
3	EAM0005D40A	CALIBRATION WEIGHT 2 BRACCIO CALIBRO TARATURA HWT КАЛИБРОВОЧНЫЙ ГРУЗ	BRAS ETALON REGLAGE HWT BRAZO CALIBRE CALIBRADO HWT	ABTASTARM EICHUNG HWT BRAÇO CALIBRE CALIBRAÇÃO HWT	1		X		
4	EAC0058D08A	Pressure ring Anello di spinta Упорное кольцо	Bague de serrage Anillo de empuje	Druckring Anel da impulso	1		X		
5	EAC0058D15A	Protective ring Anello protettivo Защитное кольцо	Bague de protection Anillo protector	Schutzring Anel protetor	1		X		
5	EAC0058D15A	RUBBER PROTECTION RING PROTEZIONE PER FLANGIA CONICA ЗАЩИТНОЕ КОЛЬЦО	PROTECTION POUR FLASQUE CONIQUE PROTECCIÓN PARA BRIDA CÓNICA	GUMMISCHUTZ FÜR KEGELRING PROTECÇÃO PARA FLANGE CÓNICO	1			X	
6	EAC0058D07A	Clamping head Tazza premiruota ПРИЖИМНАЯ ЧАШКА	Tête de serrage Caja de presión	Andrückhaube Copa prensa-roda	1		X		
7	EAA0263G66A	QUICKNUT, DIAMETER 40MM GHIERA RAPIDA D.40 БЫСТРОЗАЖИМНАЯ ГАЙКА 40MM	BAGUE RAPIDE D.40 ABRAZADERA RÁPIDA D. 40	SCHNELLSPANNMUTTER D.40 ARO RÁPIDO D.40	1		X		
8	EAM0005D23A	Cone Cono Конус	Cône Cono	Konus Cone	1	N.1 "ECON" D40	X		
9	EAM0005D24A	Cone Cono Конус	Cône Cono	Konus Cone	1	D.48 - 80 mm N.2 "ECON" D40	X		
10	EAM0005D25A	Cone Cono Конус	Cône Cono	Konus Cone	1	D.73 - 94 mm N.4 "ECON" D40	X		
11	EAA0247G21A	CALIPER RIM WIDTH GRUPPO CALIBRO LARGHEZ. RUOTE ИЗМЕРИТЕЛЬ ШИРИНЫ ДИСКА	GROUPE ETALON LARGEUR ROUES GRUPO CALIBRE ANCHO RUEDAS	MESSARM-GRUPPE FELGEN-BREITE CONJUNTO CALIBRADOR LARGURA RODAS	1	D.94 - 115 mm B100, Geo 7100	X		

EAZ0070G83A

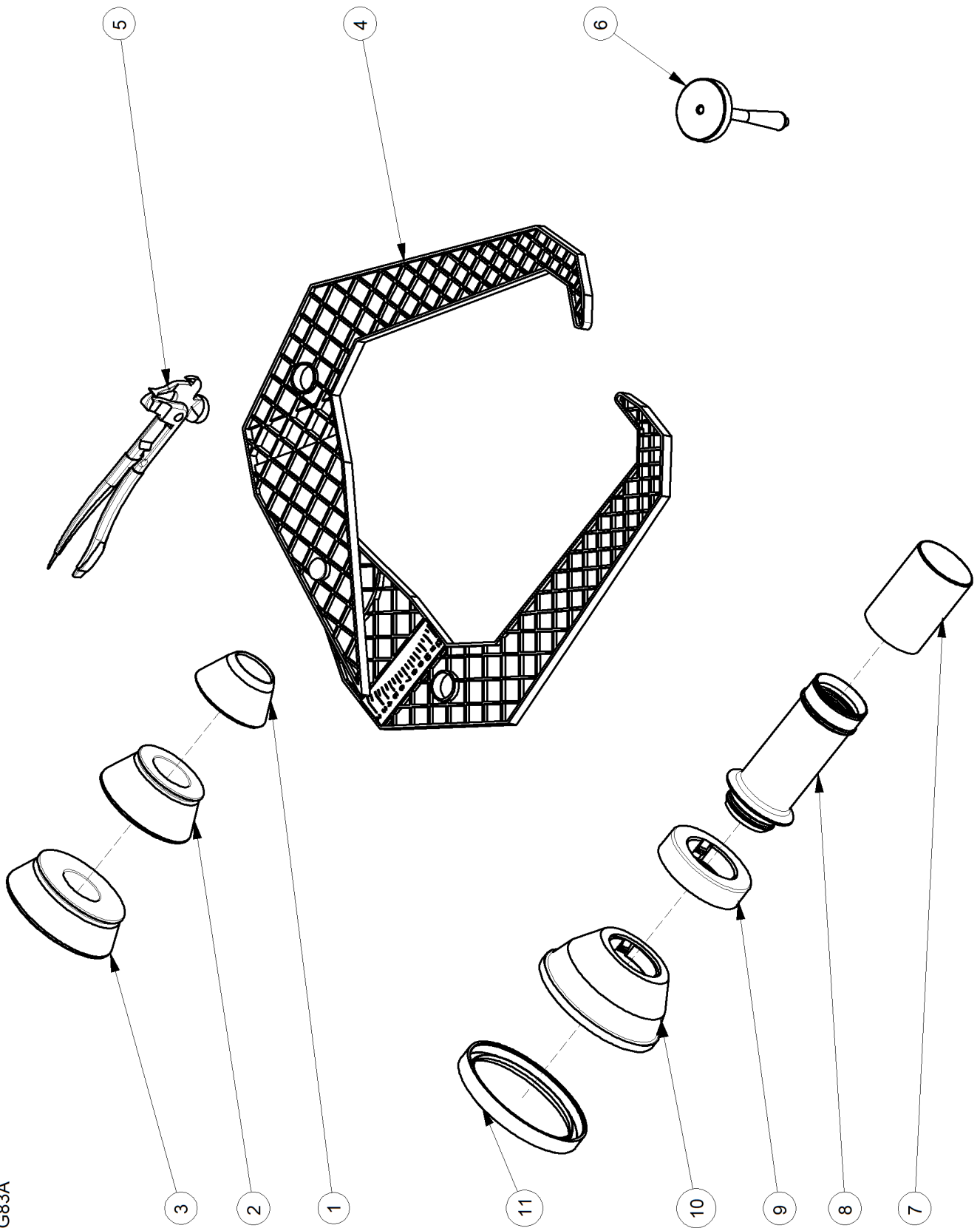

02/2014

Pos	Code	Designation Designazione ОПИСАНИЕ	Désignation Designación Benämning	Bezeichnung Designação	N.	Note Nota HOTa	A	B	C
1	EAM0005D23A	Cone Cono Конус	Cône Cono	Konus Cone	1	N.1 "ECON" D40 D.48 - 80 mm	X		
2	EAM0005D24A	Cone Cono Конус	Cône Cono	Konus Cone	1	N.2 "ECON" D40 D.73 - 94 mm	X		
3	EAM0005D25A	Cone Cono Конус	Cône Cono	Konus Cone	1	N.4 "ECON" D40 D.94 - 115 mm	X		
4	EAA0247G21A	CALIPER RIM WIDTH GRUPPO CALIBRO LARGHEZ. RUOTE ИЗМЕРИТЕЛЬ ШИРИНЫ ДИСКА	GROUPE ETALON LARGEUR ROUES GRUPO CALIBRE ANCHO RUEDAS	MESSARM-GRUPPE FELGEN-BREITE CONJUNTO CALIBRADOR LARGURA RODAS	1	B100, Geo 7100	X		
5	8-04250A	PLIERS, WHEEL WEIGHTS PINZE PER CONTRAPPESI КЛЕЩИ БАЛАНСИРОВОЧНЫЕ	PINCE POUR MASSES ALICATES PARA PESOS	GEWICHTZANG PINÇAS PARA CONTRAPESOS	1		X		
6	EAM0005D40A	CALIBRATION WEIGHT PESO DI CALIBRAZIONE КАЛИБРОВОЧНЫЙ ГРУЗ	MASSE D'ÉTALONNAGE PESO DE CALIBRACIÓN	JUSTIERGEWICHT PESO DA CALIBRAÇÃO	1		X		
7	EAC0058D69A	Protective sleeve Manicotto di protezione Предохранительная втулка	Douille de protection Manguito de protección	Schutzhülse JUNTURA DE PROTECAO	1		X		
8	EAM0086G86A	Clamping sleeve Manicotto di bloccaggio Зажимная втулка	Douille de serrage Manguito de bloqueo	Spannhülse Juntor de bloqueio	1		X	X	
9	EAC0058D08A	Pressure ring Anello di spinta Упорное кольцо	Bague de serrage Anillo de empuje	Druckring Anel da impulso	1		X		
10	EAC0058D07A	Clamping head Tazza premiruota ПРИЖИМНАЯ ЧАШКА	Tête de serrage Caja de presión	Andrückhaube Copa prensa-roda	1		X		
11	EAC0058D15A	Protective ring Anello protettivo Защитное кольцо	Bague de protection Anillo protector	Schutzring Anel protetor	1		X		

A available - disponible - vorhanden - beschikbaar - tillgänglig
disponibile - disponible - disponivel - Доступно

B on request - sur demande - auf Antrag - op aanvraag - på begäran
a richiesta - a petición - no pedido - По запросу

C suggested - suggeré - vorgeschlagene - aanbevolen - föreslog
consigliato - sugerido - sugerido - Предлагается

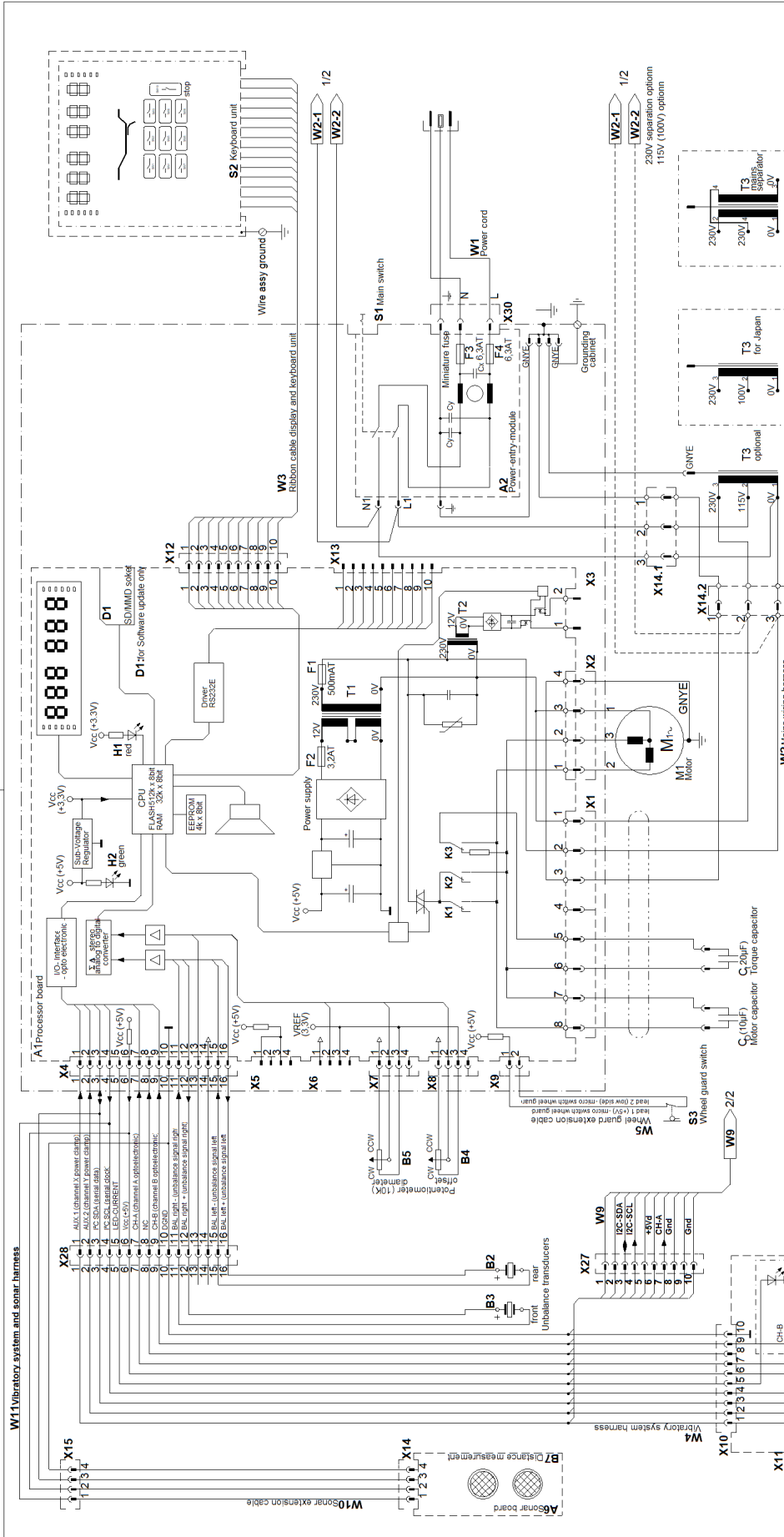

DENOMINAZIONE: SCHEMA ELETTRICO		FAMIGLIA: 824		COD. GS: EEWB559AWD	
THE DATA, DRAWINGS, AND INFORMATION CONTAINED IN THIS DOCUMENT IS CONFIDENTIAL AND THE SOLE PROPERTY OF SNAP-ON, AND MAY NOT BE REPRODUCED, USED, OR DISCLOSED WITHOUT WRITTEN PERMISSION OF AN OFFICER OF SNAP-ON.					
UNLESS OTHERWISE SPECIFIED DIMENSIONS ARE IN MILLIMETERS MATERIAL GENERAL TOLERANCES:					
OVER 0.5 TO 6.0 ± 0.1					
OVER 6.0 TO 30 ± 0.2					
OVER 30 TO 120 ± 0.3					
OVER 120 TO UP ± 0.5					
ANGULAR ± 1°					
HOLES ± 0.1					
SHEET METAL ± 0.5					
SURFACE: ISO 1302					
C 14G025C		A3 APP		RELEASE REVC	
B 14G0212		QUALITY DOC N/A		EEWB559AWD	
A 13G0348		SUPERCEDES N/A		SHEET 1 OF 2	

REV	CHANGES - MODIFICHE	DATE	NAME
C	Fixed offset potentiometer	2014.10.22N.	Castagnoli
B	Added transformers mains connection for laser pointer	2014.07.28N.	Castagnoli
A	Production release	2013.10.07N.	Castagnoli



CORREGGIO, ITALY
PROJ NO300
DR N. Castagnoli 2013.10.07
CK

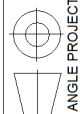

FIRST ANGLE PROJECTION

- | | | | |
|-----|---|-----|--|
| A1 | Controller board | K1 | Forward run relay |
| A2 | Entry module | K2 | Reverse run relay |
| A3 | Opto electronic board | K3 | Torque capacitor CT relay |
| A5 | A-weight board | M1 | Motor |
| A6 | Sonar board | M2 | Pointer stepper motor |
| A7 | Opto-switch board pointer home position | S1 | Main switch |
| B1 | Temperature sensor | S2 | Keyboard unit |
| B2 | Piezo rear | S3 | Wheel guard switch |
| B3 | Piezo front | T3 | Step-up transformer |
| B4 | Offset gauges, potentiometer (10K) with cable | W1 | Power cord |
| B5 | Diameter gauges, potentiometer (10K) with cable | W2 | Mains wiring harness |
| B7 | Distance measurement | W3 | Ribbon cable display and keyboard unit |
| B8 | Incremental encoder main shaft | W4 | Vibratory system harness |
| Co | Motor capacitor 10uF | W5 | Wheelguard extension wire |
| CT | Torque capacitor 20uF | W6 | Laser pointer extension cable |
| D1 | Software update socket | W7 | Opto-switch board pointer cable |
| F1 | Miniature fuse 500mA | W8 | Pointer stepper motor cable |
| F3 | Miniature fuse 6.3AT | W9 | Vibratory system harness extension |
| F4 | Miniature fuse 6.3AT | W10 | Sonar extension cable |
| H1 | Red LED | W11 | Vibratory system and sonar harness |
| H2 | Green LED | | |
| H11 | Pointer laser module | | |

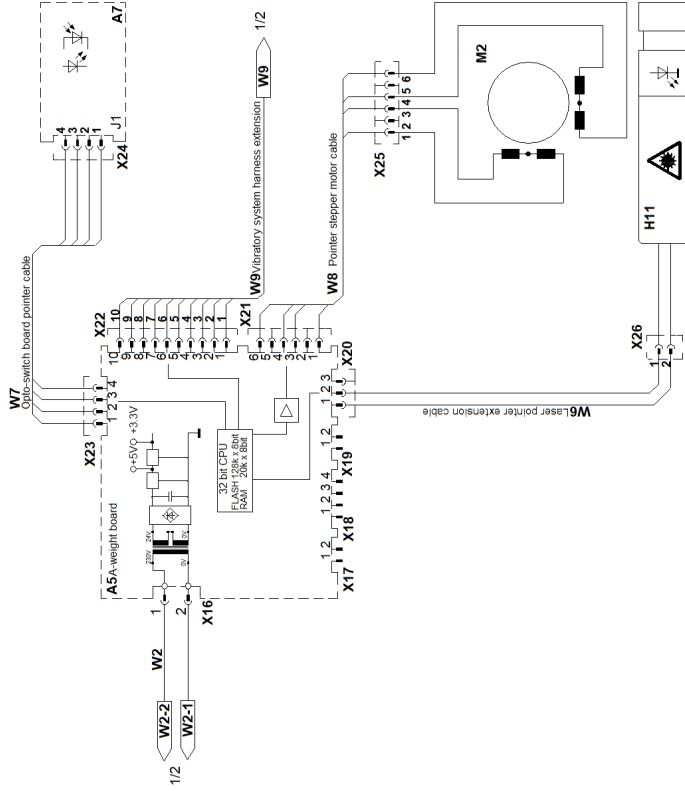

DENOMINAZIONE:	SCHEMA ELETTRICO	FAMIGLIA:	824	COD. GS:	EEWB559AWD
THE DATA, DRAWINGS, AND INFORMATION CONTAINED IN THIS DOCUMENT IS CONFIDENTIAL AND THE SOLE PROPERTY OF SNAP-ON, AND MAY NOT BE REPRODUCED, USED, OR DISCLOSED WITHOUT WRITTEN PERMISSION OF AN OFFICER OF SNAP-ON. COPYRIGHT 2013					
UNLESS OTHERWISE SPECIFIED DIMENSIONS ARE IN MILLIMETERS MATERIAL					
GENERAL TOLERANCES					
OVER 0.5 TO 6.0 ± 0.1					
OVER 6.0 TO 30 ± 0.2					
OVER 30 TO 120 ± 0.3					
OVER 120 TO UP ± 0.5					
ANGULAR ± 1°					
HOLES ± 0.1					
SHEET METAL ± 0.5					
SURFACE: ISO 1302					
A3		APP		RELEASE	REVC
FIRST ANGLE PROJECTION		QUALITY DOC		N/A	EEWB559AWD
		SUPERCEDES		N/A	SHEET 2 OF 2

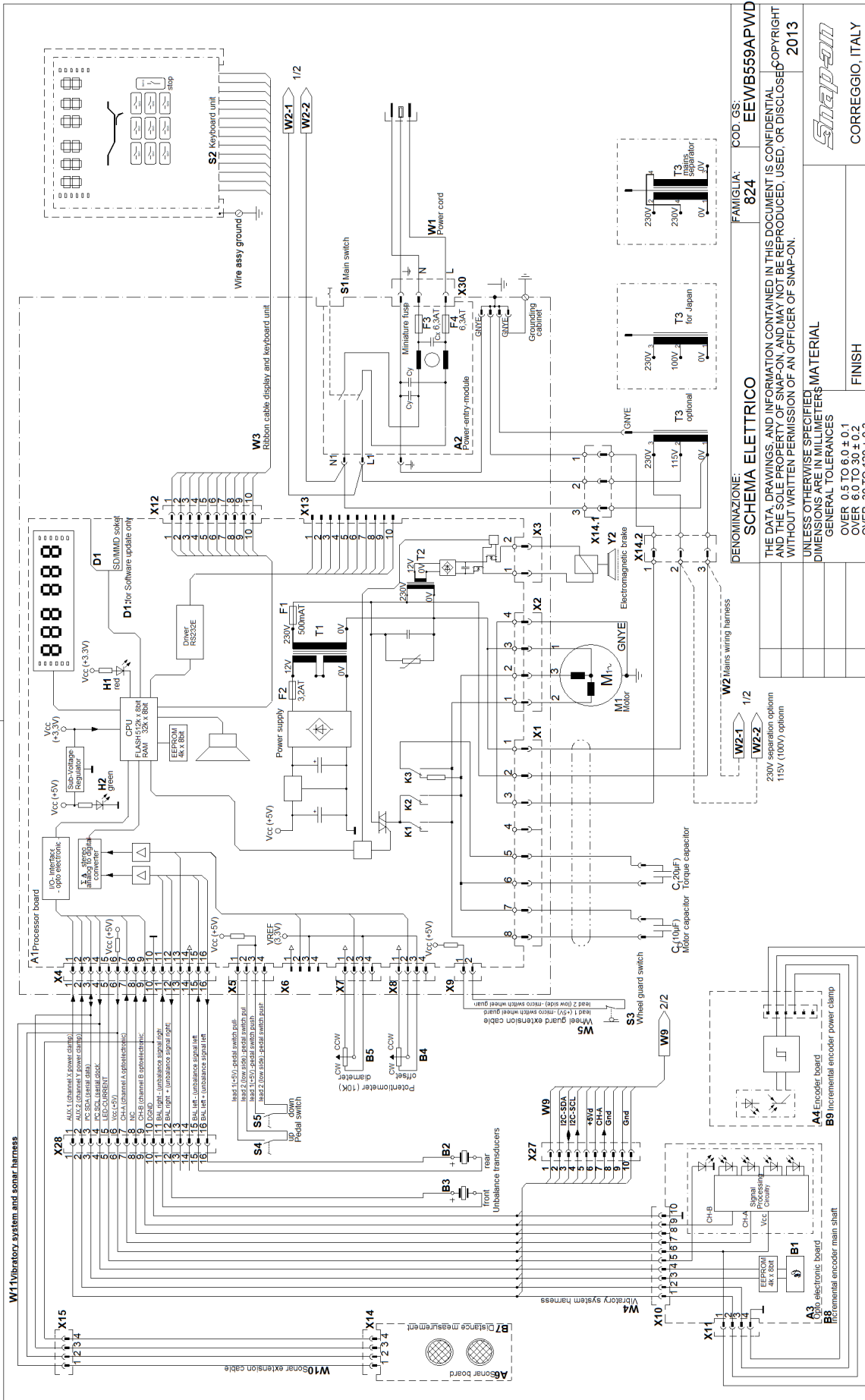

DENOMINAZIONE: SCHEMA ELETTRICO		FAMIGLIA: 824	COD. GS: EEWB559APWD
THE DATA, DRAWINGS, AND INFORMATION CONTAINED IN THIS DOCUMENT IS CONFIDENTIAL AND THE SOLE PROPERTY OF SNAP-ON, AND MAY NOT BE REPRODUCED, USED, OR DISCLOSED WITHOUT WRITTEN PERMISSION OF AN OFFICER OF SNAP-ON. © COPYRIGHT 2013			
UNLESS OTHERWISE SPECIFIED DIMENSIONS ARE IN MILLIMETERS MATERIAL GENERAL TOLERANCES			
OVER 0.5 TO 6.0 ± 0.1			
OVER 6.0 TO 30 ± 0.2			
OVER 30 TO 120 ± 0.3			
OVER 120 TO UP ± 0.5			
ANGULAR ± 1°			
HOLES ± 0.1			
SHEET METAL ± 0.5			
SURFACE: ISO 1302			
C	14G0250	A3	APP
B	14G0212	Q	QUALITY DOC N/A
A	13G0348	Q	SUPERCEDES N/A
REV/PCN HISTORY	FIRST ANGLE PROJECTION	RELEASE	REV/C
REV	DATE	NAME	

CHANGES - MODIFICHE	DATE	NAME
C Fixed offset potentiometer	2014.10.22 N.	Castagnoli
B Added transformers mains connection for laser pointer	2014.07.28 N.	Castagnoli
A Production release	2013.10.07 N.	Castagnoli

Snap-on
CORREGGIO, ITALY
WIRING DIAGRAM
DR. N. Castagnoli 2013.10.07
CK

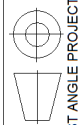

- A1 Controller board
- A2 Entry module
- A3 Opto electronic board
- A4 Encoder board
- A5 A-weight board
- A6 Sonar board
- A7 Opto-switch board pointer home position
- B1 Temperature sensor
- B2 Piezo rear
- B3 Piezo front
- B4 Offset gauges, potentiometer (10K) with cable
- B5 Diameter gauges, potentiometer (10K) with cable
- B7 Distance measurement
- B8 Incremental encoder main shaft
- B9 Incremental encoder power clamp
- Co Motor capacitor 10uF
- CT Torque capacitor 20uF
- D1 Software update socket
- F1 Miniature fuse 500mA
- F3 Miniature fuse 6.3AT
- F4 Miniature fuse 6.3AT
- H1 Red LED
- H2 Green LED
- H11 Pointer laser module
- K1 Forward run relay
- K2 Reverse run relay
- K3 Torque capacitor CT relay
- M1 Motor
- M2 Pointer stepper motor
- S1 Main switch
- S2 Keyboard unit
- S3 Wheel guard switch
- S4 Pedal switches
- S5 Pedal switches
- T3 Step-up transformer
- W1 Power cord
- W2 Mains wiring harness
- W3 Ribbon cable display and keyboard unit
- W4 Vibratory system harness
- W5 Wheelguard extension wire
- W6 Laser pointer extension cable
- W7 Opto-switch board pointer cable
- W8 Pointer stepper motor cable
- W9 Vibratory system harness extension
- W10 Sonar extension cable
- W11 Vibratory system and sonar harness
- Y2 Electromagnetic brake

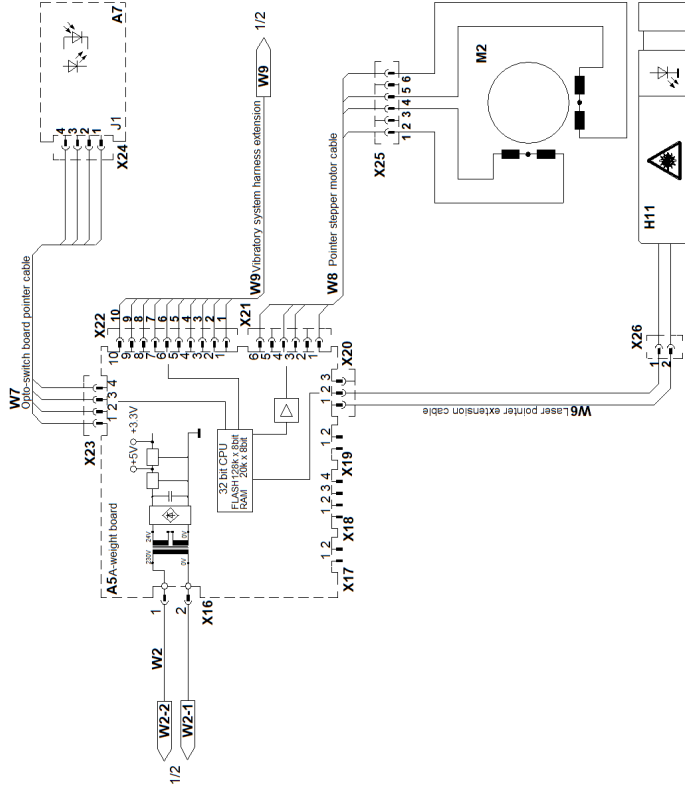

DENOMINAZIONE:	SCHEMA ELETTRICO	FAMIGLIA:	824	COD. GS:	EEWB559APWD
THE DATA, DRAWINGS, AND INFORMATION CONTAINED IN THIS DOCUMENT IS CONFIDENTIAL AND THE SOLE PROPERTY OF SNAP-ON, AND MAY NOT BE REPRODUCED, USED, OR DISCLOSED WITHOUT WRITTEN PERMISSION OF AN OFFICER OF SNAP-ON. COPYRIGHT 2013					
UNLESS OTHERWISE SPECIFIED DIMENSIONS ARE IN MILLIMETERS MATERIAL					
GENERAL TOLERANCES					
OVER 0.5 TO 6.0 ± 0.1					
OVER 6.0 TO 30 ± 0.2					
OVER 30 TO 120 ± 0.3					
OVER 120 TO UP ± 0.5					
ANGULAR ± 1°					
HOLES ± 0.1					
SHEET METAL ± 0.5					
SURFACE: ISO 1302					
A3 APP		CORREGGIO, ITALY		WIRING DIAGRAM	
QUALITY DOC N/A		DR N. Castagnoli		2013.10.07	
SUPERCEDES N/A		CK		RELEASE REV C	
FIRST ANGLE PROJECTION		EEWB559APWD		SHEET 2 OF 2	

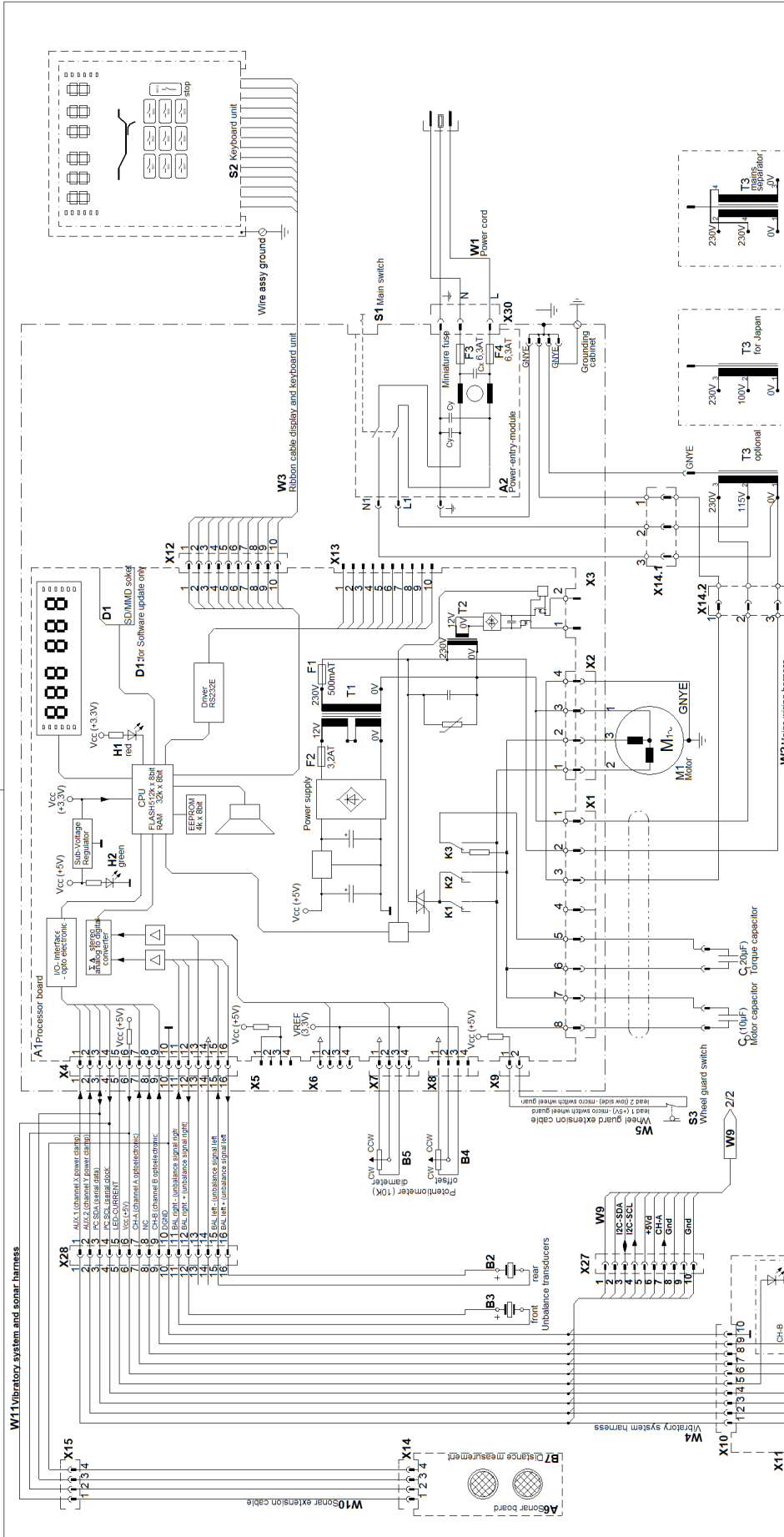

DENOMINAZIONE: SCHEMA ELETTRICO		COD. GS: EEWB573AWD	
FAMIGLIA: 824		COPYRIGHT 2014	
THE DATA, DRAWINGS, AND INFORMATION CONTAINED IN THIS DOCUMENT IS CONFIDENTIAL AND THE SOLE PROPERTY OF SNAP-ON, AND MAY NOT BE REPRODUCED, USED, OR DISCLOSED WITHOUT WRITTEN PERMISSION OF AN OFFICER OF SNAP-ON.			
MATERIAL		Snap-on	
FINISH		CORREGGIO, ITALY	
PROJ NO 300S		WIRING DIAGRAM	
DR N. Castagnoli		2014.10.22	
CK			
A3 APP		RELEASE REV A	
QUALITY DOC N/A		EEWB573AWD	
SUPERCEDES N/A		SHEET 1 OF 1	

REV	CHANGES - MODIFICHE	DATE	NAME
A	Production release	2014.10.22	N. Castagnoli

ENG - DECLARATION OF CE CONFORMITY
FRA - DECLARATION CE DE CONFORMITE
DEU - KONFORMITÄTSEKTLÄRUNG
FIN - EY-VAATIMUSTENMUKAISUUSVAKUUTUS
NLD - VERKLARING VAN OVEREENSTEMMING
SWE - EG-FÖRSÄKRAN OM ÖVERENSSTÄMMELSE
DAN - EF-OVERENSSTEMMELSESERKLÆRING
ISL - EB-SAMRÆMISYFIRLÝSING
POL - DEKLARACJA ZGODNOŚCI "CE"
RUM - DECLARAȚIE DE CONFORMITATE CU NORMELE CE
SLO - ES VYHLÁSENIE O ZHODE
SLV - IZJAVA O SKLADNOSTI CE
ALB - DEKLARATË KONFORMITETI KE
HUN - EK MEGFELELŐSÉGI NYILATKOZAT



DICHIARAZIONE CE DI CONFORMITA' - ITA
DECLARAÇÃO CE DE CONFORMIDADE - POR
DECLARACIÓN CE DE CONFORMIDAD - SPA
ДЕКЛАРАЦИЯ ЗА СЪОТВЕТСТВИЕ - BUL
ES PROHLÁŠENÍ O SHODĚ - CES
DEKLARACIJA CE O PODOBNOSTI - HRV
EÜ VASTAVUSDEKLARATSIOON - EST
ΔΗΛΩΣΗ CE ΣΥΜΜΟΡΦΩΣΗΣ - ELL
ES ATBILSTĪBAS DEKLARĀCIJA - LAV
ATITIKTIES DEKLARACIJA - LIT
"EC" ДЕКЛАРАЦИЈА ЗА СООБРАЗНОСТ - MKD
DEKLARACIJA CE O USKLAĐENOSTI - MON
EC UYGUNLUK BEYANNAMESİ - TUR
ДЕКЛАРАЦИЈА СООТВЕТСТВИЈА СТАНДАРТАМ ЕС - RUS

Snap-on Equipment Srl - Via Provinciale per Carpi, 33 - 42015 Correggio (RE) Italy

ENG - takes full responsibility for declaring that the machine:
FRA - déclare sous sa propre responsabilité que la machine :
DEU - erklärt auf eigene Verantwortung, dass die Maschine:
ITA - dichiara sotto la propria responsabilità che la macchina:
POR - declara sob a própria responsabilidade que a máquina:
SPA - declara bajo su propia responsabilidad que la máquina:
ALB - deklaron nën përgjegjësinë e tij se makineria:
BUL - декларира под отговорност, че машината:
CES - prohlašuje na vlastní zodpovědnost, že strojní zařízení:
HRV - izjavljuje pod vlastitom odgovornošću da stroj:
DAN - erklærer på eget ansvar, at maskinen:
EST - kinnitab omal vastutusel, et aparaat:
FIN - vakuuttaa omalla vastuullaan, että kone:
ELL - δηλώνει υπεύθυνα ότι η μηχανή:
ISL - lýsir því yfir á eigin ábyrgð að billinn:
LAV - apzinādamies savu atbildību apliecina, ka mašīna/iekārta:
LIT - prisiimdamą atsakomybę skelbia, kad mašina:
MKD - изјавува под своја одговорност дека машината:
MON - izjavljuje pod vlastitom odgovorošću da mašina:
NLD - verklaart voor eigen verantwoordelijkheid dat de machine:
POL - oświadcza na własną odpowiedzialność, że maszyna:
RUM - declară pe propria răspundere că mașina:
SLO - vyhlasuje na vlastnú zodpovednosť, že strojové zariadenie:
SLV - pod lastno odgovornostjo izjavljamo, da je stroj:
SWE - försäkrar under eget ansvar att maskinen:
TUR - kendi sorumluluğu altında makinenin aşağıda belirtilen yönetmeliklere uygun olduğunu beyan etmektedir:
HUN - a saját felelőssége tudatában kijelenti, hogy a gép:
RUS - с полной ответственностью заявляет что машина

WHEEL BALANCER
EQUILIBREUSE
RADAUSWUCHTGERÄT
EQUILIBRATRICE
MÁQUINA DE EQUILIBRAR RODAS
EQUILIBRADORA
EKUILIBRUESE
МАШИНА ЗА БАЛАНСИРАНЕ НА ГУМИ
VYVAŽOVAČKA
BALANSER
HJULAFBALANCERINGSMASKINE
TASAKAALUSTUSSEADE
TASAPAINOTUSKONE
ΕΙΣΟΡΡΟΠΗΤΗΣ
JAFNVÆGISSTILLINGARVÉL
BALANŞÇANA
BALANSVIMAS
ИЗЕДНАЧУВАЧ
BALANSERKA
BALANCEERMACHINE
WYWAŻARKA
ECHILIBROR
VYVAŽOVAČKA
STROJ ZA URAVNOTEŽEVANJE
BALANSMASKIN
DENGLEYİCİ
KERÉKKIEGYENSÚLYOZÓ
БАЛАНСИРОВОЧНИЙ СТЕНД

JohnBean™

ENG - complies with all the relevant regulations in the following directives:
FRA - est conforme à toutes les dispositions pertinentes des directives suivantes :
DEU - Allen zu folgenden Richtlinien gehörenden Bestimmungen entspricht:
ITA - è conforme a tutte le disposizioni pertinenti delle seguenti direttive:
POR - satisfaz todas as disposições relevantes das seguintes directivas:
SPA - es conforme con todas las disposiciones pertinentes a las siguientes directivas:
ALB - është konform me të gjitha dispozitat që kanë të bëjnë me direktivat e mëposhtme:
BUL - съответства на всички разпоредби, съдържащи се в следващите директиви:
CES - vyhovuje všem požadavkům, které se vztahují na následující směrnice:
HRV - udovoljava svim relevantnim odredbama slijedećih smjernica:
DAN - er i overensstemmelse med bestemmelserne i følgende direktiver:
EST - vastab järgmistele direktiivide kõikidele asjassepuutuvatele sätetele:
FIN - on seuraavien direktiivien asiaankuuluvien säännösten mukainen:
ELL - είναι σύμφωνα με όλες τις προβλέψεις σχετικές με τις ακόλουθες οδηγίες:
ISL - er í samræmi við allar viðeigandi tilskipanir eftirfarandi reglugerða:
LAV - atbilst visiem attiecigajiem noteikumiem šādās direktīvās:
LIT - atitinka visus toliau nurodytų direktyvų reikalavimus:
MKD - e во согласност со сите норми од следниве директиви:
MON - je u skladu sa svim relevantnim odredbama sledećih direktiva:
NLD - overeenstemt met alle toepasselijke voorschriften van de volgende richtlijnen:
POL - jest zgodna (jest zgodny) ze wszystkimi zarządzeniami zawartymi w następujących dyrektywach:
RUM - este fabricat în conformitate cu toate prevederile în materie din următoarele directive:
SLO - vyhovuje všetkým požiadavkám, vzťahujúcim sa na nasledujúce smernice:
SLV - v skladu z vsemi predpisi, ki se nanašajo na naslednje direktive:
SWE - överensstämmer med alla bestämmelser tillhörande följande direktiv:
TUR - aşağıda belirtilen yönetmeliklere ilişkin tüm hükümlere uygundur:
HUN - megfelel a következő irányelvekbe foglalt, valamennyi rendelkezésnek:
RUS - соответствует всем применяемым нормам следующих директив:

2006/42/EC

2014/30/EU

ENG-The Manager of the Technical Office is authorised to compile a technical leaflet in compliance with appendix VII, letter A, of the 2006/42/CE directive.
FRA-Le Responsable du Bureau Technique est autorisé à constituer le fascicule technique visé sous l'annexe VII lettre A de la directive 2006/42/CE.
DEU-Der Leiter der technischen Abteilung ist bevollmächtigt, die technischen Unterlagen zu erstellen (siehe Anhang VII, Buchstabe A der Richtlinie 2006/42/CE).
ITA-Il Responsabile dell'Ufficio Tecnico è autorizzato a costituire il fascicolo tecnico di cui all'allegato VII lettera A della direttiva 2006/42/CE.
POR-O Responsável do Gabinete Técnico está autorizado a compilar o processo técnico, referido no anexo VII alínea A da directiva 2006/42/CE.
SPA-El Responsable del Departamento Técnico está autorizado a constituir el fascículo técnico indicado en el anexo VII letra A de la directiva 2006/42/CE.
ALB-Përgjegjësi i Zyrës Teknike është i autorizuar të realizojë fashikullin teknik sipas dokumentit bashkëngjitur VII germa A e direktivës 2006/42/KE.
BUL-Отговорникът на Техническият отдел е упълномощен да състави техническата брошура в съответствие с Приложение VII, „А“, Директива 2006/42/ЕС.
CES-Zodpovědný pracovník technického oddělení je oprávněný vypracovat technickou dokumentaci podle přílohy VII části A Směrnice 2006/42/ES.
HRV-Odgovorna osoba Tehničkog ureda je ovlaštena ustrojiti tehnički svezak kako se vidi u dodatku VII slovo A smjernice 2006/42/CE.
DAN-Chefen i den tekniske afdeling har tilladelse til udarbejdelse af den tekniske dokumentation jf. bilag VII litra A i direktivet 2006/42/EF.
EST-Tehnoosakonna vastutav töötaja on volitatud koostama tehnilise toimiku vastavalt direktiivi 2006/42/EÜ VII lisa osale A.
FIN-Teknisen toimiston vastuhenkilö on valtuutettu kokoamaan tekninen eritelmä direktiivin 2006/42/EY liitteen VII kohdan A mukaisesti.
ELL-ΟΥπεύθυνος του Τεχνικού Γραφείου είναι εξουσιοδοτημένος να παράξει τον τεχνικό φάκελο σύμφωνα με το συνημμένο VII γράμμα Α της οδηγίας 2006/42/ΕΚ.
ISL-Ábyrgðarmanni tækniskrifstofunnar er heimilt að gera tækniskjalið samkvæmt A-lið VII. viðauka í reglugerð 2006/42/EB.
LAV-Tehniskās nodaļas vadītājs ir pilnvarots sastādīt tehnisko dokumentāciju atbilstoši ES direktīvas 2006/42/EK VII pielikuma A iedaļai.
LIT-už techninį skyrių atsakingas asmuo yra įgaliotas sudaryti techninę bylą, kurios sudarymo tvarka nurodyta Direktyvos 2006/42/EB VII priedo A dalyje.
MKD-Odgovorniот на техничкиот оддел е овластен да го состави техничкиот прирачник даден во прилог VII писмо А од директивата 2006/42/CE.
MON-Odgovorno lice Tehničkog ureda je ovlašteno da sastavi tehničku fasciklu kako se vidi u dodatku VII slovo A direktive 2006/42/CE.
NLD-Het Hoofd van de Technische Afdeling is gemachtigd om het technisch dossier samen te stellen waarover in Bijlage VII, afdeling A, van de richtlijn 2006/42/EG.
POL-Kierownik Biura Projektowego jest upoważniony do założenia skroszytu technicznego, o którym mowa w Załączniku VII litera A dyrektywy 2006/42/UE.
RUM-Responsabilul Biroului Tehnice este autorizat să întocmească dosarul tehnic prevăzut în anexa VII litera A directiva 2006/42/CE privind echipamentele tehnice.
SLO-Zodpovedný pracovník technického oddelenia je oprávněný vypracovať technickú dokumentáciu podľa prílohy VII časti A Smernice 2006/42/ES.
SLV-Vodja tehničnega urada je pooblaščen za sestavo tehnične mape, kot navedeno v prilogi VII, črka A direktive 2006/42/ES.
SWE-Ansvarig på det tekniska kontoret har behörighet att sammanställa medföljande teknisk dokumentation i enlighet med avsnitt A i bilaga VII i direktiv 2006/42/EG.
TUR-Teknik Ofis Sorumlusu 2006/42/EC Yönetmeliği'nin VII. ekinin A harfinde belirtilen teknik dosyayı hazırlamaya yetkilidir.
HUN-AMűszaki Iroda Irodavezetője feljogosított a 2006/42/EK irányelv Arészének VII. Mellékletében meghatározott, műszaki dokumentáció összeállítására
RUS-Руководитель технического отдела уполномочен составить технический лист в соответствии с приложением VII, литер А директивы 2006/42/CE

ITA-Direttore Operativo SPA-Director Operativo POR-Director Operacional ENG-Operations Manager FRA-Directeur Opérationnel
DEU-Betriebsleiter ALB-Drejtori Operativ BUL-Оперативен директор CES-Výkonný ředitel HRV-Operativni direktor DAN-Driftsleder
EST-Tegevdirektor FIN-Operatiivinen johtaja ELL-Επιχειρησιακός Διευθυντής ISL-Starfandi framkvæmdarstjóri LAV-Operatīvais direktors
LIT-Operacijų vadovas MKD-Оперативен директор MON-Operativni direktor NLD-Operationeel directeur POL-Dyrektor Operacyjny
RUM-Director Operator SLO-Výkonný riaditeľ SLV-Operativni vodja SWE-Driftledare TUR-İşletme Müdürü HUN-Operatív Igazgató
RUS - Управляющий производством

Francesco Frezza

F. Frezza

CE

Correggio (RE) - ITALY

date:

JohnBean™

Technical modifications reserved.

Manufacturing Facility

Snap-on Equipment S.r.L.

Via Provinciale per Carpi 33,
42015 Correggio (R.E.), Italy

Tel. ++39 (0)522 733480

Fax: ++39 (0)522 733479

Notice: The information contained in this document is subject to change without notice. **John Bean** makes no warranty with regard to this material. **John Bean** shall not be liable for errors contained herein or for incidental consequential damages in connection with furnishings, performance, or use of this material.

This document contains proprietary information which is protected by copyright and patents. All rights are reserved. No part of this document may be photocopied, reproduced, or translated without prior written consent of **John Bean**.

John Bean is a registered trademark.

copyright 2020

SOE Digital Code SP_JB B300_20-10_AG_TEEWB573A3