

geodyna 2800

Operation manual
Form ZEEWB704D

Car wheel balancer

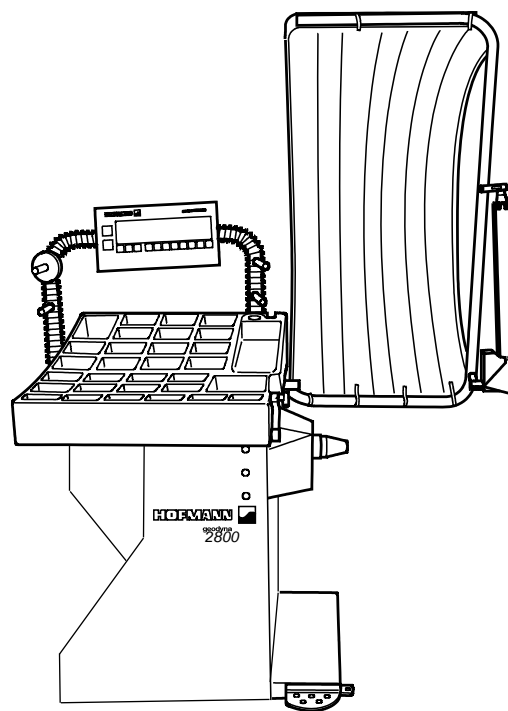

HOFMANN®





Contents	Page
1. Safety rules and function	2
2. Installation of the machine	5
3. Electrical connection	6
4. Controls and displays	7
5. Turning on the machine	13
6. Clamping the wheel	15
7. Entry of balancing mode and wheel size	17
8. Balancing the wheel	27
9. Hidden spoke placement	31
10. Changing modes of operation	33
11. Error codes	40
12. Pro-Match / weight minimisation	46
13. User calibration	57
14. Maintenance	58
15. Technical data	58
16. Electrical diagram	59

1. Safety rules and function

1.1 Special hints for the reader

A few special features were used in this manual to facilitate reading and understanding of pictures and written instructions:

- signals the operator where to act. Safety

rules are highlighted in grey.



Arrow showing where to look



Arrow showing the direction to move

1.2 Scope of application

The off-the-vehicle wheel balancer is designed for static and/or dynamic balancing of car and light-truck wheels weighing up to 150 lbs and having an overall diameter of 44".

In addition to conventional balancing operations, irregular running conditions of the wheel caused by geometric deformations of the rims and/or tires, hence unsmooth ride, can be identified, improved or, if possible, even eliminated. By exact adjustment of the two wheel components relative to each other optimum wheel running conditions or at least balance weight minimisation can be achieved.

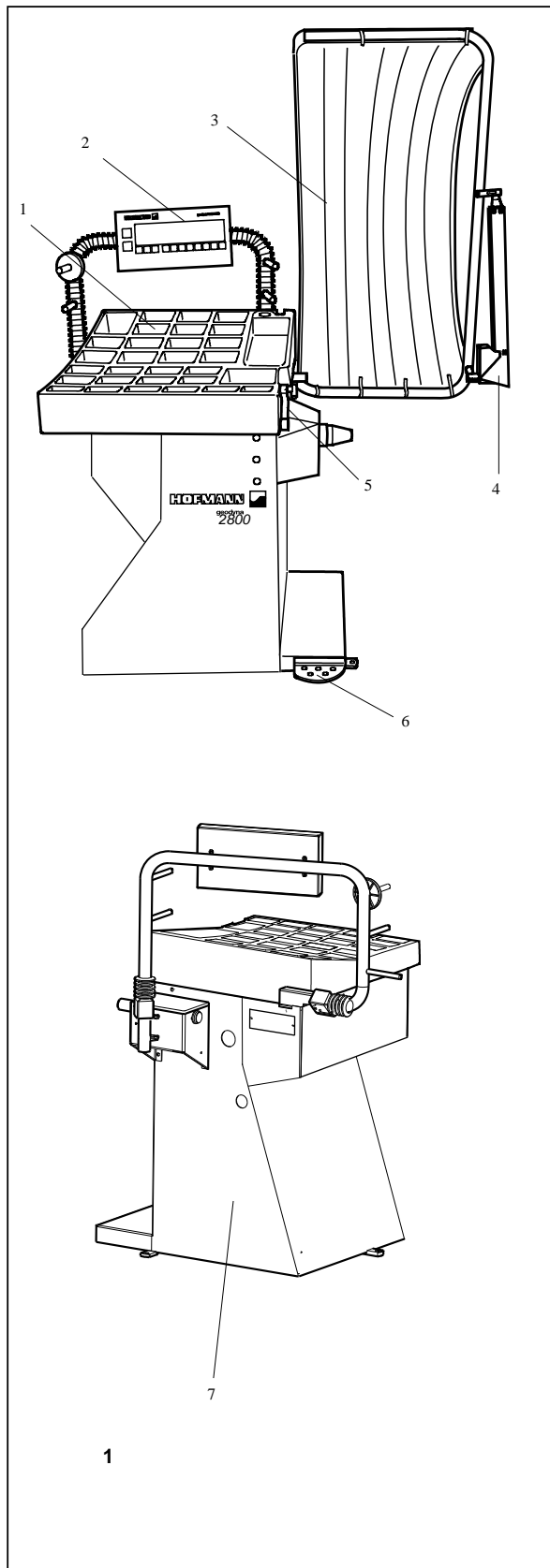

Fig. 1 View wheel balancer

- 1 Weight tray
- 2 Display and key pad
- 3 Wheel guard
- 4 Gauge arm for distance rim/machine and rim diameter
- 5 Width gauge arm
- 6 Pedal for main shaft lock
- 7 Rear view

1.3 General safety rules

Only properly trained and authorised personnel shall be allowed to operate the wheel balancer.

The machine must not be used except for the scope of application and in the way specified in this manual.

Unauthorised changes and modifications to the machine relieve the manufacturer from any liability for damages and injuries that might result therefrom.

On no account should safety features be removed or made inoperative.

In general any work on the electrical system such as fitting of a plug or changing of connections, if necessary, must be carried out by a qualified electrician in line with relevant national standards and the regulations of the local power station.

It should be noted that working with technical equipment may involve an unforeseeable acceptable risk.

Therefore the operator should eliminate such dangers in advance by proper and wise behaviour.

The following special points should be observed:

Use technical equipment for its specified scope of application only.

Always use suitable and proper equipment and tools.

Follow the instructions, notes and technical data of the machine manufacturer or manufacturer of the wheels to be balanced.

Wear suitable protective clothing and accessories (e. g. goggles, safety shoes, helmet).

For further safety rules to be observed, please refer to the individual chapters.



1.4 Description of function

Display and key pad

The display and key pad are arranged on the ergonomic front panel.

Gauge arm for distance and rim diameter

Entry of rim diameter and distance between left correction plane and machine is by means of an integrated gauge arm or also via the key pad. In the latter case the relative function key is held pressed while the wheel is rotated to choose the desired inputs and enter them by releasing the function key.

When fitting adhesive weights with the weight holder, the machine will support the operator in relocating the correction position.

Width gauge arm

The wheel balancer is equipped with a width gauge arm for automatic input of the rim width. Rim width can also be entered via the menu key and rotation of the wheel. **Balancing mode**

Readings in different balancing modes (weight position on the rim) can be given on the display, depending on the type of wheel to be balanced (car, light-truck, motorcycle, PAX, steel or alloy rim).

Measuring run and measured values

All measurements are taken and stored in one run during the automatic program. On completion of measurement the machine stops automatically and the wheel is slowed down to standstill. Amounts and locations of unbalance are read out separately for each correction plane. **Main shaft lock**

The machines have a pedal-operated main shaft lock which

is used to retain the wheel in the correction position so that the balance weights can be fitted. This lock is designed only to facilitate orientation of the wheel and must not be used for braking the main shaft. **Store wheel profiles**

Wheel profiles permit the storage of values for wheels that are balanced frequently in order to save having to enter the

wheel data etc. each time. It is possible to store up to 4 wheel profiles.

Error codes

Errors in operation or failures in the electronic or mechanical system are signalled via respective error codes (see § 11. Error codes).

User calibration

If several measuring runs are necessary to balance a wheel because balance weight size and position have to be adjusted repeatedly, this is often due to insufficient measurement accuracy. In such case the operator has the possibility of readjusting the machine (see § 13. User calibration). **Wheel guard**
A wheel guard with electric interlocking is mandatory for the

European Union and is part of the standard equipment. The measuring run may only be started with closed guard. The electronic unit can be programmed via code C13 so that measurement is started by closing of the guard.

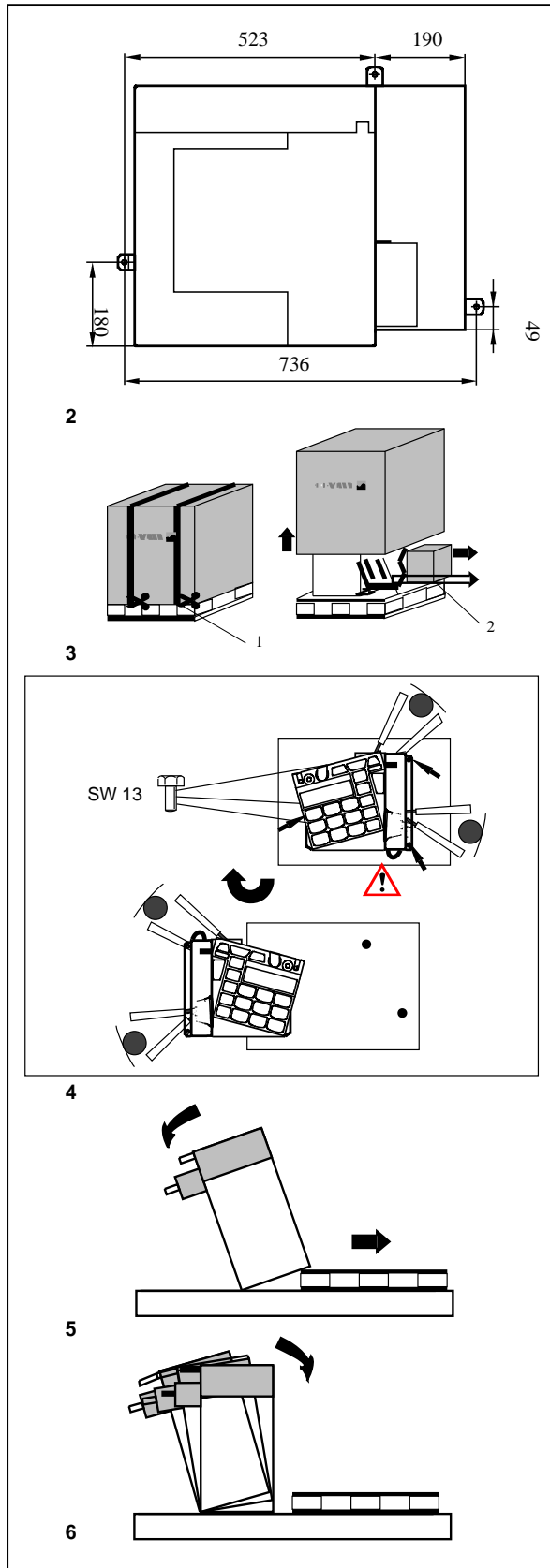

2. Installation of the machine

When choosing the site, Health and Safety at Work regulations and the regulations on working environment should be taken into account.

The wheel balancer can be installed on any firm and level ground. For the weight and space requirement of the machines refer to § 15., Technical data. For installation on an upper floor, observe permissible load capacity of the floor.

It is recommended, though not absolutely necessary, that the machine be secured to the floor. For this purpose three holes (Fig. 2) are provided in the base of the machine by which the latter is fixed on the floor with 3/8" anchor bolts. Fig. 2 shows the center-to-center distance of the holes. Make sure that the machine has a stable position, i.e. that it is supported on **three** seatings. If not, ensure three-point contact on ground by inserting appropriate spacers between the floor and machine base.

For ease of transport the wheel balancer is disassembled into the following units and provided with special packing (on pallets):

- Machine
- Wheel guard
- Width gauge arm

2.1 Unpacking the machine

The machine should be unpacked by two persons.

Note

When unpacking the machine make sure that the pedal fitted on the machine base and the whole pedal assembly is not damaged.

- Cut the strips of the packing (Fig. 3, item 1), lift off the packing, and set aside the wheel guard, the width gauge arm and the small parts packed in the separate small box (Fig. 3, item 2).
- Unscrew the three hexagon screws (use a 1/2" wrench to) which hold the machine on the pallet (Fig. 4, arrow).
- Lift the machine by tube of the vibratory system and wheel guard arbor and turn around by 180 degrees on the pallet (Fig. 4).
- Then lower one side of the machine laterally on the floor (Fig. 5).
- Remove the pallet from underneath the machine and gently lower the entire machine onto the floor (Fig. 6).

2.2 Resiting the machine

If the machine is transported on site, gently tilt it, taking it by weight box and wheel guard arbor, and push it gently on suitable lifting or mobile industrial handling equipment (e. g. forklift truck, platform truck).

Note

When lifting the machine bear in mind the centre of gravity of the machine and avoid oscillating movements.

Installation of the machine

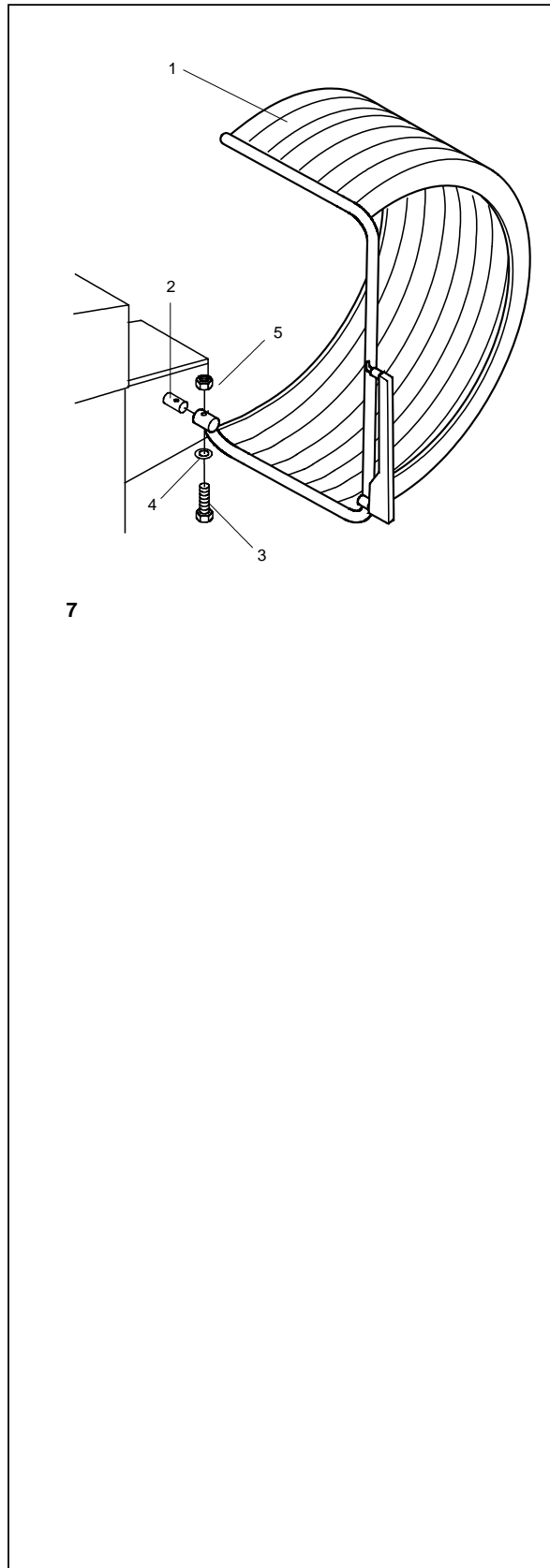

2.3 Mounting the wheel guard (Fig. 7)

- Slide the wheel guard (**Fig. 7, item 1**) on the arbor (**Fig. 7, item 2**) and raise it until the fastening holes of wheel guard and wheel guard arbor coincide.
- Insert the M10 setscrew (**Fig. 7, item 3**) with washer (**Fig. 7, item 4**) from below, and tighten the hexagon nut (**Fig. 7, item 5**) and washer.

The wheel guard influences the following modes of operation:

- The measuring run is started by closing the wheel guard (code C13).
- The wheel is braked on lifting the wheel guard during a measuring run (code C5).

These modes of operation can be changed either permanently, or only as long as the machine is switched on, by means of codes (see § 10. Changing modes of operation).

3. Electrical connection

In general any work on the electrical system such as fitting of a plug or changing of connections, if necessary, must be carried out by a qualified electrician in line with relevant national standards and the regulations of the local power station.

Electrical standard equipment and drive motor of the wheel balancer are provided for operation on 50/60 Hz, 115-120 V.

The connecting cable of the machine is designed as a separate power cord. For connection to the power mains the cable is provided with a NEMA 5-15P (U.S.) or C22.2 No. 42 (Canada) plug.

Fusing is by the customer before the plug connector, using a 15 amp circuit breaker.

The electrical diagram is illustrated in § 16.

The machine operates internally on a line voltage of 230 V because the voltage is regulated by an integrated transformer.

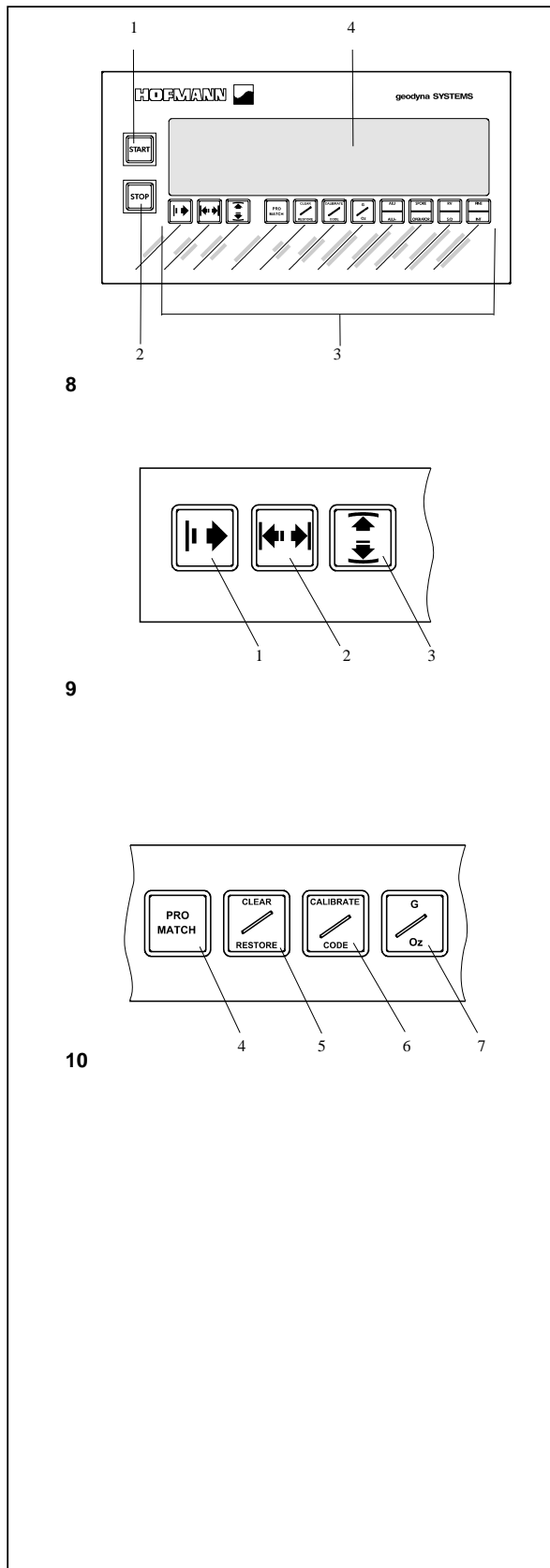

4. Controls and displays

Fig. 8 Overview

1 START key Start a

measuring run

2 STOP key

- Interrupt the measuring run

- Delete an error code

- If input of a mode of operation is completed with the STOP key, the new state is deselected automatically and the former state is re-established.

3 Function keys (see Fig. 9 to 11)

4 Display (see Fig. 12 to 15)

Fig. 9 Function keys on the left

1 Function key for distance rim / machine

2 Function key for rim width

3 Function key for rim diameter

Fig. 10 Function keys in the center

4 PRO MATCH

- Starts an optimisation program (LED PRO MATCH lights).

- In the Pro-Match program (OP program): enter valve position.

5 CLEAR/RESTORE

CLEAR (key pressed briefly): Setting the factory adjusted modes of operation. All settings are deleted and the display returns to standard.

RESTORE (key pressed for 3 seconds): Restores all modes the way they were before clear was pressed.

6 CALIBRATE/CODE

CALIBRATE (key pressed briefly): Sets the machine in the user calibration mode (see § 13. User calibration).

CODE (key pressed for 3 seconds): Switches to changing modes of operation.

7 G/OZ

Switches over the weight unit for unbalance readings (grams or ounces).

G Readings in grams **Oz**

Readings in ounces

When the machine is switched on the weight unit set with code C3 is active.

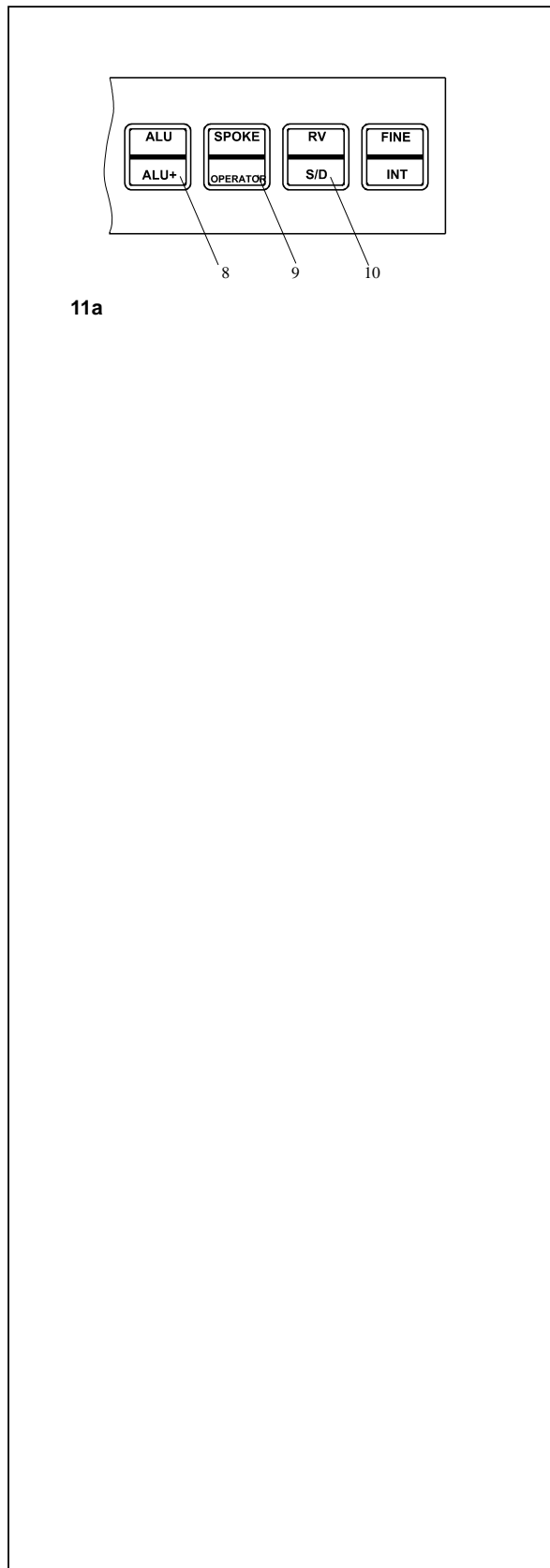

Fig. 11a Function keys on the right

8 ALU/ALU+ toggle key (ALU key) for balancing modes.

ALU (key pressed on top):

Toggles through the ALU and standard balancing modes. While in any ALU mode the ALU status LED lights.

ALU+ (key pressed on bottom):

Sets the machine in the ALU+ mode. This enables the automatic gauge arm for distance and rim diameter to measure first the left-hand distance and then the righthand hidden weight. Pressing this key disables one-plane and patch balancing and enables only hidden weight balancing.

First push: Enables lefthand hammer-on weight and lights lefthand hammer-on LED for balancing mode ALU 3P in wheel position display. Second push: Enables lefthand adhesive weight and lights

lefthand adhesive weight LED for balancing mode ALU 2P.

Third push: Returns to standard balancing

9 SPOKE/OPERATOR

SPOKE: Enters the number of spokes for the hidden spoke placement mode.

Keep the key pressed on top and rotate the wheel to set, or change, the number of spokes.

When the key is pressed without rotating the wheel, the current setting is entered.

OPERATOR: Recalls and stores wheel profiles. **RCL:**

Keep the key pressed on bottom. RCL (recall) comes up in the left-hand section of the display and 1 comes up in the right-hand section for the first wheel profile to be stored.

Keep the key pressed on bottom and rotate the wheel. Profiles 2 through 4 are read out in the right-hand display. The stored wheel profile is entered once the key is released.

STO: If a wheel profile is to be stored, keep on pressing the key after the rcl readings have come up and continue rotating the wheel. Now STO (store) comes up in the left-hand display, and # 1 through 4 can be set in the right-hand display by rotating the wheel. The current profile is stored once the key is released.

10 RV-S/D

RV (key pressed on top):

Changes the fine resolution to increments for RV/Light truck.

- Switches resolution to 2 instead of 1/4 ounce.
- Switches suppression minor unbalance readings to a selectable value (using service code).

Readouts stay in RV mode until deselected by pressing the key again.

S/D (key pressed on bottom):

- Function key to select display of dynamic or static unbalance (S/D key).

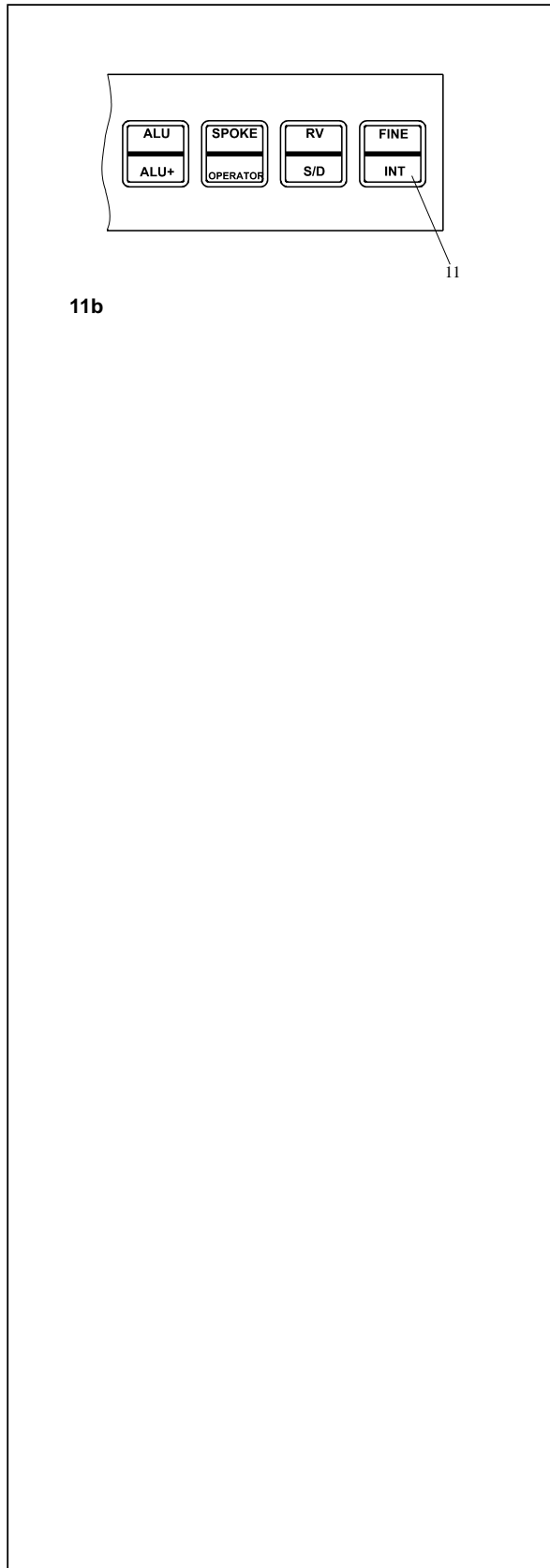

Fig. 11b Function keys on the right

11 FINE/INT

FINE (pressed on top):

- Show amount reading with higher resolution: 1 gramme instead of 5 grams or 0.05 oz instead of 0.25 oz (only for as long as the key is pressed)
- Display residual wheel unbalance below the threshold for suppression of minor unbalance readings: As long as the key is pressed the suppression of minor unbalance readings is switched off and the actual unbalance in the wheel is read out.
- Display unbalance for standard balancing mode: if balancing mode Alu 1 to Alu 5 is selected, press and hold the FINE key and then press the function key for balancing mode (ALU, ALU+). The unbalance readings switch over to those for standard balancing mode and the relative rim symbol appears.

- In the OP and Un programs the FINE key serves as change-over key. **INT** (pressed on bottom):
Switches to the patch balance mode.

All wheel data must have been entered. In addition the height-to-width ratio specified on the tire has to be entered by pressing the diameter key and rotating the wheel.

Readout display changes to single-plane. Both location displays are active and work in parallel. Distance and diameter dimensions have no effect and are preset to nominal values. All special functions are inactive and cannot be selected.

Controls and displays

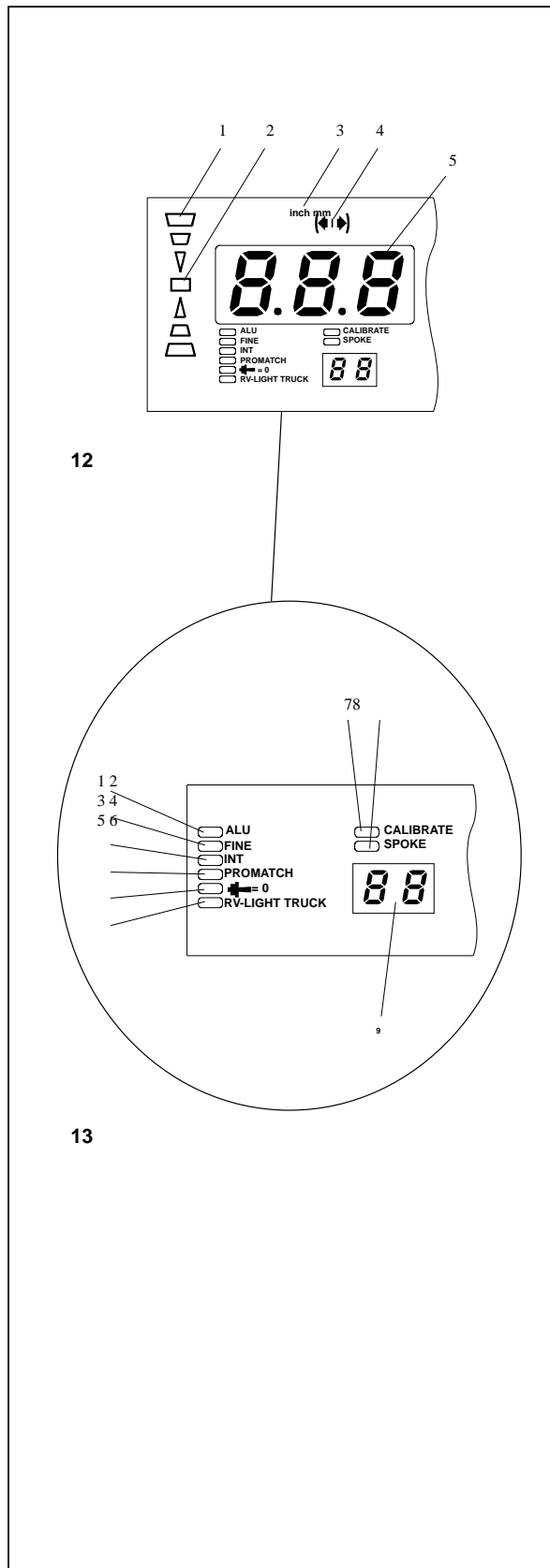

Fig.12 Display panel - left section

1 Direction indicator of left correction plane

2 Indicates when **correction position in the left correction plane** has been reached.

3 Inch/mm

The unit of measurement (inch or mm) is chosen by using the rim width key.

4 Rim width Symbol

Lights whenever width key is pressed.

5 Digital Display for left correction plane to show:

- rim width
- amount of unbalance of left correction plane
- amount of static unbalance
- error codes
- C codes
- balancing mode in plain language (upon operation of ALU key)
- STO, RCL of wheel profiles

Note: Error codes are read out in both digital displays.

Fig. 13 Status LEDs

1 ALU: Any ALU balance mode is selected

2 FINE: FINE key is pressed (cancels suppression of small imbalances). Display changes to normal resolution as soon as key is released.

3 INT: Patch Balance is selected. All special functions (including FINE) are inactive and cannot be selected.

4 PRO MATCH is selected.

5 **←= 0** Compensation run has been carried out

6 RV/LIGHT TRUCK resolution is selected.

7 CALIBRATE: Operator calibration mode is entered or programmable interval is reached.
The LED is automatically activated after 5000 measuring runs and alerts the operator that operator calibration is recommended. The LED remains on until the operator completes the operator calibration.

8 SPOKE: Hidden spoke placement (HSP) mode is selected.

9 Number of spokes

Number of spokes for hidden spoke placement. Holding the SPOKE key pressed rotate the wheel to set the number of spokes between 3 and 12.

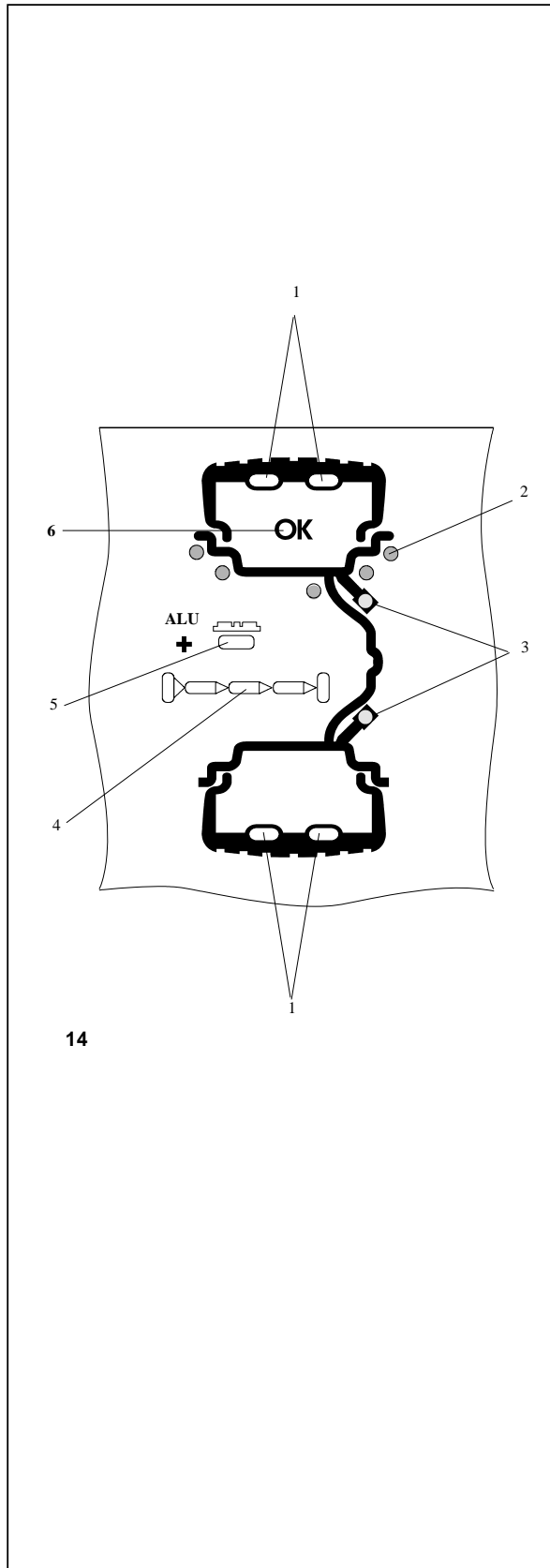

14

Fig.14 Display panel - central section

1 Measuring run indicators flash alter-

- nately in top and bottom panel
- during measurement after pressing the START key
- during PRO MATCH

2 Possible weight fitting positions LEDs change with successive pushes of the ALU key.

3 Valve stems

- Top valve stem flashes during PRO MATCH when valve must be positioned perpendicular to the main shaft.
- After the valve has been placed perpendicular to the main shaft and the PRO MATCH key is pressed, the LED is turned off.

4 SAPE symbol

- As the distance lever is moved the first bar and gradually the remaining bar segments light up. On reaching the correction position, the segment furthest to the right lights up and the speaker beeps.
- The symbol lights up when the weight fitting position is first entered and later relocated.

Note

When the wheel is rotated manually, the SAPE symbol will not light up.

5 ALU+ lights whenever ALU+ is chosen.

6 OK

lights whenever in two-plane mode both imbalance readouts are 0.00.

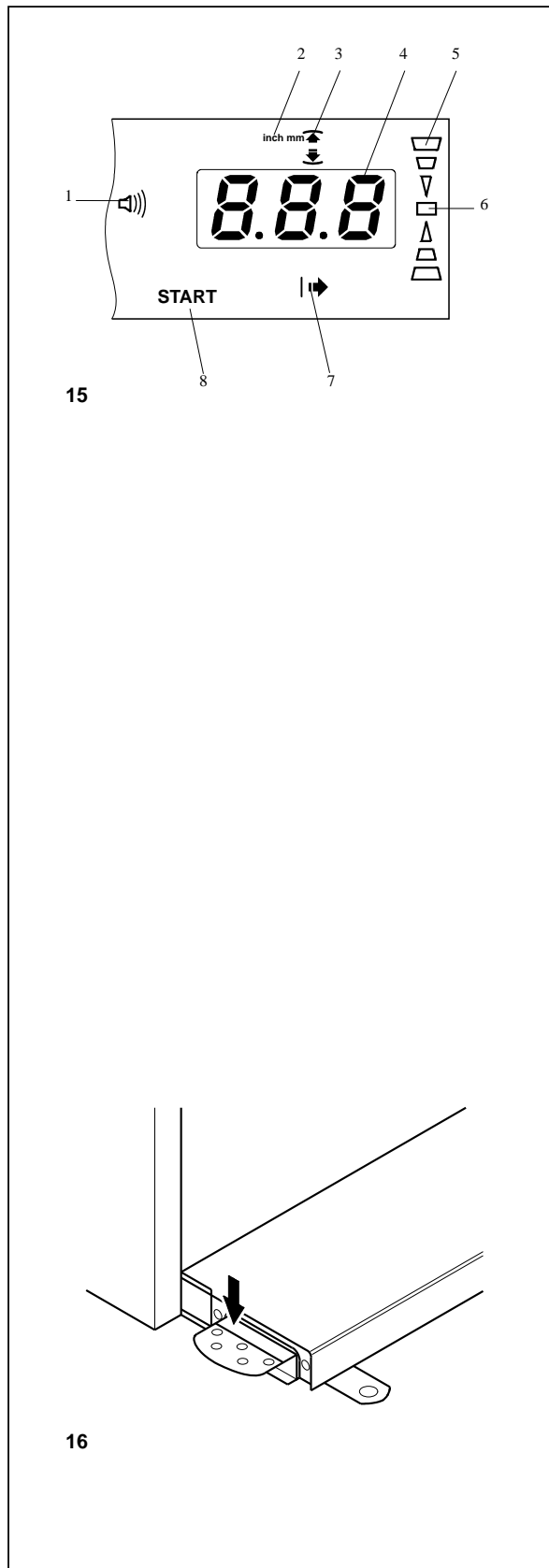

Fig. 15 Display panel - section on the right

1 Loudspeaker symbol

2 inch/mm

The unit of measurement (inch or mm) is chosen by using the rim diameter key.

3 Rim diameter

lights whenever rim diameter key is pressed.

4 Digital display of right correction plane to show:

- rim diameter
- distance rim/machine (always in mm)
- amount of unbalance of right correction plane
- state of modes of operation or preset limit values

5 Direction indicator of right correction plane

6 Indicates when **correction position in the right correction plane** has been reached.

7 Distance machine/left correction plane

lights whenever distance key is pressed or gauge arm for distance and rim diameter is moved.

8 START

flashes when the START key is to be pressed during pro match and operator calibration.

Fig. 16 Pedal of main shaft lock

The main shaft is locked when the pedal is depressed. This will facilitate tightening or untightening of the clamping nut, as well as retaining the wheel in correction position for correct fitting of the balance weights.

This lock is designed only to facilitate orientation of the wheel and must not be used for braking the main shaft.

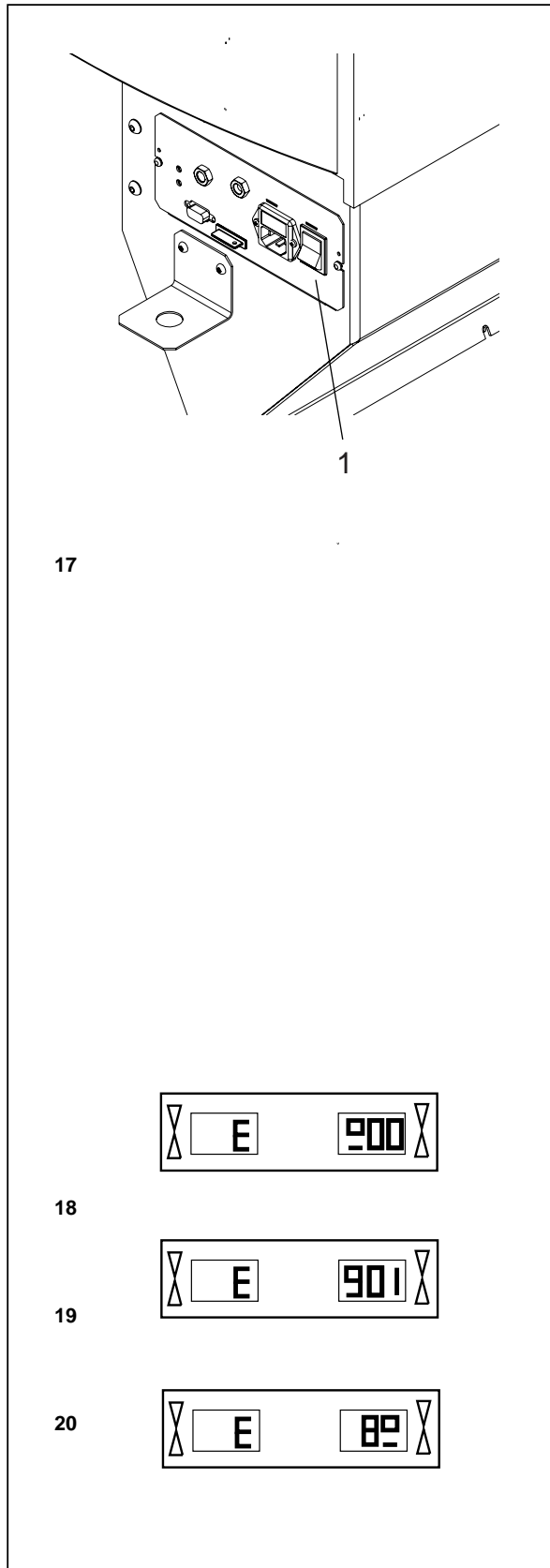

5. Turning on the machine

When switched on by the switch (**Fig. 17, item 1**) the electronic unit performs a number of self-tests. On successful completion of these tests a melodious three-tone signal is given. OK is read out on the displays, and the code number of the program version is briefly viewed on the display; then both displays show wheel dimensions which were entered before and are still stored in the electronic memory.

As long as the machine is carrying out the self-tests, no inputs and no other operations whatsoever must be made. During this starting phase the machine must not be subjected to even the slightest vibration.

The electronic unit is factory-adjusted to the following modes of operation, which are available after turning on:

- car wheel with nominal dimensions in inches width 6.5" and diameter 15.0"
- entry of rim data in inches
- display of amount of unbalance in 1/4 ounce increments
- suppression of minor unbalance readings (limit set to 1/4 ounce)
- automatic braking of wheel when guard is opened during the measuring run
- compensation of adapter unbalance switched off
- start of measuring run by START key only

Error codes at power on

If an error code occurs it must be acknowledged by pressing the STOP key. No audible signal is given.

The following malfunction codes may occur at power-on:

E900 - Fig. 18

Unknown machine model.

E901 - Fig. 19

The machine is not calibrated.

E89 - Fig. 20

A key is jammed at power-on.

- Find and release the jammed key, call service if necessary.

Turning on the machine

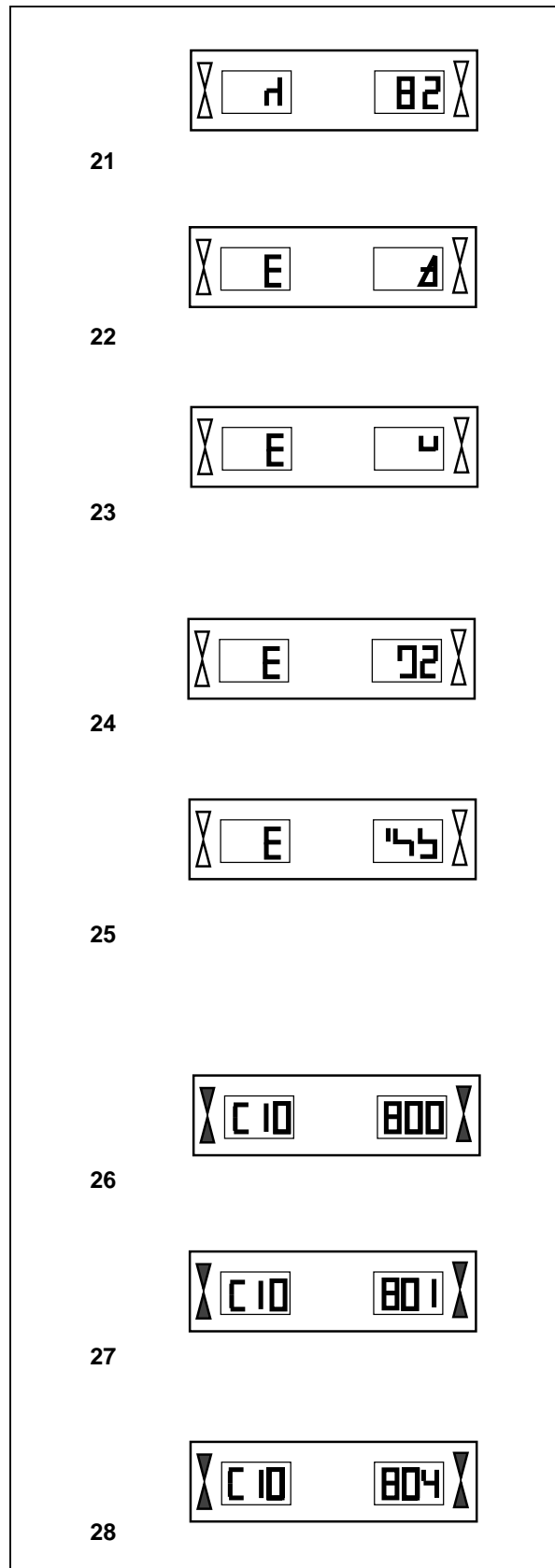

H82 - Fig. 21

The self-test was disturbed (e.g. by rotating the wheel). The message is displayed for 3 seconds, after which the measurement is repeated (max. 10 times), or aborted by pressing the STOP key.

E3 - Fig. 22

Gauge arm for distance and rim diameter is not in home position.

- Move gauge arm to its home position. Press the STOP key.

E4 - Fig. 23

Width gauge arm is not in home position.

- Move gauge arm to its home position. Press the STOP key or the ESC key to continue.

E92 - Fig. 24

During the second attempt the gauge arm for distance and rim diameter was still not in the home position. The gauge arm is rendered inoperative.

- Wait 3 seconds, or press the STOP key to continue.

E145 - Fig. 25

The contents of both permanent memories are different (but both contain valid data).

Fatal error codes

The self-test program has detected an error and displays an alphanumeric code consisting of six digits and/or letters.

Note

The displayed error codes refer only to the internal line voltage of the machine.

C10 800 - Fig. 26

Line voltage too low. Balancing is feasible if the motor can drive the main shaft to the measuring speed. Wheel data may be lost.

- Connect the machine to 115-120 V AC.

C10 801 - Fig. 27

Line voltage too high. Damage to the electronic unit of the machine is likely!

- Turn off machine immediately.

Damage is not covered under warranty.

C10 804 - Fig. 28

Line voltage too high. Damage to the electronic unit of the machine is likely!

- Turn off machine immediately.

Damage is not covered under warranty.

6. Clamping the wheel

6.1 Fitting the wheel adapter on the main shaft

Fig. 29 Fitting the wheel adapter

29.1 MZV-4 cone adapter for rims with center bore location, or at least sufficiently accurate center bore. Various accessories are available for this wheel adapter.

29.2 Adapters for closed rims, or stud hole located rims. Various accessories are available for this wheel adapter.

- 1 Cone of the main shaft
- 2 Basic body of the wheel adapter
- 3 Fastening screw (width across flats 14 mm)

- Before fitting the wheel adapter clean the cone of the main shaft (**Fig. 29, item 1**) and the inner cone of the wheel adapter.
- Slide the wheel adapter onto the cone of the main shaft so that the head of the hexagon socket head cap screw attached to the end of the cone engages with one of the recesses in the basic body of the adapter (**Fig. 29, item 2**).
- Tighten the wheel adapter using the fastening screw (**Fig. 29, item 3**).

6.2 Performing a compensation run

All clamping and centring means are balanced in our works to within a certain tolerance.

To compensate for any residual unbalance that might be left in the clamping means, it is recommended that an electrical compensation run be performed (also see § 10. Changing modes of operation). This mode cannot be transferred into the permanent memory.

This mode of operation is retained until deleted via code C4, by starting an Pro-Match run or readjustment, or by switching off the machine.

- Press and hold the CODE key (Fig. 10, item 6) and rotate the main shaft to set C4 in the display.

- Press the START key.

The compensation run takes longer than a regular measuring run. Once the compensation run is completed, C4 is read out in the left display, 1 is read out in the right display, and the compensation LED (Fig. 13, item 12) appears in the middle.

When another clamping means is used:

- Repeat the compensation run

or

- cancel compensation by pressing and holding the FINE key (Fig. 11b, item 11) and rotating the wheel, or by switching the machine off for a few seconds

In the right display, 0 is read out.

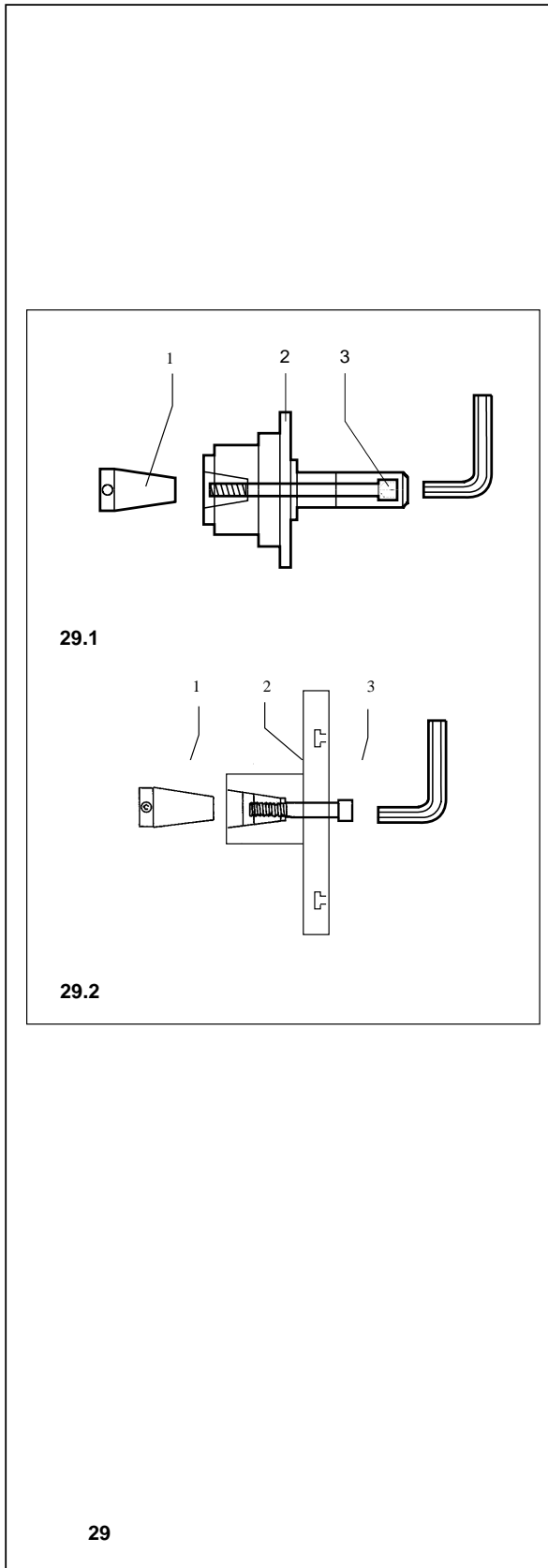

Clamping the wheel

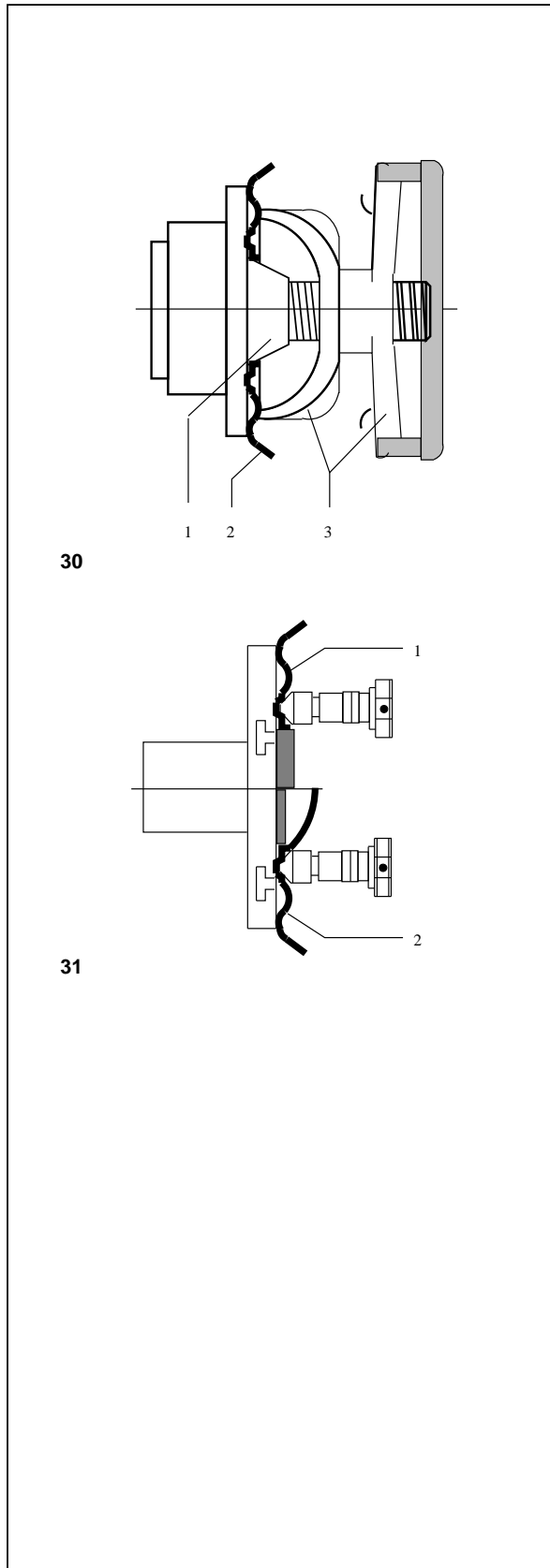

6.3 Clamping car and light-truck wheels

Fig. 30 Cone adapter to clamp center bore located wheels

- 1 Cone
- 2 Rim
- 3 Clamping head with clamping nut

Fig. 31 Universal clamping adapter for clamping stud hole located wheels or wheels with closed rim

- 1 Rim with center bore (center bore location)
- 2 Closed rim

7. Entry of balancing mode and wheel size

For determination of unbalance the following inputs have to be made:

- **balancing mode** (weight fitting position on rim)
- wheel size (**wheel width** and **diameter**)
- **distance** between machine and left correction plane

The wheel dimensions to be entered are usually given on the rim (in inches or mm on standard wheels, in mm on TD or TRX wheels). Rim diameter is also given on the tire.

Recommendation

Enter the rim dimensions using the geodata gauge arms because this allows an accurate detection of the dimensions and because the position for adhesive weights can be precisely located after the measuring run.

By means of the geodata width gauge arm the rim width can be measured and entered automatically.

Rim width is entered manually by pressing and holding the relative function key (**Fig. 32, item 2**) and rotating the wheel until the desired value is read out. On releasing the function key the input is retained until another input is made.

The distance between left correction plane/machine and the rim diameter are usually entered using the geodata gauge arm for distance and rim diameter.

The distance may also be entered by pressing and holding the relative function keys (**Fig. 32, items 1 and 3**) and rotating the wheel until the desired values are read out. On releasing the function key the input is retained until another input is made.

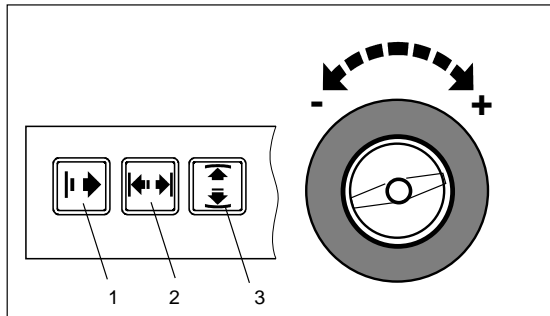

32

Entry of balancing mode and wheel size

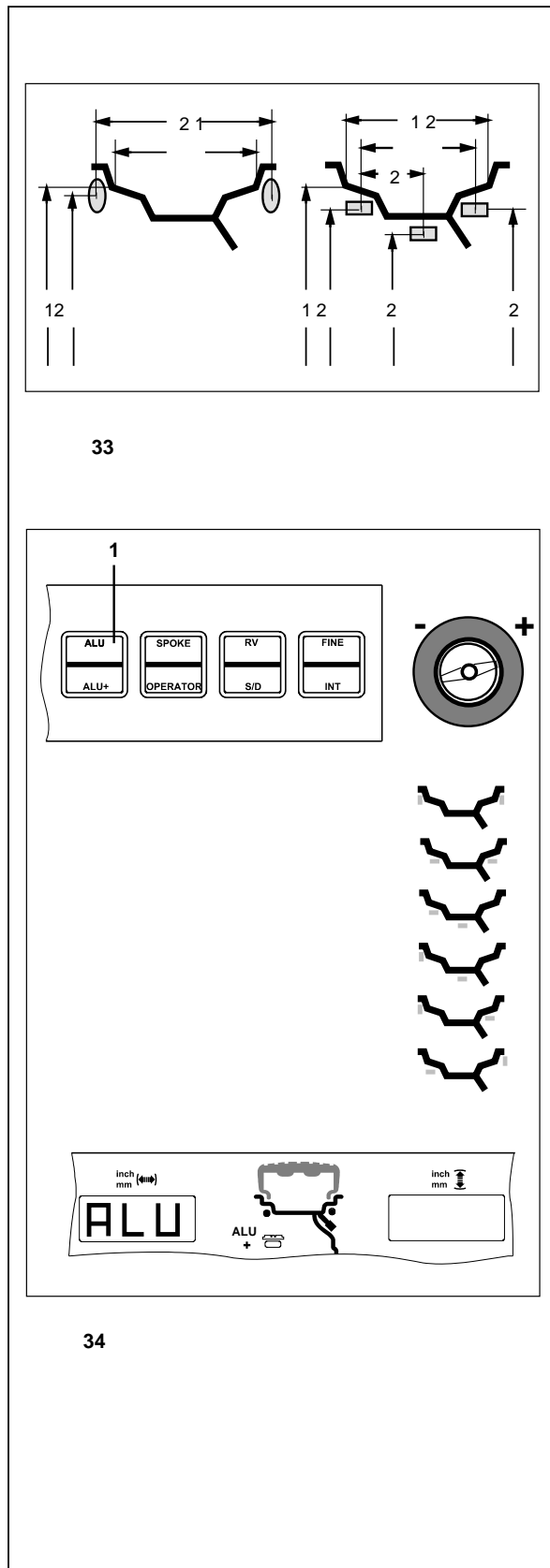

33

34

7.1 Balancing modes

The use of different types on a standard (alloy) wheel and the resulting different fitting positions of the weights on the rim produce differences between the rim data which have been entered and the actual correction dimensions.

Fig. 33 Possible positions of the balance weights
- nominal rim data / actual correction data

- 1 Nominal rim dimensions to be entered
- 2 Actual correction data (center of gravity of weights) which are used for determination of unbalance

The mode chosen is read out on the display, showing the relative rim symbol (**Fig. 34**), or on the digital displays when the Alu key is pressed (reading e.g. Alu 1).

- Press and hold the Alu key (**Fig. 34, item 1**) and rotate the wheel to set the desired balancing mode (weight fitting positions - **Fig. 34**).
- Release the Alu key as soon as the desired mode is read out.

Fig. 34 Rim symbols showing weight position

- nor.** Standard balancing mode where hammer-on weights are attached to the rim flanges
- Alu 1** Fitting of adhesive weights to the bead seats
- Alu 2** Adhesive weights - hidden adhesive weight attached (**Alu 2P**) in the rim so as not to impair the decorative appearance of alloy wheels or to balance PAX wheels
- Alu 3** Hammer-on weight on left rim flange, adhesive weight (**Alu 3P**) attached in hidden position in the rim disc
- Alu 4** Hammer-on weight on left rim flange, adhesive weight attached to right bead seat
- Alu 5** Hammer-on weight on right rim flange, adhesive weight attached to left bead seat

Entry of balancing mode and wheel size

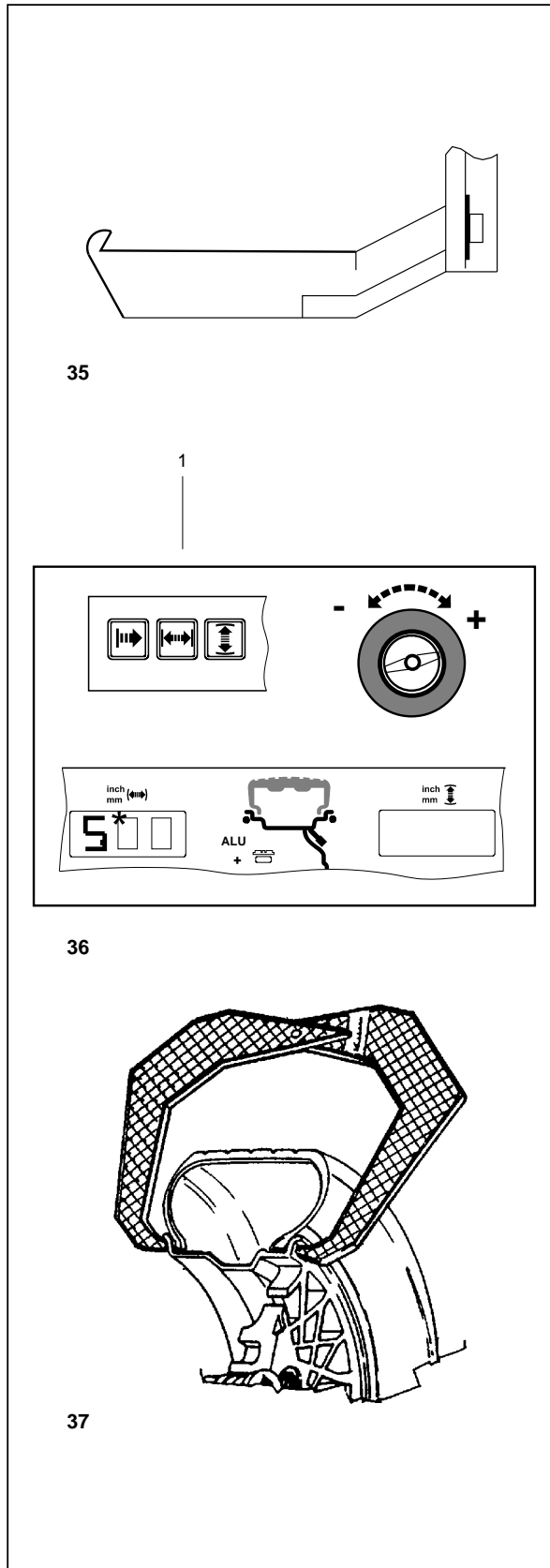

7.2 Input of wheel dimensions for the standard balancing mode

If several wheels with identical wheel size are balanced in succession, it is only necessary to enter the data for the first wheel. It will remain stored until new entries are made.

7.2.1 Determination and input of rim width Automatic determination of rim width using the geodata width gauge arm

- Pull the geodata width gauge arm down, apply the gauge head (**Fig. 35**) on the rim flange, and hold in that position.

Within short an audible signal confirms that the rim width has been stored automatically.

- Re-place the gauge arm in its home position.

Upon operation of the relative function key (**Fig. 36, item 1**) the rim width can be read out once again.

Manual input of rim width

Use the optional rim width callipers (**Fig. 37**).

Fig. 36 Input of rim width

- To enter the rim width, press and hold the function key (**Fig. 36, item 1**).
- Rotate the wheel while the key is pressed in order to set the value for the rim width on the display, and then release the key.

The rim width will be shown until the unbalance values are displayed.

- On completion of the input the measuring run can be started.

Entry of balancing mode and wheel size

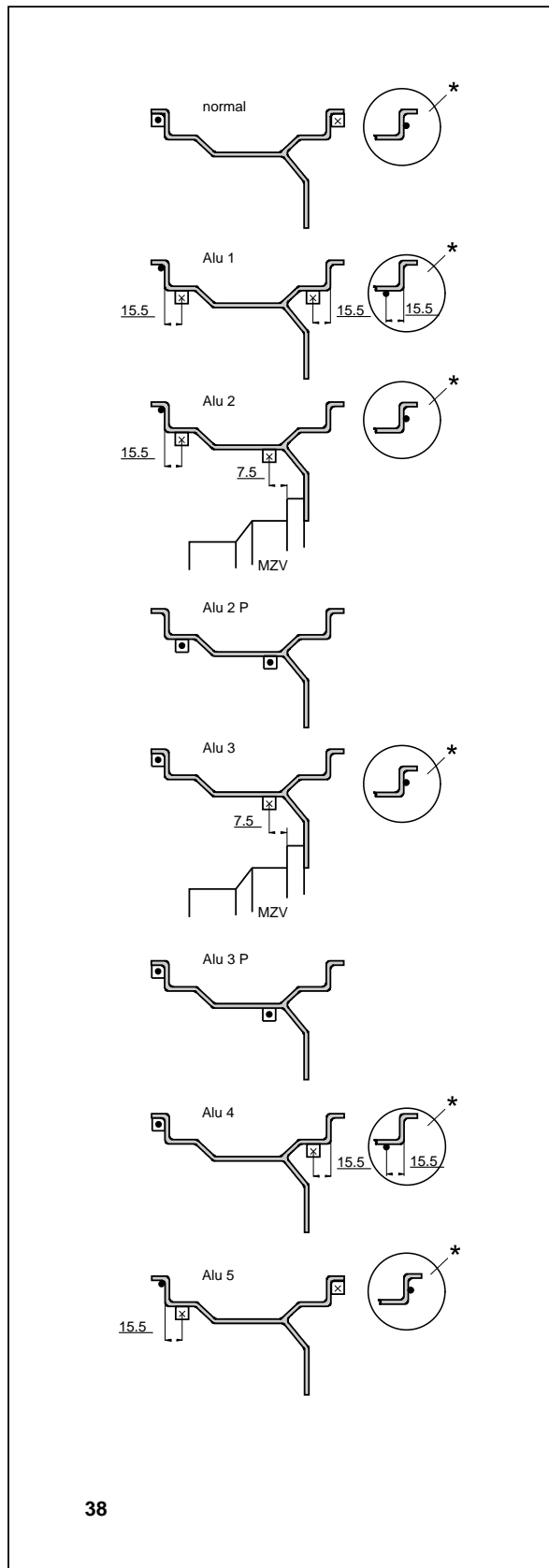

38

7.2.2 Gauge head applications

By means of the geodata gauge arm for distance and rim diameter the distance between left correction plane/machine and the rim diameter can be measured and entered automatically.

In order to be able to determine unbalance in a single measuring run, the rim dimensions have to be entered correctly.

* By means of the width gauge arm the rim width can be

scanned at the right-hand rim flange or right-hand bead seat and automatically entered in all balancing modes except Alu 2P and Alu 3P.

Fig. 38 shows correct application (with and without adhesive weight) of the gauge on various rims and for various weight positions. There are either one, or two positions where the gauge has to be applied.

normal Standard balancing mode where hammer-on weights are attached to the rim flanges

Alu 1 Attachment of adhesive weights to the bead seats

Alu 2 Adhesive weights - adhesive weight on bead seat, hidden adhesive weight attached in the rim: The correction planes for the adhesive weights are determined automatically by the machine

Alu 2P Adhesive weights - adhesive weight on bead seat, hidden adhesive weight attached in the rim; The correction planes for the adhesive weights can be determined exactly

Alu 3 Hammer-on weight on left rim flange, adhesive weight attached in hidden position in the rim; The correction plane for the adhesive weight is determined automatically by the machine

Alu 3P Hammer-on weight on left rim flange, adhesive weight attached in hidden position in the rim; The correction plane for the adhesive weight can be determined exactly

Alu 4 Hammer-on weight on left rim flange, adhesive weight attached to right bead seat

Alu 5 Hammer-on weight on right rim flange, adhesive weight attached to left bead seat

Entry of balancing mode and wheel size

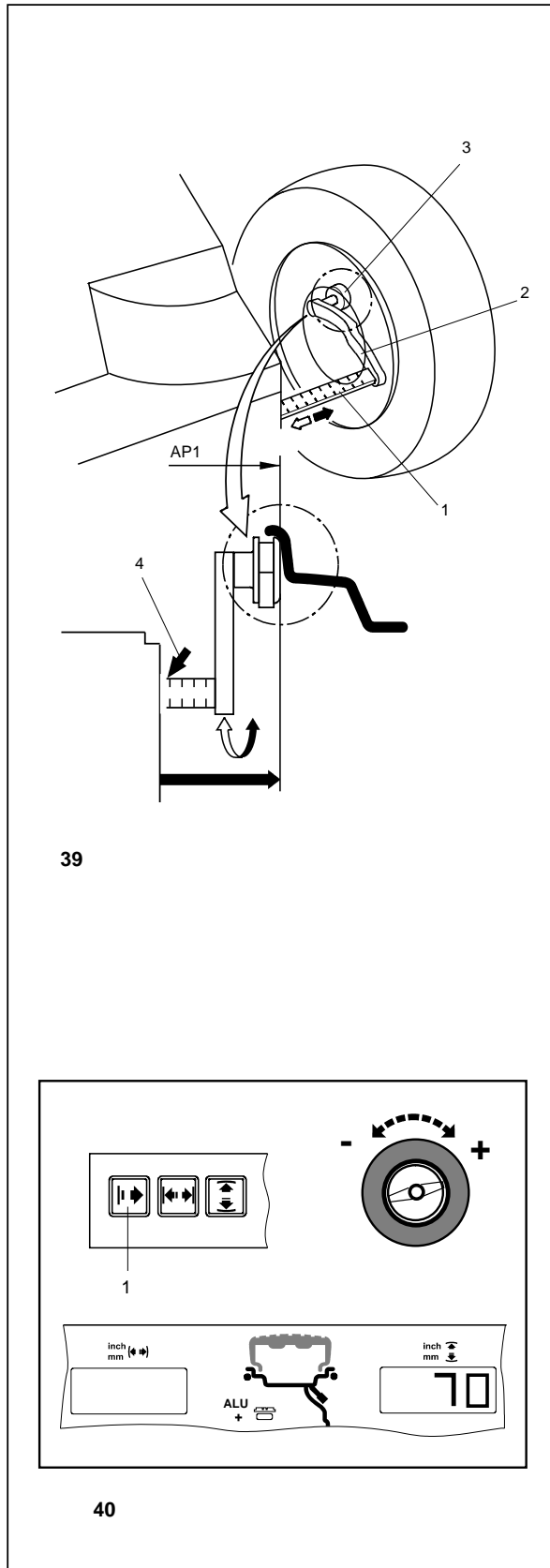

7.2.3 Determination of distance and diameter

For the balancing modes nor., Alu 1, Alu 2, Alu 3, Alu 4 and Alu 5 the correction dimensions are derived from the dimensions by subtraction or addition of correction values.

Fig. 39 Gauge for distance and rim diameter

- 1 Scale for distance, mm only - scale with 2 mm graduations
- 2 Gauge arm with pointer
- 3 Pointer
- 4 Reference edge for distance reading

The distance between left correction plane and machine and the rim diameter are usually entered automatically using the integrated gauge arm, but may also be entered by pressing and holding the menu keys for rim diameter and distance and rotating the wheel until the desired value is read out.

Automatic determination of distance and diameter

- Pull the gauge arm for distance and diameter (**Fig. 39, item 2**) out of the cabinet, apply the gauge (**Fig. 39, item 3**) on the rim flange as shown in Fig. 39, and hold in that position.

An audible signal confirms that distance and rim diameter have been stored automatically.

- Re-place the gauge arm in its home position.

Upon operation of the key the distance and the diameter can be read out once again.

Manual input of distance rim/machine

If automatic determination of the distance rim/machine is not possible (error code E92), the distance can be determined manually in balancing modes normal, Alu 1, Alu 2, Alu 3, Alu 4 and Alu 5.

Attention

In balancing modes Alu 2P and Alu 3P manual input of the distance rim/machine will produce an incorrect measurement result.

- Pull the gauge arm (**Fig. 39, item 2**) out of the cabinet, apply the gauge (**Fig. 39, item 3**) on the rim flange as shown in **Fig. 39** and hold in that position.
- Note the distance shown on the scale (**Fig. 39, item 4**).
- Return the gauge arm to its home position.
- Press and hold the key for distance (**Fig. 40, item 1**).
- Holding the key pressed, rotate the wheel to enter the distance previously indicated on the scale.

- Release the key.

By pressing the key the distance can be viewed once again.

Entry of balancing mode and wheel size

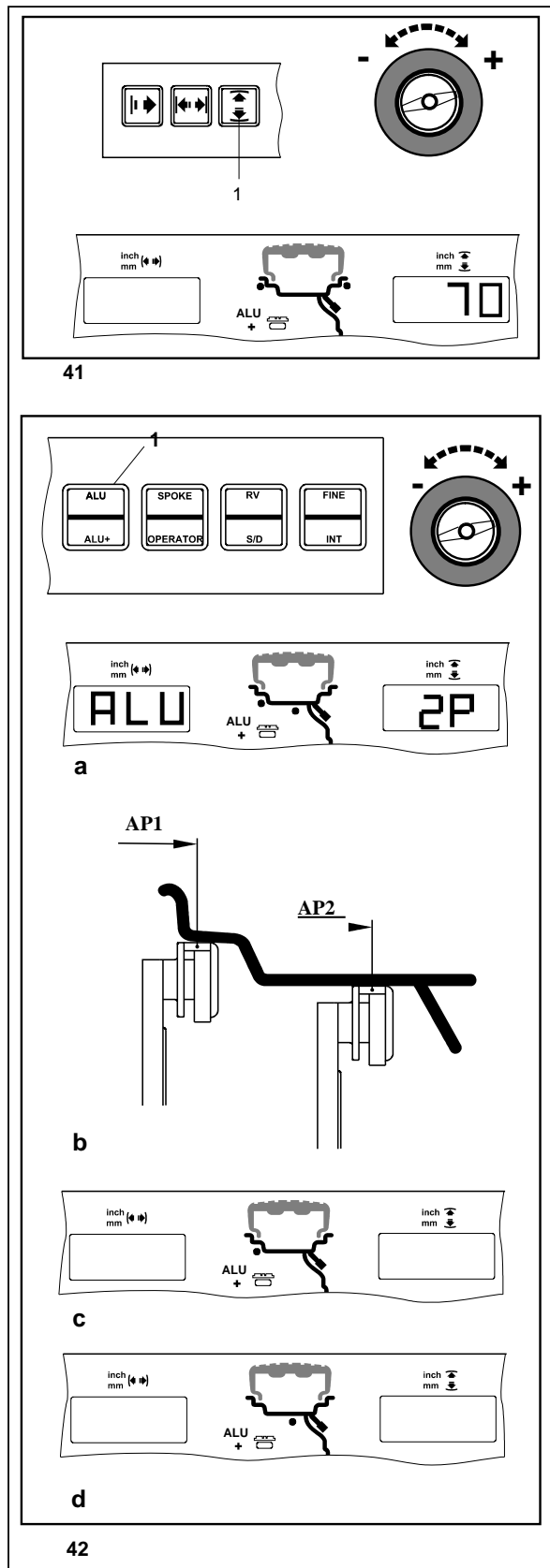

Manual input of diameter

- Note the wheel diameter on the rim or tire.
 - To enter the wheel diameter, press and hold the function key (**Fig. 41, item 1**).
 - Rotate the wheel while the key is pressed in order to enter the previously noted diameter.
- Having made the input release the function key.

7.2.4 Determining the position of the hidden weights (Alu 2P)

Note

Enter rim width before determining the position of the weights.

Fig. 42 Scanning of the exact correction dimensions

- 1 Alu key
 - a Selection of balancing mode Alu 2P
 - b Measurement procedure
 - c Application position AP1
 - d Application position AP2

- To set the desired balancing mode press and hold the Alu key (**Fig. 42, item 1**).
- Holding the key pressed rotate the wheel until mode Alu 2P is shown (**Fig. 42a** - the left weight symbol is displayed as long as the key is pressed). Release the Alu key as soon as the desired balancing mode is read out.

Recommendation

Clamp an adhesive weight in the weight holder of the gauge with the cover film of the weight being in top position prior to scanning the correction dimensions.

- To determine the gauge application position **AP1**, pull the gauge arm for distance and diameter out of the cabinet, apply the gauge on the rim in the center of the intended weight position as shown in **Fig. 42b, item AP1** and hold in that position.

The symbol for the outer weight is viewed on the display (**Fig. 42c**).

- Approach the gauge to application position **AP2** and hold in that position.

The symbol for the inner weight is viewed on the display (**Fig. 42d**). An audible signal is given when the distance has been stored.

- Return the gauge arm for distance and diameter to its home position.
- Start the measuring run.

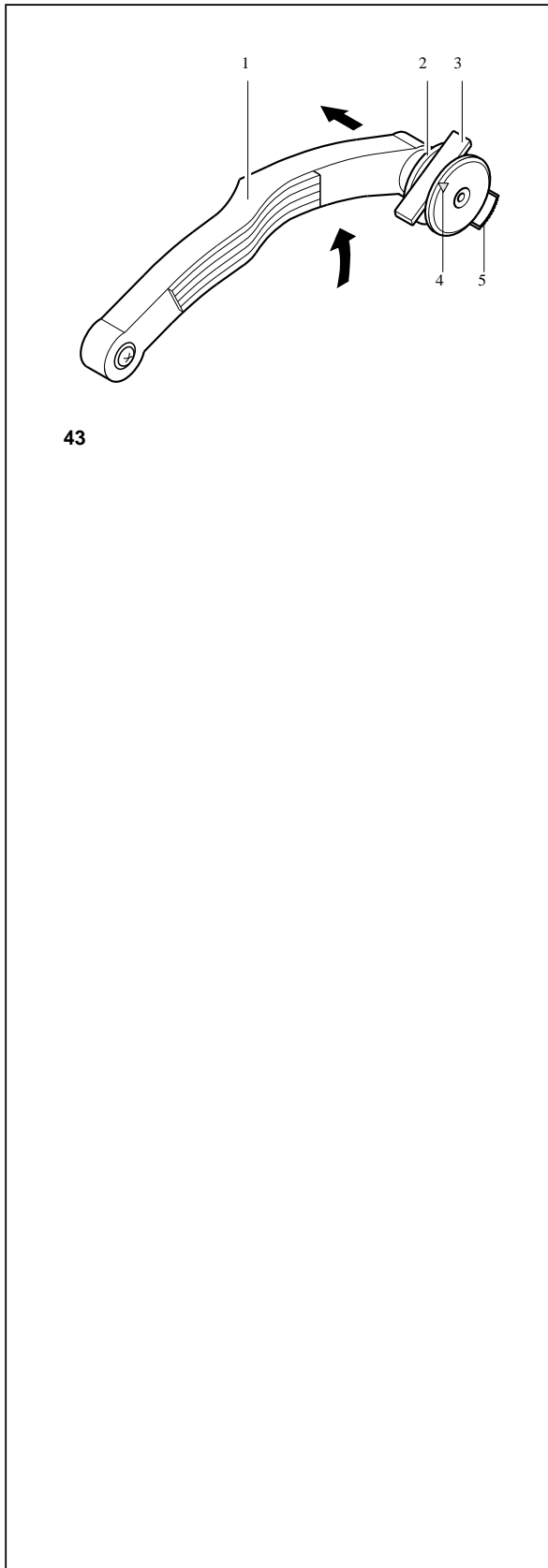

43

Fitting of balance weights

- Select an adhesive weight for **AP1** and adjust it to the wheel radius by bending.
- Clean the position before attaching the adhesive weights.
- Raise the gauge arm (**Fig. 43, item 1**) and pull the holding ring of the gauge (**Fig. 43, item 2**) inwards.
- Insert the adhesive weight (**Fig. 43, item 3**) into the gauge with the protective tape facing upwards to the arrow (**Fig. 43, item 4**).
- Press the adhesive weight firmly against the gauge and remove the protective tape from the weight.
- Pull the gauge arm towards application position **AP1**.

The display shows the dimension for the first distance, which decreases as the gauge is approached. At 0 ± 1 an audible signal is given to show that **AP1** has been reached.

- Press the pedal of the main shaft lock to hold the wheel in this position.
- Swing the gauge arm out towards the rim and press the weight firmly against the rim using the ejector (**Fig. 43, item 5**).
- Swing the gauge arm in and return it to its home position.
- Firmly press the adhesive weight on the rim by hand.

Fit the second adhesive weight for **AP2** in the same manner.

Entry of balancing mode and wheel size

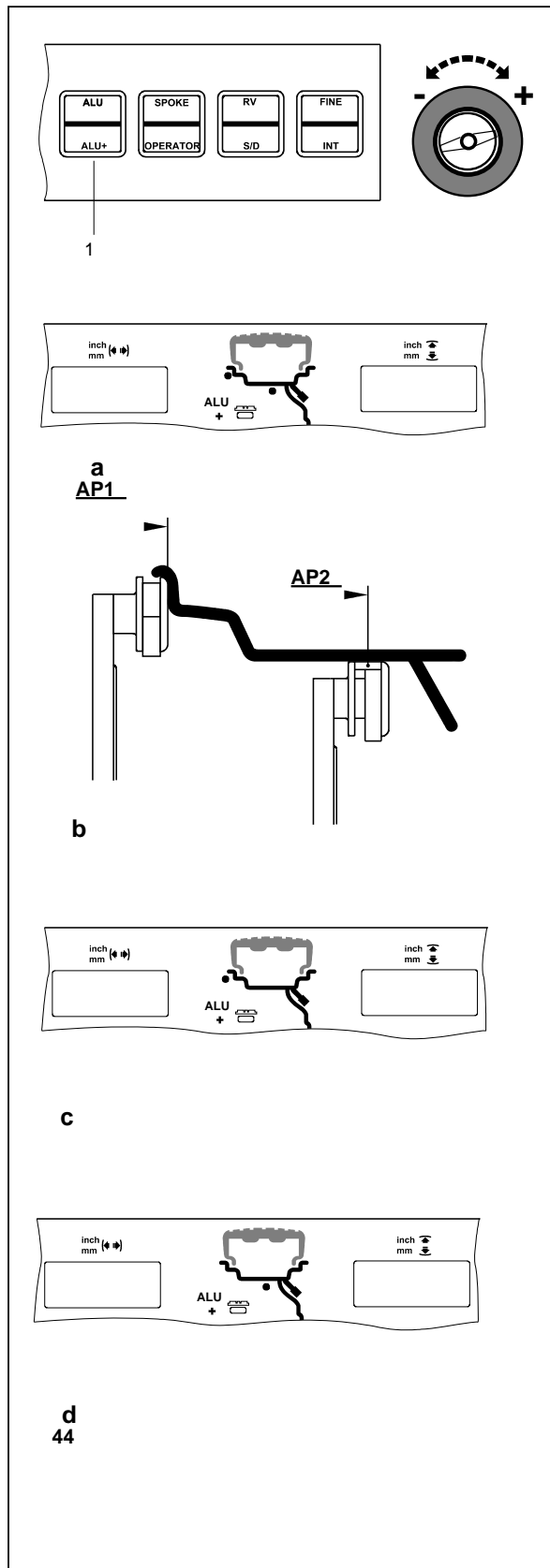

7.2.5 Determining the position of the hidden weights (Alu 3P)

Note

Enter rim width before determining the position of the weights.

Fig. 44 Scanning and input of the dimensions

1 Alu key

a Selection of balancing mode Alu 3P

b Measurement procedure

c Application position AP1

d Application position AP2

- To set the desired balancing mode press and hold the Alu key (**Fig. 44, item 1**).
- Holding the key pressed rotate the wheel until mode Alu 3P is shown (**Fig. 44a** - the left weight symbol is displayed as long as the key is pressed). Release the Alu key as soon as the desired balancing mode is read out.

Recommendation

Clamp an adhesive weight in the weight holder of the gauge with the cover film of the weight being in top position prior to scanning the correction dimensions.

- To determine the gauge application position **AP1**, pull the gauge arm for distance and diameter out of the cabinet, apply the gauge on the rim in the center of the weight position as shown in **Fig. 44b, item AP1** and hold in that position.

The symbol for the outer weight is viewed on the display (**Fig. 44c**).

- Approach the gauge to application position **AP2** and hold in that position.

The symbol for the inner weight is viewed on the display (**Fig. 44d**). An audible signal is given when the distance has been stored.

- Return the gauge arm for distance and diameter to its home position.
- Start the measuring run.

Entry of balancing mode and wheel size

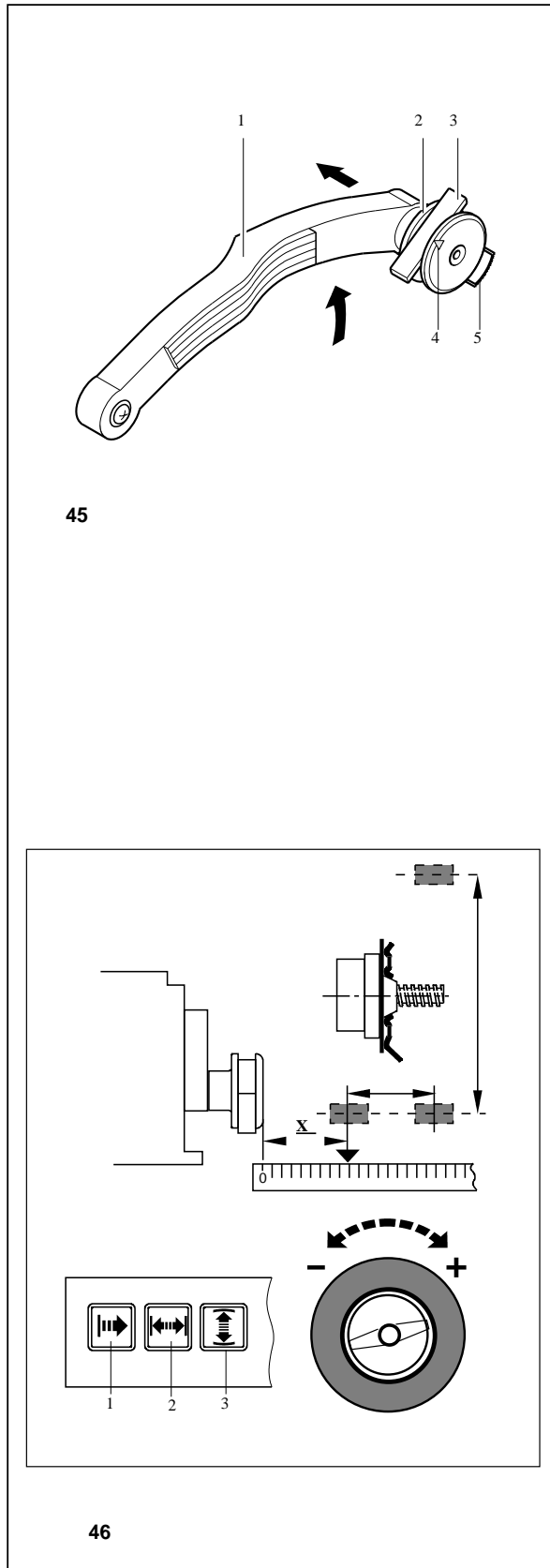

Fitting of balance weights

The weight for **AP1** is a hammer-on weight and is attached at 12 o'clock to the main shaft after indexing the wheel, as in the normal mode. The gauge arm stays in its home position.

The adhesive weight for **AP2** is as described below:

- Select an adhesive weight and adjust it to the wheel radius by bending.
- Clean the position before attaching the adhesive weights.
- Raise the gauge arm (**Fig. 45, item 1**) and pull the holding ring of the gauge (**Fig. 45, item 2**) inwards.
- Insert the adhesive weight (**Fig. 45, item 3**) into the gauge with the protective tape facing upwards to the arrow (**Fig. 45, item 4**).
- Press the adhesive weight firmly into the gauge and remove the protective tape from the weight.
- Pull the gauge arm towards application position **AP2**.

The display shows the dimension for the first distance, which decreases as the gauge is approached. At 0 ± 1 an audible signal is given to show that **AP2** has been reached.

- Press the pedal of the main shaft lock to hold the wheel in this position.
- Swing the gauge arm out towards the rim and press the weight firmly against the rim using the ejector (**Fig. 45, item 5**).
- Swing the gauge arm in and return it to its home position.
- Firmly press the adhesive weight on the rim by hand.

7.2.6 Special balancing operations

If none of the programmable balancing modes can be used:

- Measure the distance and the actual correction dimensions (center of gravity of balance weight to be attached) directly on the wheel (**Fig. 46**).
- Press and hold the key (**Fig. 46, item 1 - 3**) and rotate the wheel to set the values.
- Release the key as soon as the desired value is read out.



7.2.7 Input for display of static unbalance

For wheels which should only be balanced statically, only the correction diameter has to be entered.

Input is made as for standard wheels.

- Press and hold the diameter key and rotate the wheel to set the diameter values.
- Release the key as soon as the desired value is read out.

7.2.8 Store wheel profiles

Wheel profiles permit the storage of values for wheels that are balanced frequently so that the wheel data need not be entered again and again. This function is particularly useful for shops that frequently handle the same wheel types.

It is possible to store up to 4 wheel profiles via code **C18** and to select previously stored profiles via code **C17** (see § 10. Changing modes of operation).

The following values are stored:

- Wheel dimensions
- Values measured with the gauge arm
- Weight positions
- Positions for relocation

- Press and hold OPERATOR key (on bottom).

RCL comes up in the left-hand section of the display and 1 comes up in the right-hand section for the first wheel profile to be stored. Keep the key pressed on bottom and rotate the wheel. Profiles 2 through 4 are read out in the right-hand display. The stored wheel profile is entered once the key is released. If a wheel profile is to be stored, keep on pressing the key after the RCL readings have come up and continue rotating the wheel. Now STO (store) comes up in the left-hand display, and No. 1 through 4 can be set in the right-hand display by rotating the wheel. The current profile is stored once the key is released.

7.2.9 Correction of inputs after measurement

Upon operation of the FINE key the electronic unit accepts the new input, processes it and then reads out the corrected measured data without need to repeat the measuring run.

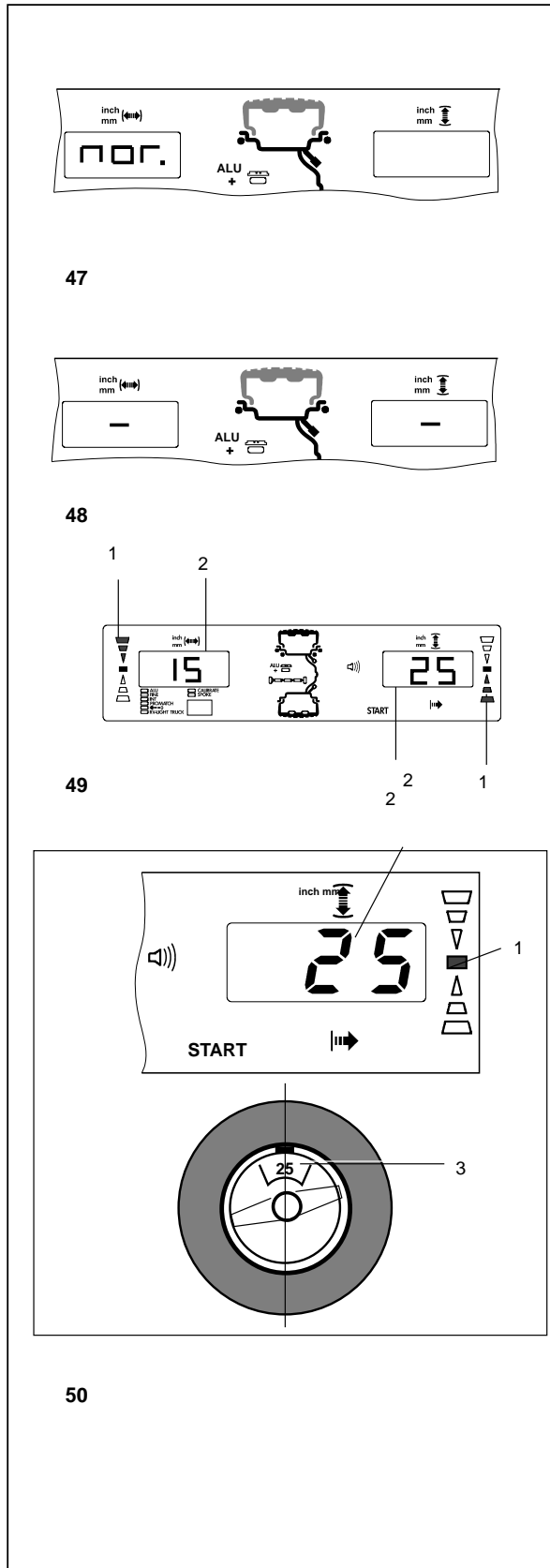

8. Balancing the wheel

Preparations:

- Compensation run carried out, if necessary (see § 6.2).
- Wheel correctly clamped (see § 6.3).
- Balancing mode chosen (see § 7.1).
- Distance and rim dimensions entered (see § 7.2).

If several wheels with identical nominal rim dimensions are balanced in succession, it is only necessary to enter the data for the first wheel. The inputs will remain stored until new data is entered.

8.1 Measurement

- Start the measuring run.
- Index the wheel into correction position following the direction indicated (**Fig. 49, item 1**).

On reaching the respective correction position only the two arrow-heads are visible (**Fig. 50, item 2**).

- In this position attach a balance weight in the correction position at the top of the rim, at 12:00 o'clock (**Fig. 50, item 3**).

For correct fitting of the balance weights see **Fig. 51, 53 and 56**.

Fig. 50 Example of display and correction of the righthand correction plane

- 1 Display of amount of unbalance
- 2 Display of correction position - only the arrow-heads light up
- 3 Position of balance weight on rim

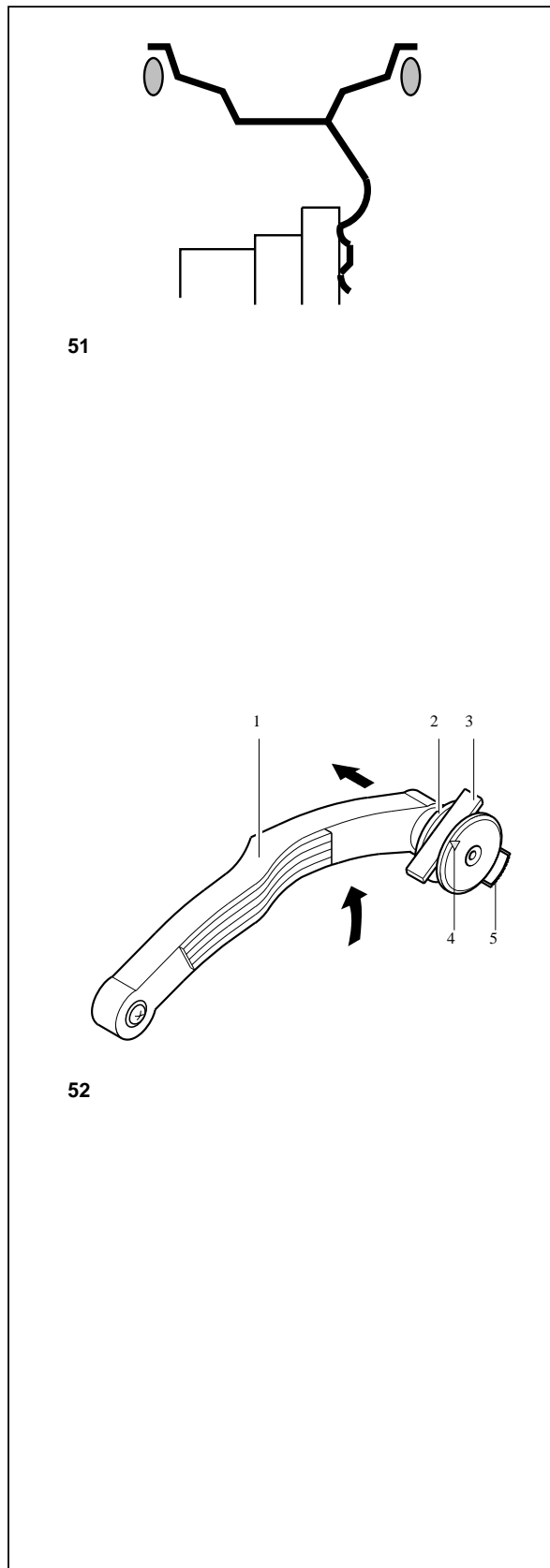

51

52

8.2 Fitting the balance weights correctly

Attaching of balancing weights for the balancing modes normal, Alu 1, Alu 2, Alu 3, Alu 4, and Alu 5 is specified and illustrated in this paragraph.

Fitting of balance weights for the balancing modes Alu 2P and Alu 3P is specified and illustrated in paragraphs 7.2.4 and 7.2.5.

8.2.1 How to attach hammer-on weights

- If necessary, index the wheel to the exact correction position in the righthand correction plane. On reaching the correction position only the two arrow-heads light up (**Fig. 50, item 2**).
- Press the pedal of the main shaft lock to hold the wheel in this position.
- Attach the hammer-on weight in the correction position at the rim flange at 12:00 o'clock (**Fig. 51**).
- After balancing carry out a check run (see § 8.3).

8.2.2 How to fit adhesive weights using the gauge

Note

If an error code H20 is read out when the gauge arm is approached to the rim, there are no data for re-locating the correction plane (see §11. Error codes). This means that either an error was made in applying the gauge arm, or the adhesive weight cannot be fitted on the rim using the gauge. In this case refer to § 8.2.3.

- If necessary, index the wheel to the exact correction position in the left correction plane. On reaching the correction position only the two arrow-heads light up (**Fig. 50, item 2**).
- Press the pedal of the main shaft lock to hold the wheel in this position.
- Clean the wheel position before attaching the adhesive weights.
- Select an adhesive weight and adjust it to the wheel radius by bending.
- Raise the gauge arm (**Fig. 52, item 1**) and pull the holding ring of the gauge (**Fig. 52, item 2**) inwards.
- Insert the adhesive weight (**Fig. 52, item 3**) into the gauge with the protective tape facing upwards to the arrow (**Fig. 52, item 4**).
- Press the adhesive weight firmly against the gauge and remove the protective tape from the weight.
- Pull the gauge arm towards application position. The display shows the dimension for the first distance, which decreases as the gauge is approached. At 0 ± 1 an audible signal is given to show that the correction plane has been reached.

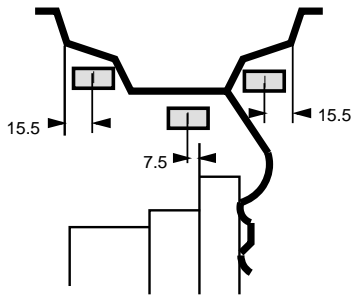

53

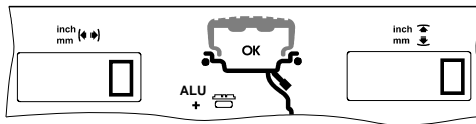

54

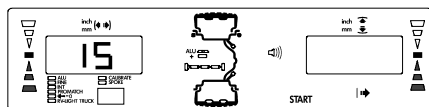

55

- Swing the gauge arm out towards the rim and press the weight firmly against the rim using the ejector (**Fig. 52, item 5**).
- Swing the gauge arm in and return it to its home position.
- Firmly press the adhesive weight on the rim by hand.

8.2.3 How to fit adhesive weights based on given dimensions

If the correction positions are not accessible with the gauge arm and the rim dimensions have been entered using the function keys and rotating the wheel:

- Fit adhesive weights in the given positions according to the balancing mode. Make sure to observe the given positioning dimensions (**Fig. 53**).

8.3 Check run

- When the balance weights are fitted start a check run.

On completion of the check run when the wheel is perfectly balanced, both digital displays show 0 and the OK indicators come up (**Fig. 54**).

Note

If both amount readings are 0, but there is no OK reading, dynamic unbalances below the tolerance limit (suppression preset to 1/4 ounce) add to a static unbalance above the tolerance limit. These residual unbalances are read out upon operation of the FINE key (Fig. 11b, item 11) and should then be balanced.

8.4 Static unbalance

- To display static unbalance press the key to select the display of static unbalance (S/D key; Fig. 11a, item 10). The amount of unbalance is then read out at the left digital display. The direction to be indexed and the correction position are indicated by both direction indicators (**Fig. 55**).

For correction diameter and possibilities of correction of static unbalance see **Fig. 56**.

Balancing the wheel

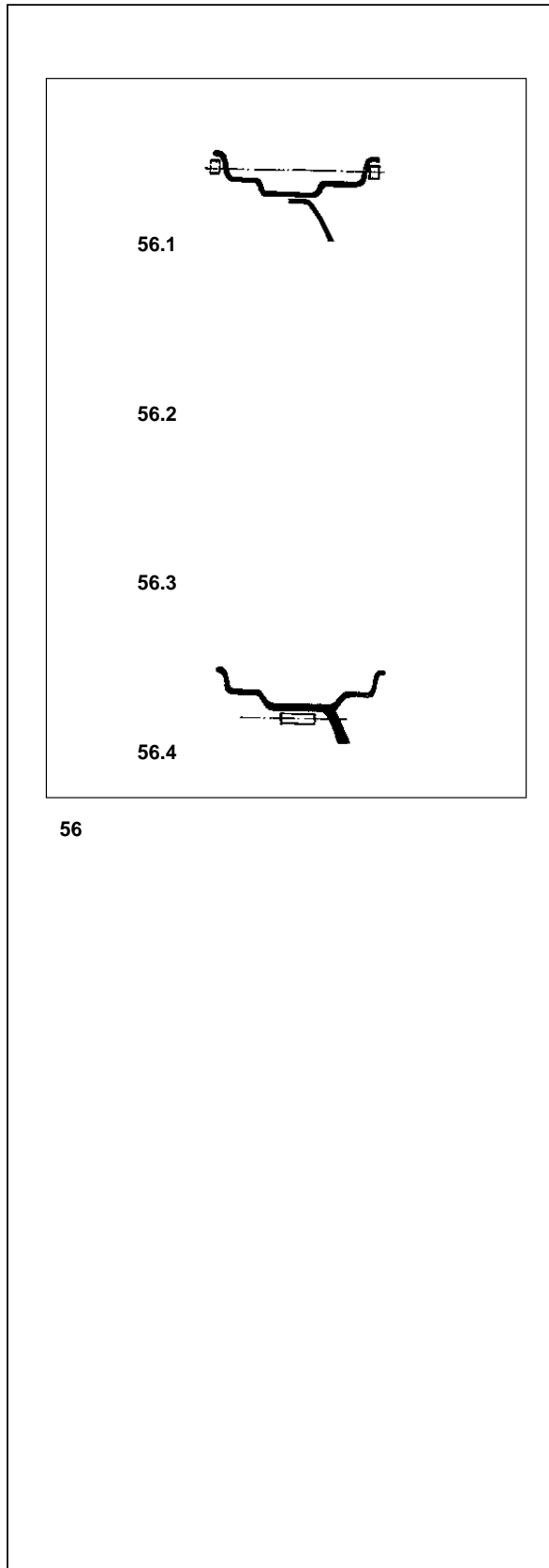

56

Recommendations for fitting balance weights for static unbalance correction

- With large static unbalance (e.g. 1 ounce) divide the unbalance into two equal parts (**Fig. 56.1**).
- With small static unbalance fit the balance weight either in the outer or inner correction plane (**Fig. 56.2 and 56.3**).

Note

Figures 56.1 - 56.3 illustrate how hammer-on weights can be fitted. When adhesive weights are used, or both types are mixed:

- For balancing modes Alu 2 and Alu 3 fit a balance weight in hidden position inside the rim; in this case the correction diameter for static unbalance correction lies inside the rim (**Fig. 56.4**).

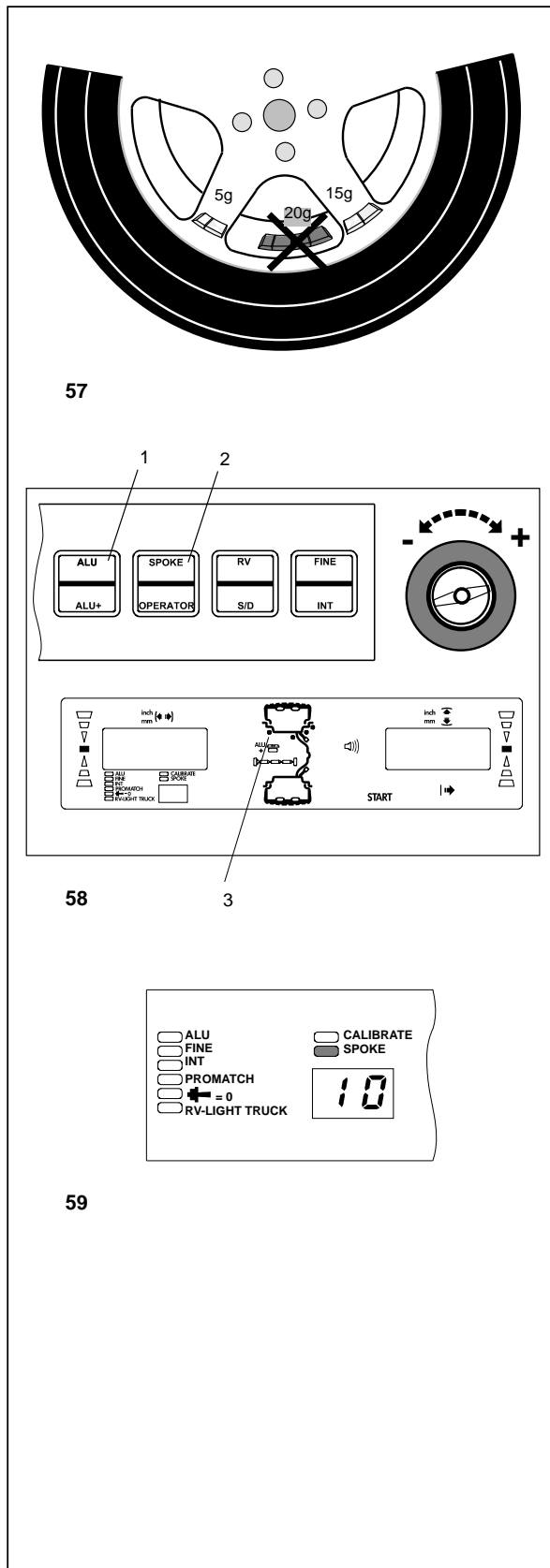

9. Hidden spoke placement

When spoked wheels are balanced, the hidden spoke placement mode allows balance weights which would have to be attached between two spokes according to the measured unbalance to be placed in hidden position behind two spokes adjacent to the unbalance location (see example, **Fig. 57**).

After a measuring run the electronic unit automatically calculates the positions behind the spokes and reads the balance weight locations on the display panel.

The operating steps for the hidden spoke placement mode are described and illustrated below.

9.1 How to proceed

Hidden spoke placement is activated automatically in Alu 2, Alu 2P and Alu 3, Alu 3P balancing modes.

9.2 Choice of balancing mode, choice of hidden spoke placement mode and input of wheel data

- Press and hold the ALU key or the ALU+ key (**Fig. 58, item 1**) and rotate the wheel to set balancing mode Alu 2, Alu 2P, Alu 3 and Alu 3P (weight positions - **Fig. 58, item 3**).
- Press and hold the SPOKE key (**Fig. 58, item 2**) on top and rotate the wheel to set, or change, the number of spokes.

The spoke LED lights up and the number of spokes is displayed (**Fig. 59**). The number of spokes can be chosen between 3 and 12.

Hidden spoke placement

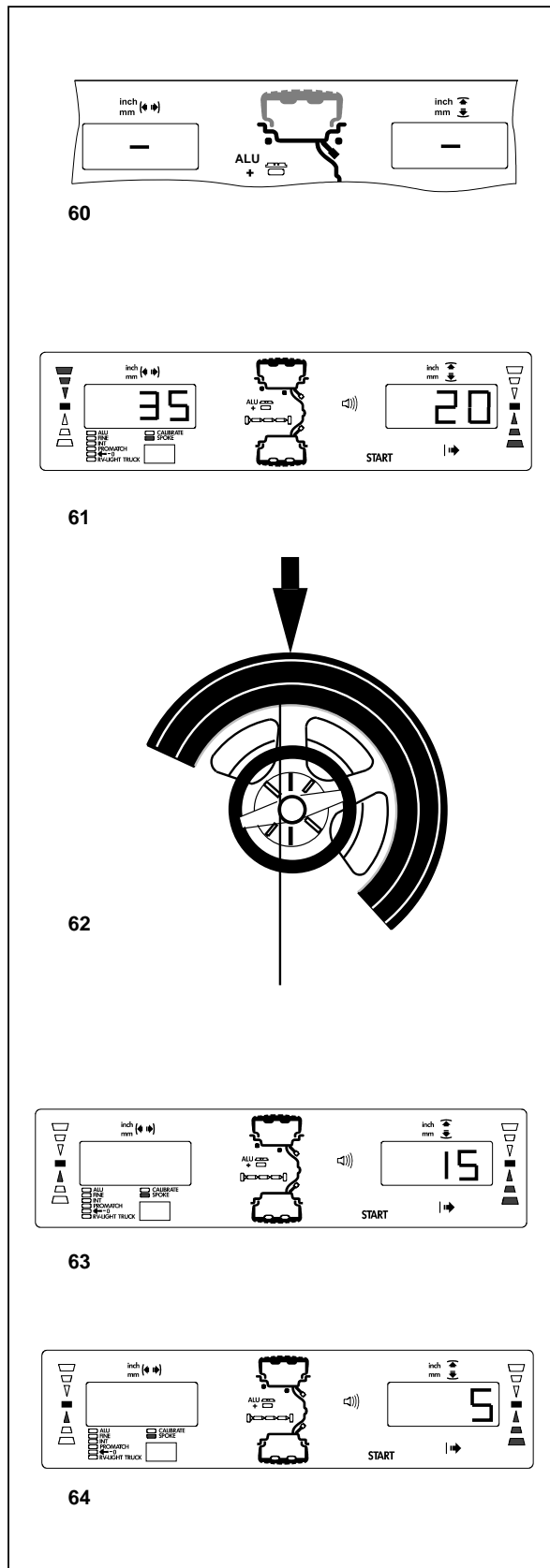

9.3 Correction of measured unbalance

- Press the START key.
The measuring run is carried out.

During measurement one middle segment is read out on each of the digital displays (**Fig. 60**).

After measurement the machine stops automatically, the wheel is braked down to standstill and the display is as shown in **Fig. 61**.

This shows the unbalance measured in each correction plane and the direction towards the correction position on the direction indicator.

How to fit adhesive weights on the left side of the rim disc

- Clean the wheel before attaching the adhesive weights.
- Fit adhesive weights on the left side of the rim as described in § 8.2.

How to fit a hidden adhesive weight

- Rotate the wheel so that a spoke is at 12:00 o'clock (**Fig. 62, arrow**).
- In this position press the key for balancing mode (Fig. 58, item 1).

The divided amount of unbalance of the behind-the-spokes placement is read out for the first adhesive weight in the right correction plane (**Fig. 63**); in the example 15 g.

Note

The small arrow on the left-hand side in **Fig. 63** indicates the shortest way to index the position of the other adhesive weight.

- Index the wheel to the exact position for correction in the first correction position and hold the wheel in this position with the main shaft lock.
- Clean the wheel before attaching the adhesive weights.
- Attach a weight in the position (in the example 15 g, **Fig. 63**).
The divided amount of unbalance of the behind-the-spokes placement is read out for the second adhesive weight in the right correction plane (**Fig. 64**); in the example 5 g.
- Fit the second weight behind the spoke in the same way.

To return to the undivided reading of unbalance for left and right correction plane (Fig. 61):

- Briefly press the key for balancing mode (Fig. 58, item 1). The unbalances for left and right correction plane are read out. The behind-the-spokes placement mode is still active as long as Alu 2, Alu 2P, Alu 3 or Alu 3P are set.

To leave the behind-the-spokes placement mode and reset the electronic unit to the conventional balancing mode:

- Press and hold the key for balancing mode. Rotate the wheel to set a balancing mode other than Alu 2, Alu 2P or Alu 3, Alu 3P.

or

- In the reading "Wheel data" press twice the key for balancing mode and set number of spokes to 0.

10. Changing modes of operation

Inputs and readings when a mode of operation is changed (Fig. 65 - example code C2)

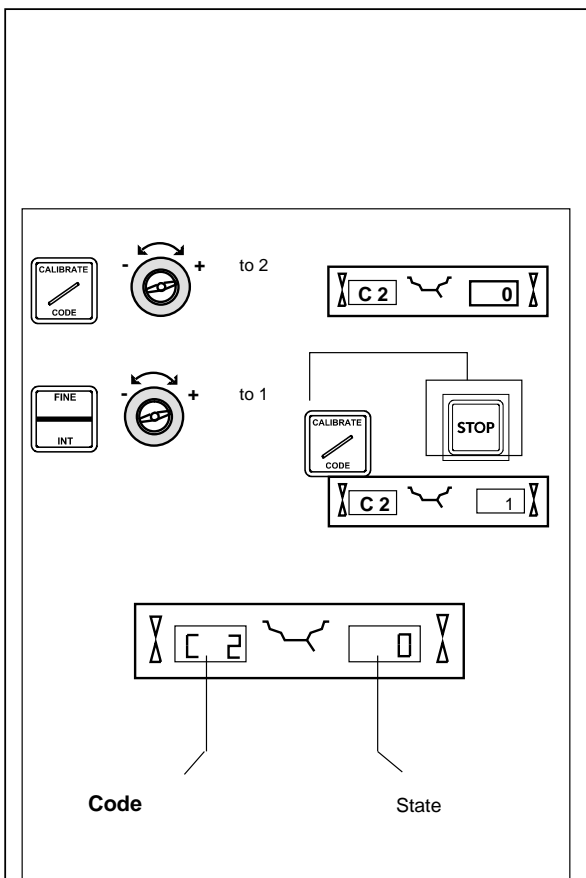

65

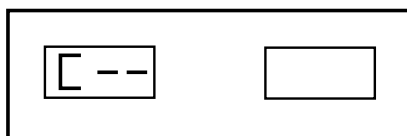

66

- Press and hold the CODE key. The C code that was last set is displayed.
- Rotate the wheel to set the desired code (e. g. 2) in the display.
- Release the CODE key when the desired code is read out.

C and code number 2 are read out in the left digital display.

The right digital display shows the present state of this code, e. g. 0 for switched off.

If the desired state is already read out:

- Press the CODE key to return to the basic reading (Fig. 66), or abort by pressing STOP.

If the desired state has to be set:

- Press and hold the FINE key. Rotate the wheel to set the desired state (e. g. 1) in the display. For some codes a given value can be set.
- Release the FINE key when the desired code or value is read out.
- Press the CODE key to acknowledge the input and to return to the basic reading (Fig. 66), or abort by pressing STOP.

Quit the C code or abort and return to normal working mode:

- Press the STOP key.

Having completed the input of mode of operation it will remain stored until the machine is switched off with the main switch, or until a new input is made.

The changed modes can also be stored permanently with code C10, so that they are not cancelled when the machine is switched off but are retained in a permanent memory for future use until a new input is made and stored. Code C4 Compensation of clamping means cannot be stored in the permanent memory.

The possible changes of codes and the necessary inputs are described in the following.

Changing modes of operation

Input: Code/state Display: Code/state

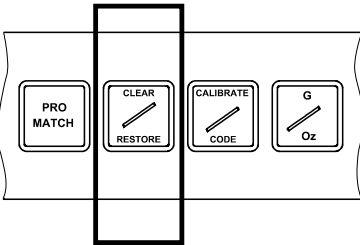

67

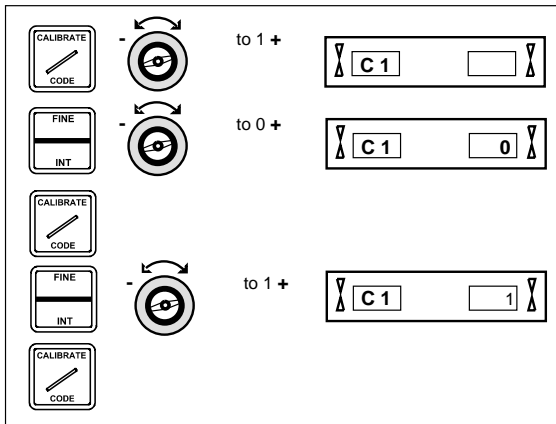

68

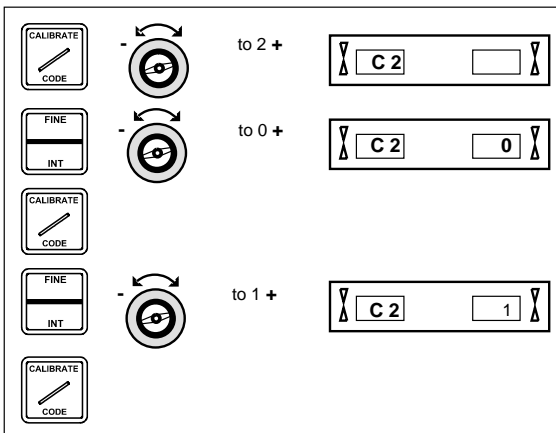

69

Code C0

Fig. 67 Setting the factory-adjusted modes of operation (see § 5.)

CLEAR (key pressed briefly): Setting the factory adjusted modes of operation. All settings are deleted and the display returns to standard.

RESTORE (key pressed for 3 seconds): Restores all modes the way they were before clear was pressed (provided they were stored previously).

Code C1

Fig. 68 Selecting the resolution of unbalance readings in 1 or 5 g, or 0.05 or 0.25 oz increments

0* = 5 g (0.25 oz) increments 1

= 1 g (0.05 oz) increments

The selected mode of operation can be transferred to the permanent memory.

Code C2

Fig. 69 Selecting suppression of minor unbalance readings

0 = Suppression off 1*

= Suppression on

The selected mode of operation can be transferred to the permanent memory.

* = Factory adjusted mode

Input: Code/state Display: Code/state

70

71

72

Code C3

Fig. 70 Selecting unbalance readings in grams or ounces, active when the machine is switched on

0 = Readings in grams 1* =

Readings in ounces

The selected mode of operation can be transferred to the permanent memory.

Code C4

Fig. 71 Electrical compensation of residual unbalance in the wheel adapter

Measurement with increased precision (this mode cannot be transferred into the permanent memory).

Compensation has to be cancelled and carried out once again when the wheel adapter is exchanged.

Resetting the status to 0 cancels the compensation of adapter unbalance.

The compensation is cancelled by calibration, or readjustment of the machine, by Pro-Match, or when the machine is turned off.

0 = Carry out compensation

1 = Compensation completed

0 = Compensation after the measuring run switched off again

Code C5

Fig. 72 Braking of the wheel when the (optional) wheel guard is opened during the measuring run.

If the mode is set to "0", the wheel rotates when the wheel guard (option) is open.



Caution! Rotating wheel may swing away objects and draw in clothes.

Injuries are possible.

- Wear safety goggles and tightly fitting working clothes.
- Make sure that the wheel is not blocked by tools or the like.

0 = No braking

1* = Braking

The selected mode of operation can be transferred to the permanent memory.

* = Factory adjusted mode

Changing modes of operation

Input: Code/state Display: Code/state

73

74

75

Code C6

Fig. 73 Number of revolutions per measuring run
5 to 25 revolutions possible,
factory-set to 10*

Example: change to 7 revolutions per measuring run

Note

Reducing the number of measurement revolutions will reduce the accuracy of measurement. The selected mode of operation can be transferred to the permanent memory.

Code C7

Fig. 74 Volume of audible signals Scale of
volume 0 to 100 (low - high), factory-
adjusted to 50*

Example: set volume to 60

The volume is not changed before the CODE key is pressed for quitting the mode.

The selected mode of operation can be transferred to the permanent memory.

Code C8

Fig. 75 Selecting the limit (threshold) value for suppression of
minor unbalance readings in grams, or ounces. The
unit (gms or oz) depends on the settings made
under C3.

Grams:

Range 3.50 to 20.0 g

Factory-adjusted to 3.5 g

Read out limit, e. g. 3.50 g

Select another limit, e. g. 5.50 g

Ounces:

Range 0.25 to 2.00 oz

Factory-adjusted to 0.25 oz

Read out limit, e. g. 0.25 oz

Select another limit, e. g. 0.50 oz

The selected mode of operation can be transferred to the permanent memory.

* = Factory adjusted mode

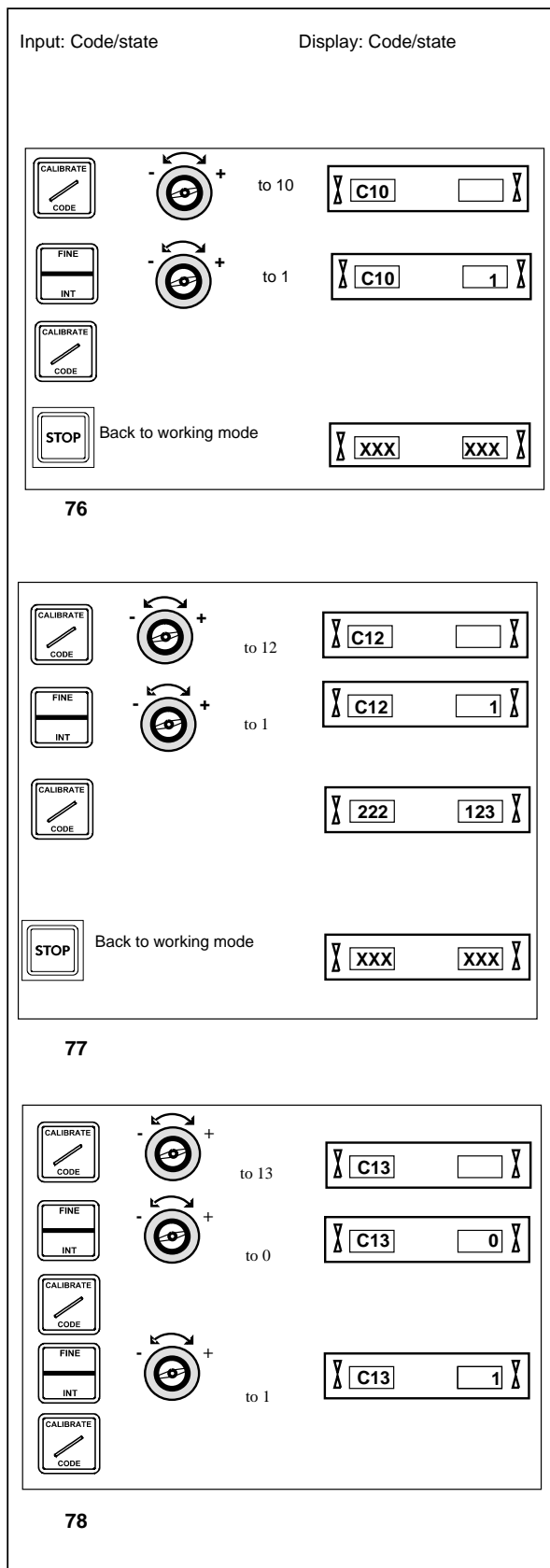

Code C10

Fig. 76 Storing the selected modes of operation in the permanent memory

0* = No storage

1 = Data are stored in the permanent memory

- Store in the permanent memory - a three-tone signal is given to acknowledge acceptance.

If the mode stored in the permanent memory is to be changed, enter the desired state (e. g. on or off) for the mode in question and transfer it via code C10 into the permanent memory (not possible for code C4).

Code C12

Fig. 77 Readings of numbers of measuring runs

Example: 222,123 measuring runs so far performed By pressing the FINE key an turning the wheel the following counters can be displayed:

- 1 = Total number of measuring runs
- 2 = Number of measuring runs where balance quality was considered OK
- 3 = Number of Pro-Matches performed
- 4 = Number of measuring runs in service mode
- 5 = Number of measuring runs since the last calibration

Maximum count is 999,999 runs. Once this number is reached, the counter is reset to zero.

Code C13

Fig. 78 Starting the measuring run by closing of (optional) wheel guard

0* = Start via START key 1

= Start via wheel guard

The selected mode of operation can be transferred to the permanent memory.

* = Factory adjusted mode

Changing modes of operation

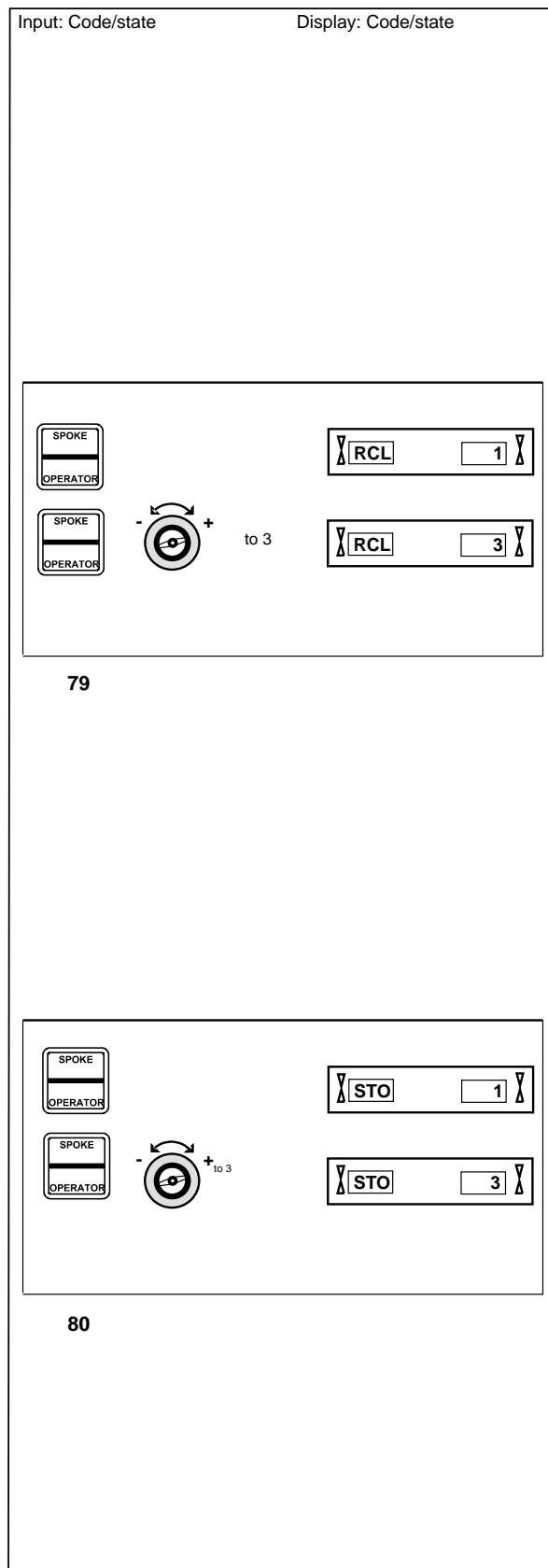

Code C14

Readjustment of the machine by the operator

See § 13. User calibration.

Code C17

Fig. 79 Select previously stored wheel profile

Load a previously stored wheel profile. This replaces the previously valid settings.

- Keep the OPERATOR key pressed on bottom. RCL (recall) comes up in the left-hand section of the display and 1 comes up in the right-hand section for the first wheel profile to be loaded.
- Keep the key pressed on bottom and rotate the wheel. Profiles 2 through 4 are read out in the right-hand display. The stored wheel profile (e. g. 3) is entered once the key is released.

The following information is available (if applicable):

- Nominal wheel dimensions
- Values measured with the gauge arm
- Weight positions
- Positions for relocation See also

C18

Code C18

Fig. 80 Store wheel profile

- If a wheel profile is to be stored, keep on pressing the OPERATOR key after the RCL readings have come up and continue rotating the wheel. Now STO (store) comes up in the left-hand display, and No. 1 through 4 can be set in the right-hand display by rotating the wheel. The current profile is stored once the key is released.

It is possible to store up to 4 wheel profiles.

The following values (if available) are stored:

- Nominal wheel dimensions
- Values measured with the gauge arm
- Weight positions
- Positions for relocation

See also C17

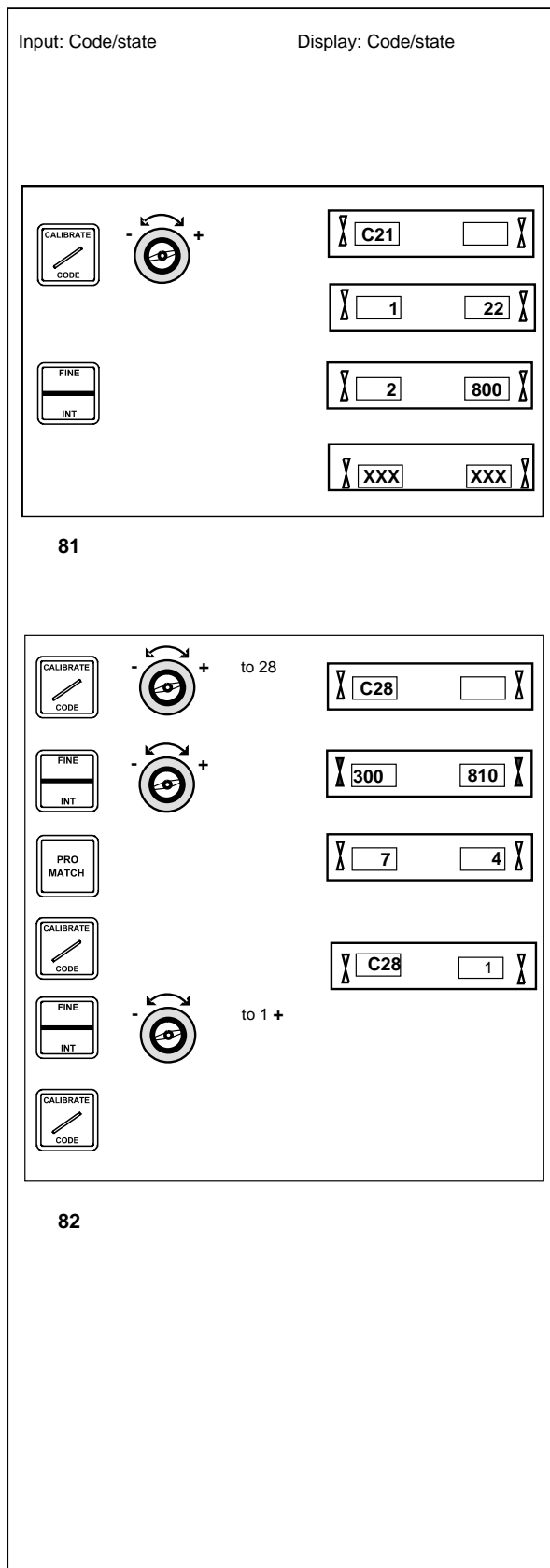

Code C21

Fig. 81 Display of spell program version and model number

Example: Spell program version 1.22 for 2800

- Release CODE key to display program version.
- Press on FINE key to display model number.

Code C28

Fig. 82 Select one of the 10 stored error codes and clear the error memory

The last 10 different error codes are written to the error memory so that they can be called up and reported by the operator of the wheel balancer, e.g. for remote diagnosis of malfunctions. The most recent error code is written to memory location 1 and the previous error codes are shifted to the higher memory locations.

- Select one of the 10 malfunction code messages.
- Press the PRO MATCH key to display the memory location (left) and number of incidents (right), e.g. error code on memory location 7 occurred 4 times
- Press the CODE key for the 2nd step.
- Press and hold FINE key and rotate the wheel to set the desired state:
 0 = Do not clear the error memory
 1 = Clear error memory

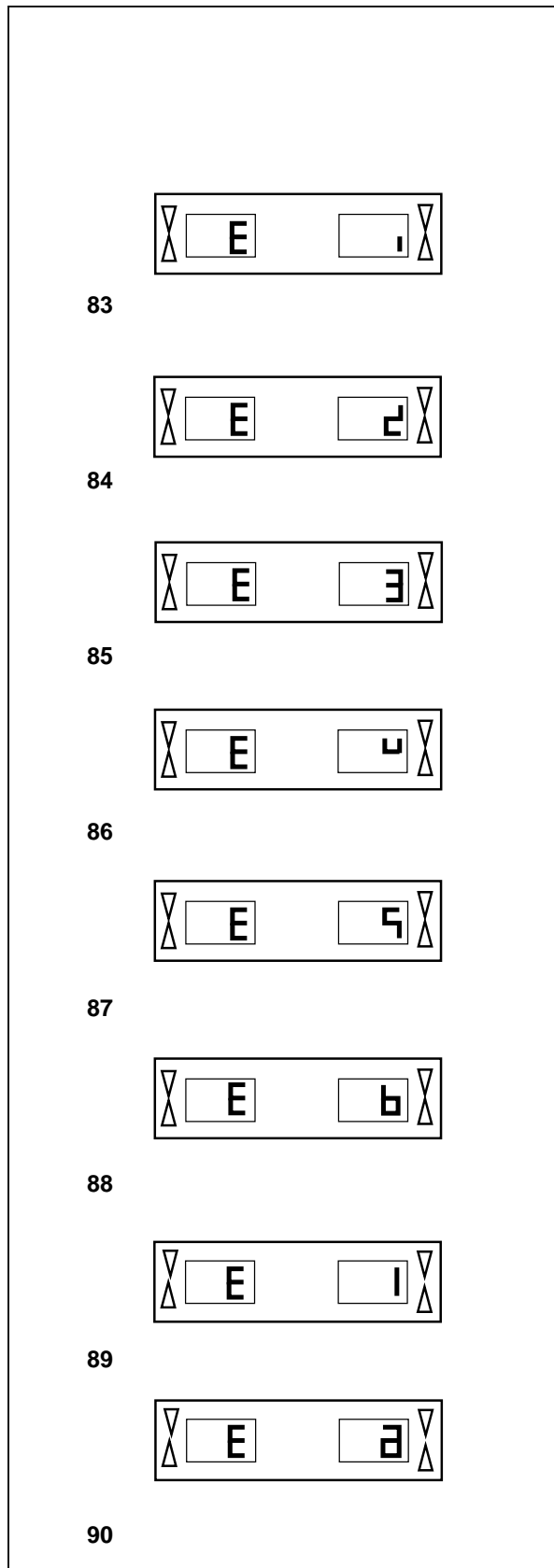

11. Error codes

Errors in operation	-	Error code E
Warnings	-	Error code H
Fatal error code	-	300 or C10

E1 - Fig. 83

Rim dimensions were entered incorrectly, or incompletely.

- When the error code is read out, enter data once again.

E2 - Fig. 84

Wheel guard is not closed.

E3 - Fig. 85

Gauge arm for distance and rim diameter is not in home position.

E4 - Fig. 86

Width gauge arm is not in home position.

- Move gauge arm to its home position. Press the STOP key or the ESC key to continue.

E5 - Fig. 87

Range of electrical compensation exceeded (wheel adapter has unacceptable unbalance).

- Press STOP key.
- Check wheel adapter, repeat compensation run.

E6 - Fig. 88

The calibration weight was not attached for readjustment.

- Press STOP key.
- Repeat readjustment.

E7 - Fig. 89

With this wheel type it is not possible to choose a balancing mode.

E8 - Fig. 90

Valve position was not entered (error code only in Pro-Match program).

- Position valve at 12:00 o'clock and press the PRO MATCH key.

91



92



93

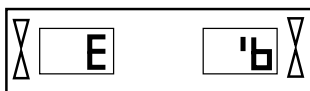

94

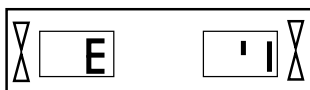

E9 - Fig. 91

Pro-Match/minimisation was carried out incorrectly.

1. Wheel was not exactly centered on the wheel adapter during every run.
2. Tire was mounted eccentrically on the rim for at least one time.
3. Valve position was incorrectly indexed for at least one time and entered incorrectly.
4. Wrong mark (single or double mark) was used for reference when readjusting the tire.
5. Wheel got out of place on the wheel adapter during the measuring run.
6. Wrong wheel dimensions were entered.
 - Repeat the Pro-Match procedure.

E15 - Fig. 92

Readjustment is out of range.

During readjustment values were determined which exceed, or fall below, the adjustment value.

- Press the CODE key to transfer the corrective terms into the permanent memory.
- Call for the service technician to readjust the machine.

E16 - Fig. 93

During the first readjustment run by the operator the calibration weight was attached by mistake.

- Unscrew the calibration weight and start the measuring run again.

E17 - Fig. 94

Wheel slips on the wheel adapter.

The clamping nut is not tight, the main shaft accelerates too quickly. The machine will stop.

- Firmly tighten the clamping nut, or if the wheel is very small press the START key a little bit longer.

Error codes

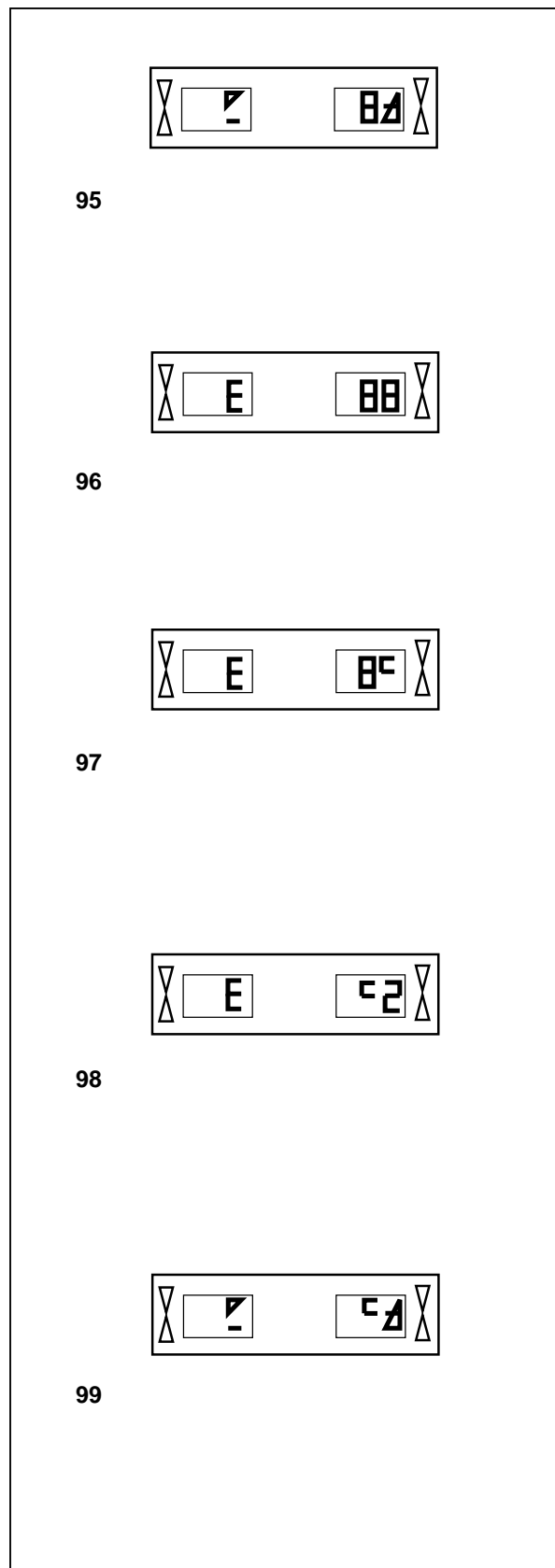

E83 - Fig. 95

During a measuring run the measured data have been unusable because of the effect of outside vibrations.

- Make sure the machine is on a solid floor and repeat the measuring run again.

E88 - Fig. 96

The rotating speed of the main shaft exceeds the limit.

E89 - Fig. 97

A key is stuck at power-on.

- Find and release the key, or call service.

E92 - Fig. 98

Gauge arm defective.

- Call service.
- As long as the gauge arm is defective, enter by pressing the distance key and rotating the wheel (§ 7.2.3).

E93 - Fig.

During the second attempt the width gauge arm was still not in the home position. The gauge arm is rendered inoperative.

- Wait 3 seconds, or press the STOP key or the ESC key.

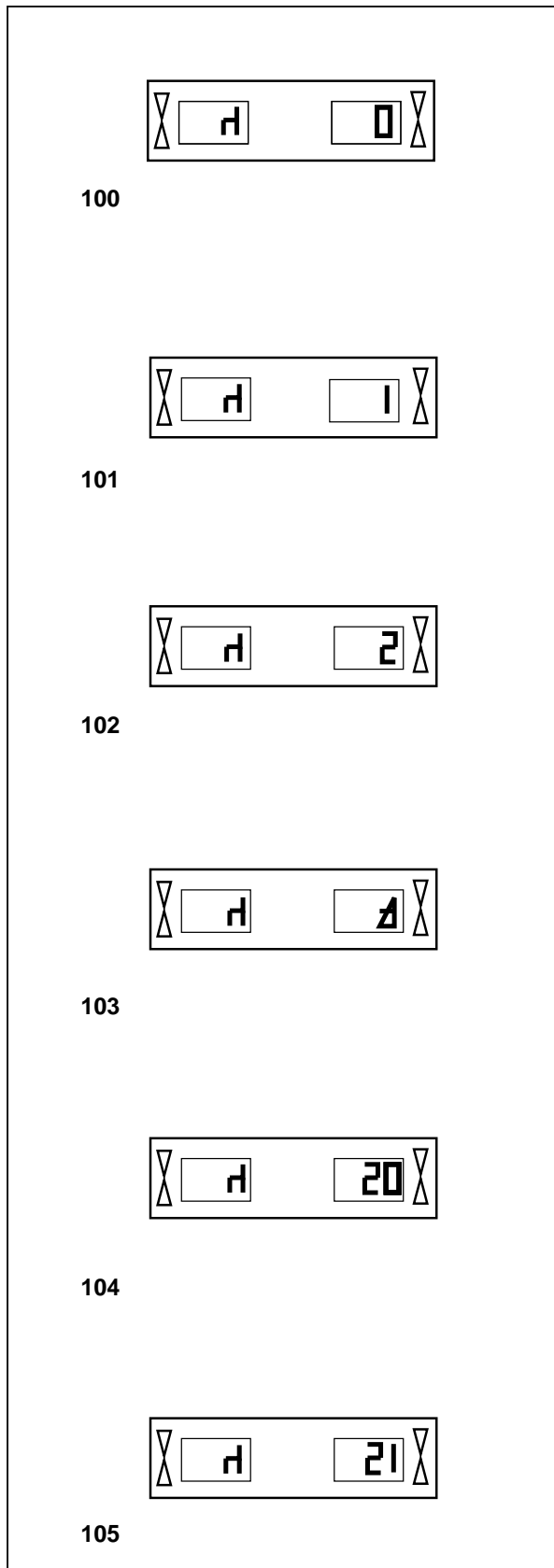

H0 - Fig. 100

Wheel running conditions cannot be improved by Pro-Match.

H1 - Fig. 101

Further Pro-Match not recommended but feasible.

H2 - Fig. 102

Weight minimisation is recommended, Pro-Match can achieve no further improvement.

H3 - Fig. 103

Pro-Match not recommended.

H20 - Fig. 104

Correction plane cannot be re-located with the gauge arm.

- Measure the correction plane and switch to dynamic unbalance reading.

H21 - Fig. 105

The indexed position is not the one for the correction plane in which the adhesive weight is to be fitted with the gauge arm.

- Index the correct position for this correction plane prior to attaching the adhesive weight.

Error codes

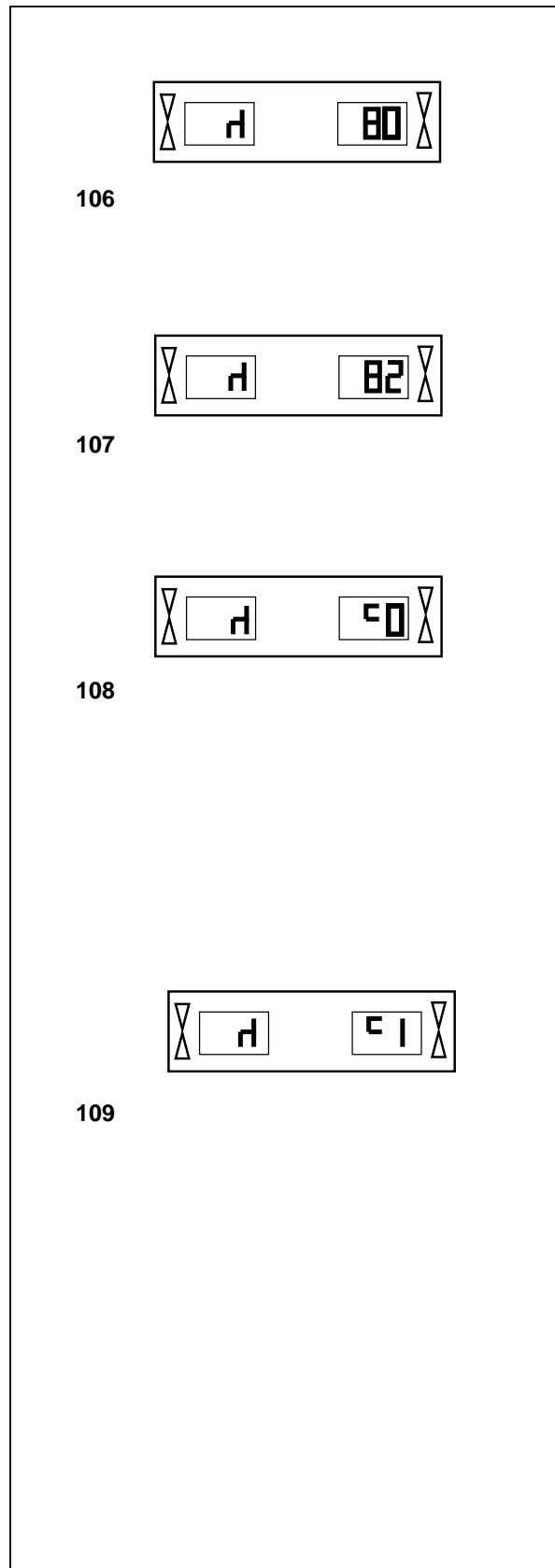

H80 - Fig. 106

Readjustment feature not stored in the computer or lost from memory. Consequently user calibration is not possible.

- Press on STOP key, error code is deleted.
- Call service for calibration of the machine.

H82 - Fig. 107

The self-test was disturbed (e.g. by rotating the wheel).

- The message is displayed for 3 seconds, after which the measurement is repeated (max. 10 times), or aborted by pressing the STOP key.

H90 - Fig. 108

The wheel was accelerated too slowly or decelerated too slowly after a measuring run.

If the main shaft does not reach the required speed, check whether the shaft with mounted wheel can not rotate freely or whether the weight of the wheel is excessive. In this case:

- Make sure that the shaft with mounted wheel can rotate freely.
- Turn the wheel by hand and then press on START key.
- If the error cannot be remedied: call service.

H91 - Fig. 109

Speed variations during measuring run.

- Make sure that the shaft with mounted wheel can rotate freely.
- Repeat the measuring run.

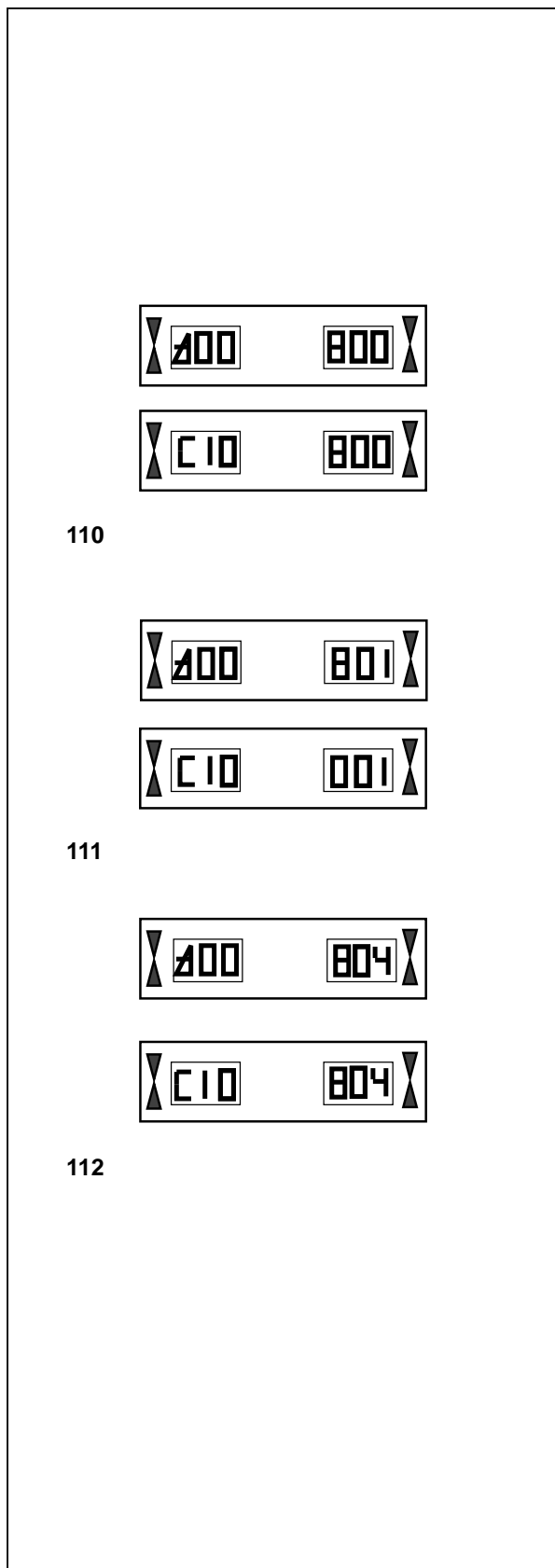

Fatal error codes

The display shows an alphanumeric code consisting of six digits and/or letters. When messages are read out starting 300XXX the error occurred during the internal operational check, if it is C10XXX it occurred during the self-test after the machine was switched on.

- If necessary, call service.

Note

The displayed error codes refer only to the internal line voltage of the machine.

300 800 or C10 800 - Fig. 110

Line voltage too low. Balancing is feasible if the motor can drive the main shaft to the measuring speed. Wheel data may be lost.

- Bring the line voltage to within a range of 115 - 120 V AC.

300 801 or C10 801 - Fig. 111

Line voltage too high. Damage to the electronic unit of the machine is likely!

- **Turn off machine immediately.**

Damage is not covered under warranty.

300 804 or C10 804 - Fig. 112

Line voltage too high. Damage to the electronic unit of the machine is likely!

- **Turn off machine immediately.**

Damage is not covered under warranty.

Error messages by means of acoustic signals

Error messages can also be indicated by means of acoustic signals. The service technician can locate and eliminate the corresponding error by means of the number of tones, their frequency and duration (long/short) and the length of the pauses.

- Switch off the machine.
- Call service.



12. Pro-Match/Weight minimisation

12.1 General

Pro-Match, the optimisation program, is an improvement of the matching procedure.

Tire and rim are adjusted on the basis of unbalance test results. This produces reduction of lateral and radial run-out and of radial and lateral force variation, as well as reduction of balance weight size.

If Pro-Match is not desired, it is possible to achieve weight minimisation.

This is possible when there is no deformation of the rim, but where unsmooth ride is only due to non-uniform mass distribution in the tire. In this case the unbalance present in the rim can be adjusted relative to the unbalance present in the tire so that the unbalances compensate for each other and the smallest possible balance weight can be determined.

12.2 General instructions for the Pro-Match/weight minimisation programs

It may be necessary to interrupt the Pro-Match/minimisation program by pressing the STOP key. The electronic unit will store the current program step, the rim dimensions and all measurements taken so far.

To continue with the Pro-Match/minimisation program, press the OP and CODE keys in succession. The program then continues at the step where it was interrupted, using the initial data inputs and measured data.

If a measuring run is interrupted by operation of the STOP key the machine will switch back to the previous program step. Pro-Match/minimisation is then continued by entering the valve position of the wheel with the PRO MATCH key.

After interruption by operation of the STOP key the readings refer to the unbalance of the latest measuring run.

To start the Pro-Match/minimisation program anew after an interruption, it is only necessary to press the PRO MATCH key.

During Pro-Match/minimisation a measuring run always has to be started with the START key.

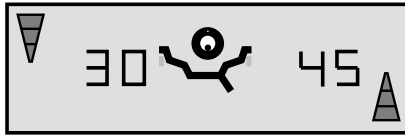

113

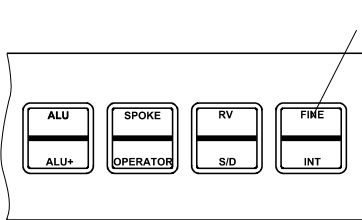
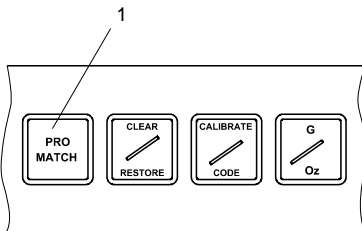

114

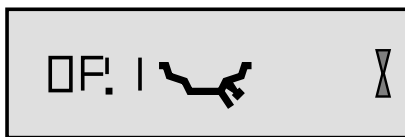

115



116

12.3 Pro-Match program

The sequence of operations for the Pro-Match program and for the minimisation program (code Un) is described below, with the possible readings illustrated in the figures.

Pro-Match

Use of Pro-Match is recommended automatically after a measuring run by viewing the OP symbol if the unbalance in left and/or right correction planes and/or static unbalance is greater than 1 ounce (**Fig. 113**).

- Demount the tire and clamp the rim.
- Depress the PRO MATCH key (**Fig. 114, item 1**).

Reading OP.1 (**Fig. 115**) comes up.

Note that after all readings in which the valve symbol is shown at the rim contour the PRO MATCH key must be pressed to enter the valve position (with the tire valve positioned at 12:00 o'clock) after the tire has been displaced on the rim.

- Rotate the tire so that the valve stem is set at 12:00 o'clock.
- Depress the PRO MATCH key (**Fig. 114, item 1**) to enter the valve position.

Reading OP.2 (**Fig. 116**) comes up.

An incorrect valve position input can be corrected by repeating this step.

Weight minimisation

If no Pro-Match, but only weight minimisation (i.e. without compensation with the rim only) is desired, proceed as follows:

- Clamp the tire/rim assembly.
- Depress the PRO MATCH key (**Fig. 114, item 1**).

Reading OP.1 - **Fig. 115** comes up.

- Depress the FINE key (**Fig. 114, item 2**) to switch over to the minimisation program.

The reading goes to Un.3 (see § 12.4, Fig. 126) where you proceed with the program.

- At level OP.2 the compensation run can still be omitted. Again, proceed with the program by depressing the FINE key.

As a result the reading goes to Un.4 (see § 12.4, Fig. 127) where you continue.

The valve position input of OP.1 remains entered.

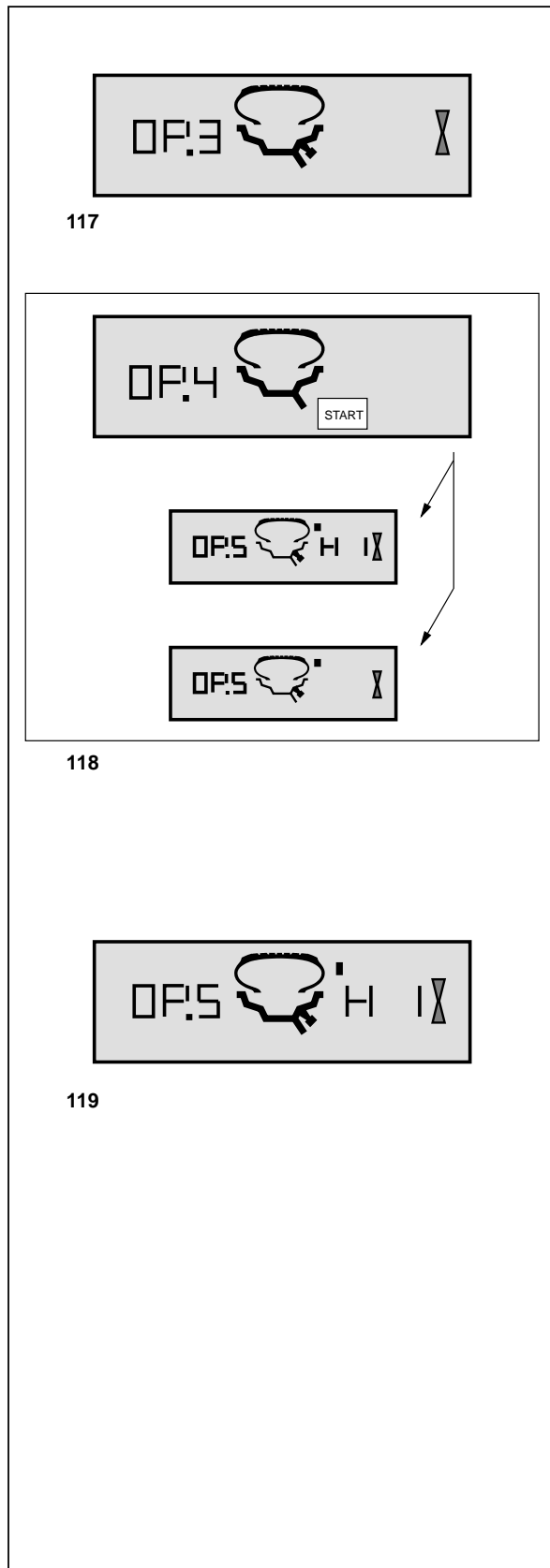

How to continue the Pro-Match program

- Press the START key (Fig. 116) to start the compensation run of rim without tire.

After the measuring run the reading is OP.3 (Fig. 117).

- Mount the tire and inflate.

Note

For mounting, demounting, readjustment or turning over of the tire on the rim always apply a sufficient quantity of tire lubricant on tire beads, rim flanges and bead seats. Each time the tire has been readjusted relative to the rim, inflate tire according to the tire manufactures recommendation. Make sure the mounting guide rib of the tire is correctly seated.

- Clamp the tire/rim assembly on the balancer.
- Readjust such that the valve is set at 12:00 o'clock.
- Press the PRO MATCH key to enter the valve position.

Reading OP.4 (Fig. 118) comes up.

- Press the START key.

The measuring run is carried out. After the measuring run two readings are possible:

OP.5 - H 1 (see Fig. 119)

Further Pro-Match is not recommended, but possible.

OP.5 - reference mark (see Fig. 120)

Continue with the Pro-Match program.

Reading OP.5 - H 1 (Fig. 119)

If OP.5 - H 1 is read out further Pro-Match is not recommended. In this case the measured data does not exceed the limit for recommendation of the Pro-Match program. However, it is possible to continue Pro-Match so as to improve wheel running conditions even below the limit value.

To continue Pro-Match:

- Proceed as specified for reading OP.5 - reference mark (see Fig. 119).

To abort Pro-Match:

- Press the STOP key to return to the balancing program and balance the wheel according to the readings.

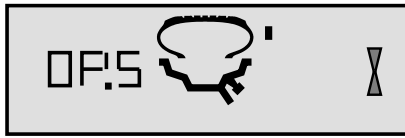

120

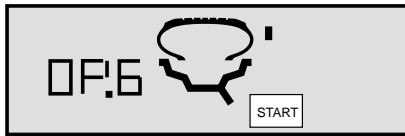

121

Reading OP.5 - reference mark (Fig. 120)

- After the measuring run index the wheel following the position reading and provide a crayon mark on the right side of the tire at 12:00 o'clock.
- Readjust the tire on the rim such that the tire mark coincides with the valve.
- Clamp the tire/rim assembly on the balancer and rotate the valve stem at 12:00 o'clock.
- Press the PRO MATCH key to enter the valve position.

Reading OP.6 (Fig. 121) comes up.

- Press the START key.

After the measuring run four readings are possible:

=== - OP.7 (see Fig. 122)

Proceed with the OP program. It is recommended that the tire be turned over on the rim.

OP.7 - === (see Fig. 123)

Proceed with the OP program. It is recommended that the tire be readjusted on the rim.

H 0 (see Fig. 124)

Optimum condition has been achieved and cannot be improved.

H 2 (see Fig. 125)

Wheel running conditions cannot be improved. However, it is possible to readjust the tire relative to the rim to obtain a minimisation of balance weights without having an adverse effect on wheel running conditions.

Depending on the readings, there are several possibilities for proceeding with the program. These possibilities are described below.

Pro-Match/Weight minimisation

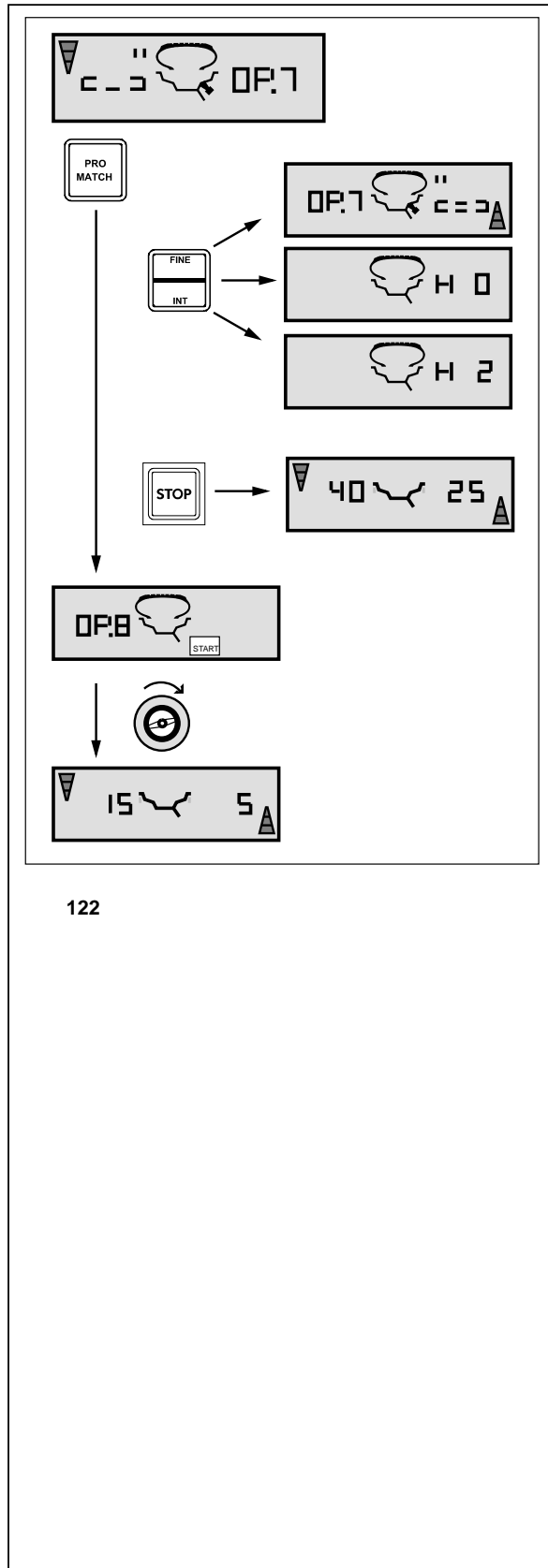

Reading === - OP.7 (Fig. 122)

Recommendation to turn tire over on the rim (the left display segments are rotating).

Choice 1 Turn tire over on the rim (standard program)

- Index the wheel to 12:00 o'clock following the **left** direction indicator and provide a double mark on **left** side of the tire.
- Remove the wheel from the machine.
- Turn the tire over on the rim and readjust until the double mark coincides with the valve.
- Clamp the tire/rim assembly on the balancer and rotate the valve stem to 12:00 o'clock.
- Press the PRO MATCH key to enter the valve position.

Reading OP.8 comes up.

- Press the START key (check run).

If the Pro-Match run has been carried out correctly following the above sequence of operations, the balancer will return to the balancing mode selected before Pro-Match and read out the dynamic unbalance still left in the wheel (**Fig. 122**).

- Balance the wheel according to the readings.

Reading of error code E9

If E9 is read out, at least one error was made with respect to the sequence of operations when performing Pro-Match (see § 11. Error codes). Abort the Pro-Match program by pressing the STOP key and, if desired, start Pro-Match once again.

Choice 2: Do **not** turn tire over on the rim

- Press the FINE key.

The result is then converted.

Reading is OP.7 - - - (see Fig. 123) or H0 (see Fig. 124) or H2 (see Fig. 125).

- To return to === - OP.7, press the FINE key once again.

Choice 3: Abort Pro-Match

- Press the STOP key to return from the Pro-Match to the balancing program.

The unbalance present in the wheel is read out.

- Balance the wheel according to the readings.

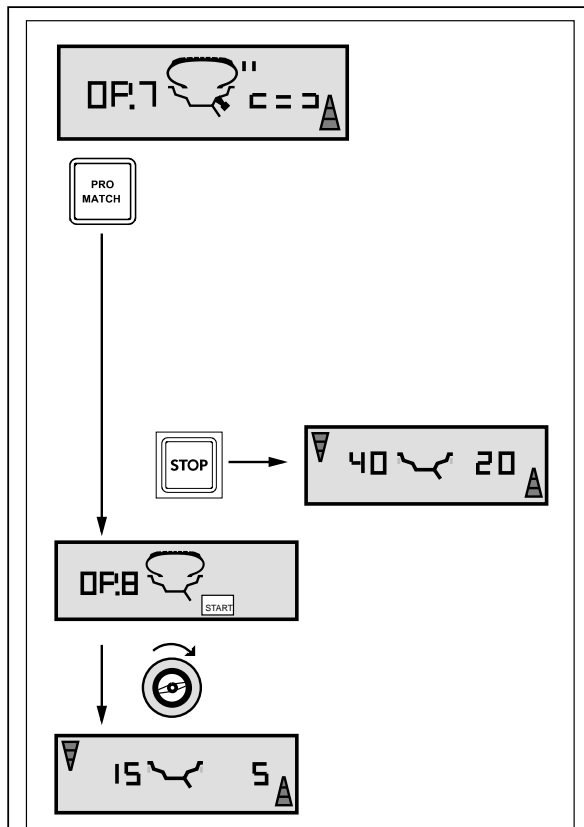

123

Reading OP.7 - === (Fig. 123)

Recommendation to readjust tire on the rim (the right display segments light up permanently).

Choice 1: Readjust tire on the rim (standard program)

- Index the wheel following the **right** direction indicator and provide a double mark on **right** side of the tire at 12:00 o'clock.
- Remove the wheel from the machine.
- Readjust the tire on the rim until the double mark coincides with the valve.
- Clamp the tire/rim assembly on the balancer and readjust at 12:00 o'clock.
- Press the PRO MATCH key to enter the valve position.

Reading OP.8 comes up.

- Press the START key (check run).

If the Pro-Match run has been carried out correctly following the above sequence of operations, the balancer will return to the balancing mode selected before Pro-Match and read out the dynamic unbalance still left in the wheel (**Fig. 123**).

- Balance the wheel according to the readings.

Reading of error code E9

If E9 is read out, at least one error was made with respect to the sequence of operations when performing Pro-Match (see § 11. Error codes). Abort the Pro-Match program by pressing the STOP key and, if desired, start Pro-Match once again.

Choice 2

- Press the STOP key to return from the Pro-Match to the balancing program.

The unbalance present in the wheel is read out.

- Balance the wheel according to the readings.

Pro-Match/Weight minimisation

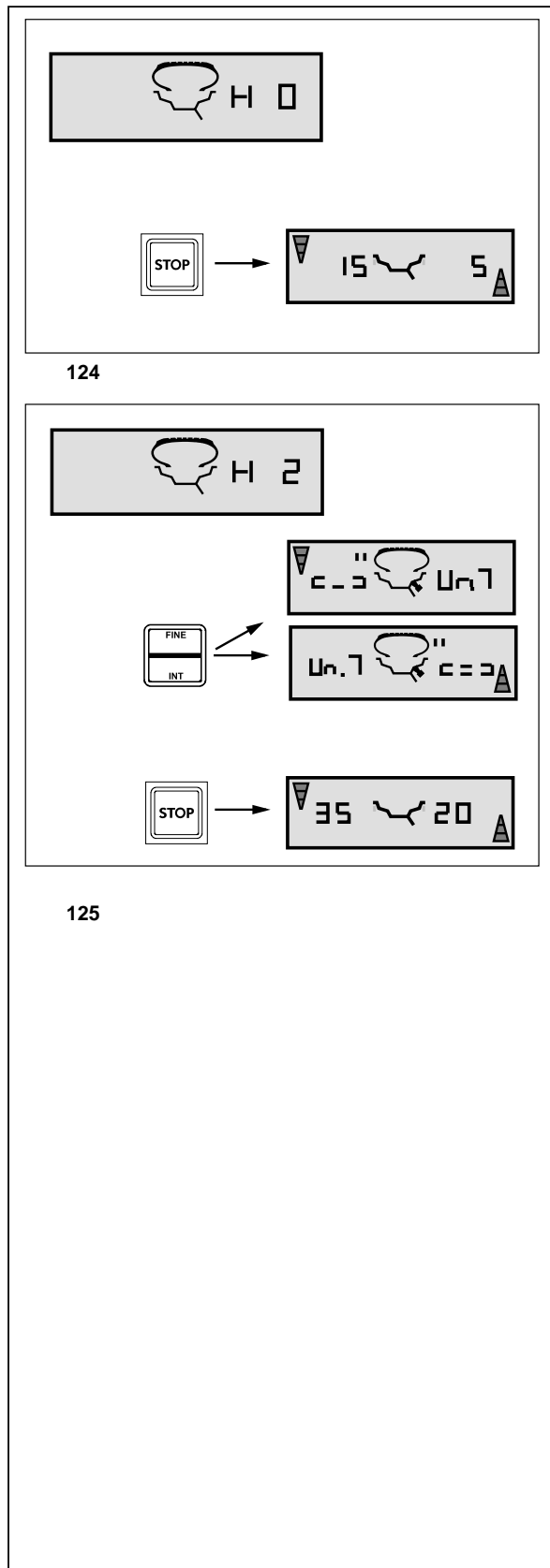

Reading H 0 (Fig. 124)

- Press the STOP key to leave the Pro-Match program and return to the balancing program.

The unbalance present in the wheel is read out.

- Balance the wheel according to the readings.

Optimum condition has been achieved and cannot be improved.

Reading H 2 (Fig. 125)

Wheel running conditions cannot be improved. However, it is possible to achieve weight minimisation.

Choice 1: Continue with weight minimisation

- Press the FINE key to continue in the program.

As a result readings are === - Un.7 (Fig.131) or Un.7 - === (Fig. 132).

Choice 2: Abort Pro-Match

- Press the STOP key to leave the Pro-Match program and return to the balancing program.

The unbalance present in the wheel is read out.

- Balance the wheel according to the readings.



126

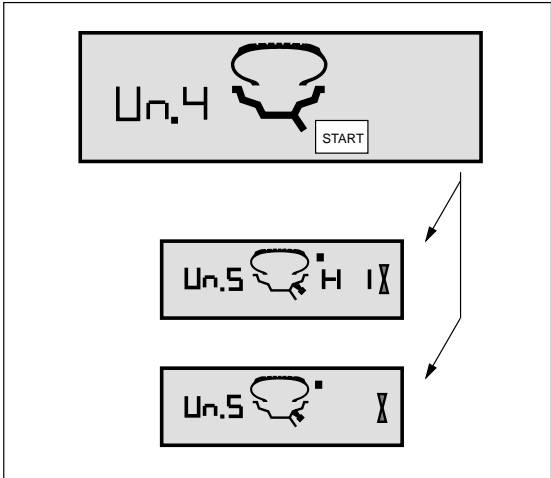

127



128

12.4 Minimisation program

If the compensation run of the rim without tire was omitted and the FINE key was pressed to go directly into the minimisation program (reading Un.3 - Fig. 126), proceed as follows.

- Clamp the tire/rim assembly on the balancer.
- Readjust such that the valve is at 12:00 o'clock.
- Press the PRO MATCH key to enter the valve position.

Reading Un.4 comes up (Fig. 127).

- Press the START key.

The measuring run is carried out. After the measuring run two readings are possible:

Un.5 - H 1 (see Fig. 128)
Further minimisation is not recommended, but possible.

Un.5 - reference mark (see Fig. 129)
Continue with the Un program.

Reading Un.5 - H 1 (Fig. 128)

If Un.5 - H 1 is read out further minimisation is not recommended. In this case, the measured data does not exceed one ounce. However, it is possible to continue minimisation to achieve an improvement, if only slight.

To continue with the minimisation program:

- Proceed as specified for reading Un.5 - reference mark (see next page).

To abort minimisation:

- Press the STOP key to return to the balancing program and balance the wheel according to the readings.

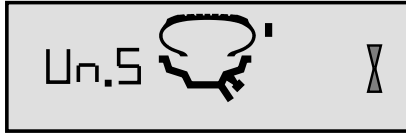

129

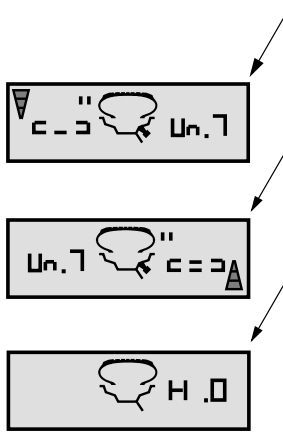
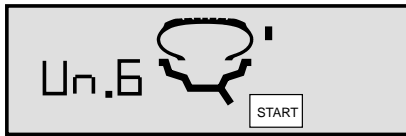

130

Reading Un.5 - reference mark (Fig. 129)

- After the measuring run index the wheel following the position reading and provide a crayon mark on the right side of the tire at 12:00 o'clock.
- Readjust the tire on the rim such that the tire mark coincides with the valve.
- Clamp the tire/rim assembly on the balancer and readjust such that the valve is at 12:00 o'clock.
- Press the PRO MATCH key to enter the valve position.

Reading Un.6 (Fig. 130) comes up.

- Press the START key.

The second measuring run of the tire/rim assembly is started. After the measuring run three readings are possible:

=== - Un.7 (see Fig. 131)

Proceed with the Un program. It is recommended that the tire be turned over on the rim.

Un.7 - === (see Fig. 132)

Proceed with the Un program. It is recommended that the tire be adjusted on the rim.

H 0 (see Fig. 133)

Optimum condition has been achieved and cannot be improved.

Depending on the readings, there are several possibilities for proceeding with the program. These possibilities are described below.

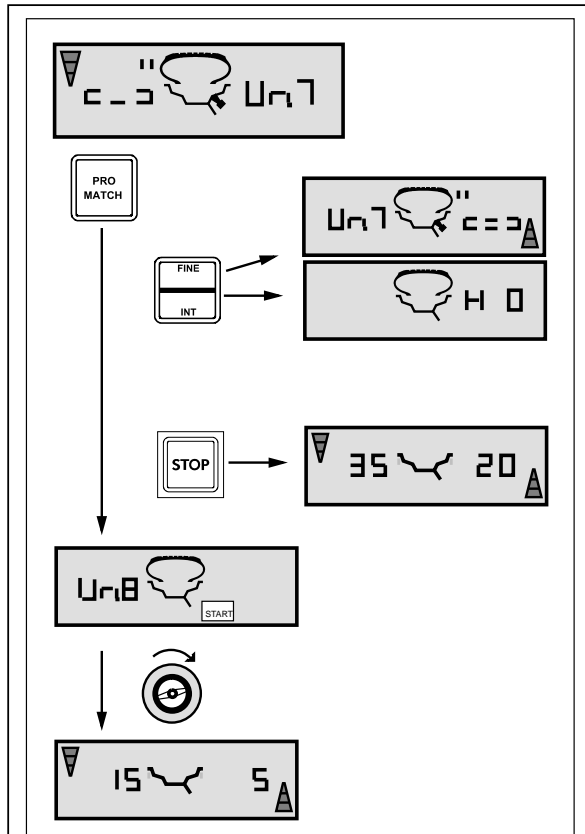

131

Reading === - Un.7 (Fig. 131)

Recommendation to turn tire over on the rim (the left display segments are rotating).

Choice 1: Turn tire over on the rim (standard program)

- Index the wheel following the **left** direction indicator and provide a double mark on the **left** side of the tire at 12:00 o'clock.
- Remove the wheel from the machine.
- Turn the tire over on the rim and readjust until the double mark coincides with the valve.
- Clamp the tire/rim assembly on the machine and readjust to 12:00 o'clock.
- Press the PRO MATCH key to enter the valve position.

Reading Un.8 comes up.

- Press the START key (check run).

If the minimisation run has been carried out correctly following the above sequence of operations, the balancer will return to the balancing mode selected before minimisation and read out the dynamic unbalance still left in the wheel (**Fig. 131**).

- Balance the wheel according to the readings.

Reading of error code E9

If E9 is read out, at least one error was made with respect to the sequence of operations when performing minimisation (see § 11. Error codes). Abort the minimisation program by pressing the STOP key and, if desired, start minimisation once again.

Choice 2: Do **not** turn tire over on the rim

- Press the FINE key.

The result is then converted.

Reading is Un.7 - = = = (see Fig. 132) or H0 (see Fig. 133).

- To return to === - Un.7 (turning over the tire), press the FINE key once again.

Choice 3

- Press the STOP key to return from the minimisation to the balancing program.

The unbalance present in the wheel is read out.

- Balance the wheel according to the readings.

Pro-Match/Weight minimisation

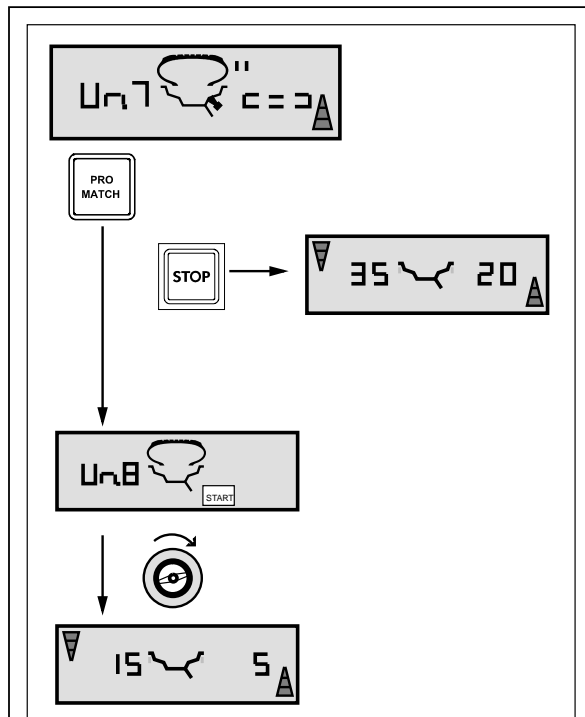

132

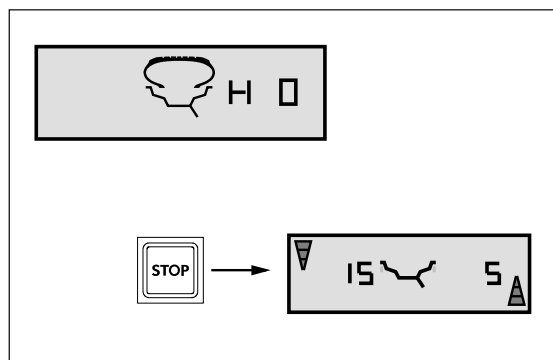

133

Reading Un.7 - === (Fig. 132)

Recommendation to readjust tire on the rim (the right display segments light up permanently).

Choice 1: Readjust tire on the rim (standard program)

- Index the wheel following the **right** direction indicator and provide a double mark on **right** side of the tire at 12:00 o'clock.
- Remove the wheel from the machine.
- Readjust the tire on the rim until the double mark coincides with the valve.
- Clamp the tire/rim assembly on the machine and turn until it is at the 12:00 o'clock position.
- Press the PRO MATCH key to enter the valve position.

Reading Un.8 comes up.

- Press the START key (check run).

If the minimisation run has been carried out correctly following the above sequence of operations, the balancer will return to the balancing mode selected before minimisation and read out the dynamic unbalance still left in the wheel (**Fig. 132**).

- Balance the wheel according to the readings

Reading of error code E9

If E9 is read out, at least one error was made with respect to the sequence of operations when performing minimisation (see § 11. Error codes). Abort the minimisation program by pressing the STOP key and, if desired, start minimisation once again.

Choice 2: Do **not** readjust tire on the rim

- Press the STOP key to return from the minimisation to the balancing program.

The unbalance present in the wheel is read out.

- Balance the wheel according to the readings.

Reading H 0 (Fig. 133)

Optimum condition has been achieved and cannot be improved.

- Press the STOP key to return to the balancing program and balance the wheel according to the readings.

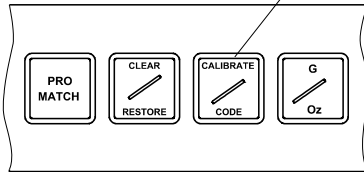

134

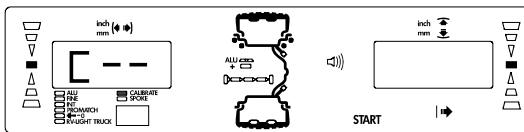

135

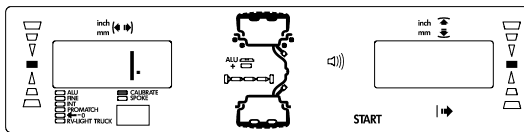

136

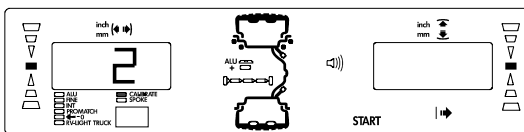

137

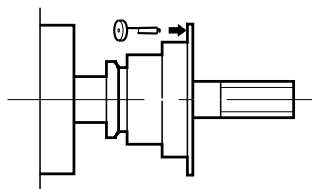

138

13. User calibration

If several measuring runs are necessary to balance a wheel because balance weight size and position have to be changed repeatedly, it may be necessary to readjust the machine.

For user calibration a calibration weight is supplied with the machine (ref. no. 6418 416 - kept on the right at the back of the weight tray).

Important:
Readjustment must be carried out using the clamping adapter supplied with the machine.

Readjustment (Code C14)

- Make sure no wheel or other clamping means is clamped on the machine.
- Press and hold the CODE key (Fig.134, item 1)

The basic reading C -- is read out (Fig. 135).

- Release the CODE key.

Reading 1. and START are read out (Fig. 136).

- Close the optional wheel guard, and press the START key to carry out a readjustment run.

On completion of the first run reading 2. and START are read out (Fig. 137).

- Screw the calibration weight into the threaded hole of the wheel adapter (Fig. 138).
- Press the START key.

On completion of the processing operation a three-tone signal is given and readjustment is completed.

- Remove the calibration weight from the wheel adapter and put it back in its designated place.

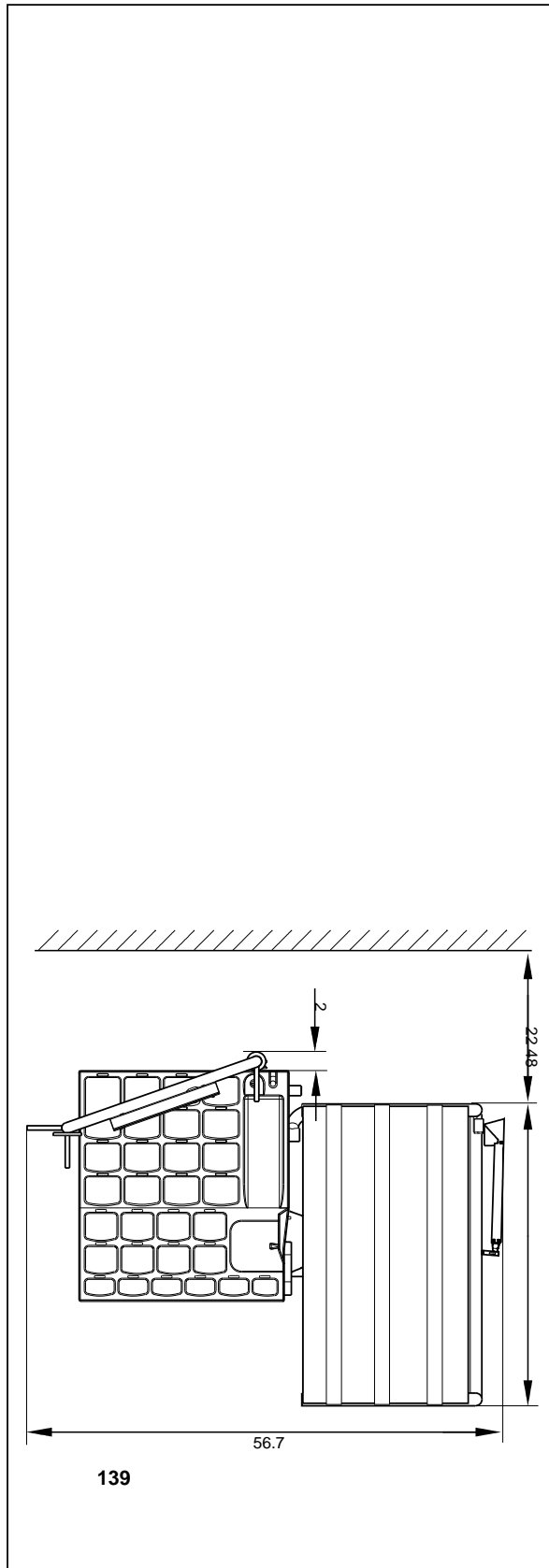

14. Maintenance

The wheel balancer requires almost no maintenance. Their bearings are greased for life and sealed. The drive belt does not require particular checks. If defects occur which cannot be eliminated by the user (error codes not mentioned under § 11. Error codes), contact your local Hofmann distributor or Hofmann for service at the numbers listed below.

14.1 After-sales service

Please contact your local agent (see last page).

Hofmann - USA

309 Exchange Ave
 Conway, AR 72032
 Ph: 800 251 4500
 Fax: 501 450 2085

Hofmann - Canada

6500 Millcreek Dr.
 Mississauga, Ontario L5N4G4
 Ph: 800 267 2185
 Fax: 905 821 2073

15. Technical Data

Machine dimensions	see Fig. 139
machine with wheel guard open	72.8 inches
machine	Weight of 225 lbs
115-120 V 50/60 Hz	Power supply 0.12 kW
Motor rating	Balancing speed 225 rpm (50 Hz)
Measuring time	3 s
Max. unbalance reading	14 oz
Resolution of amount reading	1 / 5 g or 0.05 / 0.25 oz
Resolution of position reading	0.7 deg.
Working temperature	0-45 °C
Relative humidity level	5-95 % at 40 °C
Noise	70 dB (A)
Working range	
Distance rim - machine	0-300 mm
Rim width	1-20 inches
Rim diameter	8-24 inches
Overall wheel diameter	44 inches
Overall wheel width	21 inches
Max. wheel weight	150 lbs

Fig. 139 Dimensions of wheel balancer

16. Electrical diagram

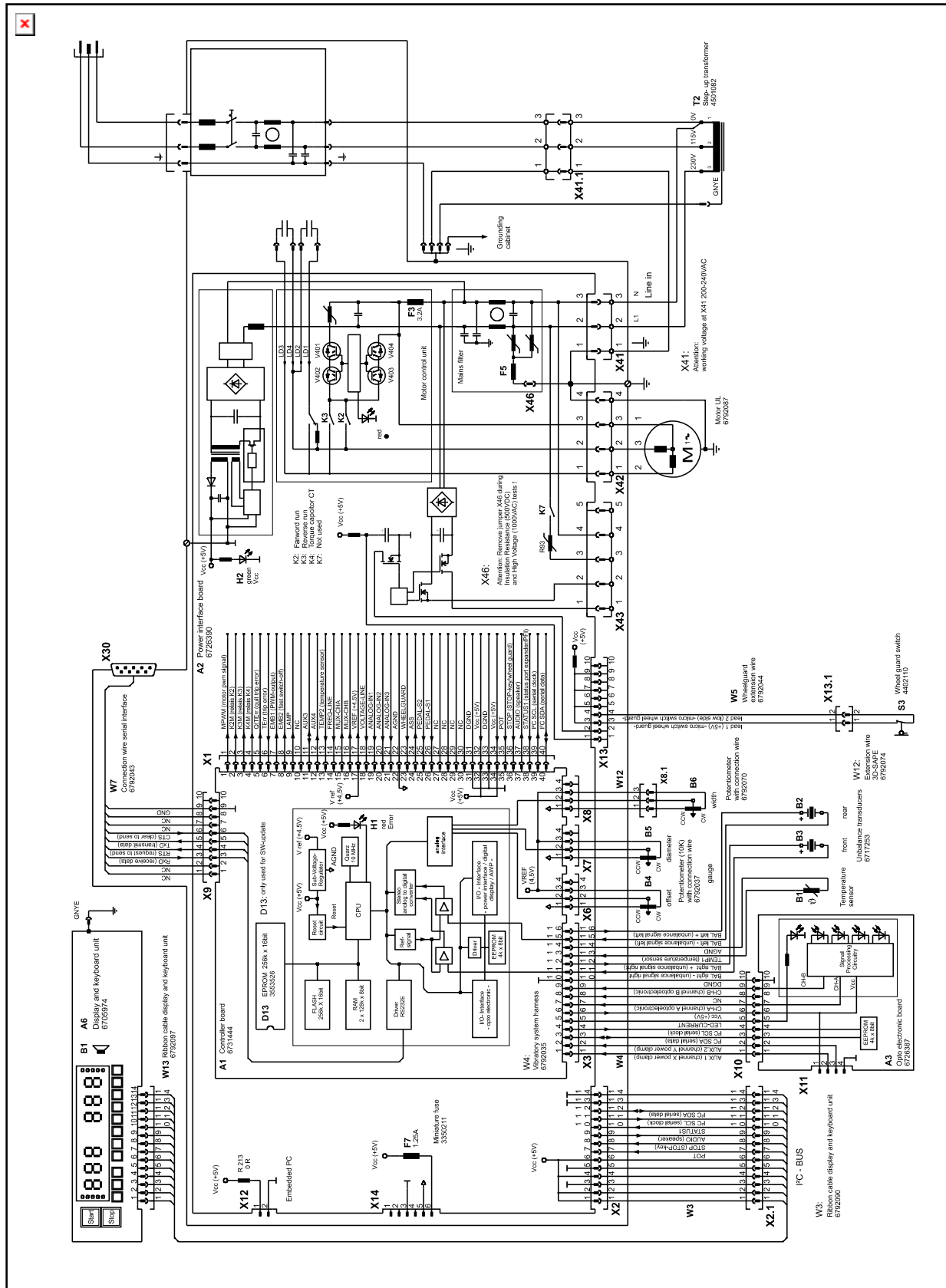

HOFMANN®



**Operator's Manual
Covers Hofmann Model 2800
EEWB704D**

Hofmann - USA

309 Exchange Ave
Conway, AR 72032
Ph: 800 251 4500
Fax: 501 450 2085

Hofmann - Canada

6500 Millcreek Dr.
Mississauga, Ontario L5N4G4
Ph: 800 267 2185
Fax: 905 821 2073