

Geodyna

Optima

Spare Parts Manual



HOFMANN



All information contained or disclosed in this document is considered confidential and proprietary by Snap-on Tools Company. All manufacturing, use, reproduction, and sales rights are reserved by Snap-on Tools Company and the information contained herein shall not be used in whole or in part without the express written consent of Snap-on Tools Company.

Table of Contents

Vibratory system with drive unit	2
Pedal assembly	3
Power clamping device	3
Cabinet and weight box	4
Display and wheel guard	5
Wheel guard damper	6
Wheel guard carrier	7
Blank Page	8
Geodata gauge for distance and rim diameter	9
Electronic unit	10
Rear scan unit	11
External scan unit	12
Rear covers and Electronic boards	13

1471.b

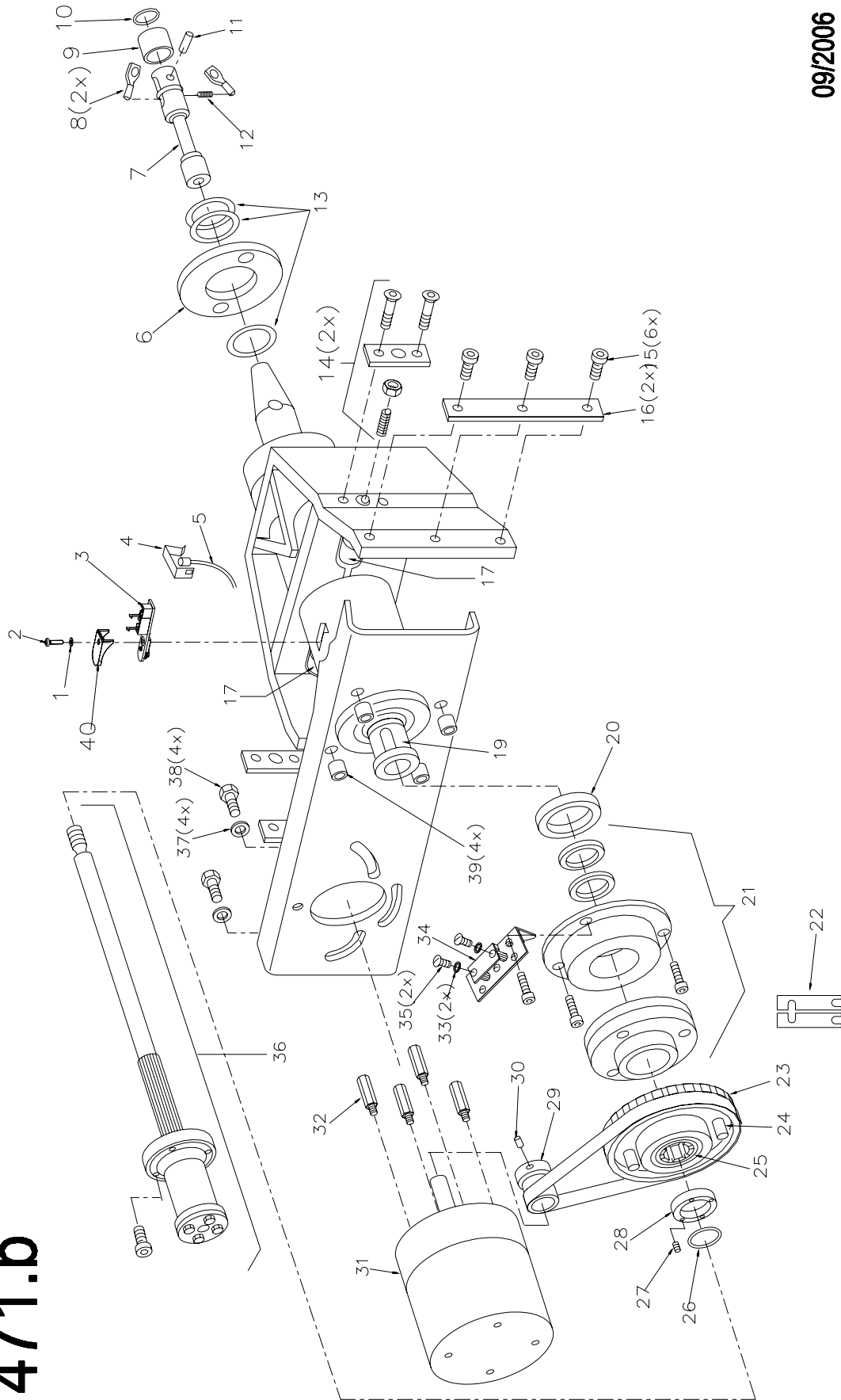

1470

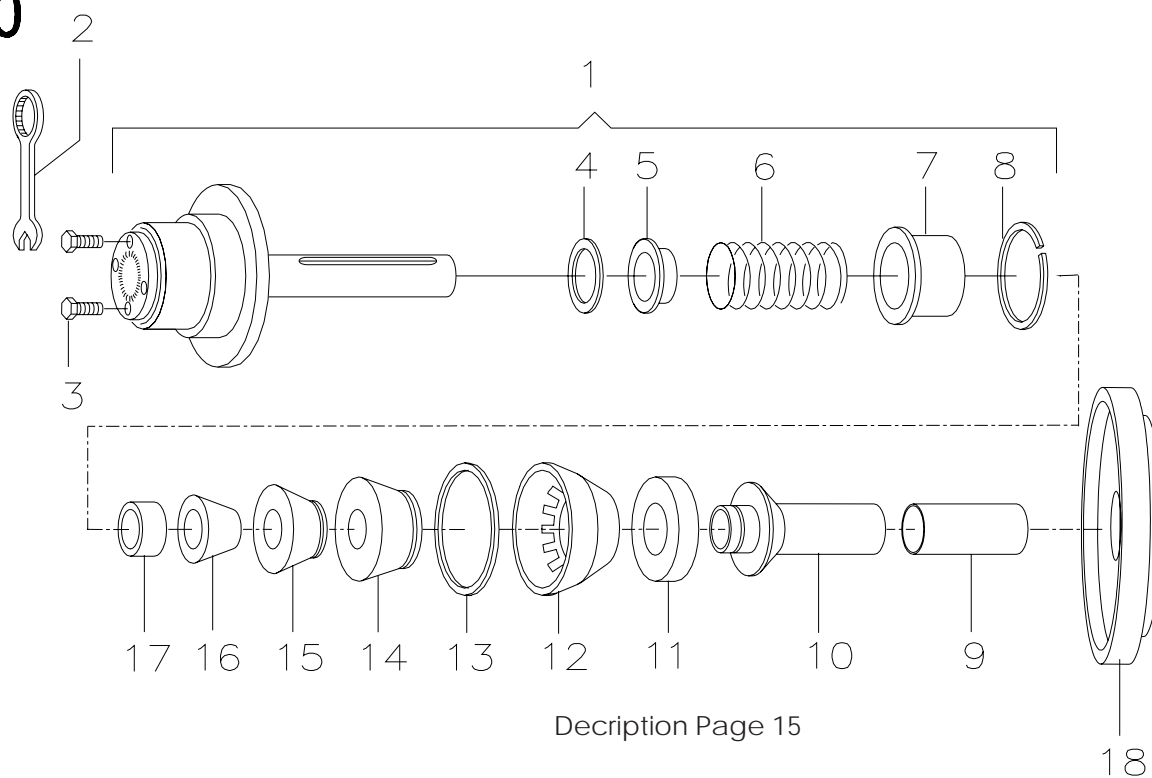

Pedal assembly

1561

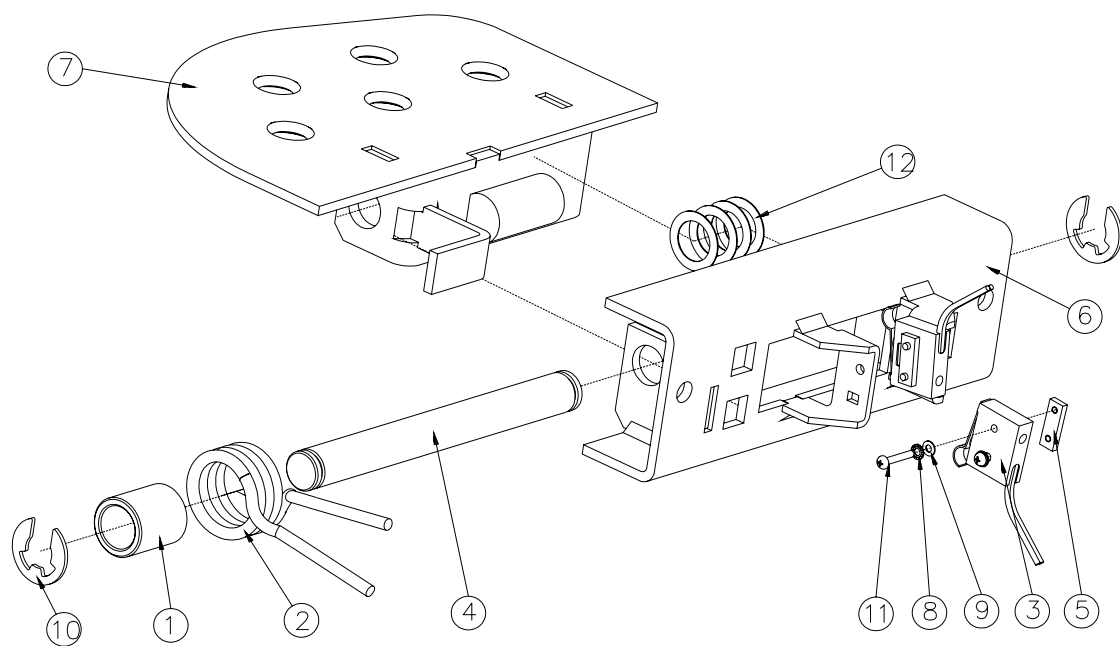

04/2006

1466

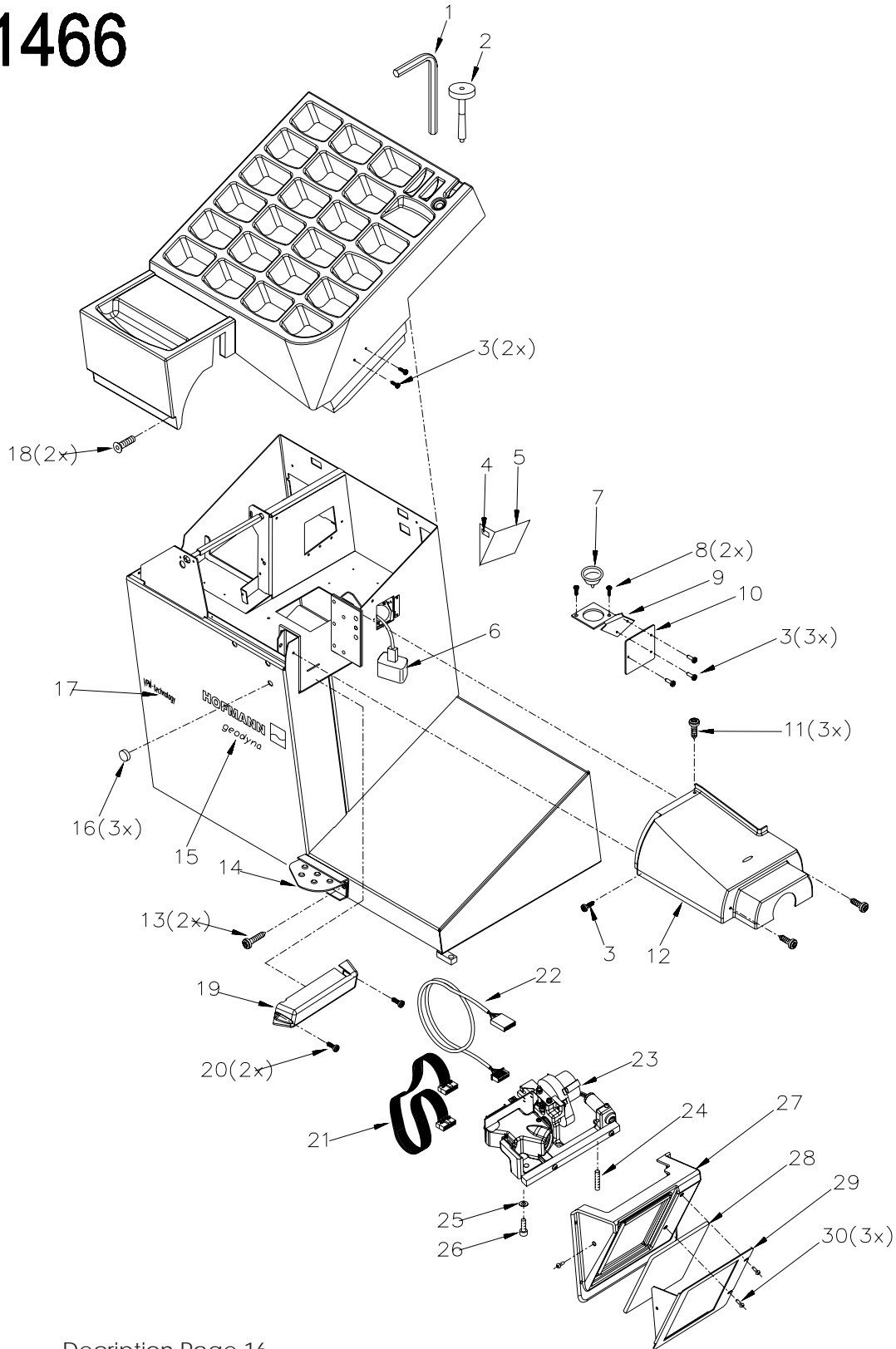

Description Page 16

09/2004

1465b

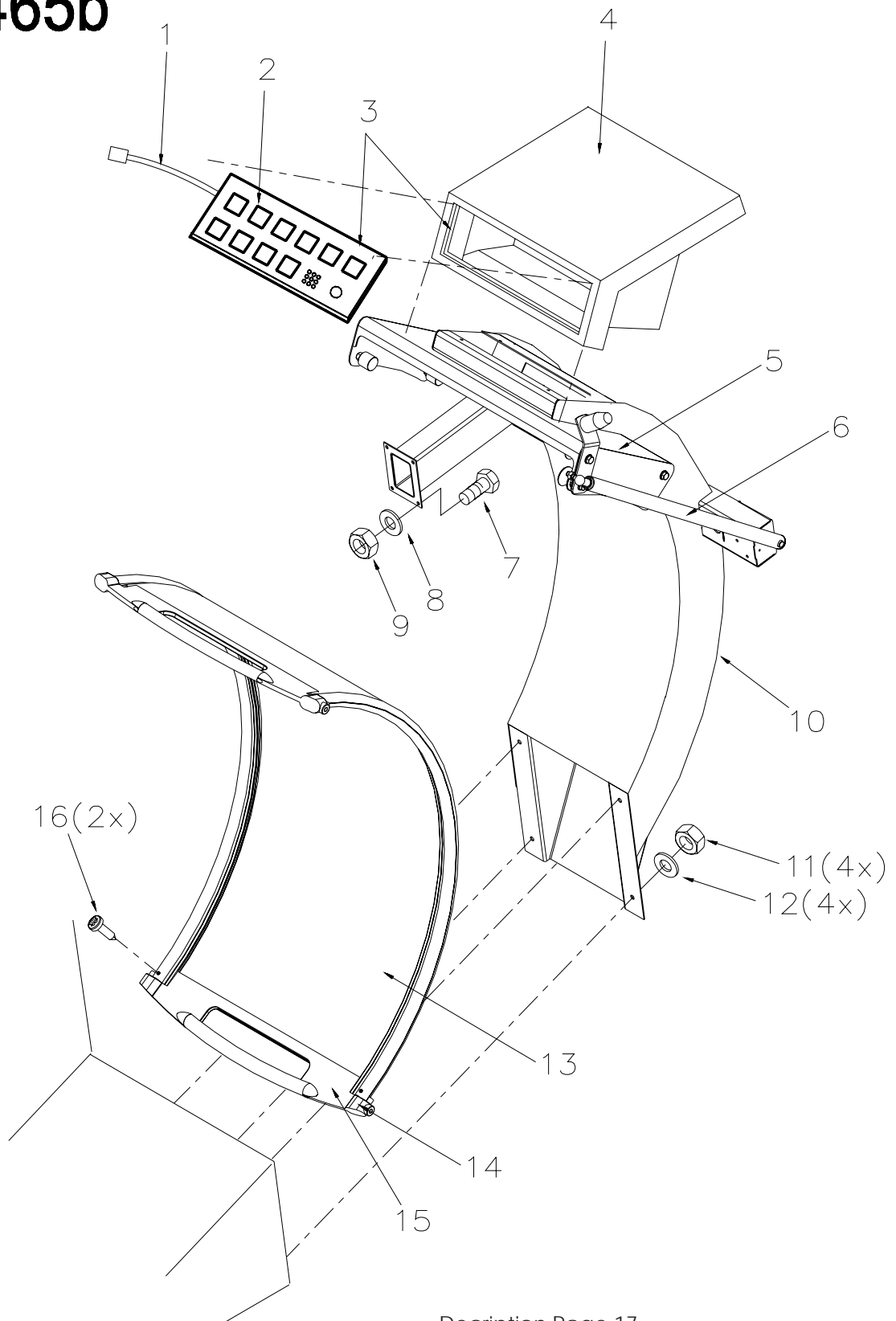

Decription Page 17

1464

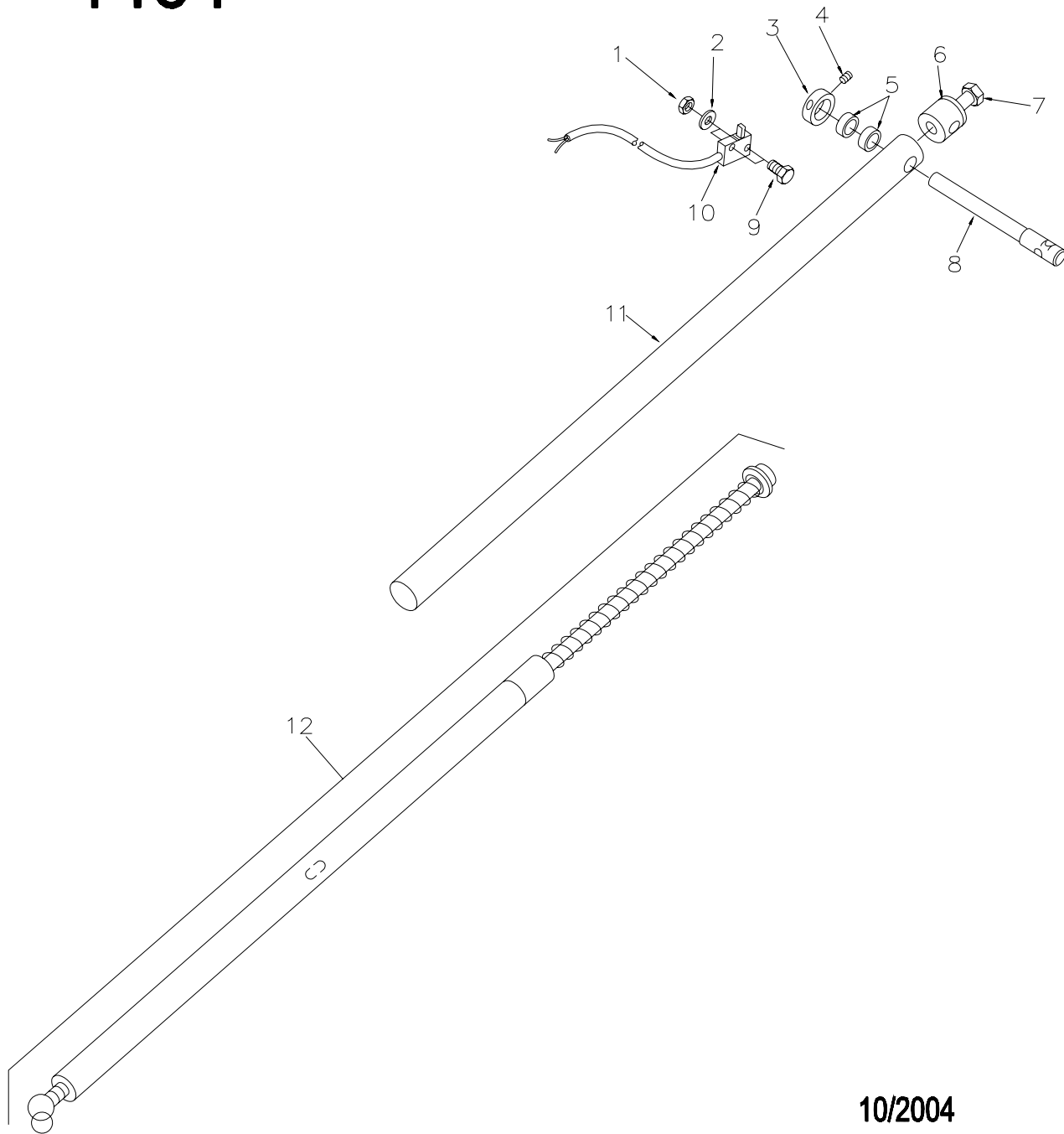

10/2004

Decription Page 17

Wheel guard carrier

1463

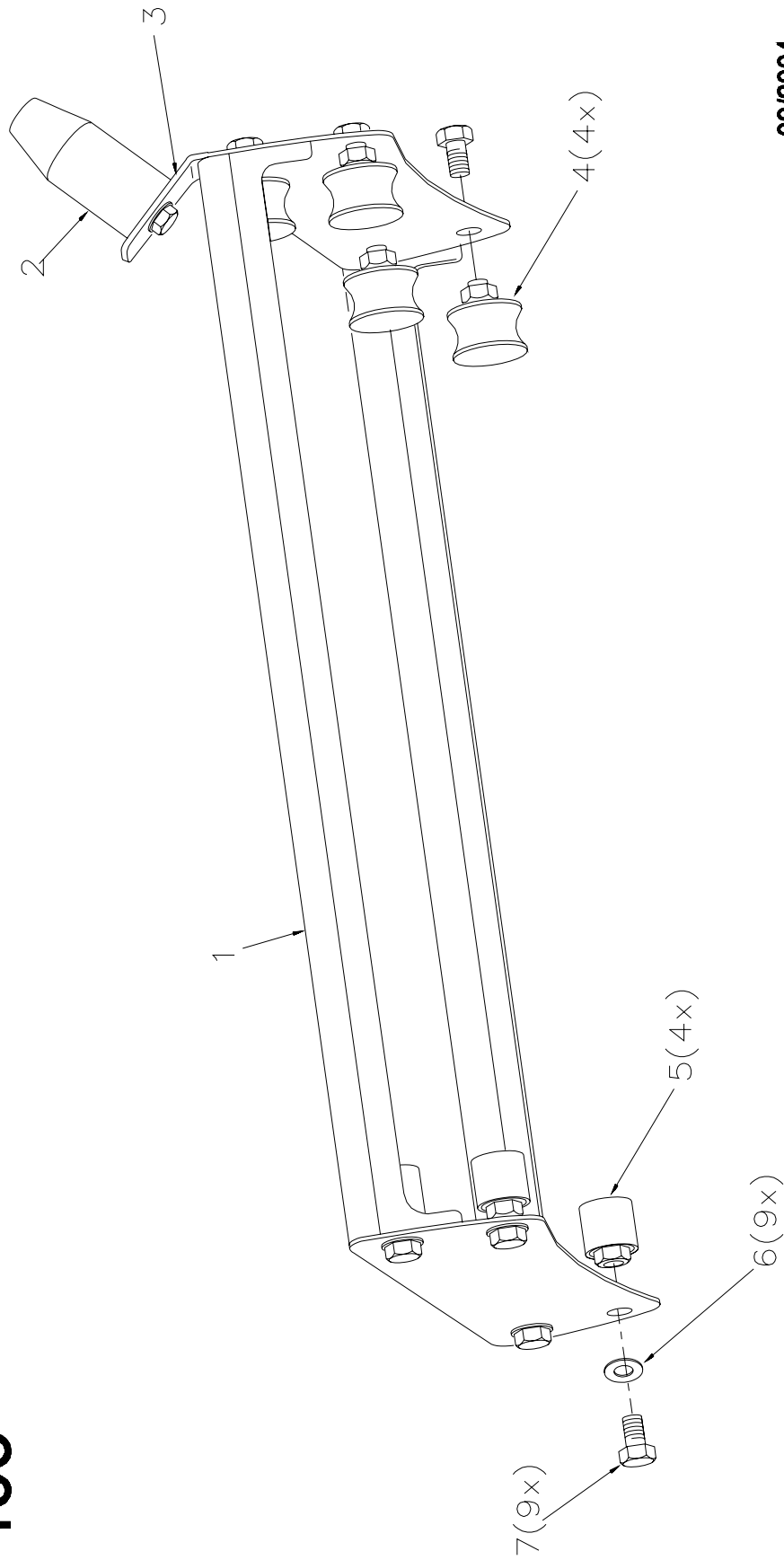

09/2004

Description Page 17

Blank Page

1467

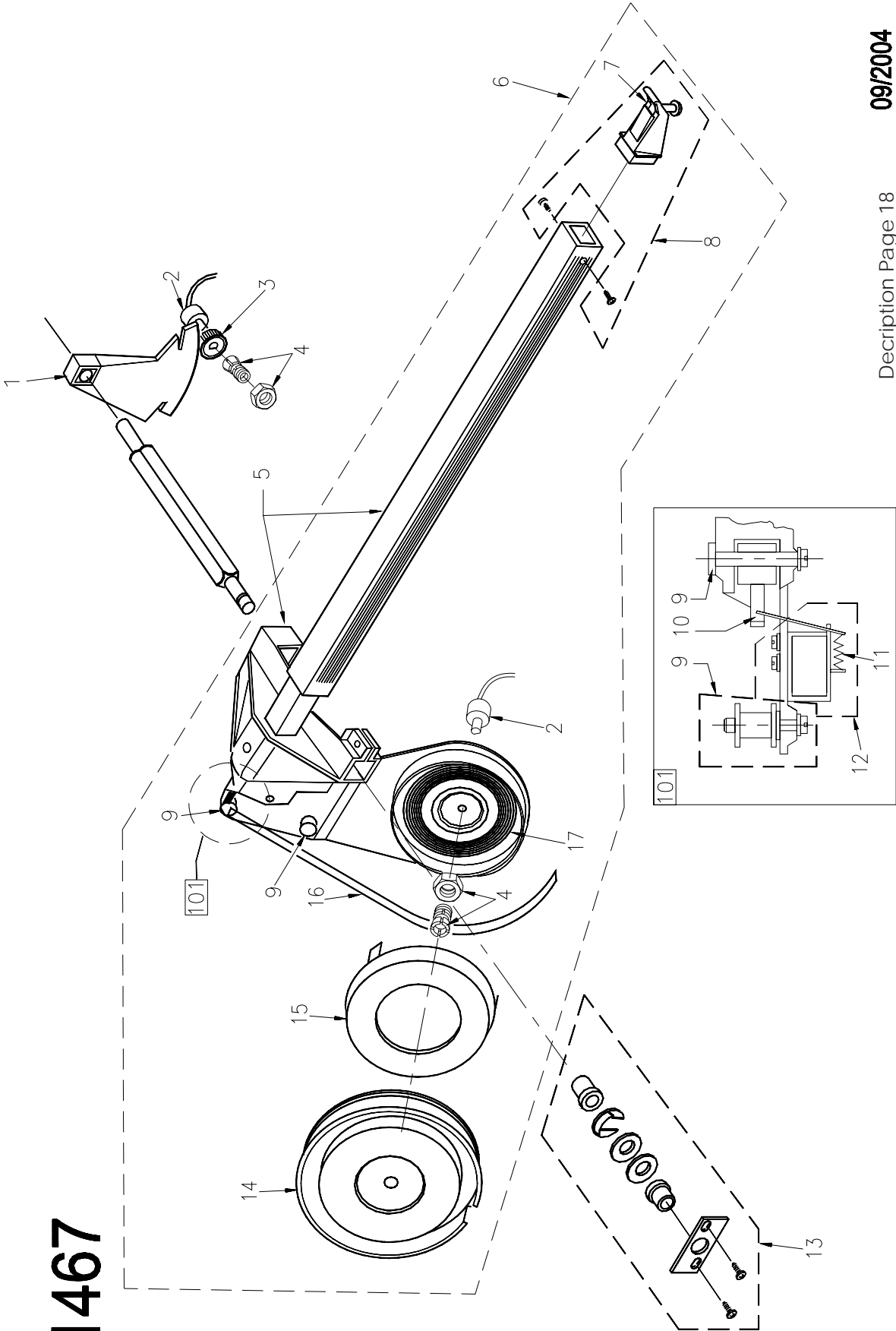

1459.a

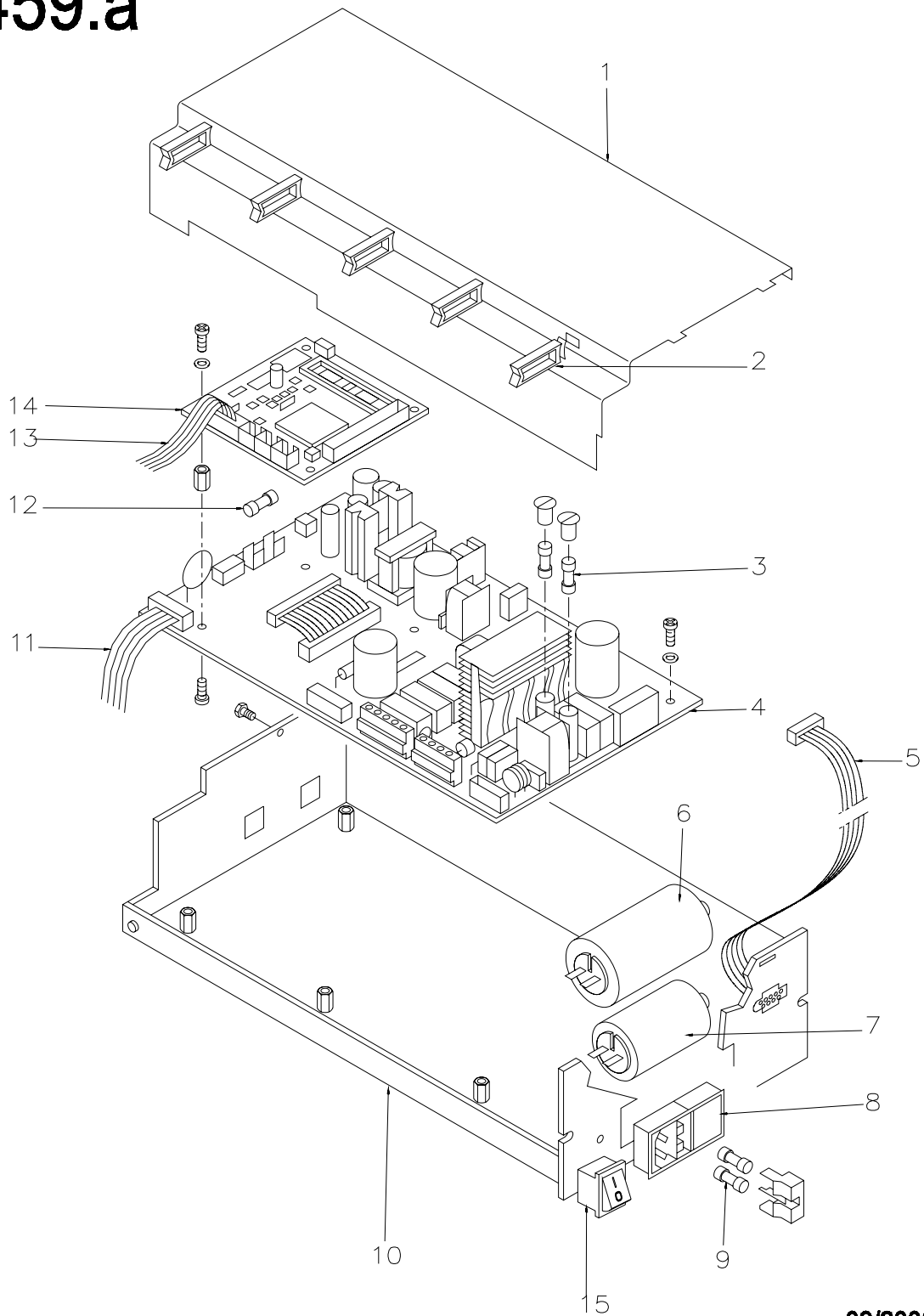

Decription Page 18

09/2006

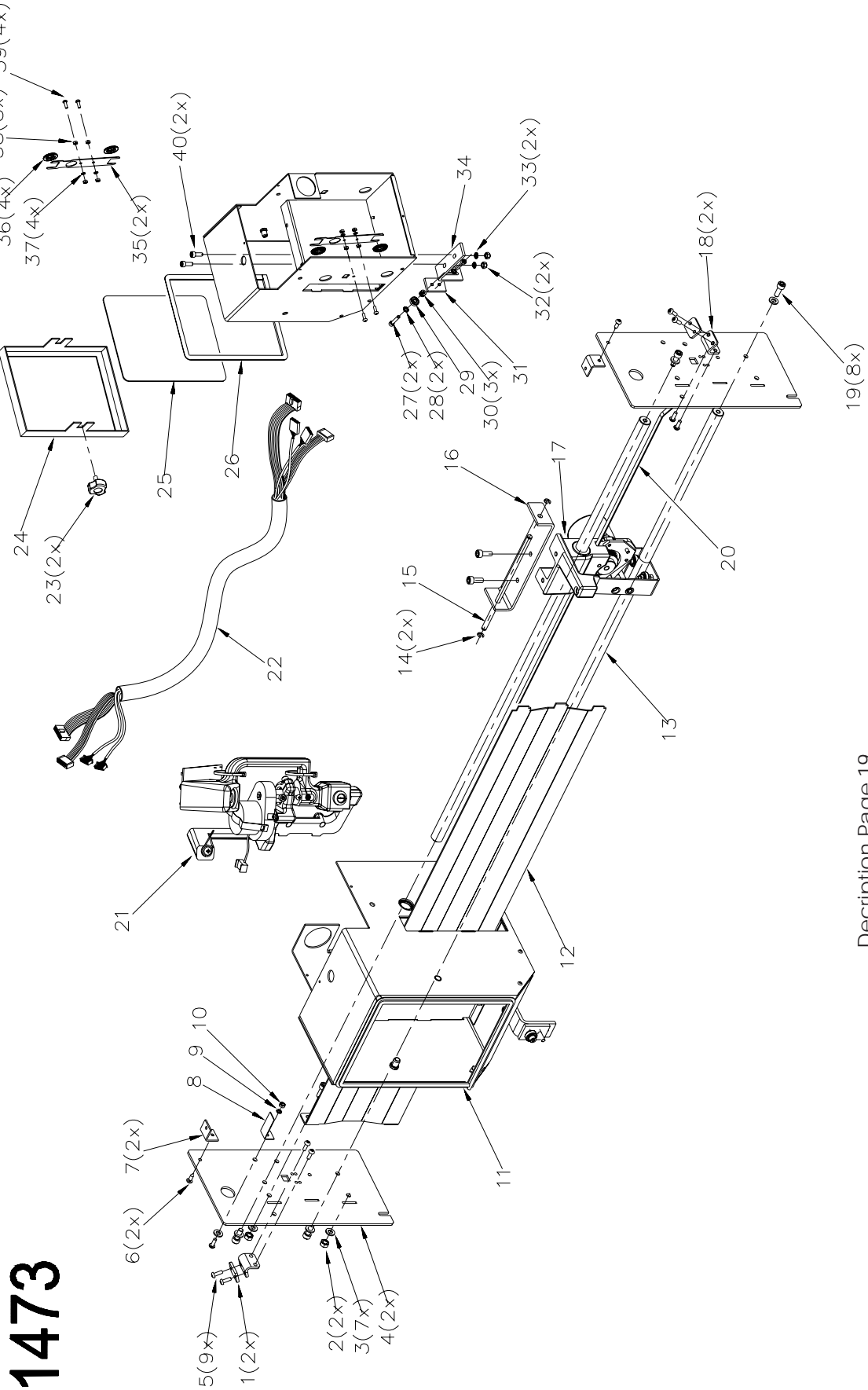

1473

Decription Page 19

09/2004

1474b

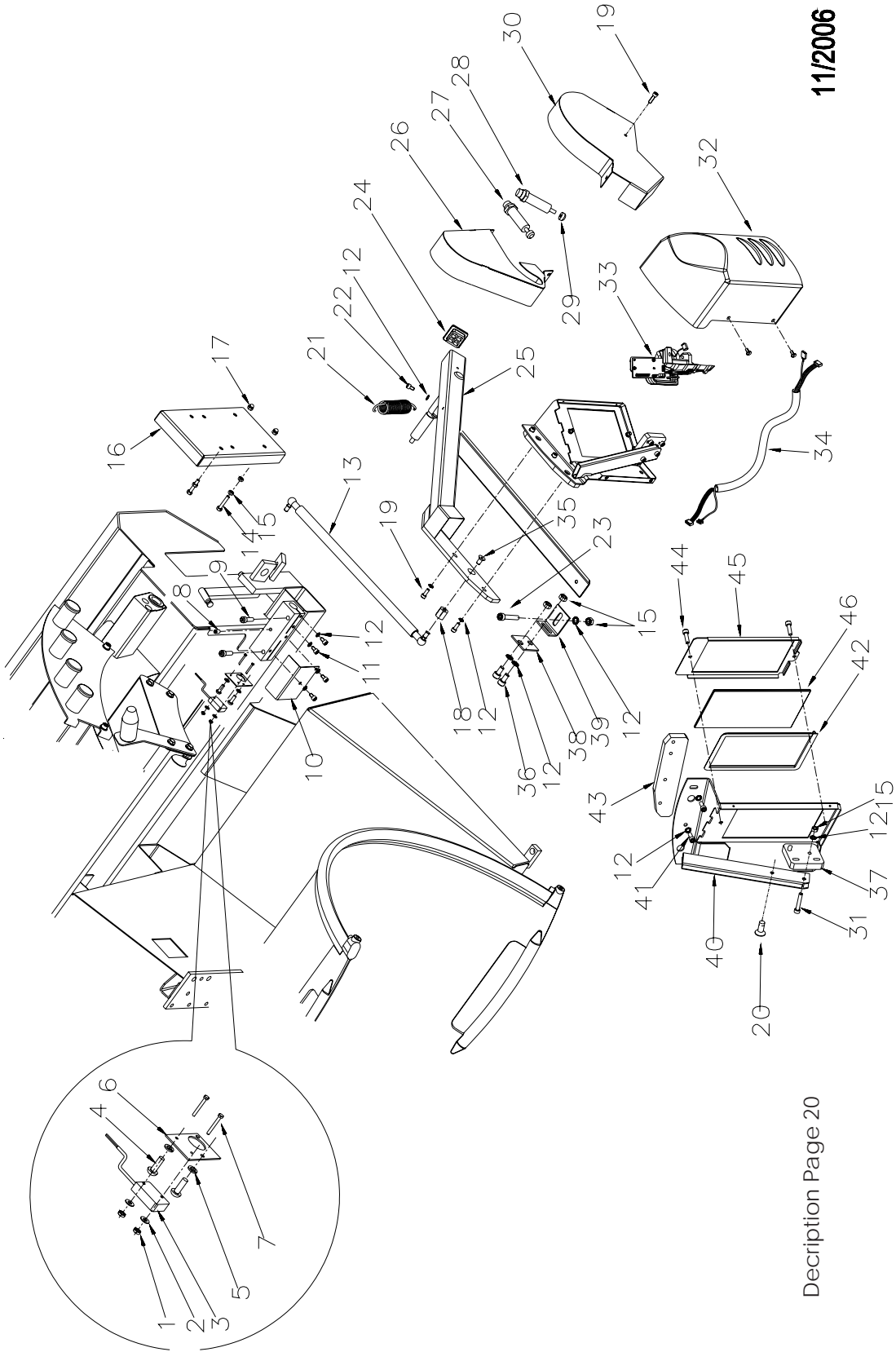

11/2006

Decription Page 20

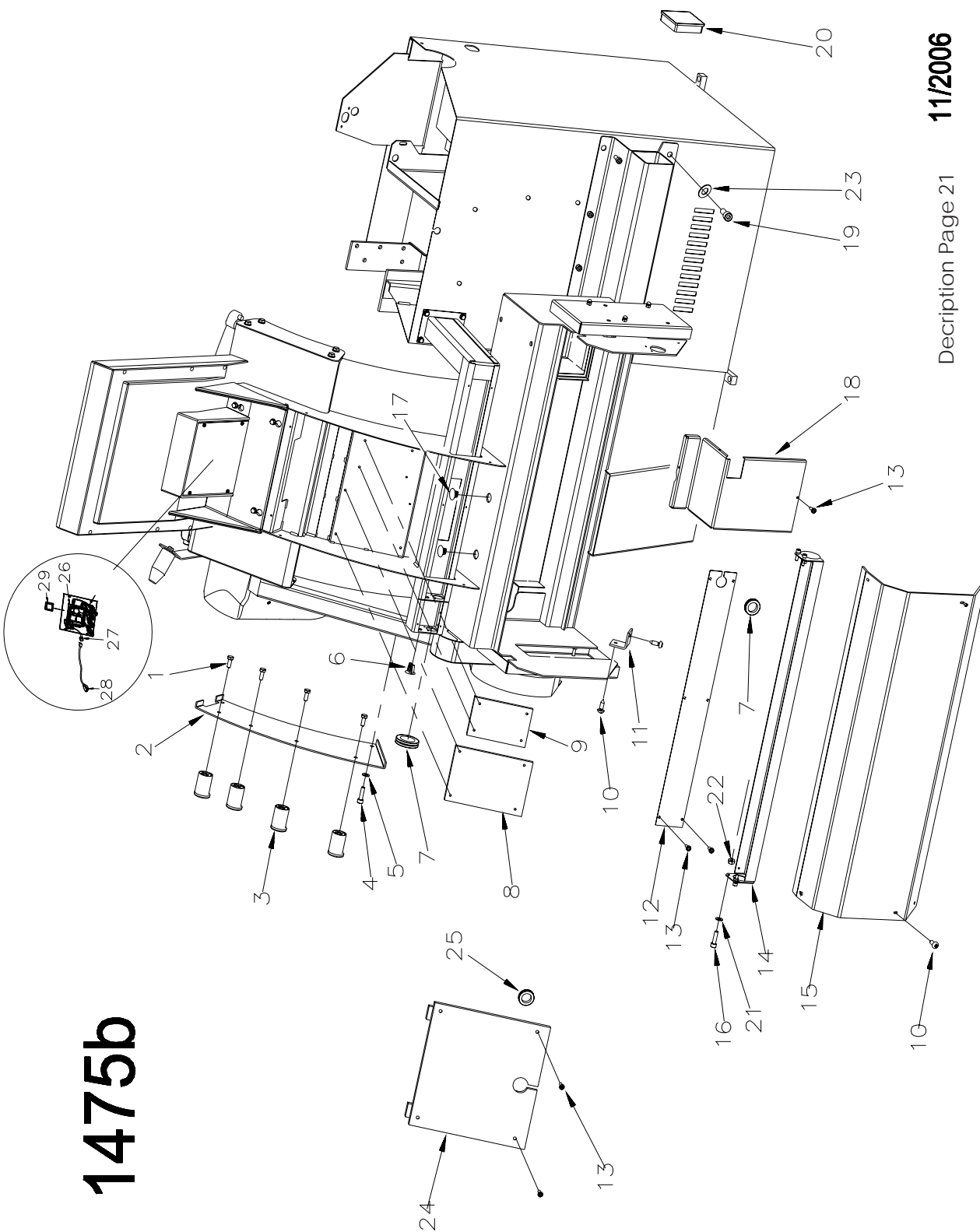

1475b

11/2006

Description Page 21

Fig. 1471: Vibratory system with drive unit

	EAA0344G06A	Vibratory system Optima	
1	1-9641	Washer	A4,3
2	1-13004	Oval head screw	M4 x 6
3	EAP0201D50A	Opto-electronic unit	
4	EAS2025D12A	Clip	
5	EAW0239D00A	Lead with temperature sensor	
6	EAM0005D57A	Bayonet disc	
7	EAM0021D31A	Yoke	
8	EAM0021D32A	Clamp	
9	1-09784A	Inner ring	LR25x30x38.5
10	1-14977A	SW25 Circlip	23.5x1.75x1.2
11	EAM0021D30A	Cylindrical pin	10m6 x 24
12	EAM0021D51A	Compression spring	1.1x7.4x41.5
13	EAA0307G37A	Fastening means of bayonet disc	
14	EAA0328G16A	Fastening means for transducer	
15	1-17709	Hex. socket head cap screw	M8 x 20
16	EAS2025D03A	Spacer for vibratory system	
17	EAA0260D59A	Transducer assembly	
19	1-09684A	Parallel key	A6x6x40
20	EAM0021D17A	Intermediate clip	40 x 9
21	EAA0283D86A	Brake disc repair kit	
22	EAK0257G05A	Spacer plates for brake (set)	
23	EAM0005D64A	Code bar	
24	EAM0021D18A	Drive pulley "p"	
25	1-03063A	Angular contact ball bearing	
26	1-15077A	Circlip	
27	1-48710A	Setscrew	M5 x 8
28	EAM0021D19A	Pressure ring "p"	
29	EAM0005D08A	Motor pulley	
30	1-28410	Setscrew	M6 x 8
31	EAA0266D31A	Motor	WS 120W
32	EAM0005D44A	Spacer for motor	
33	1-05747A	Tooth washer	J4
34	EAP0201D20A	Encoder board assembly	
35	1-13004	Oval head screw	M4 x 6
36	EAA0307G36A	Replacement kit "p" – die-cast nut	
37	1-11541	Washer	B6.4
38	1-30701	Hexagon bolt	M6 x 12

Fig. 1470: Power clamping device - Page 3

1	EAA0283D46A	Basic body of adaptor	
2	8-03850A	Wrench (width across flats 13 mm)	
3	1-46601A	Screw	M8 x 25
4	1-18241A	Washer	55x68x0.5
5	EAC0058D14A	Spring centring ring	
6	1-07768A	Compression spring	
7	EAS2025D14A	Spring casing	
8	1-13077	Circlip	
9	EAC0058D69A	Protective sleeve	
10	EAM0005D54A	Clamping sleeve	
11	EAC0058D08A	Pressure ring	
12	EAC0058D07A	Clamping head	
13	EAC0058D15A	Protective ring	
14	EAM0005D25A	Cone 96 – 116 mm	
15	EAM0005D24A	Cone 74 – 99 mm	
16	EAM0005D23A	Cone 42 – 77 mm	
17	EAC0058D68A	Spacer ring	

Fig. 1561: Pedal assembly

	EAA0332G26A	Brake pedal assy	
1	EAM0051G96A	Bushing cent. spring br. pedal	
2	EAM0048G78A	Spring, pedal switch	
3	2-07661A	Microswitch	
4	EAM0046G39A	Pedal pin	
5	EAM0046G40A	Threaded block	
6	EAS2090G15A	Brake pedal support	
7	EAS2089G80A	Welded pedal	
8	1-1048	Washer external shakeproof	D. 2mm
9	1-9341	Washer	A 2.2-A2J-DIN 125A
10	1-18477A	Retaining ring	10x1.2mmA2R DIN6799
11	1-9804	Screw, phillips head	M2x12
12	1-25241A	Shim ring	D12.2x18x0.3mm DIN988

Fig. 1466: Cabinet and weight box

1	8-01250A	Wrench	SW 14
2	EAM0005D40A	Calibration weight	
3	1-22623A	Screw	3.9 x 13
4	EAS2058D06A	Angular support	
5	EAA0283D51A	Mirror with adhesive strip	
6	EAA0266D25A	Transformer with lead	
7	2-06730A	Reflector with integrated halogen lamp	
8	1-22723A	Self-tapping screw	2.9 x 9.5
9	EAS2025D18A	Lamp holder	
10	EAC0058D65A	Protective screen	
11	1-31406A	Screw	M6 x 10
12	EAC0058D55A	Cover of vibratory system	
13	1-16409	Screw	M6 x 20
14		Pedal assembly	
15	EAL0345D58A	Decal geodyna	
16	1-06476A	Cap	
17	EAL0345D49A	Decal VPM-Technology	
18	1-19923	Screw	6.3 x 19
19	EAC0058D41A	Weight box, blue	
	EAC0058D86A	Weight box, black	
20	1-22623A	Self tapping screw	3,9 x 13
21	EAW0240G27A	CCD Inner Camera Cable	
22	EAW0240G30A	Motor Cable for Inner Scanner	
23	EAA0307G13A	Inside Scanner Assembled Unit	
24	1-49810A	Screw	M6 x 25
25	1-1548	Washer-Lock	D.6
26	1-16309	Screw	M6 x 16
27	EAA0307G65A	Inside Scanner Housing Complete	
28	EAM0006G67A	Glass	
29	EAS2086G63A	Bottom Glass Bracket	
30	1-22623A	Self tapping screw	3,9 x 13

Fig. 1465: Display wheel guard - Page 5

1	EAW0239D16A	Connecting lead keyboard unit	
2	EAA0307G67A	Keyboard unit	
3	1-09484A	Adhesive closure (male)	
	1-09384A	Adhesive closure (female)	
4	EAC0058D48A	Display casing, blue, geodyna	
	EAC0058D88A	Display casing, black, geodyna	
5	Wheel guard carrier assembly (see Fig. 9)		
6	Wheel guard switch assembly (see Fig. 8)		
7	1-46401A	Screw	M5 x 16
8	1-11441	Washer	5.3
9	1-18233A	Nut	M5
10	EAA0277D35A	Support of display unit	
11	1-15633A	Nut	M8
12	1-11741	Washer	8.4
13	EAA0277D86A	Wheel guard assembly	
14	8-09218A	End buffer	
15	EAC0058D26A	Wheel guard handle	
16	1-22723A	Self-tapping screw	2.9 x 9.5

Fig. 1464: Wheel guard damper

EAA0283D21A Wheel guard switch assembly

1	1-11233	Nut M3	
2	1-9541	Washer 3.2	
3	EAM0021D12A	Switch ring	
4	1-38910	Setscrew M4 x 8	
5	1-06065A	Bushing	
6	EAM0021D08A	Clamping sleeve	
7	1-16209	Screw M6 x 12	
8	EAM0021D11A	Arbor	
9	1-26901	Screw M3 x 20	
10	2-7261	Switch	
11	EAM0021D10A	Telescope pipe	
12	EAA0283D52A	Wheel guard damper	

Fig. 1463: Wheel guard carrier

	EAA0307G75A	Wheel guard carrier assembly (before 11/04 was:EAA0277D80A)	
1	EAA0313D99A	Wheel Guard Support	
2	EAM0005D69A	Cone	
3	EAS2025D40A	Angular support	
4	EAA0307G76A	Complete flat roller	
5	EAA0307G77A	Complete "U" roller	
6	1-10041	Washer 8.4	
7	1-32401	Screw M8 x 12	

Fig. 1467: Geodata gauge for distance and rim diameter

1	EAC0058D56A	Tooth segment	
2	EAA0266D20A	Potentiometer assembly with nut	
3	EAC0058D13A	Gear wheel	
4	2-07657A	Collet with nut	
5	EAA0328G18A	Gauge arm assembly	
6	EAA0277D85A	Gauge assembly with gauge head	
7	EAS2058D04A	Clip	
8	EAA0277D87A	Gauge head assembly	
9	EAA0307G34A	Arbor assembly	
10	EAC0058D29A	Clamping piece	
11	1-05467A	Tension spring for solenoid	
12	EAA0307G33A	Solenoid with fastening means	
13	EAA0328G23A	Fastening means with bushings	
17	1-03967A	Helical spring	
14	EAC0058D06A	Belt pulley	
15	EAC0058D58A	Cover	
16	EAA0277D96A	Toothed belt	960 mm
17	1-03967A	Helical spring	

Fig.1459: Electronic unit

EAA0266D11A Electronic unit assembly

1	EAS2025D02A	Cover of digital box	
2	2-08557A	Lead holder	
3	2-21151A	Fine-wire fuse, slow blow	3.5 A
4	EAP0201D10A	Power interface board	
5	EAW0239D13A	Ribbon cable controller board	
6	2-01529A	Capacitor	
7	2-01429A	Capacitor	
8	2-40348A	Power entry module	
9	2-21251A	Fine-wire fuse, slow blow	6.3 A
10	EAA0260D68A	Bottom of digital box	
11	EAW0239D03A	Connecting lead display and keyboard unit	
12	2-16951A	Fine-wire fuse, medium slow blow	1.25 A
13	EAW0239D00A	Connecting lead vibratory system	
14	EAP0201D00C	Controller board	

Fig. 1473: Rear scan unit – optima

	EAA0255J52A	Rear liner drive assembly	
1	EAM0003J52A	Stop belt	
2	1-11633A	Nut	M6
3	1-9841	Washer	6,4
4	EAS2081J16A	Support rod	
5	1-13304A	Screw	M4x12
6	1-20423	Self tapping screw	4,2x13
7	EAS208J11A	Rear cover support	
8	EAS2081J10A	Home position end stroke	
9	1-2546A	Washer spring single coil D.4	4.3
10	1-11433A	Nut	M4
11	EAA0255J53A	Linear drive box assembly with wipers	
12	EAS2081J14A	Cover	
13	EAM0003J41A	Rod	16mm
14	1-16977A	Retaining ring	D.5x0,7
15	EAM0003J55A	Support rod	
16	EAS2021J85A	Bracket	
17	EAA0307G40A	Drive assembly linear	
18	EAM0003J51A	Belt support	
19	1-16309	Screw	M6x16
20	8-04331A	Belt	
21	EAA0332G74A	External Scanner Assembly	
22	EAW0240G39A	Wiring harness rear scanner	
23	8-11330A	Knob	M6
24	EAS2021J84A	Rear scanner cover-glass	
25	1-11784A	Glass	
26	5-03241A	Adhesive seal	
27	1-15209	Screw	M5x25
28	1-1448	Tooth washer	D.5 E
29	1-03963A	Bearing	5x16x5
30	1-9741	Washer	5,3
31	EAS2021J92A	Ball bearing block adjuster	
32	1-9933	Nut	M6
33	1-1548	Tooth washer	D.6 E
34	EAS2021J91A	Support box guide	
35	EAS2081J20A	Wipers holder	
36	8-08914A	Wipers rod	16mm
37	1-2546A	Washer spring single coil D.4	4.3
38	1-11433A	Nut	M4
39	1-13304A	Screw	
40	1-16309	Screw	M6x16

Fig. 1474: External scan unit – optima

1	1-19233A	Self locking nut
2	1-9541	Washer
3	2-7261	Micro switch
4	1-13304A	Screw
5	1-9541	Washer
6	EAS2086G48A	Micro switch support
7	1-26901	Screw
8	1-22210A	Screw
9	1-17909	Screw
10	EAS2076G45A	Microswitch cover
11	1-47909A	Screw
12	1-1548	Tooth washer
13	EAA0307G61A	Articulated joint tube
14	1-16809A1	Screw
15	1-11633A	Nut
16	EAS2086G47A	Cover
17	1-3035	Nut
18	EAM0042G06A	Tube Spacer
19	1-16409	Screw
20	1-16609A	Screw
21	EAM0006G06A	Spring
22	1-47909A	Screw
23	1-16509A1	Screw
24	1-08876A	Cap
25	EAS2086G03A	Scanner support
26	EAS2086G35A	Inner cover
27	1-04969A	Shock absorber with nut
28	1-04869A	Shock absorber with Nut
29	1-05069A	Cap for shock absorber
30	EAS2086G39A	External cover
31	1-16709	Screw
32	EAC0060G50A	Cover for external laser
33	EAA0332G74A	External Scanner Assembly
34	EAW0240G38A	Wiring harness outer scanner
35	1-23403A	Screw
36	1-16209A1	Screw
37	EAM0003J40A	Lower block for scanner
38	EAS2086G53A	Inf. support scanner
39	EAS2086G51A	Inf. support tube
40	EAS2021J75A	Support wldmt external scanner
41	1-16309	Screw
42	5-03241A	Adhesive seal
43	EAM0003J56A	Upper block for scanner
44	1-13709	Screw
45	EAS2021J79A	Glass support
46	1-11784A	Glass

Fig. 1475: Rear covers and Electronic boards – Page 13

1	1-32601	Screw	M8x20
2	EAS2086G54A	Cone support	
3	EAC0058D54A	Conical bolt	
4	1-17909	Screw	M8x30
5	1-17741	Washer	8,4
6	8-08176A	Cap	9,5>13,5
7	8-08716A	Grommet	32mm
8	EAP0204G50B	Camera Processor Board	
9	2-37666A	10V Power Supply	
10	1-20423	Self tapping screw	4,2x13
11	EAS2081J11A	Rear Cover Support	
12	EAA0313D24A	Channel cover	
13	1-22623A	Self tapping screw	3,9x13
14	EAS2021J86A	Cable Support	
15	EAC0060G51A	Rear device Cover	
16	1-16409	Screw	M6x20
17	1-09076A	Cap	14>21
18	EAS2086G32A	Cover for rear scanner	
19	1-17709	Screw	M8x20
20	1-08976A	Cap	80x80
21	1-1548	Washer-Lock	6
22	1-11633A	Nut	M6
23	1-17841	Washer	8x24
24	EAA0313D23A	Back side cover	
25	8-08916A	Snap Bushing	25.5 mm
26	EAA0307G58A	Embedded PC without flash	
27	EAW0239D24A	Power cord	
28	EAW0239D25A	Extension power cord	
29		Flash board with data (Call for current Part Number)	

HOFMANN



HOFMANN USA

309 Exchange Avenue
Conway, AR 72032
Phone 800-251-4500
Fax 501-450-2085
www.hofmann-usa.com

HOFMANN BALANCING TECHNIQUES LTD. CANADA

6500 Millcreek Dr.
Mississauga, Ontario L5N 4G4
Phone 800-267-2185
Fax 905-821-2073
www.hofmann.ca

Notice: The information contained in this document is subject to change without notice. **Snapon Equipment** makes no warranty with regard to this material. **Snapon Equipment** shall not be liable for errors contained herein or for incidental consequential damages in connection with furnishings, performance, or use of this material.

This document contains proprietary information which is protected by copyright and patents. All rights are reserved. No part of this document may be photocopied, reproduced, or translated without prior written consent of **Snapon Equipment**.