

geodyna 9600p

Operation instructions

Wheel balancer



Form ZEEWB723A

HOFMANN®



SAFETY INFORMATION

**For your safety, read this manual thoroughly
before operating the HOFMANN 9600P Wheel Balancers**

The Hofmann 9600P Wheel Balancers are intended for use by properly trained automotive technicians. The safety messages presented in this section and throughout the manual are reminders to the operator to exercise extreme caution when servicing tires with these products.

There are many variations in procedures, techniques, tools, and parts for balancing tires, as well as the skill of the individual doing the work. Because of the vast number of wheel and tire applications and potential uses of the product, the manufacturer cannot possibly anticipate or provide advice or safety messages to cover every situation. It is the automotive technician's responsibility to be knowledgeable of the wheels and tires being serviced. It is essential to use proper service methods in an appropriate and acceptable manner that does not endanger your safety, the safety of others in the work area or the equipment or vehicle being serviced.

It is assumed that, prior to using the HOFMANN 9600P Wheel Balancer, the operator has a thorough understanding of the wheels and tires being serviced. In addition, it is assumed he has a thorough knowledge of the operation and safety features of the rack, lift, or floor jack being utilized, and has the proper hand and power tools necessary to service the vehicle in a safe manner.

Before using the HOFMANN 9600P Wheel Balancer, always refer to and follow the safety messages and service procedures provided by the manufacturers of the equipment being used and the vehicle being serviced.



IMPORTANT !! SAVE THESE INSTRUCTIONS -- DO NOT DISCARD !!

IMPORTANT SAFETY INSTRUCTIONS

When using this equipment, basic safety precautions should always be followed, including the following:

1. **READ ALL INSTRUCTIONS.**
2. **Do not operate equipment with a damaged power cord or if the equipment has been damaged - until it has been examined by a qualified authorized service technician.**
3. **If an extension cord is used, a cord with a current rating equal to or more than that of the machine should be used. Cords rated for less current than the equipment may overheat. Care should be taken to arrange the cord so that it will not be tripped over or pulled.**
4. **Always unplug equipment from electrical outlet when not in use. Never use the cord to pull the plug from the outlet. Grasp plug and pull to disconnect.**
5. **To reduce the risk of fire, do not operate equipment in the vicinity of open containers of flammable liquids (gasoline).**
6. **Keep hair, loose fitting clothing, fingers and all parts of the body away from moving parts.**
7. **Adequate ventilation should be provided when working on operating internal combustion engines.**
8. **To reduce the risk of electric shock, do not use on wet surfaces or expose to rain.**
9. **Do not hammer on or hit any part of the control panel with weight pliers.**
10. **Do not allow unauthorized personnel to operate the equipment.**
11. **Do not disable the hood safety interlock system or bypass the intended operation.**
12. **Use only as described in this manual. Use only manufacturer's recommended attachments.**
13. **Always make sure the power clamp is secure before spinning the shaft.**
14. **ALWAYS WEAR SAFETY GLASSES. Everyday eyeglasses only have impact resistant lenses, they are NOT safety glasses.**
15. **Balancer is for indoor use only.**
16. **This equipment uses class II lasers. Do not look into or allow bystanders to look into the laser source.**

SAVE THESE INSTRUCTIONS

CAUTION! This product uses LASER RADIATION for measurements. DO NOT STARE INTO BEAM.

Refer to these laser safety statements whenever this sign is displayed.



Peak power 1.0 mW.
Pulse duration 5 m sec.
Emitted wavelength 650nm.

Class II laser product. Caution - the use of optical instruments with this product will increase risk of eye hazard.



WARNING!!! DO NOT STARE INTO LASER BEAM! EYE INJURY MAY OCCUR WITH PROLONGED EYE CONTACT WITH LASER. AVOID EYE CONTACT WITH THE LASER SCANNERS

WARNING!!! IN THE EVENT OF MACHINE MALFUNCTION, DO NOT LOOK INTO THE LASER AREA. PROLONGED EXPOSURE TO THE LASER MAY CAUSE EYE INJURY.



PERFORM REGULAR CLEANING OF THE LASER SCANNER GLASS TO ENSURE OPTIMUM OPERATION.

DO NOT KNOCK OR TAMPER WITH THE LASER SCANNERS

ALWAYS OPERATE THE WHEEL BALANCER WITHIN THE RANGES STATED IN THE LABEL SHOWN BELOW.



WARNING!!!SEVERE PERSONAL INJURY WILL OCCUR IF FINGERS OR HAND IS PINCHED BETWEEN THE CLAMP NUT, WHEEL OR FLANGE



Table of Contents

SAFETY INFORMATION	3
1.0 INTRODUCTION	8
1.1 SAFETY NOTICE	9
1.2 BALANCER APPLICATION	9
1.3 HOFMANN 9600P SPECIFICATIONS	9
1.4 FEATURES	10
1.5 STANDARD ACCESSORIES	10
1.6 OPTIONAL ACCESSORIES	11
1.6 PRE-INSTALLATION CONSIDERATIONS	11
1.7 DIMENSIONS OF THE MACHINE	11
1.8 INSTALLATION AREA REQUIREMENTS	12
1.9 INSTALLATION PRECAUTIONS	12
2.1 INSTALLATION OF THE HOOD GUARD	13
2.2 INSTALLATION OF THE MONITOR	13
2.3 ELECTRIC INSTALLATION	13
2.4 SETUP	13
3.0 PHYSICAL LAYOUT	15
3.2 MENU KEYS	16
3.2.2 MAIN MENU FUNCTIONS	17
3.2.3 BALANCING	17
3.2.8 FUNCTION (SETUP)	19
4.0 HELP INFORMATION	20
5.0 POWER CLAMP	21
6.0 OPERATION OF THE BALANCER	22
6.1 CHECK LIST - INSPECTION	22
6.2 BALANCE SCREEN DESCRIPTION	23
6.2.1 WHEEL MOUNTING	24
6.2.2 STANDARD WHEELS (BACK CONE MOUNT)	24
6.2.3 CENTERING LIGHT-TRUCK WHEELS	24
6.3 SCAN MODE SELECTION	25
6.3.1 DATA FREEZE MODE	25
6.4 SPINNING THE WHEEL	25
6.5 SELECTING THE WEIGHT PLACEMENT	26
6.6 CORRECTION OF THE IMBALANCE	26
6.6 PROCEDURE WHEN SCANNER FAILS TO ACQUIRE A VALID PROFILE	27
6.7 VERIFICATION OF THE RESULTS	27
6.8 VIBRATION PROBLEMS	28
7.0 SPOKE BALANCING MODE	28
9.0 WEIGHT MANAGEMENT	29
8.0 OPTIMISATION PROCEDURES	32
10.0 USER CALIBRATION	37
11.0 EXPLANATION OF PROGRAM CODES	38
12.0 MAINTENANCE	40
13.0 TROUBLE SHOOTING	40

1.0 INTRODUCTION

Congratulations on purchasing the **HOFMANN 9600P** Computer Wheel Balancer. This wheel balancer is designed for ease of operation, accuracy, reliability and speed. With proper maintenance and care your wheel balancer will provide many years of trouble-free operation.



HOFMANN 9600P Computer Wheel Balancer - Precautions To Observe

Your HOFMANN 9600P Balancer utilizes the latest in electronics and instrumentation technology, incorporating two separate scanning lasers along with an embedded computer (PC). Following the precautions listed below will help to ensure continuous and satisfactory operation of your unit.

- 1) Install the balancer on a dedicated power line in order to avoid electrical noise and power line fluctuations. Avoid power cord length greater than 15 feet.
- 2) The 9600P Wheel Balancer utilizes a red scanning laser which actually create an image of the wheel being serviced. Install the balancer away from direct sunlight so that the laser can be detected by the scanner. Avoid placing high intensity lamps and infrared heaters near the 9600P balancer.
- 3) Profile and balance only those wheels which fit within the specifications of the 9600P Balancer:
Rim width = 3 - 20 inches
Rim diameter = 8 - 30 inches
Max tire diameter = 44 inches
Minimum distance required from cabinet to rim edge = 56 mm (2.20 inches) for wheel sizes 13-18 inches in diameter.
Minimum distance required from cabinet to rim edge = 81 mm (3.19 inches) for wheel sizes 19-24 inches in diameter.
- 4) The 9600P balancer is designed to properly scan the profile of existing rims. Extreme geometric combinations of rim diameter and flange offset can inhibit the proper viewing of the rim profile. These exceptional rims can be properly balanced by manually entering the distance, diameter, and width of the rim.
- 5) The wheel guard of the 9600P Wheel Balancer also serves as the housing for sonic transducer. Since the transducer must remain stationary once the spin cycle begins, do not lean on or otherwise disturb the wheel guard until the spin cycle has been completed.

Instructions on use, operational requirements and routine maintenance of the machine are covered in this manual.

This unit uses an open source Linux operating system for its user interface. This open source code is available for the cost of shipping and handling to owners of the 9600P Wheel Balancer. Requests must be made to the attention of balancer product management at the Conway AR address listed on the back of this manual. Please include the owners name, address and unit serial number with all requests.

**STORE THIS MANUAL IN A SAFE PLACE FOR FUTURE REFERENCE.
READ THIS MANUAL THOROUGHLY BEFORE USING THE MACHINE.**

1.1 SAFETY NOTICE

This manual is a part of the balancer product.

Read carefully all warnings and instructions of this manual since they provide important information concerning safety and maintenance.

1.2 BALANCER APPLICATION

The HOFMANN 9600P Computer Wheel Balancer is intended to be used as a device to correct imbalance and correct car, and light truck wheel vibration problems within the following range:

Maximum tire diameter	:	44" (1117mm)
Maximum wheel diameter	:	30" (762mm)
Maximum wheel width	:	20" (381mm)
Maximum wheel weight	:	154 lbs (70 kg)

This device is to be only used in the application for which it is specifically designed. Any other use shall be considered as improper and thus not reasonable.

The manufacturer shall not be considered liable for possible damages caused by improper, wrong or non reasonable use.

1.3 HOFMANN 9600P SPECIFICATIONS

Weight Imbalance Accuracy	.05 oz / 1 gram
Weight Placement Resolution	± .7 degrees
Weight Imbalance Resolution:	
Roundoff Mode	.25 oz / 5 grams
Non-Roundoff Mode	.05 oz / 1 gram
Max. Shaft Weight Capacity	154 lbs / 70 kg
Max. Tire Diameter	44" / 1117 mm
Rim Width Capacity	3.0"-20" / 76 mm - 508 mm
Max. Tire Width	21" / 530 mm
Rim Diameter Capacity	8"-30"/203mm-762mm
Balancing Cycle Time.	20 seconds or less
Shaft Speed at calculation	200 RPM
Electrical	115vac, 1ph, 50-60Hz, 8A
Required Work Area	64" x 64" (1626 x1626 mm)
Shipping Weight, complete	645 lbs/293kg
Shipping Dimensions	72"L X 73"W X 63"D (1829x1854x1600mm)
Machine Dimensions	64"h 64"w 64"d (1626x1626x1626mm)
Actual Weight with Accessories	550 lbs
Operating Temperature Range	32-122F / 0-50C

1.4 FEATURES

- Self test check with every power up cycle.
- Pre-programmed Error Codes indicate procedural errors or safety concerns.
- Fully Automatic All-Parameter Data Entry.
- Fully Automatic Rim Profiling.
- Weight Miser™ and Weight Wizard™ software
- Fully Automatic Spoke/Split Weight Function for Hidden Weight Placement.
- Hands-Free Power Clamping for Precise Wheel Placement.
- Captured back spring eliminates having to handle the backing spring.
- Automatic recalculation if weight positions are changed. No need for re-spinning the wheel.
- Common 40 mm diameter mounting shaft.
- Easy-to-Read LCD Data Display Monitor.
- Dynamic and single weight Static capability.
- Stop-at-Top features simplifies weight imbalance location
- Automatic Weight Type Selection Based on Rim Profile, Indicated by Color Coded Icons
- Built-in spin counter for monitoring balancer productivity.
- Service code access to all Balancer electronic functions for fast, easy diagnosis.
- Operator selectable roundoff mode.

1.5 STANDARD ACCESSORIES

Standard accessories (Figure 1) included with the HOFMANN 9600P are:

1	EAM0005D25A	Cone, 96-115 mm / 3.7"-4.52"
2	EAM0005D24A	Cone, 72-99 mm / 2.8"-3.9"
3	EAM0005D23A	Cone, 43-77 mm / 1.7"-3.0"
4	EAC0058D15A	Soft Protective Ring
5	EAC0058D07A	Cup - Large Pressure
6	EAM0005D54A	Plastic Sleeve
7	EAA0283D53A	Power Clamp Nut
8	EAM0005D40A	Weight - Shaft Calibration
9	EAC0058D08A	Small Pressure Disk
10	EAA0247G21A	Caliper - Rim Width
11	EAC0060G02A	Flange - Cover, Hook
12	EAM0006G01A	Pin - Accessory
13	58839	Weight Pliers

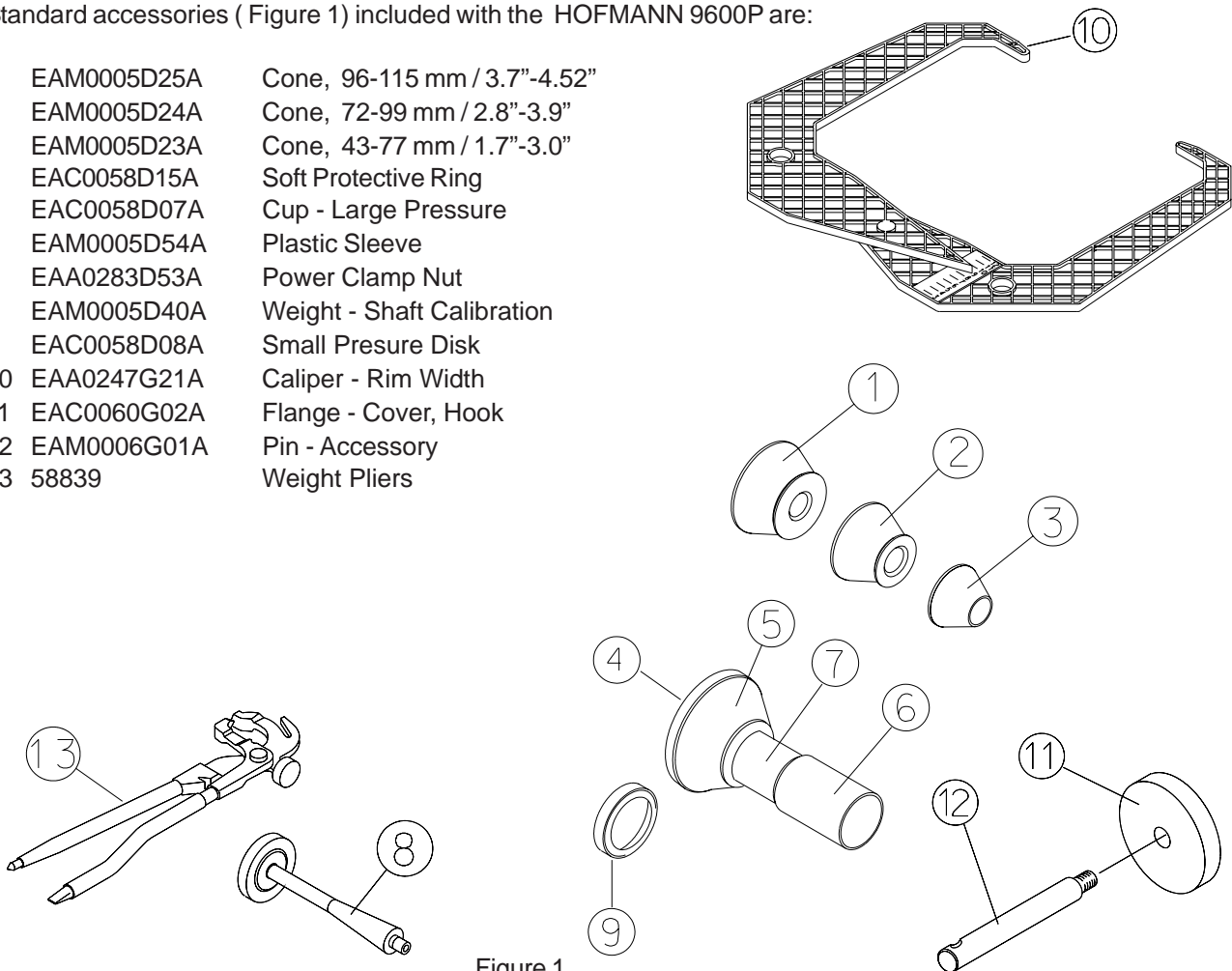

Figure 1

1.6 OPTIONAL ACCESSORIES



Wheel Lift - EAK0221J27A



Printer Kit - EAK0221J26A



Stick-on Weight Removal Tool
EEHT300A



Flange Plates - Kit of 4
EAK0221J22A



Flange Plate Cart
EAS2081J30A

Figure 2 - Optional Accessories

PRE-INSTALLATION CONSIDERATIONS

1.7 DIMENSIONS OF THE MACHINE

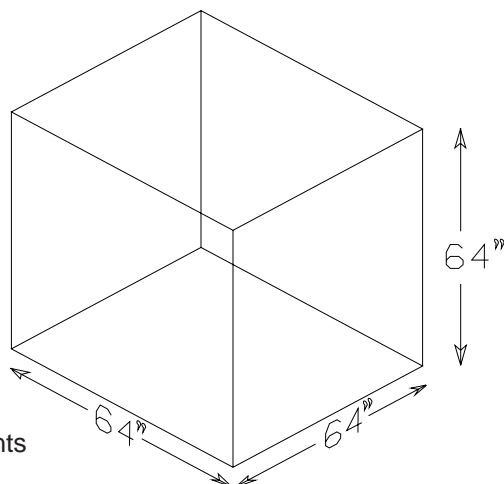

Figure 3 - Footprint Requirements

1.8 INSTALLATION AREA REQUIREMENTS

Make sure that from the operating position the user can see all of the machine and the surrounding area.

The operator should prevent non authorized persons and/or objects from entering the area which may create potential hazards.

The machine should be installed on a stable level floor. Do not install the machine on a uneven floor.

If the balancer is to be installed on a raised floor, the floor must have a capacity of at least 110lbs per sq ft. (5000 N/m² - 500 kg/m²).

It is not required to secure the machine to the floor but is recommended.

Install the machine in a dry, covered area.

The installation of the machine requires a working area of at least 64" x 64" (1626 x1626 mm). See Figure 3

1.9 INSTALLATION PRECAUTIONS

CAUTION! CAREFULLY REMOVE THE BALANCER FROM THE PALLET.

Remove the hardware that secures the machine to the pallet and slide the balancer onto the floor where it is to be installed.

THE UNIT IS HEAVY AND THE WEIGHT IS NOT EVENLY DISTRIBUTED.

DO NOT LIFT THE BALANCER BY THE SHAFT OR WHEEL GUARD FRAME.

DROPPING THE UNIT MAY CAUSE PERSONAL INJURY OR EQUIPMENT DAMAGE.

2.0 INSTALL ACCESSORY PINS

A. Install the accessory pins (Figure 4). Tighten firmly.

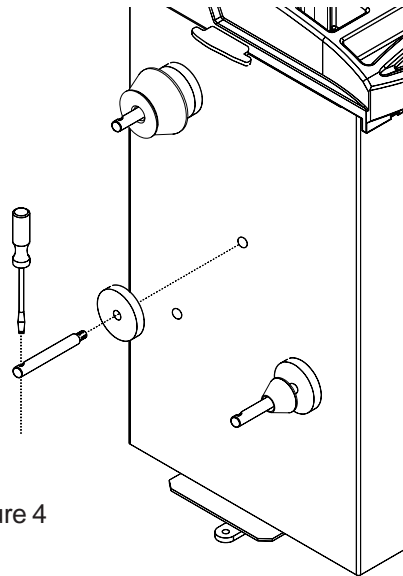

Figure 4

B. Place accessories onto the accessory pins.

2.1 INSTALLATION OF THE HOOD GUARD

- 2.1.1 Place the hood guard frame onto the pivot tube. Line up the holes in both frame and pivot, insert bolt. Secure using the supplied nut in the down position.
- 2.1.2 Connect the sonic transducer cable to short cable on the rear of the cabinet.
- 2.1.3 Pivot the frame up and down carefully and make sure the guard moves freely, the cable does not bind and the guard does not fall by itself.

2.2 INSTALLATION OF THE MONITOR

- 2.2.1 Place the display monitor onto the top of the control housing. Secure with the band strapping.
- 2.2.2 Connect the video and power cables to the monitor.
- 2.2.3 Connect the video cable to the video port located at the rear of the control housing.
- 2.2.4 Connect the power cord to a power outlet.

2.3 ELECTRIC INSTALLATION

ANY ELECTRICAL WIRING MUST BE PERFORMED BY LICENSED PERSONNEL.

ALL SERVICE MUST BE PERFORMED BY AN AUTHORIZED SERVICE TECHNICIAN.

Check on the plate of the machine that the electrical specifications of the power source are the same as the machine. The machine uses 115VAC (+/- 15%), 50-60Hz, 1Ph, 8 Ampere.

NOTE: ANY ELECTRICAL OUTLET INSTALLATION MUST BE VERIFIED BY A LICENSED ELECTRICIAN BEFORE CONNECTING THE BALANCER.

NOTE: THIS MACHINE PERFORMS A SELF-TEST ROUTINE ON START-UP. THERE WILL BE A DELAY OF SEVERAL MOMENTS BEFORE UNIT IS READY FOR OPERATION. ANY PROBLEMS DETECTED AT START-UP WILL RESULT IN THE DISPLAY OF AN ERROR CODE. PROBLEMS DETECTED DURING OPERATION ARE SAVED TO A LOG FILE WHICH CAN BE RETRIEVED FOR DIAGNOSIS BY A TECHNICIAN.



2.4 SETUP

Every shop has different procedural requirements meaning each machine should be customized to the unique services performed at that location. Most attributes are set from the Main Function menu.

2.4.1 Customizing the System

- A. Select the "Function" key (F1) from the "Welcome" menu. The Main Function setup screen appears as in Figure 5 as show on next page.
- B. Press and hold the "F6" button and rotate the shaft to scroll up or down to the desired line item.
- C. Press and hold the "F5" button and rotate the wheel to change selected topic to desired value or function.
- D. When the desired features have been selected, save selections to permanent memory by selecting line item "3". Hold the F5 button while rotating the shaft, enter a value of "1", release to **Save to Permanent Memory**.
- E. Select the "ESC" button on the keyboard to return to the main screen.

Balancer operating mode (0 = manual, 1 = profiling)	1
Setting factory default modes of operation	0
Saving modes of operation in permanent memory	0
Language selection	English – uk
Volume of the audible signals	50
Resolution of the unbalance amount readings	Normal
Suppression of minor unbalance readings	On
Setting threshold value for unbalance suppression in oz	0.25 oz
Measurement unit of the unbalance amount readings	Ounces
Number of revolutions	10
Starting a measuring run by closing the wheel guard	On
Automatic braking when wheel guard is raised	On
Releasing of the power clamping device disabled	Off
Actuation direction of pedal for clamping/releasing	Raise
Date: Day	11.--
Date: Month	--.04.--
Date: Year	--.--.06
Time: Hour	12:--
Time: Minute	--:30
Counter (total spins / spins with ok)	1555 2
Counter (optimisation runs / clamping cycles)	5 15
Counter (since last calibration / service)	126 11
Screensaver timeout (0 = disabled)	0
Position brake and indexing	2
Networkmode (0=no network, 1=ASA)	0
Machine name in network	WB01
Printing	Off
Paper size	Letter
Printer model	HP Deskjet D2430
Print on unclamping	Off
Advanced spoke detection	Off
Weight usage tracking	On
Weight Placement Default Selection	Auto
Rim cleaning position brake control	Off
Allow unclamping of wheel only if imbalance = 0 and OK	Off
Enable WeightMiser	On
Setting static threshold value for WeightMiser in oz	0.20 oz
Setting dynamic threshold value for WeightMiser in oz	0.35 oz
WeightMiser clip weight to money conversion	1 / lb
WeightMiser stick weight to money conversion	1 / lb

Figure 5



Figure 7

3.0 PHYSICAL LAYOUT

Refer to Figure 7. - Functional description of the unit:

1. The screen
2. Input panel
3. Gauge arm
4. Stub shaft with power clamp nut
5. Brake pedal
6. Weight compartments
7. Storage areas for cones or clamping devices
8. Tilting frame and hood guard
9. Sonic Transducer
10. Inner scanner
11. Main Power switch (ON/OFF), rear



3.1 The Display Screen

See Figure 8, Screen with display fields

- 1-5 Information fields
- 6 Menu fields and Function descriptors.
- 7 Display field of screen
The screen reads out inputs, helpful information, all measured data and error codes.

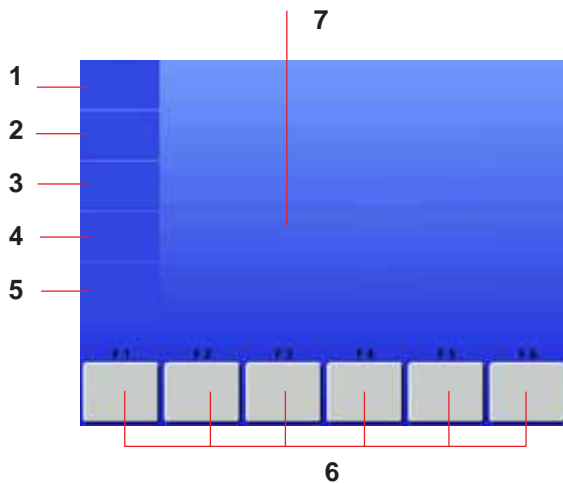

Figure 8

Detailed description of display fields

The screen is subdivided into various display fields, each of which is associated with a certain type of information.

Information fields

- 1 Number of the installed program version
Machine name
Date and time
- 2 Selected Menu name
- 3 Selected profiling mode
- 4 Electrical compensation
- 5 Error codes

6 Menu fields

Icons illustrating special features or functions are viewed in the six menu fields. Under every menu field is the associated menu "F key" which is used to call the feature illustrated.

7 Display field

Wheel type and rim dimensions
Balancing modes
Amount of unbalance
Direction of orientation and correction position
Function and Setup Menus

3.2 Menu Keys

3.2.1 Description of Menu Keys

The assignment of the menu keys **F1** to **F6** is shown in the menu fields above the relative keys on the screen. The menu keys have different functions and initiate different actions, depending on the program step.

- Keys without a symbol in the upper right-hand corner or at the edge initiate an action immediately, such as F2 on the main screen means to perform a compensation process. See Figure 9.

- Keys with one or more symbols in the upper right-hand corner of the menu field or at the edges initiate various actions:

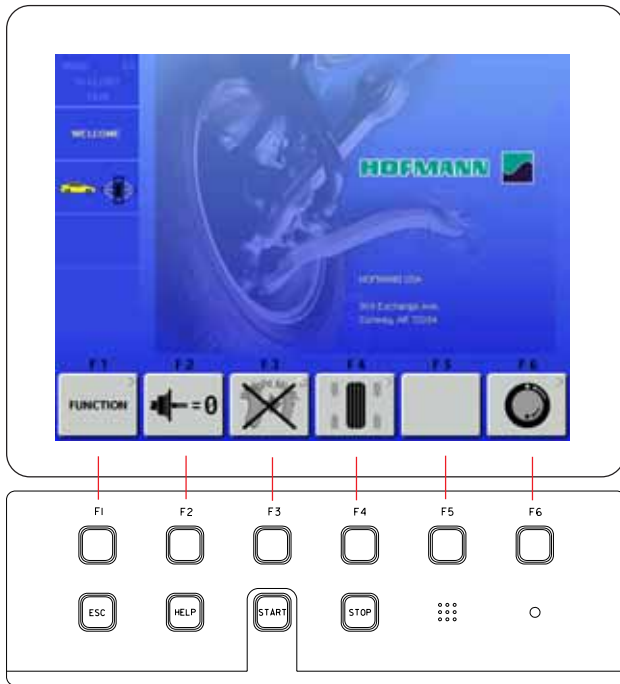

Figure 9

a - Press key to access a sub-menu, e.g. key F4 Balancing.

b - Press and hold key down while rotating wheel at same time, e.g. key F11 Number of spokes.

c - Press key to toggle between two options or states, e.g. key F9 Static / dynamic unbalance.

d - Press key to toggle between several options or states, e.g. key F21 Weight position for correction plane.

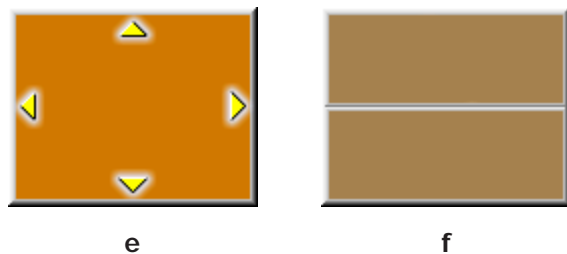

e - Toggle switch (4 functions): Press edge of key to carry out the highlighted action, e.g. key F32 Character set: move the cursor in the character set to the left, to the right, up or down.

f - Toggle switch (2 functions): Press key on top or bottom to select the highlighted function, e.g. key F8 Precision reading of unbalance and mode select.

3.2.2 MAIN MENU FUNCTIONS



Icon 1

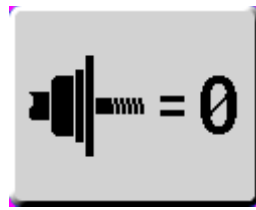

Icon 2

Icon 1 Change to the Function screen

Icon 2 Perform adapter compensation run

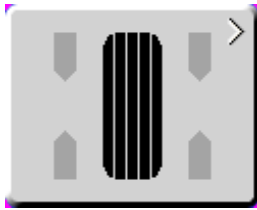

Icon 3

Icon 3 Change to the Balancing screen

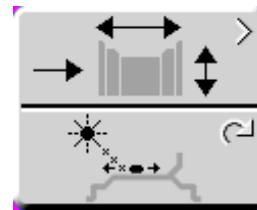

Icon 5



Icon 6

Icon 5 Toggle switch, two functions:

Pressed on top:
View and/or edit Data Input (wheel parameters)

Pressed on bottom:
Move the laser position pointer to the desired location. Button must be held down as the shaft is rotated. (only when stick-on weights are selected)



Icon 7a



Icon 7b

Icon 6 Toggle switch, two functions; reading only as long as the key is pressed (quick reading):

Pressed on top:
Precision reading of unbalance, no suppression of minor unbalance readings.

Pressed on bottom:
Toggles through possible placement locations of weight placement for conventional balancing run.



Icon 8



Icon 9

Icons 7a and 7b Select static unbalance or Select dynamic unbalance

Icon 8 Number of spokes has been selected and entered.

Icon 9 Number of spokes has not been detected.

1. Press and hold F5 and turn the wheel to enter the number of spokes.
2. Release F5 when the right number of spokes is indicated.
3. Turn the wheel in the way that one spoke is located on the 12 o'clock position.
4. Press F5 and the balancer will split the weight into 2 pieces.
5. Place the weights behind the spokes.



Icon 10

Icon 10 Wheel with 6 spokes selected



Icon 11

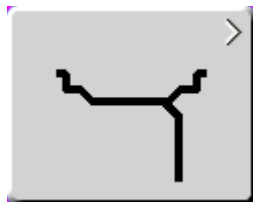

Icon 12

3.2.4 RIM DATA INPUT

Icon 11 Change to the WEIGHT PLACEMENT (mode) screen.

Icon 12 Change to the RIM TYPE screen



Icon 13



Icon 14

Icon 13 Hold key down and enter the distance rim/ machine by rotating the wheel

Icon 14 Hold key down and enter the rim width by rotating the wheel



Icon 15

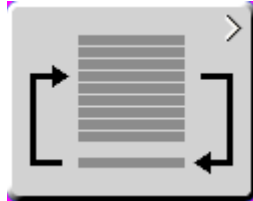

Icon 16

Icon 15 Hold key down and enter rim diameter by rotating the wheel

Icon 16 Change to the Stored Parameter menu. Must be in the "Manual" parameter mode

3.2.5 PROFILES SCREEN, STORED PARAMETERS



Icon 17

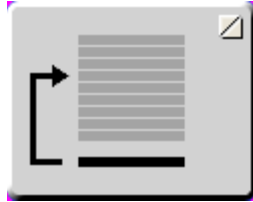

Icon 18

Icon 17 Select or store a wheel profile. Hold key down and select copy or store by rotating the wheel.

Icon 18 Store a parameter. Select memory location to store current wheel profile for later retrieval (yellow arrow). Select "OK" to enter the values currently in use to a stored location.



Icon 19



Icon 20

Icon 19 Copy a stored parameter. Select memory location for retrieval (yellow arrow). Select "OK" to enter the values stored for use in the next balance run.

Icon 20 Accept or enter the selected parameters.

3.2.6 FUNCTION MENU



Icon 21

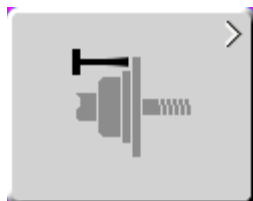

Icon 22

Icon 21 From the Main Menu, Select FUNCTION to access screens used to prepare the unit for desired operation.

Icon 22 Change to the screen USER CALIBRATION, see Maintenance chapter for user calibration procedures.

3.2.7 TEXT EDITOR

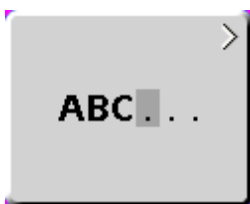

Icon 23

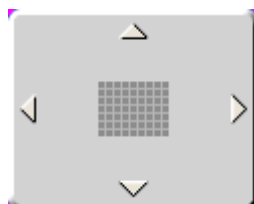

Icon 24

Icon 23 Change to the screen TEXT EDITOR

Icon 24 Toggle key, four functions: Move the cursor within the character set (right, left, up, down) to the desired character.

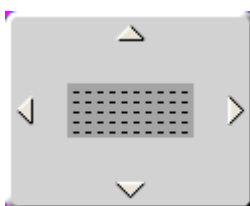

Icon 25

Icon 25 Toggle key, four functions: Move the cursor within the text field (right, left, up, down) to the desired text box location

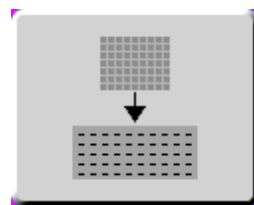

Icon 26

Icon 26 Transfer characters from the character set to the text field

Icon 27 Save text



Icon 27

3.2.8 FUNCTION (SETUP)

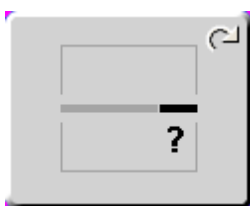

Icon 28

Icon 28 Change selected topic to desired value or function.



Icon 29

Icon 29 Hold button and rotate the wheel to scroll up or down to the desired line item.

Setup screen illustration. When desired features have been selected, save to permanent memory by selecting line item "3", Save to Permanent memory, enter a value of "1" with the F5 button while rotating the shaft. Release button to save. Select the "ESC" button to return to the main screen. See Figure 10.

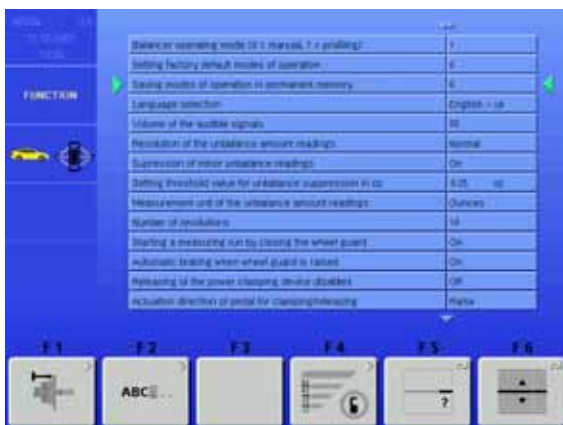

Figure 10

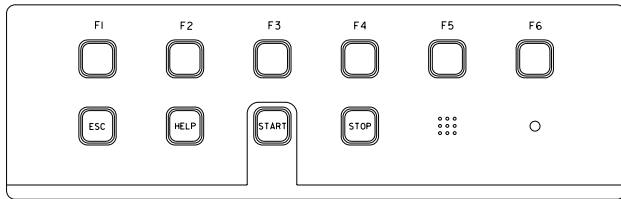

Figure 11

4.0 Help information

Help information explains the current action and, in the case of an error code, provides hints for remedy. See Figure 11.

Display help information

- Press the HELP key (See Figure 12)

The first screen with help information appears, e. g. to the screen RIM DATA INPUT.

- Press the HELP key once more to display any additional screen with information.

Quit help information

- Press the ESC key



Figure 12

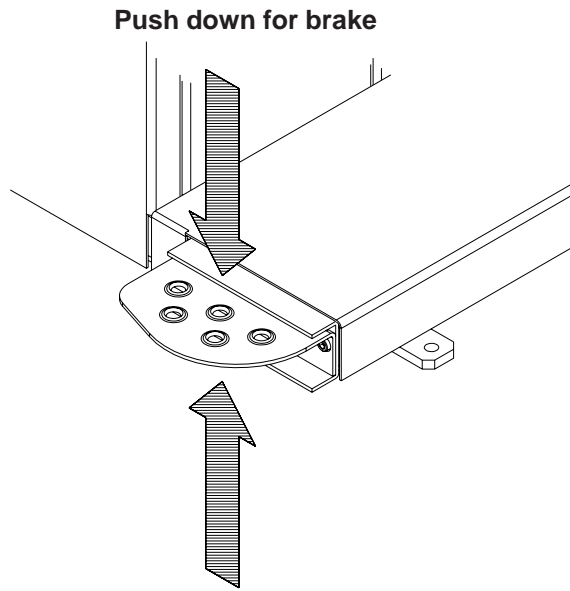

Lift up for power clamp operation
Figure 13

5.0 POWER CLAMP

5.1 POWER CLAMP PEDAL

Shaft Lock

The main shaft is locked when the pedal is **depressed**. This holds the wheel in the correction position for correct fitting of the correction weights. See Figure 13.

This lock is designed only to facilitate orientation of the wheel and must not be used for braking the main shaft.

Power Clamp Operation.

Lift upward to engage the power clamp jaws when the lock nut is placed on the shaft.

Lift upward again to release the clamp nut.

NOTE: The first time the unit is operated after power-up, make sure the power clamp engaging jaws are in the outer most position and ready for use. An Error of "E14" may result if the unit cannot accurately determine the clamping jaw position. Simple press "ESC" to continue, lift the pedal again to cycle and the power clamp will learn its new position. See Figures 14 and 15.

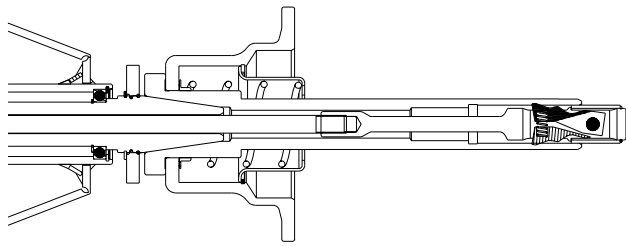

Power Clamp with jaws all the way OUT

Figure 14

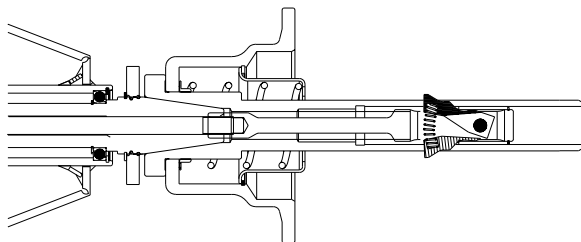

Power Clamp with jaws all the way IN

Figure 15



SEVERE PERSONAL INJURY WILL OCCUR IF FINGERS OR HAND IS PINCHED BETWEEN THE NUT, WHEEL OR FLANGE

6.0 OPERATION OF THE BALANCER

WARNING: For operator safety please read and follow the precautions outlined on pages 1 and 2 of this manual.

NOTE: READ ALL INSTRUCTIONS BEFORE PROCEEDING WITH OPERATION OF THE BALANCER.

All balancer functions are input into the main computer through the large easy to read touch panel. Although each wheel tire assembly differ in some ways all balancing jobs require basically the same procedure. The order of events to take place are:

1. Inspection of the wheel/tire assembly
2. Mounting wheel onto shaft
3. Scanner entry of wheel profile
4. Applying the recommended weight
5. Check spin if desired
6. Dismounting the wheel

The following operation instructions will follow the basic outline above.

6.1 CHECK LIST - INSPECTION

Observe Before Balancing Wheel

1. Check for proper air pressure. If not correct, inflate to correct pressure.
2. Check for any foreign material inside tire. If present, remove before balancing tire.
WATER IS FOREIGN MATERIAL!
3. Remove old weights — old weights may be improper value or in wrong location.
4. Be sure tire and wheel are free of excessive dirt, rust and large stones. Use wire brush on back side of wheel if necessary.

Figure 16



5. From the main menu, see Figure 16 above, select the desired process
F1. Function - setup the balancers parameters to perform in a certain fashion
F2. Compensate a wheel adapter
F3. Select to operate in the "Weight Miser™" mode or not
F4. Go to the balance process - normal selection for most users
F5. Not Used
F6. Optima - optimization process

6.2 BALANCE SCREEN DESCRIPTION

Refer to Figure 17a below for an example of a typical balance screen. The wheel displayed has been profiled as a rim which will accept a clip weight on the left side and a stick-on weight on the right side. The Clip weight will be placed at top dead center when the arrows indicate green. The stick-on weight is placed as indicated by the laser pointer. The operator selects the desired mode as indicated by the yellow weight icons, such as clip-stick as shown in the example below. Subsequent wheels will use the same mode until a different profile or parameter is detected.

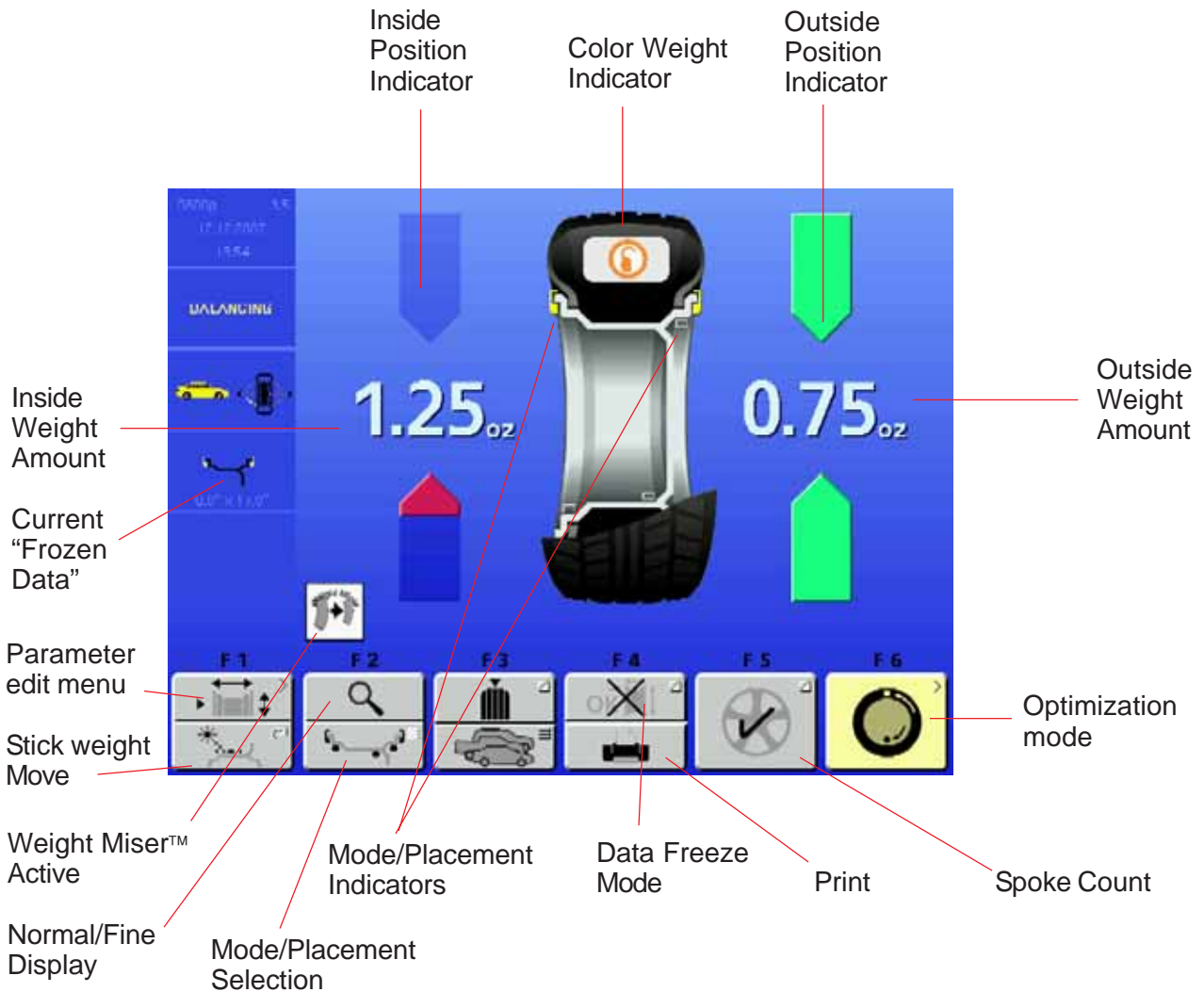

Figure 17a



Figure 17b - Color Weight Selections

Begin Balance procedures

From the Main Menu, select "F4" to enter the balance mode of operation.



6.2.1 WHEEL MOUNTING

Most standard wheels and many alloy wheels have accurately machined center holes, and they should be mounted with center cones. Accurate balancing depends on accurate mounting of the wheel and correct seating of the cone in the pilot hole. Insure that the wheel is centered on the shaft exactly as it will be mounted to the vehicle.

Before starting any balancing procedure it is very important that the wheel is mounted on the machine with the proper adaptors. An incorrect centering of the wheel will result in considerable imbalance.

There are many types of wheels and Hofmann supplies adaptors of high quality and durability for the large majority. However if you meet special wheels which may require a specific adaptor, call your authorized Hofmann distributor.

Rims may be divided into these major groups:

1. *Car rims with a true center hole.*
2. *Car rims without a center hole.*
3. *Car rims with an untrue center hole.*
4. *Light truck rims.*

6.2.2 STANDARD WHEELS (BACK CONE MOUNT)

Mount the wheel as detailed below in Figure 18a.

1. Mount proper cone against spring plate.
2. Mount wheel on shaft in the same manner as you would on the car.
3. Mount the Power Clamp nut along with proper pressure cup.
4. To operate the power clamp, lift the foot pedal to engage the clamp. Lift pedal again to release the nut.

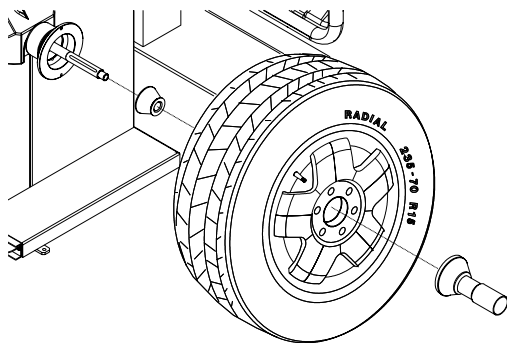

Figure 18a - Standard rear cone mount

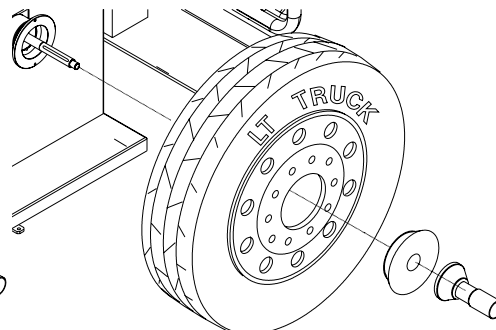

Figure 18b - Truck cone - outside cone mount

6.2.3 CENTERING LIGHT-TRUCK WHEELS

Install the wheel, using the front cone method, See Figure 18b.

An optional offset spacer may be required for some light truck wheels and reverse-offset wheels that must be moved away from the balancer mounting flange. The extension adaptor is often used with the 5-1/4 inch diameter light truck cone.



WARNING - HOLD THE POWER CLAMP NUT BY THE PLASTIC END CAP ONLY!! THE POWER CLAMP WILL NOT STOP UNTIL THE WHEEL IS SECURE AGAINST THE FLANGE. SEVERE PERSONAL INJURY WILL OCCUR IF FINGERS OR HAND IS PINCHED BETWEEN THE NUT, WHEEL OR FLANGE.



6.3 SCAN MODE SELECTION

The 9600P can be operated in 2 modes, Automatic Profiling and Manual Mode. Default factory setting is the Profiling mode.

PROFILING mode features fully automatic rim profile and parameter entry including:

- Rim profiling to get rim data including ALU wheel weight position
- Spoke count when ALU mode is detected
- Balancing



The PROFILING mode is indicated by the following symbol that is visible in information box 3 in the left upper corner of the screen.

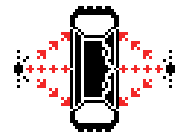

MANUAL PARAMETER ENTRY MODE - Read the rim diameter marked on the sidewall of the tire (Figure 19). Enter the rim parameters manually by pressing the parameter button twice then holding while rotating the wheel assembly until the desired value is displayed. Repeat for desired values for Distance, Width and Diameter. See Figure 20.

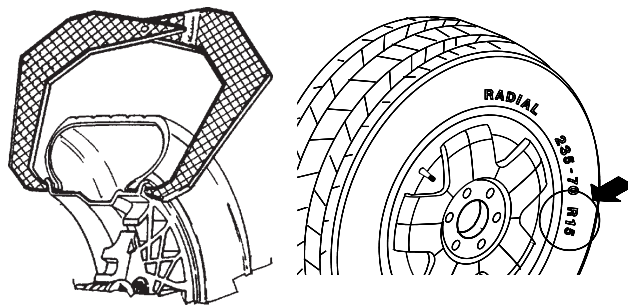

Figure 19



Figure 20

6.3.1 DATA FREEZE MODE

After spinning the first wheel of a multiple set of wheels, Press F6 in the Parameter Screen to “Freeze” or store the wheel data. The Data Freeze feature is accessed by selecting the top part of F4 on the Placement Screen. This time saving feature allows subsequent wheels of like style and size to be balanced without taking the time to Profile the wheel. Simply press F9 again to service wheels that require a new profile.

6.4 SPINNING THE WHEEL

CAUTION: Before spinning the wheel, make sure proper eye protection is worn by all personnel in the vicinity of the balancer.

Spin the wheel by lowering the wheel guard. If auto-spin is not activated press “Start” to begin balancer run. When the balancing cycle is complete the wheel will stop automatically and the imbalance values will appear on the screen.

In the Profiling Mode, the profilers automatically measure the rim distance, rim width, wheel diameter and measures the amount of imbalance. Spokes are counted as well. The rim edge is analyzed for selecting the type of weight to be used.



The 9600P then displays the correction screen for weight placement.

6.5 SELECTING THE WEIGHT PLACEMENT



Figure 21

A. 2-Plane - Choose the appropriate balancing mode for the wheel. To select the various 2-plane weight placement modes press the Mode button (Lower part of F2) until the placement graphic indicates desired corrective weight placement position. Press and hold the lower button for 3 seconds goes directly to clip-clip without having to prompt through all the modes. Fig 21

B. STATIC mode. Use a single corrective weight placed in the center or inner edge of rim. Select Static by pressing the “F3” key on the balancing screen. Pressing “F3” again will toggle operation back to Dynamic 2-plane operation.

NOTE: If in the “clip-weight static mode”, the weight placement position will be at top dead center. While in “stick-on mode”, weights will be placed at bottom center where the laser indicates.

6.6 CORRECTION OF THE IMBALANCE

A. The wheel assembly automatically stops near the right weight correction plane.

NOTE: Automatic plane braking can be selected from the Main Function Setup Menu. Factory default is right plane (2), select a value of “1” for braking on the left plane, “0” for none.

B. Read the imbalance value of the right side. Values are displayed in ounces but can be displayed in grams if required and are automatically rounded to the nearest commercial wheel weight.

C. Place the amount of weight called for. Use the foot operated shaft lock to stabilize the shaft during weight placement if required.

D. Press “Start” with the hood up to rotate the assembly to the left or inner correction plane.

E. Place the amount of weight called for. Use the foot operated shaft lock to stabilize the shaft during weight placement if required.

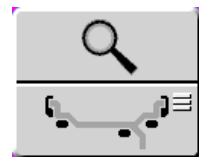

F2

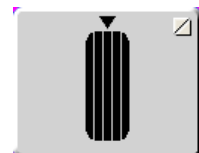

Static

NOTE: If a check spin reading does not “ZERO”, check for proper wheel mounting, weight placement, worn or damaged mounting accessories, or water in the tire etc.

PROCEDURE WHEN SCANNER FAILS TO ACQUIRE A VALID PROFILE

If data for distance, diameter or width are missing it is not possible to balance a wheel since the balancer does not have proper wheel data.



The unit will display the data (distance / diameter / width and weight placement mode) of the last valid wheel measured in RED color to indicate those data fields which might not be correct.

In the event of chasing weights, view the “Parameter” Screen and observe the values. If any parameter is displayed in red, it has not been validated and the value must be manually entered to recalculate the proper correction values. To change a value in the Parameter or Optima mode, the corresponding button must be depressed twice. Modify the data by pushing and holding F3, F4 or F5 and turning the wheel until the desired value is displayed.

After the wheel has been unclamped from the balancer, the balancer will switch back to the previous mode for the next wheel assembly.

6.7 VERIFICATION OF THE RESULTS

Lower the wheel guard to spin the wheel again and check that the readout is “0.00” “0.00” If a residual imbalance is displayed: Reference Graphic 1 next page for diagnostics explanation below.

NOTE: Make sure the intended balance mode is selected, If Weight Miser™ is selected a small amount of residual un-balance is expected. If the balance requires further attention, disable the Weight Miser™ mode

- A. Check the rim parameters, if entered value is incorrect, correct as needed. Imbalance values will be automatically re-computed.
- B. Check if the balancing mode selected is the most appropriate. If not, choose the right mode and re-spin.
- C. The wheel weight could have been placed at a wrong position. To check this, position the wheel at the correction position for the outer plane. If the wheel weight previously attached is in sector ‘L’ or ‘R’ (Graphic 1, page 20), move the wheel weight up about 1” (2.54cm).

If the wheel weight is in sector ‘D’ cut a piece of the wheel weight of an approximate value corresponding to the value shown on the right display, or replace the wheel weight with a lighter one.

If the wheel weight is in sector ‘U’ add a weight of value indicated by the display or replace the wheel weight with a heavier one. Repeat the same operation for the inner plane.

NOTE: If this situation is repeated, your machine may be out of calibration and a calibration operation might be required, contact a service representative for re-calibration.

D. If an ALU function was selected ensure the wheel weights have been placed in accordance to the program chosen.

E. Check that the wheel is not slipping against the backing collar.

F. Check that the wheel and adaptors are clean.

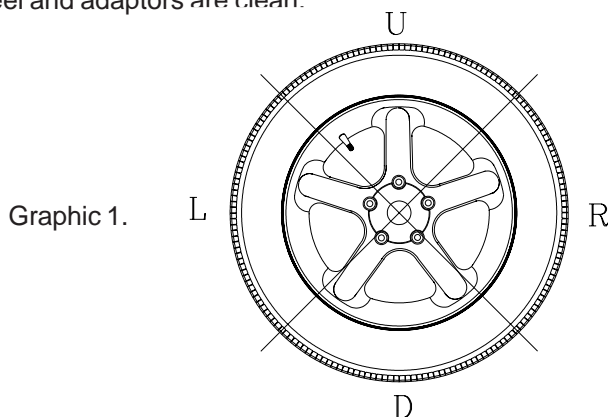

6.8 VIBRATION PROBLEMS

If vibration is still present after balancing, check the following possible sources of vibration:

1. Stones caught in the tire tread.
2. Tire slippage on the wheel.
3. Incorrectly mounted wheel.
4. Imbalanced wheel covers.
5. Excessive radial or lateral runout in the tire or wheel.
6. Damaged wheel bolt holes.
7. Worn universal joints.
8. Imbalanced brake rotors or drums.
9. Worn or damaged balancer accessories.

7.0 SPOKE BALANCING MODE

A standard dynamic balance in ALU mode places compensation weight in two planes, inner and outer, at the bottom dead center for each plane of calculated imbalance. Sometimes the outside weight placement may be unsightly on a custom wheel. The Spoke Mode is designed to “hide” outer plane corrective weight by placing the required weight behind selected spokes in order to retain the esthetic appeal of the wheel.

1. Press the Spoke button, F5.
2. Outer weights will be divided. Weights may not be equal depending on the spoke positions relative to the imbalance position.
3. Place stick-on weights where indicated by the laser pointer.
4. Perform a check spin if desired.

NOTE: *Stick-on weight position can be “tweaked” by depressing the lower part of “F1” while rotating the shaft fore or aft until the laser locates in the desired position. Inner or Outer placement indicator must be “in the green” before depressing the button.*

9.0 WEIGHT MANAGEMENT

INTRODUCTION - The 9600P Weight Management Software features consist a unique program designed to maximize the tire shops profits while maintaining efficiency. **Weight Wizard™** works to reduce weight costs, and minimize excessive weight inventory. Weight inventory can be tailored by location requirements to avoid waste.

Weight Wizard™

Weight Wizard™ is a Patented method using a precision laser to determine the required clip weight type for the rim profile being serviced. The laser can also determine use of stick on weights and precisely place them for maximum performance. As wheel weights are changing from lead to steel due to environmental and health concerns and the cost of wheel weights increasing with the change. Customers can now purchase wheel weights in quantity with regard to weight type and weight amount. This will allow shops to avoid accumulating large quantities of unused wheel weights which are expensive to purchase and difficult to store.



Viewing the Weight Wizard™ Data File:

From the Main Menu – select the F1 “Function Key”, from the Function Menu screen select the F4 Key to display the Weight Management screen. See Figure 37.

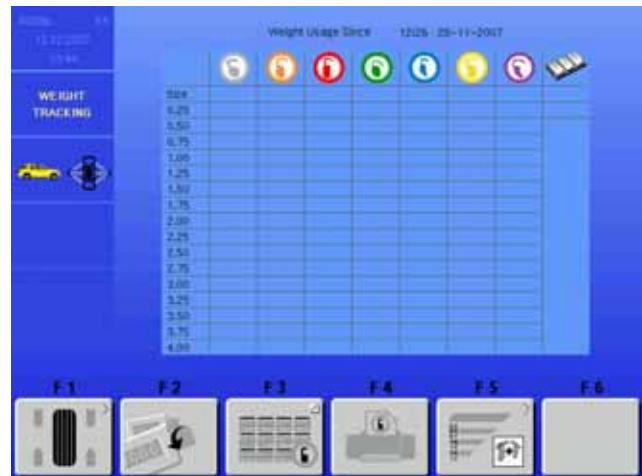

Figure 37

Weight Wizard™ Features:

- ⊗ Weight Wizard™ indicates both what type of weight and weight sizes that are actually being used.
- ⊗ Knowing the most popular usage, the buyer can tailor the weight purchasing requirements by location and avoid excessive expense and waste.
- ⊗ The time and date of the tracking file is displayed across the top of the screen.
- ⊗ Weight amounts in quarter ounce increments are listed from one quarter ounce through four ounces on the left hand side.
- ⊗ Both an “Acumulated” and “Since this Date” counts are available by toggling “F3”. The “Since” values are reset by selecting “F2”. The Accumulated values must be reset by formatting via the Function Menu.
- ⊗ If tape on weight is used, the amount of tape on weight is also stored.
- ⊗ Weight amount and type is determined automatically by the wheel balancer.
- ⊗ Upon un-clamping of the wheel, the weight type and weight amount is written to this file.



Figure 38

Weight Miser™ - 9.1

Weight Miser™ is a software program that determines if there is the possibility to remove sufficient vibration from a tire and wheel assembly by applying a lower amount of weight than the normal balance function recommends. The amount of residual imbalance left on the tire and wheel assembly is determined by the residual threshold tolerance setting.



Figure 39

Assuming that an amount of residual imbalance accepted nowadays by the automotive industry standards is 5 grams for static imbalance and 10 grams for dynamic imbalance, a new feature *Weight Miser* allows the tire shop to achieve wheel balancing using less – smaller – balancing weights.

It must be very clear that the feature works assuming that some residual imbalance can be left on the wheel. The tire shop will save weight, but wheels will be balanced with a lower degree of accuracy.



Weight Miser™ is enabled

The feature – *Weight Miser™* – is disabled by default when the unit is manufactured. The machine will leave the factory in its original high-accuracy balancing configuration.



Figure 40

The user has the option to activate the feature from the “*Main Menu*”. See Figure 40. Press the “F3” key to activate *Weight Miser*. The feature is activated when the green icon with the “X” is shown at the “F3” position as shown.



Disabled

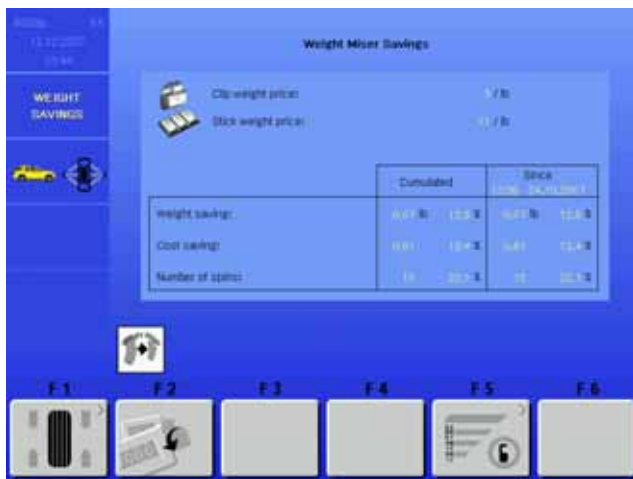

Figure 41

When in the Weight Miser™ mode, software determines if a single weight approach is feasible. If it is possible to reduce both static and dynamic imbalance below the given thresholds using a single weight, then a single weight will be recommended. If not, two-weight balancing will be recommended, but the weight amounts can be lower.

There are five entries in the “**Function Menu**” for Weight Miser™ setup. See Figure 42.

1. Weight Miser™ feature enable – ON/OFF (Function default is OFF)
2. Weight Miser™ static threshold
3. Weight Miser™ dynamic threshold
4. Clip weight to money conversion
5. Stick weight to money conversion

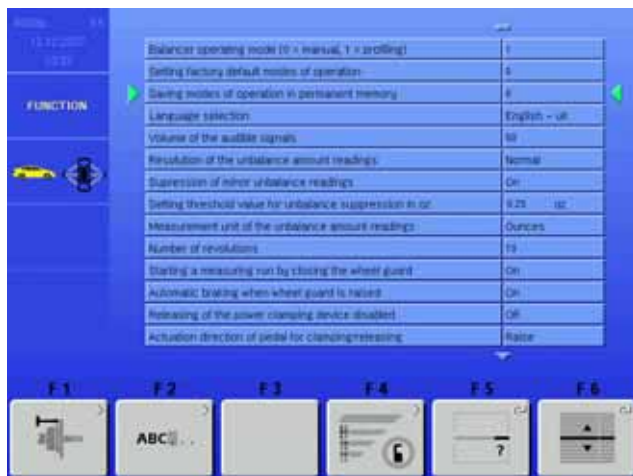

Figure 42

The two thresholds for Weight Miser™ are adjustable. There is a recommended pre-set limiter.

The Weight Miser™ thresholds can be set in the set up function screen as described. Furthermore, a quick way to change thresholds is the vehicle type selection.

For the vehicle category – SUV and Truck, there is a multiplier that increases the threshold from the preset **CAR** values due to the fact that these vehicle types can tolerate a higher residual imbalance. See Figure 43.



Figure 43

<u>Vehicle type</u>	<u>Threshold</u>
Passenger Car	1x
Motorcycle	1x
SUV	1.5x
Light Truck	2x

The weight to money conversions are adjustable to display the approximate amount of money savings relative to the weight savings. The user can change the value of conversion depending upon his weight purchase costs

To observe the Weight Miser™ screen as shown in Figure 41, press the F5 button when in the Weight Wizard™ screen.



Figure 22

8.0 Optimisation Procedures

1. Optimisation is a tire - rim matching procedure used to minimize placed weight. This matching procedure can also minimize radial runout in many cases where the runout high point is associated with the measured heavy point. The Optimisation procedure can begin with a bare rim or by starting with a tire/rim assembly.

Select softkey "F6" to continue to the matching process. See Figure 22.

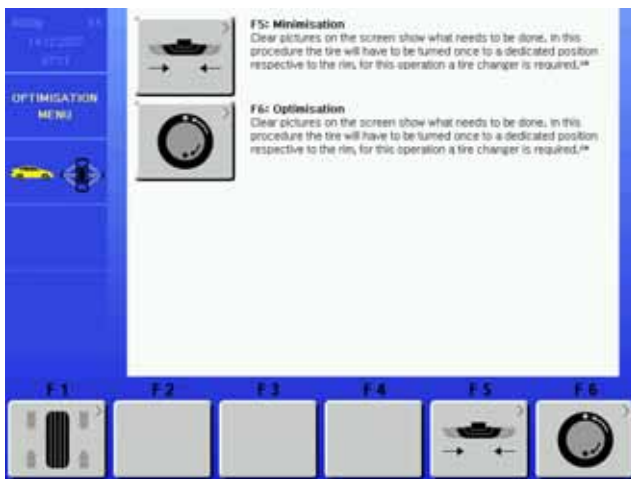

Figure 23

2. From the Screen displayed in Figure 23, select "F5" to begin matching a tire/rim assembly, select "F6" to begin the matching process with a bare rim.

The example procedure shown will select a tire/rim assembly.



Figure 24

3. Rotate the assembly so the valve stem is located at top dead center. Press "F6", to continue. See Figure 24.



Figure 25

4. Press the "Start" button to begin a measure run. See Figure 25.

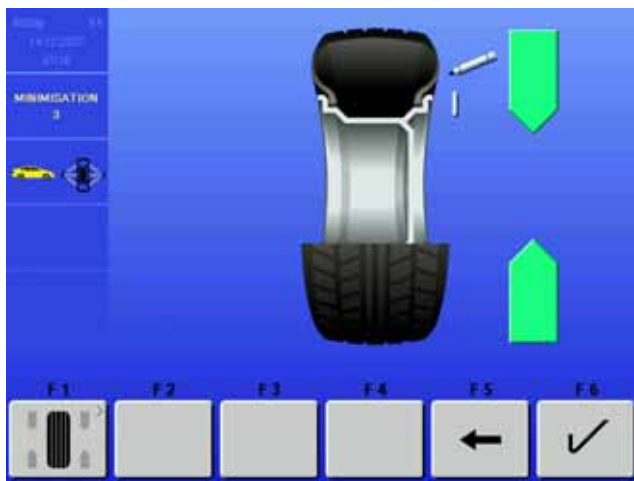

Figure 26

5. Rotate the assembly so the arrows are both GREEN, as shown in Figure 2. Mark the tire at top dead center. Select "F6" to continue.



Figure 27

6. Remove the Wheel assembly from the balancer and break the bead using a tire changer. Rotate the tire on the rim so the mark and valve stem are lined up. See Figure 30. Select "F6" to continue.

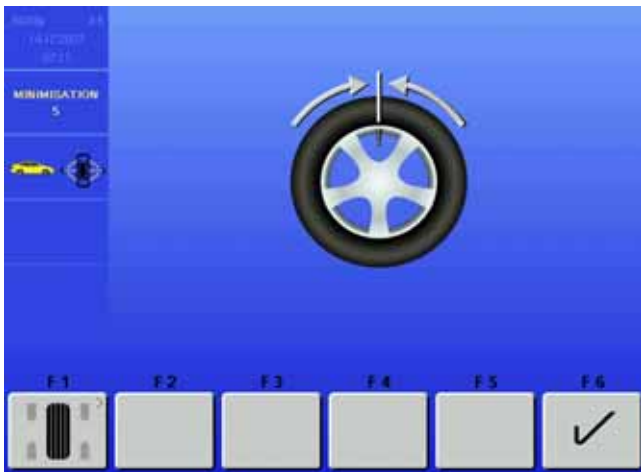

Figure 28

7. Reinflate the tire to specifications.

Mount the assembly back onto the balancer as before.

Rotate the tire/rim assembly so the mark-valve stem is straight up, or at the 12:00 o'clock position. See Figure 28. Press "F6" to continue.



Figure 29

8. Select "Start" See Figure 29.

The unit will re-profile and recalculate based on the new tire-rim combination.

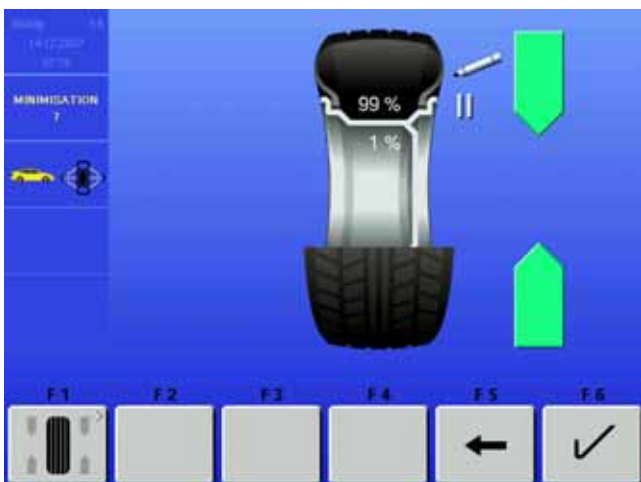

Figure 30

9. Rotate the assembly until the arrows turn Green as shown in Figure 30. Mark the tire with two (2) marks.

Select "F6" to continue.



Figure 32

10. Remove the tire/rim assembly from the balancer and break the bead using a tire changer. Rotate the tire on the rim so the double mark and valve stem are lined up. See Figure 32.



Figure 33

11. Reinflate the tire to specifications.
Mount the assembly back onto the balancer as before.
Rotate the tire/rim assembly so the mark-valve stem is straight up, or at the 12:00 o'clock position. See Figure 33. Press "F6" to continue.



Figure 34

12. Select "Start" See Figure 34.
The unit will re-profile and recalculate based on the new tire-rim combination.



Figure 35

13. If the match procedure was successful an “OK” will be displayed as shown in Figure 35.

Press “F6” to continue to the balance screen for weight placement.



Figure 36

14. Corrective weight amounts and locations will be displayed. See Figure 36.

10.0 USER CALIBRATION

The Hofmann 9600P Balancer features a user calibration program which requires only a few minutes to complete. Perform this procedure when the balancer has been moved, disturbed, or whenever accuracy is questioned. Occasional field calibration will ensure years of reliable service.

Follow these 3 simple steps for shaft calibration:

1. Press and release the **“Function”** key (F1) from the **“Welcome or Main Screen”**.
2. Press and release the **“Calibration”** key (F1). Fig 43.

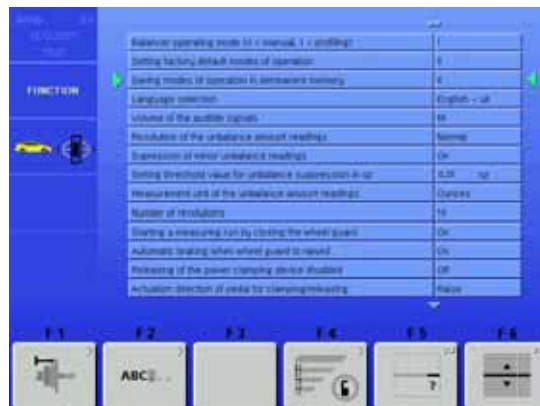

Figure 43

3. Place 2 cones followed by the clamping nut (no retainer) onto the shaft. Lift the pedal to clamp. See Figure 44.

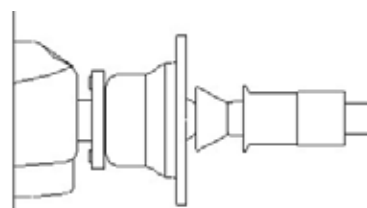

Figure 44 - 2 cones & clamping nut only

4. Lower the wheel guard and press the **“SPIN”** key. The balancer should spin and come to a complete stop. See Figure 45.



Figure 45

4. After the balancer comes to a stop raise the wheel guard and screw the calibration slug into left side of the flange plate. Lower the wheel guard and press the **“SPIN”** key. The balancer should spin and come to a complete stop. Once the shaft stops the display should display **“OK”** and the speaker sounds the **“TüDüLü”**. See Figure 46.



Figure 46

SHAFT CALIBRATION IS COMPLETE

11.0 EXPLANATION OF PROGRAM CODES

In the event of damage or malfunction, a code may be displayed indicating the area or location of the detected error. These codes are important to the service agent when he services the unit. Note any codes or error messages before calling for service or assistance.

- 1. Communication between micro-controller and embedded PC (Blue screen)**
Service Codes: No service code available Communication between micro-controller and embedded PC is not OK (check connecting cable). This can also indicate a bad connection to the keyboard.
- 2. Check availability of keyboard (E 300)**
Service Codes : No service code available The microcontroller was not able to detect a keyboard. Check cabling between microcontroller and keyboard.
- 5. Check keyboard (E 89)**
One of the keys F1 to F6, HELP, ESC, START supplies a "Stuck key" code. The machine will proceed with the next step only if the trouble is remedied.
- 6. Check pedal switches (E 89)**
Press STOP or ESC key to check the pedal switch once to delete the error code reading. If the trouble cannot be remedied, the pedal is made inoperative.
- 7. Check 9600P Calibration (E 360)**
The optima hardware requires wheel profiler position calibration.
When the camera controller board is replaced on the machine, the SW detected that calibration data is missing. A Service Calibration procedure is required to calibrate the actual position of the laser scanners with respect to the balancer reference plane. Contact a Service Representative.
- 8. Check 9600P Hardware (E 361)**
Wheel profiler is not present or responding during the self test. The balancer controller board was not able to communicate with the camera controller board during startup test.
Possible causes:
 - The camera controller board is missing or dead.
 - The cable connecting the balancer controller board and the camera controller board is unplugged, damaged or missing.
- 9. Check 9600P Hardware (E 362)**
Service Codes : All codes available for this model
Main camera board self test failed.
Balancing is not possible since wheel data cannot be scanned.
Problem during power up. Switch power off and on again. Possible camera board failure.
- 10. Check 9600P Inner Scanner (E 363)**
Service Codes : All codes available for this model
Left side scanner self test failed or CCD not calibrated or zero mark not detected.
Balancing is not possible since wheel data cannot be scanned.



11. Power clamp service interval expired E93

12. Hardware test disturbed H 82

A. Hardware test -common errors

C10F02 -Test returned with an error. No valid test results available

C10F07-Test function reported an unkown error

C10F18-Test timed out. No valid test results available

B. Hardware test -Power supply voltage

C10800

C10801

C10804

If the line voltage is below or above a limit the error code is displayed.

C. Hardware test -5V line

C10810

C10811

If the 5V voltage is below or above a limit the error code is displayed.

D. Hardware test -Current of optoelectronic LED

C10705

C10706

C10707

C10708

If the current / voltage is below or above a limit the error code is displayed.

E. Hardware test -Transducer signals

C10410

C10420

C10430

Checks transimpedance and signal amplifiers and transducer values. If no signals from the transducers are detected the error code is displayed.

F. Hardware test -Auto stop system

C10380

C10381

C10382

C10383

Checks voltage on capacitor of the auto stop system.

If the voltage is below or above a limit or the recharging time is above a limit the error code is displayed.

12.0 MAINTENANCE

BEFORE ANY MAINTENANCE OR REPAIRS ARE ATTEMPTED THE MACHINE MUST BE DISCONNECTED FROM THE ELECTRIC SUPPLY.

This balancer does not require any special maintenance, but the following precautions are required:

- A. Periodically clean all plastic parts with a glass cleaner. Wipe with a dry cloth.
- B. Clean all adapters regularly with a nonflammable liquid detergent all. Lubricate with a thin layer of oil.
- C. Periodically perform a routine shaft calibration as outlined on page 24 of this manual.

13.0 TROUBLE SHOOTING

<u>TROUBLE</u>	<u>CAUSE</u>	<u>REMEDY</u>
When turning the machine on, the displays do not light	No electric power Defect in the electric/electronic system	Check the input voltage Call Hofmann service for assistance
The machine gives random readouts.	Machine unstable on the floor Water in the tire Loose adaptor Defective electronic board	Check that machine is stable Remove water from tire. Tighten the adaptor firmly Call Hofmann service for assistance
The machine does not stop after balancing cycle	Defective electronic component	Stop using the machine immediately and call Hofmann service for assistance
The balancer is slow to display when powering machine up.	This machine performs a self-test routine on start-up. There will be a delay of several seconds before the display is activated.	This is a normal characteristic of the machine
If the balancer ceases to properly measure parameter values	Malfunction of one of the scanners, A failure of the AWP system, or harness connection failure.	Call Hofmann service for assistance



Notes:

Operator's Manual
Covers Hofmann Model 9600P
EEWB723A
Software version 3.5

Copyright 2007 Snap-on Equipment Services
All rights reserved