

EEWH311A

Air/Electric Tire Changers

Operation Instructions

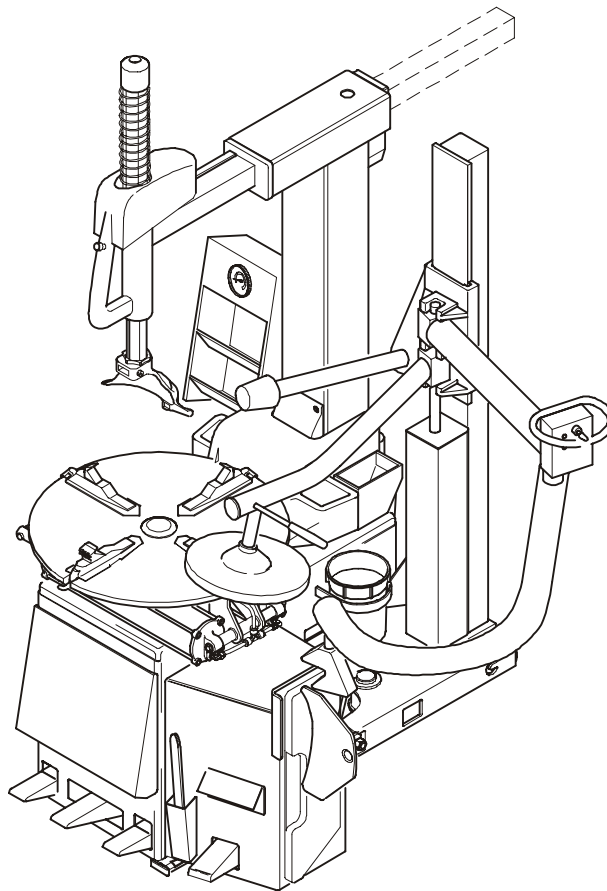

Snap-on®

FORM ZEEWHGB311A

(BLANK PAGE)

EEWH311A

Air/Electric Tire Changers Operation Instructions

COPYRIGHT NOTICE

The information contained in this document is property of Snap-on Incorporated. It, or any of the information contained within, shall not be used, copied, or reproduced without express written consent of Snap-on

TRADEMARK NOTICE

Snap-on® and Snap-on Incorporated are registered trademarks

Snap-on®

(BLANK PAGE)

SAFETY INFORMATION

**For your safety, read this manual thoroughly
before operating the EEWH311A Tire Changer**

The EEWH311A Tire Changer is intended for use by properly trained automotive technicians. The safety messages presented in this section and throughout the manual are reminders to the operator to exercise extreme care when changing tires with these products.

There are many variations in procedures, techniques, tools, and parts for changing tires, as well as the skill of the individual doing the work. Because of the vast number of wheel and tire applications and potential uses of the product, the manufacturer cannot possibly anticipate or provide advice or safety messages to cover every situation. It is the automotive technician's responsibility to be knowledgeable of the wheels and tires being changed. It is essential to use proper service methods and change tires in an appropriate and acceptable manner that does not endanger your safety, the safety of others in the work area or the equipment or vehicle being serviced.

It is assumed that, prior to using the EEWH311A Tire Changer, the operator has a thorough understanding of the wheels and tires being changed. In addition, it is assumed he has a thorough knowledge of the operation and safety features of the rack, lift, or floor jack being utilized, and has the proper hand and power tools necessary to service the vehicle in a safe manner.

Before using the EEWH311A Tire Changer, always refer to and follow the safety messages and service procedures provided by the manufacturers of the equipment being used and the vehicle being serviced.



IMPORTANT !!

SAVE THESE INSTRUCTIONS - DO NOT DISCARD !!

SAFETY INSTRUCTIONS

IMPORTANT!! SAVE THESE INSTRUCTIONS!!



Overinflated tires or tires mounted on the wrong sized rims can explode producing hazardous flying debris.

- **Read Operator's Manual before using this Tire Changer.**
- **Never mount tire on rim with different sized diameter.**
- **Never exceed maximum inflation pressure listed on tire sidewall.**
- **Always use safety restraint arm to hold wheel in place while inflating.**

- **Always use attached air hose to inflate tires.**

Exploding tires can cause death or serious injury.



Risk of electrical shock.

- **Do not operate equipment with a damaged power cord or if the equipment has been dropped or damaged, until it has been examined by a qualified service person.**
- **If an extension cord is necessary, a cord with a current rating equal to or greater than that of the equipment should be used. Cords rated for less current than the equipment can overheat.**
- **Unplug equipment from electrical outlet when not in use. Never use the cord to pull the plug from the outlet. Grasp plug and pull to disconnect.**
- **Do not expose the equipment to rain. Do not use on wet surfaces.**
- **Plug unit into correct power supply.**
- **Do not remove or bypass grounding pin.**

Contact with high voltages can cause death or serious injury.



Risk of electrical shock. High voltages are present within the base unit.

- **There are no user serviceable items within the unit.**
- **Service on the unit must be performed by qualified personnel.**
- **Do not open any part of the base cabinet.**
- **Unplug the unit before servicing.**

Contact with high voltages can cause death or serious injury.

Warning !



- Risk of crushing. Stand clear of bead breaker arm during operation.
- **Read and understand the operation instructions before using this tire chamer.**
 - **Become familiar with all controls before proceeding with operation.**
 - **Stand away from the bead breaker arm when in operation.**
 - **Apply air to breaker in bursts if necessary to control arm depth.**
 - **Keep all persons clear of tire chamer.**
- Contact with moving parts could cause injury.*

Warning !



- Risk of pinching or crushing hands and fingers when mounting and demounting.
- **Read and understand the operation instructions before using this tire chamer.**
 - **Keep hands and fingers clear of rim edge during demounting and mounting process.**
 - **Keep hands and fingers clear of mount/demount head during operation.**
 - **Keep hands and other body parts away from moving surfaces.**
 - **Do not use tools other than those supplied with tire chamer.**
 - **Do not bypass any safety features.**
 - **Use proper tire lubricant to prevent tire binding.**
- Contact with moving parts could cause injury.*



- Risk of eye injury. Flying debris, dirt, and fluids may be discharged during bead seating and inflation process.
- **Remove any debris from tire tread and wheel surfaces.**
 - **Remove excess tire lubricant before inflating.**
 - **Wear approved safety glasses during mount and demount procedures.**
- Debris, dirt, and fluids can cause serious eye injury.*



- Risk of injury. Tools may break or slip if improperly used or maintained.
- **Read and understand the operation instructions before using this tire chamer.**
 - **Use only the mount/demount tire tool supplied with the tire chamer.**
 - **Frequently inspect, clean, and lubricate (if recommended) where designated.**
 - **Follow procedures when instructed in this manual.**
- Tools that break or slip can cause injury.*

IMPORTANT !! SAVE THESE INSTRUCTIONS — DO NOT DISCARD !!

⚠ DANGER

Tires and rims that are not the same diameter are mismatched.

- **NEVER attempt to mount or inflate any tire and rim that are mismatched.**
- **ALWAYS check to see that tire and rim diameters are the same.**

A mismatched tire and rim could explode causing death or serious personal injury.

⚠ WARNING

Over-pressurized tires can explode causing flying debris.

- **Read and understand Operator's Manual before operating.**
- **Keep bystanders away from work area.**
- **ALWAYS wear Safety Goggles.**
- **ALWAYS check to see that tire and rim diameters are the same.**
- **NEVER attempt to mount or inflate any tire and rim with different diameters.**
- **Inspect tires. NEVER inflate tires that are damaged, rotten or worn.**
- **NEVER inflate 'Split Rim Wheels' on this tire changer or remove them and use only an approved safety inflation cage designed for this purpose.**
- **Lock turntable clamp on inside of rim before attempting to inflate tire.**
- **Use approved tire bead lubricant before removing or installing tire on rim.**
- **ALWAYS position the "Safety Restraint Arm" over the wheel to hold it to the turntable while inflating if so equipped.**
- **If a tire explodes on this tire changer, STOP using it until the "Safety Restraint Arm" has been replaced, which must be done even if no damage is seen.**
- **NEVER place head or body over a tire during inflation process.**
- **Use short bursts of air to seat tire beads. Check tire air pressure frequently. NEVER exceed tire manufacturer's pressure limits.**
- **NEVER attempt to bypass or alter the built-in air pressure limiter. Only inflate tire with air hose supplied with tire changer. NEVER use shop inflation hose to inflate a tire.**
- **Tire Changer must be anchored to concrete floor if equipped with a "Safety Restraint Arm".**

Exploding tires can cause serious injury.

TABLE OF CONTENTS

..... Safety Statements	Page 5 to 8
..... Table Of Contents	Page 9
1.0 Introduction	Page 10
1.1 Specifications And Features	Page 10
1.2 Nomenclature	Page 10
1.2.1 ... Turntable & Cabinet Features	Page 11
1.3 Machine Dimensions	Page 12
1.4 Standard Accessories	Page 12
1.5 Optional Accessories	Page 13
1.6 General Cautions	Page 13
2.0 Installation	Page 14
2.1 Electrical Installation	Page 14
2.2 Air Installation	Page 14
3.0 Controls	Page 15
4.0 Mounting And Demounting Precautions	Page 18
4.1 Demounting Tubeless Tires	Page 18
4.2 Mounting Tubeless Tires	Page 21
4.3 If the top tire bead is difficult to mount	Page 22
4.4 Inflation of Tubeless Tires	Page 22
5.0 Demounting Tube Type Tires	Page 23
5.1 Mounting Tube Type Tires	Page 23
5.2 Inflating Tube Type Tires	Page 24
5.3 Operating the Pneumatic Bead Assist	Page 25
5.4 Mounting And Demounting Motorcycles Tyres	Page 26
6.0 Maintenance	Page 27

1.0 INTRODUCTION

Congratulations on your purchase of the Snap-on EEWH311A air-electric tire changer. This tire changer is designed for ease of operation, safe handling of rims, reliability and speed. This combination of features means more profit and added versatility for your shop, enabling you to work with aluminum or magnesium alloy wheels with reduced risk of damage. With a minimum of maintenance and care your Snap-on EEWH311A Tire Changer will provide many years of trouble-free operation.

Please read this manual thoroughly before operating the unit. Instructions on use, maintenance and operational requirements of the machine are covered in this manual.

1.1 SPECIFICATIONS

Operation temperature range: +41/+122 F (+5/50C)

Air-Electric tire changers for car, light commercial vehicle and motorcycle tires designed for one-piece rims.

EEWH311A

- Rim diameter capacity: 10" to 24"
- with special jaws for motorcycle, motor-scooter/ATV wheels: 8" to 23"
- Rim Width Maximum: 14"
- Tire Diameter Maximum: 40"
- Bead Breaking Force: 3300 lbs. at 145 psi air supply
- Electric Requirements: 110V, 60Hz, 20 amp
- Air Requirements: 110 - 145 psi
- Shipping Weight: 351 pounds

1.2 NOMENCLATURE

Before installing and using the Snap-on EEWH311A Tire Changer it is suggested that you become familiar with the nomenclature of the machine's components.

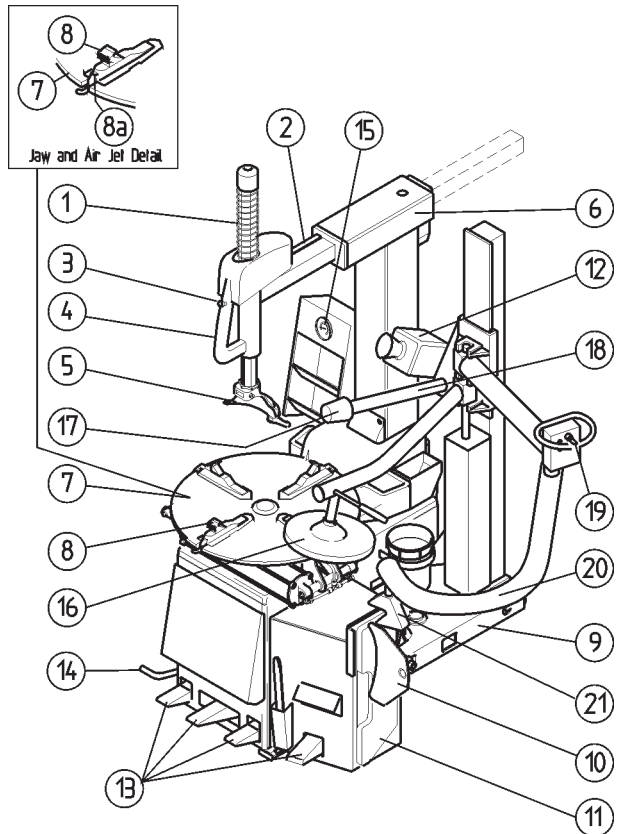

Figure 1.2-1

1103

- 1 Vertical Hex Shaft**
- 2 Swing Arm**
- 3 Lock button**
- 4 Handle**
- 5 Mount/Demount Tool or Head**
- 6 Tilting Tower or Column**
- 7 Turntable**
- 8 Clamping Jaws or Rim Clamps**
- 8a Inflation Jets**
- 9 Bead breaker arm**
- 10 Bead breaker blade**
- 11 Bead breaker pads**
- 12 Assembly Bottle**
- 13 Foot pedal controls**
- 14 Bead Seater/Inflator pedal**
- 15 Inflation gauge**

PNEUMATIC BEAD ASSIST (PBA)

- 16 Bottom Bead Roller**
- 17 Top Bead Roller**
- 18 Bead Assist Arm**
- 19 Rise/fall control lever**
- 20 Bead depressor arm**
- 21 Bead depressor tool**

1.2.1 TURNTABLE & CABINET FEATURES

EEWH311A

INTEGRATED BEAD SEATING JETS - Air inflation jets are integrated into the turntable clamping jaws to insure full bead seating force directly into the tire cavity regardless of tire diameter.

ADJUSTABLE BEAD BREAKER OPENING - Simple two-position bead breaker pin adjustment allows for readjusting breaker to fit larger OD tires.

TWIN CYLINDER CLAMPING POWER - Two 3" clamping cylinders provide uniform clamping pressure throughout the stroke (regardless of rim sizes) as well as providing 25% more clamping power than most single clamping cylinder tire changers. Additionally these two smaller cylinders reduce the critical turntable to cabinet distance, reducing the stress on the transmission.

WHEEL CLAMPS

UNIQUE SIX POINT CONTACT CLAMPS

Provide better gripping capability regardless of dirt and moisture.

REDUCED ANGLE CLAMPS

Increases clamping contact area with rim insuring no slippage.

NYLON INSERT SOFT TOUCH CLAMPS

Single sided nylon insert in the clamping jaws provides Nonmetal touch in critical customer visible areas.

VALVE CORE/TIRE TOOL STORAGE CABINET

On tire changer storage area for valves, tools, caulk, etc.

INCOMING AIR PRESSURE GAUGE

Ergonomically located air gauge allows easy operator monitoring of incoming air pressure.

INTEGRATED PRESSURE LIMITER

Integrated safety pressure limiter stops air flow once tire pressure has reached approximately. 55 PSI preventing accidental tire over-inflation.

MOUNT/DEMOUNT ARM ASSEMBLY

SURGE TANK IN THE TOWER - Space-saving design integrates the air storage surge tank in the tower allowing for flush to wall tire changer installation.

ADJUSTABLE SLIDEWAY - Unique adjustable vertical mount/demount hex shaft slideway allows for easy operator adjustment to compensate for any cumulative wear in the slideway causing mount/demount head movement.

NON-SCRATCH NYLON INSERT - Integrated into the mount/demount head is a replaceable scratch resistant nylon insert protecting against accidental rim contact.

CONSTRUCTION DESIGNED FOR DURABILITY

RUST PROOF VALVES AND CYLINDERS - Critical bead breaking cylinder is lined with rustproof polyfiber liner for years of rust free operation. Non-lined cylinders will pit causing bead breaker power loss.

LIFETIME LUBRICATED POLYMER VALVES - Critical footvalves fabricated from glass/fiber self-lubricating material providing years of maintenance free operation.

WATER SEPARATOR AND AUTOMATIC OILER - Lubricates all air used for machine operation, does not lubricate air used for tire inflation, as do some competitive models.

HIGH TORQUE 1HP MOTOR - (air-electric models) Industrial strength high torque turntable drive motor eliminates tire remount stalling on low profile high performance tires (UL/CSA approved).

3-YEAR TRANSMISSION WARRANTY - Designed for extremely heavy use, the critical motor to turntable transmission linkage carries a full three (3) year replacement warranty.

PNEUMATIC BEAD ASSIST ARM

Up/Down Control Switch - Toggle switch allows single finger operation of all pneumatic PBA functions, with or without gloves.

Top Bead Roller - Provides easily controlled pneumatic power to drive upper beads down into the wheel drop center (while tire is turning) for easy lubrication prior to dismounting. Also provides pneumatic power assistance for safely remounting second bead on extremely low profile and Run Flat design tires.

Bead Depressor - Provides easily controlled pneumatic power to depress the tires sidewall during the remount cycle. This will prevent premature bead seating before the entire bead has been reinstalled on the wheel. Provides an added level of safety by keeping the technicians hands away from the bead area during this potential pinch point procedure. Additionally the Bead Depressor "follows" the tire around while turning to guarantee successful remount first time everytime.

Bottom Bead Roller - Provides easily controlled pneumatic power to unseat stubborn lower beads which may have accidentally reseated after the original bead breaking procedure. Also allows a technician to raise and hold wider tires up, to assist in safely and easily getting the second bead up onto the mount/demount head.

Wheel Centering Depressor - Provides downward pressure on a rim when working to clamp a low profile tire/rim combination. Will assist the technician in correctly seating the rim clamps between the tire and the rim when clamping from outside in where it is difficult to depress the tire sidewall enough to expose the rim edge.

SAFETY RESTRAINT ARM (OPTIONAL)

TIRE/RIM ASSEMBLY RESTRAINT - Safety Restraint Arm restrains tire and rim assembly to the tire machine during the inflation process reducing potential for injury caused by the unlikely event of catastrophic tire or rim failure.

SIMPLE SWING ARM DESIGN - SRA arm easily swings to the left when not in use allowing the technician to quickly and safely perform the inflation process without disrupting the tire changing procedure.

GRAVITY LOCK - SRA lock mechanism operates without any mechanical cam system eliminating the possibility of system deterioration or mis-adjustment from mechanical wear.

POSITIONING SAFETY INTERLOCK SWITCH - Integrated switch insures that SRA arm is centered on the tire/rim assembly before the inflation process can begin.

ANTI-ROTATION LOCK - Prevents SRA from rotating horizontally during inflation process.

1.3 MACHINE DIMENSIONS

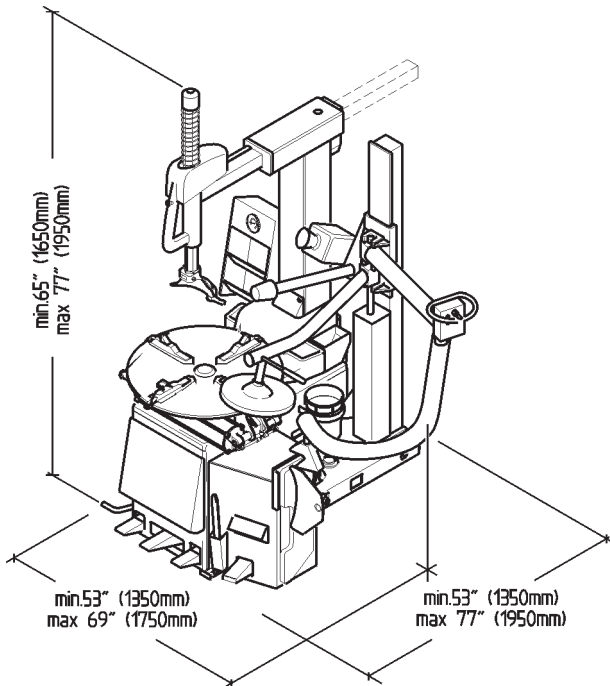

Figure 1.3-1

1104

1.4 STANDARD ACCESSORIES

#EAA0247G02A - Mount /Demount Tool (Fig. 1.4-1)



Figure 1.4-1

294

#EAA0247G05A - Assembly Bottle (Fig. 1.4-2)

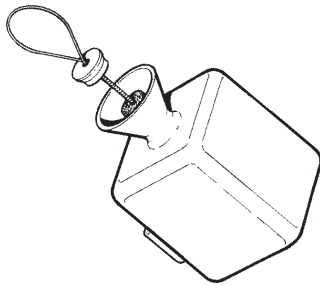

Figure 1.4-2

736a

#EAA0304G16A - Swab

(See Fig. 1.4-3 below)

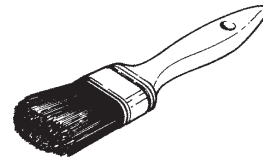

Figure 1.4-3

311

#EAA0247G06A - Insert for mounting head

(See Fig. 1.4-4 below)

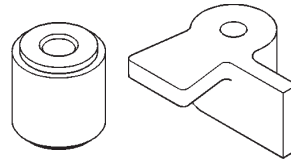

Figure 1.4-4

748 - 747

#EAA0304G34A - Special jaws 8" ATV/Motorcycles

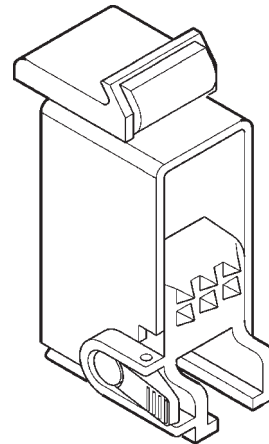

Figure 1.4-5

1049

1.5 OPTIONAL ACCESSORIES

#EAA0304G51A – Roller board (Fig. 1.5-1)

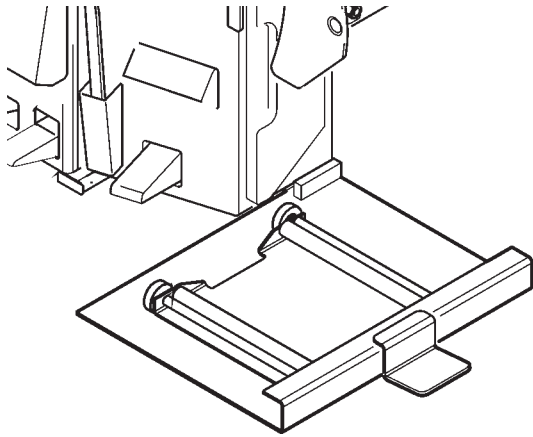

Figure 1.5-1

1100

#EAA0247G04A - M/D Tool Protection (Fig. 1.5-2)

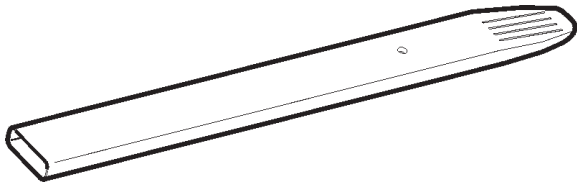

Figure 1.5-2

1078a

#EAA0304G15A – Bead Breaker Blade Protection (Fig. 1.5-3)

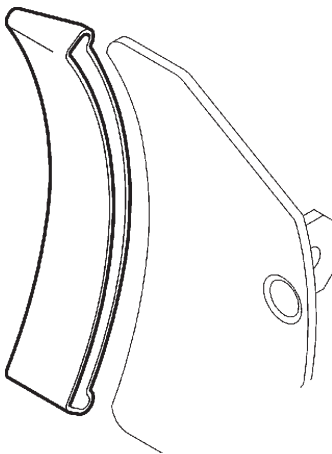

Figure 1.5-3

1101

1.6 GENERAL CAUTIONS

A. DURING THE USE AND MAINTENANCE OF THE MACHINE IT IS MANDATORY TO COMPLY WITH ALL LAWS AND REGULATIONS FOR ACCIDENT PREVENTION.

B. THE ELECTRICAL POWER SOURCE MUST HAVE A GROUND CABLE AND THE GROUND CABLE OF THE MACHINE MUST BE CONNECTED TO THE GROUND CABLE OF THE POWER SOURCE.

C. BEFORE ANY MAINTENANCE OR REPAIRS ARE ACCOMPLISHED THE MACHINE MUST BE DISCONNECTED FROM THE AIR AND ELECTRICAL SUPPLY.

D. NEVER WEAR TIES, CHAINS OR OTHER LOOSE ARTICLES WHEN USING, MAINTAINING OR REPAIRING THE MACHINE. LONG HAIR IS ALSO DANGEROUS AND SHOULD BE KEPT UNDER A HAT. THE USER MUST WEAR PROPER SAFETY ATTIRE - GLOVES, SAFETY SHOES AND GLASSES.

2.0 INSTALLATION

Your new Snap-on EEWH311A Tire Changer requires a simple installation procedure requiring only a few moments. Included in the literature packet with your machine is an instructional video. Section #2 of the video clearly details all installation procedures. Follow these instructions carefully to insure proper and safe operation.

The Tire Changer is delivered mounted to a wooden skid. Remove tire changer from its mounts carefully, taking care to avoid any back strain.

Place Changer where proper operation will be unobstructed to all sides. Install the machine in a covered and dry place.

Once placed in the desired location the tire changer must be bolted to the floor.

Secure the machine to the floor through the holes provided in the cabinet, using 3/8x2" anchor bolts (Recommended).

2.1 ELECTRICAL INSTALLATION



BUILDING ELECTRICAL INSTALLATION MUST BE MADE BY A LICENSED ELECTRICIAN.

Check that the electrical specifications of the power source are the same as the machine. The machine uses 110v, 60 hz, grounded single phase 20 amp source. Electric specifications are clearly marked on a label at the rear of the machine.



FAILURE TO PROVIDE PROPER ELECTRICAL SUPPLY AND GROUNDING WILL CREATE A SHOCK HAZARD TO THE OPERATOR.



2.2 AIR INSTALLATION



THE AIR INSTALLATION MUST BE MADE ONLY BY QUALIFIED PERSONNEL.



EXCESSIVE AIR PRESSURE CAN SERIOUSLY INJURE PERSONNEL AND DAMAGE THE MACHINE.

Ensure that the line pressure is within the limits required by the machine. If the pressure exceeds 170 psi (12 bar) it is mandatory to install a pressure regulator before the air inlet of the machine.

If the air pressure is lower than the minimum required of 110 psi (8 bar) the clamping power of the turntable and the bead breaker power may be insufficient for certain tires and substantially reduces tire changer performance.

It is suggested that the shop air supply be equipped with a water separator/dryer type modification for maximum performance.

After ensuring all the above proceed as follows:

A. Connect the machine to the air supply with a rubber hose (rated for the pressure) with an internal diameter of no less than 1/4" (6 mm).

- The air inlet fitting is provided with 1/4" NPT tapered pipe threads.

WARNING! BEFORE CONNECTING THE MACHINE TO THE AIR SUPPLY BE SURE ALL PERSONNEL ARE CLEAR OF THE MACHINE AND NO ITEMS ARE LEFT ON THE TURNTABLE.

B. It is strongly recommended that an air valve shut-off be installed between the shop air supply and the tire changer for routine maintenance and in case of an emergency.

C. Should you install any optional accessories, please refer to the relevant instructions.

D. Ensure the functional ability of the air lubricator by ensuring that the glass sight bowl is filled with air lubricant.

3.0 CONTROLS

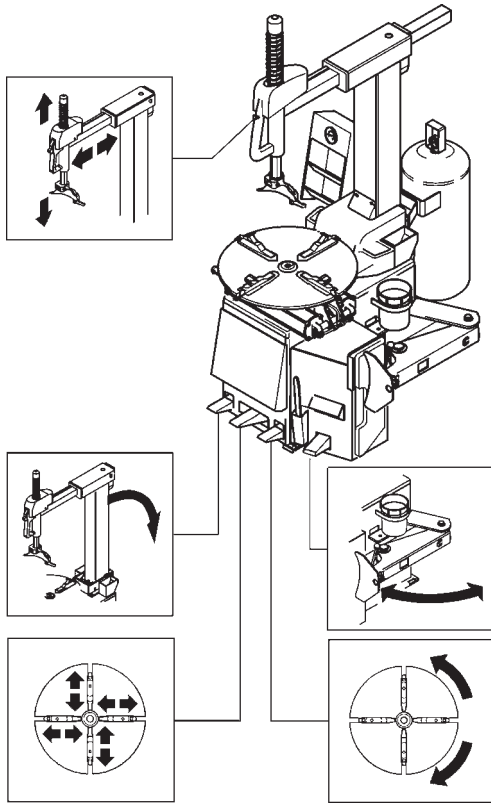

Figure 3.0-1

1033

Before operating the machine, take the time to familiarize yourself with the operation and function of all the controls (Figure 3.0-1).

- A** Press down and release, the first pedal from the left: the column tilts backwards. Do it again: the column tilts forward.
- B** Press down and release the second pedal from the left: the jaws of the turntable will retract. Do it again: the jaws will expand. If you press the pedal

prior to the end of the stroke and release, the jaws may be stopped in any position.

- C** Press down and hold, the second pedal from the right: the turntable turns clockwise.
 1. 3/4 down approximately, the turntable rotates at the minimum speed (8 rpm approx.). The torque is maximum in this condition.
 2. All the way down the turntable rotates at the maximum speed (14 rpm approx.).
 Lift the pedal and the turntable turns counter-clockwise.
- D** Open the bead breaker arm. Press down and hold, the first pedal from the right: by doing this you operate the bead breaker blade and the arm will move towards the machine. Release the pedal: the bead breaker blade will retract.

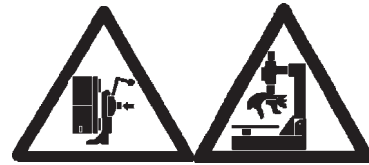

WARNING!
ALWAYS KEEP ARMS AND LEGS AWAY FROM THE BEAD BREAKER STROKE!!

E The push button on the handle allows to release the arms and position the mount/demount tool in the correct position.

1.
To unlock and let the slide with the tool go up: push the button firmly with the forefinger, in the direction of the arrow (Fig. 3.0-2).

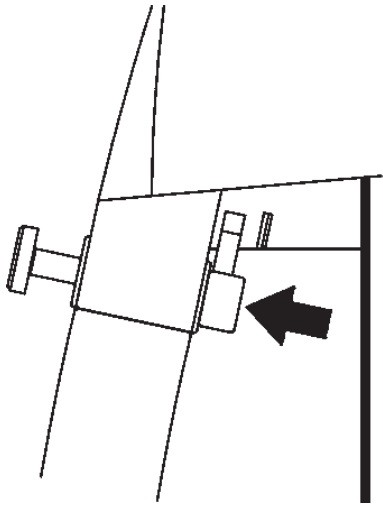

Figure 3.0-2

983a

2.
To unlock and let the slide with the tool go down: push the button with the thumb in the direction of the arrow, until the resistance increases (Fig. 3.0-3).

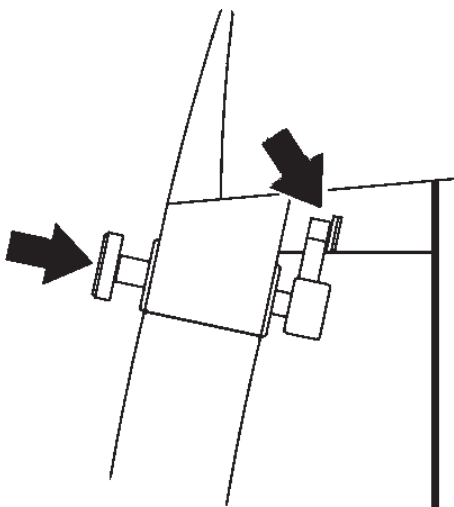

Figure 3.0-3

984a

3.
To lock: push the button firmly with the thumb (Fig. 3.0-4).

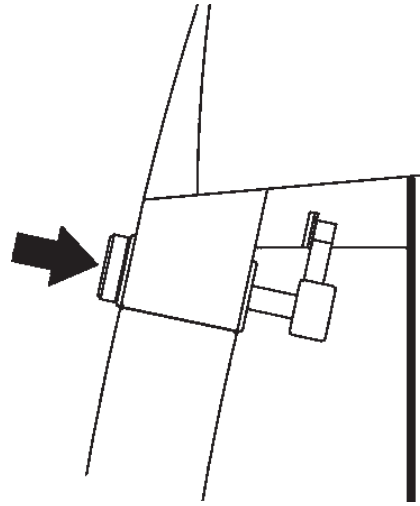

Figure 3.0-4

982a

F Press bead seater/inflator pedal on left side of the machine half way down (#1 Fig. 3.0-5): air will come from inflation hose end only.

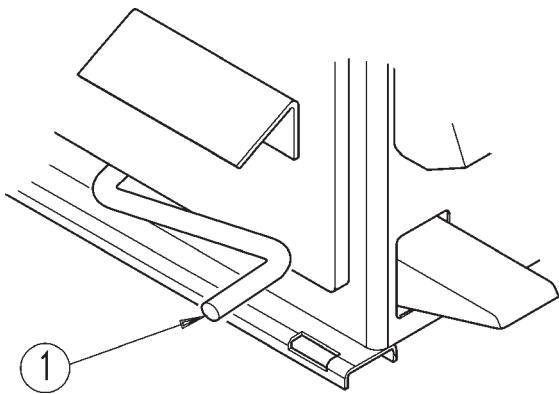

Figure 3.0-5

1005

- G** Press bead-seater pedal down swiftly to get air blast from the inflator jets. Air simultaneously comes out of inflator hose.



WARNING!!
WHEN OPERATING THE BEAD SEATER IT IS MANDATORY TO WEAR SAFETY GLASSES TO PROTECT EYES.

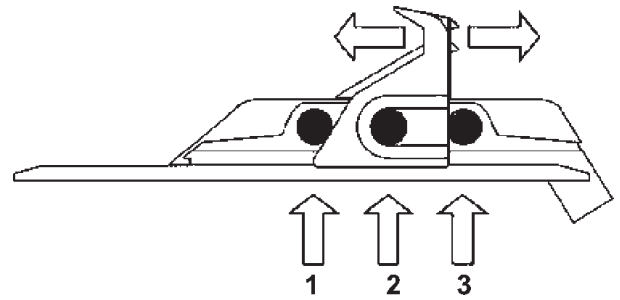

Figure 3.0-6

1052

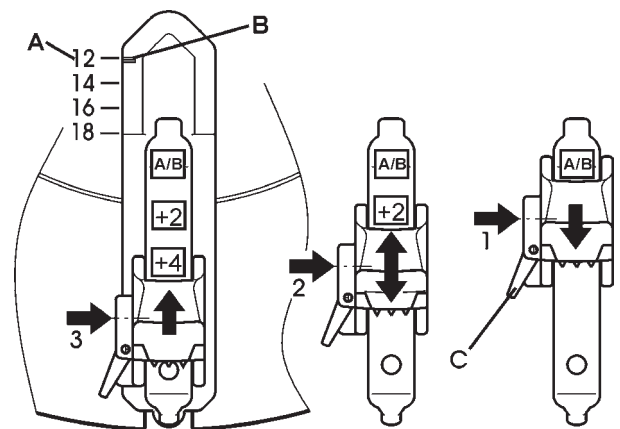

Figure 3.0-7

1053

- H.** The turntable jaws can be positioned in three different ways. Push the lever on the left side of each jaw and shift at the same each one (Fig. 3.0-6 / 3.0-7).

N.B.: Turntable capacity can be changed before pedal control.

WARNING!!
EACH JAW NEEDS TO BE SET AT THE SAME POSITION.

4.0 MOUNTING AND DEMOUNTING PRECAUTIONS

IMPORTANT!

BEFORE MOUNTING A TIRE ON A RIM, PAY ATTENTION TO THE FOLLOWING:

A. THE RIM MUST BE CLEAN AND IN GOOD CONDITION: IF NECESSARY CLEAN IT AFTER REMOVING ALL WHEEL-WEIGHTS INCLUDING 'TAPE WEIGHTS' INSIDE THE RIM.

B. THE TIRE MUST BE CLEAN AND DRY, WITHOUT ANY DAMAGE TO THE BEAD.

C. REPLACE THE RUBBER VALVE STEM WITH A NEW ONE OR REPLACE THE 'O' RING IF THE VALVE STEM IS MADE OF METAL.

D. IF THE TIRE REQUIRES A TUBE, MAKE SURE THE TUBE IS DRY AND IN GOOD CONDITION.

E. LUBRICATION IS NECESSARY TO MOUNT THE TIRE CORRECTLY AND GET A PROPER CENTERING. BE SURE YOU ARE USING APPROVED LUBRICANT ONLY.

F. MAKE SURE THE TIRE IS THE CORRECT SIZE FOR THE RIM.

4.1 DEMOUNTING TUBELESS TIRES

A. Remove all wheel-weights from the rim. Remove the valve stem or valve stem core and deflate the tire (Fig. 4.1-1).

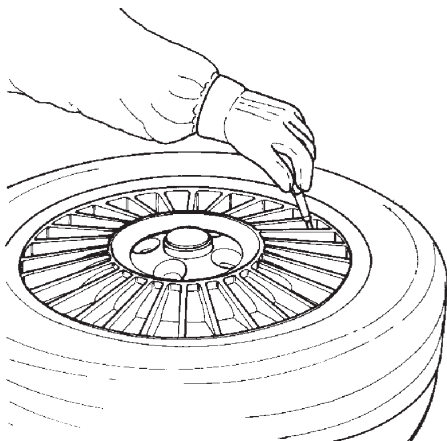

Fig. 4.1-1

B. Break both beads.

Hold open the Bead Breaker, roll the tire/rim into the Breaker area (Fig. 4.1-2). Ensure that the tire/rim assembly is flat against the rubber breaker pads on the side of the machine. Make certain that the bead breaker blade is not over the top of any portion of the rim. Now activate the bead breaker pedal. As soon as the bead dislodges from the rim, release the breaker foot pedal. It may be necessary to rotate the tire 90 degrees and repeat the above procedure to dislodge all beads.

Pay extra attention during this operation as it is easy to mistakenly keep your foot on the bead breaking pedal too long. This could potentially result in bead or rim damage (Fig. 4.1-2)

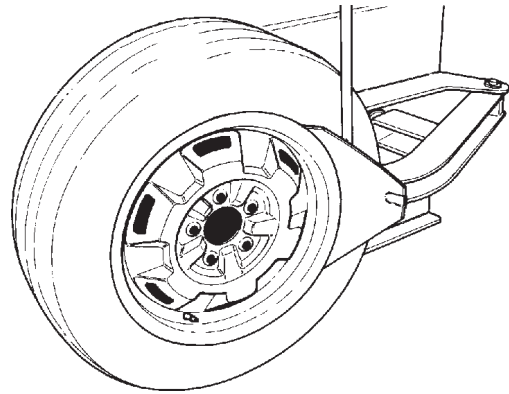

Fig. 4.1-2

536

NOTICE !

ON RUN FLAT TIRES WITH THE OPTIONAL LOW PRESSURE SENSOR INSTALLED, BREAK THE BEAD AT 90 DEGREES OFFSET FROM THE VALVE STEM. DAMAGE TO THE WHEEL AND/OR SENSOR MAY RESULT IF THE BEAD IS BROKEN AT ANY OTHER POINT ON THE RIM.

C. Set the rim clamps to the proper position: retract clamps to clamp the wheel from the outside.

When clamping small wheels (14" or smaller) from the outside, set the clamps at a diameter nearly equal to the rim diameter before placing the wheel on the clamps. This will help avoid the possibility of pinching the tire as the clamps retract.

NOTICE !

TO MINIMIZE THE RISK OF SCRATCHING ALLOY OR CLEAR COATED RIMS, THESE RIMS ARE CLAMPED FROM THE OUTSIDE.

D. Liberally lubricate both beads. Place the wheel **WITH DROP CENTER UP** (Fig. 4.1-3a) on the turntable, and clamp in position. It may be necessary to hold the tire and wheel down while clamping to insure contact between rim and clamp as shown in 4.1-3a.

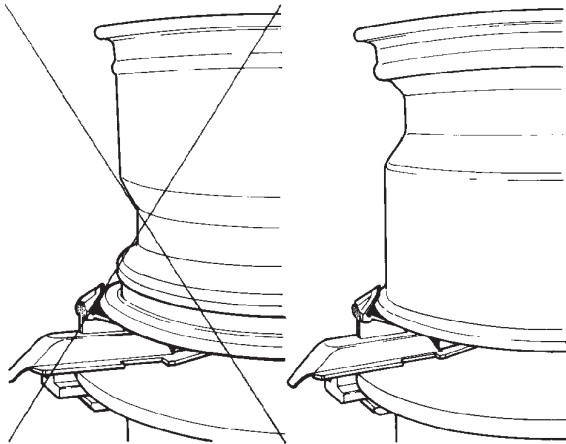

Fig. 4.1-3

Fig. 4.1-3a

331

E. Gently position the mount/demount head in contact with rim edge, now manually push the lock lever up and lock it into place. The mount/demount head automatically moves vertically up and away from the rim edge. Turn the swing arm adjustment knob clockwise until the mount/demount head moves horizontally away from the rim flange by approximately 1/16" (2mm); this is necessary to avoid any rim contact during the changing process. (Fig. 4.1-4).

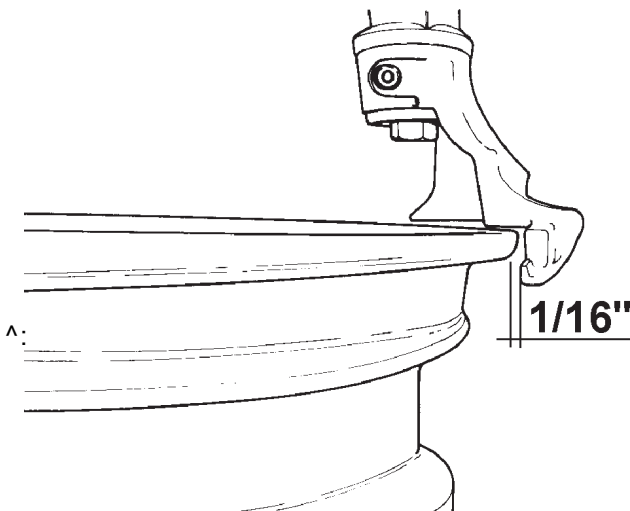
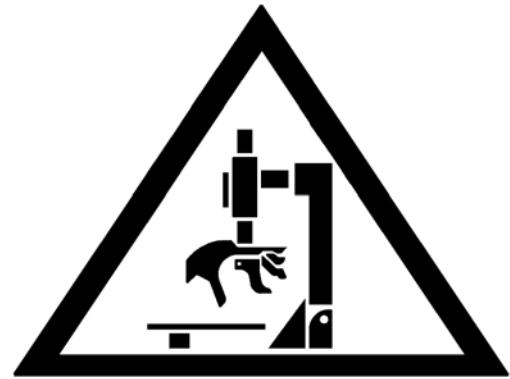

Fig. 4.1-4

332a



DANGER!!
Keep hands and fingers
clear of mount/demount
head during operation.

NOTE:

YOUR MACHINE IS SHIPPED WITH SEVERAL REPLACEMENT PLASTIC INSERTS (INSIDE STANDARD EQUIPMENT PACK). THE PLASTIC INSERTS WILL HELP AVOID DAMAGE FROM ACCIDENTAL CONTACT BETWEEN THE MOUNT/DEMOUNT HEAD AND THE RIM. THE PLASTIC INSERTS WILL NEED TO BE PERIODICALLY REPLACED.

MAINTENANCE NOTE:

IF THE MOUNT/DEMOUNT HEAD NYLON INSERTS ARE WEARING OUT PREMATURELY, THE CAUSE IS THE OPERATOR'S FAILURE TO CORRECTLY SET THE RIM DIAMETER ADJUSTMENT KNOB, CAUSING THE INSERT TO INCORRECTLY CONTACT THE RIM.

NOTE:

ONCE THE MOUNT/DEMOUNT HEAD IS POSITIONED PROPERLY, IDENTICAL WHEELS MAY BE CHANGED WITHOUT HAVING TO RESET THE HEAD.

F. Insert the mount/demount tool between the bead and the mount/demount head. Pry the bead onto the mount/demount head using the mount/demount head as the leverage point. To make this operation easier, insure that the bead of the tire, 180° across from the mount/demount head, is in the drop center of the wheel. Push the tire into the drop center with your hand or bead depressor tool if necessary.

It is suggested that the mount/demount tool be removed after lifting the bead onto the mount/demount head (Fig. 4.1-5), however, you may remove the tool after the bead has been removed.

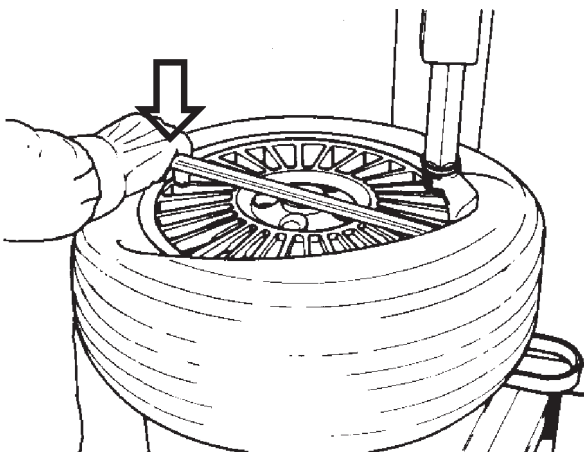

Fig. 4.1-5

333

G. Rotate the turntable clockwise (pedal down) and, at the same time, push down on the tire sidewall to move the bead into the drop center of the rim (Fig. 4.1-6).

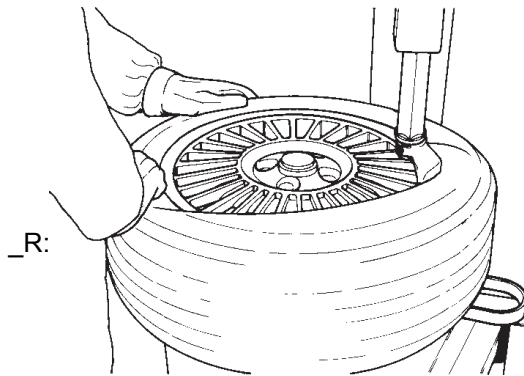

Fig. 4.1-6

334

H. Repeat the process for removing the lower bead. This time, lift the bead opposite to the mount/demount head to keep it in the drop center (Fig. 4.1-7).

If you meet difficulty during this operation, use the bead presser assist device PBA (see chapter 5.3).

Pivot the swing arm to the right and remove the tire.

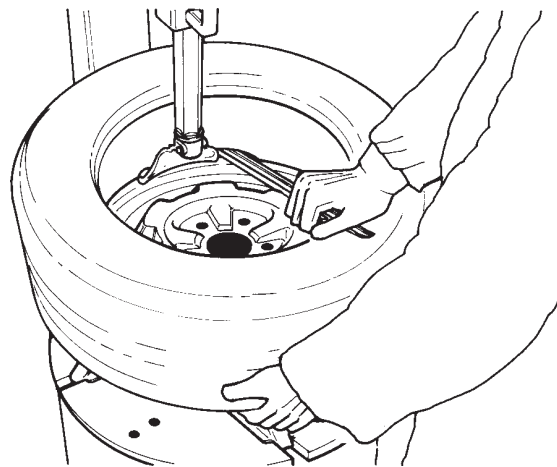

Fig. 4.1-7

335

4.2 MOUNTING TUBELESS TIRES

A. Clean entire rim surface (Fig. 4.2-1).

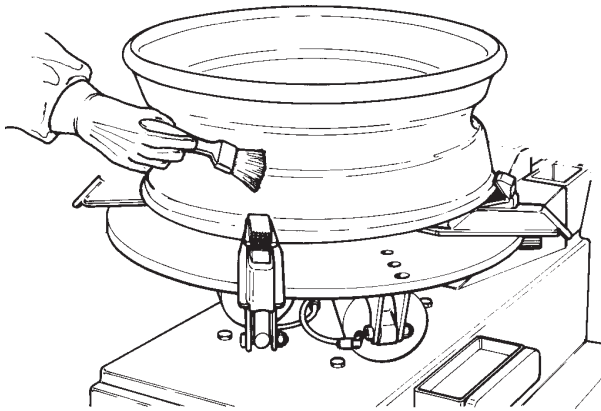

Fig. 4.2-1

336

Liberalily lubricate both beads of the tire with approved tire lubricant (Fig. 4.2-2).

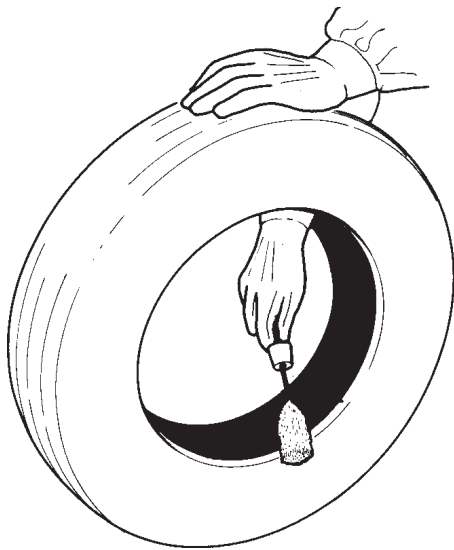

Fig. 4.2-2

337

NOTICE!
THESE LUBRICATION OPERATIONS ARE NECESSARY TO MOUNT THE TIRE CORRECTLY AND GET A PROPER CENTERING ON THE RIM. BE SURE YOU ARE USING APPROVED LUBRICANT ONLY.

NOTICE!
SOME TIRES HAVE A COLOR DOT THAT IS TO BE KEPT ON THE OUTSIDE OF THE WHEEL AND IS TO BE ALIGNED WITH THE VALVE STEM. IF THIS

IS THE CASE BE SURE TO ATTAIN PROPER ALIGNMENT PRIOR TO TIRE INFLATION.

B. Lock the rim to the turntable and rotate it so that the valve is at the 2 o'clock position. Place the tire to be mounted on the rim. Swing the mount/demount arm in so that the mount/demount head is in the working position. (Fig. 4.2-3) Position the lower bead on top of the mount/demount head and UNDER the mounting finger of the mount/demount head (Fig. 4.2-3). Turn the wheel clockwise (right pedal down) while simultaneously pushing the tire down into the drop center, opposite to the mount/demount head.

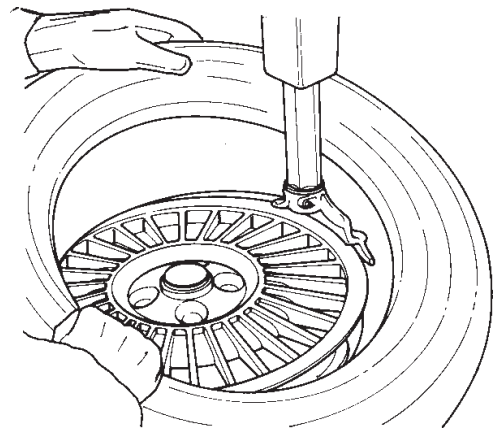

Fig. 4.2-3

338

C. Mount the upper bead following the same directions in section B. With low profile tires the Bead Holding Clamp (option EAA0247C70A Fig. 4.2-4) can help to prevent the top bead from prematurely seating during the mounting cycle. At the same you can use the PBA assist **NOTE:** Bead Holding Clamp must be removed prior to coming full circle and impacting the mount/demount head.

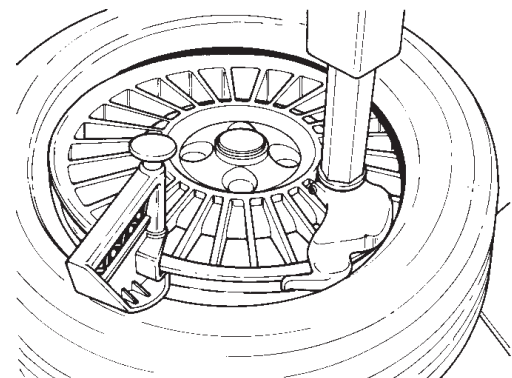

Fig. 4.2-4

339

4.3 IF THE TOP TIRE BEAD IS DIFFICULT TO MOUNT

Follow these instructions using the Bead Holding Clamp p/n EAA0247C70A (optional).

A. After installing, the bottom bead insert the tire tool to the left of the bead head as shown (Fig. 4.3-1a). To protect decorative rims use protective sleeve p/n EAA0247G04A (optional).

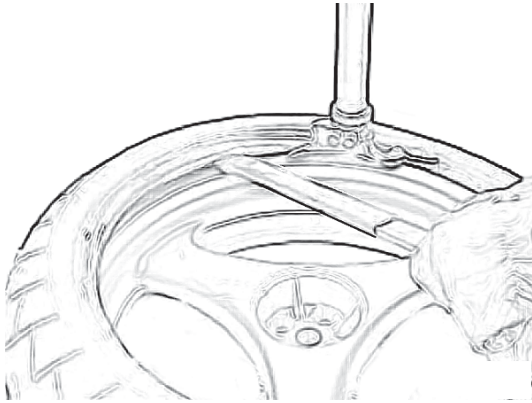

Fig. 4.3-1a

1077

- B.** Step on the foot pedal to rotate the turntable clockwise until the tire lever is tight against the bead head.
- C.** Using your right hand push and hold the tire bead opposite the bead head into the rim drop centre.
- D.** Position the bead clamp to hold the tire bead into the rim drop centre (Fig. 4.3-1).
- E.** As the turntable is turning use the tire tool in your left hand to raise and guide the tire bead onto the bead head (Fig. 4.3-1b).

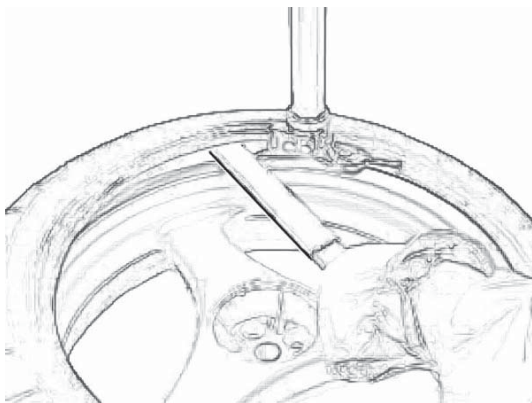

Fig. 4.3-1b

1076

F. Continue to rotate the turntable until the top bead is mounted. Do not remove the tire tool or bead clamp until the foot pedal is released.

4.4 INFLATION OF TUBELESS TIRES.

Make sure that both beads are properly lubricated.



BEAD SEATING IS THE MOST DANGEROUS PART OF MOUNTING A TIRE.

IT IS POSSIBLE TO INCORRECTLY MOUNT TIRES THAT ARE 1/2" SMALLER IN DIAMETER THAN THE RIM THAT THEY ARE MOUNTED ON. WHILE THESE BEADS WILL SEAL, IT IS IMPOSSIBLE TO GET THEM TO SEAT IN THEIR PROPER POSITION. EXPLOSION OF A TIRE MAY CAUSE SEVERE INJURY OR DEATH.

SAFETY RESTRAINT ARM MUST BE IN PLACE PRIOR TO ATTEMPTING BEAD SEATING OR INFLATION.

NEVER EXCEED THE MAXIMUM PRESSURE ALLOWED BY THE TIRE MANUFACTURER.

IF YOU CLAMPED THE RIM FROM THE OUTSIDE IT MUST BE UNCLAMPED WHEN INFLATING BUT ONLY AFTER THE SRA IS IN PLACE.

THE OPERATOR MUST STAND CLEAR FROM THE WHEEL WHEN INFLATING, AND PRESSURE MUST BE MONITORED FREQUENTLY TO AVOID OVER INFLATION.

BEFORE INFLATING A TIRE, CHECK THE CONDITION OF THE TIRE AND THE RIM.

Inflate tire according to manufacturer's recommendations.

Due to unusual configurations or the stacking of tires the inflation process may be difficult. To assist with this problem the Snap-on Tire Changers are equipped with bead seater jets integrated into the tabletop.

To utilize the bead seater proceed as follows:

A. Position the safety restraint arm over center of wheel assembly. The safety arm is lifted upward by grasping the safety restraint position knob and lifting upward while simultaneously depressing the anti-rotation lock arm. Swing SRA arm assembly so the rubber retainer is centered over the rim. Note that air pressure to the inflation hose will not flow until the arm is centered over the rim.

B. Connect the inflation hose to the valve stem.

C. Lift the tire with both hands so that the upper bead is sealed to the rim edge (Fig. 4.4-1).



Fig. 4.4-1

⚠ DANGER

NEVER STAND OVER TIRE WHEN ATTEMPTING TO SEAT BEADS OR DURING INFLATION.

D. Press the inflation pedal down swiftly to the end of its travel to activate the bead seater jets. (Page 10 Fig. 1.2-1 item 8)
The top bead is already sealed by the lifting motion. Therefore, the air from the bead seater jets will enter the tire impacting on the top sidewall and rebound into the bottom sidewall driving it into place and seating the bead, creating an air seal.

WHEN OPERATING THE BEAD SEATER, ALWAYS WEAR SAFETY GLASSES TO AVOID INJURY TO EYES.

E. Install valve core, if removed. Complete inflation to manufacturer's suggested pressure. Never exceed pressure listed on tire sidewall.

5.0 DEMOUNTING TUBE-TYPE TIRES

A. For breaking the bead operate as described for the tubeless tires in section 4.1. point A to F.

In this case the valve is part of the tube.

NOTICE!

BE CAREFUL NOT TO DAMAGE THE TUBE DURING THE BEAD-BREAKING OPERATION. THE VALVE SHOULD BE OPPOSITE TO THE BLADE OF THE BEAD BREAKER.

B. To demount the first bead, place the valve at 2 o'clock position.

NOTICE!

BE CAREFUL NOT TO CATCH THE TUBE WITH THE MOUNT/DEMOUNT TOOL, WHEN LIFTING THE BEAD ON THE MOUNTING FINGER.

After demounting the first bead carefully, remove the tube before demounting the second bead, as described in section 4.1.

5.1 MOUNTING TUBE-TYPE TIRES

A. Perform steps described in section 4.2.A. **DO NOT** lubricates the tube. Talc can be used to assist with tire positioning if necessary.

B. Confirm that the tube is the correct size for the tire to be mounted. (Fig. 5.1-1).

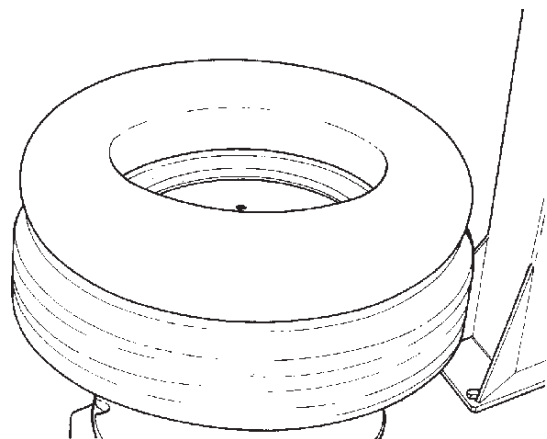

Fig. 5.1-1

C. Inflate the tube slightly: if held with the index finger it should bend a little (Fig. 5.1-2).

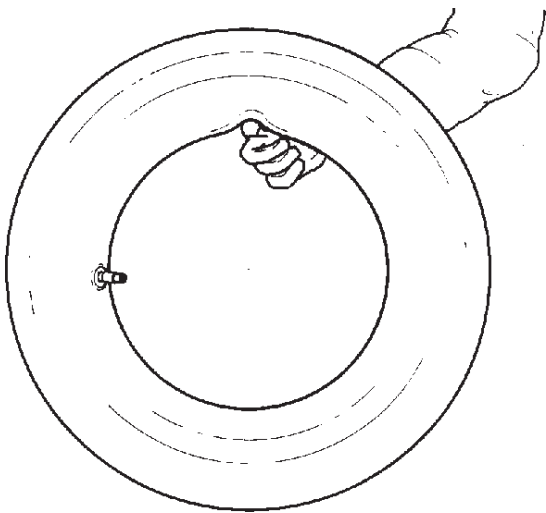

Fig. 5.1-2

342

D. Mount the first bead as described in section 4.2.B. Put the tube inside the tire and connect the inflation air line to the tube valve to hold the tube in place. (Fig. 5.1-3). Mount the top bead following the directions above.

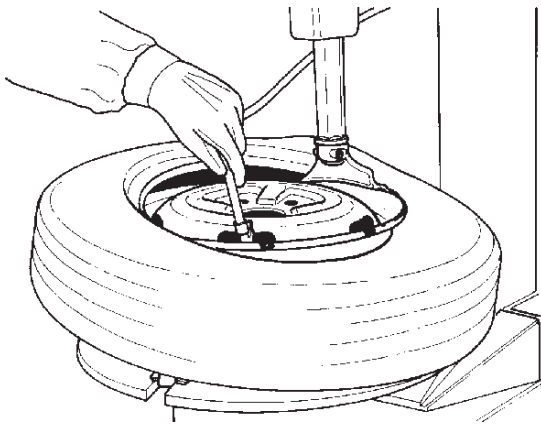

Fig. 5.1-3

343

5.2 INFLATING TUBE-TYPE TIRES.

Make sure that both beads are properly lubricated.

⚠ DANGER

BEAD SEATING IS THE MOST DANGEROUS PART OF MOUNTING A TIRE.

NEVER STAND OVER TIRE WHEN ATTEMPTING TO SEAT BEADS OR DURING INFLATION. IT IS POSSIBLE TO MOUNT TIRES THAT ARE 1/2" SMALLER IN DIAMETER THAN THE RIM THAT THEY ARE MOUNTED ON. WHILE THESE BEADS WILL SEAL, IT IS IMPOSSIBLE TO GET THEM TO SEAT IN THEIR PROPER POSITION. EXPLOSION OF A TIRE MAY CAUSE SEVERE INJURY OR DEATH.

⚠ DANGER

NEVER EXCEED THE MAXIMUM PRESSURE ALLOWED BY THE TIRE MANUFACTURER.

THE RIM MUST BE UNCLAMPED WHEN INFLATING BUT ONLY AFTER THE BEADS HAVE BEEN SEATED.

THE OPERATOR MUST STAND CLEAR FROM THE WHEEL WHEN INFLATING, AND PRESSURE MUST BE MONITORED FREQUENTLY TO AVOID OVER INFLATION.

BEFORE INFLATING A TIRE, CHECK THE CONDITION OF THE TIRE AND THE RIM.

To inflate the tire unlock the rim and start inflating while pressing the valve towards the inside (this is necessary to avoid air pockets forming between tube and the tire) (Fig. 5.2-1).

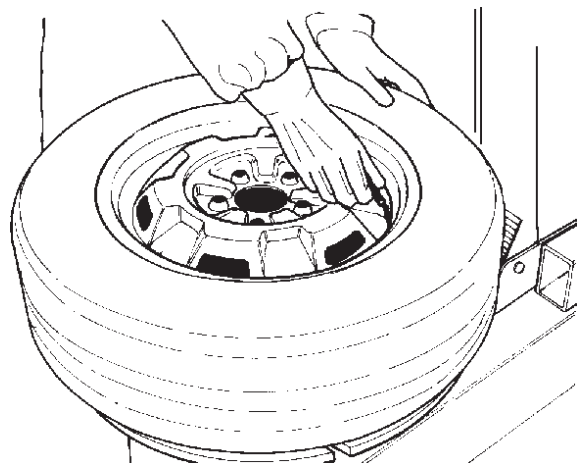

Fig. 5.2-1

537

Ensure that the tire is correctly centered on the rim and complete inflation.

5.3 OPERATING THE PNEUMATIC BEAD ASSIST

All Snap-on model EEWH311A High Performance Model come equipped with a specially designed "Pneumatic Bead Assist Device" (referred to as the PBA). The PBA offers the combined benefits of both reducing the amount of physical exertion required by the tire technician as well as providing an added level of safety by allowing the machine to do the work rather than the technician. Simply put the PBA allows the technician to apply pneumatic power when most needed in the tire changing process.

The PBA consists of three separate devices which are attached to a powerful pneumatic cylinder which raises and lowers the devices as needed.

First is the Upper Bead Roller. The Bead Roller can be used to drive stiff upper beads down into the drop center of the rim. This function will be useful both when lubricating a tire prior to being removed from the rim as well as when remounting the second bead of a High Performance or Runflat design tire (Fig. 5.3-1).

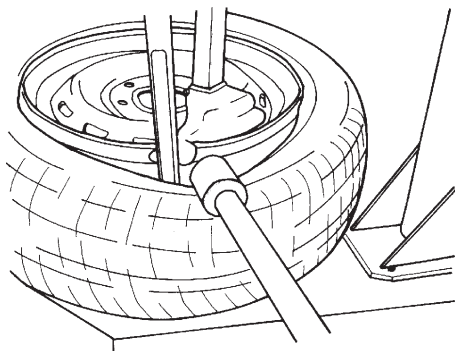

Fig. 5.3-1

901

Move the bead roller into position overtop of the tires sidewall. While the turntable is turning lower the roller down into contact with the sidewall. Depress the bead down 1-2" now you may insert the lubrication swab to safely lubricate the upper bead.

Second is the Bead Depressor. The Bead Depressor consists of a formed rubber head mounted on a movable arm designed to comfortably depress the tires sidewall. The size and mobility of the arm will allow the formed head to depress the tire at any position around the 360 degrees of rotation. The Bead Depressor will be useful numerous times throughout the remount cycle. When remounting a tire the bead depressor will ensure that the bead stays down in the drop center of the rim until the entire bead has been remounted onto the rim.

Once the first bead has been remounted move the bead depressor into position just behind the mount/demount head. Now depress the second bead down 1-3". Activate the turntable, as the second bead moves across the mount/demount head the bead depressor will follow the tire around and ensure that the bead does not prematurely seat causing the mount/demount head to jam (Fig. 5.3-2).

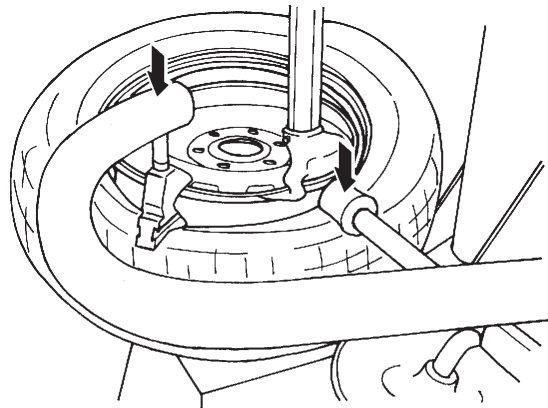

Fig. 5.3-2

905

The third tool integrated into the PBA is the Bottom Bead Roller. This device will be useful at several times during the demount cycle. First the bottom roller can be used to unseat a stubborn lower bead which may have resealed after the bead breaking process and before tire removal. Secondly the lower roller can be used to hold a wide tire up after the first bead has been removed. This will assist in getting the second bead up onto the mount/demount head (Fig. 5.3-3).

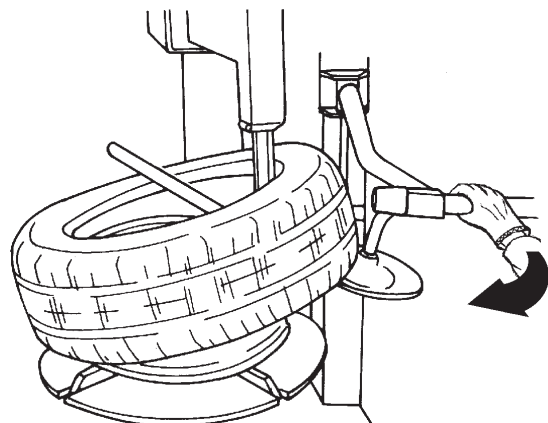

Fig. 5.3-3

903

When working to loosen a stubborn lower bead simply swing the bottom bead roller under the lower sidewall and apply slow upward pressure. Be careful not to mistakenly swing far enough in to contact the rim.

When working to safely secure the second bead for removal, insert the tire tool all the way past first and second bead. Now swing the bottom bead roller into position under the lower sidewall and lift. As the sidewall comes up, so will the tire bar easily flipping onto the mount/demount head.H:

5.4 MOUNTING AND DEMOUNTING MOTORCYCLE TIRES

To mount and demount motorcycle/ ATV or motor-scooter wheels it is necessary to utilize the 8" motorcycle jaws (part number EAA0304G34A).

The bead-breaking, mounting and demounting technique is the same as per the car, tubeless or tube-type tires.

NOTICE!
MOTORCYCLE RIMS MUST ALWAYS BE CLAMPED FROM THE OUTSIDE. AIR PRESSURE MUST NOT EXCEED 110 PSI (8 BAR) WHEN CLAMPING MOTORCYCLE RIMS.

6.0 MAINTENANCE

⚠ WARNING

BEFORE STARTING ANY MAINTENANCE OPERATION ENSURE THAT THE MACHINE IS DISCONNECTED FROM THE AIR AND ELECTRIC SUPPLY.

A. Periodically clean the vertical hexagonal rod with liquid detergent. After this immediately lubricate with a light lubricating oil (Fig. 6.0-1).

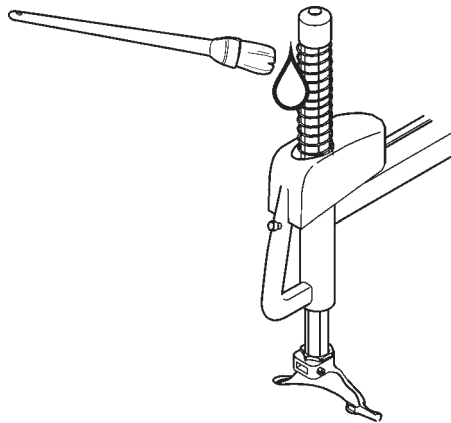

Fig. 6.0-1

1106

B. Periodically clean all moving metal parts and lubricate with oil.

C. Weekly clean the teeth of the jaws (1 Fig. 6.0-2) with a wire brush, check the nylon clamping jaw insert (2) and replace if worn. Clean the lock / un-lock mechanism of the clamping jaw (3) and slightly lubricate it.

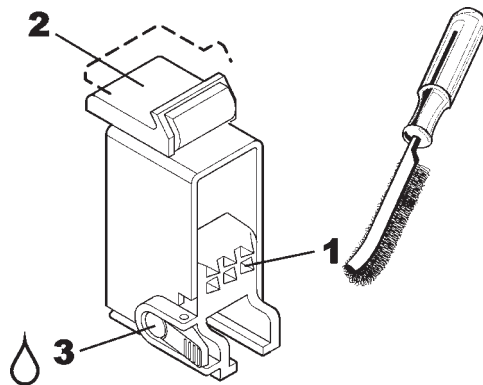

Fig. 6.0-2

1105

D. Inspect and replace as necessary the plastic mount/demount head insert. The insert is held in place by a small roll pin. Drive the pin out with a punch, replace after new insert is installed.

E. Lubricate piston rods of turntable air cylinders with oil as needed.

F. Periodically wash all plastic parts with cold water and soap or window cleaner.

G. Check the bead breaker pads. Replace if worn.

H. Discharge water from air filter every day!! Do this by turning the knob "B" clockwise and push upward. Water will automatically be discharged. (see 'B' at Fig. 6.0-3).

I. Check the automatic air lubricator oil level weekly. When adding oil to the lubricator, disconnect the air supply first, remove the fill screw 'A', and add oil as needed. Make sure seals are in place when replacing the cap.

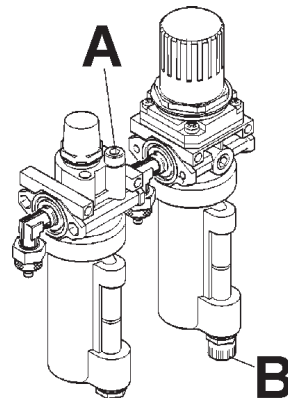

Fig. 6.0-3

553

NOTICE!
USE ONLY OILS FOR AIR DEVICES, DO NOT USE BRAKE FLUID OR OTHER NON-SUGGESTED LUBRICANTS.

Suggested oils for the filter/lubricator unit:

10W Non detergent / Air Tool Oil

e.g.	
TAMOIL:	WHITE MINERAL OIL 15
SHELL:	ONDINA OIL 15
BP:	ENERGOL WT 3
TOTAL:	LOBELIA SB 15
ESSO:	MARCOL 82



Snap-on Incorporated
2801 80th Street
Kenosha, WI 53141 - 1410

For Service Call:
1-800-225-5786

Notice: The information contained in this document is subject to change without notice. Snap-on Incorporated makes no warranty with regard to this material. Snap-on Incorporated shall not be liable for errors contained herein or for incidental consequential damages in connection with furnishings, performance, or use of this material.

This document contains proprietary information which is protected by copyright and patents. All rights are reserved. No part of this document may be photocopied, reproduced, or translated without prior written consent of Snap-on Incorporated.

Snap-on® is a registered trademark of Snap-on Incorporated