

**BLACKHAWK®**



***Power-Pro® XXL***



# BLACKHAWK®



## Power-Pro® XXL Frame Straightening Rack

In today's collision repair market, capital equipment needs to provide for a productive workspace that reduces cycle times while providing the technician with an ergonomic, multi-purpose workstation with greater access to the vehicle with controlled power; to get the job done. The *Power-Pro XXL* delivers on those features and much more.

The *Power-Pro XXL* delivers with numerous working heights up to 55" with the strength to lift up to 9,900 lbs.



- 10 Tons of pulling force delivers 360° without any loss in pulling height

- The Shark® 3 makes for the perfect combination with the *Power-Pro XXL* for quick and easy installation.
- Drive-on bench and removable access ramps.

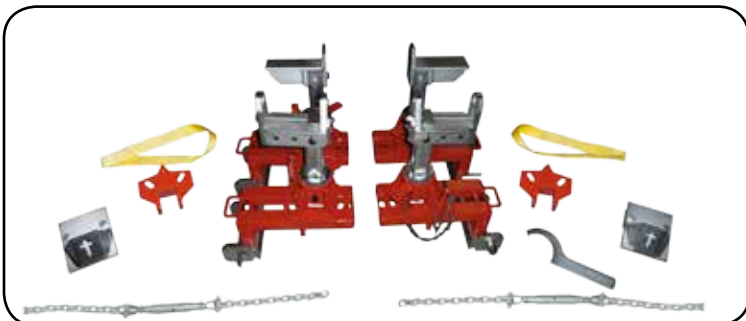

Optional Anchoring System for Chassis Type Vehicle and Four Wheel Drive (BHPLT19US)



Optional Vector Pulling Arm with Accessories (BHPLT4001US)

# Standard Power-Pro® XXL Accessories

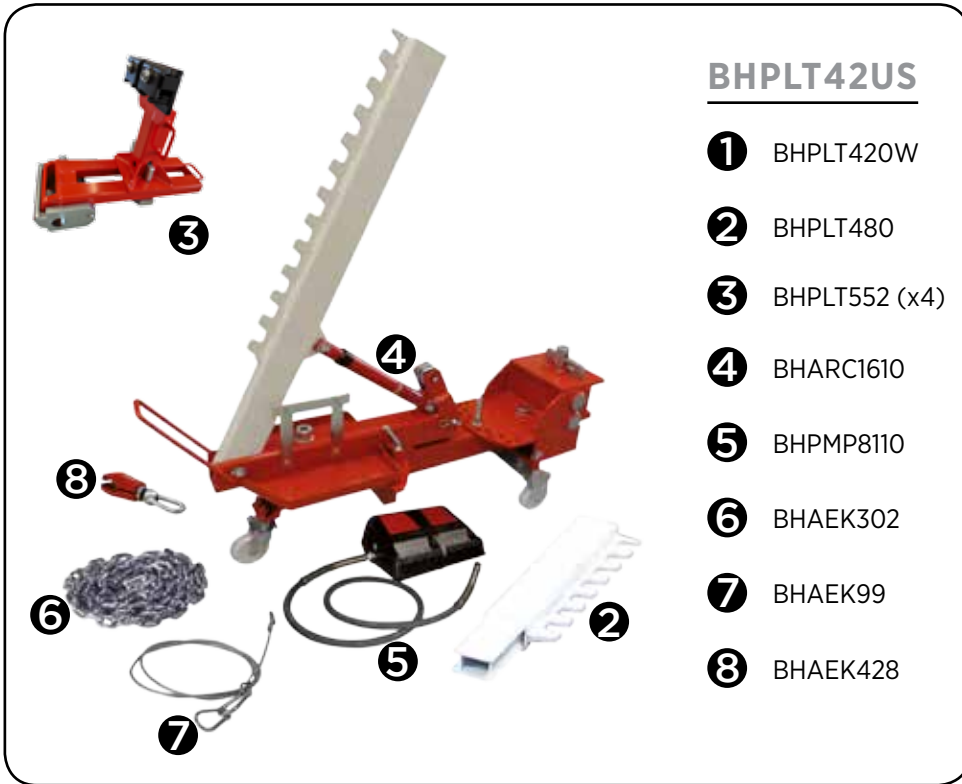

**BHPLT42US**

- ① BHPLT420W
- ② BHPLT480
- ③ BHPLT552 (x4)
- ④ BHARC1610
- ⑤ BHPMP8110
- ⑥ BHAEK302
- ⑦ BHAEK99
- ⑧ BHAEK428



**BHPLT560US**

Hydroelectric Pump



**BHPLT553US**

4 x Wheel Stands



**Dozer**

Double articulating dozer; creates no dead zones for pulling

## **BHPLT55US**

<b>A</b>	<b>BHPLT5500US</b>	Frame + Lift	1
<b>B</b>	<b>BHPLT555US</b>	Set of two standard ramps	7
<b>C</b>	<b>BHPLT556US</b>	Set of two ramps with stop	1
<b>D</b>	<b>BHPLT557US</b>	Set of two access ramps	1
<b>E</b>	<b>BHPLT558US</b>	Set of two access ramps	1

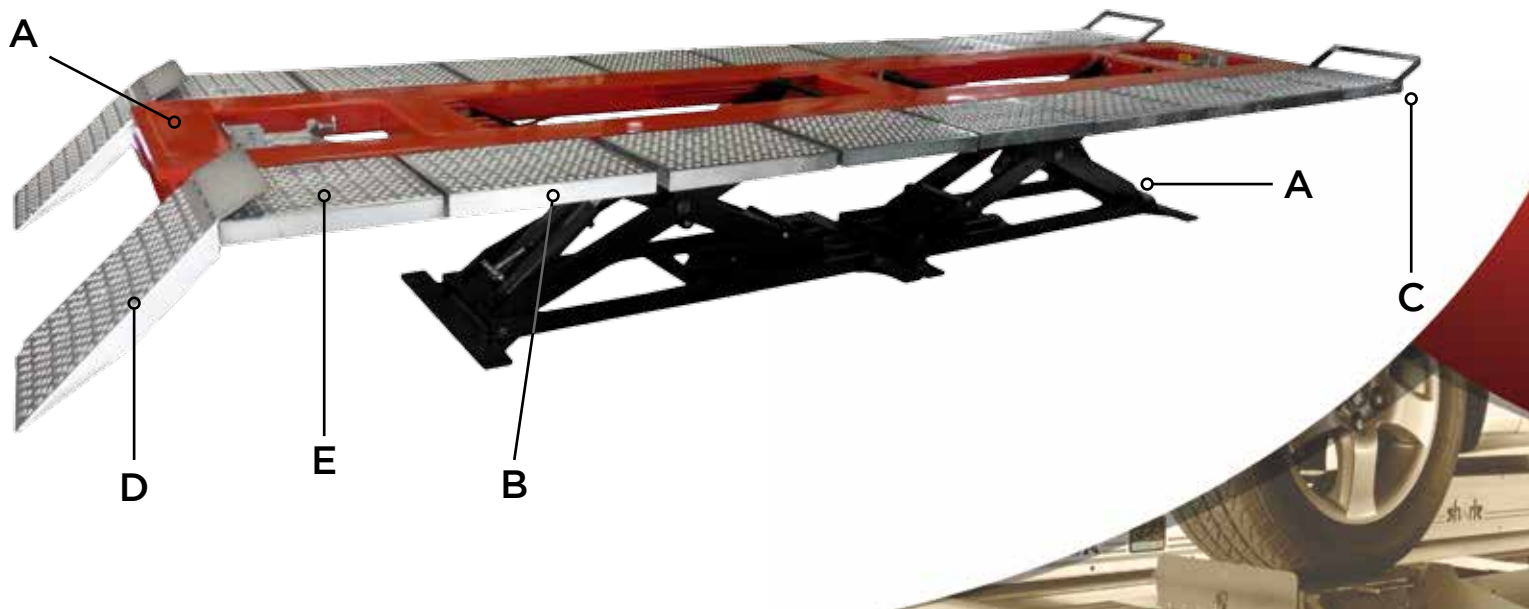

## Power-Pro® XXL Technical Specifications

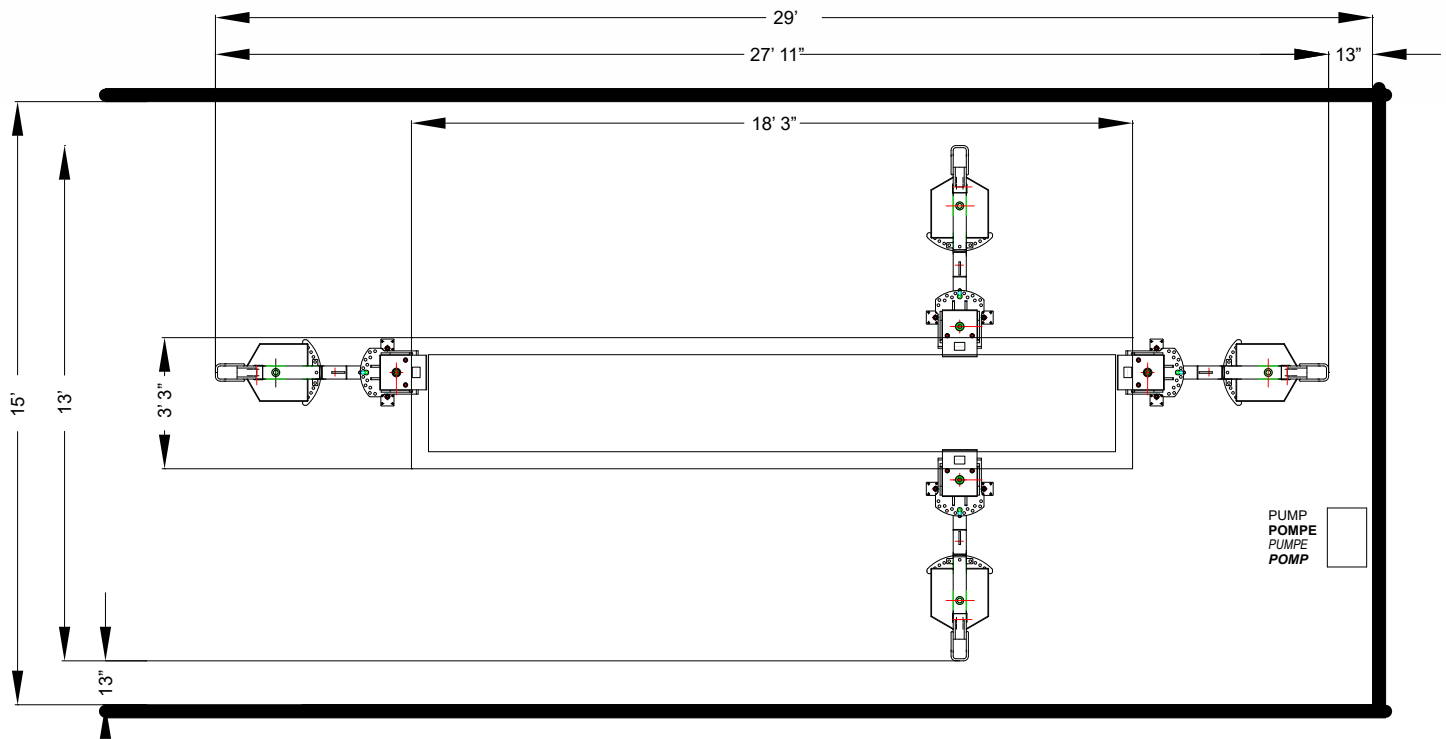

### TECHNICAL SPECIFICATIONS

- Part Number: BHPLT55US
- Frame Length: 216.5" (5,500 mm)
- Frame Width: 39" (1,000 mm)
- Minimum Lifting Height: 5" (130 mm)
- Maximum Lifting Height: 55" (1,400 mm)
- Lifting Capacity: 9,921 lbs (4,500 kg)
- Total Weight: 3,968 lbs (1,800 kg)
- Total Length with Ramps: 236" (6,000 mm)
- Pulling Capacity Dozer Type: 10 T with 360° Pulling
- Space Approximation: 23' x 29.5' (7 x 9 m)
- Electro Hydraulic Pump: 220V 1Ph 60Hz

### KEY FEATURES

- For lifting, anchoring and straightening of damaged cars
- For light to heavy duty damage
- Compatible with electronic or mechanical measuring systems
- Superb access to vehicle underside with the greatest amount work separation
- Infinitely adjustable working height
- Removable ramps

Snap-on Equipment • Blackhawk / 309 Exchange Avenue / Conway, Arkansas 72032 U.S.A.  
Fax: 501-450-2085 / Toll Free: 1-877-482-4866 / [www.blackhawkcr.com](http://www.blackhawkcr.com)