



# Scissor

Alignment Lift Equipment



4810605AFX



***Starts Lower - Lifts Higher - Uses Less Space!***



## Get The Most Effective Use Out Of Your Service Bay Space

### Five Scissor Lifts in the Same Space as Four 4-Post Lifts

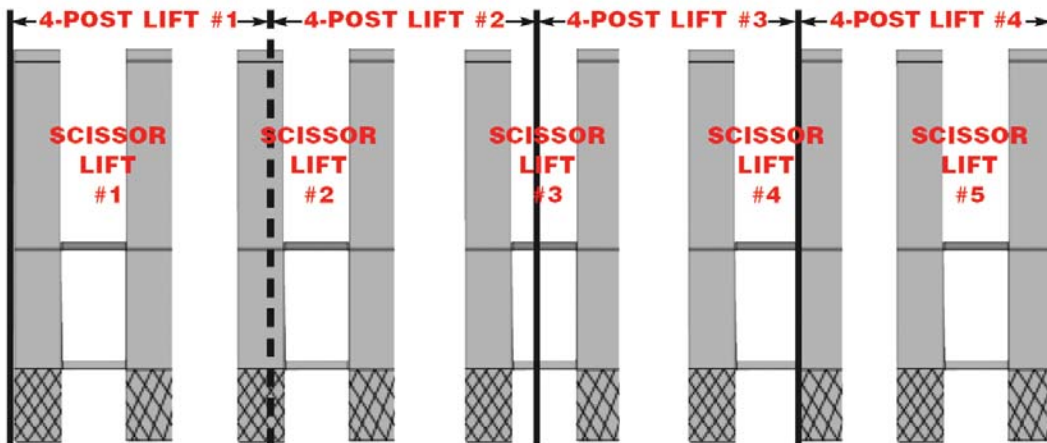

Get maximum productivity out of your available bay space with the use of John Bean's Scissor lifts. Scissor lifts also lift straight up & down for better front to rear space utilization as well.

### Flush Mount (Model No. 4810605AFM)



Optional Premium Turnplates



Flush Mount 72" Rear Slip Plates

### FULLY ALIGNMENT EQUIPPED

- Durable 72 inch "right side up" flush mount maintenance free slip plates. Oversize roller balls rotate on the under side of each slip plate and not on the deck surface. Strategically positioned openings in the deck under each slip plate quickly disperse water and dirt for maintenance free reliable performance.
- Optional kits are available for use with CCD & V3D Aligners, Roll Back, Roll Forward and Back. Discuss with your local Equipment Sales Specialist.

# Scissor Alignment Lifts

## The Right Lifts For The Right Jobs

### Features

- Totally open access between the runways front to rear.
- 10,000 lb. lifting capability
- "Proportionally Controlled – Hydraulic Synchronized" lifting systems with 2 powerful heavy duty lifting cylinders to maintain level from floor to **73" of lifting height**.
- Contained top and bottom UHMW slide blocks for smooth and uniform lifting.
- Large twin interlocking serri-form mechanical safety racks with 18 level and locked positions.
- Durable 72", "**Right Side Up**" flush mount, maintenance free slip plates. Oversize roller balls rotate on the underside of each slip plate and not on the runway surface. Strategically positioned openings in the runway under each slip plate quickly disperse water and dirt for maintenance free reliable performance.
- Reinforced 26" wide "**Coach**" style runways, alignment accuracy for cars and dual wheel trucks.
- 2 work steps, 8 positions on each runway, easy access to under hood for steering adjustments.
- Triple safety system, air actuated mechanical locks, pressure sensing flow control valves and velocity fuses.
- Low profile stance of 9" allows gentle drive on approach for low profile vehicles.
- Compact, enclosed control console protects core components from the shop environment.
- Full length base frame accommodates fast installation and adds to rugged durability.
- Standard, In-rack air kit for rolling jacks and air tools.

### Optional Accessories

- Air/Hydraulic Rolling jacks for wheel free lifting
- Stainless Steel Front Radius Turn Plates slide on a UHMW layer preventing deck scratching
- Drive-thru Kit



**Surface Mount (Model No. 4810605AFX)**

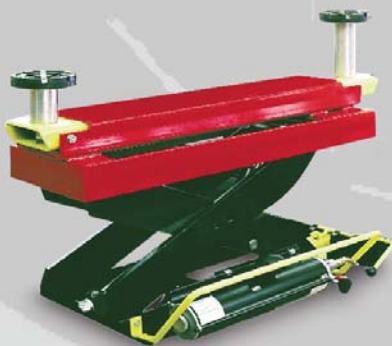

### JOHN BEAN ROLLER JACKS

JBC's complete line of air/hydraulic roller jacks are versatile, durable and optimize the profitability of any lift. A low profile design eliminates the need to swing away when lift is lowered. A high lifting height enables more access for under-car repairs. Interchangeable adapters make lifting fast for brake work and tire service on passenger cars, light trucks and vans. Easy to maintain and built to last.

Model	Capacity	Lift Pad Height	Raised Height	Lowered Height	Shipping Weight
JBC215	5,000 lbs.	3" & 6" stacks	13"	Less than 1" above runway	320 lbs.



## SPECIFICATIONS

Model	Full Open Center	4 Wheel Alignment Wheel Base (min / max)	2 Wheel Alignment Wheel Base	General Service Max. Wheel Base	Deck Surface Length	Lifting Capacity	Overall Width	Runway Width	Overall Length	Maximum Raised Height	Shipping Weight
4810605AF	Y	84.5" / 155"	165"	179"	195 1/2"	10,000 lbs.	92 3/4"	26"	254 5/8"	73 1/2"	4,430 lbs.
4810605AFX	Y	84.5" / 155"	175"	189"	205 1/2"	10,000 lbs.	92 3/4"	26"	264 5/8"	73 1/2"	4,630 lbs.
4810605AFM*	Y	84.5" / 155"	165"	179"	195 1/2"	10,000 lbs.	92 3/4"	26"	218 5/8"	73 1/2"	4,280 lbs.
4810605AFMX*	Y	84.5" / 155"	175"	189"	205 1/2"	10,000 lbs.	92 3/4"	26"	228 5/8"	73 1/2"	4,480 lbs.

Lift time on all units approximately 80 seconds, lowering time on all units approximately 60 seconds. Minimum lowered height on all units approximately 9"  
 All units come standard with 230V / 1Ph / 60 Hz power requirements. (Other power requirements are available as an option.)  
 \*Flush Mount Models

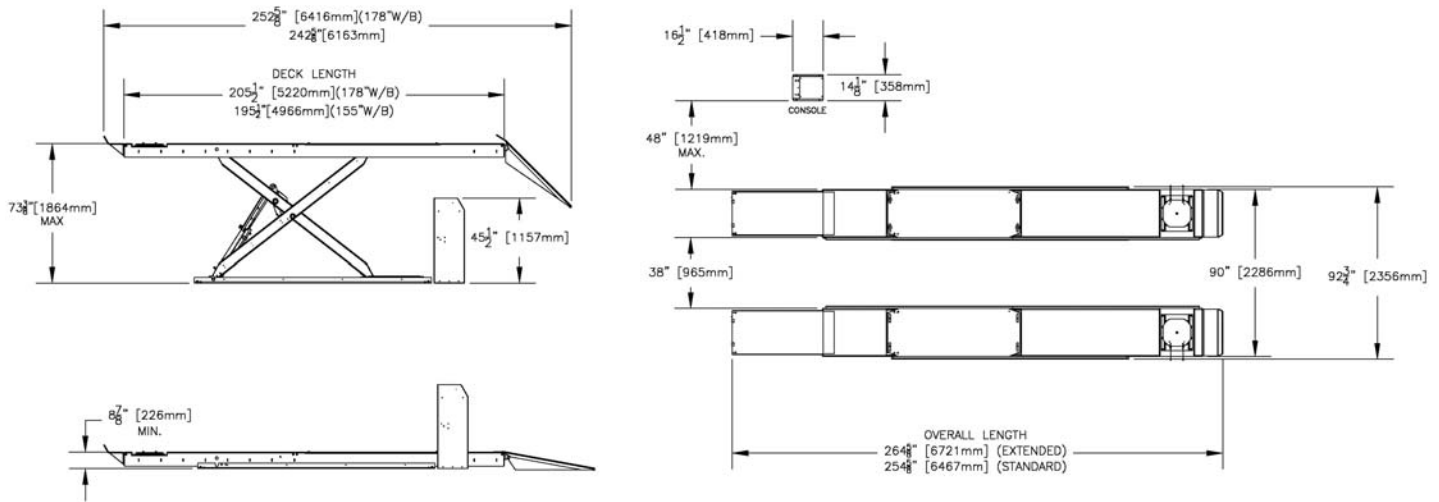

Models 4810605AF & 4810605AFX



In-rack air kit for rolling jacks and air tools.



Optional stainless steel turnplates slide on a UHMW layer preventing deck scratching.



8-position adjustable work step on each side for easy access to underhood and steering wheel adjustments.



Large twin interlocking serriform mechanical safety racks with 18 level and locked positions.

## Snap-on Equipment

Snap-on Equipment / 309 Exchange Avenue / Conway, Arkansas 72032 U.S.A.  
 Fax: 501-450-2085 / Toll Free: 1-800-362-4618 / Canada: 1-800-362-4608  
 www.SnaponEquipment.com / www.JohnBean.com  
 International: 501-450-1568