



14K Surface-Mount  
4814605LL

*Alignment Productivity In A Whole New Light*

**Locked & Lighted**  
Scissor Alignment Lifts

**JohnBean™**

### Shining A Light On Alignment Productivity

The John Bean Locked and Lighted Scissor Alignment Lifts represent the industries first certified lift with a light system in the market. Alignment inspection and adjustment areas are properly illuminated, making it easier for the technician to do their job. Scissor lifts also use less space. Five scissor lifts fit into the same operating space as four 4-post lifts!

#### All John Bean 10K and 14K Locked and Lighted Scissor Alignment Lifts Have:

- Triple safety systems with air-actuated mechanical lock release
- Twin interlocking mechanical safeties with 18 level and locked positions
- Large, 72", flush-mount, full-floating rear slip plates that are virtually maintenance free
- Open access front-to-rear between runways
- Simultaneously, pneumatically-locked turntables and rear slip plates
- A low-profile design with 50" approach ramps
- Integrated air kit for connecting Roller Jacks & air tools
- Met current ANSI/ALI ALCTV-2006 standards
- Optimally-positioned lighting for increased visibility



14K Surface-Mount  
4814605LL

### A Step Ahead of the Competition

- John Bean lift accessories are certified to the current ANSI/ALI standard.
- Lighting kit is standard with lift.
- Lights positioned so they will not cause shadows from equipment or blind the technician.
- LED lights consume less power and have a high lumen output while providing a crisp, clean white light – unlike competitor's fluorescent tube-style lights which produce a yellow tint.
- LED lights are safer & more durable than fluorescents.
- A certified lift requires certified accessories. Installation of Non-certified accessories voids lift certification!



# The Right Lifts For The Right Jobs



10K Surface-Mount  
4810605LL



14K Surface-Mount  
4814605LL

## 10K Scissor

- 10,000 lb. lifting capacity
- Proportionally-controlled, hydraulically-synchronized lifting systems with 2 powerful heavy-duty lifting cylinders to maintain level from floor to 72" of lifting height
- Low-profile stance of 9" allows for a gentle drive-on approach for low-profile vehicles
- Compact, enclosed console protects core components from the shop environment
- Full-length base frame accommodates fast installation and increases structural integrity

## 14K Scissor

- 14,000 lb. lifting capacity
- Advanced lifting system has 4 powerful cylinders that maintain a level position at any point from the floor up to 72" of lifting height
- Low-profile stance of 10" allows for a gentle drive-on approach for low-profile vehicles
- Compact, enclosed console protects core components from the shop environment
- Full-length base frame accommodates fast installation and increases structural integrity

## Flush-Mount Models Available!

Zero Drive-Over Clearance!



14K Flush-Mount  
4814605LLFM

10K Flush-Mount  
4810605LLFM  
4810605XLLFM

## Standard Accessories

### Roller Jacks

John Bean's complete line of air/hydraulic Roller Jacks are versatile, durable and optimize the profitability of any lift. A low-profile design eliminates the need to swing away when the lift is lowered. A high lifting height enables more access for under-car repairs. Interchangeable adapters make lifting fast for brake work and tire service on passenger cars, light trucks & vans. Easy to maintain & built to last!



- EELR503A (Low-profile 5,000 lb. lifting capacity, for 10K Scissor Lifts)
- JBC217 (7,000 lb. lifting capacity, for 14K Scissor Lifts)

# Features

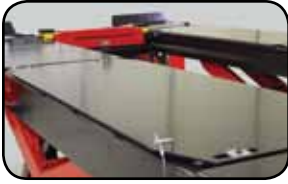

## Slip Plates

Durable 72" slip plates glide on over-sized bearings, providing the range of motion needed to apply rear alignment corrections. Slip plates are maintenance-free due to strategically-positioned openings in the runway, which quickly disperse water and dirt - allowing for reliable performance every time!



## Integrated Air Kit

Center runway mounted outlet allows rear inlet to roller jacks allowing easy, clear access to operator controls.



## Smooth Lifting

Ultra-High Molecular Weight slide blocks allow for smooth and uniform lifting.



## Triple Safety System

Includes large twin-interlocking air-actuated mechanical safety locks featuring 18 level and locked positions, velocity fuses, & pressure-sensing flow control valves.

## Widest Runways

Long and wide runways allow for alignment service on a wide range of vehicle widths and wheelbases.

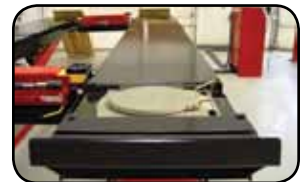

## Standard Hands-Free True Task™ Lighting System

- Optimized positioning of rear lights illuminate the widest range of vehicle track widths.
- Rear tilting light bars increase the viewing angle and direct light where it's needed.
- Front lights are mounted into the base of the turntable and accommodate wider vehicles.
- Lights are automatically activated/deactivated at a predetermined height.
- Crisp, clean white light reduces eye strain and fatigue on your technicians.
- Light kits are certified accessory for lifts listed.



## Standard Locking Components

- Turntables and Slip Plates that can be pneumatically locked from the operator console.
- Increases productivity by locking turntables and slip plates simultaneously.
- Ensures the proper amount of movement in all directions is always available to perform alignments.



## 14K SCISSOR LINE DRAWINGS (SURFACE-MOUNT)

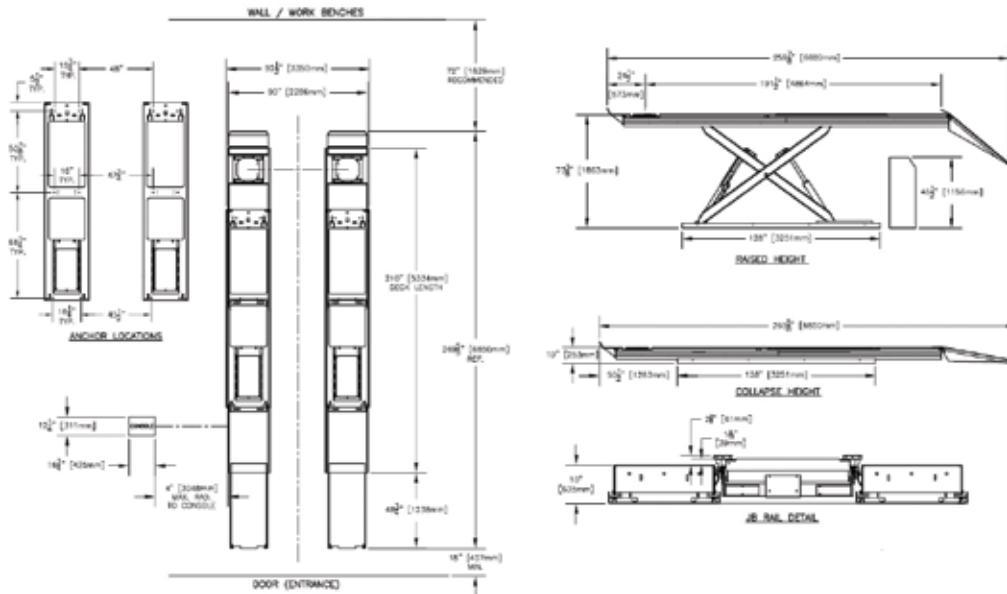

This diagram is for promotion illustration purposes only, and should not be used as installation instructions. Contact your local Equipment Sales Specialist if further information is needed.

## 10K SCISSOR LINE DRAWINGS (SURFACE-MOUNT)

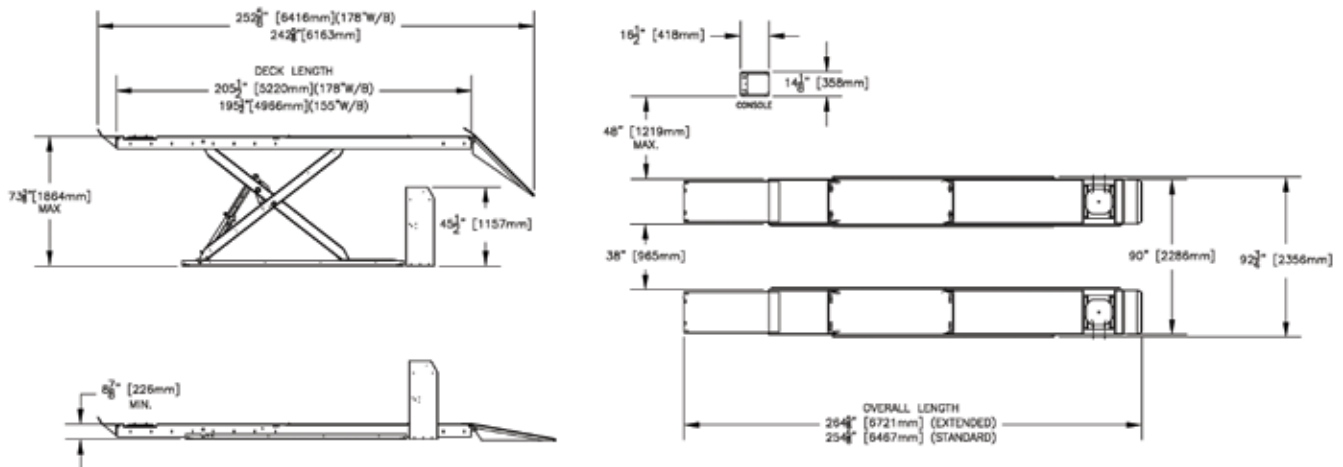

**Models 4810605LL**

This diagram is for promotion illustration purposes only, and should not be used as installation instructions. Contact your local Equipment Sales Specialist if further information is needed.

## 14K SCISSOR LINE DRAWINGS (FLUSH-MOUNT)

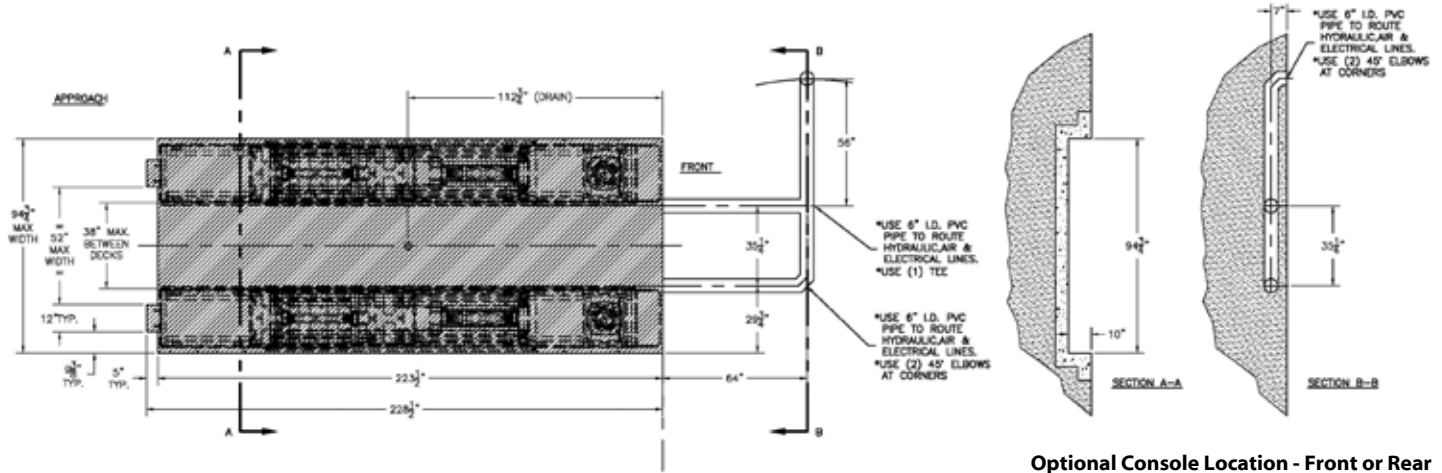

Optional Console Location - Front or Rear

This diagram is for promotion illustration purposes only, and should not be used as installation instructions. Contact your local Equipment Sales Specialist if further information is needed. Layout subject to change without notice, request detailed layout drawing for pit construction.

For up-to-date line drawings and more information about John Bean Locked & Lighted Scissor Lifts, contact a Local Sales Representative.

## SPECIFICATIONS

	4810605LL 4810605LLFM*	4810605XLL 4810605XLLFM*	4814605LL 4814605LLFM*
<b>Maximum Capacity</b>	10,000 lbs.	10,000 lbs.	14,000 lbs.
<b>Overall Width</b>	92.5"	92.5"	92.5"
<b>Width Between Runways</b>	38"	38"	38"
<b>Overall Length (Surface-Mount)</b>	255.375"/223.625"*	265.375"/234.625"*	270"/238.625"*
<b>4-Wheel Alignment Wheelbase (Min./Max.)</b>	88"/155"	88"/155"	88"/155"
<b>2-Wheel Alignment Wheelbase</b>	165"	175"	182"
<b>Service Wheelbase</b>	179"	189"	196"
<b>Runway Surface Length†</b>	195.5"	205.5"	210"
<b>Runway Surface Width</b>	26"	26"	26"
<b>Maximum Raised Height</b>	72"/63"*	72"/63"*	72"/62"*
<b>Minimum Lowered Height</b>	9"/0"*	9"/0"*	9"/0"*
<b>Operator Console Dimensions (DxWxH)</b>	16.5" x 14.125" x 45.75"	16.5" x 14.125" x 45.75"	16.5" x 14.125" x 45.75"
<b>Lifting Time (Fully loaded)</b>	65 seconds	65 seconds	65 seconds
<b>Air Supply Requirements</b>	90 - 120 PSI	90 - 120 PSI	90 - 120 PSI
<b>Power Requirements (Standard)</b>	230V, 1Ph, 60Hz	230V, 1Ph, 60Hz	230V, 1Ph, 60Hz
<b>Shipping Weight‡</b>	5,522 lbs.	5,622 lbs.	5,863 lbs.

† Does not include front wheel stop.

\* Includes Lights, Locks and Roller Jacks.

\*Flush Mount Models

Snap-on Equipment / 309 Exchange Avenue / Conway, Arkansas 72032 U.S.A.  
Fax: 501-450-2085 / Toll Free: 1-800-362-4618 / International: 501-505-2739  
www.snaponequipment.com/johnbean

John Bean Canada / 6500 Millcreek Drive / Mississauga, Ontario L5N 2W6  
Customer Service: 1-800-362-4608 / Fax: 905-826-7800  
www.johnbean.ca

