

SPECIFICATIONS

	4810605AF 4810605AFM*	4810605AFX 4810605AFMX*	4814605AF 4814605AFM*
Maximum Capacity	10,000 lbs.	10,000 lbs.	14,000 lbs.
Overall Width	92.5"	92.5"	92.5"
Width Between Runways	38"	38"	38"
Overall Length (Surface-Mount)	255.375"	265.375"	270"
Overall Length (Flush-Mount)	223.625"	234.625"	238.625"
4-Wheel Alignment Wheelbase (Min./Max.)	88"/155"	88"/155"	88"/155"
2-Wheel Alignment Wheelbase	165"	175"	182"
Service Wheelbase	179"	189"	196"
Runway Surface Length[†]	195.5"	205.5"	210"
Runway Surface Width	26"	26"	26"
Maximum Raised Height	72"/63"*	72"/63"*	72"/62"*
Minimum Lowered Height	9"/0"*	9"/0"*	10"/0"*
Operator Console Dimensions (DxWxH)	16.5" x 14.125" x 45.75"	16.5" x 14.125" x 45.75"	16.5" x 14.125" x 45.75"
Lifting Time (Fully loaded)	75 seconds	75 seconds	75 seconds
Lowering Time	65 seconds	65 seconds	45 seconds
Air Supply Requirements	90 - 120 PSI	90 - 120 PSI	90 - 120 PSI
Power Requirements (Standard)	230V, 1Ph, 60Hz	230V, 1Ph, 60Hz	230V, 1Ph, 60Hz
Shipping Weight[‡]	5,452 lbs.	5,552 lbs.	5,793 lbs.

[†] Does not include front wheel stop.

[‡] Includes Roller Jacks.

*Flush Mount Models

10K SCISSOR LINE DRAWINGS (SURFACE-MOUNT)

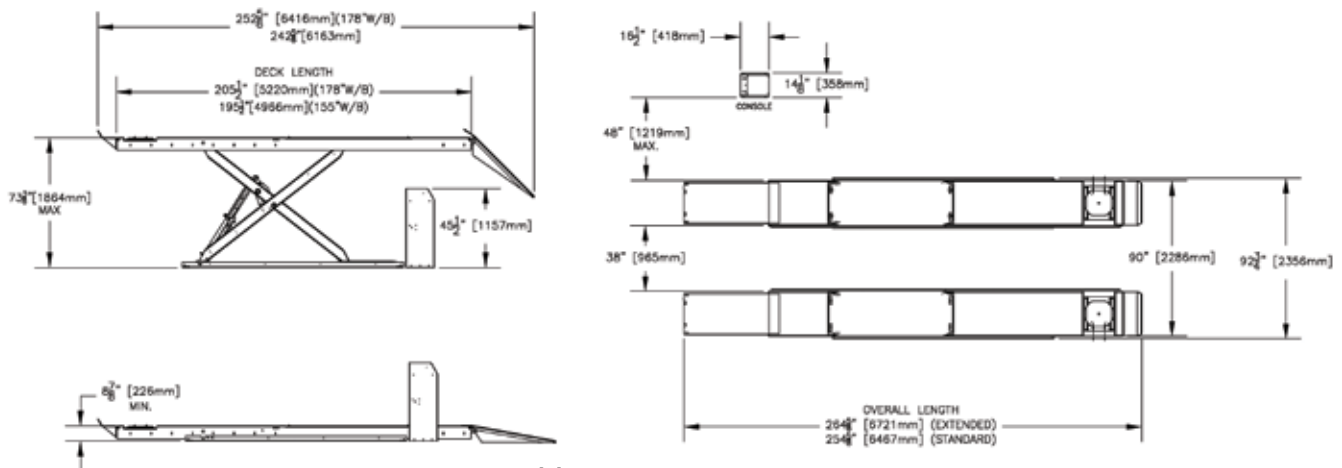

Models 4810605AF & 4810605AFX

This diagram is for promotion illustration purposes only, and should not be used as installation instructions. Contact your local Equipment Sales Specialist if further information is needed.

The World's Largest Wheel Service Equipment Company
Snap-on EQUIPMENT

Snap-on Equipment / 309 Exchange Avenue / Conway, Arkansas 72032 U.S.A.
 Fax: 501-450-2085 / Toll Free: 1-800-362-4618 / International: 501-505-2739
www.snaponequipment.com/johnbean

John Bean Canada / 6500 Millcreek Drive / Mississauga, Ontario L5N 2W6
 Customer Service: 1-800-362-4608 / Fax: 905-826-7800
www.johnbean.ca

